

FEATURES:

- Compliant with Intel DB800 spec
- Eight differential clock pairs at 0.7V
- 50ps skew
- 50ps cycle-to-cycle jitter
- Programmable Bandwidth
- PLL bypass configurable
- Divide by 2 programmable
- Available in SSOP and TSSOP packages

DESCRIPTION:

The CV141 differential buffer is compliant with Intel DB800 specifications. It is intended to distribute the SRC (serial reference clock) as a companion chip to the main clock of the CK409, CK410/CK410M, CK410B, etc. PLL is off in bypass mode and has no clock detect.

FUNCTIONAL BLOCK DIAGRAM

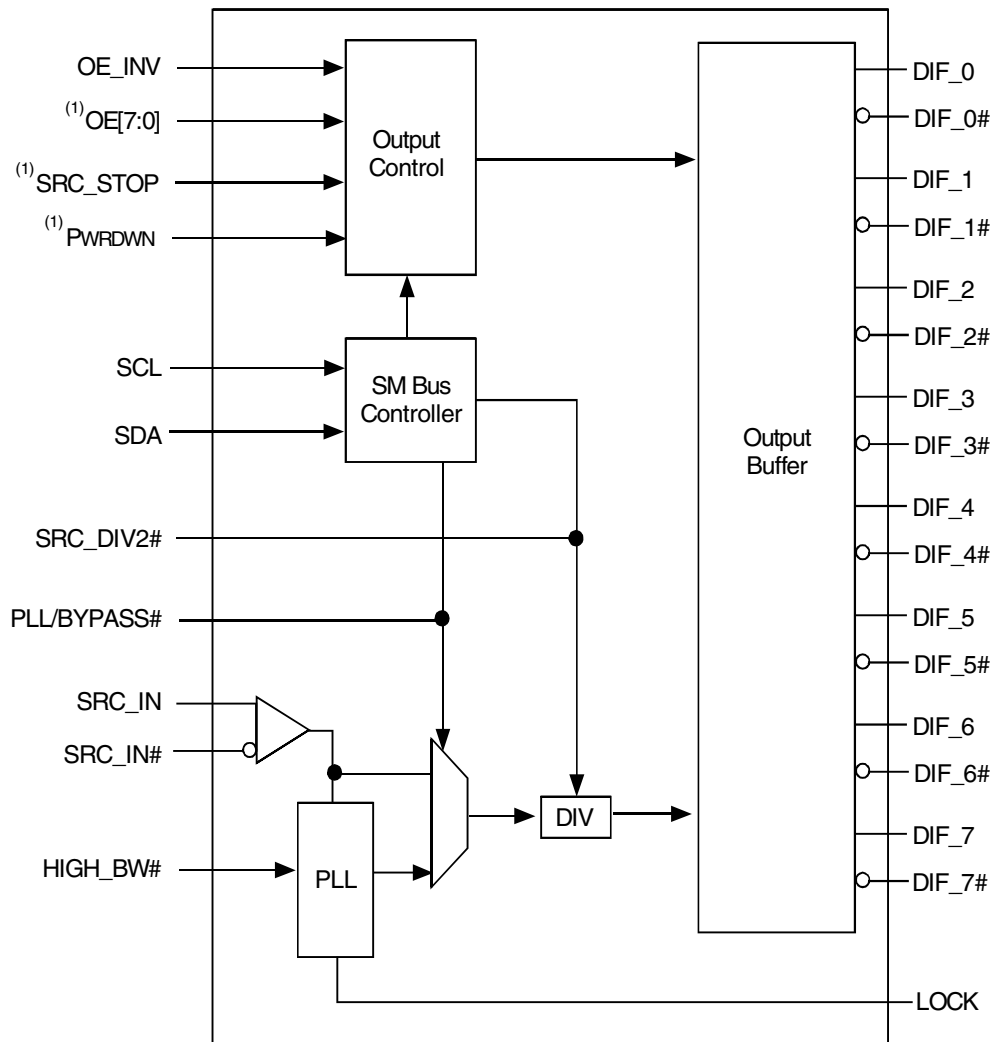

NOTE:

1. See OE\_INV table for active HIGH or active LOW.

## PIN CONFIGURATION

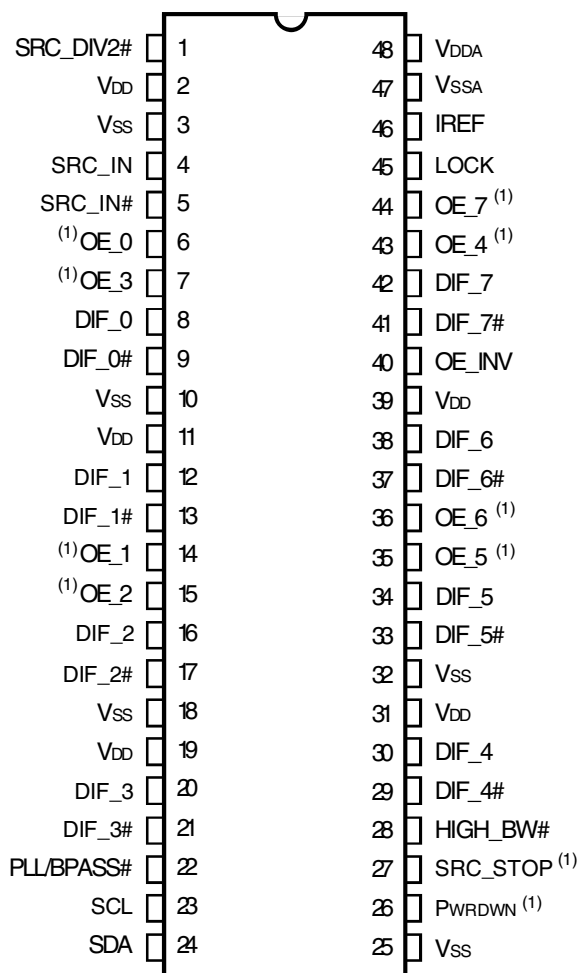

**NOTE:**  
1. See OE\_INV table for active HIGH or active LOW.

### SSOP/ TSSOP TOP VIEW

## OE FUNCTIONALITY [OE\_INV = 0]

OE_[7:0] - Pin	OE_[7:0] - SMBus bit	DIF_[7:0]	DIFF_[7:0]#
1	1	Normal	Normal
1	0	Tristate	Tristate
0	1	Tristate	Tristate
0	0	Tristate	Tristate

## ABSOLUTE MAXIMUM RATINGS<sup>(1)</sup>

Symbol	Description	Min	Max	Unit
VDDA	3.3V Core Supply Voltage		4.6	V
VDDIN	3.3V Logic Input Supply Voltage	GND - 0.5	4.6	V
TSTG	Storage Temperature	-65	+150	°C
TAMBIENT	Ambient Operating Temperature	0	+70	°C
TCASE	Case Temperature		+115	°C
ESD Prot	Input ESD Protection Human Body Model	2000		V

**NOTE:**

1. Stresses greater than those listed under ABSOLUTE MAXIMUM RATINGS may cause permanent damage to the device. This is a stress rating only and functional operation of the device at these or any other conditions above those indicated in the operational sections of this specification is not implied. Exposure to absolute maximum rating conditions for extended periods may affect reliability.

## OE\_INV

	OE_INV = 0	OE_INV = 1
OE_[7:0]	Active HIGH	Active LOW
PWRDWN	Active LOW	Active HIGH
SRC_STOP	Active LOW	Active HIGH

## HIGH\_BW# SELECTION

	HIGH_BW# = 0			HIGH_BW# = 1			Unit
	Min.	Typ.	Max.	Min.	Typ.	Max.	
PLL BW	2	3	4	0.7	1	1.4	MHz
PLL Peaking	—	1	3	—	1	3	dB

## OE FUNCTIONALITY [OE\_INV = 1]

OE_[7:0] - Pin	OE_[7:0] - SMBus bit	DIF_[7:0]	DIFF_[7:0]#
1	1	Tristate	Tristate
1	0	Tristate	Tristate
0	1	Normal	Normal
0	0	Tristate	Tristate

## PIN DESCRIPTION

Pin Name	Type	Pin #	Description
SRC_IN, SRC_IN#	IN, DIF	4,5	0.7V differential SRC input
DIF_[7:0], DIF_ [7:0]#	OUT, DIF	8, 9, 12, 13, 16, 17, 20, 21, 29, 30, 33, 34, 37, 38, 41, 42	0.7V differential clock output
OE[7:0]	IN	6, 7, 14, 15, 35, 36, 43, 44	3.3VLVTTL input for enabling differential outputs (see OE_INV table)
PWRDWN	IN	26	3.3V LVTTTL for power down (see OE_INV table)
IREF	IN	46	Reference current for differential output
LOCK	OUT	45	HIGH, locked
PLL/Bypass#	IN	22	1 = PLL mode, 0 = bypass, PLL OFF
HIGH_BW#	IN	28	0 = HIGH BW, 1 = LOW BW (see HIGH_BW# Selection table)
SRC_DIV2#	IN	1	LOW = divide by 2 mode
SRC_STOP	IN	27	SRC stop (see OE_INV table)
SCL	IN	23	SMBus clock
SDA	I/O, Open Collector	24	SMBus data
OE_INV	IN	40	(see OE_INV table)

## INDEX BLOCK WRITE PROTOCOL

Bit	# of bits	From	Description
1	1	Master	Start
2-9	8	Master	DCh
10	1	Slave	Ack (Acknowledge)
11-18	8	Master	Register offset byte (starting byte)
19	1	Slave	Ack (Acknowledge)
20-27	8	Master	Byte count, N (0 is not valid)
28	1	Slave	Ack (Acknowledge)
29-36	8	Master	first data byte (Offset data byte)
37	1	Slave	Ack (Acknowledge)
38-45	8	Master	2nd data byte
46	1	Slave	Ack (Acknowledge)
			:
		Master	Nth data byte
		Slave	Acknowledge
		Master	Stop

## INDEX BYTE WRITE

Setting bit[11:18] = starting address, bit[20:27] = 01h.

## INDEX BLOCK READ PROTOCOL

Master can stop reading any time by issuing the stop bit without waiting until Nth byte (byte count bit30-37).

Bit	# of bits	From	Description
1	1	Master	Start
2-9	8	Master	DCh
10	1	Slave	Ack (Acknowledge)
11-18	8	Master	Register offset byte (starting byte)
19	1	Slave	Ack (Acknowledge)
20	1	Master	Repeated Start
21-28	8	Master	DDh
29	1	Slave	Ack (Acknowledge)
30-37	8	Slave	Byte count, N (block read back of N bytes), power on is 8
38	1	Master	Ack (Acknowledge)
39-46	8	Slave	first data byte (Offset data byte)
47	1	Master	Ack (Acknowledge)
48-55	8	Slave	2nd data byte
			Ack (Acknowledge)
			:
		Master	Ack (Acknowledge)
		Slave	Nth data byte
			Not acknowledge
		Master	Stop

## INDEX BYTE READ

Setting bit[11:18] = starting address. After reading back the first data byte, master issues Stop bit.

## CONTROL REGISTERS

### BYTE 0

Bit	Output(s) Affected	Description/Function	0	1	Type	Power On
7	PowerDown drive mode		Driven	Tri-state	RW	0
6	SRC_STOP# drive mode		Driven	Tri-state	RW	0
5	Reserved				RW	0
4	Reserved				RW	0
3	Reserved				RW	0
2	High_BW#	Logically AND with HW pin	High band width	Low band width	RW	1
1	PLL/Bypass#	Logically AND with HW pin	Bypass	PLL mode	RW	1
0	SRC_DIV2#	Logically AND with HW pin	Divided by 2	Normal	RW	1

### BYTE 1

Bit	Output(s) Affected	Description/Function	0	1	Type	Power On
7	DIFF_7	Output Enable	Tristate	Enable	RW	1
6	DIFF_6	Output Enable	Tristate	Enable	RW	1
5	DIFF_5	Output Enable	Tristate	Enable	RW	1
4	DIFF_4	Output Enable	Tristate	Enable	RW	1
3	DIFF_3	Output Enable	Tristate	Enable	RW	1
2	DIFF_2	Output Enable	Tristate	Enable	RW	1
1	DIFF_1	Output Enable	Tristate	Enable	RW	1
0	DIFF_0	Output Enable	Tristate	Enable	RW	1

### BYTE 2

Bit	Output(s) Affected	Description/Function	0	1	Type	Power On
7	DIFF_7	Free Running with SRC_STOP#	Free	stopped	RW	0
6	DIFF_6	Free Running with SRC_STOP#	Free	stopped	RW	0
5	DIFF_5	Free Running with SRC_STOP#	Free	stopped	RW	0
4	DIFF_4	Free Running with SRC_STOP#	Free	stopped	RW	0
3	DIFF_3	Free Running with SRC_STOP#	Free	stopped	RW	0
2	DIFF_2	Free Running with SRC_STOP#	Free	stopped	RW	0
1	DIFF_1	Free Running with SRC_STOP#	Free	stopped	RW	0
0	DIFF_0	Free Running with SRC_STOP#	Free	stopped	RW	0

### BYTE 3

Bit	Output(s) Affected	Description / Function	0	1	Type	Power On
7	Reserved				RW	
6	Reserved				RW	
5	Reserved				RW	
4	Reserved				RW	
3	Reserved				RW	
2	Reserved				RW	
1	Reserved				RW	
0	Reserved				RW	

BYTE 4

Bit	Output(s) Affected	Description / Function	0	1	Type	Power On
7		Revision ID			R	0
6		Revision ID			R	0
5		Revision ID			R	0
4		Revision ID			R	0
3		Vendor ID			R	0
2		Vendor ID			R	1
1		Vendor ID			R	0
0		Vendor ID			R	1

BYTE 62 = 10h

BYTE 63 = 14h

ELECTRICAL CHARACTERISTICS - INPUT / SUPPLY / COMMON OUTPUT PARAMETERS

Following Conditions Apply Unless Otherwise Specified:

Operating Condition:  $T_A = 0^{\circ}\text{C}$  to  $+70^{\circ}\text{C}$ , Supply Voltage:  $V_{DD} = 3.3\text{V} \pm 5\%$

Symbol	Parameter	Test Conditions	Min.	Typ.	Max.	Unit
$V_{IH}$	Input HIGH Voltage	$3.3\text{V} \pm 5\%$	2	—	$V_{DD} + 0.3$	V
$V_{IL}$	Input LOW Voltage	$3.3\text{V} \pm 5\%$	$V_{SS} - 0.3$	—	0.8	V
$I_{IH}$	Input HIGH Current	$V_{IN} = V_{DD}$	-5	—	5	$\mu\text{A}$
$I_{IL1}$	Input LOW Current	$V_{IN} = 0\text{V}$ , inputs with no pull-up resistors	-5	—	—	$\mu\text{A}$
$I_{IL2}$	Input LOW Current	$V_{IN} = 0\text{V}$ , inputs with pull-up resistors	-200	—	—	$\mu\text{A}$
$L_{PIN}$	Pin Inductance <sup>(2)</sup>		—	—	7	nH
$C_{IN}$	Input Capacitance <sup>(2)</sup>	Logic inputs	—	—	5	pF
$C_{OUT}$		Output pin capacitance	—	—	6	

## ELECTRICAL CHARACTERISTICS - DIF 0.7 CURRENT MODE DIFFERENTIAL PAIR

Following Conditions Apply Unless Otherwise Specified:

Operating Condition:  $T_A = 0^{\circ}\text{C}$  to  $+70^{\circ}\text{C}$ , Supply Voltage:  $V_{DD} = 3.3\text{V} \pm 5\%$ ;  $C_L = 2\text{pF}$

Symbol	Parameter <sup>(1)</sup>	Test Conditions	Min.	Typ.	Max.	Unit
V <sub>HIGH</sub>	Voltage HIGH		+150	—	—	mV
V <sub>LOW</sub>	Voltage LOW		—	—	-150	
V <sub>MAX</sub>	Max Input Voltage	Measurement on single-ended signal using absolute value	—	—	1150	mV
V <sub>MIN</sub>	Min Input Voltage		-300	—	—	
V <sub>CROSS(ABS)</sub>	Crossing Voltage (abs)		250	—	550	mV
t <sub>r</sub>	Rise Time	V <sub>OL</sub> = 0.175V, V <sub>OH</sub> = 0.525V	175	—	700	ps
t <sub>f</sub>	Fall Time	V <sub>OL</sub> = 0.175V, V <sub>OH</sub> = 0.525V	175	—	700	ps
d-t <sub>r</sub>	Rise Time Variation		—	—	125	ps
d-t <sub>f</sub>	Fall Time Variation		—	—	125	ps
dt <sub>3</sub>	Duty Cycle	Measurement from differential waveform	45	—	55	%
ts <sub>3</sub>	Output Pin-to-Pin Skew	V <sub>T</sub> = 50%	—	—	50	ps
t <sub>CYC-CYC</sub>	Jitter, Cycle to Cycle <sup>(2)</sup>	Measurement from differential waveform	—	—	50	ps

**NOTES:**

- Parameter is guaranteed by design, but not 100% production tested.
- Bypass mode, additive.

## SRC\_IN 0.7V AC TIMING CHARACTERISTICS

Symbol	Parameter <sup>(1)</sup>	Min.	Max.	Unit
Rising Edge Rate	Rising Edge Rate	0.6	4	V/ns
Falling Edge Rate	Falling Edge Rate	0.6	4	V/ns
V <sub>IH</sub>	Differential Input HIGH Voltage	+150	—	mV
V <sub>IL</sub>	Differential Input LOW Voltage	—	-150	mV
V <sub>CROSS</sub>	Absolute Crossing Point Voltages	250	550	mV
V <sub>MAX</sub>	Absolute Maximum Input Voltage	—	+1.15	V
V <sub>MIN</sub>	Absolute Minimum Input Voltage	-0.3	—	V
Duty Cycle	SRC_IN Duty Cycle	45	55	%

## DIF AC TIMING CHARACTERISTICS

### PLL Bandwidth and Peaking

Symbol	Parameter	Min	Typ	Max	Units
T <sub>PROP,PLL</sub>	SRC_IN to DIF Propagation Delay, PLL Mode <sup>(1)</sup>	-250	—	250	ps
T <sub>PROP,BYPASS</sub>	SRC_IN to DIF Propagation Delay, Bypass Mode <sup>(1)</sup>	2.5	—	4.5	ns
T <sub>SKEW</sub>	DIF_[7:0] Pin to Pin Skew <sup>(1)</sup>	—	—	250	ps
PLL bandwidth	HIGH_BW#=0 (high bandwidth) <sup>(1)</sup>	2	3	4	MHz
PLL bandwidth	HIGH_BW#=1 (low bandwidth) <sup>(1)</sup>	0.7	1	1.4	MHz
PLL Peaking	PLL Peaking <sup>(1,2)</sup>	—	1	3	dB
T <sub>CCJITTER</sub>	Cycle to Cycle Jitter <sup>(1)</sup>	—	—	50	pS
Duty cycle	PLL Mode <sup>(1)</sup>	45	—	55	%
Duty cycle	Bypass (assume input is 50%) <sup>(1)</sup>	40	—	60	%

#### NOTES:

1. This parameter is guaranteed by design, but not 100% production tested.
2. Measured at 3dB downpoint.

## OUTPUT CONTROL

Symbol	Parameter	Min	Typ	Max	Units
T <sub>DRIVE_PWRDWN</sub>	CLK driven from PD De_Assertion	—	—	300	μs
T <sub>ACTIVE_PWRDWN</sub>	CLK Toggling from PD De_Assertion	—	—	1	ms
T <sub>ACTIVE_OE</sub>	CLK toggling from OE_[7:0] Assertion	2	—	6	Clock Periods
T <sub>INACTIVE_OE</sub>	CLK Tri-stated from OE_[7:0] De_Assertion	2	—	6	Clock Periods

### PWRDWN (OE\_INV = 0)

The PWRDWN signal is a de-bounced signal in that its state must remain unchanged during two consecutive rising edges of DIF# to be recognized as a valid assertion or de-assertion.

PWRDWN	DIF	DIF#
1	Normal	Normal
0	Iref*2 or Float	Float

### SRC\_STOP (OE\_INV = 0)

The SRC\_STOP signal is a de-bounced signal in that its state must remain unchanged during two consecutive rising edges of DIF# to be recognized as a valid assertion or de-assertion.

SRC_STOP	DIF	DIF#
1	Normal	Normal
0	Iref*6 or Float	Float

### PWRDWN (OE\_INV = 1)

PWRDWN	DIF	DIF#
1	Iref*2 or Float	Float
0	Normal	Normal

### SRC\_STOP (OE\_INV = 1)

SRC_STOP	DIF	DIF#
1	Iref*6 or Float	Float
0	Normal	Normal

## SRC STOP FUNCTIONALITY

The SRC\_STOP signal is an input controlling DIF[7:0] and DIF[7:0] # outputs. This signal can be asserted asynchronously. SRC\_STOP is active high when OE\_INV = HIGH (see OE\_INV table).

### SRC\_STOP = DRIVEN, PWRDWN = DRIVEN

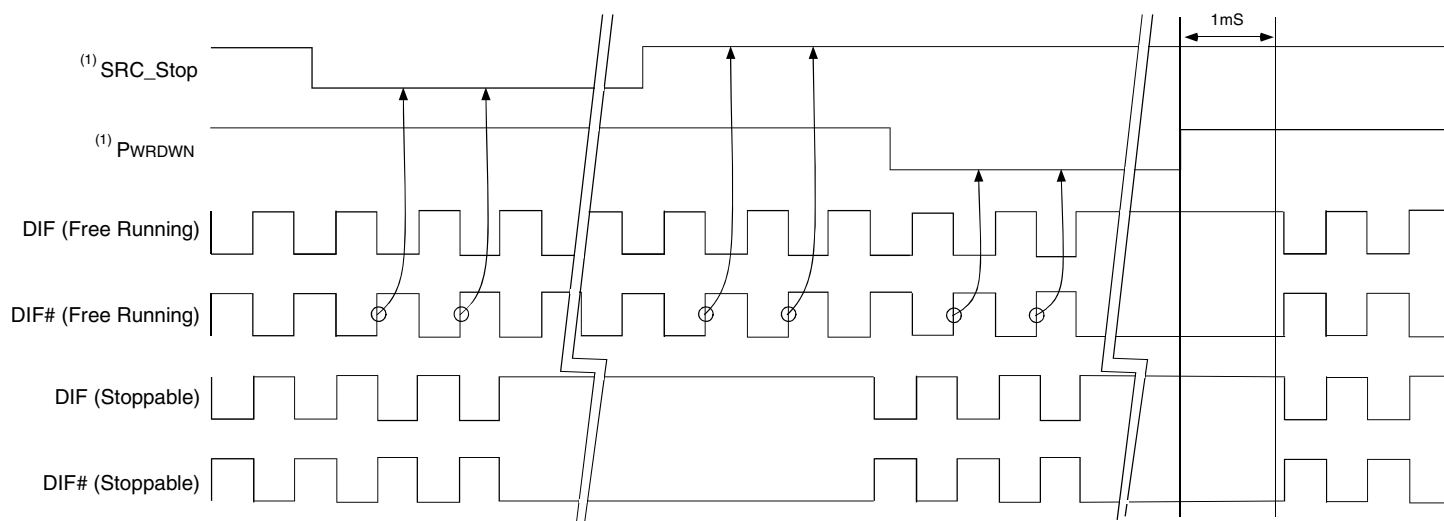

### SRC\_STOP = TRISTATE, PWRDWN = DRIVEN

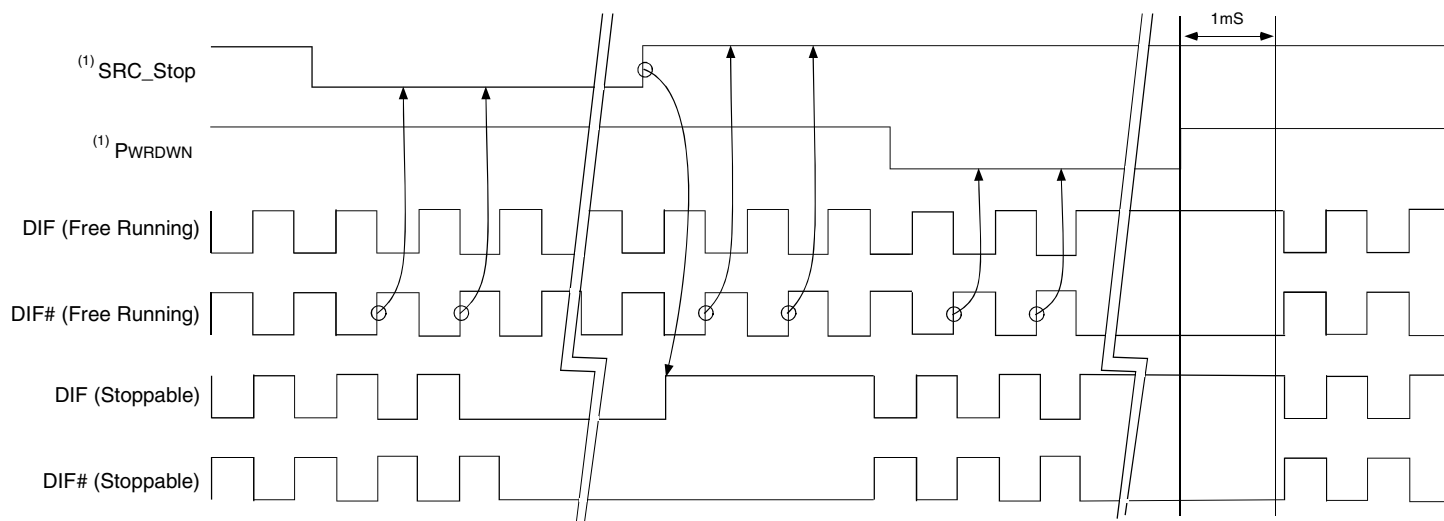

**NOTE:**

1. The polarity depends on OE\_INV.



SRC\_STOP = DRIVEN, PWRDWN = TRISTATE

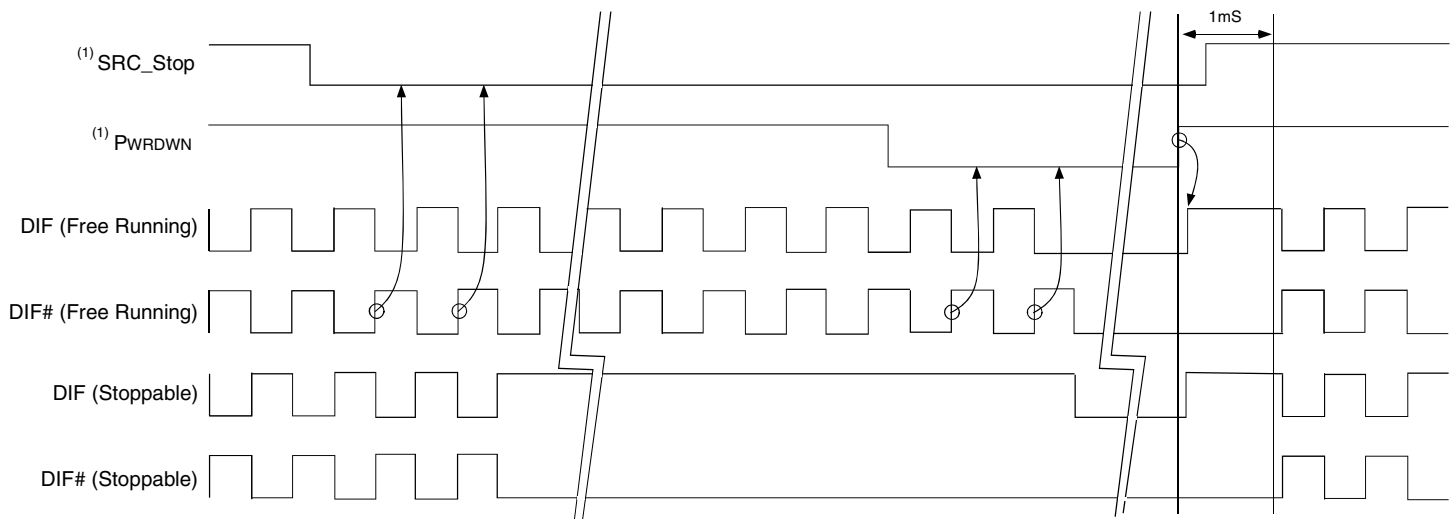

SRC\_STOP = TRISTATE, PWRDWN = TRISTATE

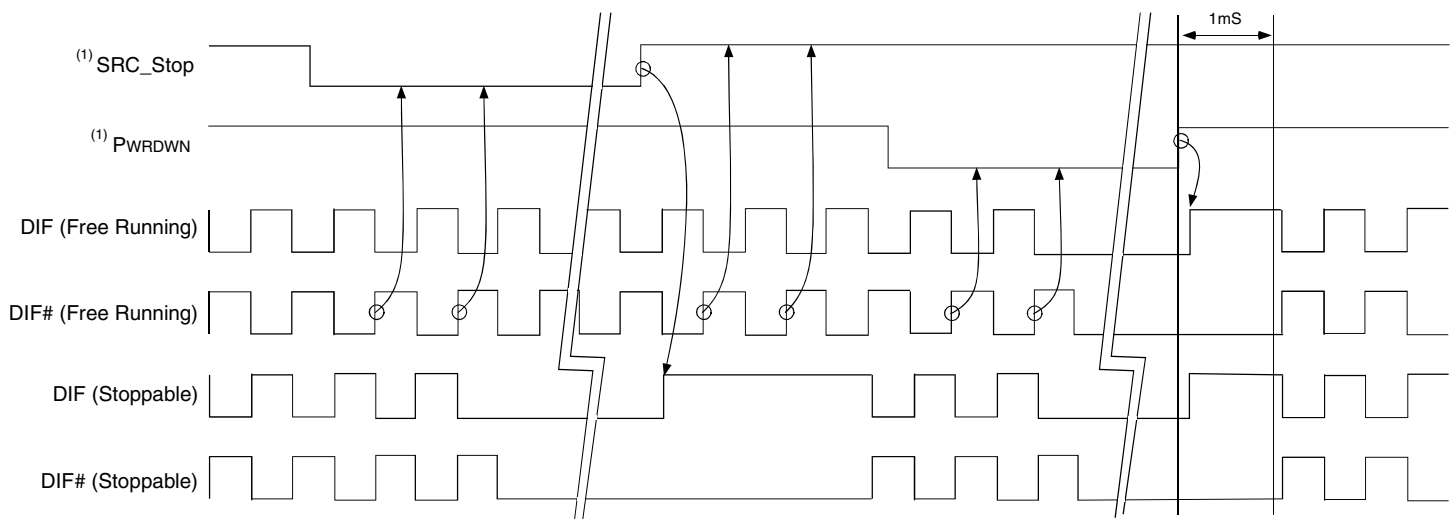

**NOTE:**  
1. The polarity depends on OE\_INV.

### ORDERING INFORMATION

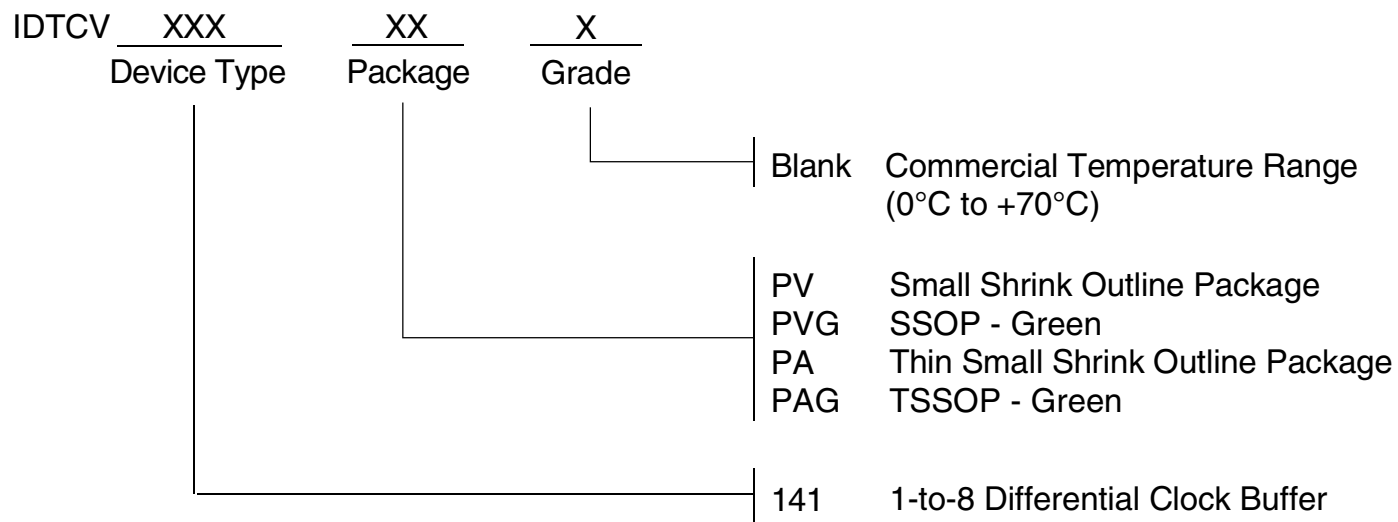

## IMPORTANT NOTICE AND DISCLAIMER

RENESAS ELECTRONICS CORPORATION AND ITS SUBSIDIARIES (“RENESAS”) PROVIDES TECHNICAL SPECIFICATIONS AND RELIABILITY DATA (INCLUDING DATASHEETS), DESIGN RESOURCES (INCLUDING REFERENCE DESIGNS), APPLICATION OR OTHER DESIGN ADVICE, WEB TOOLS, SAFETY INFORMATION, AND OTHER RESOURCES “AS IS” AND WITH ALL FAULTS, AND DISCLAIMS ALL WARRANTIES, EXPRESS OR IMPLIED, INCLUDING, WITHOUT LIMITATION, ANY IMPLIED WARRANTIES OF MERCHANTABILITY, FITNESS FOR A PARTICULAR PURPOSE, OR NON-INFRINGEMENT OF THIRD-PARTY INTELLECTUAL PROPERTY RIGHTS.

These resources are intended for developers who are designing with Renesas products. You are solely responsible for (1) selecting the appropriate products for your application, (2) designing, validating, and testing your application, and (3) ensuring your application meets applicable standards, and any other safety, security, or other requirements. These resources are subject to change without notice. Renesas grants you permission to use these resources only to develop an application that uses Renesas products. Other reproduction or use of these resources is strictly prohibited. No license is granted to any other Renesas intellectual property or to any third-party intellectual property. Renesas disclaims responsibility for, and you will fully indemnify Renesas and its representatives against, any claims, damages, costs, losses, or liabilities arising from your use of these resources. Renesas' products are provided only subject to Renesas' Terms and Conditions of Sale or other applicable terms agreed to in writing. No use of any Renesas resources expands or otherwise alters any applicable warranties or warranty disclaimers for these products.

(Disclaimer Rev.1.01)

### Corporate Headquarters

TOYOSU FORESIA, 3-2-24 Toyosu,  
Koto-ku, Tokyo 135-0061, Japan  
[www.renesas.com](http://www.renesas.com)

### Trademarks

Renesas and the Renesas logo are trademarks of Renesas Electronics Corporation. All trademarks and registered trademarks are the property of their respective owners.

### Contact Information

For further information on a product, technology, the most up-to-date version of a document, or your nearest sales office, please visit [www.renesas.com/contact-us/](http://www.renesas.com/contact-us/).