

FEATURES:

- Compliant with Intel CK505
- Power management control suitable for low power applications
- One high precision PLL for CPU/SRC/PCI, SSC and N programming
- One high precision PLL for SRC/PCI, SSC and N programming
- One high precision PLL for 96MHz/48MHz
- Push-pull IOs for differential outputs
- Support spread spectrum modulation, -0.5 down spread and others
- Support SMBus block read/write, index read/write
- Selectable output strength
- Smooth transition for N programming
- Available in SSOP and TSSOP packages

KEY SPECIFICATIONS:

- CPU/SRC CLK cycle to cycle jitter < 85ps
- PCI CLK cycle to cycle jitter < 500ps

DESCRIPTION:

IDTCV174C is a 56 pin clock device, incorporating Intel CK505 requirements for the Intel advance P4 processor. The CPU output buffer is designed to support up to 400MHz reference clock for the CPU. This chip has three PLLs inside for CPU, SRC/PCI and 48MHz/DOT96 IO clocks.

OUTPUTS:

- 2*0.7V differential CPU CLK pair
- 7*0.7V differential SRC CLK pair
- One CPU_ITP/SRC differential clock pair
- One SRC0/DOT96 differential clock pair
- 6*PCI, 33.3MHz
- 1*48MHz
- 1*REF
- 1*SATA

FUNCTIONAL BLOCK DIAGRAM

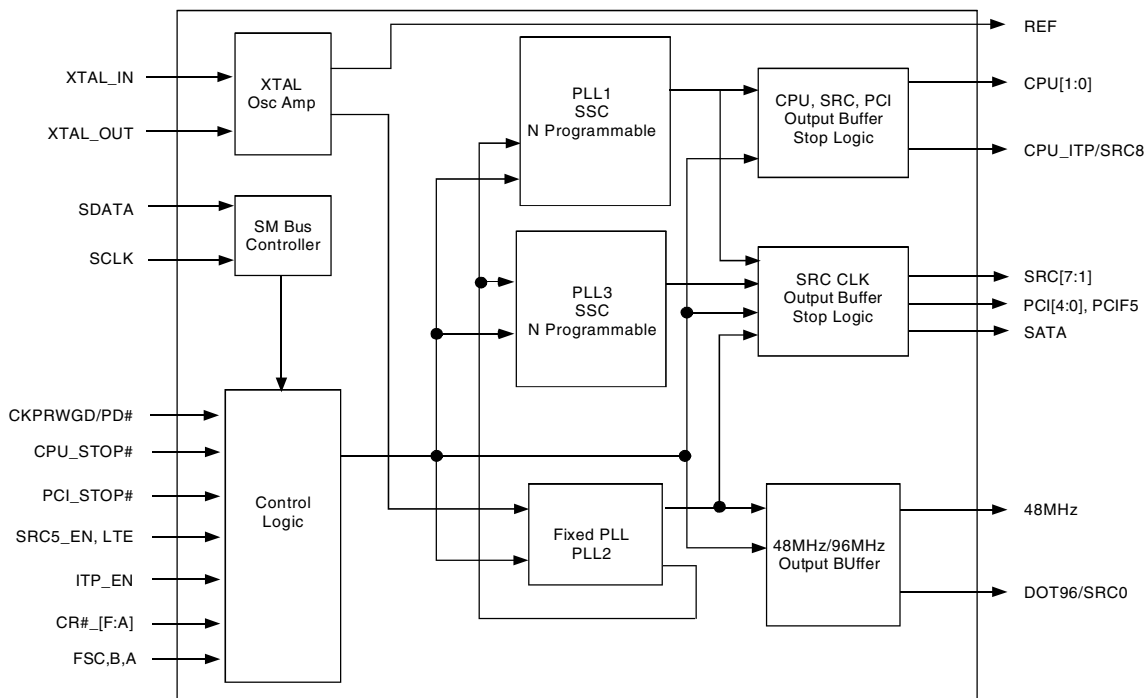

The IDT logo is a registered trademark of Integrated Device Technology, Inc.

COMMERCIAL TEMPERATURE RANGE

MAY 2006

PIN CONFIGURATION

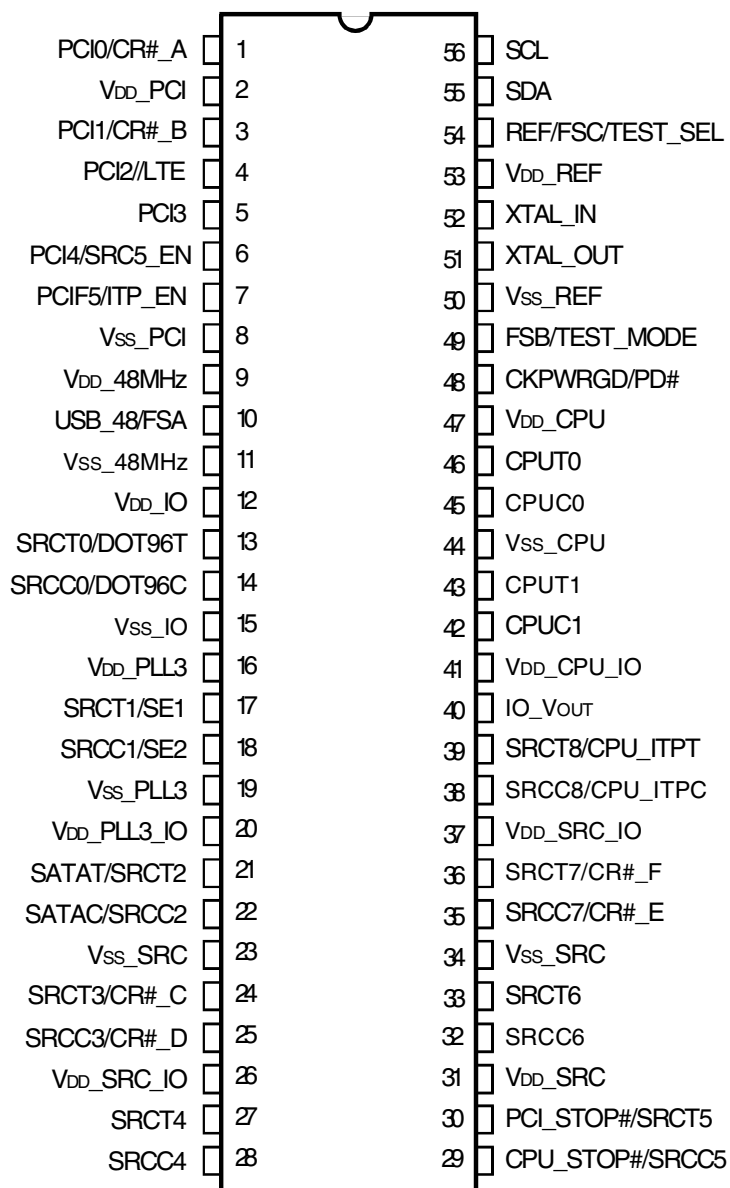

TSSOP
TOP VIEW

PIN DESCRIPTION

Pin #	Name	Type	Description
1	PCI0/CR#_A	I/O	33.33MHz/SRC0, 2 Differential clock output enable, control SRC0 and SRC2, 0 = enable. Mode is selected by SMBus control register. Default is PCI clock mode
2	V _{DD_PCI}	PWR	3.3V
3	PCI1/CR#_B	I/O	33.33MHz/SRC1, 2 Differential clock output enable, control SRC1 and SRC4, 0 = enable. Mode is selected by SMBus control register. Default is PCI clock mode
4	PCI2/LTE	I/O	33.33MHz. High = overlocking disabled. Power-on latch.
5	PCI3	OUT	33.33MHz
6	PCI4/SRC5_EN	I/O	33.33MHz. Pin 29, 30 mode selection. Power on latch, high = SRC5, low = CPU and PCI Stop#
7	PCIF5/ITP_EN	I/O	33.33MHz. Pin 38, 39 mode selection. Power on latch, high = CPU_ITP, low = SRC8
8	V _{SS_PCI}	GND	GND
9	V _{DD_48}	PWR	3.3V
10	USB 48/FS_A	I/O	48MHz/ Frequency select, power on latch
11	V _{SS_48}	GND	GND
12	V _{DD_IO}	PWR	0.8V
13	SRCT0/DOT96T	OUT	Differential output clock. SRC or DOT96. Mode selected by SMBus control register, default is SRC0
14	SRCC0/DOT96C	OUT	Differential output clock. SRC or DOT96. Mode selected by SMBus control register, default is SRC0
15	V _{SS_IO}	GND	GND
16	V _{DD_PLL3}	PWR	3.3V
17	SRCT1/SE1	OUT	Differential or single end clock output. Mode selected by SMBus control register. Default is SRC1.
18	SRCC1/SE2	OUT	Differential or single end clock output. Mode selected by SMBus control register. Default is SRC1
19	V _{SS_PLL3}	GND	GND
20	V _{DD_PLL3_IO}	PWR	0.8V
21	SRCT2/SATAT	OUT	Differential output clock
22	SRCC2/SATAC	OUT	Differential output clock
23	V _{SS_SRC}	GND	GND
24	SRCT3/CR#_C	I/O	SRC clock/ SRC differential clock output enable, control SRC0 and SRC2, 0 = enable. Mode selected by SMBus control register. Default is SRC3.
25	SRCC3/CR#_D	I/O	SRC clock/ SRC differential clock output enable, control SRC1 and SRC4, 0 = enable. Mode selected by SMBus control register. Default is SRC3..
26	V _{DD_SRC_IO}	PWR	0.8V
27	SRCT4	OUT	Differential output clock
28	SRCC4	OUT	Differential output clock
29	CPU_Stop#/SRCC5	I/O	CPU stop, low = stop/ SRC clock. Mode selected by pin6, SRC5_EN.
30	PCI_Stop#/SRCT5	I/O	PCI stop, low = stop/ SRC clock. Mode selected by pin6, SRC5_EN.
31	V _{DD_SRC}	PWR	3.3V
32	SRCC6	OUT	Differential output clock
33	SRCT6	OUT	Differential output clock
34	V _{SS_SRC}	GND	GND
35	SRCC7/CR#_E	I/O	SRC clock/ SRC differential clock output enable, control SRC6, 0 = enable. Mode selected by SMBus control register. Default is SRC7.
36	SRCT7/CR#_F	I/O	SRC clock/ SRC differential clock output enable, control SRC8, 0 = enable. Mode selected by SMBus control register. Default is SRC7.
37	V _{DD_SRC_IO}	PWR	0.8V
38	SRCC8/CPU_ ITPC	OUT	SRC clock/CPU clock. Mode selected by pin7.
39	SRCT8/CPU_ ITPT	OUT	SRC clock/CPU clock. Mode selected by pin7.
40	IO_V _{OUT}	OUT	V _{IO} adjustment

PIN DESCRIPTION, CONTINUED

Pin #	Name	Type	Description
41	V _{DD_CPU_IO}	PWR	0.8V
42	CPUC1	OUT	Differential output clock
43	CPUT1	OUT	Differential output clock
44	V _{SS_CPU}	GND	GND
45	CPUC0	OUT	Differential output clock
46	CPUT0	OUT	Differential output clock
47	V _{DD_CPU}	PWR	3.3V
48	CKPWRGD/PD#	IN	CKPWRGD power good, active LOW, used to latch FSA,B,C, ITP_EN, TME, and SRC5_EN, active HIGH. After, becomes power down, LOW active.
49	FS_B/TestMode	IN	Frequency Select at CKPWRGD assertion. Test Mode selection, see TEST_MODE selection table
50	V _{SS_REF}	GND	GND
51	XTAL_OUT	OUT	XTAL out
52	XTAL_IN	IN	XTAL in
53	V _{DD_REF}	PWR	3.3V
54	REF/FS_C/TestSel	I/O	14.318MHz. Frequency Select at CKPWRGD assertion. Selects test mode if pulled above 2V at CKPWRGD assertion.
55	SDA	I/O	SMBus clock
56	SCL	IN	SMBus data

TEST MODE SELECTION⁽¹⁾

If TEST_SEL sampled above 2V at CKPWRGD active LOW

Test_Mode	CPU	SRC	PCI/F	REF	DOT_96/DOT_SSC	USB
1	REF/N	REF/N	REF/N	REF	REF/N	REF/N
0	Hi-Z	Hi-Z	Hi-Z	Hi-Z	Hi-Z	Hi-Z

NOTE:

1. Once test clock operation has been invoked, TEST_MODE pin will select between the Hi-Z and REF/N, with V_{IH_FS} and V_{IL_FS} thresholds.

FREQUENCY SELECTION

FSC, B, A	CPU	SRC[7:0]	PCI	USB	DOT	REF
101	100	100	33.3	48	96	14.318
001	133	100	33.3	48	96	14.318
011	166	100	33.3	48	96	14.318
010	200	100	33.3	48	96	14.318
000	266	100	33.3	48	96	14.318
100	333	100	33.3	48	96	14.318
110	400	100	33.3	48	96	14.318
111	Reserve	100	33.3	48	96	14.318

ABSOLUTE MAXIMUM RATINGS⁽¹⁾

Symbol	Description	Min	Max	Unit
V _{DDA}	3.3V Core Supply Voltage		4.6	V
V _{DD}	3.3V Logic Input Supply Voltage	GND - 0.5	4.6	V
T _{STG}	Storage Temperature	-65	+150	°C
T _{AMBIENT}	Ambient Operating Temperature	0	+70	°C
T _{CASE}	Case Temperature		+115	°C
ESD Prot	Input ESD Protection Human Body Model	2000		V

NOTE:

- Stresses greater than those listed under ABSOLUTE MAXIMUM RATINGS may cause permanent damage to the device. This is a stress rating only and functional operation of the device at these or any other conditions above those indicated in the operational sections of this specification is not implied. Exposure to absolute maximum rating conditions for extended periods may affect reliability.

RESOLUTION

	N Resolution (MHz)	%	N =
CPU = 100MHz	0.500000	0.5%	200
CPU = 133MHz	0.666667	0.5%	200
CPU = 166MHz	0.666667	0.4%	250
CPU = 200MHz	1.000000	0.5%	200
CPU = 266MHz	1.333333	0.5%	200
CPU = 333MHz	1.333333	0.4%	250
CPU = 400MHz	2.000000	0.5%	200
SRC = 100MHz	0.500000	0.5%	200

SM PROTOCOL

INDEX BLOCK WRITE PROTOCOL

Bit	# of bits	From	Description
1	1	Master	Start
2-9	8	Master	D2h
10	1	Slave	Ack (Acknowledge)
11-18	8	Master	Register offset byte (starting byte)
19	1	Slave	Ack (Acknowledge)
20-27	8	Master	Byte count, N (0 is not valid)
28	1	Slave	Ack (Acknowledge)
29-36	8	Master	first data byte (Offset data byte)
37	1	Slave	Ack (Acknowledge)
38-45	8	Master	2nd data byte
46	1	Slave	Ack (Acknowledge)
			:
		Master	Nth data byte
		Slave	Acknowledge
		Master	Stop

INDEX BLOCK READ PROTOCOL

Master can stop reading any time by issuing the stop bit without waiting until Nth byte (byte count bit 30-37).

Bit	# of bits	From	Description
1	1	Master	Start
2-9	8	Master	D2h
10	1	Slave	Ack (Acknowledge)
11-18	8	Master	Register offset byte (starting byte)
19	1	Slave	Ack (Acknowledge)
20	1	Master	Repeated Start
21-28	8	Master	D3h
29	1	Slave	Ack (Acknowledge)
30-37	8	Slave	Byte count, N (block read back of N bytes)
38	1	Master	Ack (Acknowledge)
39-46	8	Slave	first data byte (Offset data byte)
47	1	Master	Ack (Acknowledge)
48-55	8	Slave	2nd data byte
			Ack (Acknowledge)
			:
		Master	Ack (Acknowledge)
		Slave	Nth data byte
			Not acknowledge
		Master	Stop

PLL3 CONFIG TABLE⁽¹⁾

PLL#_CFB[3,2,1,0]		Comments
0000	PLL3 Disabled	PLL3 off, SRC1 = SRC_Main
0001	100MHz 0.5% SSC Stby	PLL3 on, SRC1 = SRC_Main
0010	100MHz 0.5% SSC	only SRC1 sourced from PLL3
0011	100MHz 1.0% SSC	only SRC1 sourced from PLL3
0100	100MHz 1.5% SSC	only SRC1 sourced from PLL3
0101	100MHz 2.0% SSC	only SRC1 sourced from PLL3
0110	100MHz 2.5% SSC	only SRC1 sourced from PLL3
0111	Reserved	Reserved
1000	1394A 3.3V	only 1394A on SE1 and SE2
1001	1394A&B 3.3V	only 1394A on SE1, 1394B on SE2
1010	1394B 3.3V	only 1394B on SE1 and SE2
1011	27MHz, 3.3V	only 27MHz on SE1 and SE2
1100	25MHz 3.3V	only 25MHz on SE1 and SE2
1101	Reserved	Reserved
1110	Reserved	Reserved
1111	Reserved	Reserved

NOTE:

1. PLL3 spread depend on byte4 bit0 and byte1 bit5, default -0.5%.

DEVICE ID TABLE

ID3,ID2,ID1,IDO		Comments
0000	CK505 56 pin TSSOP	CK505 YC
0001	CK505 64 pin TSSOP	CK505 YC
0010	48 pin QFN	CK505 YC
0011	56 pin QFN	CK505 YC
0100	64 pin QFN	CK505 YC
0101	72 pin QFN	CK505 YC
0110	48 pin SSOP	CK505 YC
0111	56 pin SSOP	CK505 YC
1000	Reserved	CK505 Derivative (non YC)
1001	Reserved	
1010	Reserved	
1011	Reserved	
1100	Reserved	
1101	Reserved	
1110	Reserved	
1111	Reserved	

IO_VOUT [2:0] TABLE

000	0.3V
001	0.4V
010	0.5V
011	0.6V
100	0.7V
101	0.8V
110	0.9V
111	1V

IB TABLE

IB1, IB0	CPU Frequency
01	(N + 0.3333) * resolution
10	(N + 0.6666) * resolution
00, 11	N * resolution

N-PROGRAMMING PROCEDURE

SRC

1. Power on SRC frequency = 100MHz.
2. To change SRC frequency from 100MHz to 50MHz, divide 50 by 0.5 (50 / 0.5 = 100 [decimal] = 64 [hex]).
3. Program Byte 18 with 64h. SRC frequency changes from 100MHz to 50MHz.

CPU

1. Power on CPU frequency = 200MHz. Resolution corresponding to 200MHz is 1.0
2. To change CPU frequency from 200MHz to 100MHz, divide 100 by 1.0- (100 / 1.0 = 100 [decimal] = 64 [hex]).
3. Program Byte 17 with 64h. CPU frequency changes from 200MHz to 100MHz.

CONTROL REGISTERS

BYTE 0

Bit	Output(s) Affected	Description/Function	0	1	Type	Power On
7	FSC	Latched FSC			R	Latched Value
6	FSB	Latched FSB			R	Latched Value
5	FSA	Latched FSA			R	Latched Value
4	iAMT_EN	iAMT Mode	Legacy Mode	Enabled	RW	HW M1 setting ⁽¹⁾
3	Reserved					0
2	SRC_SEL	SRC clock source	PLL1, PLL3_CFG table applies	PLL3, PLL3_CFG table not applicable	RW	0
1	SATA_SEL	SATA source	SRC_main	PLL2 ⁽²⁾	RW	0
0	PD_Restore	SMBUS control registers setting after the power down	Power on default	Save register contents	RW	1

NOTES:

1. Sticky 1, can only be reset by power off.
2. 100MHz, no SSC.

BYTE 1

Bit	Output(s) Affected	Description/Function	0	1	Type	Power On
7	SRC0_sel	Pin13/14 mode select	SRC0	DOT96	RW	0
6	PLL1_SSC_DC	SSC mode selection	Down spread	Center spread	RW	0
5	PLL3_SSC_DC	SSC mode selection	Down spread	Center spread	RW	0
4	PLL3_CFB3				RW	0
3	PLL3_CFB2	Only valid if Byte0 bit2 = 0 See PLL3_CFB table, configure pin17, 18 output mode			RW	0
2	PLL3_CFB1				RW	0
1	PLL3_CFB0				RW	1
0	PCI	PCI select	PLL1	SRC, as byte0 bit2	RW	1

BYTE 2

Bit	Output(s) Affected	Description/Function	0	1	Type	Power On
7	REF	Output Enable	Tristate	Enable	RW	1
6	USB_48	Output Enable	Tristate	Enable	RW	1
5	PCIF5	Output Enable	Tristate	Enable	RW	1
4	PCI4	Output Enable	Tristate	Enable	RW	1
3	PCI3	Output Enable	Tristate	Enable	RW	1
2	PCI2	Output Enable	Tristate	Enable	RW	1
1	PCI1	Output Enable	Tristate	Enable	RW	1
0	PCI0	Output Enable	Tristate	Enable	RW	1

BYTE 3

Bit	Output(s) Affected	Description/Function	0	1	Type	Power On
7	Reserved				RW	1
6	Reserved				RW	1
5	Reserved				RW	1
4	SRC8/ITP	Output Enable	Tristate	Enabled	RW	1
3	SRC7	Output Enable	Tristate	Enabled	RW	1
2	SRC6	Output Enable	Tristate	Enabled	RW	1
1	SRC5	Output Enable	Tristate	Enabled	RW	1
0	SRC4	Output Enable	Tristate	Enabled	RW	1

BYTE 4

Bit	Output(s) Affected	Description/Function	0	1	Type	Power On
7	SRC3	Output Enable	Disabled	Enabled	RW	1
6	SATA/SRC2	Output Enable	Disabled	Enabled	RW	1
5	SRC1	Output Enable	Disabled	Enabled	RW	1
4	SRC0/DOT96	Output Enable	Disabled	Enabled	RW	1
3	CPU1	Output Enable	Disabled	Enabled	RW	1
2	CPU0	Output Enable	Disabled	Enabled	RW	1
1	PLL1_SSC_ON	SSC Enable	Disabled	Enabled	RW	1
0	PLL3_SSC_ON	SSC Enable	Disabled	Enabled	RW	1

BYTE 5

Bit	Output(s) Affected	Description/Function	0	1	Type	Power On
7	CR#_A	Pin1 mode selection	PCI0 mode	CR#_A mode	RW	0
6	CR#_A control	CR#_A control selection	SRC0	SRC2	RW	0
5	CR#_B	Pin3 mode selection	PCI1 mode	CR#_B mode	RW	0
4	CR#_B control	CR#_B control selection	SRC1 ⁽¹⁾	SRC4	RW	0
3	CR#_C	Pin24 mode selection	SRCT3 mode	CR#_C mode	RW	0
2	CR#_C control	CR#_C control selection	SRC0	SRC2	RW	0
1	CR#_D	Pin25 mode selection	SRCC3 mode	CR#_D mode	RW	0
0	CR#_D control	CR#_D control selection	SRC1	SRC4	RW	0

NOTE:

1. Only when SRC1 is SRC Clock.

BYTE 6⁽¹⁾

Bit	Output(s) Affected	Description/Function	0	1	Type	Power On
7	CR#_E	Pin 35 mode selection, control SRC6	SRCC7 mode	CR#_E mode	RW	0
6	CR#_F	Pin 36 mode selection, control SRC8	SRCT7 mode	CR#_F mode	RW	0
5	Reserved				RW	0
4	Reserved				RW	0
3	Reserved				RW	0
2	Reserved				RW	0
1	SSCD_STP_CRTL	If set, SSCD stop with PCI_STOP#	Freerunning	Stoppable	RW	0
0	SRC_STP_CRTL	If set, SRCs stop with PCI_STOP#	Freerunning	Stoppable	RW	0

NOTE:

1. STOP - CPUT and SRCT stay high, CPUC and SRCC stay low.

BYTE 7

Bit	Output(s) Affected	Description / Function	0	1	Type	Power On
7		Revision ID				0
6		Revision ID				0
5		Revision ID				0
4		Revision ID				0
3		Vendor ID				0
2		Vendor ID				1
1		Vendor ID				0
0		Vendor ID				1

BYTE 8

Bit	Output(s) Affected	Description / Function	0	1	Type	Power On
7	Device_ID3	See device ID table			R	
6	Device_ID2				R	
5	Device_ID1				R	
4	Device_ID0				R	
3					RW	0
2					RW	0
1	SE1_OE	Output Enable	Disabled	Enabled	RW	0
0	SE2_OE	Output Enable	Disabled	Enabled	RW	0

BYTE 9

Bit	Output(s) Affected	Description / Function	0	1	Type	Power On
7	PCIF5 with PCI_STOP#	Freerunning	Free running	stoppable	RW	0
6	LTE_STRAP	Over-clocking Enable (N programming)	normal	No overclocking	R	0
5	REF Drive Strength	Strength control	1x	2x	RW	1
4		Only valid when Byte9 bit3 is 1	Hi-Z	REF/N mode	RW	0
3		Test Mode entry control	Normal operation	Test mode, controlled by byte9 bit 4	RW	0
2	IO_VOUT2				RW	1
1	IO_VOUT1	Programmable IO_Vout voltage			RW	0
0	IO_VOUT0				RW	1

BYTES 10 + 11 - RESERVED

BYTE 12 - BYTE COUNT - DEFAULT 0x0D

BYTE 13

Bit	Output(s) Affected	Description / Function	0	1	Type	Power On
7	48M	Strength control	1	1.2	RW	0
6	REF	Strength control	1	1.2	RW	0
5	PCIF5	Strength control	1	1.2	RW	0
4	PCI4	Strength control	1	1.2	RW	0
3	PCI3	Strength control	1	1.2	RW	0
2	PCI2	Strength control	1	1.2	RW	0
1	PCI1	Strength control	1	1.2	RW	0
0	PCI0	Strength control	1	1.2	RW	0

BYTE 14

Bit	Output(s) Affected	Description / Function	0	1	Type	Power On
7	SRC skew selection		250ps	400ps	RW	0
6	Reserved				RW	0
5	Reserved				RW	0
4	SRC3, 4, 5, 6	Strength(output impedance)	17Ω	25Ω	RW	0
3	SRC2, 7, 8	Strength	17Ω	25Ω	RW	0
2	CPU strength	Strength	17Ω	25Ω	RW	0
1	SRC0/ DOT strength	Strength	17Ω	25Ω	RW	0
0	SRC1/ PLL3CLK Strength	Strength	17Ω	25Ω	RW	0

BYTE 15, WATCH DOG⁽¹⁾

Bit	Output(s) Affected	Description / Function	0	1	Type	Power On
7	Watch Dog Enable	Watch Dog Alarm Enable	Disabled	Enabled	RW	0
6	Watch Dog Select	Watch Dog Hard/Soft Alarm Select	Hard Alarm Only	Hard and Soft Alarm	RW	0
5	Watch Dog Hard Alarm Status	Watch Dog Hard Alarm Status	Normal	Alarm	R	
4	Watch Dog Soft Alarm Status	Watch Dog Soft Alarm Status	Normal	Alarm	R	
3	Watch Dog control	Watch Dog Time Base Control	290ms base	1160ms base	RW	0
2	WD_1_Timer2	WatchDog_1_Alarm Timer Default is 7*290ms			RW	1
1	WD_1_Timer1				RW	1
0	WD_1_Timer0				RW	1

NOTE:

1. Hard Alarm switch to HW FS frequency.

BYTE 16

Bit	Output(s) Affected	Description / Function	0	1	Type	Power On
7	WDEAPD	Set Byte15 bit7 = 1 after Power Down to enable the watch dog after the power down	Disabled	Enabled	RW	0
6	Reserved				RW	0
5	Reserved				RW	0
4	Reserved				RW	0
3	Reserved				RW	0
2	IB1	Increment bit1, fine tune CPU frequency	See IB table		RW	0
1	IB0	Increment bit0	See IB table		RW	0
0	CPUN8				RW	FS latch

BYTE 17 (PLL1)

Bit	Output(s) Affected	Description / Function	0	1	Type	Power On
7	CPUN7	CPU frequency = N*Resolution (see Resolution table, N-Programming Procedure)			RW	FS latch
6	CPUN6				RW	
5	CPUN5				RW	
4	CPUN4				RW	
3	CPUN3				RW	
2	CPUN2				RW	
1	CPUN1				RW	
0	CPUN0				RW	

BYTE 18 (PLL3)

Bit	Output(s) Affected	Description / Function	0	1	Type	Power On
7	PN 7	SRC frequency = N*Resolution (see Resolution table, N-Programming Procedure)			RW	100MHz
6	PN 6				RW	
5	PN 5				RW	
4	PN 4				RW	
3	PN 3				RW	
2	PN 2				RW	
1	PN 1				RW	
0	PN 0				RW	

BYTE 19, CLOCK SOURCE SELECTION, WRITEN AFTER STOP BIT

Bit	Output(s) affected	Description/ Function	0	1	Type	Power On
7	CPU MODE Control	Will be reset to 0 during the Hard Alarm	CPU Mode is based on Hardware SFS	CPU Mode is based on SFS	RW	0
6	SFSC				RW	LATCH
5	SFSB				RW	Latch
4	SFSA				RW	Latch
3	N programming enable		enable	disable	RW	Power on LTE latch
2	SRC1 source		controlled by PLL3_CFB[3:0] and byte0 bit2	PLL2	RW	0
1	PCI source		Follow byte1 bit0	PLL2	RW	0
0	Reserved	-	-	-	-	0

DC OPERATING CHARACTERISTICS

Following Conditions Apply Unless Otherwise Specified:

Operating Condition: $T_A = 0^{\circ}\text{C}$ to $+70^{\circ}\text{C}$, Supply Voltage: $V_{DD} = 3.3\text{V} \pm 5\%$

Symbol	Parameter	Test Conditions	Min.	Max.	Unit
V _{DD_3.3}	Supply Voltage	5 %	3.125	3.465	V
V _{IH}	Input HIGH Voltage (SE) ⁽¹⁾		2	V _{DD} + 0.3	V
V _{IL}	Input LOW Voltage (SE) ⁽¹⁾		V _{SS} - 0.3	0.8	V
V _{IH_FS_Test}	Input HIGH Voltage (SE) ⁽²⁾		2	V _{DD} + 0.3	V
V _{IH_FS_Normal}	Input HIGH Voltage (FS) ⁽²⁾		0.7	1.5	V
V _{IL_FS_Normal}	Input LOW Voltage (FS) ⁽²⁾		V _{SS} - 0.3	0.35	V
I _{IL}	Input Leakage Current ⁽³⁾	0 < V _{IN} < V _{DD}	-5	+5	μA
V _{OH}	Output HIGH Voltage (SE) ⁽⁴⁾	I _{OH} = -1 mA	2.4	—	V
V _{OL}	Output LOW Voltage (SE) ⁽⁴⁾	I _{OL} = 1 mA	—	.4	V
V _{DD_IO}	LOW Voltage Differential		0.72	0.88	V
C _{IN}	Input Pin Capacitance		1.5	5	pF
C _{OUT}	Output Pin Capacitance		—	6	pF
I _{DD_CFG1_3.3V}	Operating Supply Current, default configuration		—	250	mA
I _{DD_CFG2_3.3V}	Operating Supply Current, PLL3 differential out		—	250	mA
I _{DD_CFG3_3.3V}	Operating Supply Current, PLL3 single-ended out		—	250	mA
I _{DD_IO_0.8V}	Differential IO Current, all outputs enabled		25	80	mA
I _{DD_PWRDWN_3.3V}	Power Down Supply Current		—	1	mA
I _{DD_PWRDWN_0.8V}	Power Down Supply Current		—	0.1	mA
I _{DD_M1_3.3V}	MT Mode Supply Current		—	25	mA
I _{DD_M1_0/8V}	MT Mode Supply Current		—	0.8	mA

NOTES:

1. All inputs referenced to 3.3V power supply.
2. Frequency select inputs which have tri-level input.
3. Input leakage current does not include inputs with pull-up or pull-down resistors.
4. Signal edge is required to be monotonic when transitioning through this region.

ELECTRICAL CHARACTERISTICS - CPU, SRC, AND DOT96 0.7 DIFFERENTIAL PAIR⁽¹⁾

Following Conditions Apply Unless Otherwise Specified:

Operating Condition: TA = 0°C to +70°C, Supply Voltage: V_{DD} = 3.3V ± 5%; C_L = 2pF

Symbol	Parameter	Test Conditions	Min.	Typ.	Max.	Unit
V _{HIGH}	Voltage HIGH ⁽²⁾	Statistical measurement on single-ended signal using oscilloscope math function	660	—	850	mV
V _{LOW}	Voltage LOW ⁽²⁾		-150	—	+150	
V _{OV5}	Max Voltage ⁽²⁾	Measurement on single-ended signal using absolute value	—	—	1150	mV
V _{UD5}	Min Voltage ⁽²⁾		-300	—	—	
V _{CROSS(ABS)}	Crossing Voltage (abs) ⁽²⁾		250	—	550	mV
d - V _{CROSS}	Crossing Voltage (var) ⁽²⁾	Variation of crossing over all edges	—	—	140	mV
ppm	Static Error ^(2,3)	See T _{PERIOD} Min. - Max. values	—	—	0	ppm
T _{PERIOD}	Average Period ⁽³⁾	400MHz nominal / -0.5% spread	2.4993	—	2.5133	ns
		333.33MHz nominal / -0.5% spread	2.9991	—	3.016	
		266.66MHz nominal / -0.5% spread	3.7489	—	3.77	
		200MHz nominal / -0.5% spread	4.9985	—	5.0266	
		166.66MHz nominal / -0.5% spread	5.9982	—	6.032	
		133.33MHz nominal / -0.5% spread	7.4978	—	7.54	
		100MHz nominal / -0.5% spread	9.997	—	10.0533	
		96MHz nominal	10.4135	—	10.4198	
T _{ABSMIN}	Absolute Min Period ^(2,3)	400MHz nominal / -0.5% spread	2.4143	—	—	ns
		333.33MHz nominal / -0.5% spread	2.9141	—	—	
		266.66MHz nominal / -0.5% spread	3.6639	—	—	
		200MHz nominal / -0.5% spread	4.9135	—	—	
		166.66MHz nominal / -0.5% spread	5.9132	—	—	
		133.33MHz nominal / -0.5% spread	7.4128	—	—	
		100MHz nominal / -0.5% spread	9.912	—	—	
		96MHz nominal	10.1635	—	—	
t _r	Rise Time ⁽²⁾	V _{OL} = 0.175V, V _{OH} = 0.525V	175	—	700	ps
t _f	Fall Time ⁽²⁾	V _{OL} = 0.175V, V _{OH} = 0.525V	175	—	700	ps
d-t _r	Rise Time Variation ⁽²⁾		—	—	125	ps
d-t _f	Fall Time Variation ⁽²⁾		—	—	125	ps
dt ₃	Duty Cycle ⁽²⁾	Measurement from differential waveform	45	—	55	%

NOTES:

- SRC clock outputs run only at 100MHz.
- This parameter is guaranteed by design, but not 100% production tested.
- All long term accuracy and clock period specifications are guaranteed with the assumption that the REF output is at 14.31818MHz.

ELECTRICAL CHARACTERISTICS - CPU, SRC, AND DOT96 0.7 CURRENT MODE DIFFERENTIAL PAIR, CONTINUED⁽¹⁾

Following Conditions Apply Unless Otherwise Specified:

Operating Condition: TA = 0°C to +70°C, Supply Voltage: VDD = 3.3V ± 5%; CL = 2pF

Symbol	Parameter	Test Conditions	Min.	Typ.	Max.	Unit
tsk3	Skew, CPU[1:0] ⁽²⁾	VT = 50%	—	—	100	ps
	Skew, CPU2 ⁽²⁾		—	—	250	
	Skew, SRC ⁽²⁾		—	—	250	
t _{CYC-CYC}	Jitter, Cycle to Cycle, CPU[1:0] ⁽²⁾	Measurement from differential waveform	—	—	85	ps
	Jitter, Cycle to Cycle, CPU2 ⁽²⁾		—	—	100	
	Jitter, Cycle to Cycle, SRC ⁽²⁾		—	—	125	
	Jitter, Cycle to Cycle, DOT96 ⁽²⁾		—	—	250	

NOTES:

- SRC clock outputs run only at 100MHz.
- This parameter is guaranteed by design, but not 100% production tested.

ELECTRICAL CHARACTERISTICS - PCICLK / PCICLK_F

Following Conditions Apply Unless Otherwise Specified:

Operating Condition: TA = 0°C to +70°C, Supply Voltage: VDD = 3.3V ± 5%; CL = 10 - 30pF

Symbol	Parameter	Test Conditions	Min.	Typ.	Max.	Unit
ppm	Static Error ^(1,2)	See Tperiod Min. - Max. values	—	—	0	ppm
T _{PERIOD}	Clock Period ⁽²⁾	33.33MHz output nominal	29.991	—	30.009	ns
		33.33MHz outputs spread	29.991	—	30.1598	
VOH	Output HIGH Voltage	IOH = -1mA	2.4	—	—	V
VOL	Output LOW Voltage	IOL = 1mA	—	—	0.55	V
IOH	Output HIGH Current	VOH at Min. = 1V	-33	—	—	mA
		VOH at Max. = 3.135V	—	—	-33	
IOL	Output LOW Current	VOL at Min. = 1.95V	30	—	—	mA
		VOL at Max. = 0.4V	—	—	38	
	Edge Rate ⁽¹⁾	Rising edge rate	1	—	4	V/ns
	Edge Rate ⁽¹⁾	Falling edge rate	1	—	4	V/ns
tr1	Rise Time ⁽¹⁾	VOL = 0.8V, VOH = 2V	0.3	—	1.2	ns
tF1	Fall Time ⁽¹⁾	VOL = 0.8V, VOH = 2V	0.3	—	1.2	ns
dT1	Duty Cycle ⁽¹⁾	VT = 1.5V	45	—	55	%
tsk1	Skew ⁽¹⁾	VT = 1.5V	—	—	250	ps
t _{CYC-CYC}	Jitter, Cycle to Cycle ⁽¹⁾	VT = 1.5V	—	—	500	ps

NOTES:

- This parameter is guaranteed by design, but not 100% production tested.
- All long term accuracy and clock period specifications are guaranteed with the assumption that the REF output is at 14.31818MHz.

ELECTRICAL CHARACTERISTICS, 48MHZ, USB

Following Conditions Apply Unless Otherwise Specified:

Operating Condition: $T_A = 0^{\circ}\text{C}$ to $+70^{\circ}\text{C}$, Supply Voltage: $V_{DD} = 3.3\text{V} \pm 5\%$; $C_L = 10 - 20\text{pF}$

Symbol	Parameter	Test Conditions	Min.	Typ.	Max.	Unit
ppm	Static Error ^(1,2)	See Tperiod Min. - Max. values	—	—	0	ppm
TPERIOD	Clock Period ⁽²⁾	48MHz output nominal	20.8257	—	20.834	ns
VOH	Output HIGH Voltage	IOH = -1mA	2.4	—	—	V
VOL	Output LOW Voltage	IOL = 1mA	—	—	0.55	V
IOH	Output HIGH Current	VOH at Min. = 1V	-29	—	—	mA
		VOH at Max. = 3.135V	—	—	-23	
IOL	Output LOW Current	VOL at Min. = 1.95V	29	—	—	mA
		VOL at Max. = 0.4V	—	—	27	
	Edge Rate ⁽¹⁾	Rising edge rate	1	—	2	V/ns
	Edge Rate ⁽¹⁾	Falling edge rate	1	—	2	V/ns
tr1	Rise Time ⁽¹⁾	VOL = 0.8V, VOH = 2V	0.5	—	1.2	ns
tf1	Fall Time ⁽¹⁾	VOL = 0.8V, VOH = 2V	0.5	—	1.2	ns
dT1	Duty Cycle ⁽¹⁾	VT = 1.5V	45	—	55	%
tCYC-CYC	Jitter, Cycle to Cycle		—	—	350	ps

NOTES:

1. This parameter is guaranteed by design, but not 100% production tested.
2. All long term accuracy and clock period specifications are guaranteed with the assumption that the REF output is at 14.31818MHz.

ELECTRICAL CHARACTERISTICS - REF-14.318MHZ

Following Conditions Apply Unless Otherwise Specified:

Operating Condition: $T_A = 0^{\circ}\text{C}$ to $+70^{\circ}\text{C}$, Supply Voltage: $V_{DD} = 3.3\text{V} \pm 5\%$; $C_L = 10 - 20\text{pF}$

Symbol	Parameter	Test Conditions	Min.	Typ.	Max.	Unit
ppm	Long Accuracy ⁽¹⁾	See Tperiod Min. - Max. values	—	—	0	ppm
TPERIOD	Clock Period	14.318MHz output nominal	69.827	—	69.855	ns
VOH	Output HIGH Voltage ⁽¹⁾	IOH = -1mA	2.4	—	—	V
VOL	Output LOW Voltage ⁽¹⁾	IOL = 1mA	—	—	0.4	V
IOH	Output HIGH Current	VOH at Min. = 1V	-33	—	—	mA
		VOH at Max. = 3.135V	—	—	-33	
IOL	Output LOW Current	VOL at Min. = 1.95V	30	—	—	mA
		VOL at Max. = 0.4V	—	—	38	
	Edge Rate ⁽¹⁾	Rising edge rate	1	—	4	V/ns
	Edge Rate ⁽¹⁾	Falling edge rate	1	—	4	V/ns
tr1	Rise Time ⁽¹⁾	VOL = 0.8V, VOH = 2V	0.3	—	1.2	ns
tf1	Fall Time ⁽¹⁾	VOL = 0.8V, VOH = 2V	0.3	—	1.2	ns
dT1	Duty Cycle ⁽¹⁾	VT = 1.5V	45	—	55	%
tCYC-CYC	Jitter, Cycle to Cycle ⁽¹⁾	VT = 1.5V	—	—	1000	ps

NOTE:

1. This parameter is guaranteed by design, but not 100% production tested.

MISC. AC TIMING REQUIREMENTS

Symbol	Parameter	Min.	Max.	Unit
T _{STABLE}	All Clock Stabilization from Power-Up	—	<1.8	ns
T _{DRIVE_SRC}	SRC Output Driven After PCI_STOP# De-assertion	—	15	ns
T _{DRIVE_PCI}	PCI Output Driven After PCI_STOP# De-assertion	—	15	us
T _{DRIVE_CR#}	SRC Output Driven After CR# De-assertion	—	15	ns
T _{DRIVE_PWRDWN}	Differential Output Enable after PWRDWN De-assertion	—	300	ns
T _{RISE_Control_Sig}	Rise Time for All Control Inputs (LVTTTL 20-80%)	—	10	us
T _{FALL_Control_Sig}	Fall time for All Control Inputs (LVTTTL 20-80%)	—	10	ns

PCI STOP FUNCTIONALITY

PCI_STOP#	SRC	SRC#	PCI
1	Normal	Normal	33MHz
0	High	Low	Low

PCI_STOP# ASSERTION (TRANSITION FROM '1' TO '0')

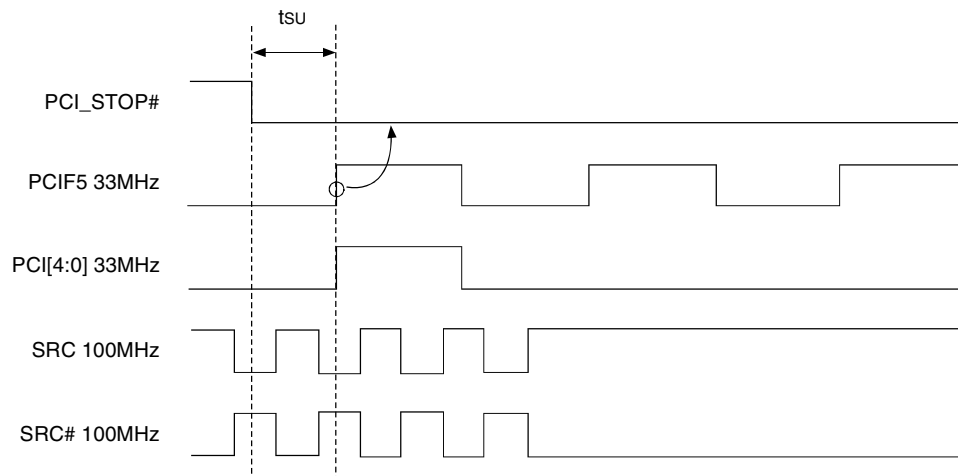

PCI_STOP# - DE-ASSERTION (TRANSITION FROM '0' TO '1')

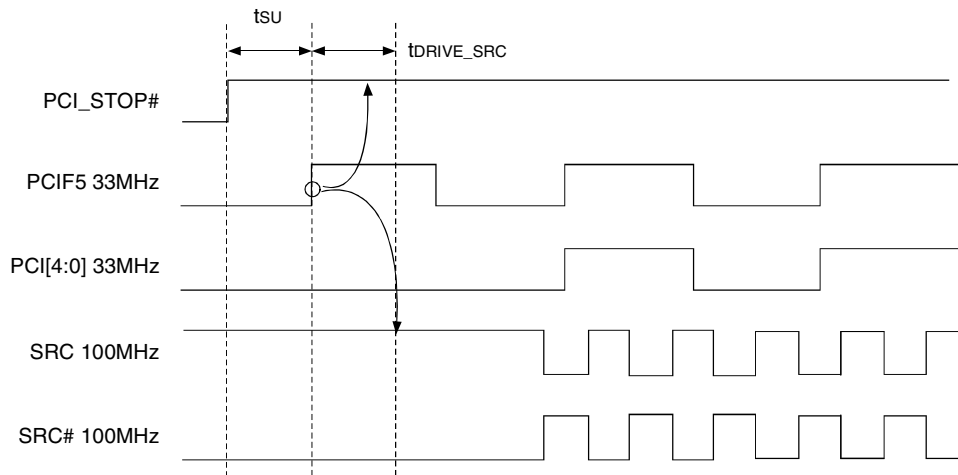

CPU STOP FUNCTIONALITY

The CPU_STOP# signal is an active low input controlling the CPU outputs. This signal can be asserted asynchronously.

CPU_STOP#	CPU	CPU#
1	Normal	Normal
0	High	Low

CPU_STOP# ASSERTION (TRANSITION FROM '1' TO '0')

Asserting CPU_STOP# pin stops all CPU outputs that are set to be stoppable after their next transition. When the SMBus CPU_STOP tri-state bit corresponding to the CPU output of interest is programmed to a '0', CPU output will stop CPU_True = High and CPU_Complement = Low. When the SMBus CPU_STOP tri-state bit corresponding to the CPU output of interest is programmed to a '1', CPU outputs will be tri-stated.

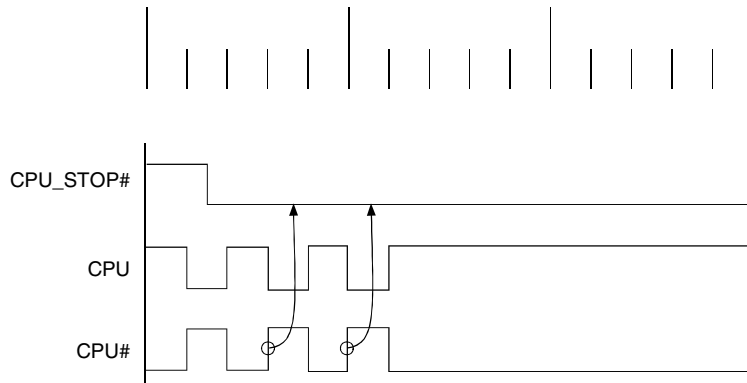

CPU_STOP# - DE-ASSERTION (TRANSITION FROM '0' TO '1')

With the de-assertion of CPU_STOP# all stopped CPU outputs will resume without a glitch. The maximum latency from the de-assertion to active outputs is two to six CPU clock periods. If the control register tristate bit corresponding to the output of interest is programmed to '1', then the stopped CPU outputs will be driven High within 10nS of CPU_STOP# de-assertion to a voltage greater than 200mV.

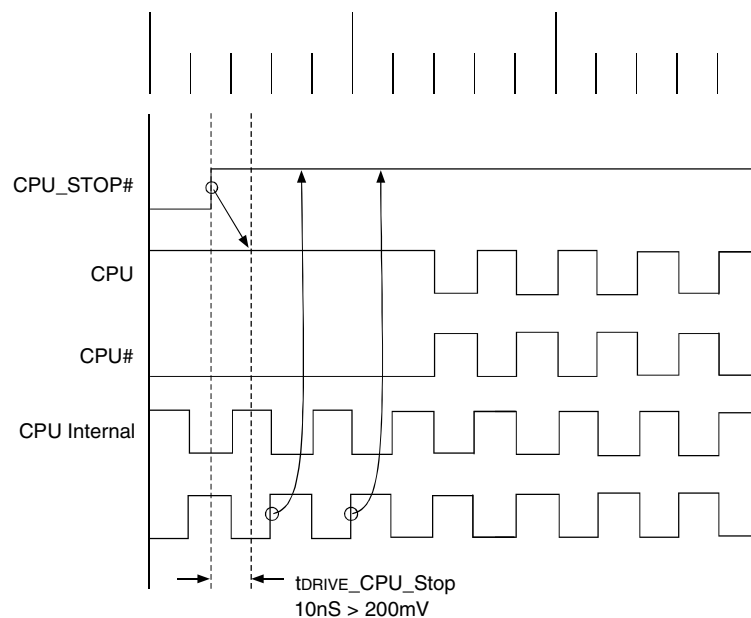

PD# ASSERTION

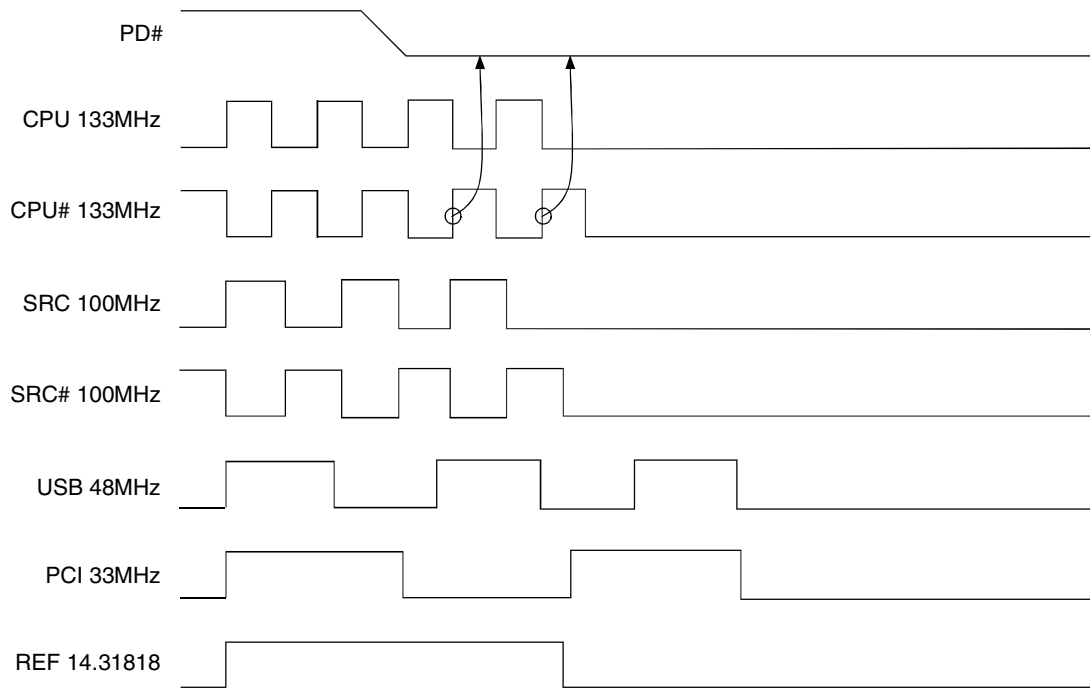

PD# DE-ASSERTION

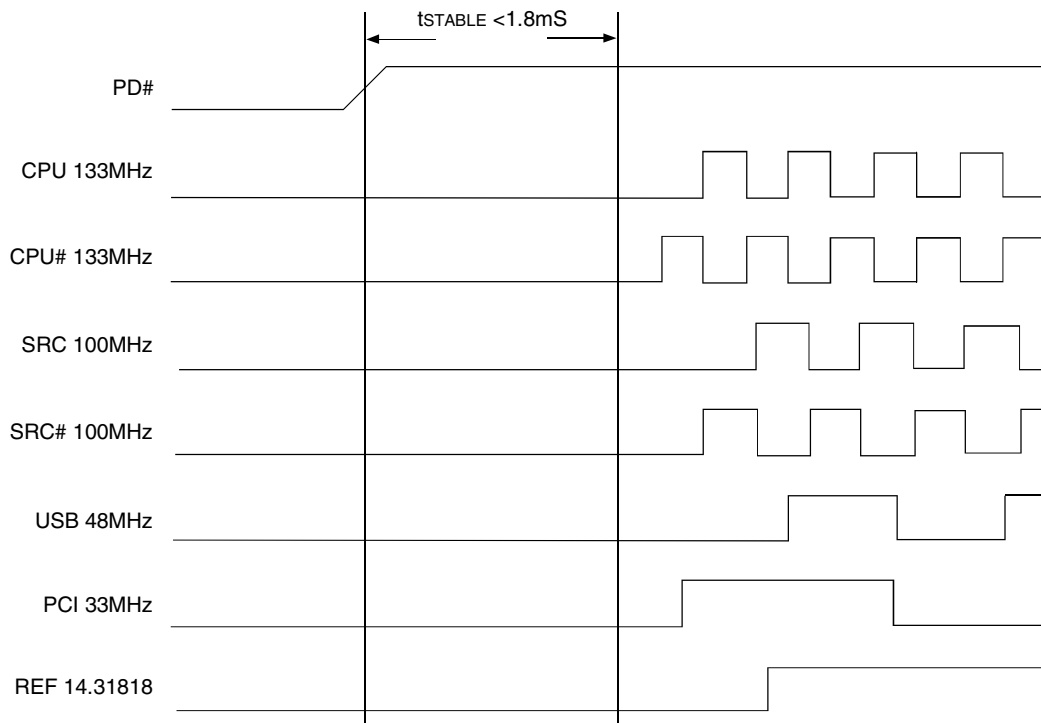

ORDERING INFORMATION

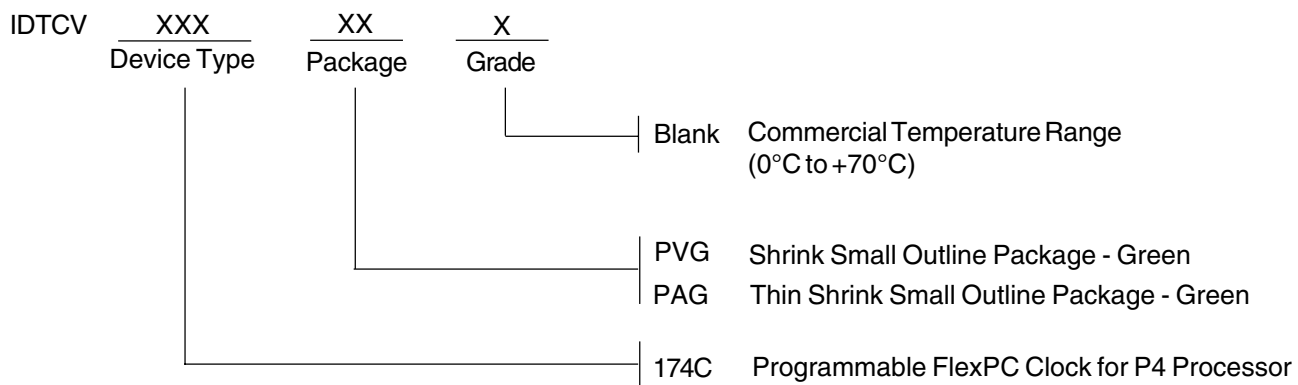

May 22, 2006

Final Release.

IMPORTANT NOTICE AND DISCLAIMER

RENESAS ELECTRONICS CORPORATION AND ITS SUBSIDIARIES (“RENESAS”) PROVIDES TECHNICAL SPECIFICATIONS AND RELIABILITY DATA (INCLUDING DATASHEETS), DESIGN RESOURCES (INCLUDING REFERENCE DESIGNS), APPLICATION OR OTHER DESIGN ADVICE, WEB TOOLS, SAFETY INFORMATION, AND OTHER RESOURCES “AS IS” AND WITH ALL FAULTS, AND DISCLAIMS ALL WARRANTIES, EXPRESS OR IMPLIED, INCLUDING, WITHOUT LIMITATION, ANY IMPLIED WARRANTIES OF MERCHANTABILITY, FITNESS FOR A PARTICULAR PURPOSE, OR NON-INFRINGEMENT OF THIRD-PARTY INTELLECTUAL PROPERTY RIGHTS.

These resources are intended for developers who are designing with Renesas products. You are solely responsible for (1) selecting the appropriate products for your application, (2) designing, validating, and testing your application, and (3) ensuring your application meets applicable standards, and any other safety, security, or other requirements. These resources are subject to change without notice. Renesas grants you permission to use these resources only to develop an application that uses Renesas products. Other reproduction or use of these resources is strictly prohibited. No license is granted to any other Renesas intellectual property or to any third-party intellectual property. Renesas disclaims responsibility for, and you will fully indemnify Renesas and its representatives against, any claims, damages, costs, losses, or liabilities arising from your use of these resources. Renesas' products are provided only subject to Renesas' Terms and Conditions of Sale or other applicable terms agreed to in writing. No use of any Renesas resources expands or otherwise alters any applicable warranties or warranty disclaimers for these products.

(Disclaimer Rev.1.01 Jan 2024)

Corporate Headquarters

TOYOSU FORESIA, 3-2-24 Toyosu,
Koto-ku, Tokyo 135-0061, Japan
www.renesas.com

Trademarks

Renesas and the Renesas logo are trademarks of Renesas Electronics Corporation. All trademarks and registered trademarks are the property of their respective owners.

Contact Information

For further information on a product, technology, the most up-to-date version of a document, or your nearest sales office, please visit www.renesas.com/contact-us/.