

# DAC1617D1G0

Dual 16-bit DAC, LVDS interface, up to 1 Gbps, x2, x4 and x8 interpolating

Rev. 4 — 12 December 2012

Product data sheet

## 1. General description

---

The DAC1617D1G0 is a high-speed 16-bit dual channel Digital-to-Analog Converter (DAC) with selectable x2, x4 and x8 interpolation filters. The device is optimized for multi-carrier and broadband wireless transmitters at sample rates of up to 1 Gbps. Supplied from a 3.3 V and a 1.8 V source, the DAC1617D1G0 integrates a differential scalable output current up to 34 mA.

The Serial Peripheral Interface (SPI) provides full control of the DAC1617D1G0.

The DAC1617D1G0 integrates a Low Voltage Differential Signaling (LVDS) Double Data Rate (DDR) receiver interface, with an on-chip 100  $\Omega$  termination. The LVDS DDR interface accepts a multiplex input data stream such as interleaved or folded. An internal LVDS input auto-calibration ensures the robustness and stability of the interface.

Digital on-chip modulation converts the complex I and Q inputs from baseband to IF. A 40-bit Numerically Controlled Oscillator (NCO) sets the mixer frequency. High resolution internal gain, phase and offset control provide outstanding image and Local Oscillator (LO) signal rejection at the system analog modulator output.

An inverse  $(\sin x) / x$  function ensures a controlled flatness 0.5 dB for high bandwidths at the DAC output.

Multiple device synchronization allows synchronization of the outputs of multiple DAC devices. MDS guarantees a maximum skew of one output clock period between several devices.

The DAC1617D1G0 includes a very low noise capacitor-free integrated Phase-Locked Loop (PLL) multiplier which generates a DAC clock rate from the LVDS clock rate.

The DAC1617D1G0 is available in an HVQFN72 package (10 mm  $\times$  10 mm).



## 2. Features and benefits

- Dual-channel 16-bit resolution
- 1 Gsps maximum update rate
- Selectable x2, x4 and x8 interpolating filters
- Very low noise capacitor-free integrated Phase-Locked Loop (PLL)
- Embedded Numerically Controlled Oscillator (NCO) with 40-bit programmable frequency
- Embedded complex(I/Q) digital IF modulator
- 1.8 V and 3.3 V power supplies
- LVDS DDR compatible input interface with on-chip 100  $\Omega$  terminations
- LVDS DDR input clock up to 370 MHz
- LVDS or LVPECL compatible DAC clock
- Interleaved or folded I and Q data input mode
- Synchronization of multiple DAC devices
- 3-wire or 4-wire mode SPI interface
- Differential scalable output current from 8.1 mA to 34 mA
- External analog offset control (10-bit auxiliary DACs)
- High resolution internal digital gain and offset control to support high performance IQ-modulator image rejection
- Internal phase correction
- Inverse (sin x) / x function
- Power-down mode and Sleep mode; 5-bit NCO low-power mode
- On-chip 1.25 V reference
- Industrial temperature range  $-40\text{ }^{\circ}\text{C}$  to  $+85\text{ }^{\circ}\text{C}$
- 72 pins small form factor HVQFN package

## 3. Applications

- Wireless infrastructure: LTE, WiMAX, GSM, CDMA, WCDMA, TD-SCDMA
- Communications: LMDS/MMDS, point-to-point
- Direct Digital Synthesis (DDS)
- Broadband wireless systems
- Digital radio links
- Instrumentation
- Automated Test Equipment (ATE)

## 4. Ordering information

Table 1. Ordering information

Type number	Package		Version
	Name	Description	
DAC1617D1G0HN	HVQFN72	plastic thermal enhanced very thin quad flat package; no leads; 72 terminals; body 10 × 10 × 0.85 mm	SOT813-3

## 5. Block diagram

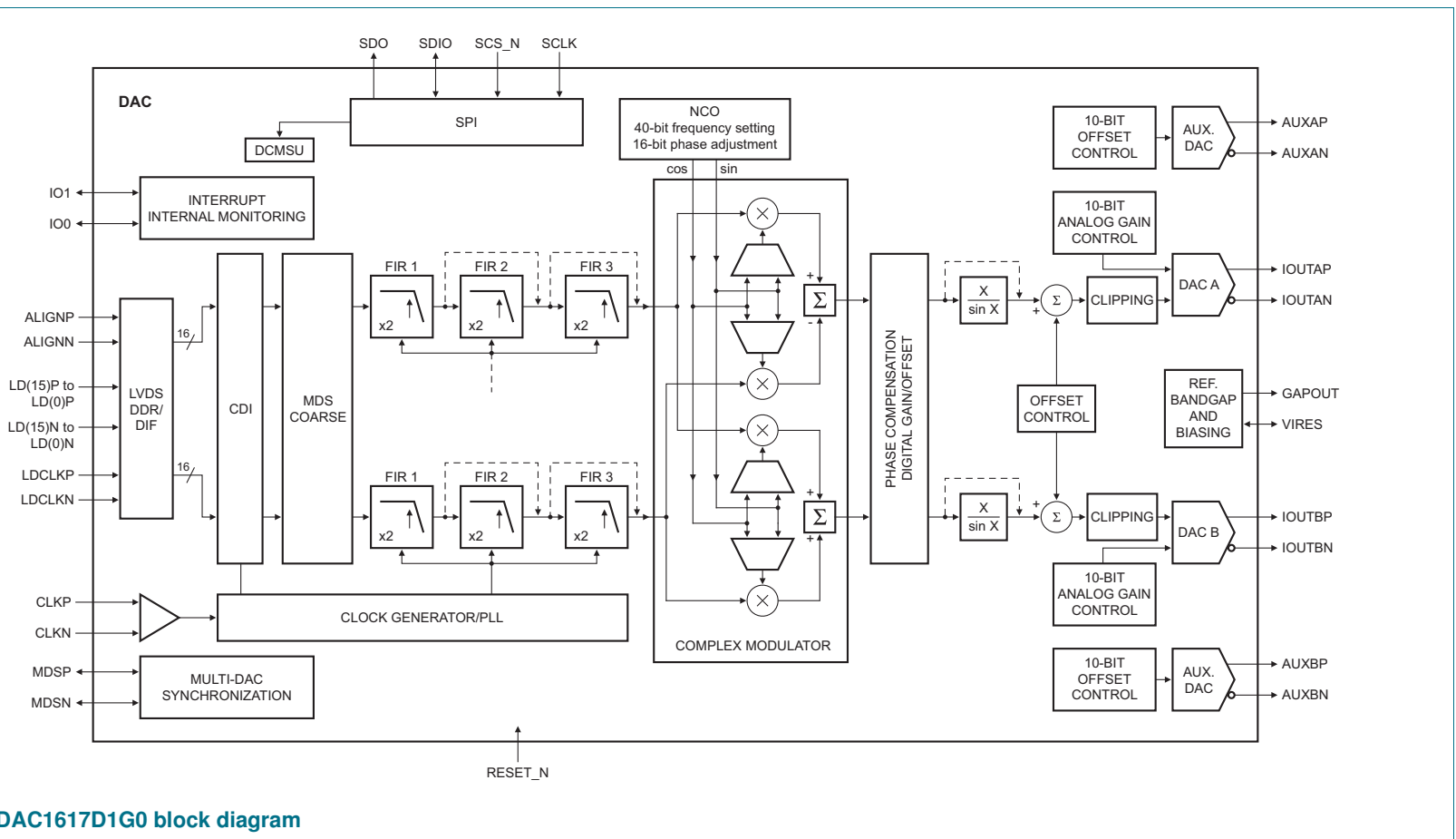

Fig 1. DAC1617D1G0 block diagram

## 6. Pinning information

### 6.1 Pinning

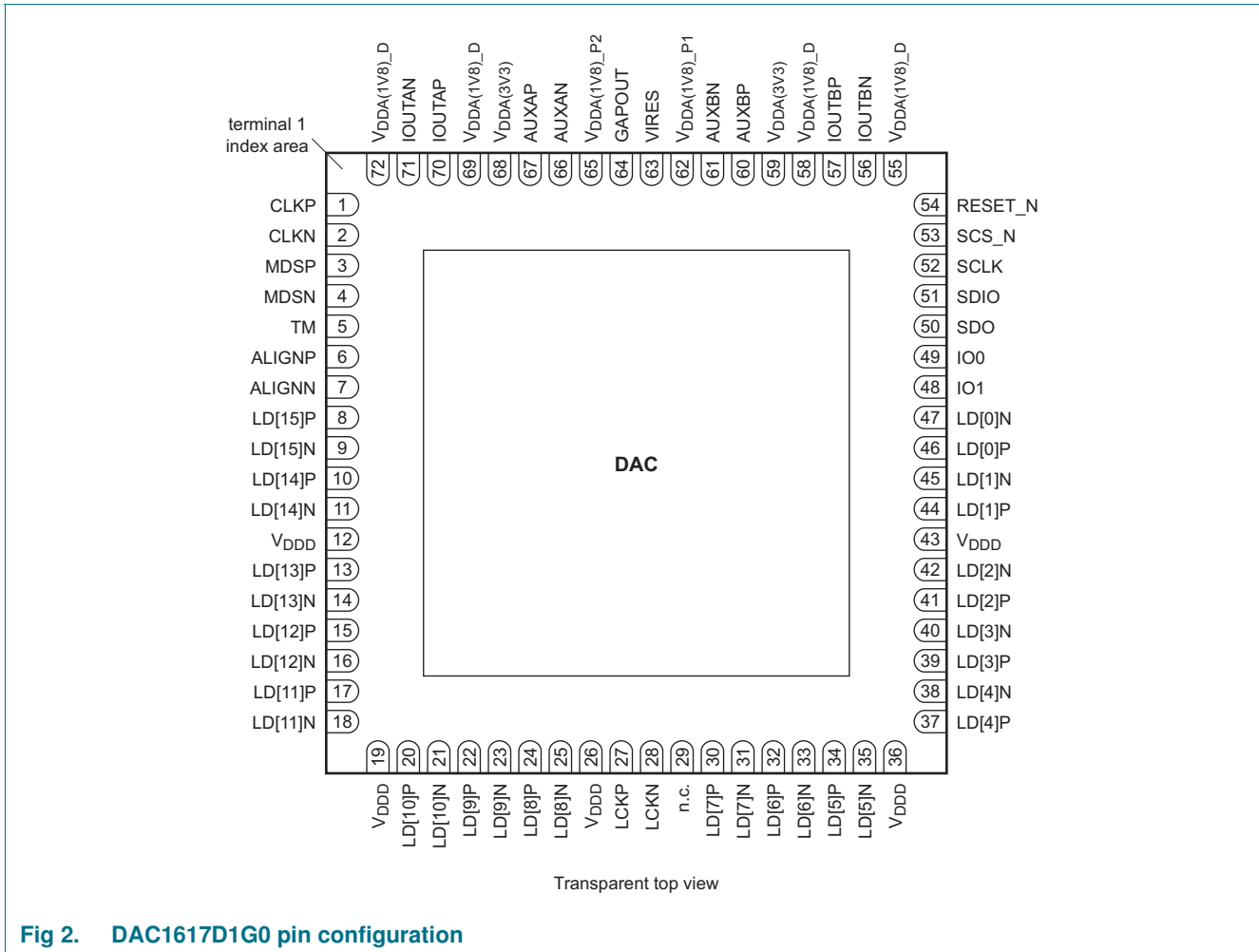

Fig 2. DAC1617D1G0 pin configuration

### 6.2 Pin description

Table 2. Pin description

Symbol	Pin	Type <sup>[1]</sup>	Description
CLKP	1	I	DAC clock positive input
CLKN	2	I	DAC clock negative input
MDSP	3	IO	multi-device synchronization positive signal
MDSN	4	IO	multi-device synchronization negative signal
TM	5	I	Test mode selection (connect to GND)
ALIGNP	6	I	positive input for data alignment
ALIGNN	7	I	negative input for data alignment
LD[15]P	8	I	LVDS positive input bit 15 <sup>[2]</sup>
LD[15]N	9	I	LVDS negative input bit 15 <sup>[2]</sup>

Table 2. Pin description ...continued

Symbol	Pin	Type <sup>[1]</sup>	Description
LD[14]P	10	I	LVDS positive input bit 14 <sup>[2]</sup>
LD[14]N	11	I	LVDS negative input bit 14 <sup>[2]</sup>
V <sub>DDD</sub>	12	P	digital power supply
LD[13]P	13	I	LVDS positive input bit 13 <sup>[2]</sup>
LD[13]N	14	I	LVDS negative input bit 13 <sup>[2]</sup>
LD[12]P	15	I	LVDS positive input bit 12 <sup>[2]</sup>
LD[12]N	16	I	LVDS negative input bit 12 <sup>[2]</sup>
LD[11]P	17	I	LVDS positive input bit 11 <sup>[2]</sup>
LD[11]N	18	I	LVDS negative input bit 11 <sup>[2]</sup>
V <sub>DDD</sub>	19	P	digital power supply
LD[10]P	20	I	LVDS positive input bit 10 <sup>[2]</sup>
LD[10]N	21	I	LVDS negative input bit 10 <sup>[2]</sup>
LD[9]P	22	I	LVDS positive input bit 9 <sup>[2]</sup>
LD[9]N	23	I	LVDS negative input bit 9 <sup>[2]</sup>
LD[8]P	24	I	LVDS positive input bit 8 <sup>[2]</sup>
LD[8]N	25	I	LVDS negative input bit 8 <sup>[2]</sup>
V <sub>DDD</sub>	26	P	digital power supply
LCKP	27	I	LVDS positive data clock input
LCKN	28	I	LVDS negative data clock input
n.c.	29	G	not connected
LD[7]P	30	I	LVDS positive input bit 7 <sup>[2]</sup>
LD[7]N	31	I	LVDS negative input bit 7 <sup>[2]</sup>
LD[6]P	32	I	LVDS positive input bit 6 <sup>[2]</sup>
LD[6]N	33	I	LVDS negative input bit 6 <sup>[2]</sup>
LD[5]P	34	I	LVDS positive input bit 5 <sup>[2]</sup>
LD[5]N	35	I	LVDS negative input bit 5 <sup>[2]</sup>
V <sub>DDD</sub>	36	P	digital power supply
LD[4]P	37	I	LVDS positive input bit 4 <sup>[2]</sup>
LD[4]N	38	I	LVDS negative input bit 4 <sup>[2]</sup>
LD[3]P	39	I	LVDS positive input bit 3 <sup>[2]</sup>
LD[3]N	40	I	LVDS negative input bit 3 <sup>[2]</sup>
LD[2]P	41	I	LVDS positive input bit 2 <sup>[2]</sup>
LD[2]N	42	I	LVDS negative input bit 2 <sup>[2]</sup>
V <sub>DDD</sub>	43	P	digital power supply
LD[1]P	44	I	LVDS positive input bit 1 <sup>[2]</sup>
LD[1]N	45	I	LVDS negative input bit 1 <sup>[2]</sup>
LD[0]P	46	I	LVDS positive input bit 0 <sup>[2]</sup>
LD[0]N	47	I	LVDS negative input bit 0 <sup>[2]</sup>
IO1	48	IO	IO port bit 1
IO0	49	IO	IO port bit 0
SDO	50	O	SPI data output

Table 2. Pin description ...continued

Symbol	Pin	Type <sup>[1]</sup>	Description
SDIO	51	IO	SPI data input/output
SCLK	52	I	SPI clock
SCS_N	53	I	SPI chip select (active LOW)
RESET_N	54	I	general reset (active LOW)
V <sub>DDA(1V8)_D</sub>	55	P	1.8 V analog power supply (DAC core)
IOUTBN	56	O	complementary DAC B output current
IOUTBP	57	O	DAC B output current
V <sub>DDA(1V8)_D</sub>	58	P	1.8 V analog power supply (DAC core)
V <sub>DDA(3V3)</sub>	59	P	3.3 V analog power supply
AUXBP	60	O	auxiliary DAC B output current
AUXBN	61	O	complementary auxiliary DAC B output current
V <sub>DDA(1V8)_P1</sub>	62	P	1.8 V analog power supply (PLL)
VIRES	63	IO	DAC biasing resistor
GAPOUT	64	IO	band gap input/output voltage
V <sub>DDA(1V8)_P2</sub>	65	P	1.8 V analog power supply (PLL)
AUXAN	66	O	complementary auxiliary DAC A output current
AUXAP	67	O	auxiliary DAC A output current
V <sub>DDA(3V3)</sub>	68	P	3.3 V analog power supply
V <sub>DDA1V8_D</sub>	69	P	1.8 V analog power supply (DAC core)
IOUTAP	70	O	DAC A output current
IOUTAN	71	O	complementary DAC A output current
V <sub>DDA(1V8)_D</sub>	72	P	1.8 V analog power supply (DAC core)
GND	H	G	ground (exposed die pad)

[1] P: power supply; G: ground; I: input; O: output.

[2] The LVDS input data bus order can be reversed and each element can be swapped between P and N using dedicated registers (see [Table 60](#)).

## 7. Limiting values

**Table 3. Limiting values**

*In accordance with the Absolute Maximum Rating System (IEC 60134).*

Symbol	Parameter	Conditions	Min	Max	Unit
$V_{DDA(3V3)}$	analog supply voltage (3.3 V)		-0.5	+4.6	V
$V_{DDD}$	digital supply voltage		-0.5	+2.5	V
$V_{DDA(1V8)}$	analog supply voltage (1.8 V)		[1] -0.5	+2.5	V
$V_I$	input voltage	input pins referenced to GND	-0.5	+2.5	V
$V_O$	output voltage	pins IOUTAP, IOUTAN, IOUTBP, IOUTBN, AUXAP, AUXAN, AUXBP and AUXBN referenced to GND	-0.5	+4.6	V
$T_{stg}$	storage temperature		-55	+150	°C
$T_{amb}$	ambient temperature		-40	+85	°C
$T_j$	junction temperature		-40	+125	°C

[1] Connect the analog 1.8 V power supply to pins VDDA1V8\_D, VDDA1V8\_P1, and VDDA1V8\_P2.

## 8. Thermal characteristics

**Table 4. Thermal characteristics**

Symbol	Parameter	Conditions	Typ	Unit
$R_{th(j-a)}$	thermal resistance from junction to ambient		[1] 16.2	K/W
$R_{th(j-c)}$	thermal resistance from junction to case		[1] 6.7	K/W

[1] Value for six-layer board in still air with a minimum of 49 thermal vias.

## 9. Characteristics

**Table 5. Characteristics**

$V_{DDA(1V8)} = 1.8\text{ V}$ ;  $V_{DDD} = 1.8\text{ V}$ ;  $V_{DDA(3V3)} = 3.3\text{ V}$ ; Typical values measured at  $T_{amb} = +25\text{ °C}$ ;  $R_L = 50\ \Omega$ ;  $I_{O(fs)} = 20\text{ mA}$ ; maximum sample rate used; external PLL; no auxiliary DAC; no inverse sinus x/x; no output correction; output load condition defined in [Figure 29](#); output level = 1 V (p-p).

Symbol	Parameter	Conditions	Test [1]	Min	Typ	Max	Unit
$V_{DDA(3V3)}$	analog supply voltage (3.3 V)		C	3.15	3.3	3.45	V
$V_{DDD}$	digital supply voltage		C	1.7	1.8	1.9	V
$V_{DDA(1V8)}$	analog supply voltage (1.8 V)		C	[2] 1.7	1.8	1.9	V
$I_{DDA(3V3)}$	analog supply current (3.3 V)	Auxiliary DAC on	C	51	55	59	mA
$I_{DDD}$	digital supply current (1.8 V)	$f_s = 983.04\text{ 67}$ ; ×4 interpolation; no NCO; MDS off	C	475	525	585	mA
		$f_s = 620\text{ Msps}$ ; ×2 interpolation; NCO on; no MDS	C	400	450	500	mA
$I_{DDA(1V8)}$	analog supply current (1.8 V)	$f_s = 983.04\text{ Msps}$ ; 1 V (p-p)	C	[2] 207	218	230	mA
		$f_s = 620\text{ Msps}$ ; 1 V (p-p)	C	207	218	230	mA
$P_{tot}$	total power dissipation	$f_s = 983.04\text{ Msps}$ ; ×4 interpolation; NCO off; MDS off	C	-	1580	-	mW
		$f_s = 983.04\text{ Msps}$ ; ×4 interpolation; 5-bit NCO; MDS off	C	-	1500	-	mW
		$f_s = 620\text{ Msps}$ ; ×2 interpolation; 5-bit NCO; MDS off	-	-	1370	-	mW
		power-down using SPI register	C	-	63	-	mW

### Clock inputs (pins CLKP, CLKN)

$V_{i(\text{clk})\text{dif}}$	differential clock input voltage	peak-to-peak	C	150	-	1000	mV
$R_i$	input resistance		D	-	200	-	k $\Omega$
$C_i$	input capacitance		D	-	1	-	pF

### Digital inputs (pins LD[15]P to LD[0]P, LD[15]N to LD[0]N, LCKP and LCKN, ALIGNP and ALIGNN)

$V_i$	input voltage	$ V_{\text{gpd}}  < 50\text{ mV}$ [3]	C	825	-	1575	mV
$V_{\text{idth}}$	input differential threshold voltage	$ V_{\text{gpd}}  < 50\text{ mV}$ [3]	C	-100	-	+100	mV
$R_i$	input resistance		D	-	100	-	$\Omega$
$C_i$	input capacitance		D	-	0.8	-	pF
		pins LCKP and LCKN	D	-	0.9	-	pF



**Table 5. Characteristics ...continued**

$V_{DDA(1V8)} = 1.8\text{ V}$ ;  $V_{DDD} = 1.8\text{ V}$ ;  $V_{DDA(3V3)} = 3.3\text{ V}$ ; Typical values measured at  $T_{amb} = +25\text{ °C}$ ;  $R_L = 50\text{ }\Omega$ ;  $I_{O(fs)} = 20\text{ mA}$ ; maximum sample rate used; external PLL; no auxiliary DAC; no inverse sinus x/x; no output correction; output load condition defined in [Figure 29](#); output level = 1 V (p-p).

Symbol	Parameter	Conditions	Test [1]	Min	Typ	Max	Unit
<b>Digital inputs/outputs (pins MDSN, MDSP)</b>							
$V_{o(dif)(p-p)}$	peak-to-peak differential output voltage		C	-	500	-	mV
$C_i$	input capacitance	between GND and pin MDSN or MDSP	D	-	0.6	-	pF
$R_i$	input resistance		D	-	100	-	$\Omega$
$V_i$	input voltage	$ V_{gpdl}  < 50\text{ mV}$ [3]	C	825	-	1575	mV
$V_{idth}$	input differential threshold voltage	$ V_{gpdl}  < 50\text{ mV}$ [3]	C	-100	-	+100	mV
<b>Digital inputs/outputs (pins SDO, SDIO, SCLK, SCS_N, RESET_N, IO0, IO1)</b>							
$V_{IL}$	LOW-level input voltage		C	GND	-	$0.3V_{DDD(1V8)}$	V
$V_{IH}$	HIGH-level input voltage		C	$0.7V_{DDD(1V8)}$	-	$V_{DDD(1V8)}$	V
$V_{OL}$	LOW-level output voltage	pins IO0, IO1, SDO and SDIO	C	GND	-	$0.1V_{DDD(1V8)}$	V
$V_{OH}$	HIGH-level output voltage	pins IO0, IO1, SDO and SDIO	C	$0.9V_{DDD(1V8)}$	-	$V_{DDD(1V8)}$	V
$I_{IL}$	LOW-level input current	maximum VIL	I	-10	-	+10	$\mu\text{A}$
$I_{IH}$	HIGH-level input current	maximum VIL	I	-10	-	+10	$\mu\text{A}$
$C_i$	input capacitance		D	-	2.2	-	pF
<b>Analog outputs (pins IOUTAP, IOUTAN, IOUTBP, IOUTBN)</b>							
$I_{bias}$	bias current	DC current	D	-	2.5	-	mA
$I_{O(fs)}$	full-scale output current	controlled by the analog GAIN registers (see <a href="#">Table 32</a> )	D	8.1	-	34	mA
		default value	D	-	20	-	mA
$V_O$	output voltage	compliance range	D	2.3	-	$V_{DDA(3V3)}$	V
$V_{O(cm)}$	common-mode output voltage	1 V (p-p) DAC output	D	-	3	-	V
		2 V (p-p) DAC output		-	2.8	-	V
$R_o$	output resistance		D	-	250	-	k $\Omega$
$C_o$	output capacitance	between pins OUTAN and OUTBN and pins OUTBN and OUTBP	D	-	5	-	pF
<b>Reference voltage output (pin GAPOUT)</b>							
$V_{O(ref)}$	reference output voltage	$T_{amb} = +25\text{ °C}$	I	-	1.22	-	V

**Table 5. Characteristics ...continued**

$V_{DDA(1V8)} = 1.8\text{ V}$ ;  $V_{DDD} = 1.8\text{ V}$ ;  $V_{DDA(3V3)} = 3.3\text{ V}$ ; Typical values measured at  $T_{amb} = +25\text{ °C}$ ;  $R_L = 50\ \Omega$ ;  $I_{O(fs)} = 20\text{ mA}$ ; maximum sample rate used; external PLL; no auxiliary DAC; no inverse sinus x/x; no output correction; output load condition defined in [Figure 29](#); output level = 1 V (p-p).

Symbol	Parameter	Conditions	Test <a href="#">[1]</a>	Min	Typ	Max	Unit
$I_{O(ref)}$	reference output current	1.25 V external voltage	D	-	40	-	$\mu\text{A}$
<b>Analog auxiliary outputs (pins AUXAP, AUXAN, AUXBP and AUXBN)</b>							
$I_{O(fs)}$	full-scale output current	auxiliary DAC A; differential outputs	I	-	3.1	-	mA
		auxiliary DAC B; differential outputs	I	-	3.1	-	mA
$V_{O(aux)}$	auxiliary output voltage	compliance range	D	0	-	2.3	V
<b>LVDS input timing</b>							
$f_{data}$	data rate	$f_{s(max)}$ specification must be respected ( $f_s = f_{data} \times \text{interpolation factor}$ )	C	-	-	370	MHz
$t_{sk(clk-D)}$	skew time from clock to data input	$f_{DATA} = 184.32\text{ Mhz}$	C	800	-	830	ps
		$f_{DATA} = 245.76\text{ MHz}$	C	500	-	675	ps
		$f_{DATA} = 307.2\text{ MHz}$	C	300	-	520	ps
		$f_{DATA} = 368.64\text{ MHz}$	C	150	-	500	ps
$t_{su}$	set-up time	manual tuning mode (see <a href="#">Figure 16</a> ); depends on LDCLK_DEL[3:0]					
		0000	C	-300	-	-	ps
		0001	C	-365	-	-	ps
		0010	C	-440	-	-	ps
		0011	C	-520	-	-	ps
		0100	C	-590	-	-	ps
		0101	C	-675	-	-	ps
		0110	C	-750	-	-	ps
		0111	C	-830	-	-	ps
		1000	C	-845	-	-	ps
		1001	C	-845	-	-	ps
		1010	C	-1000	-	-	ps
		1011	C	-1100	-	-	ps
		1100	C	-1220	-	-	ps
		1101	C	-1290	-	-	ps
		1110	C	-1360	-	-	ps
1111	C	-1450	-	-	ps		

**Table 5. Characteristics ...continued**

$V_{DDA(1V8)} = 1.8\text{ V}$ ;  $V_{DDD} = 1.8\text{ V}$ ;  $V_{DDA(3V3)} = 3.3\text{ V}$ ; Typical values measured at  $T_{amb} = +25\text{ °C}$ ;  $R_L = 50\ \Omega$ ;  $I_{O(fs)} = 20\text{ mA}$ ; maximum sample rate used; external PLL; no auxiliary DAC; no inverse sinus x/x; no output correction; output load condition defined in [Figure 29](#); output level = 1 V (p-p).

Symbol	Parameter	Conditions	Test <a href="#">[1]</a>	Min	Typ	Max	Unit
$t_{hold}$	hold time	manual tuning mode (see <a href="#">Figure 15</a> ); depends on LDCLK_DEL[3:0]:					
		0000	C	790	-	-	ps
		0001	C	870	-	-	ps
		0010	C	950	-	-	ps
		0011	C	1055	-	-	ps
		0100	C	1140	-	-	ps
		0101	C	1230	-	-	ps
		0110	C	1360	-	-	ps
		0111	C	1460	-	-	ps
		1000	C	1900	-	-	ps
		1001	C	2075	-	-	ps
		1010	C	2250	-	-	ps
		1011	C	2400	-	-	ps
		1100	C	2560	-	-	ps
		1101	C	2740	-	-	ps
1110	C	2900	-	-	ps		
1111	C	3000	-	-	ps		
<b>DAC output timing</b>							
$f_{s(max)}$	sampling rate		C	1000	-	-	Msp/s
$t_s$	settling time	to $\pm 0.5\text{ LSB}$	D	-	20	-	ns
<b>Internal PLL timing</b>							
$f_s$	sampling rate		D	50	-	1000	Msp/s
<b>40-bit NCO frequency range; <math>f_s = 1000\text{ Msp/s}</math></b>							
$f_{NCO}$	NCO frequency	two's complement coding					
		register value = 8000000000h	D	-	-500	-	MHz
		register value = FFFFFFFFh	D	-	-0.9095	-	mHz
		register value = 0000000000h	D	-	0	-	Hz
		register value = 000000001h	D	-	+0.9095	-	mHz
		register value = 7FFFFFFFh	D	-	+499.99909	-	MHz
$f_{step}$	step frequency		D	-	0.9095	-	mHz

**Table 5. Characteristics ...continued**

$V_{DDA(1V8)} = 1.8\text{ V}$ ;  $V_{DDD} = 1.8\text{ V}$ ;  $V_{DDA(3V3)} = 3.3\text{ V}$ ; Typical values measured at  $T_{amb} = +25\text{ °C}$ ;  $R_L = 50\ \Omega$ ;  $I_{O(fs)} = 20\text{ mA}$ ; maximum sample rate used; external PLL; no auxiliary DAC; no inverse sinus x/x; no output correction; output load condition defined in [Figure 29](#); output level = 1 V (p-p).

Symbol	Parameter	Conditions	Test <a href="#">[1]</a>	Min	Typ	Max	Unit
<b>Low-power NCO frequency range; <math>f_s = 1000\text{ MHz}</math></b>							
$f_{NCO}$	NCO frequency	two's complement coding					
		register value = F800000000h	D	-	-500	-	MHz
		register value = F800000000h	D	-	-31.25	-	MHz
		register value = 0000000000h	D	-	0	-	Hz
		register value = 0800000000h	D	-	+31.25	-	MHz
		register value = 7FFFFFFFh	D	-	+468.75	-	MHz
$f_{step}$	step frequency		D	-	31.25	-	MHz
<b>Dynamic performance</b>							
SFDR	spurious-free dynamic range	$f_{data} = 245.76\text{ MHz}$ ; $f_s = 983.04\text{ Msps}$ ; $BW = f_s / 2$					
		$f_o = 20\text{ MHz at } -1\text{ dBFS}$	I	-	78	-	dBc
		$f_{data} = 184.32\text{ MHz}$ ; $f_s = 737.28\text{ Msps}$ ; $BW = f_s / 2$					
		$f_o = 20\text{ MHz at } -1\text{ dBFS}$		-	78	-	dBc
SFDR <sub>RBW</sub>	restricted bandwidth spurious-free dynamic range	$f_{data} = 245.76\text{ MHz}$ ; $f_s = 983.04\text{ Msps}$ ; $f_o = 150\text{ MHz}$		-		-	dBc
		$BW = 100\text{ MHz}$		-	78	-	dBc
		$BW = 180\text{ MHz}$		-	78	-	dBc
IMD3	third-order intermodulation distortion	$f_{data} = 245.76\text{ MHz}$ ; $f_s = 983.04\text{ Msps}$ ; $f_{o1} = 20\text{ MHz}$ ; $f_{o2} = 21\text{ MHz}$ ; $\times 4$ interpolation; output level = -1 dBFS	C	-	75	-	dBc
		$f_{data} = 245.76\text{ MHz}$ ; $f_s = 983.04\text{ Msps}$ ; $f_{o1} = 152\text{ MHz}$ ; $f_{o2} = 155.1\text{ MHz}$ ; $\times 4$ interpolation; output level = -1 dBFS	I	-	75	-	dBc

**Table 5. Characteristics ...continued**

$V_{DDA(1V8)} = 1.8\text{ V}$ ;  $V_{DDD} = 1.8\text{ V}$ ;  $V_{DDA(3V3)} = 3.3\text{ V}$ ; Typical values measured at  $T_{amb} = +25\text{ °C}$ ;  $R_L = 50\ \Omega$ ;  $I_{O(f_s)} = 20\text{ mA}$ ; maximum sample rate used; external PLL; no auxiliary DAC; no inverse sinus x/x; no output correction; output load condition defined in [Figure 29](#); output level = 1 V (p-p).

Symbol	Parameter	Conditions	Test [1]	Min	Typ	Max	Unit
ACPR	adjacent channel power ratio	WCDMA pattern; $f_s = 983.04\text{ Msps}$ ; $\times 4$ interpolation; $f_{NCO} = 153.6\text{ MHz}$					
		1 carrier; BW = 5 MHz	C	-	73	-	dBc
		2 carriers; BW = 10 MHz	C	-	70	-	dBc
		4 carriers; BW = 20 MHz	C	-	68	-	dBc
$\alpha_{\text{isol(ch-ch)}}$	isolation between channels	$f_s = 1228.8\text{ Msps}$ ; $\times 4$ interpolation; $f_{\text{out}} = 10\text{ MHz}$ ; NCO = off; level = 0.1 dBFS; both DAC channels enabled	C	-	110	-	dBc
		$f_s = 1228.8\text{ Msps}$ ; $\times 4$ interpolation; $f_{\text{out}} = 83\text{ MHz}$ ; NCO = off; level = 0.1 dBFS; both DAC channels enabled	C	-	95	-	dBc
		$f_s = 1228.8\text{ Msps}$ ; $\times 4$ interpolation; $f_{\text{out}} = 210\text{ MHz}$ ; NCO = on; level = 0.1 dBFS; one DAC channel enabled; one DAC channel disabled	C	-	81	-	dBc
NSD	noise spectral density	$f_s = 983.04\text{ Msps}$ ; $\times 4$ interpolation; $f_o = 20\text{ MHz}$ at -1 dBFS	D	-	-158	-	dBm/Hz
		$f_s = 983.04\text{ Msps}$ ; $\times 4$ interpolation; $f_o = 153.6\text{ MHz}$ at -1 dBFS	D	-	-155	-	dBm/Hz

[1] D = guaranteed by design; C = guaranteed by characterization; I = 100 % industrially tested.

[2] Connect  $V_{DDA(1V8)_D}$ ,  $V_{DDA(1V8)_P1}$  and  $V_{DDA(1V8)_P2}$  to the same 1.8 V analog power supply. Use dedicated filters for the three power pins.

[3]  $|V_{\text{gpd}}|$  represents the ground potential difference voltage. This voltage is the result of current flowing through the finite resistance and the inductance between the receiver and the driver circuit ground voltages.

## 10. Application information

### 10.1 General description

The DAC1617D1G0 is a dual 16-bit DAC operating up to 1000 Msps. Each DAC consists of a segmented architecture, comprising a 6-bit thermometer subDAC and a 10-bit binary weighted subDAC.

A maximum input LVDS DDR data rate of up to 370 MHz and a maximum output sampling rate of 1000 Msps ensure more flexibility for wide bandwidth and multi-carrier systems. The internal 40-bit NCO of the DAC1617D1G0 simplifies the frequency selection of the system. The DAC1617D1G0 provides x2, x4 or x8 interpolation filters that are useful for removing the undesired images.

Each DAC generates two complementary current outputs on pins IOUTAP and IOUTAN and pins IOUTBP and IOUTBN. These outputs provide a full-scale output current ( $I_{O(fs)}$ ) of up to 34 mA. An internal reference is available for the reference current which is externally adjustable using pin VIRES.

High resolution internal gain, phase and offset control provide outstanding image and Local Oscillator (LO) signal rejection at the system analog modulator output.

Multiple device synchronization enables synchronization of the outputs of multiple DAC devices. MDS guarantees a maximum skew of one output clock period between several devices.

All functions can be set using an SPI interface.

### 10.2 Serial Peripheral Interface (SPI)

#### 10.2.1 Protocol description

The DAC1617D1G0 serial interface is a synchronous serial communication port ensures easy interface with many industry microprocessors. It provides access to the registers that define the operating modes of the chip in both write and read mode.

This interface can be configured as a 3-wire type (pin SDIO as bidirectional pin) or 4-wire type (pins SDIO and SDO as unidirectional pins, input and output port, respectively). In both configurations, SCLK acts as the serial clock and SCS\_N as the serial chip select.

[Figure 3](#) shows the SPI protocol. An SCS\_N signal follows each read/write operation. A LOW assertion enables it to drive the chip with 2 bytes to 5 bytes, depending on the content of the instruction byte (see [Table 7](#)).

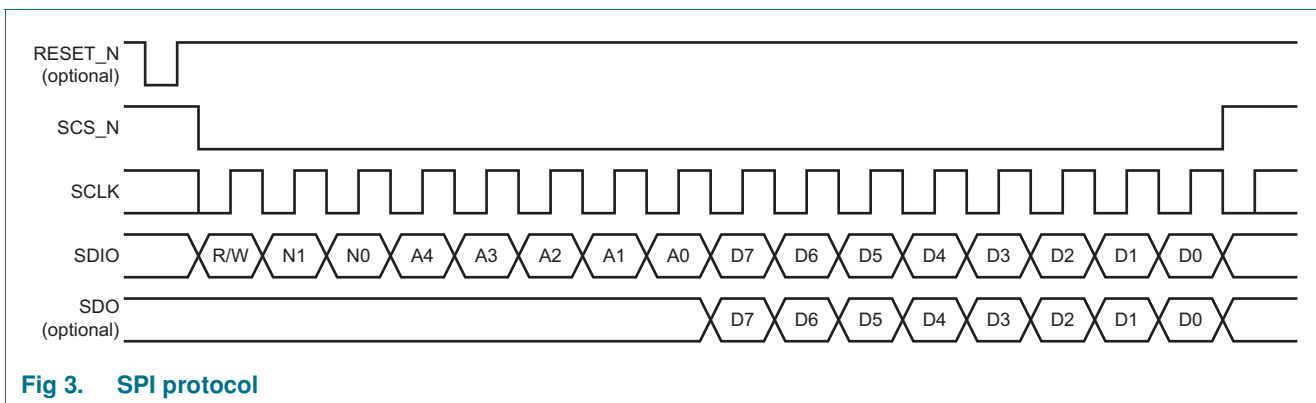

**Fig 3. SPI protocol**

R/W indicates the mode access (see [Table 6](#))

**Table 6. Read or Write mode access description**

R/W	Description
0	Write mode operation
1	Read mode operation

[Table 7](#) shows the number of bytes to be transferred. N1 and N0 indicate the number of bytes transferred after the instruction byte.

**Table 7. Number of bytes transferred**

N1	N0	Number of bytes transferred
0	0	1 byte
0	1	2 bytes
1	0	3 bytes
1	1	4 bytes

A[4:0] indicates which register is being addressed. If a multiple transfer occurs, this address concerns the first register. The other registers follow directly in a decreasing order (see [Table 21](#), [Table 35](#) and [Table 53](#)).

The DAC1617D1G0 incorporates more than the 32 SPI registers allowed by the address value A[4:0]. It uses three SPI register pages (page\_00, page\_01, and page\_0A), each containing 32 registers. The 32<sup>nd</sup> register of each page indicates which page is currently addressed (00h, 01h or 0Ah).

### 10.2.2 SPI timing description

The SPI interface can operate at a frequency up to 25 MHz. The SPI timings are shown in [Figure 4](#).

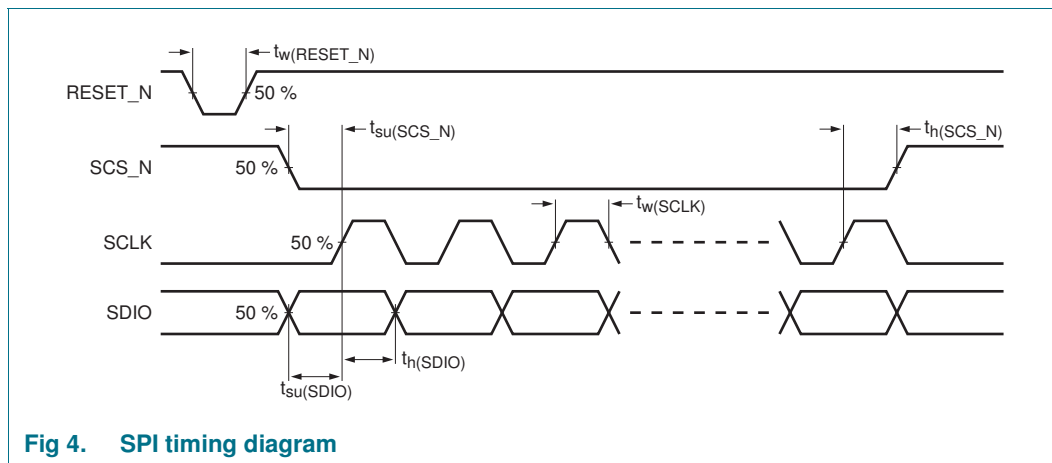

Fig 4. SPI timing diagram

The SPI timing characteristics are given in [Table 8](#).

Table 8. SPI timing characteristics

Symbol	Parameter	Min	Typ	Max	Unit
$f_{\text{SCLK}}$	SCLK frequency	-	-	25	MHz
$t_w(\text{SCLK})$	SCLK pulse width	30	-	-	ns
$t_{su}(\text{SCS\_N})$	SCS_N set-up time	20	-	-	ns
$t_h(\text{SCS\_N})$	SCS_N hold time	20	-	-	ns
$t_{su}(\text{SDIO})$	SDIO set-up time	10	-	-	ns
$t_h(\text{SDIO})$	SDIO hold time	5	-	-	ns
$t_w(\text{RESET\_N})$	RESET_N pulse width	30	-	-	ns

### 10.3 Power-on sequence

There are three steps for the power-on sequence (see [Figure 5](#)):

1. The board is power-on. At the turn-on time, all DAC1617D1G0 supplies have reached their specification ranges.
2. At least 1  $\mu\text{s}$  after the turn-on time pin RESET\_N must be released.
3. When the DAC clock and LVDS clock are stable, the SPI configuration is sent to the DAC1617D1G0. Writing 0 in bits RST\_DCLK and RST\_LCLK of the register MAIN\_CNTRL (see [Table 54](#)) starts the automatic calibration. 30  $\mu\text{s}$  after this calibration, the DAC1617D1G0 is operational.



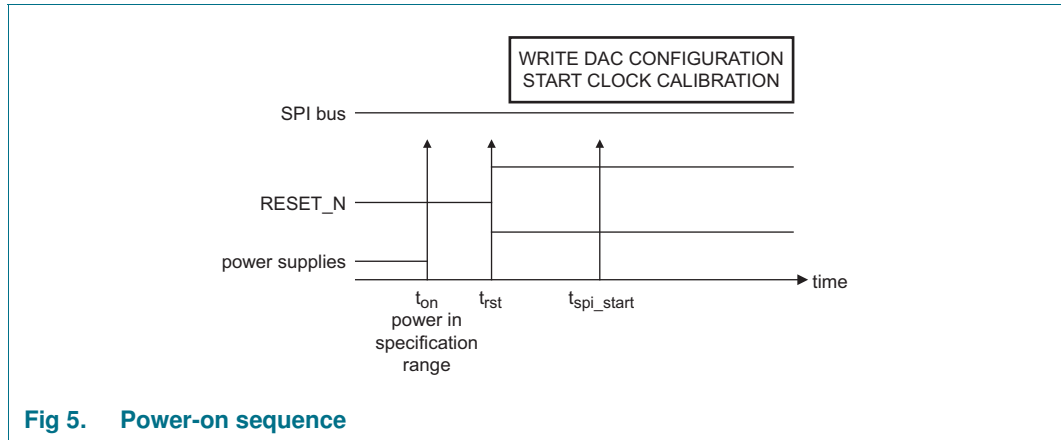

Fig 5. Power-on sequence

### 10.4 LVDS Data Input Format (DIF) block

The Data Input Formatting (DIF) block captures and resynchronizes data on the LVDS bus with its own LCLKP/LCLKN clock. Each LVDS input buffer has an internal resistance of 100  $\Omega$ , so an external resistor is not required. The DIF block includes two subblocks:

- LVDS receiver:**  
 Provides high flexibility for the LVDS interface, especially for the PCB layout and the control of the input port polarity and the input port mapping.
- Data format block:**  
 Enables the adaptation, which ensures the support of several data encoding modes.

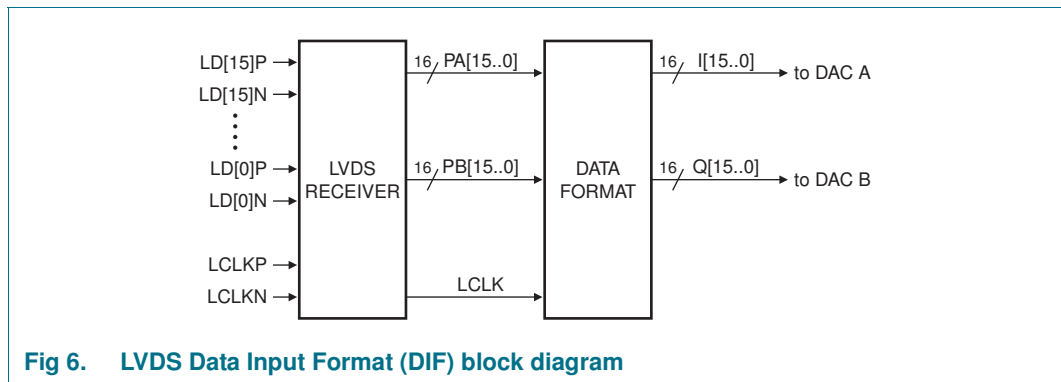

Fig 6. LVDS Data Input Format (DIF) block diagram

#### 10.4.1 Input port polarity

The polarity of each individual LVDS input (LD[15]P to LD[0]P and LD[15]N to LD[0]N) can be changed. This ensures a much easier PCB layout design. The input polarity is controlled with bits LD\_POL[15:0] (see [Table 59](#)).

#### 10.4.2 Input port mapping

Inverting the order of the LSB and the MSB of the LVDS bus using bit WORD\_SWAP in register LD\_CNTRL (see [Table 60](#)) also simplifies the design of the PCB (see [Table 9](#)).

**Table 9. Input LVDS bus swapping**

Internal LVDS bus	External LVDS bus (WORD_SWAP = 0)	External LVDS bus (WORD_SWAP = 1)
LDI[15]P,N	LD[15]P,N	LD[0]P,N
LDI[14]P,N	LD[14]P,N	LD[1]P,N
LDI[13]P,N	LD[13]P,N	LD[2]P,N
LDI[12]P,N	LD[12]P,N	LD[3]P,N
LDI[11]P,N	LD[11]P,N	LD[4]P,N
LDI[10]P,N	LD[10]P,N	LD[5]P,N
LDI[9]P,N	LD[9]P,N	LD[6]P,N
LDI[8]P,N	LD[8]P,N	LD[7]P,N
LDI[7]P,N	LD[7]P,N	LD[8]P,N
LDI[6]P,N	LD[6]P,N	LD[9]P,N
LDI[5]P,N	LD[5]P,N	LD[10]P,N
LDI[4]P,N	LD[4]P,N	LD[11]P,N
LDI[3]P,N	LD[3]P,N	LD[12]P,N
LDI[2]P,N	LD[2]P,N	LD[13]P,N
LDI[1]P,N	LD[1]P,N	LD[14]P,N
LDI[0]P,N	LD[0]P,N	LD[15]P,N

**10.4.3 Input port swapping**

The LVDS DDR receiver block internally maps the incoming LVDS data bus into two buses with a single data rate (Figure 7).

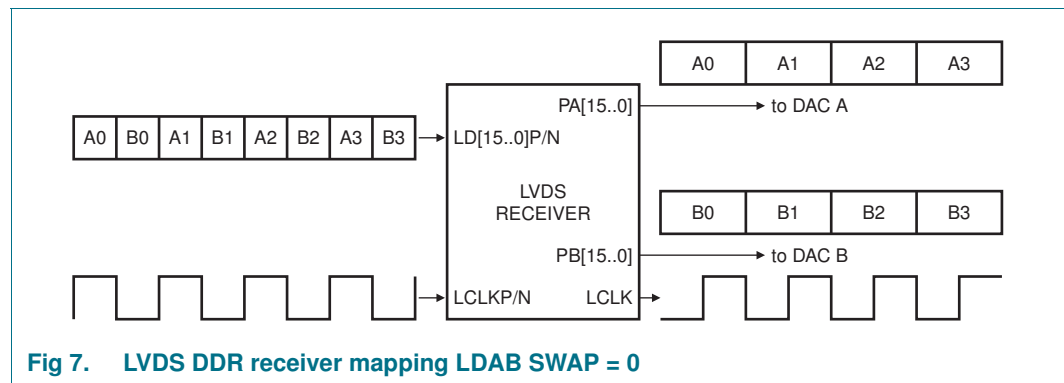

These two buses can be swapped internally using bit LDAB\_SWAP of register LD\_CNTRL (see Table 60 and Figure 8).

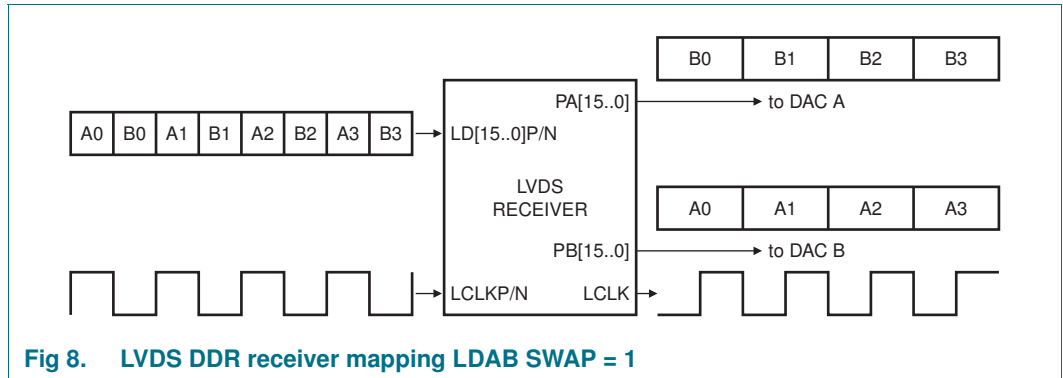

Fig 8. LVDS DDR receiver mapping LDAB SWAP = 1

10.4.4 Input port formatting

The LVDS DDR input bus multiplexes two 16-bit streams. The LVDS receiver block demultiplexes these two streams.

The two streams can carry two data formats:

- Folded
- Interleaved

The data format block is in charge of the data format adaptation (see [Figure 9](#)).

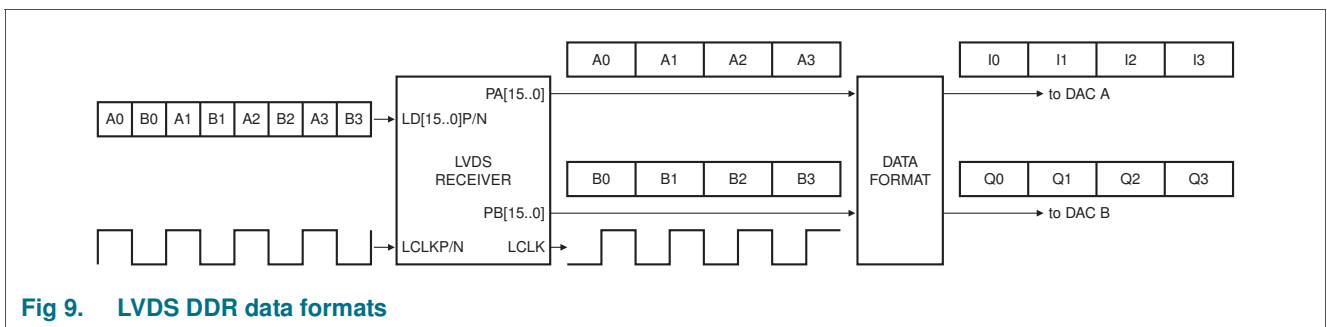

Fig 9. LVDS DDR data formats

The DAC1617D1G0 can correctly decode the input stream using bit IQ\_FORMAT of register LD\_CNTRL (see [Table 60](#)), because it can determine which format is used on the LVDS DDR bus.

[Table 10](#) shows the format mapping between the LVDS input data and the data sent to the two DAC channels depending on the data format selected.

Table 10. Folded and interleaved format mapping

Data format	Data bit mapping
interleaved format (IQ_FORMAT = 1)	In[15..0] = An[15..0]; Qn[15..0] = Bn[15..0]
folded format (IQ_FORMAT = 0)	In[15..8] = An[15..8]; In[7..0] = Bn[15..8] Qn[15..8] = An[7..0]; Qn[7..0] = Bn[7..0]

### 10.4.5 Data parity/data enable

The ALIGN pins can be used in several ways:

- As datastream start flag for Multiple Devices Synchronization (see [Section 10.13](#)).
- As LVDS data enable which can be used to insert a DC level into the datastream. The SEL\_EN bits in register LD\_CNTRL (see [Table 60](#)) enable the programming of this mode. The DC level for both channels is selected using registers I\_DC\_LVL and Q\_DC\_LVL (see [Table 62](#)).
- As parity bit for the LD[15:0] to detect disruptions at the LVDS-input port bit PARITYC in register LD\_CNTRL (see [Table 60](#)) enabling the control of this mode. A Parity error can generate an interrupt (INTR) reported on either IO0 or IO1 pin

## 10.5 Interrupt controller

The DAC1617D1G0 incorporates an interrupt controller that makes notifying a host-controller in case of an internal event. The INTR-signal can be made available on one of the IO pins. The polarity on the IO pins is programmable.

The internal event that must be tracked and generates an interrupt can be selected using the INTR\_EN register (see [Table 45](#)). Two types of interrupt sources are considered:

- The ready-indicators (MAQ\_RDY\_B, MAQ\_RDY\_A, AUTO\_CAL\_RDY, and AUTO\_DL\_RDY; register INTR\_FLAGS; see [Table 47](#)) notify the host-interface that the corresponding process (invoked by the host interface) has been finalized
- The error flags indicate that a failure has been detected. For example, on the LVDS-interface it is possible to check for parity errors and/or to monitor if the internal timing of the LVDS clock delay has changed since the calibration. Errors like these can result in critical timings within the Clock Domain Interface (CDI) which transfers the data from the LCLK to the DCLK domain

The selected event that has invoked the interrupt can be determined using the INTR\_FLAGS register (see [Table 47](#)). The flags and the INTR signal are reinitialized by setting the INTR\_CLEAR control bit in register INTR\_CTRL (see [Table 45](#)).

## 10.6 General-purpose IO pins

The DAC1617D1G0 provides two general-purpose pins, IO0 and IO1. These pins can be used to observe the interrupt signal (INTR) or other internal signals (internal clocks, LVDS data, etc.). These pins can also be used as generic outputs to control external devices.

The internal signals that must be observed on these pins are selected using registers IO\_MUX0, IO\_MUX1, and IO\_MUX2 (see [Table 63](#) and [Table 64](#)).

## 10.7 Input clock

The DAC1617D1G0 operates with two clocks, one for the LVDS DDR interface and one for the DAC core.

### 10.7.1 LVDS DDR clock

The LVDS DDR clock can be interfaced as shown in [Figure 10](#) because the clock buffer contains a 100  $\Omega$  internal resistor.

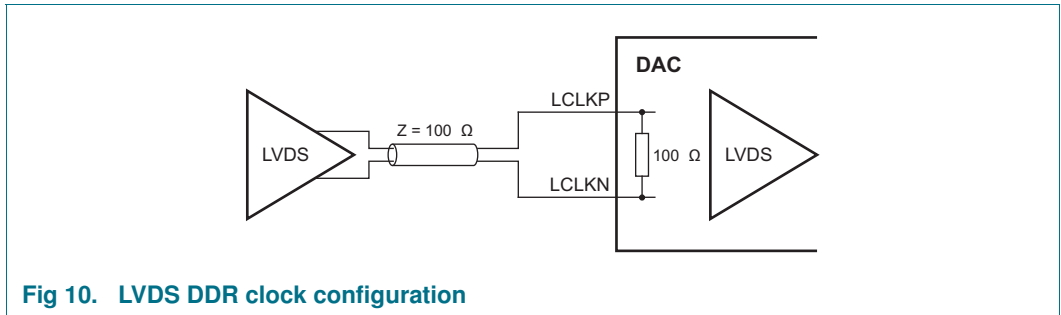

Fig 10. LVDS DDR clock configuration

10.7.2 DAC core clock

The DAC core clock can achieve a frequency of up to 1 Gsps. It includes internal biasing to support both AC-coupling and DC-coupling. The clock can be easily connected to any LVDS, CML or PECL clock sources.

Depending on the interface selected, the hardware configuration varies (see [Figure 11](#) to [Figure 13](#)).

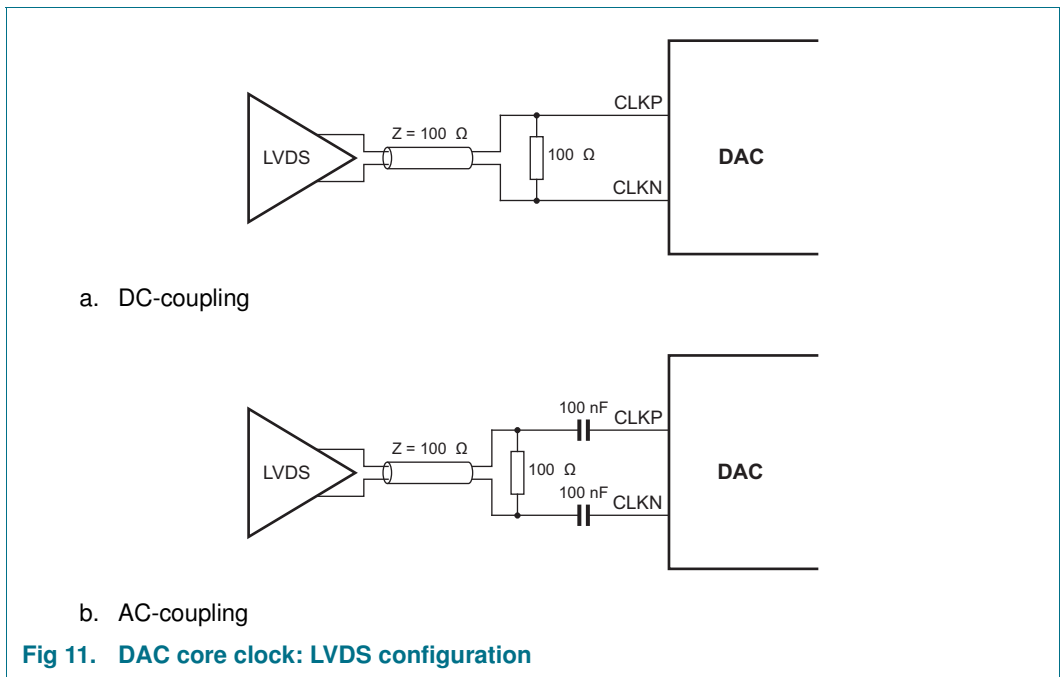

Fig 11. DAC core clock: LVDS configuration

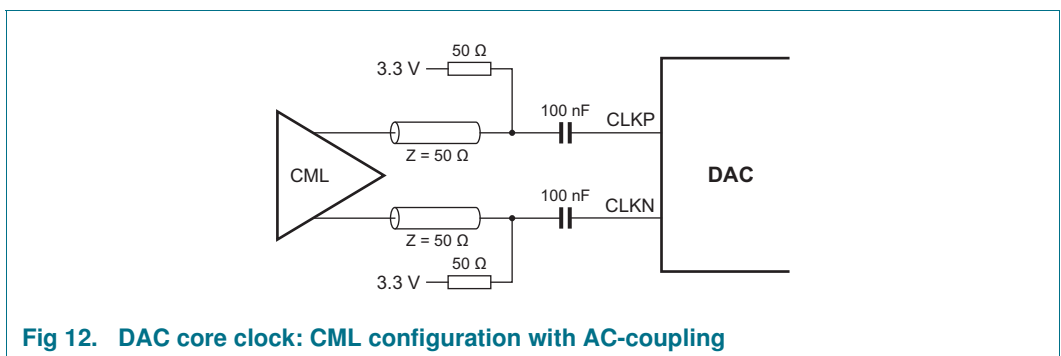

Fig 12. DAC core clock: CML configuration with AC-coupling

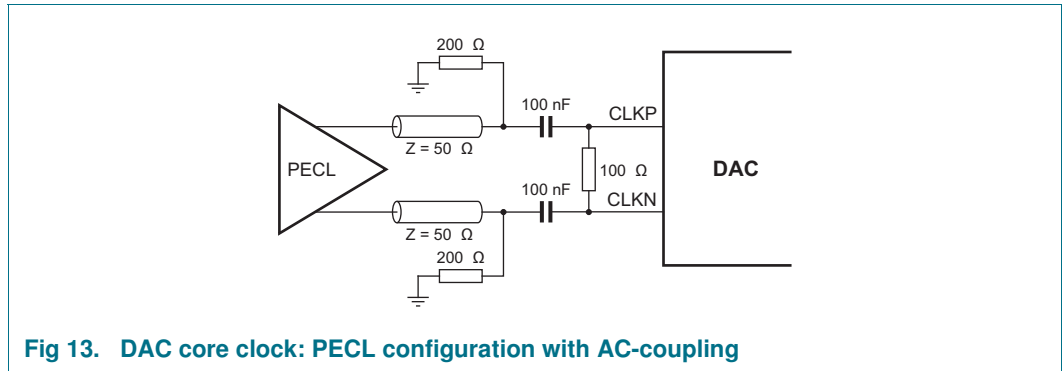

Fig 13. DAC core clock: PECL configuration with AC-coupling

### 10.8 Timing

The DAC1617D1G0 can operate at an update rate ( $f_s$ ) of up to 1 Gsps and with an input data rate ( $f_{data}$ ) of up to 370 MHz.

The sampling position of the LVDS data can be tuned using a 16-step compensation delay clock. An internal clock is generated to define the exact sampling position of the LVDS data (see Figure 14, signals LDCLKPcp and LDCLKNcp) which depends on the compensation delay.

Figure 14 shows how the compensation delay helps to recover the LVDS DDR data on both the A and B paths.

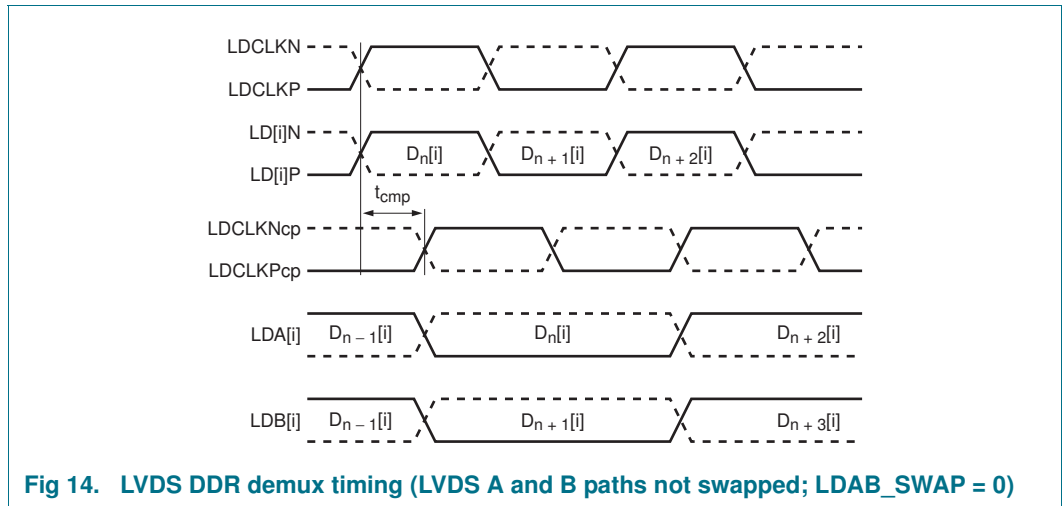
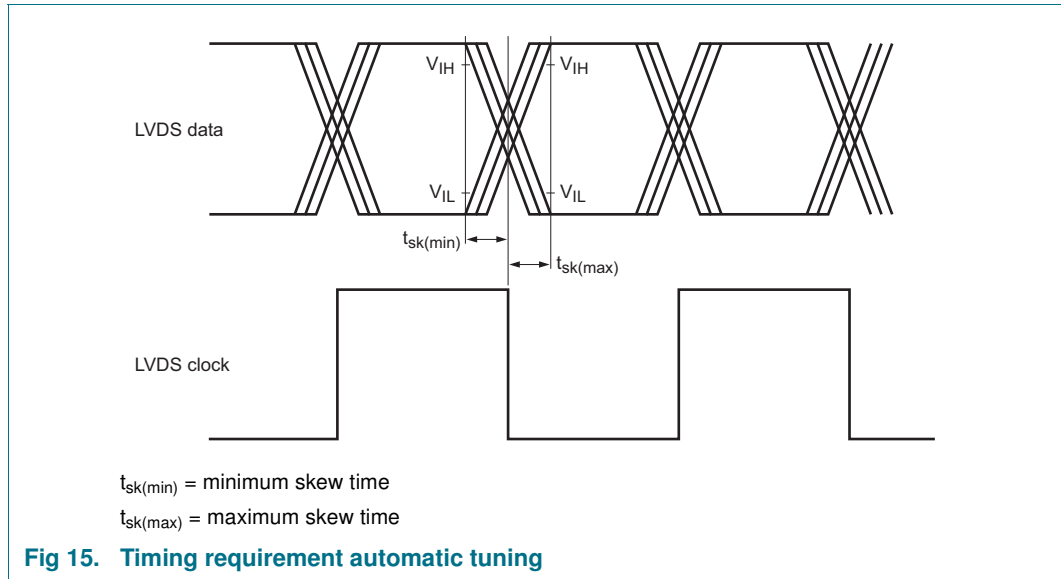

Fig 14. LVDS DDR demux timing (LVDS A and B paths not swapped; LDAB\_SWAP = 0)

The compensation delay time ( $t_{cmp}$  in Figure 14) can be tuned automatically or manually. Bit CAL\_CNTRL of the MAIN\_CNTRL register (see Table 54) enables the switching between automatic tuning and manual tuning.

In Automatic tuning mode, the external LVDS data and clock signals are generated using the same reference clock (inside the FPGA). The LDCLK clock is similar to a data bit that toggles each time (the rising edge and falling edge of the LDCLK and LVDS data occur at the same time). In automatic tuning, the internal compensation delay time ( $t_{cmp}$ ) is defined automatically to compensate the internal DAC1617D1G0 delay time optimally.

The timing requirement in automatic tuning mode is defined in Figure 15 and in Table 5.



Use manual tuning mode if the LVDS data and the LDCLK clock signals provided to the DAC1617D1G0 device have a systematic delay. The compensation delay time can be adjusted to compensate for the systematic delay. The compensation delay time ( $t_{cmp}$  in [Figure 14](#)), can be defined using bits LDCLK\_DEL[3:0] of register MAN\_LDCLKDEL (see [Table 55](#)).

The timing requirement in manual tuning mode is defined in [Figure 16](#) and in [Table 5](#).

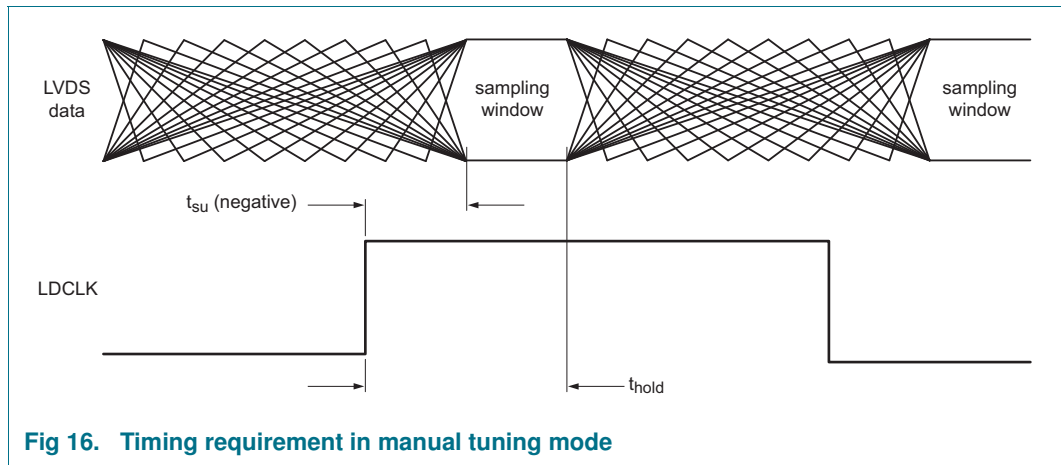

### 10.9 Operating modes

The DAC1617D1G0 requires two differential clocks:

- The LVDS clock (LDCLKP, LDCLKN) for the LVDS DDR interface
- The data clock (CLKP, CLKN) for the internal PLL and the dual DAC core

In Normal mode, provide both the DAC clock and the LVDS clock to the DAC1617D1G0. Align the ratio frequency between these two clocks needs with selected x2, x4 or x8 interpolating filters. The clocks provided to the DAC1617D1G0 must respect the LVDS input timing and the DAC output timing specifications as defined in [Table 5](#).

In PLL mode, provide the LVDS clock to pins LDCLKP/LDCLKN and pins CLKP/CLKN. Depending on selected interpolation filter, the internal PLL can be set to generate the right DAC core clock frequency internally. The clocks provided to the DAC1617D1G0 pins must respect the LVDS input timing and the DAC output timing specifications as defined in [Table 5](#). The PLL settings must also respect the maximum sampling rate of the PLL (see the sampling rate ( $f_s$ ) in subsection Internal PLL timing of [Table 5](#)).

The main function of the Clock Domain Interface (CDI) is to resynchronize the input data streams to the internal clock the digital processing uses. The CDI also performs the required reformatting of the input datastreams. Set PLL, CDI, and the interpolation filters, which depend on the targeted application accordingly. [Section 10.9.1](#) (x2), [Section 10.9.2](#) (x4), and [Section 10.9.3](#) (x8) explain how to set the DAC1617D1G0 to support the different upsampling modes.

### 10.9.1 CDI mode 0 (x2 interpolation)

CDI mode 0 (x2 interpolation) is required when the value of the LVDS DDR clock is twice the internal maximum CDI frequency. [Table 11](#) shows examples of applications using an internal PLL or an external clock for the DAC core.

**Table 11. CDI mode 0: operating modes examples**

LVDS DDR rate (MHz)	I rate; Q rate (Msps)	CDI mode <sup>[1]</sup>	FIR mode <sup>[2]</sup>	SSBM rate <sup>[3]</sup> (Msps)	DAC rate (Msps)	PLL configuration		
						DAC input clock <sup>[4]</sup> (MHz)	PLL status <sup>[5]</sup>	PLL divider <sup>[6]</sup>
320	320	0	x2	640	640	320	enabled	2
320	320	0	x2	640	640	640	disabled	n.a.

[1] Bits CDI\_MODE[1:0] of register MISC\_CNTRL (see [Table 61](#)).

[2] Bits INTERPOLATION[1:0] of register TXCFG (see [Table 23](#)).

[3] If a Single Sideband Modulator (SSBM) is used, see bits NCO\_ON and MODULATION[2:0] of register TXCFG (see [Table 23](#)).

[4] Pins CLKP and CLKN (see [Figure 2](#)).

[5] Bit PLL\_PD of register PLLCFG (see [Table 24](#)).

[6] Bits PLL\_DIV[1:0] of register PLLCFG (see [Table 24](#)).



### 10.9.2 CDI mode 1 (x4 interpolation)

CDI mode 1 (x4 interpolation) is required when the values of the LVDS DDR clock and the internal CDI frequency are equal. [Table 12](#) shows examples of applications using an internal PLL or an external clock for the DAC core.

**Table 12. CDI mode 1: operating modes examples**

LVDS DDR rate (MHz)	I rate; Q rate (Msps)	CDI mode <sup>[1]</sup>	FIR mode <sup>[2]</sup>	SSBM rate <sup>[3]</sup> (Msps)	DAC rate (Msps)	PLL configuration		
						DAC input clock <sup>[4]</sup> (MHz)	PLL status <sup>[5]</sup>	PLL divider <sup>[6]</sup>
250	250	1	x4	1000	1000	250	enabled	4
250	250	1	x4	1000	1000	1000	disabled	n.a.

[1] Bits CDI\_MODE[1:0] of register MISC\_CNTRL (see [Table 61](#)).

[2] Bits INTERPOLATION[1:0] of register TXCFG (see [Table 23](#)).

[3] If SSBM is used, see bits NCO\_ON and MODULATION[2:0] of register TXCFG (see [Table 23](#)).

[4] Pins CLKP and CLKN (see [Figure 2](#)).

[5] Bit PLL\_PD of register PLLCFG (see [Table 24](#)).

[6] Bits PLL\_DIV[1:0] of register PLLCFG (see [Table 24](#)).

### 10.9.3 CDI mode 2 (x8 interpolation)

CDI mode 2 (x8 interpolation) is required when the LVDS DDR clock is half the maximum CDI frequency or less. [Table 13](#) shows examples of applications using an internal PLL or an external clock for the DAC core.

**Table 13. CDI mode 2: operating modes examples**

LVDS DDR rate (MHz)	I rate; Q rate (Msps)	CDI mode <sup>[1]</sup>	FIR mode <sup>[2]</sup>	SSBM rate <sup>[3]</sup> (Msps)	DAC rate (Msps)	PLL configuration		
						DAC input clock <sup>[4]</sup> (MHz)	PLL status <sup>[5]</sup>	PLL divider <sup>[6]</sup>
125	125	2	x8	1000	1000	125	enabled	4
125	125	2	x8	1000	1000	1000	disabled	n.a.

[1] Bits CDI\_MODE[1:0] of register MISC\_CNTRL (see [Table 61](#)).

[2] Bits INTERPOLATION[1:0] of register TXCFG (see [Table 23](#)).

[3] If SSBM is used, see bits NCO\_ON and MODULATION[2:0] of register TXCFG (see [Table 23](#)).

[4] Pins CLKP and CLKN (see [Figure 2](#)).

[5] Bit PLL\_PD of register PLLCFG (see [Table 24](#)).

[6] Bits PLL\_DIV[1:0] of register PLLCFG (see [Table 24](#)).

**10.10 FIR filters**

The DAC1617D1G0 integrates three selectable Finite Impulse Response (FIR) filters which enable the use of the device with x2, x4 or x8 interpolation rates. All three interpolation FIR filters have a stop-band attenuation of at least 80 dBc and a pass-band ripple of less than 0.0005 dB. [Table 14](#) shows the coefficients of the interpolation filters.

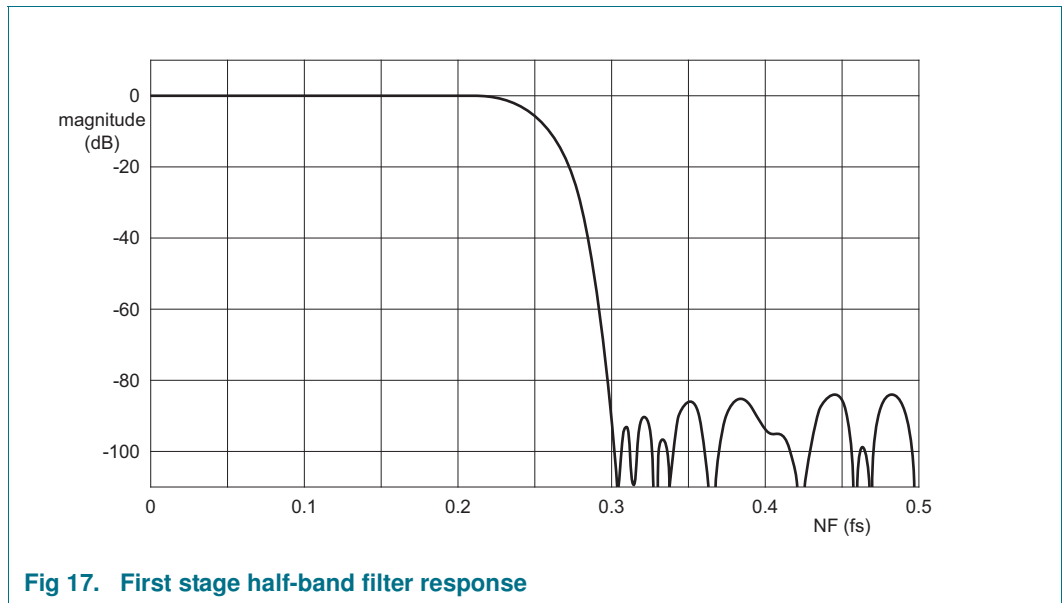

**Fig 17. First stage half-band filter response**

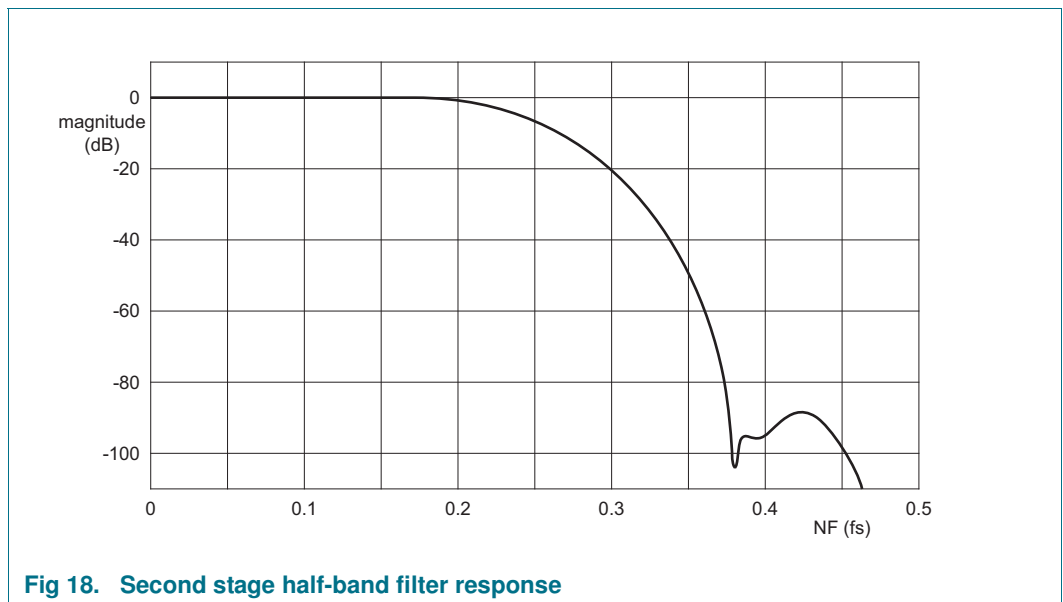

**Fig 18. Second stage half-band filter response**

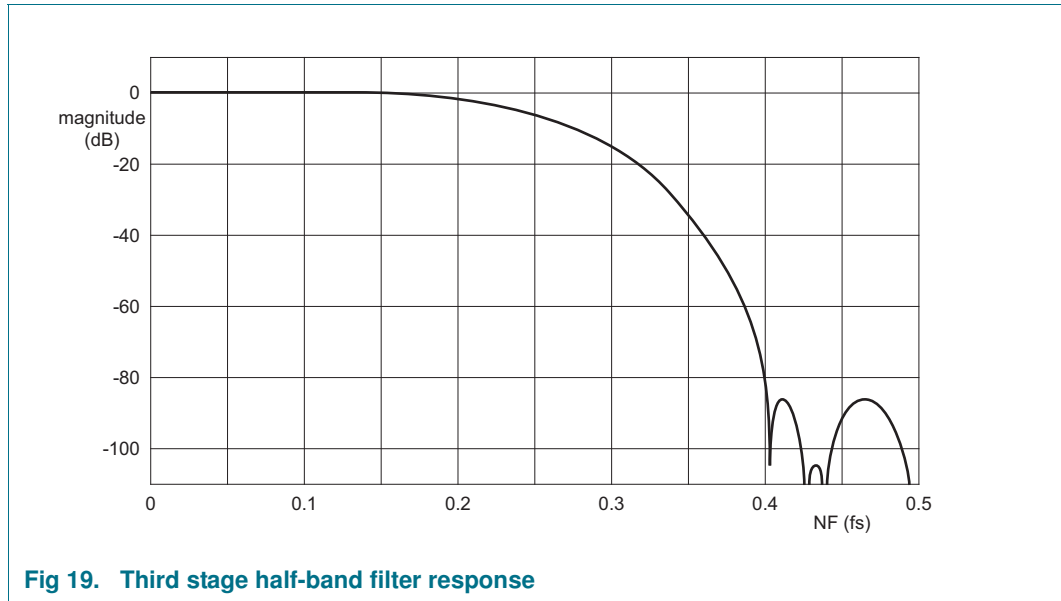

Fig 19. Third stage half-band filter response

Table 14: Interpolation filter coefficients

First interpolation filter			Second interpolation filter			Third interpolation filter		
Lower	Upper	Value	Lower	Upper	Value	Lower	Upper	Value
-	H(27)	+65536	H(11)	-	+32768	H(7)	-	+1024
H(26)	H(28)	+41501	H(10)	H(12)	+20272	H(6)	H(8)	+615
H(25)	H(29)	0	H(9)	H(13)	0	H(5)	H(9)	0
H(24)	H(30)	-13258	H(8)	H(14)	-5358	H(4)	H(10)	-127
H(23)	H(31)	0	H(7)	H(15)	0	H(3)	H(11)	0
H(22)	H(32)	+7302	H(6)	H(16)	+1986	H(2)	H(12)	+27
H(21)	H(33)	0	H(5)	H(17)	0	H(1)	H(13)	0
H(20)	H(34)	-4580	H(4)	H(18)	-654	H(0)	H(14)	-3
H(19)	H(35)	0	H(3)	H(19)	0	-	-	-
H(18)	H(36)	+2987	H(2)	H(20)	+159	-	-	-
H(17)	H(37)	0	H(1)	H(21)	0	-	-	-
H(16)	H(38)	-1951	H(0)	H(22)	-21	-	-	-
H(15)	H(39)	0	-	-	-	-	-	-
H(14)	H(40)	+1250	-	-	-	-	-	-
H(13)	H(41)	0	-	-	-	-	-	-
H(12)	H(42)	-773	-	-	-	-	-	-
H(11)	H(43)	0	-	-	-	-	-	-
H(10)	H(44)	+456	-	-	-	-	-	-
H(9)	H(45)	0	-	-	-	-	-	-
H(8)	H(46)	-252	-	-	-	-	-	-
H(7)	H(47)	0	-	-	-	-	-	-
H(6)	H(48)	+128	-	-	-	-	-	-
H(5)	H(49)	0	-	-	-	-	-	-
H(4)	H(50)	-58	-	-	-	-	-	-

Table 14: Interpolation filter coefficients ...continued

First interpolation filter			Second interpolation filter			Third interpolation filter		
Lower	Upper	Value	Lower	Upper	Value	Lower	Upper	Value
H(3)	H(51)	0	-	-	-	-	-	-
H(2)	H(52)	+22	-	-	-	-	-	-
H(1)	H(53)	0	-	-	-	-	-	-
H(0)	H(54)	-6	-	-	-	-	-	-

Equation 1 defines the dependency of the FIR1 output Y(m) on its inputs X(m):

$$Y(m) = \frac{1}{H(27)} \times \sum_{n=0}^{n=54} [H(n):X(m-n)] \tag{1}$$

Equation 2 defines the dependency of the FIR2 output Y(m) on its inputs X(m):

$$Y(m) = \frac{1}{H(11)} \times \sum_{n=0}^{n=22} [H(n):X(m-n)] \tag{2}$$

Equation 3 defines the dependency of the FIR3 output Y(m) on its inputs X(m):

$$Y(m) = \frac{1}{H(7)} \times \sum_{n=0}^{n=14} [H(n):X(m-n)] \tag{3}$$

### 10.11 Single SideBand Modulator (SSBM)

The SSBM is a quadrature modulator that enables mixing the I data and Q data with the sine and cosine signals generated by the NCO to generate path A and path B (see Figure 20).

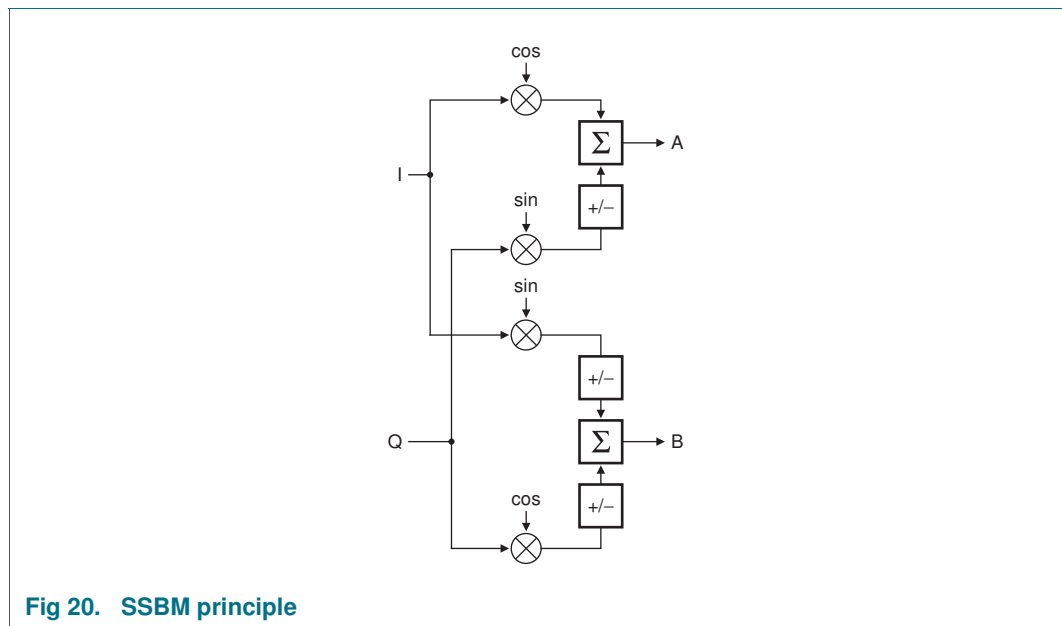

Fig 20. SSBM principle

The frequency of the NCO is programmed over 40 bits. NCO enables inverting the sine component to operate a positive or negative, lower or upper SSB upconversion (see register TXCFG in [Table 23](#)).

### 10.11.1 NCO in 40 bits

When using NCO, the frequency can be set over 40 bits by five registers, FREQNCO\_B0 to FREQNCO\_B4 (see [Table 25](#)).

The frequency is calculated with [Equation 4](#).

$$f_{NCO} = \frac{M \times f_s}{2^{40}} \quad (4)$$

Where:

- M is the two's complement coding representation of FREQ\_NCO[39:0]
- $f_s$  is the DAC clock sampling frequency

The default settings are:

- $f_{NCO} = 96$  MHz
- $f_s = 640$  Msps

Registers PHINCO\_LSB and PHINCO\_MSB over 16 bits from 0° to 360° (see [Table 31](#)) can set the phase of the NCO.

### 10.11.2 NCO low power

The five MSB-bits of register FREQNCO\_B4 (bits FREQ\_NCO[39:35]; see [Table 25](#)) can set the frequency, when using NCO low power (bit NCO\_LP\_SEL; see [Table 23](#)).

The frequency is calculated with [Equation 5](#).

$$f_{NCO} = \frac{M \times f_s}{2^5} \quad (5)$$

Where:

- M is the two's complement coding representation of FREQ\_NCO[39:35]
- $f_s$  is the DAC clock sampling frequency

The five MSB-bits of register PHINCO\_MSB (see [Table 31](#)) can set the phase of the NCO low power.

### 10.11.3 Complex modulator

The complex modulator upconverts the single side band by mixing NCO signals and I and Q input signals. [Table 15](#) shows the various possibilities set by bits MODULATION[2:0] of register TXCFG (see [Table 23](#)).

The effect of the MODULATION parameter is better viewed after mixing the A and B signal with a LO frequency through an IQ modulator:

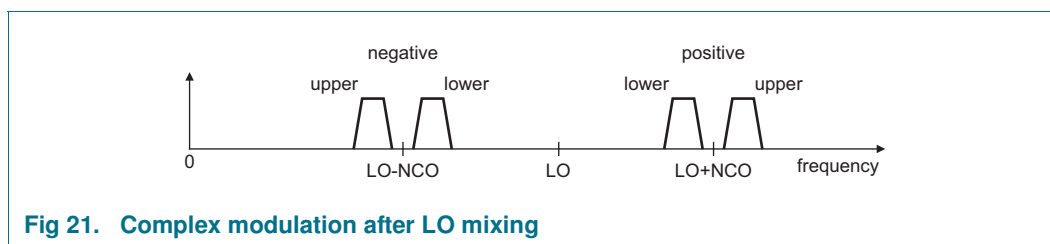

Fig 21. Complex modulation after LO mixing

Table 15. Complex modulator operation mode

MODULATION[2:0]	Mode	Path A	Path B
000	bypass	$I(t)$	$Q(t)$
001	positive upper ssb	$I(t) \times \cos(\omega_{NCO} \times t) - Q(t) \times \sin(\omega_{NCO} \times t)$	$I(t) \times \sin(\omega_{NCO} \times t) + Q(t) \times \cos(\omega_{NCO} \times t)$
010	positive lower ssb	$I(t) \times \cos(\omega_{NCO} \times t) + Q(t) \times \sin(\omega_{NCO} \times t)$	$I(t) \times \sin(\omega_{NCO} \times t) - Q(t) \times \cos(\omega_{NCO} \times t)$
011	negative upper ssb	$I(t) \times \cos(\omega_{NCO} \times t) - Q(t) \times \sin(\omega_{NCO} \times t)$	$-I(t) \times \sin(\omega_{NCO} \times t) - Q(t) \times \cos(\omega_{NCO} \times t)$
100	negative lower ssb	$I(t) \times \cos(\omega_{NCO} \times t) + Q(t) \times \sin(\omega_{NCO} \times t)$	$-I(t) \times \sin(\omega_{NCO} \times t) + Q(t) \times \cos(\omega_{NCO} \times t)$
others	not defined	-	-

### 10.11.4 Minus 3dB

In normal use, a full-scale pattern is also full-scale at the DAC output. Nevertheless, when the I data and Q data come close to full-scale simultaneously, some clipping can occur. The Minus 3dB function (bit MINUS\_3DB of register DAC\_OUT\_CTRL; see [Table 28](#)) can be used to reduce the 3 dB gain in the modulator. It retains a full-scale range at the DAC output without added interferers.

### 10.12 Inverse (sin x) / x

A selectable FIR filter is incorporated to compensate the (sin x) / x effect caused by the roll-off effect of the DAC. This filter has no effect at DC. It introduces a gain for high frequency. The coefficients are represented in [Table 16](#). The filter response is presented in [Figure 22](#).

Table 16. Inversion filter coefficients

First interpolation filter		
Lower	Upper	Value
H(1)	H(9)	+1
H(2)	H(8)	-4
H(3)	H(7)	+13
H(4)	H(6)	-51
H(5)	-	+610

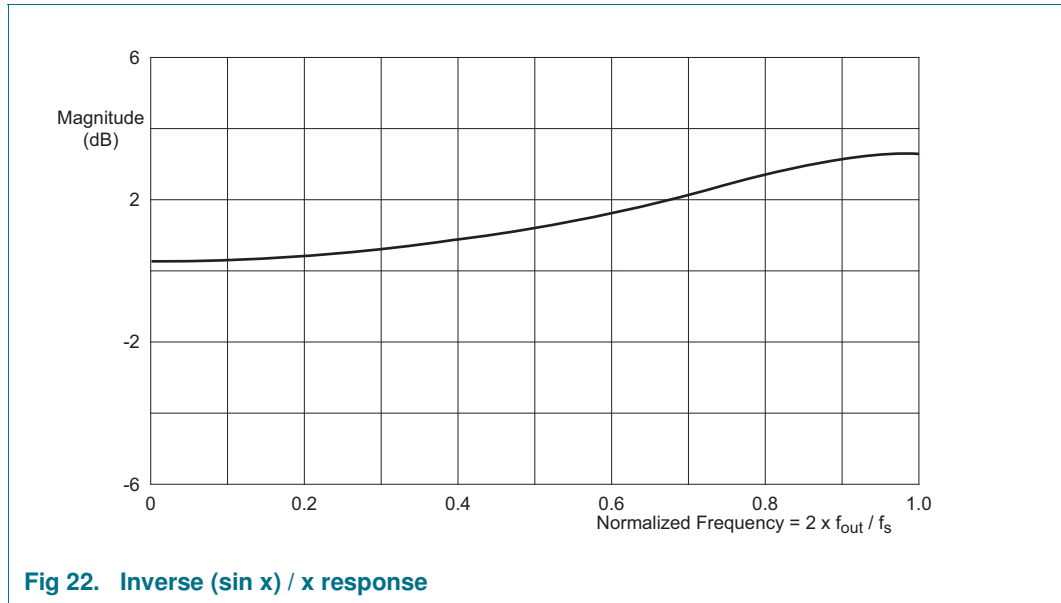

Fig 22. Inverse  $(\sin x) / x$  response

**10.13 Multiple Devices Synchronization (MDS)**

Several DAC channels can be sampled synchronously and phase coherently using the MDS feature.

When all DAC slave devices of one system receive the same MDS signal (or at least a synchronous version of this reference) all devices are time-aligned at  $\pm 1$  DAC clock accuracy at the end of the synchronization process.

**10.13.1 MDS concept**

The FPGA(s) has(have) to activate the ALIGN pins to identify the LVDS data flow start (see [Figure 23](#)).

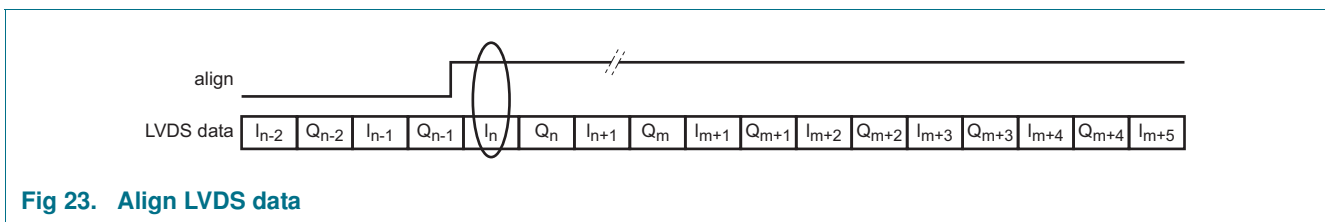

Fig 23. Align LVDS data

The ALIGN signal is used to generate a local reference inside the DAC1617D1G0 which is 'aligned' with the IQ-data.

The DAC1617D1G0 devices use the MDS signals to do the output synchronization (see [Figure 24](#)).

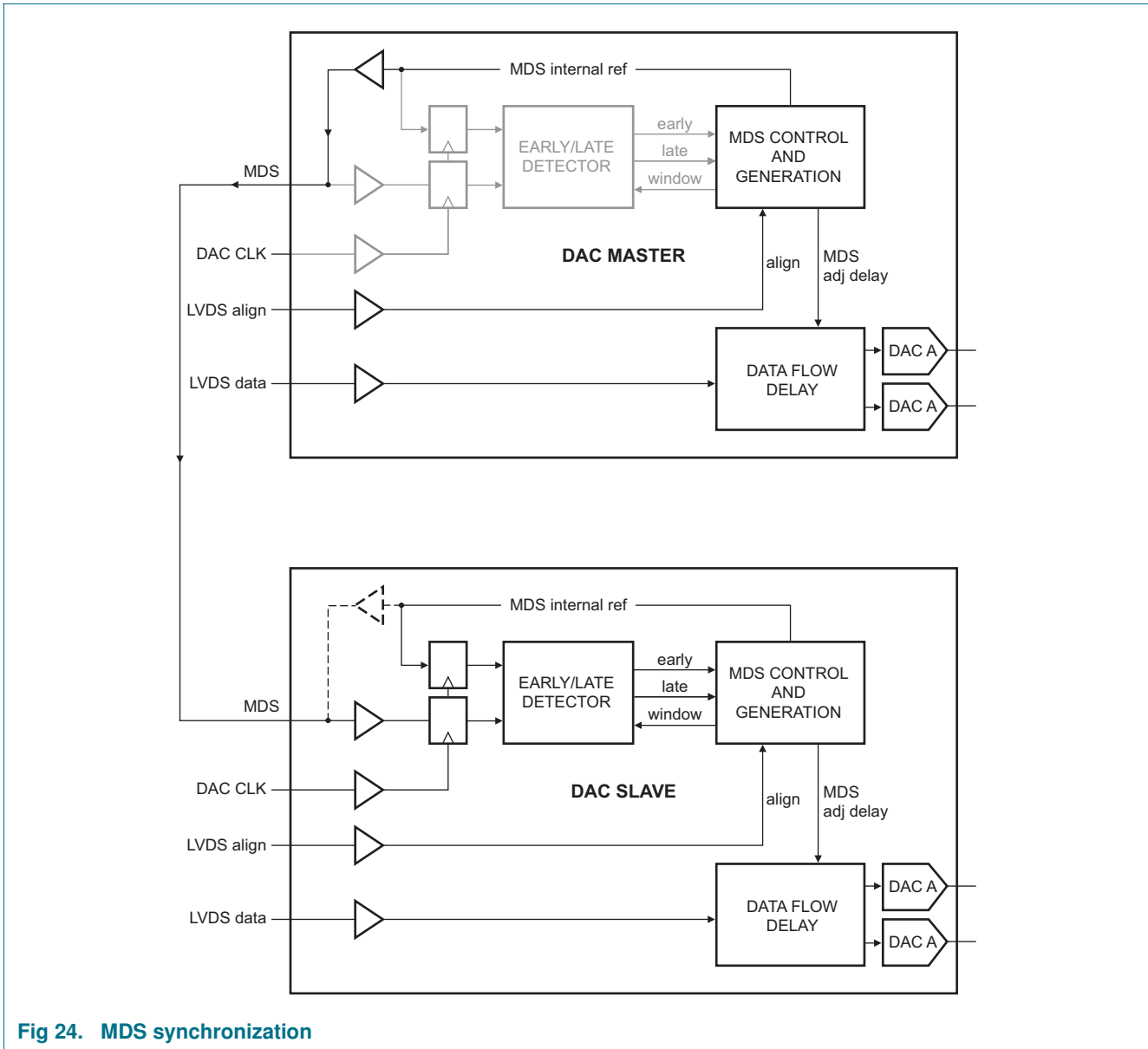

Fig 24. MDS synchronization

The signal detector of the DAC1617D1G0 detects the presence of the MDS signals. Once detected, an internal copy process of this reference starts. The MDS early/late detector block then compares the phase difference of these two signals to align the copy to its reference accurately. The alignment is done inside an "enabling window" that avoids the misinterpretation of the signal edges. This alignment process is done by moving the internal pointer of register MDS\_ADJDELAY (see [Table 43](#)) (so inserting/removing a delay in data flow). This pointer can have a preset offset. This is specified by register MDS\_OFFSET\_DLY (see [Table 42](#)). Using the MDS\_MAN and MDS\_MAN\_ADJDELAY bits in register MDS\_MAN\_ADJUSTLY register (see [Table 39](#)), the alignment can also be set manually.



During the whole alignment process, the MDS controller tries to adjust the delay to get the internal copy signal aligned to the external MDS signal. Once aligned, the MDS signal is not required anymore. it can be switched off at system level. The alignment is done just in front of the analog DACs cores ensuring the  $\pm 1$  DAC clock sample accuracy.

At the end of the MDS process, the MDS circuitry is disabled to avoid any analog disturbances.

The MDS feature can be used in two modes:

- All slaves mode
- Master/slaves mode

The mode can be set using the MD\_MASTER bit of register MDS\_MAIN (see [Table 36](#)).

**10.13.1.1 MDS in All slaves mode**

In this mode, each device uses its ALIGN pins signal to identify the LVDS data flow start (see [Figure 23](#)). The FPGA(s) has(have) to generate these ALIGN signals.

The FPGA is also used to generate the different MDS reference signals to enable the DAC1617D1G0 devices to do the synchronization of the output. Use this mode when two or more DAC1617D1G0 devices must be synchronized.

[Figure 25](#) shows the MDS All slave mode schematic.

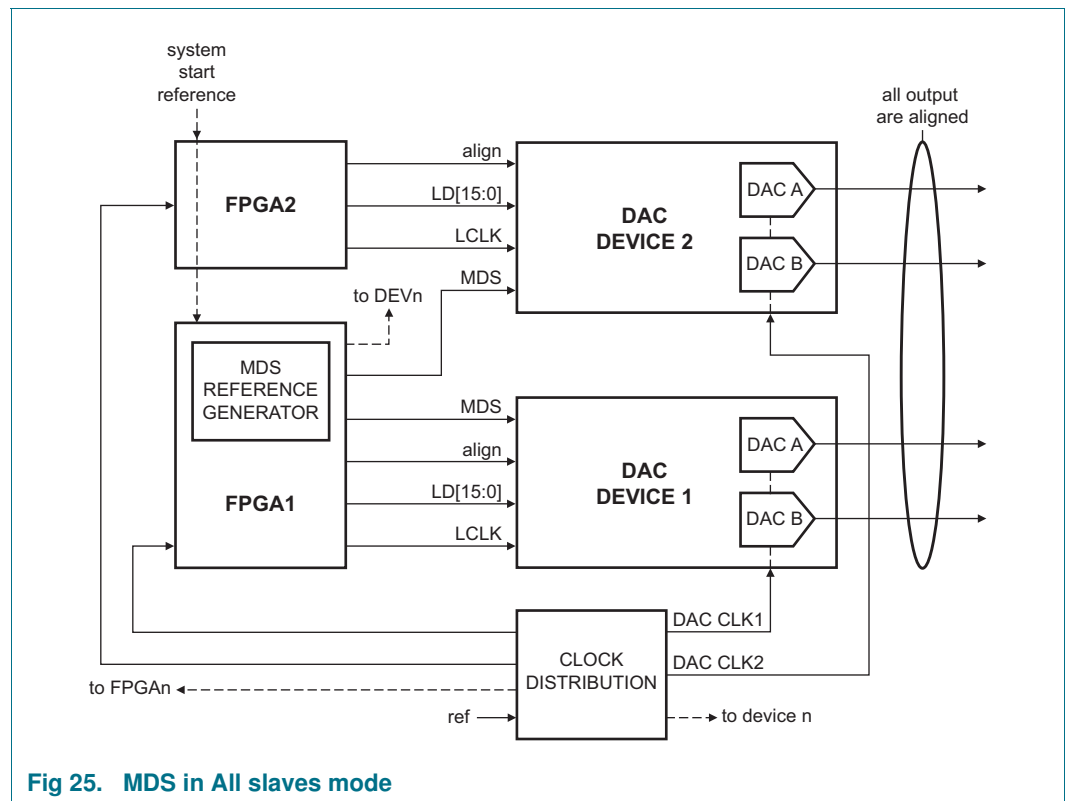

**Fig 25. MDS in All slaves mode**

10.13.1.2 MDS in Master/slaves mode

In this mode, one DAC1617D1G0 device is used as master, the other one is used as slave. The FPGA(s) still has(have) to provide the ALIGN signal to the DAC devices to identify the LVDS data flow start (see Figure 23). The master generates the reference MDS signal. The slave uses this signal to do the synchronization of the output. This mode is recommended when only two DAC1617D1G0 devices must be synchronized.

Figure 25 shows the MDS Master/slaves mode schematic.

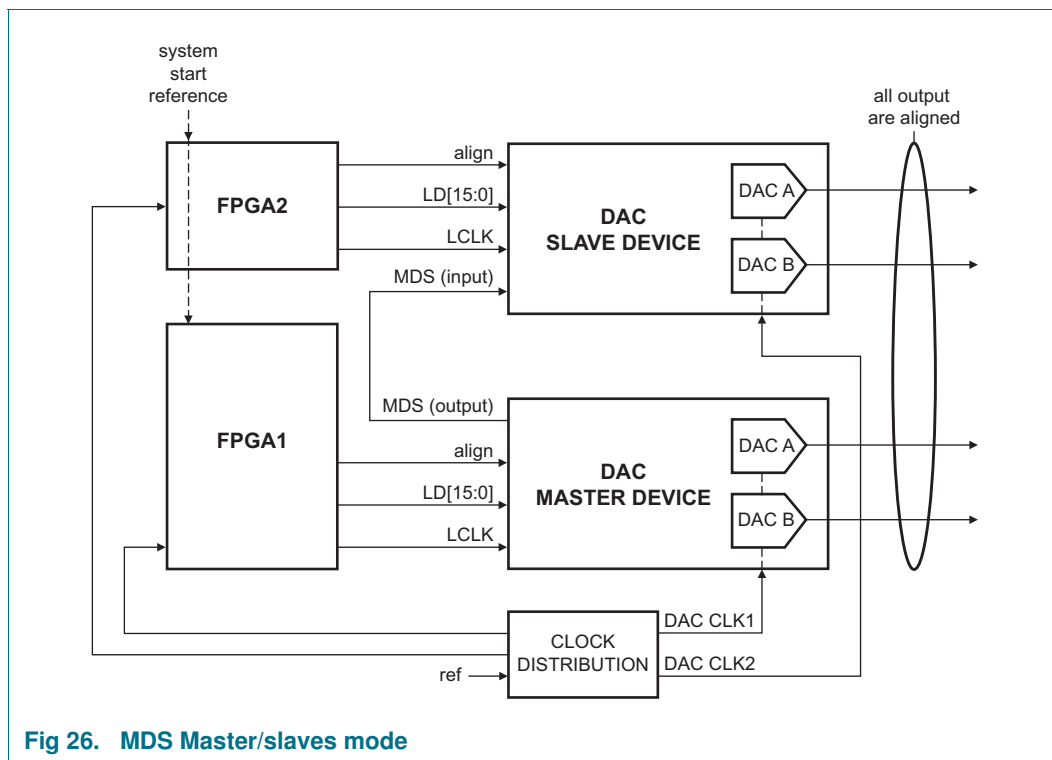

Fig 26. MDS Master/slaves mode

10.13.2 MDS flexibility and constraints

Getting a ±1 clock period alignment can become very difficult without the MDS feature. There are many sources of misalignment:

- At 1 GHz, two signals with only 15 cm PCB length difference have a 1 clock period skew. So the PCB traces off the FPGA reference clock, the LVDS data/clock, or the DAC clock introduce delay.
- The clock generation circuit can cause delay between the different clocks.
- The most important delay comes from the internal FPGA design that can cause 1 or 2 LVDS clock delays between the different LVDS data patterns.

The DAC1617D1G0 MDS feature compensates these delays when:

- The overall delay compensated by the DAC1617D1G0 remains below ±64 DAC clock.
- Each FPGA has to activate its ALIGN signal with the beginning of the LVDS data flow start (even if the different ALIGN signals are mis-aligned)

- All slave devices use the MDS signals for the fine alignment. Any misalignment between these signals causes misalignment on the output. Minimize the delay between the different MDS signals to avoid misalignments:
  - In All slave mode: Use a low skew buffer on the FPGA to generate this signal. Use the same PCB length for all MDS signal trace distributions.
  - In Master/slave mode: Minimize the MDS PCB length between the master and the slave (or compensate the introduced MDS PCB delay manually).

## 10.14 DAC transfer function

The full-scale output current for each DAC is the sum of the two complementary current outputs:

- $I_{OA(fs)} = I_{IOUTAP} + I_{IOUTAN}$
- $I_{OB(fs)} = I_{IOUTBP} + I_{IOUTBN}$

The output current of DAC A depends on the digital input data. Bits DAC\_A\_DGAIN[11:0] of register DAC\_A\_DGAIN\_LSB (see [Table 27](#)) define the gain factor.

$$I_{IOUTAP} = I_{OA(fs)} \times \frac{(DACADGAIN)}{1024} \times \left(\frac{DATA}{65535}\right) \tag{6}$$

$$I_{IOUTAN} = I_{OA(fs)} \times \left(1 - \frac{(DACADGAIN)}{1024} \times \left(\frac{DATA}{65535}\right)\right) \tag{7}$$

The output current of DAC B depends on the digital input data. Bits DAC\_B\_DGAIN[11:0] of register DAC\_B\_DGAIN\_LSB (see [Table 27](#)) define the gain factor.

$$I_{IOUTBP} = I_{OB(fs)} \times \frac{(DACBDGAIN)}{1024} \times \left(\frac{DATA}{65535}\right) \tag{8}$$

$$I_{IOUTBN} = I_{OB(fs)} \times \left(1 - \frac{(DACBDGAIN)}{1024} \times \left(\frac{DATA}{65535}\right)\right) \tag{9}$$

It is possible to define if the DAC1617D1G0 operates with a binary input or a two's complement input (bit CODING; see [Table 22](#)).

[Table 17](#) shows the output current as a function of the input data, when  $I_{OA(fs)} = I_{OB(fs)} = 20 \text{ mA}$ .

**Table 17. DAC transfer function**

Data	I15 to I0/Q15 to Q0 (binary coding)	I15 to I0/Q15 to Q0 (two's complement coding)	IOUTAP/IOUTBP	IOUTAN/IOUTBN
0	0000 0000 0000 0000	1000 0000 0000 0000	0 mA	20 mA
...	...	...	...	...
32768	1000 0000 0000 0000	0000 0000 0000 0000	10 mA	10 mA
...	...	...	...	...
65535	1111 1111 1111 1111	0111 1111 1111 1111	20 mA	0 mA

## 10.15 Full-scale current

### 10.15.1 Regulation

The DAC1617D1G0 reference circuitry integrates an internal band gap reference voltage which delivers a 1.25 V reference on the GAPOUT pin. Decouple pin GAPOUT using a 100 nF capacitor.

The reference current is generated via an external resistor of 910  $\Omega$  (1 %) connected to VIRES. A control amplifier sets the appropriate full-scale current ( $I_{O(f_s)}$  and  $I_{OB(f_s)}$ ) for both DACs (see [Figure 27](#)).

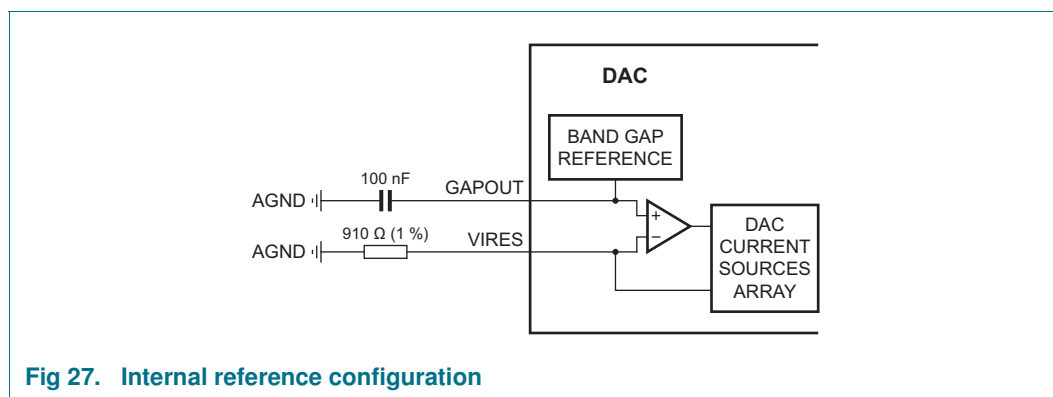

[Figure 27](#) shows the optimal configuration for temperature drift compensation because the band gap reference voltage can be matched to the voltage across the feedback resistor.

Applying an external reference voltage to the non-inverting input pin GAPOUT and disabling the internal band gap reference voltage (bit GAP\_PON of the COMMON register; see [Table 22](#)) also adjust the DAC current.

### 10.15.2 Full-scale current adjustment

The default full-scale current ( $I_{O(f_s)}$ ) is 20 mA. However, further adjustments, ranging from 8.1 mA to 34 mA, can be made to both DACs independently using the serial interface.

The settings applied to DAC\_A\_GAIN[9:0] (registers 17h and 18h; see [Table 32](#)) define the full-scale current of DAC A:

$$I_{O(f_s)} (\mu A) = 8100 + \text{DAC\_A\_GAIN}[9:0] \times 25.3 \quad (10)$$

The DAC\_B\_GAIN[9:0] (registers 19h and 1Ah; see [Table 32](#);) define the full-scale current of DAC B:

$$I_{O(f_s)} (\mu A) = 8100 + \text{DAC\_B\_GAIN}[9:0] \times 25.3 \quad (11)$$

### 10.16 Limiter/clip control

A limiter at the end of the data path saturates the output signal in case the signal does not fit the output range. This feature is activated using the CLIPPING\_ENA bit in register DAC\_OUT\_CTRL (see [Table 28](#)).

The clipping level can be programmed using the CLIPPING\_LEVEL register (see [Table 29](#)). The output range is limited (or clipped) to between  $-128 \times \text{CLIPPING\_LEVEL}$  and  $+128 \times \text{CLIPPING\_LEVEL}$ .

At the DAC analog output, the AC current range is limited to:

$$-\left(\frac{I_{O(ES)}}{2}\right) \times \left(\frac{\text{CLIPPING\_LEVEL}}{256}\right) \leq I_{IOUT} \leq +\left(\frac{I_{O(ES)}}{2}\right) \times \left(\frac{\text{CLIPPING\_LEVEL}}{256}\right) \quad (12)$$

### 10.17 Digital offset adjustment

The DAC1617D1G0 provides digital offset correction (bits DAC\_A\_OFFSET[15:0] in [Table 30](#)). This correction can be used to adjust the common-mode level at the output of each DAC. It adds an offset at the end of the digital part, just before the DACs. [Table 18](#) shows the range of variation of the digital offset.

This offset can be used to remove the LO image at the IQ modulator output.

**Table 18. Digital offset adjustment**

DAC_A_OFFSET[15:0] DAC_B_OFFSET[15:0] (two's complement)	Offset applied
1000 0000 0000 0000	-32768
1000 0000 0000 0001	-32767
...	...
1111 1111 1111 1111	-1
0000 0000 0000 0000	0
0000 0000 0000 0001	+1
...	...
0111 1111 1111 1110	+32766
0111 1111 1111 1111	+32767

### 10.18 Analog output

The device has two output channels, producing two complementary current outputs, which enable the reduction of even-order harmonics and noise. The pins are IOUTAP/IOUTAN and IOUTBP/IOUTBN. Connect these pins via a load resistor  $R_L$  to the 3.3 V analog power supply ( $V_{DDA(3V3)}$ ).

[Figure 28](#) shows the equivalent analog output circuit of one DAC. This circuit includes a parallel combination of NMOS current sources and associated switches for each segment.

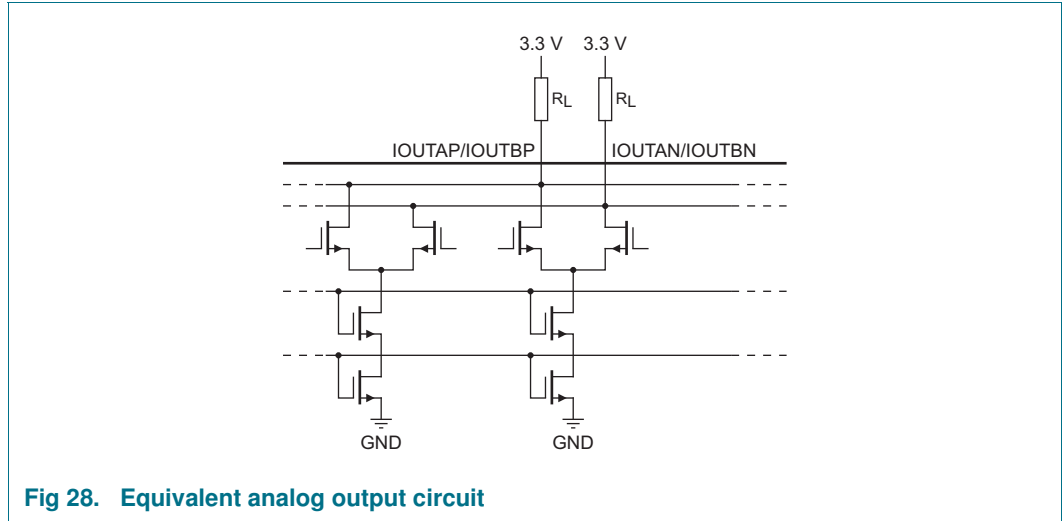

The cascode source configuration increases the output impedance of the source, which improves the dynamic performance of the DAC because there is less distortion.

Depending on the application, the various stages and the targeted performances, the device can be used for an output level of up to 2 V (p-p).

### 10.19 Auxiliary DACs

The DAC1617D1G0 integrates two auxiliary DACs, which are used to compensate any offset between the DACs and the next stage in the transmission path. Both auxiliary DACs have a 10-bit resolution and are current sources (referenced to ground).

The full-scale output current for each DAC is the sum of the two complementary current outputs:

- $I_{OAUXA(fs)} = I_{AUXAP} + I_{AUXAN}$
- $I_{OAUXB(fs)} = I_{AUXBP} + I_{AUXBN}$

The output current depends on the digital input data set by SPI registers DAC\_A\_Aux\_MSB (bits AUX\_A[9:0]) and DAC\_B\_Aux\_MSB (bits AUX\_B[9:0]); see [Table 33](#).

$$I_{AUXAP} = I_{OAUXA(fs)} \times \left( \frac{DATAA}{1023} \right) \tag{13}$$

$$I_{AUXAN} = I_{OAUXA(fs)} \times \left( \frac{1023 - DATAA}{1023} \right) \tag{14}$$

$$I_{AUXBP} = I_{OAUXB(fs)} \times \left( \frac{DATAB}{1023} \right) \tag{15}$$

$$I_{AUXBN} = I_{OAUXB(fs)} \times \left( \frac{1023 - DATAB}{1023} \right) \tag{16}$$

[Table 19](#) shows the output current as a function of the auxiliary DACs data DATAA and DATAB in [Equation 13](#) to [Equation 16](#).

**Table 19. Auxiliary DAC transfer function**

DATAA; DATAB	AUX_A[9:2]/AUX_A[1:0]; AUX_B[9:0]/AUX_B[1:0] (binary coding)	I <sub>AUXAP</sub> ; I <sub>AUXBP</sub> (mA)	I <sub>AUXAN</sub> ; I <sub>AUXBN</sub> (mA)
0	00 0000 0000	0	3.1
...	...	...	...
512	10 0000 0000	1.55	1.55
...	...	...	...
1023	11 1111 1111	3.1	0

## 10.20 Output configuration

The DAC1617D1G0 supports various output configurations.

The system application must check that for IOUTA/IOUTB output, the output compliance range ( $V_o$ ) and the common-mode output voltage ( $V_{o(cm)}$ ) specification points are respected to define other configurations.

Similarly, the system application must check that the output compliance range ( $V_o$ ) specification point is respected for AUXA/AUXB DAC (if used).

The common-mode voltage ( $V_{o(cm)}$ ) value for each IOUTA/IOUTB pin depends on the DC resistor(s) connected to these pins and the IOUT DC sink currents on these pins.

[Equation 17](#) defines the DC sink output current is:

$$I_{O(sink)}(DC) = I_{bias}(DC) + \frac{I_{O(fs)}}{2} \quad (17)$$

Where:

- $I_{O(fs)}$  = full-scale output current
- $I_{bias}(DC)$  = DC bias current

The common-mode voltage ( $V_{o(cm)}$ ) value for each AUXA/AUXB pins depend on the DC resistor(s) connected to these pins and the AUX DC source currents.

[Equation 18](#) defines these AUX DC source currents:

$$I_{O(source)}(DC) = \frac{I_{O(fs)}}{2} \quad (18)$$

Where:

- $I_{O(fs)}$  = full-scale output current

The output compliance range ( $V_o$ ) of all DAC outputs depends on the AC resistor load connected to the DAC:

$$V_{O(max)} = V_{O(cm)} + \frac{I_{O(fs)}}{2} \times R_{AC} \tag{19}$$

$$V_{O(min)} = V_{O(cm)} - \frac{I_{O(fs)}}{2} \times R_{AC} \tag{20}$$

Where:

- $V_{O(cm)}$  = common-mode output voltage
- $I_{O(fs)}$  = full-scale output current
- $R_{AC}$  = DAC outputs AC resistor load

**10.20.1 Basic output configuration**

The use of a differentially coupled transformer output (see [Figure 29](#)) provides optimum distortion performance. In addition, it helps to match the impedance and provides electrical isolation.

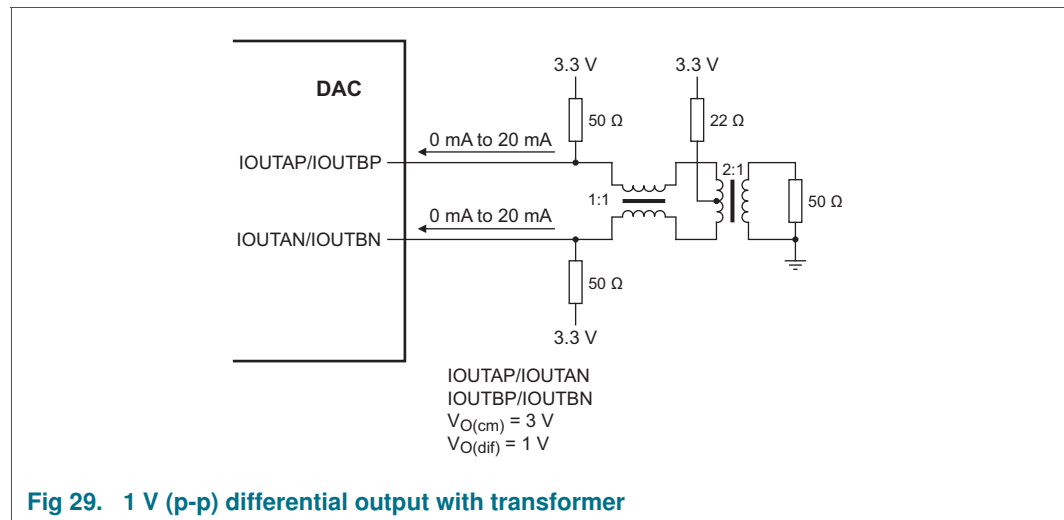

**Fig 29. 1 V (p-p) differential output with transformer**

The DAC1617D1G0 can operate a differential output of up to 2 V (p-p). In this configuration, connect the center tap of the transformer to a 33 Ω resistor, which is connected to the 3.3 V analog power supply. This adjusts the DC common-mode to around 2.8 V (see [Figure 30](#)).



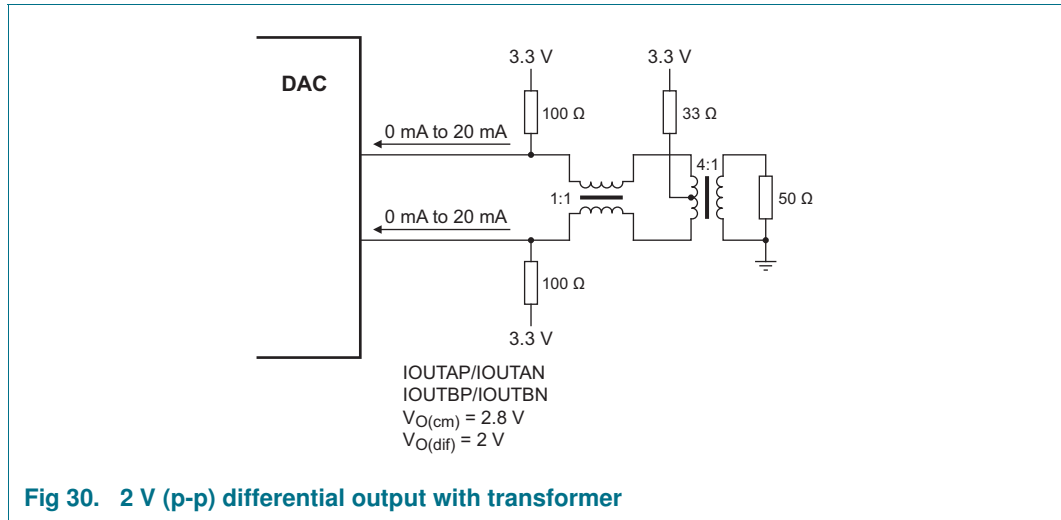

**10.20.2 Low input impedance IQ-modulator interface**

The DAC1617D1G0 can be easily connected to low input impedance IQ-modulators. The image of the local oscillator can be canceled using the digital offset control in the device.

Figure 31 shows an example of a connection between the DAC1617D1G0 and a low input impedance modulator.

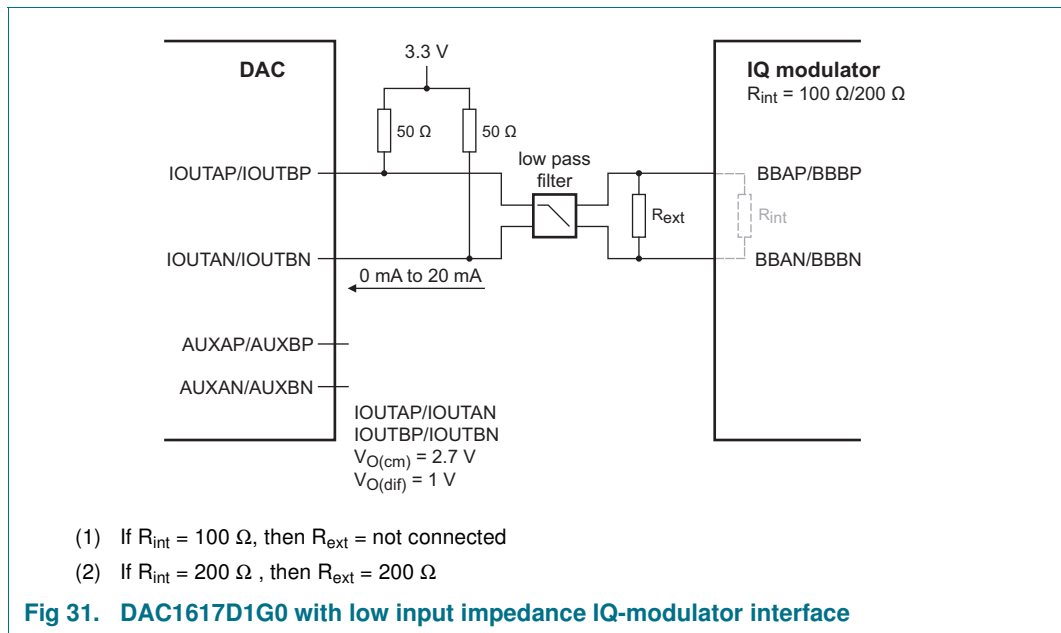

**10.20.3 IQ-modulator - DC interface**

When the system operation requires to keep the DC component of the spectrum, the DAC1617D1G0 can use a DC interface to connect an IQ-modulator. In this case, the image of the local oscillator can be canceled using the digital offset control in the device.

Figure 32 shows an example of a connection to an IQ modulator with a 1.7 V common input level.

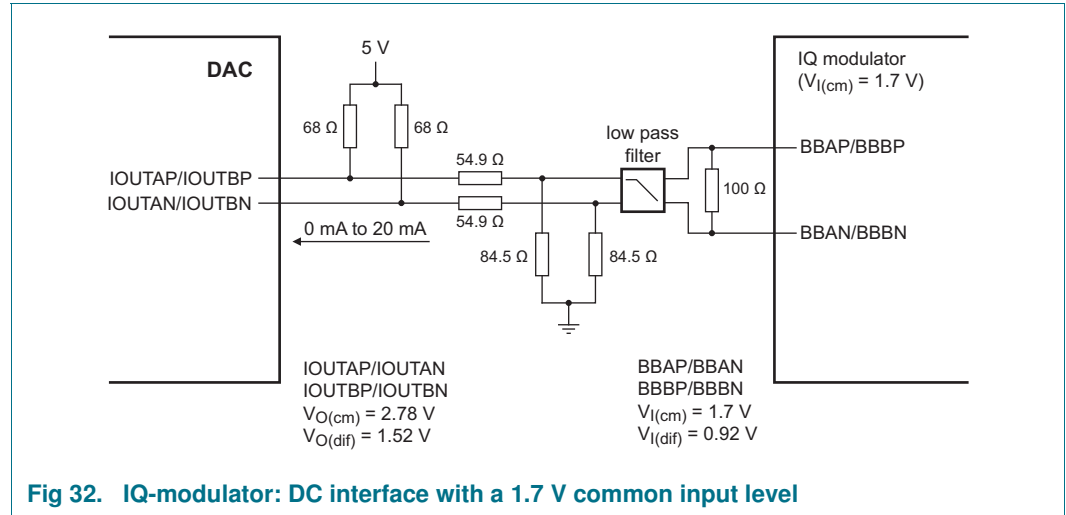
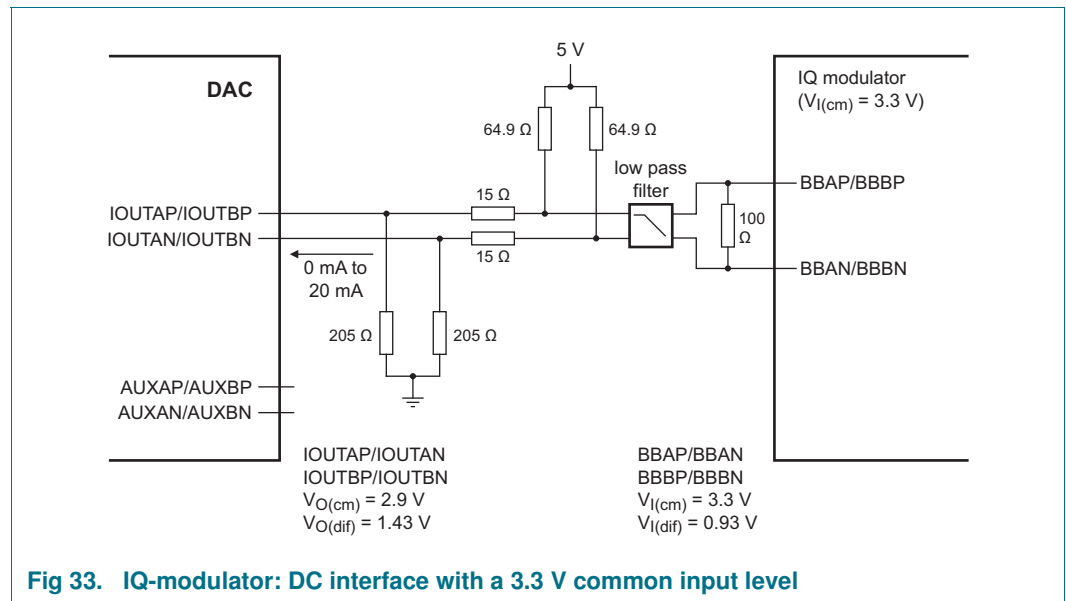
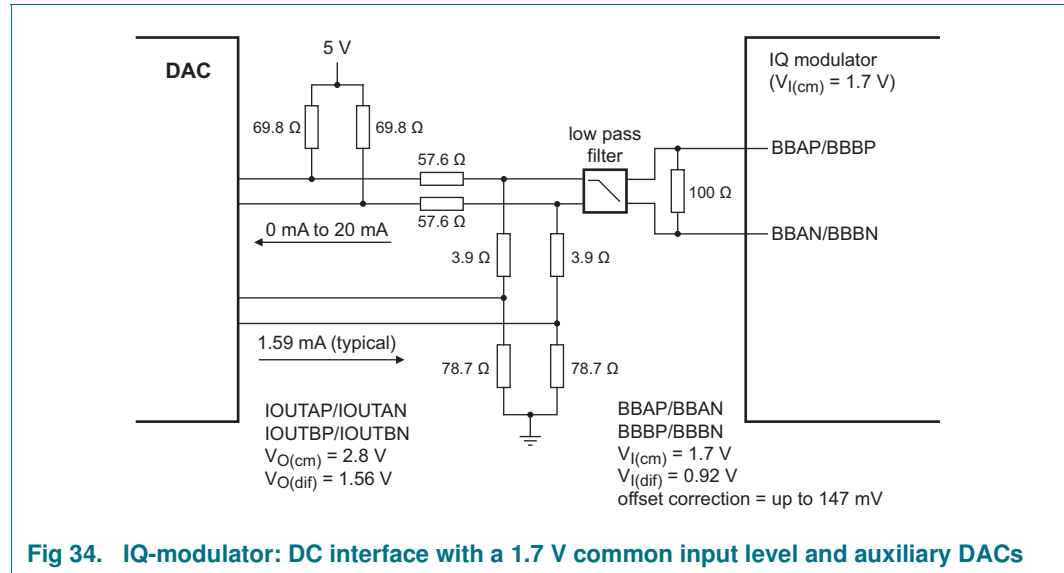

Figure 33 shows an example of a connection to an IQ-modulator with a 3.3 V common input level.



The auxiliary DACs can be used to control the offset within an accurate range or with accurate steps.

Figure 34 shows an example of a connection to an IQ-modulator with a 1.7 V common input level and auxiliary DACs.



The constraints to adjust the interface are:

- The output compliance range of the DAC
- The output compliance range of the auxiliary DACs
- The input common-mode level of the IQ-modulator
- The range of offset correction

10.20.4 IQ-modulator - AC interface

Use the DAC1617D1G0 AC-coupled when the IQ-modulator common-mode voltage is close to ground. The auxiliary DACs are required for local oscillator cancelation.

Figure 35 shows an example of a connection to an IQ-modulator with a 0.5 V common input level and auxiliary DACs.

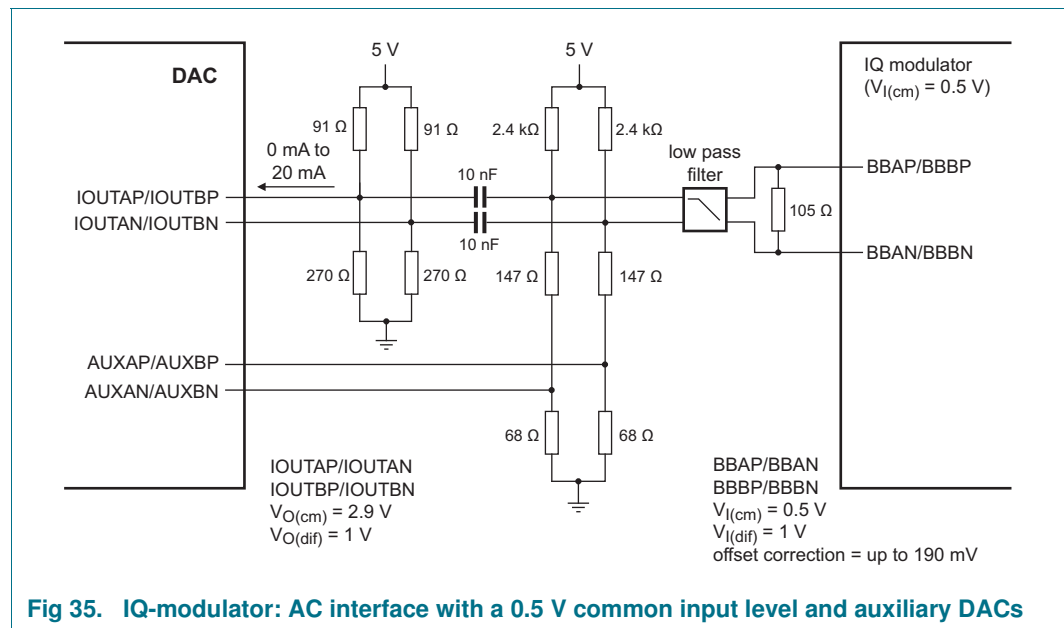

10.21 Design recommendations

10.21.1 Power and grounding

Use a separate power supply regulator for the generation of the 1.8 V analog power (pins 65, 62, 55, 69, 72 and 58) and the 1.8 V digital power (pins 12, 19, 36, 26 and 43) to ensure optimal performance.

Also, include individual LC decoupling for the following six sets of power pins:

- $V_{DDA(1V8)}_{P1}$  (pin 62)
- $V_{DDA(1V8)}_{P2}$  (pin 65)
- $V_{DDA(1V8)}$  (pins 55, 69, 72 and 58)
- $V_{DDD}$  (pins 12, 19, 26, 36, and 43)
- $V_{DDA(3V3)}$  (pins 59 and 68)

Use at least two capacitors for each power pin decoupling. Locate these capacitors as close as possible to the DAC1617D1G0 power pins.

The die pad is used for both the power dissipation and electrical grounding. Insert several vias ( $7 \times 7$  typical) to connect the internal ground plane to the top layer die area.

## 10.22 Configuration interface

### 10.22.1 Register description

The DAC1617D1G0 incorporates more than the 32 SPI registers allowed by the address value A[4:0]. It uses three SPI register pages (page\_00, page\_01, and page\_0A), each containing 32 registers. The 32nd register of each page indicates which page is currently addressed (00h, 01h or 0Ah).

Page 00h (see [Table 21](#)) is dedicated to the main control of the DAC1617D1G0:

- Mode selection
- NCO control
- Auxiliary DAC control
- Gain/phase/offset control
- Power-down control

Page 01h (see [Table 35](#)) is dedicated to:

- Multi-Device Synchronization (MDS)
- DAC analog core control (biasing current, Sleep mode)

Page 0Ah (see [Table 53](#)) is dedicated to the LVDS input interface configuration.

### 10.22.2 SPI start-up sequence

The following SPI sequence shows the list of commands to be used to start the DAC1617D1G25 in interpolation  $\times 4$  mode, with NCO frequency = 153.6 MHz ( $f_{\text{DAC}} = 983.04$  MHz), PLL bypass mode, and without inverse ( $\sin x$ ) /  $x$ . Other start-up sequences can be easily derived from this sequence:

**Table 20. SPI start-up sequence**

Step	SPI (address, data)	Comment
1	Write(0x1F, 0x00)	select SPI (page 0)
2	Write(0x00, 0x47)	reset SPI
3	Write(0x01, 0x86)	set NCO on with positive upper sideband conversion, interpolation $\times 4$ , No inverse ( $\sin x$ ) / $x$
4	Write(0x02, 0xA0)	PLL in bypass mode
5	Write(0x04, 0xFF)	select NCO frequency (FREQ_NCO[7:0])
6	Write(0x05, 0xFC)	select NCO frequency (FREQ_NCO[15:8])
7	Write(0x06, 0xFF)	select NCO frequency (FREQ_NCO[23:16])
8	Write(0x07, 0xFF)	select NCO frequency (FREQ_NCO[31:24])
9	Write(0x08, 0x27)	select NCO frequency (FREQ_NCO[39:32])
10	Write(0x1F, 0x01)	select SPI (page 1)
11	Write(0x15, 0x0A)	set DAC_current_6 to 0X0A in order to guaranty good performance over process/temperature/voltage
12	Write(0x1F, 0x0A)	select SPI (page A)

Table 20. SPI start-up sequence ...continued

Step	SPI (address, data)	Comment
13	Write(0x0A, 0x33)	specify LVDS interface setting (no DAC A/B swapping, no parity check, no data enable, ...)
14	Write(0x0B, 0x01)	set CDI block setting (interpolation x4, CDI mode)
15	Write(0x00, 0x00)	release LVDS reset (start of the DAC1617)

10.22.3 Page 0 register allocation map

Table 21 shows an overview of all registers on page 0 (00h in hexadecimal).

Table 21. Page\_00 register allocation map

Address	Register name	R/W	Bit definition									Default	
			Bit 7	Bit 6	Bit 5	Bit 4	Bit 3	Bit 2	Bit 1	Bit 0	Bin	Hex	
0 00h	COMMON	R/W	3W_SPI	SPI_RST	-	-	-	CODING	IC_PON	GAP_PON	1000 0111	87h	
1 01h	TXCFG	R/W	NCO_ON	NCO_LP_SEL	INV_SIN_SEL	MODULATION[2:0]			INTERPOLATION[1:0]		0000 0001	01h	
2 02h	PLLCFG	R/W	PLL_BP	PLL_BUF_PD	PLL_PLL_PD	PLL_DIV[1:0]		PLL_PHASE[1:0]		PLL_OSC_PD	1010 0001	A1h	
4 04h	FREQNCO_B0	R/W	FREQ_NCO[7:0]									0110 0110	66h
5 05h	FREQNCO_B1	R/W	FREQ_NCO[15:8]									0110 0110	66h
6 06h	FREQNCO_B2	R/W	FREQ_NCO[23:16]									0110 0110	66h
7 07h	FREQNCO_B3	R/W	FREQ_NCO[31:24]									0010 0110	66h
8 08h	FREQNCO_B4	R/W	FREQ_NCO[39:32]									0010 0110	26h
9 09h	PH_CORR_CTL0	R/W	PHASE_COR[7:0]									0000 0000	00h
10 0Ah	PH_CORR_CTL1	R/W	PH_COR_ENA	-	-	PHASE_COR[12:8]						0000 0000	00h
11 0Bh	DAC_A_DGAIN_LSB	R/W	DAC_A_DGAIN[7:0]									1101 0100	50h
12 0Ch	DAC_A_DGAIN_MSB	R/W	-	-	-	-	DAC_A_DGAIN[11:8]				0000 1011	0Bh	
13 0Dh	DAC_B_DGAIN_LSB	R/W	DAC_B_DGAIN[7:0]									1101 0100	50h
14 0Eh	DAC_B_DGAIN_MSB	R/W	-	-	-	-	DAC_B_DGAIN[11:8]				0000 0010	0Bh	
15 0Fh	DAC_OUT_CTRL	R/W	-	-	-	-	A_DGAIN_E	B_DGAIN_E	MINUS_3DB	CLIPPING_ENA	0000 0000	00h	

**Table 21. Page\_00 register allocation map ...continued**

Address	Register name	R/W	Bit definition								Default	
			Bit 7	Bit 6	Bit 5	Bit 4	Bit 3	Bit 2	Bit 1	Bit 0	Bin	Hex
16 10h	DAC_CLIPPING	R/W	CLIPPING_LEVEL[7:0]								1111 1111	FFh
17 11h	DAC_A_OFFSET_LSB	R/W	DAC_A_OFFSET[7:0]								0000 0000	00h
18 12h	DAC_A_OFFSET_MSB	R/W	DAC_A_OFFSET[15:8]								0000 0000	00h
19 13h	DAC_B_OFFSET_LSB	R/W	DAC_B_OFFSET[7:0]								0000 0000	00h
20 14h	DAC_B_OFFSET_MSB	R/W	DAC_B_OFFSET[15:8]								0000 0000	00h
21 15h	PHINCO_LSB	R/W	PH_NCO[7:0]								0000 0000	00h
22 16h	PHINCO_MSB	R/W	PH_NCO[15:8]								0000 0000	00h
23 17h	DAC_A_GAIN1	R/W	DAC_A_GAIN[7:0]								1101 1000	D8h
24 18h	DAC_A_GAIN2	R/W	DAC_A_GAIN[9:8]	-	-	-	-	-	-	0100 0000	40h	
25 19h	DAC_B_GAIN1	R/W	DAC_B_GAIN[7:0]								1101 1000	D8h
26 1Ah	DAC_B_GAIN2	R/W	DAC_B_GAIN[9:8]	-	-	-	-	-	-	0100 0000	40h	
27 1Bh	DAC_A_AUX_MSB	R/W	AUX_A[9:2]								1000 0000	80h
28 1Ch	DAC_A_AUX_LSB	R/W	AUX_A_PON	-	-	-	-	-	AUX_A[1:0]	1000 0000	80h	
29 1Dh	DAC_B_AUX_MSB	R/W	AUX_B[9:2]								1000 0000	80h
30 1Eh	DAC_B_AUX_LSB	R/W	AUX_B_PON	-	-	-	-	-	AUX_B[1:0]	1000 0000	80h	
31 1Fh	PAGE_ADDRESS	R/W	-	-	-	-	-	PAGE[2:0]		0000 0000	00h	



### 10.22.4 Page 0 bit definition detailed description

The tables in this section contain detailed descriptions of the page 0 registers.

**Table 22. Register COMMON (address 00h) bit description**

Default values are shown highlighted.

Bit	Symbol	Access	Value	Description
7	3W_SPI	R/W		serial interface bus type
			0	4-wire SPI
			<b>1</b>	<b>3-wire SPI</b>
6	SPI_RST	R/W		serial interface reset
			<b>0</b>	<b>no reset</b>
			1	performs a reset on all registers except address 00h
2	CODING	R/W		coding of input word
			0	two's complement coding
			<b>1</b>	<b>unsigned format</b>
1	IC_PON	R/W		IC power control
			0	all circuits (digital and analog, except SPI) are in power-down
			<b>1</b>	<b>all circuits (digital and analog, except SPI) are switched on</b>
0	GAP_PON	R/W		internal band gap power control
			0	band gap is power-down
			<b>1</b>	<b>internal band gap references are switched on</b>

**Table 23. Register TXCFG (address 01h) bit description**

Default values are shown highlighted.

Bit	Symbol	Access	Value	Description
7	NCO_ON	R/W		NCO
			<b>0</b>	<b>NCO disabled, the NCO phase is reset to 0</b>
			1	NCO enabled
6	NCO_LP_SEL	R/W		NCO low-power selection
			<b>0</b>	<b>low-power NCO disabled</b>
			1	low-power NCO enabled (frequency and phase given by the five MSB of the registers 06h and 08h, respectively)
5	INV_SIN_SEL	R/W		inverse (sin x) / x function selection
			<b>0</b>	<b>disable</b>
			1	enable
4 to 2	MODULATION[2:0]	R/W		modulation
			<b>000</b>	<b>dual DAC: no modulation</b>
			001	positive upper single sideband upconversion
			010	positive lower single sideband upconversion
			011	negative upper single sideband upconversion
			100	negative lower single sideband upconversion
			others	not defined

**Table 23. Register TXCFG (address 01h) bit description ...continued**

Default values are shown highlighted.

Bit	Symbol	Access	Value	Description
1 to 0	INTERPOLATION[1:0]	R/W		interpolation
			00	no interpolation
			<b>01</b>	<b>x2 interpolation</b>
			10	x4 interpolation
			11	x8 interpolation

**Table 24. Register PLLCFG (address 02h) bit description**

Default values are shown highlighted.

Bit	Symbol	Access	Value	Description
7	PLL_BP	R/W		PLL bypass
			0	DAC clock generated by PLL
			<b>1</b>	<b>DAC clock provided via external pins CLKN and CLKP (PLL bypass mode)</b>
6	PLL_BUF_PD	R/W		PLL test buffer control
			<b>0</b>	<b>Power-down mode</b>
			1	enabled
5	PLL_PLL_PD	R/W		PLL and CKGEN control
			0	Power-down mode
			<b>1</b>	<b>enable</b>
4 to 3	PLL_DIV[1:0]	R/W		PLL divider factor
			<b>00</b>	<b><math>f_s = 2 \times f_{data}</math></b>
			01	$f_s = 4 \times f_{data}$
			10	$f_s = 8 \times f$
			11	undefined
2 to 1	PLL_PHASE[1:0]	R/W		PLL phase shift
			<b>00</b>	<b>0 degrees phase shift of <math>f_s</math></b>
			01	120 degrees phase shift of $f_s$
			10	240 degrees phase shift of $f_s$
			11	240 degrees phase shift of $f_s$
0	PLL_OSC_PD	R/W		PLL oscillator output power-down
			0	Power-down mode
			<b>1</b>	<b>enabled</b>

**Table 25. NCO frequency registers (address 04h to 08h) bit description**

Default values are shown highlighted.

Address	Register	Bit	Symbol	Access	Value	Description
04h	FREQNCO_B0	7 to 0	FREQ_NCO[7:0]	R/W		NCO frequency (two's complement coding)
					-	least significant 8 bits for the NCO frequency setting
05h	FREQNCO_B1	7 to 0	FREQ_NCO[15:8]	R/W	-	intermediate 8 bits for the NCO frequency setting

**Table 25. NCO frequency registers (address 04h to 08h) bit description ...continued**

Default values are shown highlighted.

Address	Register	Bit	Symbol	Access	Value	Description
06h	FREQNCO_B2	7 to 0	FREQ_NCO[23:16]	R/W	-	intermediate 8 bits for the NCO frequency setting
07h	FREQNCO_B3	7 to 0	FREQ_NCO[31:24]	R/W	-	intermediate 8 bits for the NCO frequency setting
08h	FREQNCO_B4	7 to 0	FREQ_NCO[39:32]	R/W	-	most significant 8 bits for the NCO frequency setting

**Table 26. DAC output phase correction registers (address 09h to 0Ah) bit description**

Default values are shown highlighted.

Address	Register	Bit	Symbol	Access	Value	Description
09h	PH_CORR_CTL0	7 to 0	PHASE_COR[7:0]	R/W	-	DAC output phase correction factor (LSB) least significant 8 bits for the DAC output phase correction factor
0Ah	PH_CORR_CTL1	7	PH_COR_ENA	R/W	0	DAC output phase correction control <b>DAC output phase correction disabled</b>
					1	DAC output phase correction enabled
		4 to 0	PHASE_COR[12:8]	R/W	00000	DAC output phase correction factor MSB most significant 5 bits for the DAC output phase correction factor

**Table 27. Digital gain control registers (address 0Bh to 0Eh) bit description**

Default values are shown highlighted.

Address	Register	Bit	Symbol	Access	Value	Description
0Bh	DAC_A_DGAIN_LSB	7 to 0	DAC_A_DGAIN[7:0]	R/W	-	DAC A digital gain control least significant 8 bits for the DAC A digital gain
0Ch	DAC_A_DGAIN_MSB	3 to 0	DAC_A_DGAIN[11:8]		-	most significant 4 bits for the DAC A digital gain
0Dh	DAC_B_DGAIN_LSB	7 to 0	DAC_B_DGAIN[7:0]	R/W	-	DAC B digital gain control least significant 8 bits for the DAC B digital gain
0Eh	DAC_B_DGAIN_MSB	3 to 0	DAC_B_DGAIN[11:8]		-	most significant 4 bits for the DAC B digital gain

**Table 28. Register DAC\_OUT\_CTRL (address 0Fh)**

Default values are shown highlighted.

Bit	Symbol	Access	Value	Description
3	A_DGAIN_E	R/W		DAC A digital gain control
			0	<b>disable</b>
			1	enable

**Table 28. Register DAC\_OUT\_CTRL (address 0Fh) ...continued**

Default values are shown highlighted.

Bit	Symbol	Access	Value	Description
2	B_DGAIN_E	R/W		DAC B digital gain control
			0	<b>disable</b>
			1	enable
1	MINUS_3DB	R/W		DAC attenuation control
			0	<b>unity gain</b>
			1	-3 dB gain
0	CLIPPING_ENA	R/W		Digital DAC output clipping control
			0	<b>disable</b>
			1	enable

**Table 29. Register DAC\_CLIPPING (address 10h)**

Default values are shown highlighted.

Bit	Symbol	Access	Value	Description
7 to 0	CLIPPING_LEVEL[7:0]	R/W	-	Digital DAC output clipping level value

**Table 30. Digital offset value registers (address 11h to 14h) bit description**

Default values are shown highlighted.

Address	Register	Bit	Symbol	Access	Value	Description
11h	DAC_A_OFFSET_LSB	7 to 0	DAC_A_OFFSET[7:0]	R/W		DAC A digital offset value
					-	least significant 8 bits for the DAC A digital offset
12h	DAC_A_OFFSET_MSB	7 to 0	DAC_A_OFFSET[15:8]		-	most significant 8 bits for the DAC A digital offset
13h	DAC_B_OFFSET_LSB	7 to 0	DAC_B_OFFSET[7:0]	R/W		DAC B digital offset value
					-	least significant 8 bits for the DAC B digital offset
14h	DAC_B_OFFSET_MSB	7 to 0	DAC_B_OFFSET[15:8]		-	most significant 8 bits for the DAC B digital offset

**Table 31. NCO phase offset registers (address 15h to 16h) bit description**

Default values are shown highlighted.

Address	Register	Bit	Symbol	Access	Value	Description
15h	PHINCO_LSB	7 to 0	PH_NCO[7:0]	R/W		NCO phase offset LSB
					-	least significant 8 bits for the NCO phase setting
16h	PHINCO_MSB	7 to 0	PH_NCO[15:8]	R/W		NCO phase offset MSB
					-	most significant 8 bits for the NCO phase setting

**Table 32. Analog gain control registers (address 17h to 1Ah) bit description**

Default values are shown highlighted.

Address	Register	Bit	Symbol	Access	Value	Description
17h	DAC_A_GAIN1	7 to 0	DAC_A_GAIN[7:0]	R/W	-	DAC A analog gain control (LSB)
18h	DAC_A_GAIN2	7 to 6	DAC_A_GAIN[9:8]	R/W	-	DAC A analog gain control (MSB)
19h	DAC_B_GAIN1	7 to 0	DAC_B_GAIN[7:0]	R/W	-	DAC B analog gain control (LSB)
1Ah	DAC_B_GAIN2	7 to 6	DAC_B_GAIN[9:8]	R/W	-	DAC B analog gain control (MSB)

**Table 33. Auxiliary DAC registers (address 1Bh to 1Eh) bit description**

Default values are shown highlighted.

Address	Register	Bit	Symbol	Access	Value	Description
1Bh	DAC_A_AUX_MSB	7 to 0	AUX_A[9:2]	R/W	-	most significant 8 bits for auxiliary DAC A
1Ch	DAC_AUX_LSB	7	AUX_A_PON	R/W	0	off
					1	on
		1 to 0	AUX_A[1:0]	R/W	-	least significant 2 bits for auxiliary DAC A
1Dh	DAC_B_AUX_MSB	7 to 0	AUX_B[9:2]	R/W	-	most significant 8 bits for auxiliary DAC B
1Eh	DAC_B_AUX_LSB	7	AUX_B_PON	R/W	0	off
					1	on
		1 to 0	AUX_B[1:0]	R/W	-	least significant 2 bits for auxiliary DAC B

**Table 34. SPI\_PAGE register (address 1Fh) bit description**

Default values are shown highlighted.

Bit	Symbol	Access	Value	Description
2 to 0	PAGE[2:0]	R/W	-	SPI page address

10.22.5 Page 1 allocation map

Table 35 shows an overview of all registers on page 1 (01h in hexadecimal).

Table 35. Page 1 register allocation map

Address	Register name	R/W	Bit definition								Default <sup>[1]</sup>		
			Bit 7	Bit 6	Bit 5	Bit 4	Bit 3	Bit 2	Bit 1	Bit 0	Bin	Hex	
0	00h	MDS_MAIN	R/W	MDS_EQCHECK[1:0]		MDS_RUN	MDS_NCO	MDS_NCO_PULSE	MDS_SREF_DIS	MDS_MASTER	MDS_ENA	0000 0100	04h
1	01h	MDS_WIN_PERIOD_A	R/W	MDS_WIN_PERIOD_A[7:0]								1000 0000	80h
2	02h	MDS_WIN_PERIOD_B	R/W	MDS_WIN_PERIOD_B[7:0]								0100 0000	40h
3	03h	MDS_MISCCNTRL0	R/W	-	-	-	MDS_EVAL_ENA	MDS_PRERUN_E	MDS_PULSEWIDTH[2:0]			0001 0000	10h
4	04h	MDS_MAN_ADJUSTDLY	R/W	MDS_MAN	MDS_MAN_ADJUSTDLY[6:0]							0100 0000	40h
5	05h	MDS_AUTO_CYCLES	R/W	MDS_AUTO_CYCLES[7:0]								1000 0000	80h
6	06h	MDS_MISCCNTRL1	R/W	MDS_SR_CKEN	MDS_SR_LOCKOUT	MDS_SR_LOCK	MDS_RELOCK	MDS_LOCK_DELAY[3:0]			0000 1111	0Fh	
7	07h	MDS_OFFSET_DLY	RW	-	-	-	MDS_OFFSET_DLY[4:0]					0000 0000	00h
8	08h	MDS_ADJDELAY	RW	-	MDS_ADJDELAY[6:0]							0000 0000	00h
9	09h	MDS_STATUS0	R	EARLY	LATE	EQUAL	MDS_EQ	EARLY_ERROR	LATE_ERROR	EQUAL_FOUND	MDS_ACTIVE	uuuu uuuu	uuh
10	0Ah	MDS_STATUS1	R	-	-	ADD_ERR	MDS_EN_PHASE[1:0]		MDS_PRERUN	MDS_LOCKOUT	MDS_LOCK	uuuu uuuu	uuh
11	0Bh	INTR_CTRL	R/W	-	-	-	-	-	INTR_CLEAR	INTR_MON_DCLK_RANGE		0000 0100	04h
12	0Ch	INTR_EN	R/W	MAQB_EN	MAQA_EN	AUTO_DL_EN	AUTO_CAL_EN	FLAG_DL_EN	LCLKSAMP_EN	PARBER_EN	MON_DCLK_EN	0000 0000	00h
13	0Dh	INTR_FLAGS	R	MAQB_RDY	MAQA_RDY	AUTO_DL_RDY	AUTO_CAL_RDY	FLAG_DL_ERR	LCLKSAMP_ERR	PARBER_ERR	MON_DCLK_ERR	uuuu uuuu	uuh

Table 35. Page 1 register allocation map ...continued

Address	Register name	R/W	Bit definition									Default <sup>[1]</sup>		
			Bit 7	Bit 6	Bit 5	Bit 4	Bit 3	Bit 2	Bit 1	Bit 0	Bin	Hex		
14	0Eh	DAC_CURRENT_AUX	R/W	-	-	-	-				DAC_AUX_BIAS[3:0]		0000 0111	07h
15	0Fh	DAC_CURRENT_0	R/W	-	-	-	-				DAC_DIG_BIAS[3:0]		0000 0111	07h
16	10h	DAC_CURRENT_1	R/W	-	-	-	-				DAC_MST_BIAS[3:0]		0000 0111	07h
17	11h	DAC_CURRENT_2	R/W	-	-	-	-				DAC_DRV_BIAS[3:0]		0000 0111	07h
18	12h	DAC_CURRENT_3	R/W	-	-	-	-				DAC_SLV_BIAS[3:0]		0000 0111	07h
19	13h	DAC_CURRENT_4	R/W	-	-	-	-				DAC_CK_BIAS[3:0]		0000 0111	07h
20	14h	DAC_CURRENT_5	R/W	-	-	-	-				DAC_CAS_BIAS[3:0]		0000 0111	07h
21	15h	DAC_CURRENT_6	R/W	-	-	-	-				DAC_COM_BIAS[3:0]		0000 0111	07h
22	16h	DAC_PON_SLEEP	R/W	DAC_B_PON	DAC_B_SLEEP	DAC_B_COM_PD	DAC_B_BLEED_PD	DAC_A_PD	DAC_A_SLEEP	DAC_A_COM_PD	DAC_A_BLEED_PD	10111 011	BBh	
23	17h	DAC_CLKDIG_DELAY	R/W	-	-	-	-	-			PLL_DIG_DELAY[2:0]		0000 0010	02h
31	1Fh	PAGE_ADDRESS	R/W	-	-	-	-	-			PAGE[2:0]		0000 0000	00h

[1] u = undefined at power-up or after reset.

### 10.22.6 Page 1 bit definition detailed description

The tables in this section contain detailed descriptions of the page 1 registers.

**Table 36. MDS\_MAIN register (address 00h) bit description**

Default values are shown highlighted.

Bit	Symbol	Access	Value	Description
7 to 6	MDS_EQCHECK[1:0]	R/W		lock mode
			<b>00</b>	<b>lock when (early = 1 and late = 1)</b>
			01	lock when (early = 1, late = 1 and equal = 1)
			10	lock when equal = 1
			11	force lock (equal-check = 1)
5	MDS_RUN	R/W		evaluation process restart control
			<b>0</b>	<b>no action</b>
4	MDS_NCO	R/W	1	(0 ≥ 1) transition restarts evaluation_counter
			<b>0</b>	<b>no action</b>
3	MDS_NCO_PULSE	R/W		NCO synchronization
			<b>0</b>	<b>no action</b>
1	MDS_SREF_DIS	R/W	1	enable
			<b>0</b>	<b>no action</b>
2	MDS_SREF_DIS	R/W	1	manual control NCO tuning
			<b>0</b>	<b>no action</b>
1	MDS_MASTER	R/W		internal pulse generation
			<b>0</b>	<b>disable</b>
0	MDS_ENA	R/W	1	normal mode
			<b>0</b>	<b>disable</b>
0	MDS_ENA	R/W	1	enable
			<b>0</b>	<b>disable</b>
0	MDS_ENA	R/W	1	MDS function control
			<b>0</b>	<b>disable</b>
0	MDS_ENA	R/W	1	enable
			<b>0</b>	<b>disable</b>

**Table 37. MDS window time registers (address 01h to 02h) bit description**

Legend: \* reset value; <= mandatory value

Address	Register	Bit	Symbol	Access	Value	Description
01h	MDS_WIN_PERIOD_A	7 to 0	MDS_WIN_PERIOD_A[7:0]	R/W	-	determines MDS window LOW time
02h	MDS_WIN_PERIOD_B	7 to 0	MDS_WIN_PERIOD_B[7:0]	R/W	-	determines MDS window HIGH time

**Table 38. MDS\_MISCCNTRL0 register (address 03h) bit description**

Default values are shown highlighted.

Bit	Symbol	Access	Value	Description
4	MDS_EVAL_ENA	R/W		MDS evaluation
			0	disable
			<b>1</b>	<b>enable</b>



**Table 38. MDS\_MISCCNTRL0 register (address 03h) bit description ...continued**

Default values are shown highlighted.

Bit	Symbol	Access	Value	Description
3	MDS_PRERUN_ENA	R/W		automatic MDS start-up
			0	<b>no mds_win/mds_ref generation in advance</b>
			1	mds_win/mds_ref run-in before mds_evaluation
2 to 0	MDS_PULSEWIDTH[2:0]	R/W		width of MDS (in output clock -periods)
			000	<b>1 DAC clock period</b>
			001	2 DAC clock periods
			010 to 111	$(\text{mds\_pulsewidth} - 1) \times 4$ DAC clock periods

**Table 39. MDS\_MAN\_ADJUSTDLY register (address 04h) bit description**

Default values are shown highlighted.

Bit	Symbol	Access	Value	Description
7	MDS_MAN	R/W		adjustment delays mode
			0	<b>auto-control adjustment delays</b>
			1	manual control adjustment delays
6 to 0	MDS_MAN_ADJUSTDLY[6:0]	R/W		adjustment delay value
			-	if MDS_MAN = 0 then initial value adjustment delay
			-	if MDS_MAN = 1 then controls adjustment delay

**Table 40. MDS\_AUTO\_CYCLES register (address 05h) bit description**

Default values are shown highlighted.

Bit	Symbol	Access	Value	Description
7 to 0	MDS_AUTO_CYCLES[7:0]	R/W	-	number of evaluation cycles applied for MDS. If set to 255, the IC continuously generates/monitors the MDS pulse

**Table 41. MDS\_MISCCNTRL1 register (address 06h) bit description**

Default values are shown highlighted.

Bit	Symbol	Access	Value	Description
7	MDS_SR_CKEN	R/W	-	lock mode
			0	<b>free-running MDS_SR_CKEN</b>
			1	MDS_SR_CKEN forced low
6	MDS_SR_LOCKOUT	R/W		lockout detector soft reset
			0	<b>MDS_SR_LOCKOUT in use</b>
			1	MDS_SR_LOCKOUT forced low
5	MDS_SR_LOCK	R/W		lock detector soft reset
			0	<b>MDS_SR_LOCK in use</b>
			1	MDS_SR_LOCK forced low
4	MDS_RELOCK	R/W		relock mode
			0	<b>no action</b>
			1	relock when lockout occurs
3 to 0	MDS_LOCK_DELAY[3:0]	R/W	-	number of succeeding 'equal' detections until lock

**Table 42. MDS\_OFFSET\_DLY register (address 07h) bit description**

Default values are shown highlighted.

Bit	Symbol	Access	Value	Description
4 to 0	MDS_OFFSET_DLY[6:0]	R/W	-	delay offset for dataflow (two's complement [-16 to 15])

**Table 43. MDS\_ADJDELAY register (address 08h) bit description**

Default values are shown highlighted.

Bit	Symbol	Access	Value	Description
6 to 0	MDS_ADJDELAY[6:0]	R	-	actual value adjustment delay

**Table 44. MDS status registers (address 09h to 0Ah) bit description**

Default values are shown highlighted.

Address	Register	Bit	Symbol	Access	Value	Description
09h	MDS_STATUS0	7	EARLY	R		early signal (sampled) from early-to-late detector
					0	false
			1	true		
		6	LATE	R		late signal (sampled) from early-to-late detector
					0	false
			1	true		
		5	EQUAL	R		equal signal (sampled) from early-to-late detector
					0	false
			1	true		
		4	MDS_LOCK	R		result equal-check
					0	false
			1	true		
		3	EARLY_ERROR	R		adjustment delay maximum value stops the search
					0	false
	1	true				
2	LATE_ERROR	R		adjustment delay minimum value stops the search		
			0	false		
	1	true				
1	EQUAL_FOUND	R		evaluation logic has detected equal condition		
			0	false		
	1	true				
0	MDS_ACTIVE	R		evaluation logic active		
			0	false		
	1	true				

**Table 44. MDS status registers (address 09h to 0Ah) bit description ...continued**

Default values are shown highlighted.

Address	Register	Bit	Symbol	Access	Value	Description	
0Ah	MDS_STATUS1	5	ADD_ERR	R		adjustment delay error detection	
					0	OK	
			1	delay offset cannot be applied in available range			
		4 to 3	MDS_EN_PHASE[1:0]	R			MDS enable phase
						00	enable phase = 0
						01	enable phase = 1 (only for x2)
						10	enable phase = 2 (only for x2 and x4)
						11	enable phase = 3 (only for x2)
		2	MDS_PRERUN	R			MDS-PRERUN phase active flag
						0	false
			1	true			
		1	MDS_LOCKOUT	R			MDS_LOCKOUT detected flag
0	false						
	1	true					
0	MDS_LOCK	R			MDS_LOCK flag		
				0	false		
	1	true					

**Table 45. Interrupt control register (address 0Bh) bit description**

Default values are shown highlighted.

Bit	Symbol	Access	Value	Description
3	INTR_CTRL	R/W		internal interrupt and flags clearance
			0	disabled
			1	<b>enabled</b>
2 to 0	INTR_MON_DCLK_RANGE	R/W		Interrupt condition as related to the DCLK monitoring
			00	<b>mon_dclk_flag when mon_dclk drifts to (1 or 5) (detect small drift)</b>
			01	mon_dclk_flag when mon_dclk drifts to (2 or 4) (detect large drift)
			10	mon_dclk_flag when mon_dclk drifts to (3) (detect maximum drift)
			11	mon_dclk_flag disabled

**Table 46. Interrupt enable register (address 0Ch) bit description***Default values are shown highlighted.*

Bit	Symbol	Access	Value	Description
7	MAQB_EN	R/W		acquisition module B interrupt
			0	<b>disabled</b>
			1	enabled
			6	MAQA_EN
0	<b>disabled</b>			
			1	enabled
			5	AUTO_DL_EN
0	<b>disabled</b>			
			1	enabled
			4	AUTO_CAL_EN
0	<b>disabled</b>			
			1	enabled
			3	FLAG_DL_EN
0	<b>disabled</b>			
			1	enabled
			2	LCLKSAMP_EN
0	<b>disabled</b>			
			1	enabled
			1	PARBER_EN
0	<b>disabled</b>			
			1	enabled
			0	MON_DCLK_EN
0	<b>disabled</b>			
			1	enabled

**Table 47. INTR\_FLAGS register (address 0Dh) bit description***Default values are shown highlighted.*

Bit	Symbol	Access	Value	Description
7	MAQB_RDY	R		acquisition module B status
			0	not ready
			1	ready
			6	MAQA_RDY
0	not ready			
			1	ready
			5	AUTO_DL_RDY
0	not ready			
			1	ready
			4	AUTO_CAL_RDY
0	not ready			
			1	ready

**Table 47. INTR\_FLAGS register (address 0Dh) bit description ...continued**

Default values are shown highlighted.

Bit	Symbol	Access	Value	Description
3	FLAG_DL_ERR	R		error during MTP download
			0	no error
			1	error detected
			2	LCLKSAMP_ERR
0	no error			
			1	error detected
			1	PARBER_ERR
0	no error			
			1	error detected
			0	MON_DCLK_ERR
0	no error			
			1	error detected

**Table 48. Bias current control registers (address 0Eh to 15h) bit description**

Default values are shown highlighted.

Address	Register	Bit	Symbol	Access	Value	Description
0Eh	DAC_CURRENT_AUX	3 to 0	DAC_AUX_BIAS[3:0]	R/W	-	bias current control (see <a href="#">Table 49</a> )
0Fh	DAC_CURRENT_0	3 to 0	DAC_DIG_BIAS[3:0]	R/W	-	
10h	DAC_CURRENT_1	3 to 0	DAC_MST_BIAS[3:0]	R/W	-	
11h	DAC_CURRENT_2	3 to 0	DAC_DRV_BIAS[3:0]	R/W	-	
12h	DAC_CURRENT_3	3 to 0	DAC_SLV_BIAS[3:0]	R/W	-	
13h	DAC_CURRENT_4	3 to 0	DAC_CK_BIAS[3:0]	R/W	-	
14h	DAC_CURRENT_5	3 to 0	DAC_CAS_BIAS[3:0]	R/W	-	
15h	DAC_CURRENT_6	3 to 0	DAC_COM_BIAS[3:0]	R/W	-	

[1] All default values (except for register DAC\_current\_6) are OK for good performance over Process Voltage and Temperature.

[2] The register DAC\_current\_6 (address 0X15) must be set to 0X0A.

**Table 49. Bias current control table**

BIAS[3:0]	Deviation from nominal current
0 0 0 0	-35 %
0 0 0 1	-30 %
0 0 1 0	-25 %
0 0 1 1	-20 %
0 1 0 0	-15 %
0 1 0 1	-10 %
0 1 1 0	-5 %
0 1 1 1	+0 % (default)
1 0 0 0	+5 %
1 0 0 1	+10 %
1 0 1 0	+15 %

Table 49. Bias current control table ...continued

BIAS[3:0]	Deviation from nominal current
1 0 1 1	+20 %
1 1 0 0	+25 %
1 1 0 1	+30 %
1 1 1 0	+35 %
1 1 1 1	+40 %

Table 50. DAC\_PON\_SLEEP register (address 16h) bit description

Default values are shown highlighted.

Bit	Symbol	Access	Value	Description
7	DAC_B_PON	R/W	-	DAC B power control
			0	power-down
			1	<b>power on</b>
6	DAC_B_SLEEP	R		DAC B mode selection
			0	<b>normal operation</b>
			1	Sleep mode
5	DAC_B_COM_PD	R		commutator B control
			0	disable (power-down)
			1	<b>enable</b>
4	DAC_B_BLEED_PD	R		DAC B bleed current control
			0	disable (power-down)
			1	<b>enable</b>
3	DAC_A_PON	R		DAC A power control
			0	power-down
			1	<b>power on</b>
2	DAC_A_SLEEP	R		DAC B mode selection
			0	<b>normal operation</b>
			1	Sleep mode
1	DAC_A_COM_PD	R		commutator A control
			0	disable (power-down)
			1	<b>enable</b>
0	DAC_A_BLEED_PD	R		DAC A bleed current control
			0	disable (power-down)
			1	<b>enable</b>

Table 51. DAC\_TEST\_8 register (address 17h) bit description

Default values are shown highlighted.

Bit	Symbol	Access	Value	Description
2 to 0	PLL_DIG_DELAY[2:0]	R/W	-	digital clock delay offset of PLL/CKGEN_DIV8

**Table 52. SPI\_PAGE register (address 1Fh) bit description***Default values are shown highlighted.*

Bit	Symbol	Access	Value	Description
2 to 0	PAGE[2:0]	R/W	-	SPI page address

10.22.7 Page A register allocation map

Table 53 shows an overview of all registers on page A (0Ah in hexadecimal).

Table 53. Page\_0A register allocation map

Address	Register name	R/W	Bit definition									Default		
			Bit 7	Bit 6	Bit 5	Bit 4	Bit 3	Bit 2	Bit 1	Bit 0	Bin	Hex		
0	00h	MAIN_CNTRL	R/W	-	-	-	LD_PD	PD_CNTRL	CAL_CNTRL	RST_DCKL	RST_LCKL	0000 0011	03h	
1	01h	MAN_LDCLKDEL	R/W	-	-	-	-	LDCLK_DEL[3:0]			0000 0000	00h		
2	02h	DBG_LVDS	R/W	-	-	-	-	SBER	RESERVED			0000 0000	00h	
4	04h	RST_EXT_LDCLK	R/W	RST_EXT_LCLK_TIME[7:0]									0011 1111	3Fh
5	05h	RST_EXT_DCLK	R/W	RST_EXT_DCLK_TIME[7:0]									0010 0000	20h
6	06h	DCMSU_PREDIV	R/W	DCMSU_PREDIVIDER[7:0]									0001 1101	1Dh
8	08h	LD_POL_LSB	R/W	LD_POL[7:0]									0000 0000	00h
9	09h	LD_POL_MSB	R/W	LD_POL[15:8]									0000 0000	00h
10	0Ah	LD_CNTRL	R/W	PARITYC	DESCRAMBLE	SEL_EN[1:0]	WORD_SWAP	LDAB_SWAP	IQ_FORMAT	EDGE_LDCLK	0000 0011	03h		
11	0Bh	MISC_CNTRL	R/W	SR_CDI	RESERVED	I_LEV_CNTRL[1:0]	Q_LEV_CNTRL[1:0]	CDI_MODE[1:0]			0000 0000	00h		
12	0Ch	I_DC_LVL_LSB	R/W	I_DC_LEVEL[7:0]									0000 0000	00h
13	0Dh	I_DC_LVL_MSB	R/W	I_DC_LEVEL[15:8]									1000 0000	80h
14	0Eh	Q_DC_LVL_LSB	R/W	Q_DC_LEVEL[7:0]									0000 0000	00h
15	0Fh	Q_DC_LVL_MSB	R/W	Q_DC_LEVEL[15:8]									1000 0000	80h
16	10h	IO_MUX0	R/W	IO_SELECT0[7:0]									1111 1111	FFh



Table 53. Page\_0A register allocation map ...continued

Address	Register name	R/W	Bit definition								Default	
			Bit 7	Bit 6	Bit 5	Bit 4	Bit 3	Bit 2	Bit 1	Bit 0	Bin	Hex
17 11h	IO_MUX1	R/W	IO_SELECT1[7:0]								1111 1111	FFh
18 12h	IO_MUX2	R/W	IO_SELECT1[9:8]		-	IO_SELECT0[9:8]		-			1111 1111	FFh
27 1Bh	TYPE_ID	R	DAC	FRONTEND[1:0]		DUAL	DSP[1:0]		BIT_RES[1:0]		0011 1010	3Ch
28 1Ch	DAC_VERSION	R	DAC_VERSION_ID[7:0]								0010 1001	29h
29 1Dh	DIG_VERSION	R	DIG_VERSION_ID[7:0]								0000 0100	04h
30 1Eh	LD_VERSION	R	LVDS_VERSION_ID[7:0]								0000 1001	09h
31 1Fh	PAGE_ADDRESS	R/W	-	-	-	-	-	PAGE[2:0]		0000 0000	00h	

### 10.22.8 Page A bit definition detailed description

The tables in this section contain detailed descriptions of the page A registers.

**Table 54. Register MAIN\_CNTRL (address 00h)**

Default values are shown highlighted.

Bit	Symbol	Access	Value	Description
4	LD_PD	R/W		LVDS interface power-down (control possible only when PD_CNTRL = 1)
			<b>0</b>	<b>switched on</b>
			1	switched off
3	PD_CNTRL	R/W		power-down modes controlled by
			<b>0</b>	<b>DCMSU block</b>
			1	SPI registers
2	CAL_CNTRL	R/W		compensation delay controlled by
			<b>0</b>	<b>DCMSU block (automatic calibration)</b>
			1	SPI registers (manual control)
1	RST_DCLK	R/W		reset DCLK
			0	disable
			<b>1</b>	<b>enable</b>
0	RST_LCLK	R/W		reset LVDS clock
			0	disable
			<b>1</b>	<b>enable</b>

**Table 55. Register MAN\_LDCLKDEL (address 01h)**

Default values are shown highlighted.

Bit	Symbol	Access	Value	Description
3 to 0	LDCLK_DEL[3:0]	R/W		LVDS clock compensation delay (control only if CAL_CNTRL = 1)
			-	4-bit compensation delay for LVDS clock

**Table 56. Register DBG\_LVDS (address 02h)**

Default values are shown highlighted.

Bit	Symbol	Access	Value	Description
3	SBER	R/W		simple BER control
			<b>0</b>	<b>no action</b>
			1	simple BER active
2 to 0	RESERVED	R/W	<b>000</b>	<b>reserved</b>

**Table 57. Extension time reset registers (address 04h to 05h) bit description**

Default values are shown highlighted.

Address	Register	Bit	Symbol	Access	Value	Description
04h	RST_EXT_LCLK	7 to 0	RST_EXT_LCLK_TIME[7:0]	R/W	-	specifies extension time reset, expressed in LVDS clock periods 8 bits for the extension time reset
05h	RST_EXT_DCLK	7 to 0	RST_EXT_DCLK_TIME[7:0]	R/W	-	specify extension time reset, expressed in DCLK periods 8 bits for the extension time reset

**Table 58. Register DCMSU\_PREDIV (address 06h)**

Default values are shown highlighted.

Bit	Symbol	Access	Value	Description
7 to 0	DCMSU_PREDIVIDER[7:0]	R/W	-	predivider value for the DCMSU, expressed in LVDS clock period 8 bits for the predivider value

**Table 59. LSB/MSB of polarity registers (address 08h to 09h) bit description**

Default values are shown highlighted.

Address	Register	Bit	Symbol	Access	Value	Description
08h	LD_POL_LSB	7 to 0	LD_POL[7:0]	R/W	-	toggles polarity of corresponding bit pair within LD[7:0] most significant 6 bits for the polarity toggle
09h	LD_POL_MSB	7 to 0	LD_POL[15:8]	-	-	most significant 6 bits for the polarity toggle

**Table 60. Register LD\_CNTRL (address 0Ah)**

Default values are shown highlighted.

Bit	Symbol	Access	Value	Description
7	PARITYC	R/W	-	parity check
			0	disable
			1	enable
6	DESCRAMBLE	R/W	-	Descramble control
			0	<b>disable descrambling</b>
			1	enable descrambling
5 to 4	SEL_EN[1:0]	R/W	-	LDVS data enable
			00	<b>LVDS data enable = align signal from channel A</b>
			01	LVDS data enable = align signal from channel B
			10	LVDS data enable = 0
			11	LVDS data enable = 1
3	WORD_SWAP	R/W	-	reverse order for LVDS path
			0	<b>normal operation</b>
			1	MSB to LSB order reversed

**Table 60. Register LD\_CNTRL (address 0Ah) ...continued**

Default values are shown highlighted.

Bit	Symbol	Access	Value	Description
2	LDAB_SWAP	R/W		swaps LVDS A and LVDS B paths
			<b>0</b>	<b>normal operation</b>
			1	LVDS A and LVDS B paths are swapped
1	IQ_FORMAT	R/W		specify IQ supplied format
			0	folded
			<b>1</b>	<b>interleaved</b>
0	EDGE_LDCLK	R/W		specify sampling edge for LVDS data path
			0	falling edge of LDCLK
			<b>1</b>	<b>rising edge of LDCLK</b>

**Table 61. Register MISC\_CNTRL (address 0Bh)**

Default values are shown highlighted.

Bit	Symbol	Access	Value	Description
7	SR_CDI	R/W		CDI block software reset control
			<b>0</b>	<b>no action</b>
			1	perform a software reset on CDI
6	RESERVED	R/W	0	reserved
5 to 4	I_LEV_CNTRL[1:0]	R/W		specifies output from CDI for I path
			<b>00</b>	<b>normal operation (CDI data output sent to digital signal processing input)</b>
			01	if LDVS data enable = 1, then normal operation; if LDVS data enable = 0, then digital signal processing input = I_DC_LEVEL register value
			10	digital signal processing input = I_DC_LEVEL
			11	digital signal processing input = I_DC_LEVEL
3 to 2	Q_LEV_CNTRL[1:0]	R/W		specifies output from CDI for Q path
			<b>00</b>	<b>normal operation (CDI data output sent to digital signal processing input)</b>
			01	if LDVS data enable = 1, then normal operation; if LDVS data enable = 0, then digital signal processing input = Q_DC_LEVEL register value
			10	digital signal processing input = Q_DC_LEVEL
			11	digital signal processing input = Q_DC_LEVEL
1 to 0	CDI_MODE[1:0]	R/W		specifies CDI mode
			<b>00</b>	<b>cdi_mode 0 (x2 mode)</b>
			01	cdi_mode 1 (x4 mode)
			10	cdi_mode 2 (x8 mode)
			11	not used

**Table 62. LDS/MDS of I/Q DC levels registers (address 0Ch to 0Fh) bit description***Default values are shown highlighted.*

Address	Register	Bit	Symbol	Access	Value	Description
0Ch	I_DC_LVL_LSB	7 to 0	I_DC_LEVEL[7:0]	R/W	-	I_DC_LEVEL least significant 8 bits for I_DC_LEVEL
0Dh	I_DC_LVL_MSB	7 to 0	I_DC_LEVEL[15:8]		-	most significant 8 bits for I_DC_LEVEL
0Eh	Q_DC_LVL_LSB	7 to 0	Q_DC_LEVEL[7:0]	R/W	-	Q_DC_LEVEL least significant 8 bits for Q_DC_LEVEL
0Fh	Q_DC_LVL_MSB	7 to 0	Q_DC_LEVEL[15:8]		-	most significant 8 bits for Q_DC_LEVEL

**Table 63. Register IO\_MUX0 and IO\_MUX2 (address 10h and 12h)***Default values are shown highlighted.*

IO_SELECT0[9:0]	Signal on pin IO0	Description
00 0000 0000	lclk	internal LVDS lclk clock
00 0000 0001	ringo	internal low frequency oscillator (approximately 1 MHz)
01 0000 nnnn	Ldout_A<nnnn>	internal LVDS data bit of channel A (<nnnn> = 15 to 0; enabling the selection of the bit number to be observed)
10 0000 1111	AND (Ldout_B bits)	AND result of the 16 LVDS data bits of channel B
10 0001 1111	OR (Ldout_B bits)	OR result of the 16 LVDS data bits of channel B
10 0010 1111	AND (Ldout_A bits)	AND result of the 16 LVDS data bits of channel A
10 0011 1111	OR (Ldout_A bits)	OR result of the 16 LVDS data bits of channel A
11 1100 0000	$\overline{\text{INTR}}$	active low interrupt signal
11 1100 0001	INTR	active high interrupt signal
11 1111 1110	1	set the general-purpose IO to high level
<b>11 1111 1111</b>	<b>0</b>	<b>set the general-purpose IO to low level</b>

**Table 64. Register IO\_MUX1 and IO\_MUX2 (address 11h and 12h)**

Default values are shown highlighted.

IO_SELECT1[9:0]	Signal on pin IO1	Description
00 0000 0000	dclk	internal dclk clock ( $f_s / 8$ frequency)
01 0000 nnnn	Ldout_B<nnnn>	internal LVDS data bit of channel B (<nnnn> = 15 to 0; enabling the selection bit number to be observed)
10 0000 1111	AND (Ldout_B bits)	AND result of the 16 LVDS data bits of channel B
10 0001 1111	OR (Ldout_B bits)	OR result of the 16 LVDS data bits of channel B
10 0010 1111	AND (Ldout_A bits)	AND result of the 16 LVDS data bits of channel A
10 0011 1111	OR (Ldout_A bits)	OR result of the 16 LVDS data bits of channel A
11 1100 0000	$\overline{\text{INTR}}$	active low interrupt signal
11 1100 0001	INTR	active high interrupt signal
11 1111 1110	0	set the general-purpose IO to low level
11 1111 1111	1	<b>set the general-purpose IO to high level</b>

**Table 65. Register TYPE\_ID (address 1Bh)**

Default values are shown highlighted.

Bit	Symbol	Access	Value	Description
7	DAC	R		calibration
			0	uncalibrated device
			1	<b>calibrated device</b>
6 to 5	FRONTEND	R	01	<b>LVDS input interface</b>
4	DUAL	R	0	dual DAC
3 to 2	DSP	R		internal digital signal processing
			11	interpolation filter + SSBM
			10	SSBM
			01	interpolation filter
			00	none
1 to 0	BIT_RES	R		DAC bit resolution
			00	<b>16 bits</b>
			01	14 bits
			10	12 bits
			11	10 bits

**Table 66. Register DAC\_VERSION (address 1Ch)***Default values are shown highlighted.*

Bit	Symbol	Access	Value	Description
7 to 0	DAC_VERSION_ID[7:0]	R		DAC version number
			-	8 bits for the DAC version number

**Table 67. Register DIG\_VERSION (address 1Dh)***Default values are shown highlighted.*

Bit	Symbol	Access	Value	Description
7 to 0	DIG_VERSION_ID[7:0]	R		digital version number
			-	8 bits for the digital version number

**Table 68. Register LVDS\_VERSION (address 1Eh)***Default values are shown highlighted.*

Bit	Symbol	Access	Value	Description
7 to 0	LVDS_VERSION_ID[7:0]	R		LVDS receiver version number
			-	8 bits for the LVDS receiver version number

**Table 69. Register PAGE\_ADD (address 1Fh)***Default values are shown highlighted.*

Bit	Symbol	Access	Value	Description
2 to 0	PAGE[2:0]	R/W		Page address
			-	current page address

11. Package outline

HVQFN72: plastic thermal enhanced very thin quad flat package; no leads;  
72 terminals; body 10 x 10 x 0.85 mm

SOT813-3

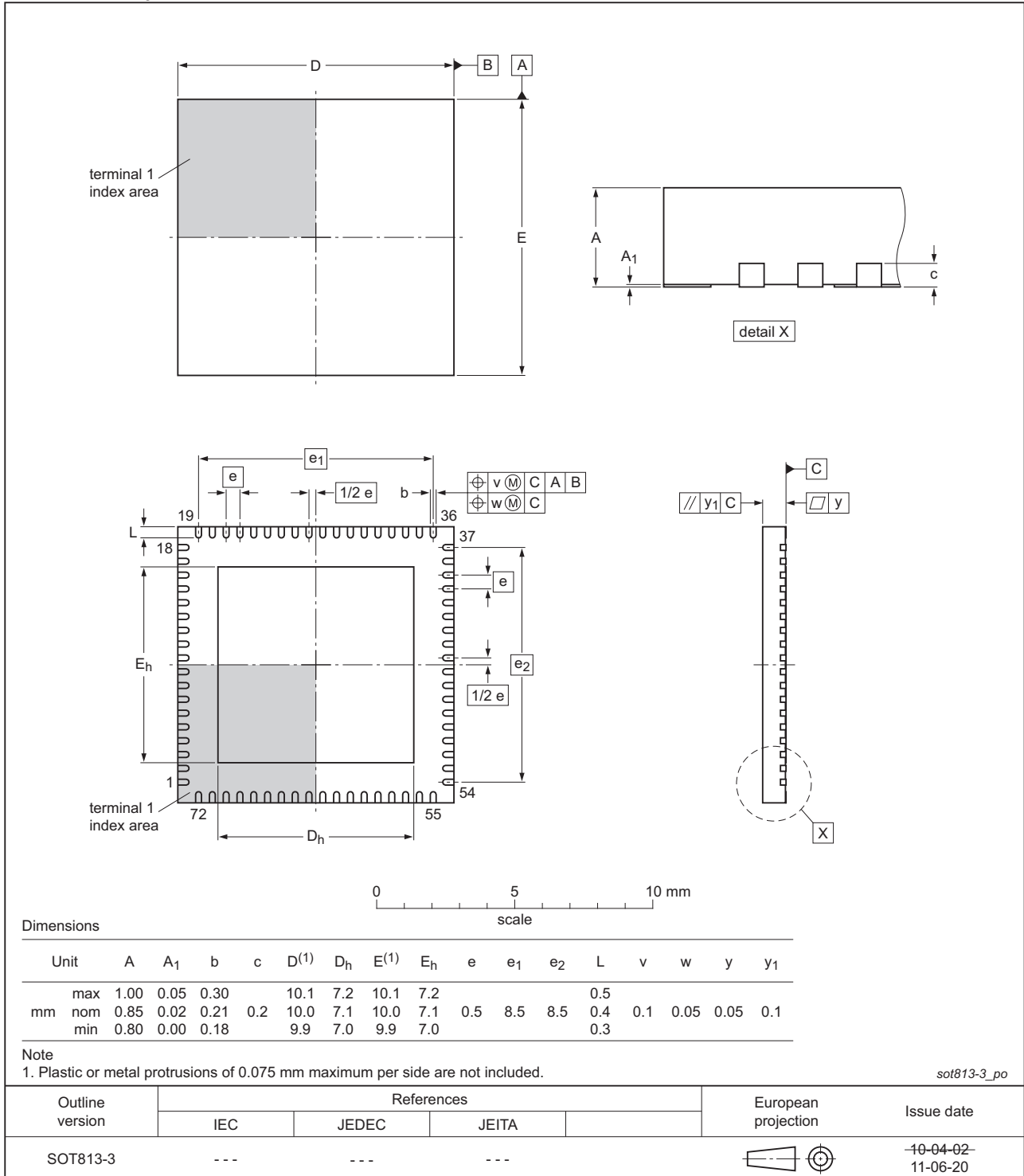

Fig 36. Package outline SOT813-3 (HVQFN72)



## 12. Abbreviations

**Table 70. Abbreviations**

Acronym	Description
BW	BandWidth
BWA	Broadband Wireless Access
CDI	Clock Domain Interface
CDMA	Code Division Multiple Access
CML	Current Mode Logic
CMOS	Complementary Metal Oxide Semiconductor
DAC	Digital-to-Analog Converter
EDGE	Enhanced Data rates for GSM Evolution
FIR	Finite Impulse Response
GSM	Global System for Mobile communications
IF	Intermediate Frequency
IMD3	Third Order InterModulation
LMDS	Local Multipoint Distribution Service
LO	Local Oscillator
LVDS	Low-Voltage Differential Signaling
NCO	Numerically Controlled Oscillator
NMOS	Negative Metal-Oxide Semiconductor
PLL	Phase-Locked Loop
SFDR	Spurious-Free Dynamic Range
SPI	Serial Peripheral Interface
WCDMA	Wide band Code Division Multiple Access
WLL	Wireless Local Loop

## 13. Glossary

---

### 13.1 Static parameters

**INL** — The deviation of the transfer function from a best fit straight line (linear regression computation).

**DNL** — The difference between the ideal and the measured output value between successive DAC codes.

### 13.2 Dynamic parameters

**Spurious-Free Dynamic Range (SFDR)** — The ratio between the RMS value of the reconstructed output sine wave and the RMS value of the largest spurious observed (harmonic and non-harmonic, excluding DC component) in the frequency domain.

**Decibels relative to full scale (dBFS)** — Unit used in a digital system to measure the amplitude level in decibel relative to the maximum peak value.

**InterModulation Distortion (IMD)** — From a dual-tone digital input sine wave (these two frequencies being close together), the intermodulation distortion products IMD2 and IMD3 (second order and third order components) are defined below.

**IMD2** — The ratio between the RMS value of either tone and the RMS value of the worst second order Intermodulation product.

**IMD3** — The ratio between the RMS value of either tone and the RMS value of the worst third order Intermodulation product.

**Total Harmonic Distortion (THD)** — The ratio between the RMS value of the harmonics of the output frequency and the RMS value of the output sine wave. Usually, the calculation of THD is done on the first 5 harmonics.

**Signal-to-Noise Ratio (SNR)** — The ratio between the RMS value of the reconstructed output sine wave and the RMS value of the noise excluding the harmonics and the DC component.

**Restricted BandWidth Spurious-Free Dynamic Range (SFDR<sub>RBW</sub>)** — The ratio between the RMS value of the reconstructed output sine wave and the RMS value of the noise, including the harmonics, in a given bandwidth centered around  $f_{\text{offset}}$ .

## 14. Revision history

Table 71. Revision history

Document ID	Release date	Data sheet status	Change notice	Supersedes
DAC1617D1G0 v.4	20120720	Product data sheet	-	DAC1716D1G0 v.3
DAC1617D1G0 v.3	20120702	Rebranded/updated	-	DAC1617D1G0 v.2
DAC1617D1G0 v.2	20120630	Preliminary data sheet	-	DAC1617D1G0 v.1.1
DAC1617D1G0 v.1.1	20110930	Objective data sheet	-	DAC1617D1G0 v.1
DAC1617D1G0 v.1	20110906	Objective data sheet	-	-

## Contact information



[www.IDT.com](http://www.IDT.com)

6024 Silver Creek Valley Road  
San Jose, California 95138

**15. Tables**

Table 1. Ordering information . . . . .	2	Table 37. MDS window time registers (address 01h to 02h) bit description . . . . .	56
Table 2. Pin description . . . . .	4	Table 38. MDS_MISCCNTRL0 register (address 03h) bit description . . . . .	56
Table 3. Limiting values . . . . .	7	Table 39. MDS_MAN_ADJUSTDLY register (address 04h) bit description . . . . .	57
Table 4. Thermal characteristics . . . . .	7	Table 40. MDS_AUTO_CYCLES register (address 05h) bit description . . . . .	57
Table 5. Characteristics . . . . .	8	Table 41. MDS_MISCCNTRL1 register (address 06h) bit description . . . . .	57
Table 6. Read or Write mode access description . . . . .	15	Table 42. MDS_OFFSET_DLY register (address 07h) bit description . . . . .	58
Table 7. Number of bytes transferred . . . . .	15	Table 43. MDS_ADJDELAY register (address 08h) bit description . . . . .	58
Table 8. SPI timing characteristics . . . . .	16	Table 44. MDS status registers (address 09h to 0Ah) bit description . . . . .	58
Table 9. Input LVDS bus swapping . . . . .	18	Table 45. Interrupt control register (address 0Bh) bit description . . . . .	59
Table 10. Folded and interleaved format mapping . . . . .	19	Table 46. Interrupt enable register (address 0Ch) bit description . . . . .	60
Table 11. CDI mode 0: operating modes examples . . . . .	24	Table 47. INTR_FLAGS register (address 0Dh) bit description . . . . .	60
Table 12. CDI mode 1: operating modes examples . . . . .	25	Table 48. Bias current control registers (address 0Eh to 15h) bit description . . . . .	61
Table 13. CDI mode 2: operating modes examples . . . . .	25	Table 49. Bias current control table . . . . .	61
Table 14. Interpolation filter coefficients . . . . .	27	Table 50. DAC_PON_SLEEP register (address 16h) bit description . . . . .	62
Table 15. Complex modulator operation mode . . . . .	30	Table 51. DAC_TEST_8 register (address 17h) bit description . . . . .	62
Table 16. Inversion filter coefficients . . . . .	30	Table 52. SPI_PAGE register (address 1Fh) bit description . . . . .	63
Table 17. DAC transfer function . . . . .	35	Table 53. Page_0A register allocation map . . . . .	64
Table 18. Digital offset adjustment . . . . .	37	Table 54. Register MAIN_CNTRL (address 00h) . . . . .	66
Table 19. Auxiliary DAC transfer function . . . . .	39	Table 55. Register MAN_LDCLKDEL (address 01h) . . . . .	66
Table 20. SPI start-up sequence . . . . .	45	Table 56. Register DBG_LVDS (address 02h) . . . . .	66
Table 21. Page_00 register allocation map . . . . .	47	Table 57. Extension time reset registers (address 04h to 05h) bit description . . . . .	67
Table 22. Register COMMON (address 00h) bit description . . . . .	49	Table 58. Register DCSMU_PREDIV (address 06h) . . . . .	67
Table 23. Register TXCFG (address 01h) bit description . . . . .	49	Table 59. LSB/MSB of polarity registers (address 08h to 09h) bit description . . . . .	67
Table 24. Register PLLCFG (address 02h) bit description . . . . .	50	Table 60. Register LD_CNTRL (address 0Ah) . . . . .	67
Table 25. NCO frequency registers (address 04h to 08h) bit description . . . . .	50	Table 61. Register MISC_CNTRL (address 0Bh) . . . . .	68
Table 26. DAC output phase correction registers (address 09h to 0Ah) bit description . . . . .	51	Table 62. LDS/MDS of I/Q DC levels registers (address 0Ch to 0Fh) bit description . . . . .	69
Table 27. Digital gain control registers (address 0Bh to 0Eh) bit description . . . . .	51	Table 63. Register IO_MUX0 and IO_MUX2 (address 10h and 12h) . . . . .	69
Table 28. Register DAC_OUT_CTRL (address 0Fh) . . . . .	51	Table 64. Register IO_MUX1 and IO_MUX2 (address 11h and 12h) . . . . .	70
Table 29. Register DAC_CLIPPING (address 10h) . . . . .	52		
Table 30. Digital offset value registers (address 11h to 14h) bit description . . . . .	52		
Table 31. NCO phase offset registers (address 15h to 16h) bit description . . . . .	52		
Table 32. Analog gain control registers (address 17h to 1Ah) bit description . . . . .	53		
Table 33. Auxiliary DAC registers (address 1Bh to 1Eh) bit description . . . . .	53		
Table 34. SPI_PAGE register (address 1Fh) bit description . . . . .	53		
Table 35. Page 1 register allocation map . . . . .	54		
Table 36. MDS_MAIN register (address 00h) bit description . . . . .	56		

continued >>

Table 65. Register TYPE\_ID (address 1Bh) .....70  
Table 66. Register DAC\_VERSION (address 1Ch) .....71  
Table 67. Register DIG\_VERSION (address 1Dh) .....71  
Table 68. Register LVDS\_VERSION (address 1Eh) .....71  
Table 69. Register PAGE\_ADD (address 1Fh) .....71  
Table 70. Abbreviations .....73  
Table 71. Revision history .....75

16. Contents

<b>1</b>	<b>General description</b> . . . . .	<b>1</b>	10.12	Inverse (sin x) / x . . . . .	30
<b>2</b>	<b>Features and benefits</b> . . . . .	<b>2</b>	10.13	Multiple Devices Synchronization (MDS) . . . . .	31
<b>3</b>	<b>Applications</b> . . . . .	<b>2</b>	10.13.1	MDS concept . . . . .	31
<b>4</b>	<b>Ordering information</b> . . . . .	<b>2</b>	10.13.1.1	MDS in All slaves mode . . . . .	33
<b>5</b>	<b>Block diagram</b> . . . . .	<b>3</b>	10.13.1.2	MDS in Master/slaves mode . . . . .	34
<b>6</b>	<b>Pinning information</b> . . . . .	<b>4</b>	10.13.2	MDS flexibility and constraints . . . . .	34
6.1	Pinning . . . . .	4	10.14	DAC transfer function . . . . .	35
6.2	Pin description . . . . .	4	10.15	Full-scale current . . . . .	36
<b>7</b>	<b>Limiting values</b> . . . . .	<b>7</b>	10.15.1	Regulation . . . . .	36
<b>8</b>	<b>Thermal characteristics</b> . . . . .	<b>7</b>	10.15.2	Full-scale current adjustment . . . . .	36
<b>9</b>	<b>Characteristics</b> . . . . .	<b>8</b>	10.16	Limiter/clip control . . . . .	37
<b>10</b>	<b>Application information</b> . . . . .	<b>14</b>	10.17	Digital offset adjustment . . . . .	37
10.1	General description . . . . .	14	10.18	Analog output . . . . .	37
10.2	Serial Peripheral Interface (SPI) . . . . .	14	10.19	Auxiliary DACs . . . . .	38
10.2.1	Protocol description . . . . .	14	10.20	Output configuration . . . . .	39
10.2.2	SPI timing description . . . . .	16	10.20.1	Basic output configuration . . . . .	40
10.3	Power-on sequence . . . . .	16	10.20.2	Low input impedance IQ-modulator interface . . . . .	41
10.4	LVDS Data Input Format (DIF) block . . . . .	17	10.20.3	IQ-modulator - DC interface . . . . .	41
10.4.1	Input port polarity . . . . .	17	10.20.4	IQ-modulator - AC interface . . . . .	44
10.4.2	Input port mapping . . . . .	17	10.21	Design recommendations . . . . .	44
10.4.3	Input port swapping . . . . .	18	10.21.1	Power and grounding . . . . .	44
10.4.4	Input port formatting . . . . .	19	10.22	Configuration interface . . . . .	45
10.4.5	Data parity/data enable . . . . .	20	10.22.1	Register description . . . . .	45
10.5	Interrupt controller . . . . .	20	10.22.2	SPI start-up sequence . . . . .	45
10.6	General-purpose IO pins . . . . .	20	10.22.3	Page 0 register allocation map . . . . .	47
10.7	Input clock . . . . .	20	10.22.4	Page 0 bit definition detailed description . . . . .	49
10.7.1	LVDS DDR clock . . . . .	20	10.22.5	Page 1 allocation map . . . . .	54
10.7.2	DAC core clock . . . . .	21	10.22.6	Page 1 bit definition detailed description . . . . .	56
10.8	Timing . . . . .	22	10.22.7	Page A register allocation map . . . . .	64
10.9	Operating modes . . . . .	23	10.22.8	Page A bit definition detailed description . . . . .	66
10.9.1	CDI mode 0 (x2 interpolation) . . . . .	24	<b>11</b>	<b>Package outline</b> . . . . .	<b>72</b>
10.9.2	CDI mode 1 (x4 interpolation) . . . . .	25	<b>12</b>	<b>Abbreviations</b> . . . . .	<b>73</b>
10.9.3	CDI mode 2 (x8 interpolation) . . . . .	25	<b>13</b>	<b>Glossary</b> . . . . .	<b>74</b>
10.10	FIR filters . . . . .	26	13.1	Static parameters . . . . .	74
10.11	Single SideBand Modulator (SSBM) . . . . .	28	13.2	Dynamic parameters . . . . .	74
10.11.1	NCO in 40 bits . . . . .	29	<b>14</b>	<b>Revision history</b> . . . . .	<b>75</b>
10.11.2	NCO low power . . . . .	29	<b>15</b>	<b>Tables</b> . . . . .	<b>76</b>
10.11.3	Complex modulator . . . . .	29	<b>16</b>	<b>Contents</b> . . . . .	<b>78</b>
10.11.4	Minus 3dB . . . . .	30			

Disclaimer

Integrated Device Technology, Inc. (IDT) and its subsidiaries reserve the right to modify the products and/or specifications described herein at any time and at IDT's sole discretion. All information in this document, including descriptions of product features and performance, is subject to change without notice. Performance specifications and the operating parameters of the described products are determined in the independent state and are not guaranteed to perform the same way when installed in customer products. The information contained herein is provided without representation or warranty of any kind, whether express or implied, including, but not limited to, the suitability of IDT's products for any particular purpose, an implied warranty of merchantability, or non-infringement of the intellectual property rights of others. This document is presented only as a guide and does not convey any license under intellectual property rights of IDT or any third parties.

IDT's products are not intended for use in life support systems or similar devices where the failure or malfunction of an IDT product can be reasonably expected to significantly affect the health or safety of users. Anyone using an IDT product in such a manner does so at their own risk, absent an express, written agreement by IDT.

Integrated Device Technology, IDT and the IDT logo are registered trademarks of IDT. Other trademarks and service marks used herein, including protected names, logos and designs, are the property of IDT or their respective third party owners.

Copyright, 2012. All rights reserved.