

EL4332

Triple 2:1 300MHz Mux-Amp AV = 2

FN7163
Rev 2.00
October 4, 2004

The EL4332 is a triple very high speed 2:1 Multiplexer-Amplifier. It is intended primarily for component video multiplexing and is especially suited for pixel switching. The amplifiers have their gain set to 2 internally, which reduces the need for many external components. The gain-of-2 facilitates driving back terminated cables. All three amplifiers are switched simultaneously from their A to B inputs by the TTL/CMOS compatible, common A/B control pin.

A -3dB bandwidth of 300MHz together with 3ns multiplexing time enable the full performance of the fastest component video systems to be realized.

The EL4332 runs from standard $\pm 5V$ supplies, and is available in the narrow 16-pin small outline package.

Pinout

EL4332
[16-PIN SO (0.150")]
TOP VIEW

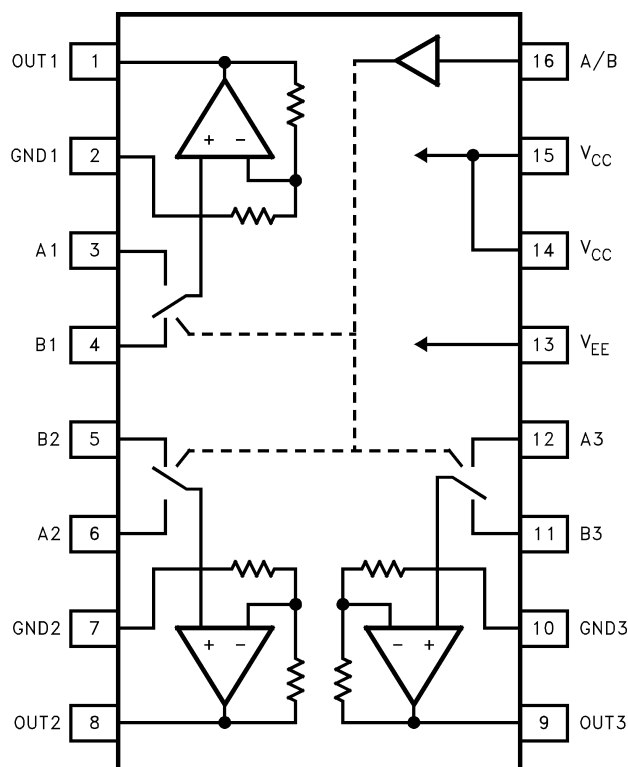

Features

- 3ns A-B switching
- 300MHz bandwidth
- Fixed gain of 2, for cable driving
- > 650V/ μ s slew rate
- TTL/CMOS compatible switch
- Pb-free available

Applications

- RGB multiplexing
- Picture-in-picture
- Cable driving
- HDTV processing
- Switched gain amplifiers
- ADC input multiplexer

Ordering Information

PART NUMBER	PACKAGE	TAPE & REEL	PKG. DWG. #
EL4332CS	16-Pin SO (0.150")	-	MDP0027
EL4332CS-T7	16-Pin SO (0.150")	7"	MDP0027
EL4332CS-T13	16-Pin SO (0.150")	13"	MDP0027
EL4332CSZ (Note)	16-Pin SO (0.150") (Pb-Free)	-	MDP0027
EL4332CSZ-T7 (Note)	16-Pin SO (0.150") (Pb-Free)	7"	MDP0027
EL4332CSZ-T13 (Note)	16-Pin SO (0.150") (Pb-Free)	13"	MDP0027

NOTE: Intersil Pb-free products employ special Pb-free material sets; molding compounds/die attach materials and 100% matte tin plate termination finish, which is compatible with both SnPb and Pb-free soldering operations. Intersil Pb-free products are MSL classified at Pb-free peak reflow temperatures that meet or exceed the Pb-free requirements of IPC/JEDEC J Std-020B.

Demo Board

A demo PCB is available for this product.

Absolute Maximum Ratings ($T_A = 25^\circ\text{C}$)

V_{CC} to V_{EE}	14V	Input Current, Any Input	5mA
V_{CC} to any GND	12V	Power Dissipation	See Curves
V_{EE} to any GND	12V	Ambient Operating Temperature	-40°C to 85°C
Continuous Output Current	45mA	Junction Temperature	150°C
Any Input	$V_{EE} - 0.3\text{V}$ to $V_{CC} + 0.3\text{V}$	Storage Temperature	-60°C to $+150^\circ\text{C}$

CAUTION: Stresses above those listed in "Absolute Maximum Ratings" may cause permanent damage to the device. This is a stress only rating and operation of the device at these or any other conditions above those indicated in the operational sections of this specification is not implied.

IMPORTANT NOTE: All parameters having Min/Max specifications are guaranteed. Typical values are for information purposes only. Unless otherwise noted, all tests are at the specified temperature and are pulsed tests, therefore: $T_J = T_C = T_A$

DC Electrical Specifications $V_{CC} = +5\text{V}$, $V_{EE} = -5\text{V}$, Temperature = 25°C , $R_L = \infty$

PARAMETER	DESCRIPTION	MIN	TYP	MAX	UNITS
V_{OS}	Input Referred Offset Voltage		8	20	mV
dV_{OS}	Input Referred Offset Voltage Delta (Note 1)		2	8	mV
R_{IN}	Input Resistance		30		$k\Omega$
I_B	Input Bias Current		-7	-30	μA
dI_B	Input Bias Current Delta (Note 1)		0.5	4.0	μA
A_V	Gain	1.94	2.00	2.06	V/V
dA_V	Gain Delta (Note 1)		0.5	2.5	%
C_{IN}	Input Capacitance		3.3		pF
PSRR	Power Supply Rejection Ratio	50	70		dB
V_O	Output Voltage Swing into 500Ω load	± 2.7	± 3.6		V
	Output Voltage Swing into 150Ω load		+3/-2.7		V
I_{OUT}	Current Output, Measured with 75Ω Load (Note 2)	30	40		mA
X_{talk}_{AB}	Crosstalk from Non-selected Input (at DC)	-70	-100		dB
X_{talk}_{CH-CH}	Crosstalk from one Amplifier to another Amplifier	-70	-100		dB
V_{IH}	Input Logic High Level	2.0			V
V_{IL}	Input Logic Low Level			0.8	V
I_{IL}	Logic Low Input Current ($V_{IN} = 0\text{V}$)	-0.3	-40	-80	μA
I_{IH}	Logic High Input Current ($V_{IN} = 0\text{V}$)	-3	0	3	μA
I_S	Total Supply Current	38	48	60	mA

NOTES:

- Each channel's A-input to its B-input.
- There is no short circuit protection on any output.

AC Electrical Specifications $V_{CC} = +5\text{V}$, $V_{EE} = -5\text{V}$, Temperature = 25°C , $R_L = 150\Omega$, $C_L = 3\text{pF}$.

PARAMETER	DESCRIPTION	MIN	TYP	MAX	UNITS
BW	-3dB Bandwidth		300		MHz
BW 0.1dB	$\pm 0.1\text{dB}$ Bandwidth		105		MHz
DG	Differential Gain at 3.58MHz		0.04		%
DP	Differential Phase at 3.58MHz		0.08		$^\circ$
Pkg	Peaking with Nominal Load		0.2		dB
SR	Slew Rate (4V Square Wave, Measured 25%–75%)		650		V/ μs

AC Electrical Specifications $V_{CC} = +5V$, $V_{EE} = -5V$, Temperature = 25°C, $R_L = 150\Omega$, $C_L = 3pF$. (Continued)

PARAMETER		DESCRIPTION	MIN	TYP	MAX	UNITS
t_s		Settling Time to 0.1% of Final Value		13		ns
T_{SW}		Time to Switch Inputs		3		ns
OS		Overshoot, $V_{OUT} = 4V_{P-P}$		8		%
I_{SOab}	10M	Input to Input Isolation at 10MHz		60		dB
	100M	Input to Input Isolation at 100MHz		40		dB
$I_{SOch-ch}$	10M	Channel to Channel Isolation at 10MHz		61		dB
	100M	Channel to Channel Isolation at 100MHz		50		dB

Pin Descriptions

PIN NAME	FUNCTION
A1, A2, A3	“A” inputs to amplifiers 1, 2 and 3 respectively.
B1, B2, B3	“B” inputs to amplifiers 1, 2 and 3 respectively.
GND1, GND2, GND3	These are the individual ground pins for each channel.
Out1, Out2, Out3	Amplifier outputs. Note: there is no short circuit protection on any output.
V_{CC}	Positive power supply. Typically +5V.
V_{EE}	Negative power supply. Typically -5V.
A/B	Common input select pin, a logic high selects the “A” inputs, logic low selects the “B” inputs. CMOS/TTL compatible.

Burn In Schematic

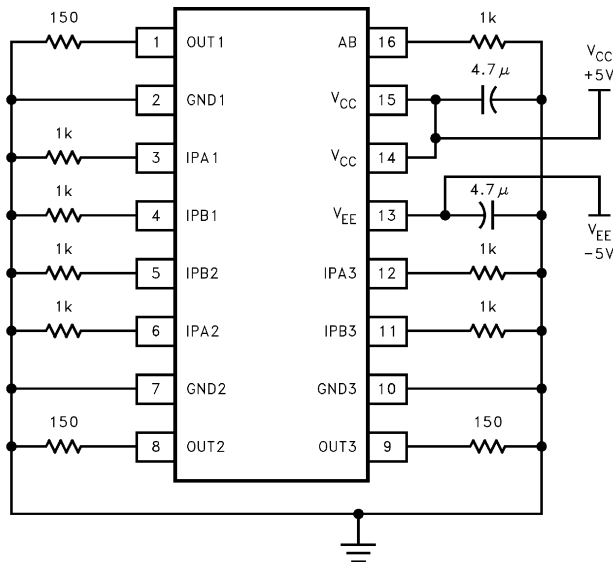

Typical Performance Curves

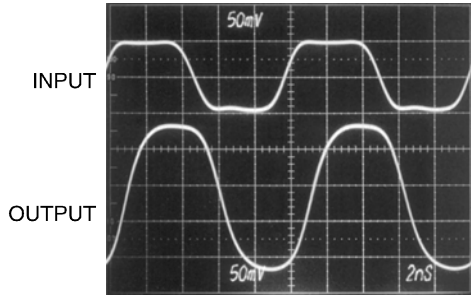

FIGURE 1. SMALL SIGNAL TRANSIENT RESPONSE

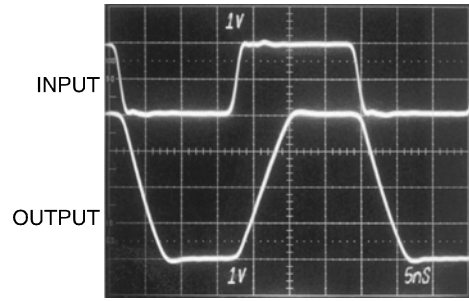

FIGURE 2. LARGE SIGNAL TRANSIENT RESPONSE

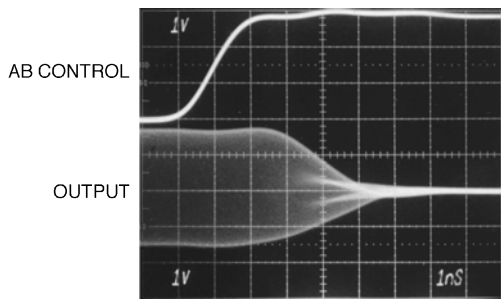

FIGURE 3. SWITCHING TO GROUND FROM A LARGE SIGNAL UNCORRELATED SINE WAVE

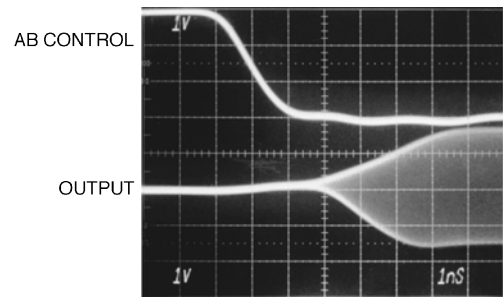

FIGURE 4. SWITCHING FROM GROUND TO A LARGE SIGNAL UNCORRELATED SINE WAVE

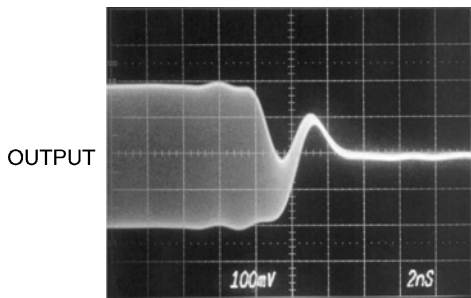

FIGURE 5. SWITCHING TO GROUND FROM A SMALL SIGNAL UNCORRELATED SINE WAVE

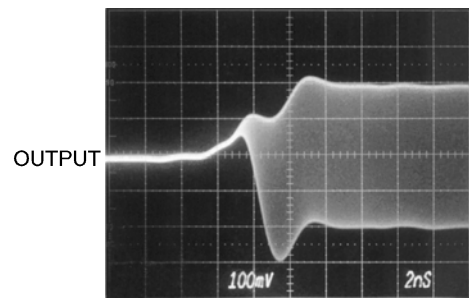

FIGURE 6. SWITCHING FROM GROUND TO A SMALL SIGNAL UNCORRELATED SINE WAVE

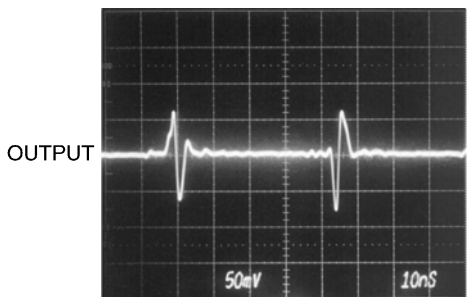

FIGURE 7. SWITCHING GLITCH (INPUTS AT GROUND)

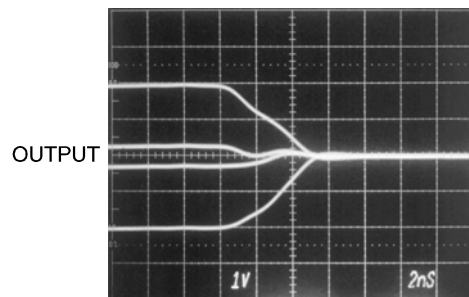

FIGURE 8. SWITCHING FROM A FAMILY OF DC LEVELS TO GROUND

Typical Performance Curves (Continued)

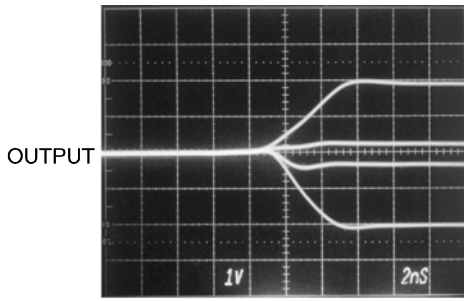

FIGURE 9. SWITCHING FROM GROUND TO A FAMILY OF DC LEVELS

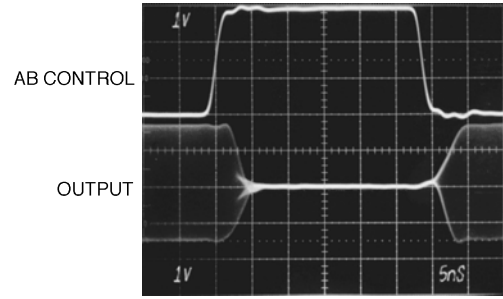

FIGURE 10. CHANNEL A/B SWITCHING DELAY

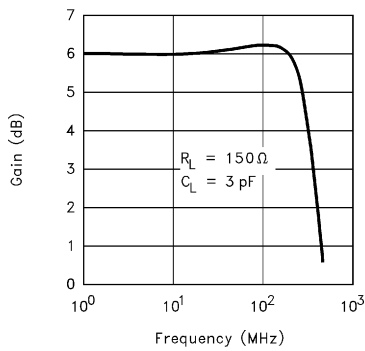

FIGURE 11. GAIN vs FREQUENCY

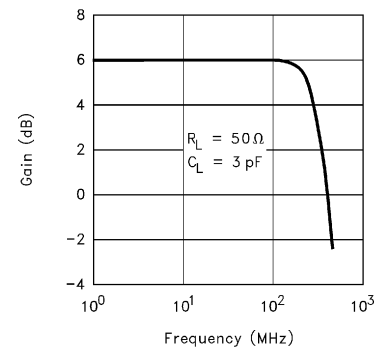

FIGURE 12. GAIN vs FREQUENCY

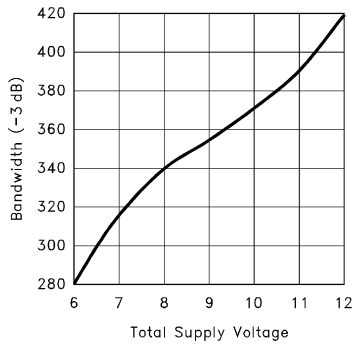

FIGURE 13. -3dB BW vs SUPPLY VOLTAGE

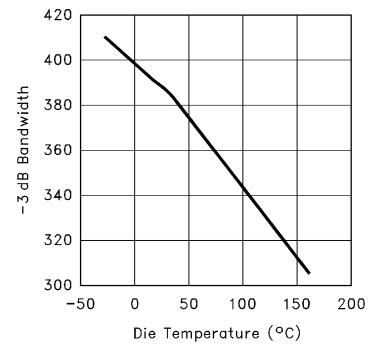

FIGURE 14. BANDWIDTH vs DIE TEMPERATURE

Typical Performance Curves (Continued)

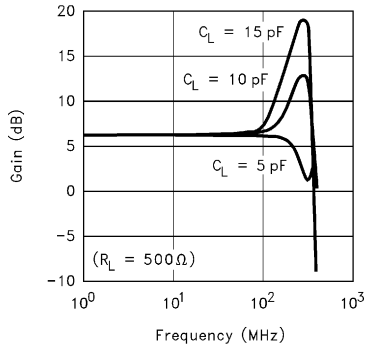

FIGURE 15. FREQUENCY RESPONSE WITH CAPACITIVE LOADS

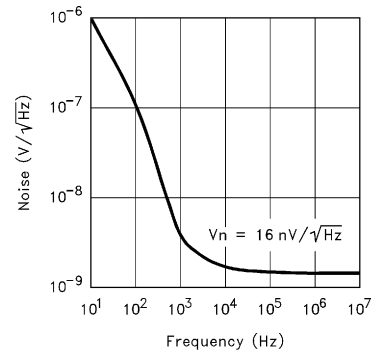

FIGURE 16. INPUT VOLTAGE NOISE OVER FREQUENCY

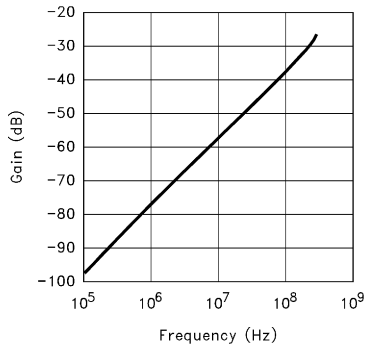

FIGURE 17. A-INPUT TO B-INPUT ISOLATION

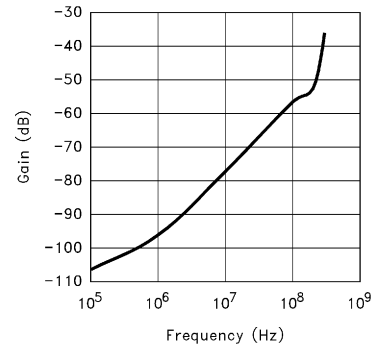

FIGURE 18. CHANNEL-CHANNEL ISOLATION

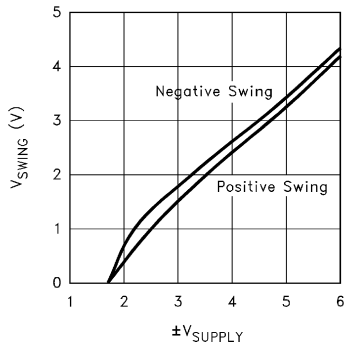

FIGURE 19. OUTPUT SWING vs SUPPLY VOLTAGE

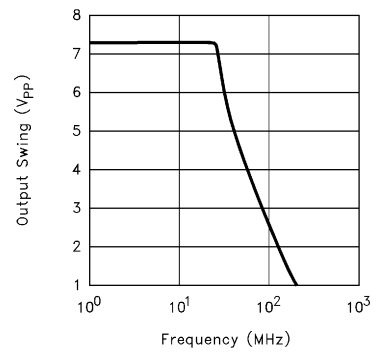

FIGURE 20. OUTPUT SWING vs FREQUENCY

Typical Performance Curves (Continued)

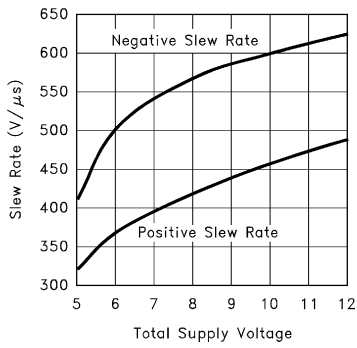

FIGURE 21. SLEW RATE vs SUPPLY VOLTAGE

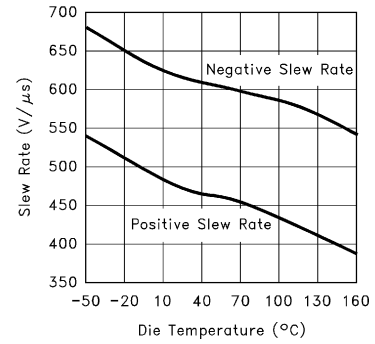

FIGURE 22. SLEW RATE vs DIE TEMPERATURE

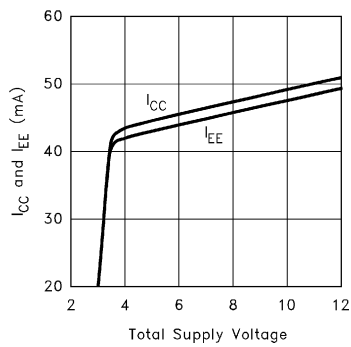

FIGURE 23. SUPPLY CURRENT vs SUPPLY VOLTAGE

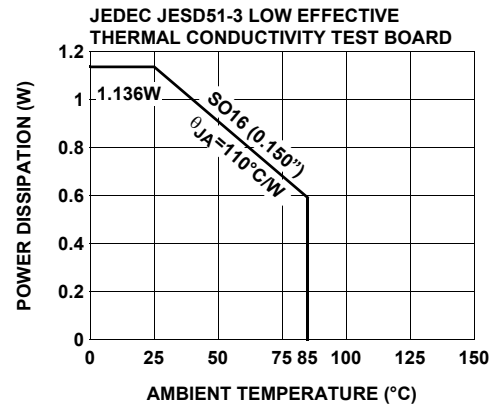

FIGURE 24. POWER DISSIPATION vs AMBIENT TEMPERATURE

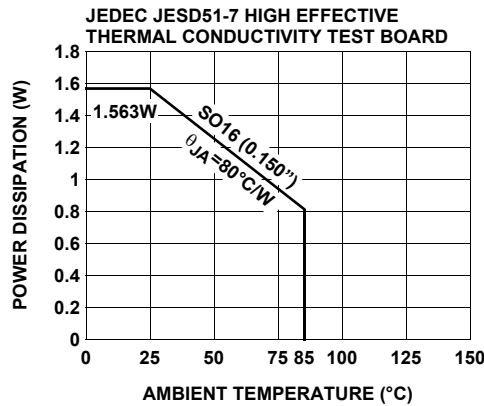

FIGURE 25. POWER DISSIPATION vs AMBIENT TEMPERATURE

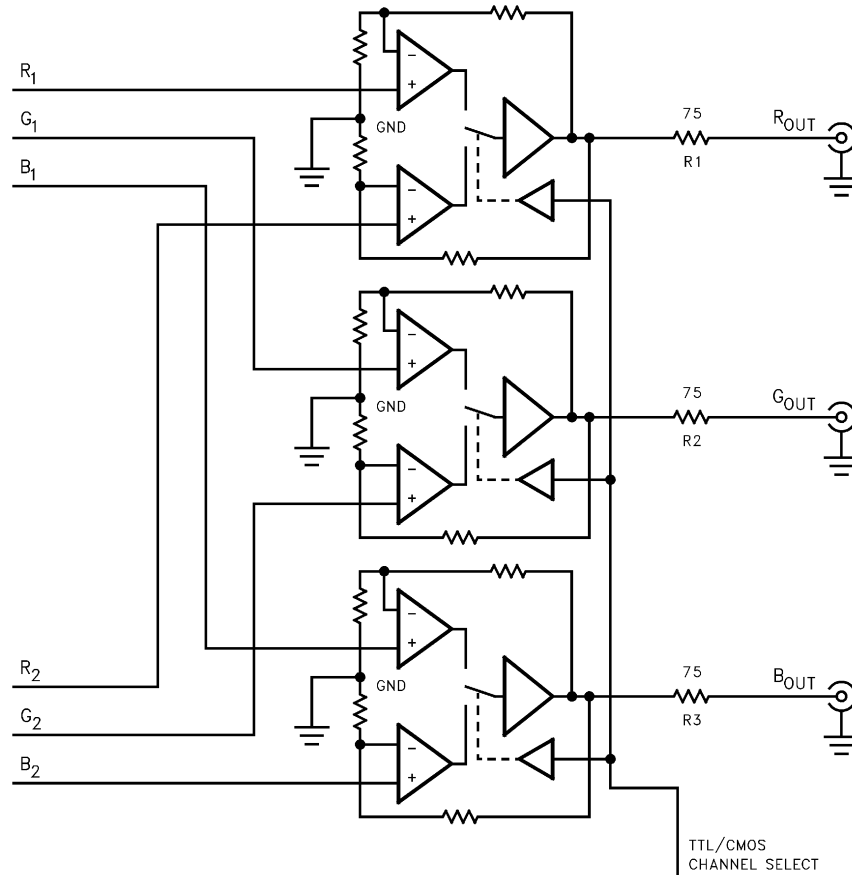

FIGURE 26. TYPICAL CONNECTION FOR A 2:1 COMPONENT VIDEO MULTIPLEXER

Applications Information

Figure 26 shows a typical use for the EL4332. The circuit is a component video (R,G, B or Y,U,V) multiplexer. Since the gain of the internal amplifiers has been set to 2, the only extra components needed are the supply decoupling capacitors and the back terminating resistors, if transmission lines are to be driven. The EL4332 can drive backmatched 50Ω or 75Ω loads.

Grounds

It will be noticed that each mux-amp channel has its own separate ground pin. These ground pins have been kept separate to keep the channel separation inside the chip as large as possible. The feedback resistors use these ground pins as their reference. The resistors total 400Ω, so there is a significant signal current flowing from these pins to ground.

The ground pins should all be connected together, to a ground plane underneath the chip. 1 oz. copper for the ground plane is highly recommended.

Further notes and recommended practices for high speed printed circuit board layout can be found in the tutorials in the Elantec databooks.

Supplies

Supply bypassing should be as physically near the power pins as possible. Chip capacitors should be used to minimize lead inductance. Note that larger values of capacitor tend to have larger internal inductances. So when designing for 3 transmission lines or similar moderate loads, a 0.1μF ceramic capacitor right next to the power pin in parallel with a 22μF tantalum capacitor placed as close to the 0.1μF is recommended. For lighter loadings, or if not all the channels are being used, a single 4.7μF capacitor has been found quite adequate.

Note that component video signals do tend to have a high level of signal correlation. This is especially true if the video signal has been derived from 3 synchronously clocked DACs. This corresponds to all three channels drawing large slew currents simultaneously from the supplies. Thus, proper bypassing is critical.

Logic Inputs

The A/B select, logic input, is internally referenced to ground. It is set at 2 diode drops above ground, to give a threshold of about 1.4V (see Figure 27). The PNP input transistor requires that the driving gate be able to sink current, typically <math>< 30\mu A</math>, for a logic “low”. If left to float, it will be a logic “high”.

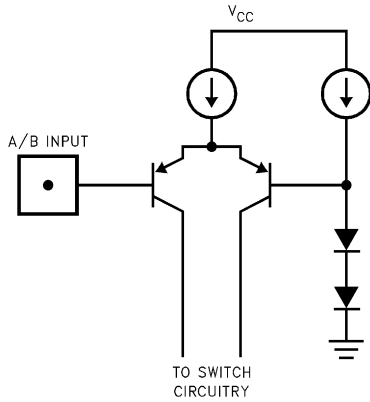

FIGURE 27. SIMPLIFIED LOGIC INPUT STAGE

The input PNP transistors have sufficient gain that a simple level shift circuit (see Figure 28) can be used to provide a simple interface with Emitter Coupled Logic. Typically, 200mV is enough to switch from a solid logic “low” to a “high.”

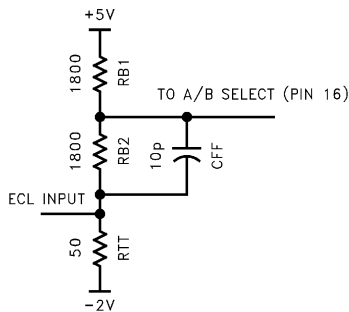

FIGURE 28. ADAPTING THE SELECT PIN FOR ECL LOGIC LEVELS

The capacitor C_{FF} is only in the network to prevent the A/B pin’s capacitance from slowing the control signal. The network shown level shifts the ECL levels, -0.7V to -1.5V to +1.6V and +1.1V respectively. The terminating resistor, R_{TT} , is required since the open emitter of the ECL gate can not sink current. If a -2V rail is not being used, a 220 Ω to 330 Ω resistor to the -5.2V rail would have the same effect.

Expanding the Multiplexer

In Figure 29, a 3:1 multiplexer circuit is shown. The expansion to more inputs is very straight forward. Since the EL4332 has a fixed gain of 2, interstage attenuators may be required as shown in Figure 28. The truth table for the 3:1 multiplexer select lines is:

TABLE 1.

X	Y	MUX OUTPUT
0	0	R3, G3, B3
0	1	R2, G2, B2
1	X	R1, G1, B1

When interstage attenuators are used, the values should be kept down in the region of 50Ω–300Ω. This is to prevent a combination of circuit board stray capacitance and the EL4332's input capacitance forming a significant pole. For example, if instead of 100Ω as shown, resistors of 1kΩ had been used, and assuming 3pF of stray and 3pF of input capacitance, a pole would be formed at about 53MHz.

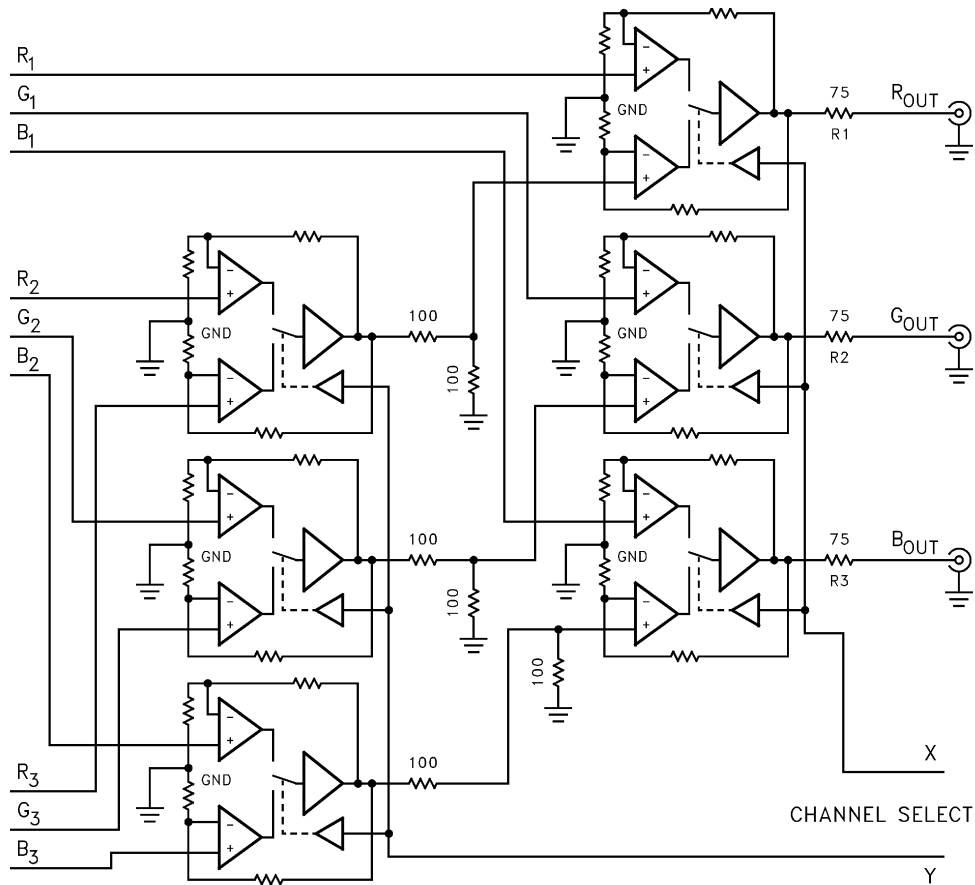

FIGURE 29. TYPICAL CONNECTION FOR A 3:1 COMPONENT VIDEO MULTIPLEXER

A Bandwidth Selectable Circuit

In Figure 30, a circuit is shown that allows three signals to be either low pass filtered or full bandwidth.

This could be useful where an input signal is frequently noisy. The component values shown give a Butterworth LPF response, with a -3dB frequency of 50MHz. Note again, the resistor values are low, so that stray capacitance does not affect the desired cut-off frequency.

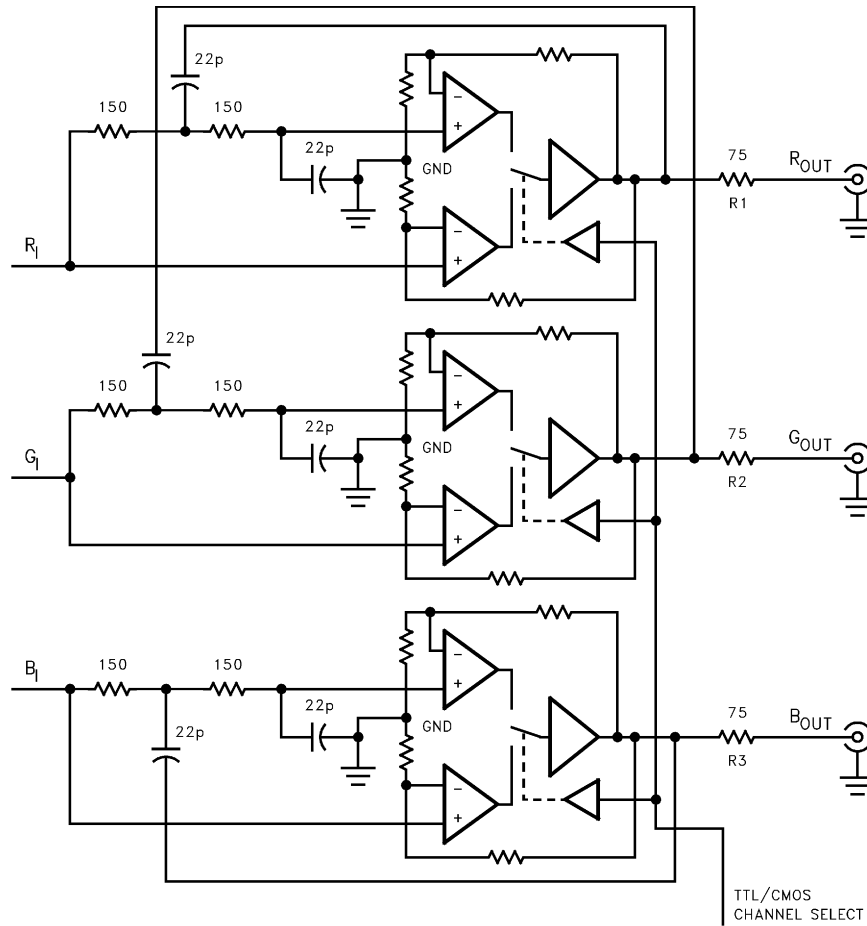

FIGURE 30. SWITCHED 50MHz LOW PASS FILTER FOR HIGH/LOW RESOLUTION MONITORS

R51 105 13 275
 R61 106 13 275
 R71 1 114 400
 R81 114 2 400
 R911 117 400
 R110 117 2 400
 Ediff1 108 0 value $\{(v(104,103)*v(107))+v(106,105)*(1-v(107))\}$
 rdiff1 108 0 1K

* Compensation Section

ga1 0 134 108 0 1m
 rh1 134 0 5 Meg
 cc1 134 0 0.6 pF

* Poles

ep1 141 0 134 0 1.0
 rpa1 141 142 200
 cpa1 142 0 0.75 pF
 rpb1 142 143 200
 cpb1 143 0 0.75 pF

* Output Stage

i011 15 150 1.0 mA
 i021 151 13 1.0 mA
 q71 13 143 150 qp
 q81 15 143 151 qn
 q91 15 150 152 qn
 q101 13 151 153 qp
 ros11 152 1 2
 ros21 153 1 2

***** Amplifier #2*****

q231 203 6 212 qp
 q241 204 214 213 qp
 q251 205 5 215 qp
 q261 206 217 216 qp
 la12 14 212 1 mA
 la22 14 213 1 mA
 lb12 14 215 1 mA
 lb22 14 216 1 mA
 Rga2 212 213 275
 Rgb2 215 216 275
 R231 203 13 275
 R241 204 13 275
 R251 205 13 275
 R261 206 13 275
 R271 8 214 400
 R281 214 7 400
 R291 8 217 400
 R210 217 7 400
 Ediff2 208 0 value $\{(v(204,203)*v(107))+v(206,205)*(1-v(107))\}$
 rdiff2 208 0 1K

* Compensation Section

ga2 0 234 208 0 1m
 rh2 234 0 5 Meg
 cc2 234 0 0.6 pF

*

* Poles

*

ep2 241 0 234 0 1.0
 rpa2 241 242 200
 cpa2 242 0 0.75 pF
 rpb2 242 243 200
 cpb2 243 0 0.75 pF

*

*Output Stage

*

i0 12 15 250 1.0 mA
 i022 251 13 1.0 mA
 q271 13 243 250 qp
 q281 15 243 251 qn
 q291 15 250 252 qn
 q201 13 251 253 qp
 ros12 252 8 2
 ros22 253 8 2

*

*****Amplifier #3 *****

q331 303 12 312 qp
 q341 304 314 313 qp
 q351 305 11 315 qp
 q361 306 317 316 qp
 la13 14 312 1 mA
 la23 14 313 1 mA
 lb13 14 315 1 mA
 lb23 14 316 1 mA
 Rga3 312 313 275
 Rgb3 315 316 275
 R331 303 13 275
 R341 304 13 275
 R351 305 13 275
 R361 306 13 275
 R371 9 314 400
 R381 314 10 400
 R391 9 317 400
 R310 317 10 400
 Ediff3 308 0 value {{ v(304,303)*(v(107))+v(306,305)*(1-v(107))}}
 rdiff3 308 0 1K

*

* Compensation

*

ga3 0 334 308 01m
 rh3 334 0 5 Meg
 cc3 334 0 0.6 pF

*

* Poles

*

ep3 341 0 3340 1.0
 rpa3 341 342 200
 cpa3 342 0 0.75 pF
 rpb3 342 343 200
 cpb3 343 0 0.75 pF

*

* Output Stage

*

i013 15 350 1.0 mA
 i023 351 13 1.0 mA
 q371 13 343 350 qp

q381 15 343 351 qn
q391 15 350 352 qn
q301 13 351 353 qp
ros13 352 9 2
ros23 353 9 2
*

* Power Supply Current
*

ips 15 13 22 mA
*

*Models
*

.model qp pnp(is=1.5e-16 bf=300 tf=0.01 ns)
.model qn npn(is=0.8e-18 bf=300 tf=0.01 ns)
.ends

**© Copyright Intersil Americas LLC 2002-2004. All Rights Reserved.
All trademarks and registered trademarks are the property of their respective owners.**

For additional products, see www.intersil.com/en/products.html

Intersil products are manufactured, assembled and tested utilizing ISO9001 quality systems as noted
in the quality certifications found at www.intersil.com/en/support/qualandreliability.html

Intersil products are sold by description only. Intersil may modify the circuit design and/or specifications of products at any time without notice, provided that such modification does not, in Intersil's sole judgment, affect the form, fit or function of the product. Accordingly, the reader is cautioned to verify that datasheets are current before placing orders. Information furnished by Intersil is believed to be accurate and reliable. However, no responsibility is assumed by Intersil or its subsidiaries for its use; nor for any infringements of patents or other rights of third parties which may result from its use. No license is granted by implication or otherwise under any patent or patent rights of Intersil or its subsidiaries.

For information regarding Intersil Corporation and its products, see www.intersil.com