

# EL5177

550MHz Differential Twisted-Pair Driver

FN7344  
Rev 6.00  
August 28, 2012

The EL5177 is a high bandwidth amplifier with an output in differential form. It is primarily targeted for applications such as driving twisted-pair lines or any application where common mode injection is likely to occur. The input signal can be in either single-ended or differential form but the output is always in differential form.

On the EL5177, two feedback inputs provide the user with the ability to set the device gain (stable at a minimum gain of 1).

The output common mode level is set by the reference pin (REF), which has a -3dB bandwidth of 110MHz. Generally, this pin is grounded but it can be tied to any voltage reference.

Both outputs (OUT+, OUT-) are short circuit protected to withstand temporary overload condition.

The EL5177 is available in the 10 Ld MSOP package and is specified for operation over the full -40°C to +85°C temperature range.

See also EL5174 (EL5177 in 8 Ld MSOP).

## Features

- Fully differential inputs, outputs, and feedback
- Differential input range  $\pm 2.3V$
- 550MHz 3dB bandwidth
- 1100V/ $\mu s$  slew rate
- Low distortion at 20MHz
- Single 5V or dual  $\pm 5V$  supplies
- 40mA maximum output current
- Low power, 12.5mA typical supply current
- Pb-free (RoHS compliant)

## Applications

- Twisted-pair drivers
- Differential line drivers
- VGA over twisted-pair
- ADSL/HDSL drivers
- Single-ended to differential amplification
- Transmission of analog signals in a noisy environment

## Pinout

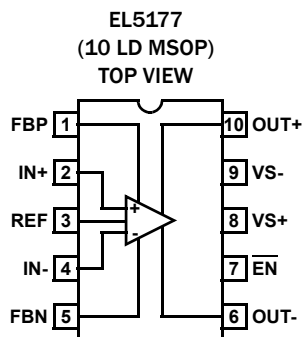

## Pin Descriptions

PIN NUMBER	PIN NAME	PIN DESCRIPTION
1	FBP	Non-inverting feedback input; resistor $R_{F1}$ must be connected from this pin to $V_{OUT}$
2	IN+	Non-inverting input
3	REF	Output common-mode control; the common-mode voltage of $V_{OUT}$ will follow the voltage on this pin
4	IN-	Inverting input
5	FBN	Inverting feedback input; resistor $R_{F2}$ must be connected from this pin to $V_{OUT}$
6	OUT-	Inverting output
7	$\overline{EN}$	Enabled when this pin is floating or the applied voltage $\leq V_{S+} - 1.5$
8	VS+	Positive supply
9	VS-	Negative supply
10	OUT+	Non-inverting output

## Ordering Information

PART NUMBER (Notes 1, 2, 3)	PART MARKING	PACKAGE (Pb-free)	PKG. DWG. #
EL5177IYZ	BAAKA	10 Ld MSOP (3.0mm)	M10.118A

### NOTES:

1. Add "-T\*" suffix for tape and reel. Please refer to [TB347](#) for details on reel specifications.
2. These Intersil Pb-free plastic packaged products employ special Pb-free material sets, molding compounds/die attach materials, and 100% matte tin plate plus anneal (e3 termination finish, which is RoHS compliant and compatible with both SnPb and Pb-free soldering operations). Intersil Pb-free products are MSL classified at Pb-free peak reflow temperatures that meet or exceed the Pb-free requirements of IPC/JEDEC J STD-020.
3. For Moisture Sensitivity Level (MSL), please see device information page for [EL5177](#). For more information on MSL please see tech brief [TB363](#).

**Absolute Maximum Ratings** (T<sub>A</sub> = +25°C)

Supply Voltage (V<sub>S+</sub> to V<sub>S-</sub>) ..... 12V  
 V<sub>IN</sub>, V<sub>INB</sub>, V<sub>REF</sub> ..... V<sub>S-</sub> + 0.8V (min) to V<sub>S+</sub> - 0.8V (max)  
 V<sub>IN</sub> - V<sub>INB</sub> ..... ±5  
 Supply Voltage Rate-of-rise (dV/dT) ..... 1V/μs  
 Input Voltage (IN+, IN- to V<sub>S+</sub>, V<sub>S-</sub>) ..... V<sub>S-</sub> - 0.3V to V<sub>S+</sub> + 0.3V  
 Differential Input Voltage (IN+ to IN-) ..... ±4.8V  
 Maximum Output Current ..... ±60mA

**Thermal Information**

Recommended Operating Temperature ..... -40°C to +85°C  
 Operating Junction Temperature ..... +135°C  
 Storage Temperature Range ..... -65°C to +150°C  
 Power Dissipation ..... See Curves  
 Pb-Free Reflow Profile ..... see link below  
<http://www.intersil.com/pbfree/Pb-FreeReflow.asp>

CAUTION: Do not operate at or near the maximum ratings listed for extended periods of time. Exposure to such conditions may adversely impact product reliability and result in failures not covered by warranty.

IMPORTANT NOTE: All parameters having Min/Max specifications are guaranteed. Typ values are for information purposes only. Unless otherwise noted, all tests are at the specified temperature and are pulsed tests, therefore: T<sub>J</sub> = T<sub>C</sub> = T<sub>A</sub>

**Electrical Specifications** V<sub>S+</sub> = +5V, V<sub>S-</sub> = -5V, T<sub>A</sub> = +25°C, V<sub>IN</sub> = 0V, R<sub>LD</sub> = 1kΩ, R<sub>F</sub> = 0, R<sub>G</sub> = OPEN, C<sub>LD</sub> = 2.7pF, Unless Otherwise Specified.

PARAMETER	DESCRIPTION	CONDITIONS	MIN (Note 4)	TYP	MAX (Note 4)	UNIT
<b>AC PERFORMANCE</b>						
BW	-3dB Bandwidth	A <sub>V</sub> = 1, C <sub>LD</sub> = 2.7pF		550		MHz
		A <sub>V</sub> = 2, R <sub>F</sub> = 500, C <sub>LD</sub> = 2.7pF		130		MHz
		A <sub>V</sub> = 10, R <sub>F</sub> = 500, C <sub>LD</sub> = 2.7pF		20		MHz
BW	±0.1dB Bandwidth	A <sub>V</sub> = 1, C <sub>LD</sub> = 2.7pF		120		MHz
SR	Slew Rate	V <sub>OUT</sub> = 3V <sub>P-P</sub> , 20% to 80%	800	1100		V/μs
t <sub>STL</sub>	Settling Time to 0.1%	V <sub>OUT</sub> = 2V <sub>P-P</sub>		10		ns
t <sub>OVR</sub>	Output Overdrive Recovery Time			20		ns
GBWP	Gain Bandwidth Product			200		MHz
V <sub>REF</sub> BW (-3dB)	V <sub>REF</sub> -3dB Bandwidth	A <sub>V</sub> = 1, C <sub>LD</sub> = 2.7pF		110		MHz
V <sub>REF</sub> SR+	V <sub>REF</sub> Slew Rate - Rise	V <sub>OUT</sub> = 2V <sub>P-P</sub> , 20% to 80%		134		V/μs
V <sub>REF</sub> SR-	V <sub>REF</sub> Slew Rate - Fall	V <sub>OUT</sub> = 2V <sub>P-P</sub> , 20% to 80%		70		V/μs
V <sub>N</sub>	Input Voltage Noise	at 10kHz		21		nV/√Hz
I <sub>N</sub>	Input Current Noise	at 10kHz		2.7		pA/√Hz
HD2	Second Harmonic Distortion	V <sub>OUT</sub> = 2V <sub>P-P</sub> , 5MHz		-95		dBc
		V <sub>OUT</sub> = 2V <sub>P-P</sub> , 20MHz		-94		dBc
HD3	Third Harmonic Distortion	V <sub>OUT</sub> = 2V <sub>P-P</sub> , 5MHz		-88		dBc
		V <sub>OUT</sub> = 2V <sub>P-P</sub> , 20MHz		-87		dBc
dG	Differential Gain at 3.58MHz	R <sub>LD</sub> = 300Ω, A <sub>V</sub> = 2		0.06		%
dθ	Differential Phase at 3.58MHz	R <sub>LD</sub> = 300Ω, A <sub>V</sub> = 2		0.13		°
<b>INPUT CHARACTERISTICS</b>						
V <sub>OS</sub>	Input Referred Offset Voltage			±1.4	±25	mV
I <sub>IN</sub>	Input Bias Current (V <sub>IN+</sub> , V <sub>IN-</sub> )		-30	-14	-7	μA
I <sub>REF</sub>	Input Bias Current (V <sub>REF</sub> )		0.5	2.3	4	μA
R <sub>IN</sub>	Differential Input Resistance			150		kΩ
C <sub>IN</sub>	Differential Input Capacitance			1		pF
DMIR	Differential Mode Input Range		±2.1	±2.3	±2.5	V
CMIR+	Common Mode Positive Input Range at V <sub>IN+</sub> , V <sub>IN-</sub>			3.4		V

**Electrical Specifications**  $V_{S+} = +5V$ ,  $V_{S-} = -5V$ ,  $T_A = +25^\circ C$ ,  $V_{IN} = 0V$ ,  $R_{LD} = 1k\Omega$ ,  $R_F = 0$ ,  $R_G = OPEN$ ,  $C_{LD} = 2.7pF$ , Unless Otherwise Specified. (Continued)

PARAMETER	DESCRIPTION	CONDITIONS	MIN (Note 4)	TYP	MAX (Note 4)	UNIT
CMIR-	Common Mode Negative Input Range at $V_{IN+}$ , $V_{IN-}$			-4.3		V
$V_{REFIN+}$	Positive Reference Input Voltage Range	$V_{IN+} = V_{IN-} = 0V$	3.4	3.7		V
$V_{REFIN-}$	Negative Reference Input Voltage Range	$V_{IN+} = V_{IN-} = 0V$		-3.3	-3	V
$V_{REFOS}$	Output Offset Relative to $V_{REF}$			$\pm 50$	$\pm 100$	mV
CMRR	Input Common Mode Rejection Ratio	$V_{IN} = \pm 2.5V$	65	78		dB
Gain	Gain Accuracy	$V_{IN} = 1V$	0.980	0.995	1.010	V
<b>OUTPUT CHARACTERISTICS</b>						
$V_{OUT}$	Output Voltage Swing	$R_L = 500\Omega$ to GND	$\pm 3.6$	$\pm 3.8$		V
$I_{OUT+}(Max)$	Maximum Source Output Current	$R_L = 10\Omega$ , $V_{IN+} = 1.1V$ , $V_{IN-} = -1.1V$ , $V_{REF} = 0$	35	50		mA
$I_{OUT-}(Max)$	Maximum Sink Output Current			-40	-30	mA
$R_{OUT}$	Output Impedance			130		$m\Omega$
<b>SUPPLY</b>						
$V_{SUPPLY}$	Supply Operating Range	$V_{S+}$ to $V_{S-}$	4.75		11	V
$I_{S(ON)}$	Power Supply Current - Per Channel		10	12.5	14	mA
$I_{S(OFF)+}$	Positive Power Supply Current - Disabled	$\overline{EN}$ pin tied to 4.8V		76	120	$\mu A$
$I_{S(OFF)-}$	Negative Power Supply Current - Disabled			-200	-120	$\mu A$
PSRR	Power Supply Rejection Ratio	$V_S$ from $\pm 4.5V$ to $\pm 5.5V$	60	75		dB
<b>ENABLE</b>						
$t_{EN}$	Enable Time			130		ns
$t_{DS}$	Disable Time			1.2		$\mu s$
$V_{IH}$	$\overline{EN}$ Pin Voltage for Power-Up				$V_{S+} - 1.5$	V
$V_{IL}$	$\overline{EN}$ Pin Voltage for Shutdown		$V_{S+} - 0.5$			V
$I_{IH-EN}$	$\overline{EN}$ Pin Input Current High	At $V_{EN} = 5V$		40	50	$\mu A$
$I_{IL-EN}$	$\overline{EN}$ Pin Input Current Low	At $V_{EN} = 0V$	-6	-2.5		$\mu A$

## NOTE:

4. Parameters with MIN and/or MAX limits are 100% tested at  $+25^\circ C$ , unless otherwise specified. Temperature limits established by characterization and are not production tested.

# Connection Diagram

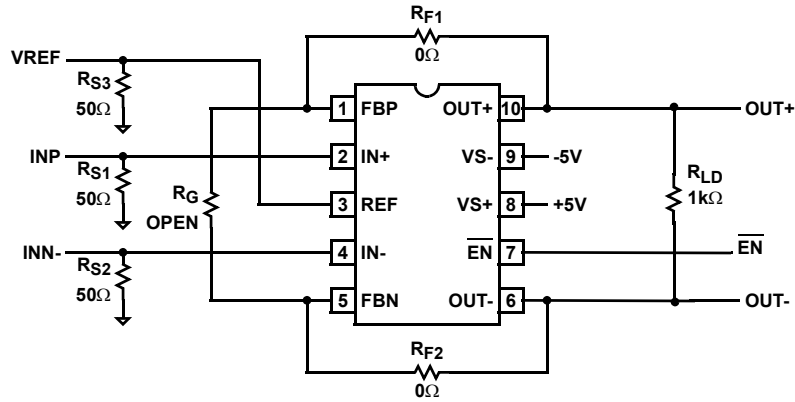

# Typical Performance Curves

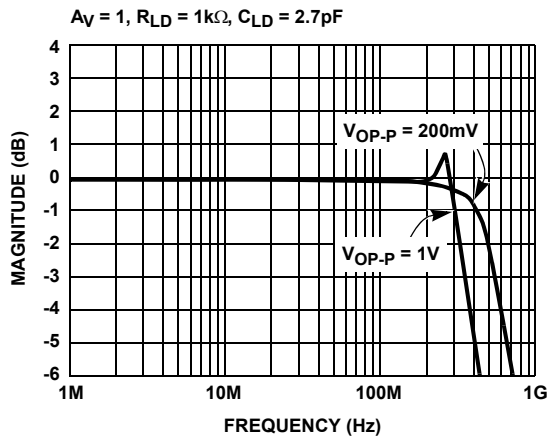

FIGURE 1. FREQUENCY RESPONSE

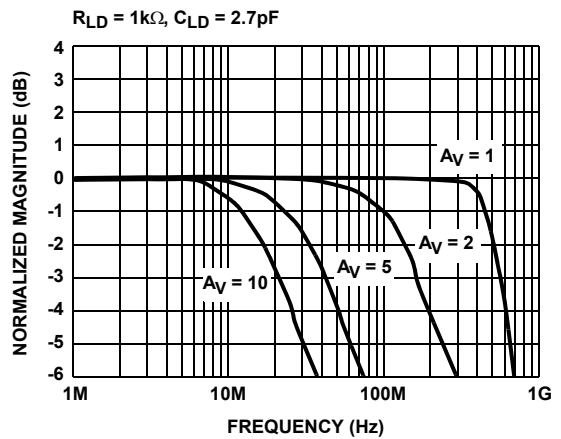

FIGURE 2. FREQUENCY RESPONSE FOR VARIOUS GAIN

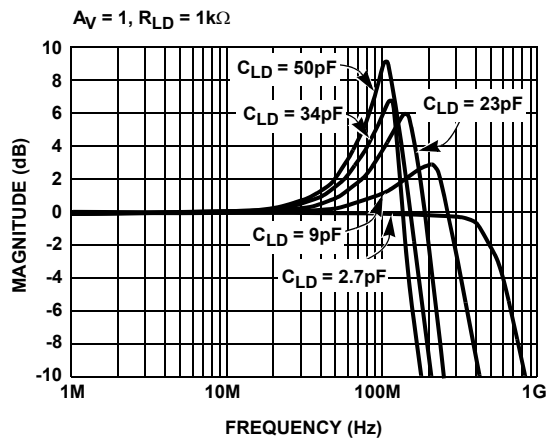

FIGURE 3. FREQUENCY RESPONSE vs CLD

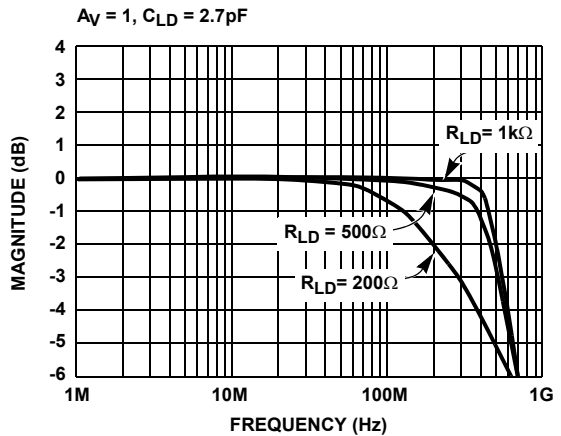

FIGURE 4. FREQUENCY RESPONSE vs RLD

# Typical Performance Curves (Continued)

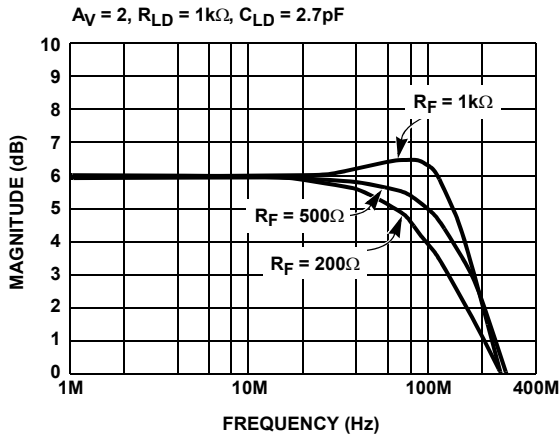

FIGURE 5. FREQUENCY RESPONSE

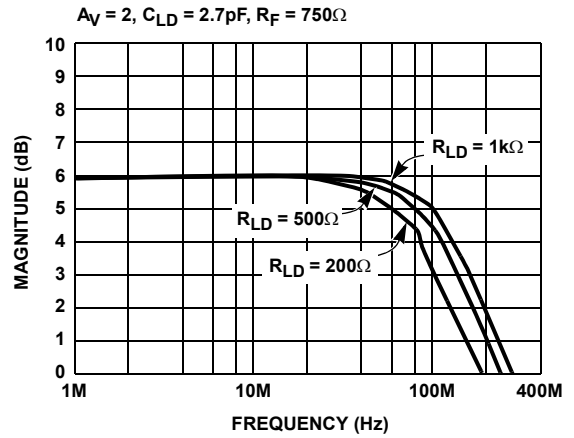

FIGURE 6. FREQUENCY RESPONSE vs  $R_{LD}$

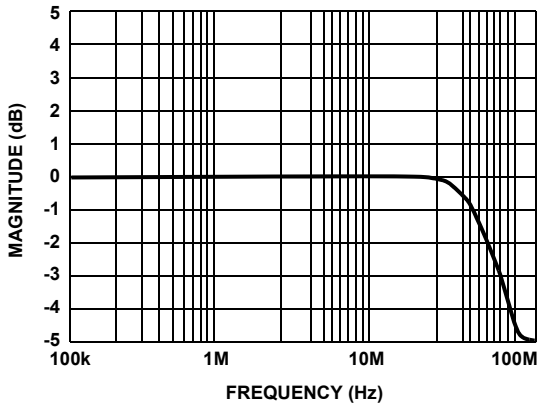

FIGURE 7. FREQUENCY RESPONSE -  $V_{REF}$

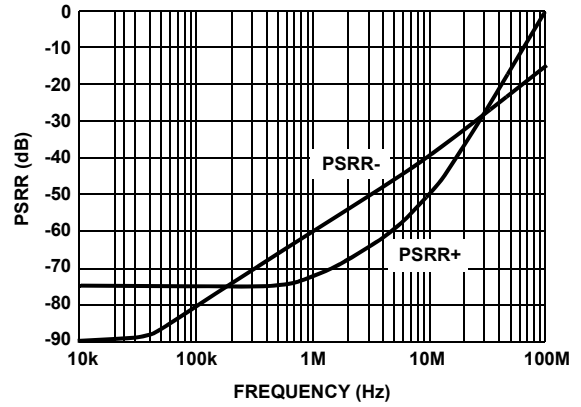

FIGURE 8. PSRR vs FREQUENCY

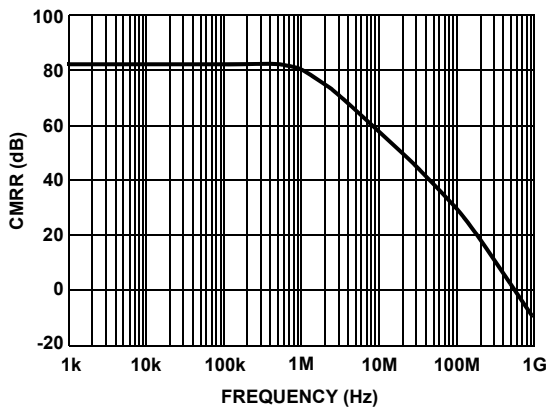

FIGURE 9. CMRR vs FREQUENCY

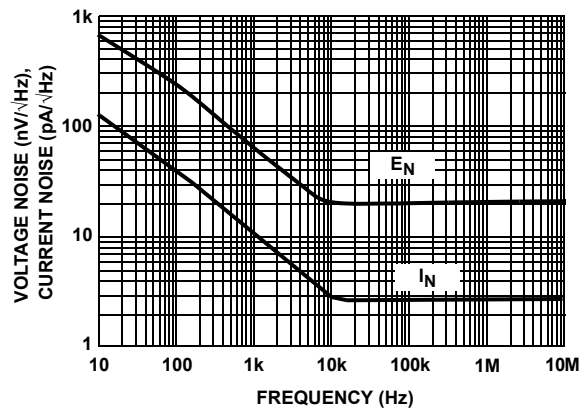

FIGURE 10. VOLTAGE AND CURRENT NOISE vs FREQUENCY

# Typical Performance Curves (Continued)

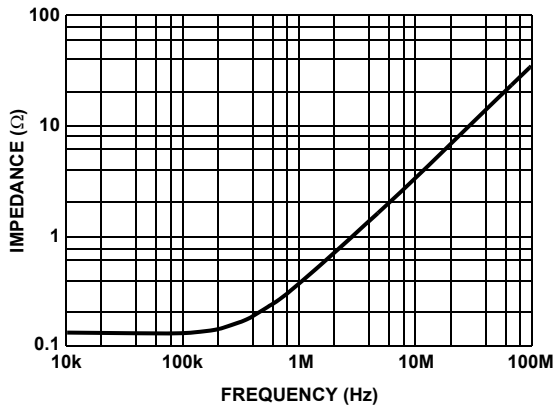

FIGURE 11. OUTPUT IMPEDANCE vs FREQUENCY

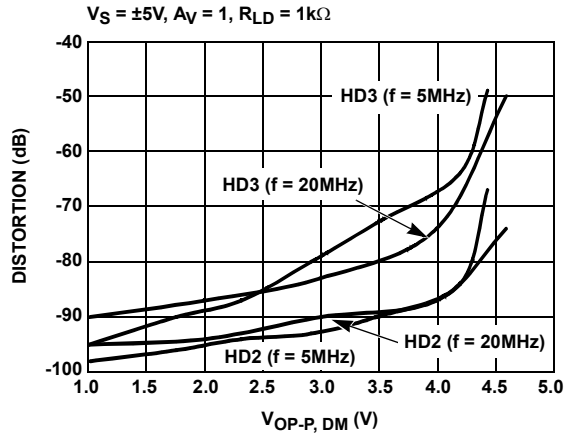

FIGURE 12. HARMONIC DISTORTION vs DIFFERENTIAL OUTPUT VOLTAGE

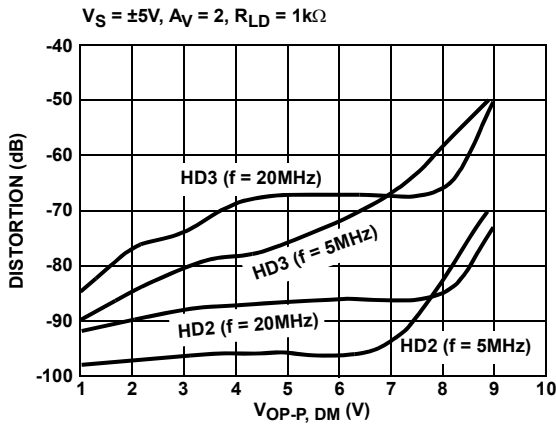

FIGURE 13. HARMONIC DISTORTION vs DIFFERENTIAL OUTPUT VOLTAGE

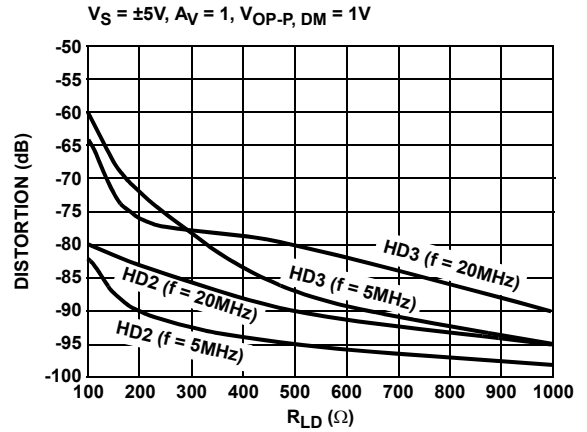

FIGURE 14. HARMONIC DISTORTION vs R<sub>LD</sub>

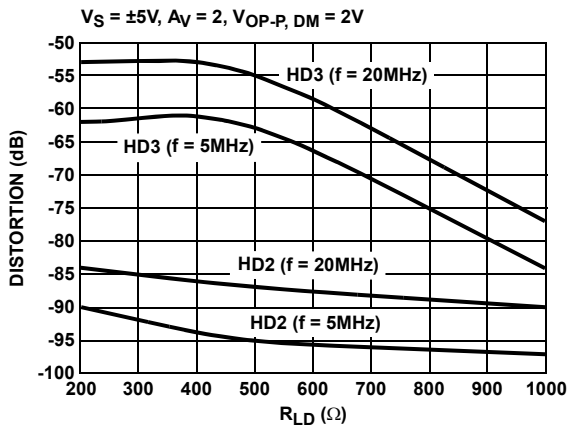

FIGURE 15. HARMONIC DISTORTION vs R<sub>LD</sub>

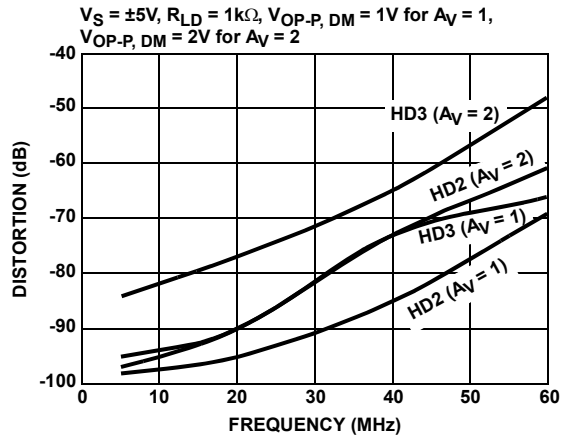

FIGURE 16. HARMONIC DISTORTION vs FREQUENCY

# Typical Performance Curves (Continued)

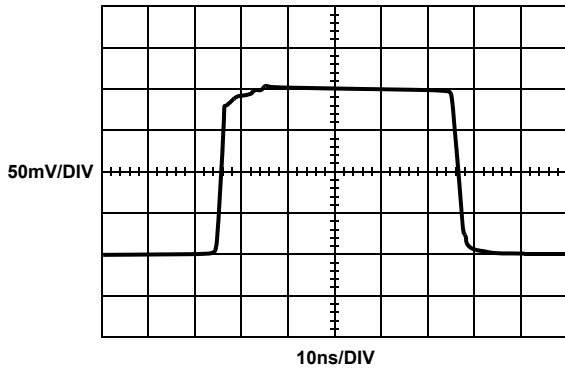

FIGURE 17. SMALL SIGNAL TRANSIENT RESPONSE

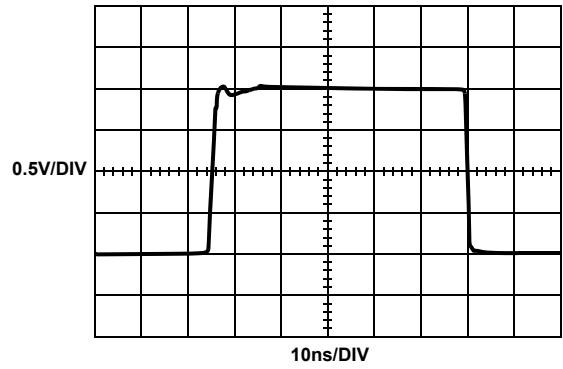

FIGURE 18. LARGE SIGNAL TRANSIENT RESPONSE

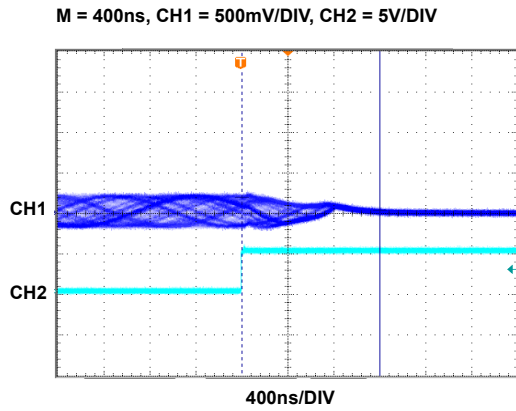

FIGURE 19. ENABLED RESPONSE

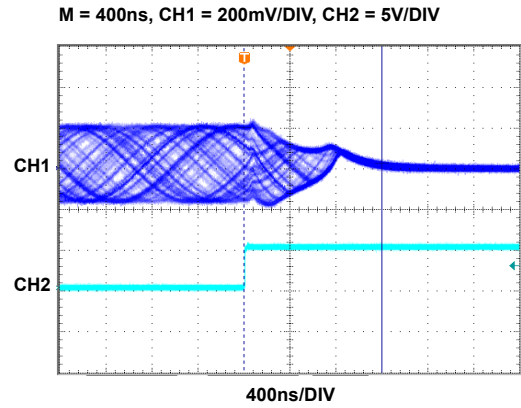

FIGURE 20. DISABLED RESPONSE

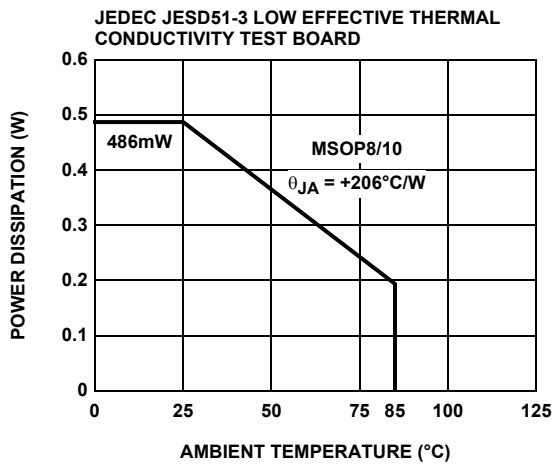

FIGURE 21. PACKAGE POWER DISSIPATION vs AMBIENT TEMPERATURE

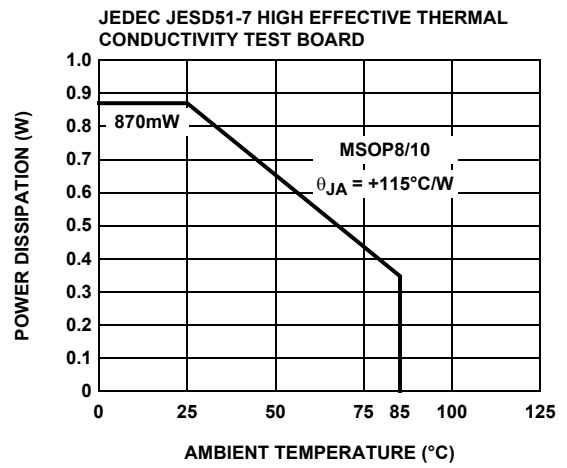
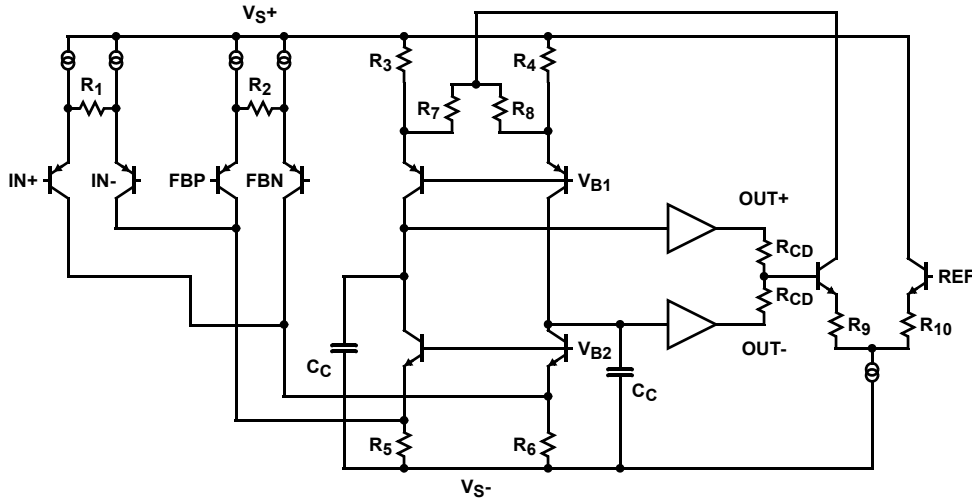

FIGURE 22. PACKAGE POWER DISSIPATION vs AMBIENT TEMPERATURE



## Simplified Schematic



## Description of Operation and Application Information

### Product Description

The EL5177 is a wide bandwidth, low power and single/differential ended to differential output amplifier. It can be used as single/differential ended to differential converter. The EL5177 is internally compensated for closed loop gain of +1 or greater. Connected in gain of 1 and driving a 1kΩ differential load, the EL5177 has a -3dB bandwidth of 550MHz. Driving a 200Ω differential load at gain of 2, the bandwidth is about 130MHz. The EL5177 is available with a power-down feature to reduce the power while the amplifier is disabled.

### Input, Output, and Supply Voltage Range

The EL5177 has been designed to operate with a single supply voltage of 5V to 10V or a split supplies with its total voltage from 5V to 10V. The amplifiers have an input common mode voltage range from -4.3V to 3.4V for ±5V supply. The differential mode input range (DMIR) between the two inputs is from -2.3V to +2.3V. The input voltage range at the REF pin is from -3.3V to 3.7V. If the input common mode or differential mode signal is outside the above-specified ranges, it will cause the output signal to become distorted.

The output of the EL5177 can swing from -3.8V to +3.8V at a 1kΩ differential load at ±5V supply. As the load resistance becomes lower, the output swing is reduced.

### Differential and Common Mode Gain Settings

The voltage applied at REF pin can set the output common mode voltage and the gain is one. The differential gain is set by the  $R_F$  and  $R_G$  network.

The gain setting for EL5177 is expressed in Equation 1:

$$V_{ODM} = (V_{IN+} - V_{IN-}) \times \left( 1 + \frac{R_{F1} + R_{F2}}{R_G} \right)$$

$$V_{ODM} = (V_{IN+} - V_{IN-}) \times \left( 1 + \frac{2R_F}{R_G} \right) \tag{EQ. 1}$$

$$V_{OCM} = V_{REF}$$

Where:

$$R_{F1} = R_{F2} = R_F$$

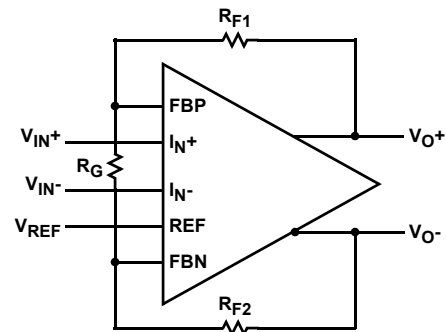

FIGURE 23.

### Choice of Feedback Resistor and Gain Bandwidth Product

For applications that require a gain of +1, no feedback resistor is required. Just short the OUT+ pin to FBP pin and OUT- pin to FBN pin. For gains greater than +1, the feedback resistor forms a pole with the parasitic capacitance at the inverting input. As this pole becomes smaller, the amplifier's phase margin is reduced. This causes ringing in the time domain and peaking in the frequency domain. Therefore,  $R_F$  has some maximum value that should not be exceeded for optimum performance. If a large value of  $R_F$  must be used, a small capacitor in the few Pico farad range in parallel with  $R_F$  can help to reduce the ringing and peaking at the expense of reducing the bandwidth.

The bandwidth of the EL5177 depends on the load and the feedback network.  $R_F$  and  $R_G$  appear in parallel with the load for gains other than +1. As this combination gets smaller, the bandwidth falls off. Consequently,  $R_F$  also has a minimum value that should not be exceeded for optimum bandwidth performance. For gain of +1,  $R_F = 0$  is optimum. For the gains other than +1, optimum response is obtained with  $R_F$  between  $500\Omega$  to  $1k\Omega$ .

The EL5177 has a gain bandwidth product of 200MHz for  $R_{LD} = 1k\Omega$ . For gains  $\geq 5$ , its bandwidth can be predicted by Equation 2:

$$\text{Gain} \times \text{BW} = 200\text{MHz} \quad (\text{EQ. 2})$$

## Driving Capacitive Loads and Cables

The EL5177 can drive a 23pF differential capacitor in parallel with a  $1k\Omega$  differential load with less than 5dB of peaking at gain of +1. If less peaking is desired in applications, a small series resistor (usually between  $5\Omega$  to  $50\Omega$ ) can be placed in series with each output to eliminate most peaking. However, this will reduce the gain slightly. If the gain setting is greater than 1, the gain resistor  $R_G$  can then be chosen to make up for any gain loss which may be created by the additional series resistor at the output.

When used as a cable driver, double termination is always recommended for reflection-free performance. For those applications, a back-termination series resistor at the amplifier's output will isolate the amplifier from the cable and allow extensive capacitive drive. However, other applications may have high capacitive loads without a back-termination resistor. Again, a small series resistor at the output can help to reduce peaking.

## Disable/Power-Down

The EL5177 can be disabled and its outputs placed in a high impedance state. The turn-off time is about  $1.2\mu\text{s}$  and the turn-on time is about 130ns. When disabled, the amplifier's supply current is reduced to  $1.7\mu\text{A}$  for  $I_{S+}$  and  $120\mu\text{A}$  for  $I_{S-}$  typically, thereby effectively eliminating the power consumption. The amplifier's power-down can be controlled by standard CMOS signal levels at the EN pin. The applied logic signal is relative to  $V_{S+}$  pin. Letting the  $\overline{\text{EN}}$  pin float or applying a signal that is less than 1.5V below  $V_{S+}$  will enable the amplifier. The amplifier will be disabled when the signal at the  $\overline{\text{EN}}$  pin is above  $V_{S+} - 0.5\text{V}$ .

## Output Drive Capability

The EL5177 has internal short circuit protection. Its typical short circuit current is  $\pm 40\text{mA}$ . If the output is shorted indefinitely, the power dissipation could easily increase such that the part will be destroyed. Maximum reliability is maintained if the output current never exceeds  $\pm 40\text{mA}$ . This limit is set by the design of the internal metal interconnect.

## Power Dissipation

With the high output drive capability of the EL5177, it is possible to exceed the  $+135^\circ\text{C}$  absolute maximum junction temperature under certain load current conditions. Therefore, it is important to calculate the maximum junction temperature for the application to determine if the load conditions or package types

need to be modified for the amplifier to remain in the safe operating area.

The maximum power dissipation allowed in a package is determined according to Equation 3:

$$P_{D_{MAX}} = \frac{T_{J_{MAX}} - T_{A_{MAX}}}{\theta_{JA}} \quad (\text{EQ. 3})$$

Where:

$T_{J_{MAX}}$  = Maximum junction temperature

$T_{A_{MAX}}$  = Maximum ambient temperature

$\theta_{JA}$  = Thermal resistance of the package

The maximum power dissipation actually produced by an IC is the total quiescent supply current times the total power supply voltage, plus the power in the IC due to the load, or:

$$PD = i \times \left( V_{STOT} \times I_{S_{MAX}} + (V_{STOT} - \Delta V_O) \times \frac{\Delta V_O}{R_{LD}} \right) \quad (\text{EQ. 4})$$

Where:

$V_{STOT}$  = Total supply voltage =  $V_{S+} - V_{S-}$

$I_{S_{MAX}}$  = Maximum quiescent supply current per channel

$\Delta V_O$  = Maximum differential output voltage of the application

$R_{LD}$  = Differential load resistance

$I_{LOAD}$  = Load current

$i$  = Number of channels

By setting the two  $P_{D_{MAX}}$  equations equal to each other, we can solve the output current and  $R_{LD}$  to avoid the device overheat.

## Power Supply Bypassing and Printed Circuit Board Layout

As with any high frequency device, a good printed circuit board layout is necessary for optimum performance. Lead lengths should be as short as possible. The power supply pin must be well bypassed to reduce the risk of oscillation. For normal single supply operation, where the  $V_{S-}$  pin is connected to the ground plane, a single  $4.7\mu\text{F}$  tantalum capacitor in parallel with a  $0.1\mu\text{F}$  ceramic capacitor from  $V_{S+}$  to GND will suffice. This same capacitor combination should be placed at each supply pin to ground if split supplies are to be used. In this case, the  $V_{S-}$  pin becomes the negative supply rail.

For good AC performance, parasitic capacitance should be kept to a minimum. Use of wire-wound resistors should be avoided because of their additional series inductance. Use of sockets should also be avoided if possible. Sockets add parasitic inductance and capacitance that can result in compromised performance. Minimizing parasitic capacitance at the amplifier's inverting input pin is very important. The feedback resistor should be placed very close to the inverting input pin. Strip line design techniques are recommended for the signal traces.

As the signal is transmitted through a cable, the high frequency signal will be attenuated. One way to compensate this loss is to boost the high frequency gain at the receiver side.

# Typical Applications

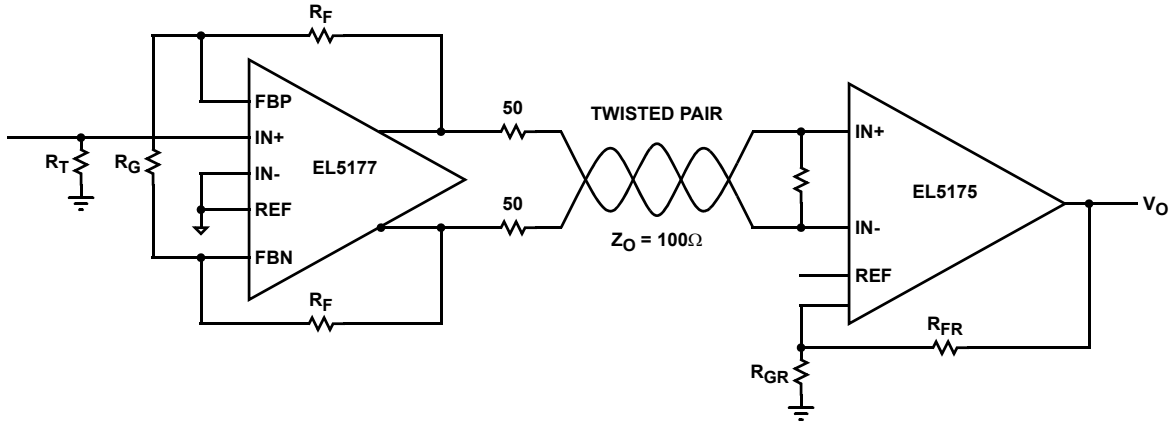
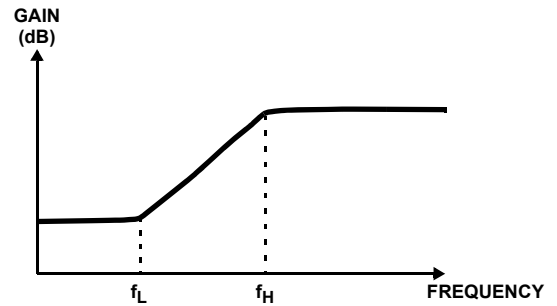
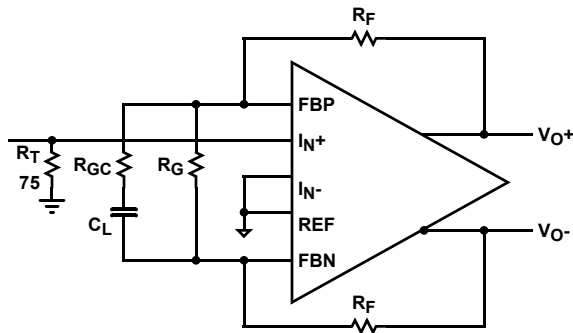

FIGURE 24. TWISTED PAIR CABLE RECEIVER



$$\text{DC Gain} = 1 + \frac{2R_F}{R_G}$$

$$\text{(HF)Gain} = 1 + \frac{2R_F}{R_G \parallel R_{GC}}$$

$$f_L \cong \frac{1}{2\pi R_G C_C}$$

$$f_H \cong \frac{1}{2\pi R_{GC} C_C}$$

FIGURE 25. TRANSMIT EQUALIZER

© Copyright Intersil Americas LLC 2003-2012 All Rights Reserved.  
 All trademarks and registered trademarks are the property of their respective owners.

For additional products, see [www.intersil.com/en/products.html](http://www.intersil.com/en/products.html)

Intersil products are manufactured, assembled and tested utilizing ISO9001 quality systems as noted in the quality certifications found at [www.intersil.com/en/support/qualandreliability.html](http://www.intersil.com/en/support/qualandreliability.html)

*Intersil products are sold by description only. Intersil may modify the circuit design and/or specifications of products at any time without notice, provided that such modification does not, in Intersil's sole judgment, affect the form, fit or function of the product. Accordingly, the reader is cautioned to verify that datasheets are current before placing orders. Information furnished by Intersil is believed to be accurate and reliable. However, no responsibility is assumed by Intersil or its subsidiaries for its use; nor for any infringements of patents or other rights of third parties which may result from its use. No license is granted by implication or otherwise under any patent or patent rights of Intersil or its subsidiaries.*

For information regarding Intersil Corporation and its products, see [www.intersil.com](http://www.intersil.com)

# Package Outline Drawing

## M10.118A (JEDEC MO-187-BA)

10 LEAD MINI SMALL OUTLINE PLASTIC PACKAGE (MSOP)

Rev 0, 9/09

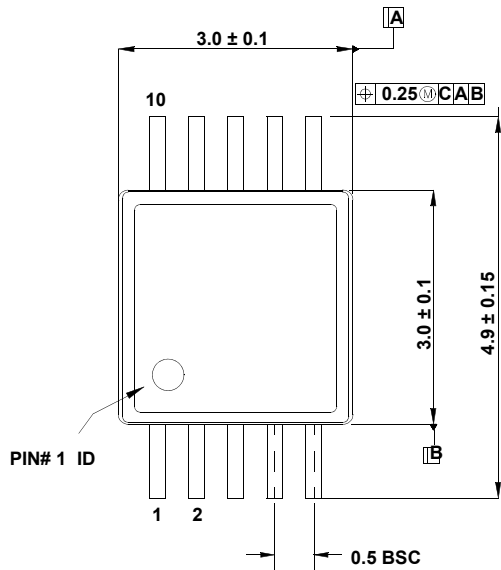

TOP VIEW

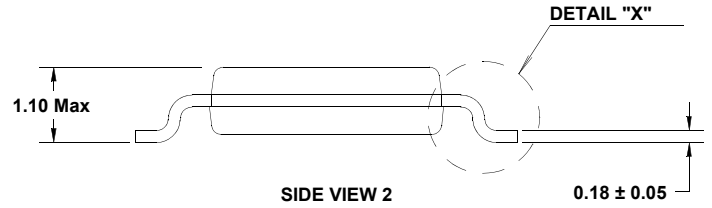

SIDE VIEW 2

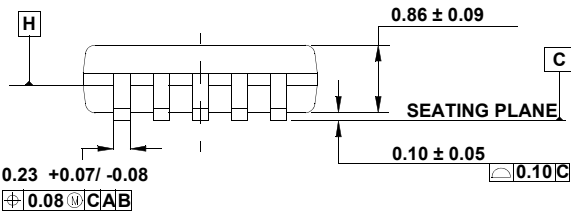

SIDE VIEW 1

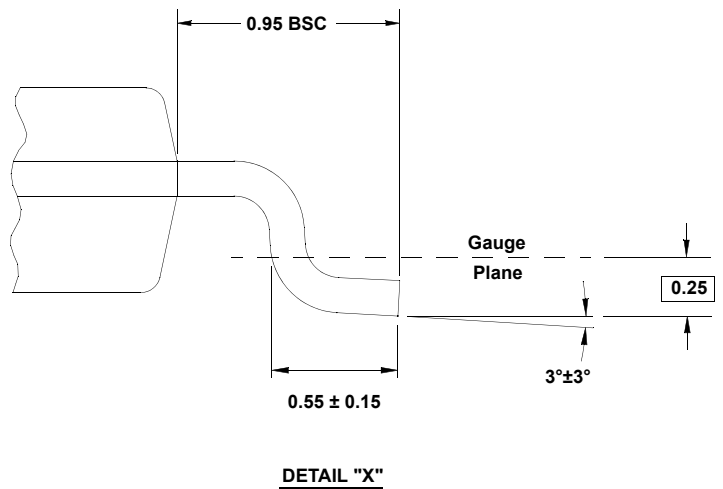

DETAIL "X"

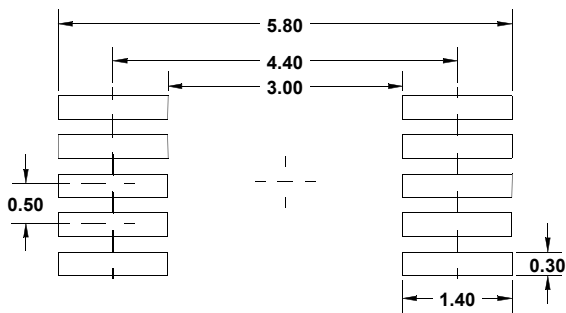

TYPICAL RECOMMENDED LAND PATTERN

NOTES:

1. Dimensions are in millimeters.
2. Dimensioning and tolerancing conform to AMSE Y14.5m-1994.
3. Plastic or metal protrusions of 0.15mm max per side are not included.
4. Plastic interlead protrusions of 0.25mm max per side are not included.
5. Dimensions "D" and "E1" are measured at Datum Plane "H".
6. This replaces existing drawing # MDP0043 MSOP10L.