

FS1027-DL

Liquid Flow Sensor Module

The FS1027-DL liquid flow sensor module measures the flow rate using the thermo-transfer (calorimetric) principle.

The FS1027-DL offers key advantages over resistor-based flow solutions. The sensor utilizes thermopile sensing, which provides an excellent signal-to-noise ratio. The sensor comprises a “solid” thermal isolation technology with protective coating.

The non-linear flow output curve allows for sensitivity from low to full-scale flow rates. The FS1027-DL provides digital I²C and analog output.

FS1027-DL Module Picture



Features

- Liquid flow: 0 to 10 liters/min (in water)
- Robust “solid” isolation technology
- Resistant to vibration and pressure shock
- Minimal flow resistance
- Digital I²C output
- Analog voltage output
- Supply voltage: 5V

Applications

- Water dispensers
- Liquid metering or switch
- Process controls and monitoring



COMPONENT

Contents

1. Pin Information	3
1.1 Pin Assignments	3
1.2 Pin Descriptions.....	3
2. Specifications	4
2.1 Absolute Maximum Ratings	4
2.2 Recommended Operating Conditions.....	4
2.3 Electrical Characteristics	4
3. Typical Flow Graphs.....	5
4. I2C Sensor Interface.....	7
4.1 Sensor Slave Address	7
4.2 I2C Communication	7
4.3 Digital Output Measurements	8
4.4 Calculating Checksum.....	8
4.5 Electrical Connector.....	9
4.6 Module Material	9
4.7 Tubing Guidance	9
5. Package Outline Drawings.....	10
6. Ordering Information.....	10
7. Revision History	10

1. Pin Information

1.1 Pin Assignments

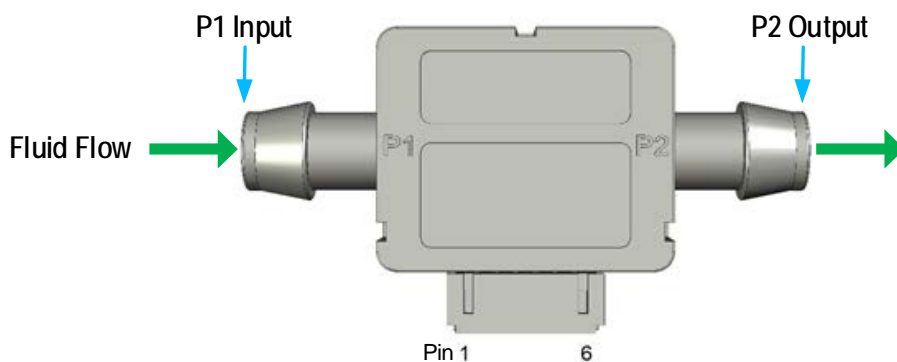

Top View

1.2 Pin Descriptions

Pin Number	Pad Name	Type	Description
1	VDD	Input	Supply voltage.
2	GND	Input	Ground.
3	OUTPUT	Output	Flow analog output.
4	SDA	In/Out	Serial data.
5	SCL	Input	Serial clock.
6	NC	-	Do not connect. ^[1]

1. "NC" stands for not connected / no connection required / not bonded.

2. Specifications

2.1 Absolute Maximum Ratings

CAUTION: Do not operate at or near the maximum ratings listed for extended periods of time. Exposure to such conditions can adversely impact product reliability and result in failures not covered by warranty.

Symbol	Parameter	Conditions	Minimum	Maximum	Unit
V_{IN}	Supply Voltage	-	2.7	5.5	V
T_{STOR}	Storage Temperature	-	0	85	°C

2.2 Recommended Operating Conditions

Symbol	Parameter	Minimum	Typical	Maximum	Unit
V_{IN}	Supply Voltage	4.7	5	5.5	V
T_{AMB}	Ambient Operating Temperature (in air)	0	-	70	°C
P_{STAT}	Static Pressure	-	-	30	PSI

2.3 Electrical Characteristics

Symbol	Parameter	Conditions	Minimum	Typical	Maximum	Unit
I_{VIN}	Current Consumption	-	-	20	25	mA
F_{LQ}	Liquid Flow Range	Tested with water, room temperature	0	-	10	Liter/min
V_{AOUT}	Analog Voltage Output	At 0 liters/min	-	0.5	-	V
		At 10 liters/min	-	4.5	-	
V_{DOUT}	Digital Output	At 0 liters/min	-	409	-	Counts
		At 10 liters/min	-	3686	-	
τ_H	Flow Response Time ^[1]	-	-	5	-	msec

- The flow response time includes a 10% to 90% rise time for the flow sensor to electrically respond to any flow change. Measurements may be affected by the pneumatic interface.

3. Typical Flow Graphs

Figure 1 and Figure 2 show the typical digital and analog output versus flow, with water, room temperature.

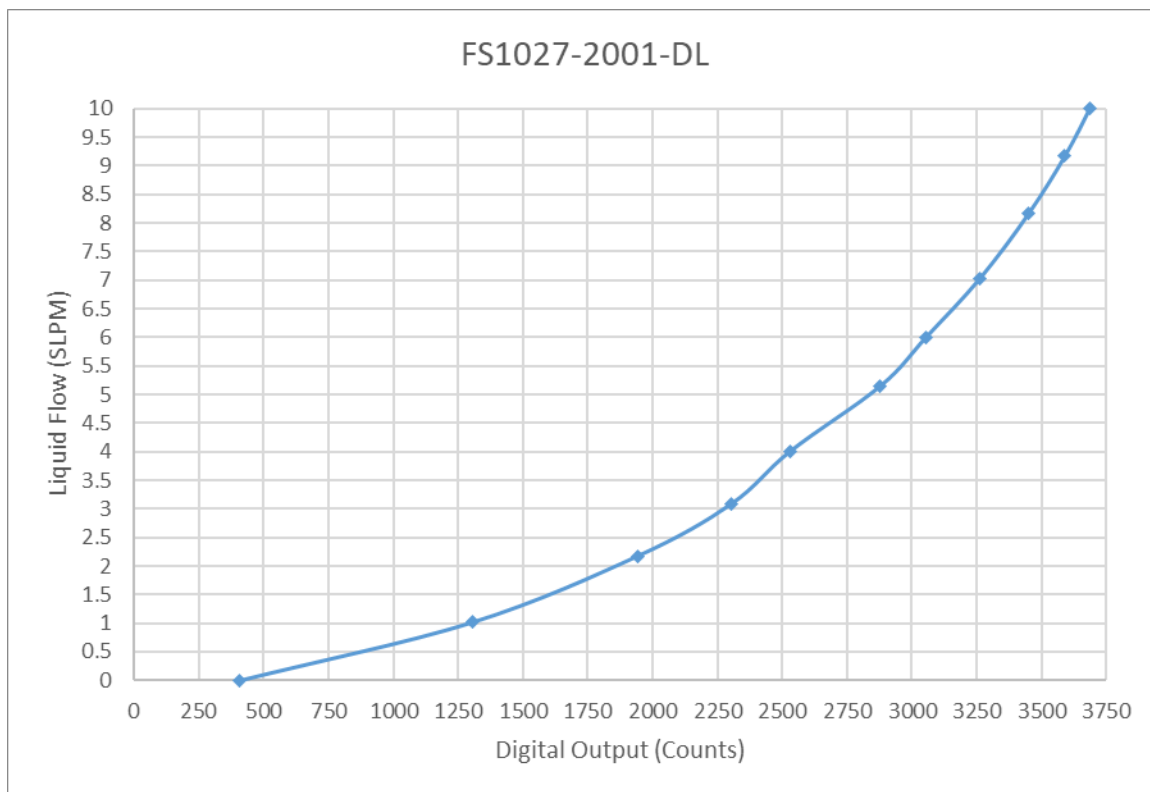

Figure 1. Digital Output Curve

Flow (Liters/min)	Digital Output (Counts)
0	409
1.016	1304
2.178	1943
3.086	2303
4.007	2530
5.152	2879
6.004	3055
7.038	3264
8.177	3452
9.172	3590
10.000	3686

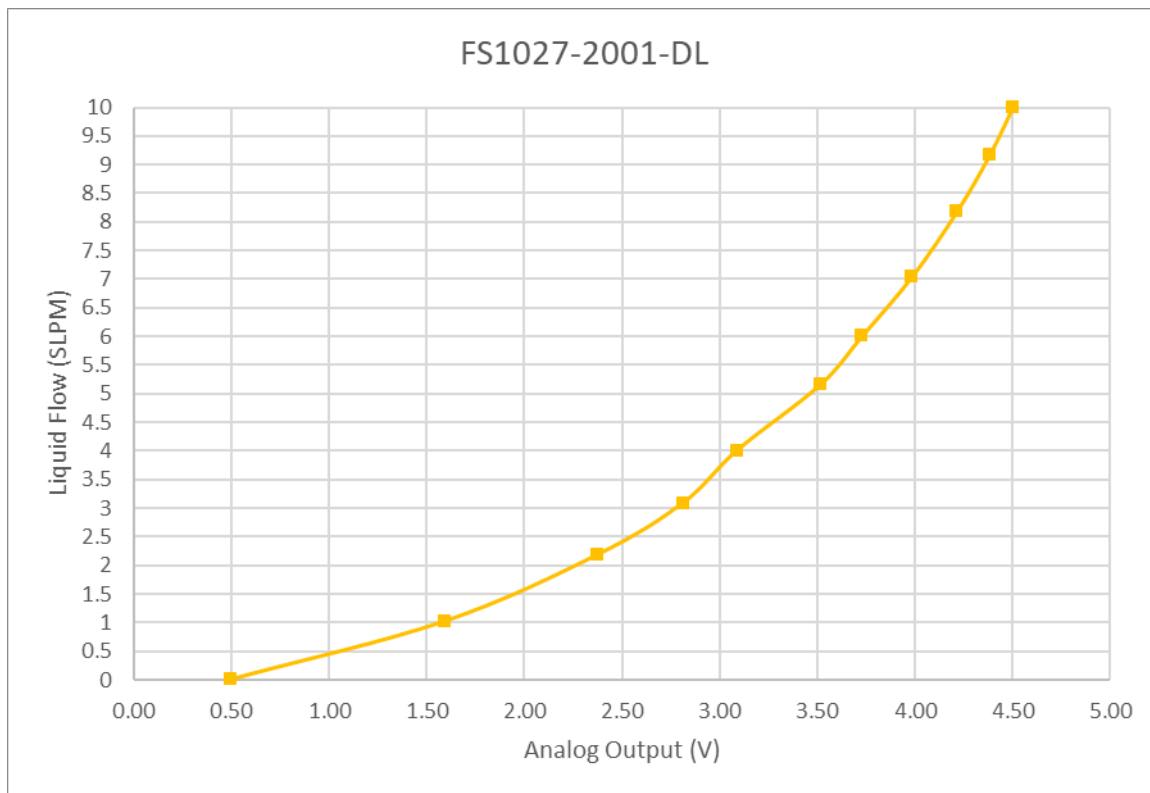

Figure 2. Analog Output Curve

Flow (Liters/min)	Analog Output (V)
0	0.50
1.016	1.59
2.178	2.37
3.086	2.81
4.007	3.09
5.152	3.51
6.004	3.73
7.038	3.98
8.177	4.21
9.172	4.38
10.000	4.50

4. I²C Sensor Interface

The FS1027-DL includes a digital I²C two-wire interface with a bidirectional data line (SDA) and a clock line (SCL). The two lines are open drain and connected to the supply voltage via two pull-up resistors (Rp). The FS1027-DL operates as a slave device on the I²C bus with support of 100kHz and 400kHz bit rates.

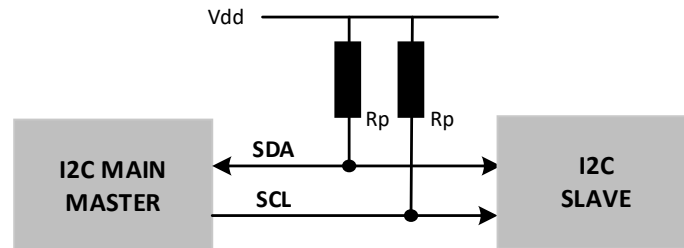

Figure 3. I²C Master-Slave Configuration

The recommended pull-up resistor (Rp) values depend on the system implementation; however, a value between 2.2kΩ and 10kΩ can be used.

The capacitive load on both SDA and SCL should be the same, therefore, the signal lengths should be similar to avoid asymmetry.

4.1 Sensor Slave Address

The FS1027-DL default I²C address is 50_{HEX}. The device will respond only to this **7-bit address**.

4.2 I²C Communication

The START condition is used to initiate I²C communication by the master. The sensor transmission is initiated when the master sends a 0 START bit (S). A HIGH to LOW transition on the SDA line while the SCL is HIGH indicates the beginning of a transmission.

The STOP condition is used to stop I²C communication by the master. The transmission is terminated when the master sends a 1 STOP bit (P). A LOW to HIGH transition on the SDA line while the SCL is HIGH indicates the end of a transmission.

All transfers consist of 8 bits and a response bit: 0 for Acknowledge (ACK) or 1 for Not Acknowledge (NACK). After the ACK is received, another data byte can be transferred or the communication can be stopped with a STOP bit.

The master expects an ACK back from the slave after each byte is transmitted. The slave pulls the SDA low to indicate that it has received a byte and then it frees the I²C bus again. If the slave does not initiate an ACK then it will consider it a NACK.

Data on the SDA line is always sampled on the rising edge of the SCL line and must remain stable while SCL is HIGH to prevent false START or STOP conditions.

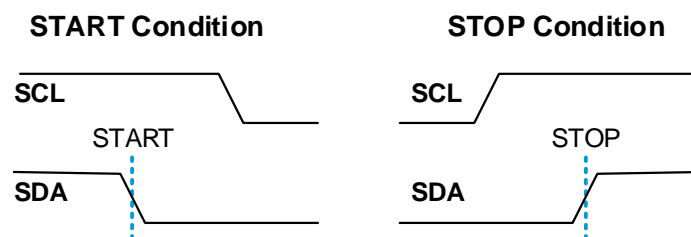

Figure 4. START and STOP Condition Waveform

4.3 Digital Output Measurements

The FS1027-DL continuously measures in operation.

The data is sent in byte packages. Each byte is followed by an ACK from the slave. The most significant bit (MSB) is transmitted first.

To read the data, the following command is sent to the FS1027-DL.

After the START bit, the master device sends the 7-bit slave address followed by an eighth bit = 1 (READ). The READ bit indicates a transmission from the FS1027-DL (slave) to master (see Figure 5).

The checksum used for data integrity is returned from the FS1027-DL followed by the two bytes of flow data.

The flow data is a 12-bit integer. Only the least significant four bits in the high byte are valid (see Figure 6).

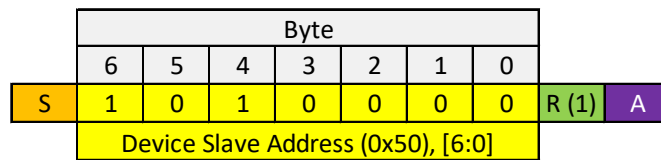
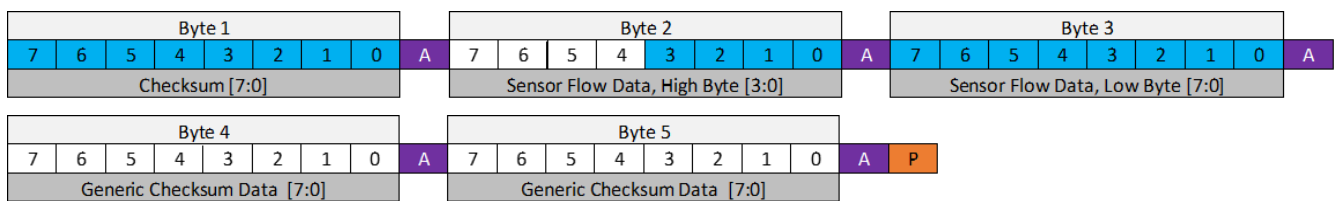

Figure 5. Flow Data Read Command



S START Condition

R READ Mode

P STOP Condition

A Acknowledge (ACK)

Figure 6. Flow Data from FS1027-DL

4.4 Calculating Checksum

The checksum used for data integrity is the 2's complement (negative) of the 256-modulo (8-bit) sum of the data bytes (does not include I²C address).

Figure 6 shows the 5 bytes read:

Example:

Byte 1, 0xCC (Checksum)

Byte 2, 0x01

Byte 3, 0x99

Byte 4, 0x01 or 0x00

Byte 5, 0x99 or 0x00

The 256-modulo (8-bit) sum is calculated as:

$$(EQ) 1 \quad sum = 0x01 + 0x99 + 0x01 + 0x99 = 0x134$$

Validating the data payload is done by calculating the sum and adding it to the checksum. If the result is 0x00, then the data is valid.

$$(EQ) 2 \quad checksum + sum = 0xCC + 0x134 = 0x00$$

4.5 Electrical Connector

A 6-position receptacle (not provided) is required to mate to the board crimp style connector. A part number example is PHR-6 (JST).

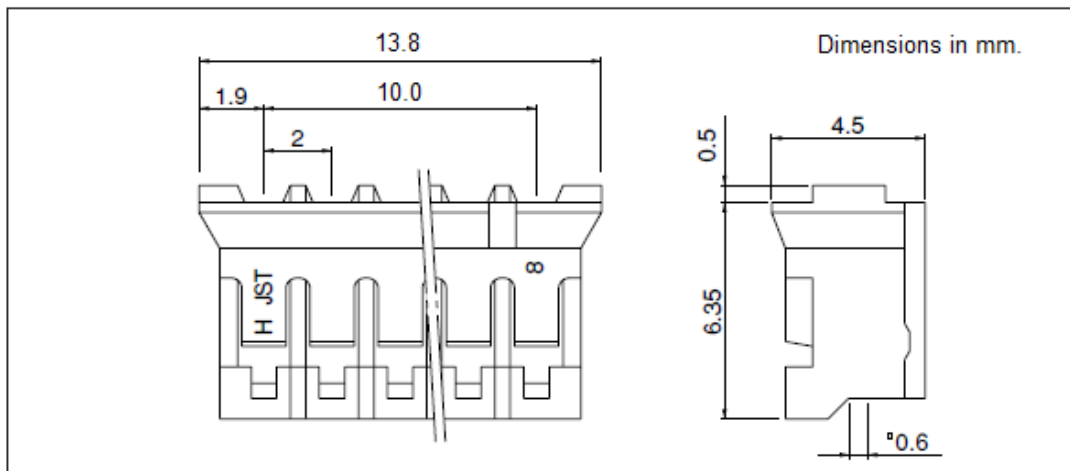

Figure 7. Receptacle Drawing

4.6 Module Material

The wetted contact surface of the FS1027-DL consists of the following:

- Housing – Polyphenylene Ether (PPE) + Polystyrene (PS) blend resin
- Parylene
- Gasket – Silicone

4.7 Tubing Guidance

The FS1027-DL module has barb tube endings. Soft tubing with a nominal 5/8-inch (15.88mm) internal diameter is recommended for use. A clamp may be necessary to secure the tubing over the barb.

5. Package Outline Drawings

The package outline drawings are located at the end of this document and are accessible from the Renesas website (see Ordering Information for POD links). The package information is the most current data available and is subject to change without revision of this document.

6. Ordering Information

Part Number	Package Description	Carrier Type	Temperature Range
FS1027-2001-DL	0 to 10 liter/min liquid flow sensor module with digital and analog voltage output (see MOD01)	Tray	0° to +70°C

7. Revision History

Revision	Date	Description
1.02	Sep 6, 2022	Updated reference with water.
1.01	Jul 1, 2021	Corrected current consumption, tubing guidance.
1.00	Mar 3, 2021	Initial release.

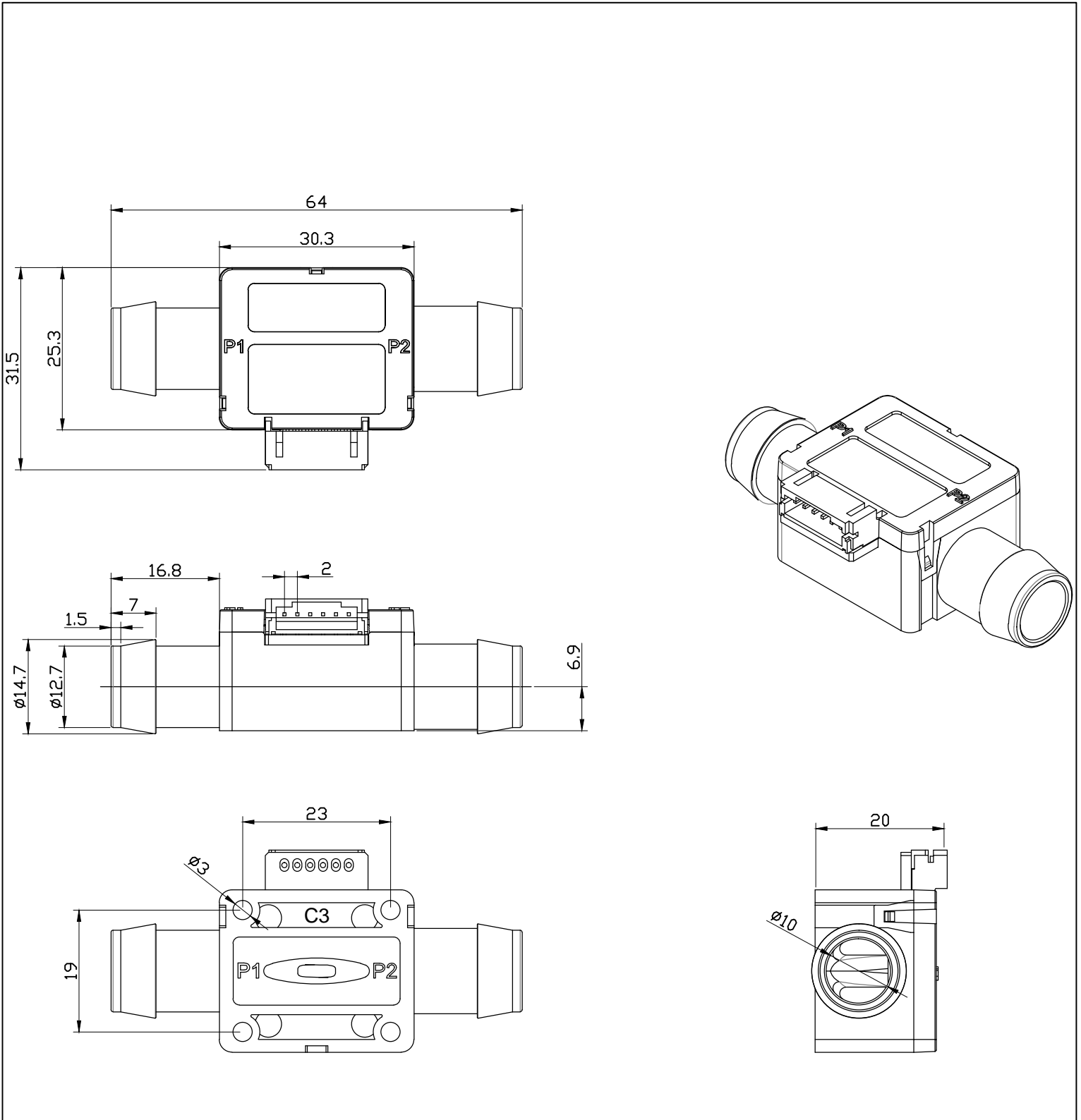

Package Revision History		
Date Created	Rev No.	Description
Nov 28, 2017	Rev 00	Initial Release

IMPORTANT NOTICE AND DISCLAIMER

RENESAS ELECTRONICS CORPORATION AND ITS SUBSIDIARIES (“RENESAS”) PROVIDES TECHNICAL SPECIFICATIONS AND RELIABILITY DATA (INCLUDING DATASHEETS), DESIGN RESOURCES (INCLUDING REFERENCE DESIGNS), APPLICATION OR OTHER DESIGN ADVICE, WEB TOOLS, SAFETY INFORMATION, AND OTHER RESOURCES “AS IS” AND WITH ALL FAULTS, AND DISCLAIMS ALL WARRANTIES, EXPRESS OR IMPLIED, INCLUDING, WITHOUT LIMITATION, ANY IMPLIED WARRANTIES OF MERCHANTABILITY, FITNESS FOR A PARTICULAR PURPOSE, OR NON-INFRINGEMENT OF THIRD-PARTY INTELLECTUAL PROPERTY RIGHTS.

These resources are intended for developers who are designing with Renesas products. You are solely responsible for (1) selecting the appropriate products for your application, (2) designing, validating, and testing your application, and (3) ensuring your application meets applicable standards, and any other safety, security, or other requirements. These resources are subject to change without notice. Renesas grants you permission to use these resources only to develop an application that uses Renesas products. Other reproduction or use of these resources is strictly prohibited. No license is granted to any other Renesas intellectual property or to any third-party intellectual property. Renesas disclaims responsibility for, and you will fully indemnify Renesas and its representatives against, any claims, damages, costs, losses, or liabilities arising from your use of these resources. Renesas' products are provided only subject to Renesas' Terms and Conditions of Sale or other applicable terms agreed to in writing. No use of any Renesas resources expands or otherwise alters any applicable warranties or warranty disclaimers for these products.

(Disclaimer Rev.1.01 Jan 2024)

Corporate Headquarters

TOYOSU FORESIA, 3-2-24 Toyosu,
Koto-ku, Tokyo 135-0061, Japan
www.renesas.com

Trademarks

Renesas and the Renesas logo are trademarks of Renesas Electronics Corporation. All trademarks and registered trademarks are the property of their respective owners.

Contact Information

For further information on a product, technology, the most up-to-date version of a document, or your nearest sales office, please visit www.renesas.com/contact-us/.