

To our customers,

Old Company Name in Catalogs and Other Documents

On April 1st, 2010, NEC Electronics Corporation merged with Renesas Technology Corporation, and Renesas Electronics Corporation took over all the business of both companies. Therefore, although the old company name remains in this document, it is a valid Renesas Electronics document. We appreciate your understanding.

Renesas Electronics website: <http://www.renesas.com>

April 1st, 2010
Renesas Electronics Corporation

Issued by: Renesas Electronics Corporation (<http://www.renesas.com>)

Send any inquiries to <http://www.renesas.com/inquiry>.

Notice

1. All information included in this document is current as of the date this document is issued. Such information, however, is subject to change without any prior notice. Before purchasing or using any Renesas Electronics products listed herein, please confirm the latest product information with a Renesas Electronics sales office. Also, please pay regular and careful attention to additional and different information to be disclosed by Renesas Electronics such as that disclosed through our website.
2. Renesas Electronics does not assume any liability for infringement of patents, copyrights, or other intellectual property rights of third parties by or arising from the use of Renesas Electronics products or technical information described in this document. No license, express, implied or otherwise, is granted hereby under any patents, copyrights or other intellectual property rights of Renesas Electronics or others.
3. You should not alter, modify, copy, or otherwise misappropriate any Renesas Electronics product, whether in whole or in part.
4. Descriptions of circuits, software and other related information in this document are provided only to illustrate the operation of semiconductor products and application examples. You are fully responsible for the incorporation of these circuits, software, and information in the design of your equipment. Renesas Electronics assumes no responsibility for any losses incurred by you or third parties arising from the use of these circuits, software, or information.
5. When exporting the products or technology described in this document, you should comply with the applicable export control laws and regulations and follow the procedures required by such laws and regulations. You should not use Renesas Electronics products or the technology described in this document for any purpose relating to military applications or use by the military, including but not limited to the development of weapons of mass destruction. Renesas Electronics products and technology may not be used for or incorporated into any products or systems whose manufacture, use, or sale is prohibited under any applicable domestic or foreign laws or regulations.
6. Renesas Electronics has used reasonable care in preparing the information included in this document, but Renesas Electronics does not warrant that such information is error free. Renesas Electronics assumes no liability whatsoever for any damages incurred by you resulting from errors in or omissions from the information included herein.
7. Renesas Electronics products are classified according to the following three quality grades: “Standard”, “High Quality”, and “Specific”. The recommended applications for each Renesas Electronics product depends on the product’s quality grade, as indicated below. You must check the quality grade of each Renesas Electronics product before using it in a particular application. You may not use any Renesas Electronics product for any application categorized as “Specific” without the prior written consent of Renesas Electronics. Further, you may not use any Renesas Electronics product for any application for which it is not intended without the prior written consent of Renesas Electronics. Renesas Electronics shall not be in any way liable for any damages or losses incurred by you or third parties arising from the use of any Renesas Electronics product for an application categorized as “Specific” or for which the product is not intended where you have failed to obtain the prior written consent of Renesas Electronics. The quality grade of each Renesas Electronics product is “Standard” unless otherwise expressly specified in a Renesas Electronics data sheets or data books, etc.
 - “Standard”: Computers; office equipment; communications equipment; test and measurement equipment; audio and visual equipment; home electronic appliances; machine tools; personal electronic equipment; and industrial robots.
 - “High Quality”: Transportation equipment (automobiles, trains, ships, etc.); traffic control systems; anti-disaster systems; anti-crime systems; safety equipment; and medical equipment not specifically designed for life support.
 - “Specific”: Aircraft; aerospace equipment; submersible repeaters; nuclear reactor control systems; medical equipment or systems for life support (e.g. artificial life support devices or systems), surgical implantations, or healthcare intervention (e.g. excision, etc.), and any other applications or purposes that pose a direct threat to human life.
8. You should use the Renesas Electronics products described in this document within the range specified by Renesas Electronics, especially with respect to the maximum rating, operating supply voltage range, movement power voltage range, heat radiation characteristics, installation and other product characteristics. Renesas Electronics shall have no liability for malfunctions or damages arising out of the use of Renesas Electronics products beyond such specified ranges.
9. Although Renesas Electronics endeavors to improve the quality and reliability of its products, semiconductor products have specific characteristics such as the occurrence of failure at a certain rate and malfunctions under certain use conditions. Further, Renesas Electronics products are not subject to radiation resistance design. Please be sure to implement safety measures to guard them against the possibility of physical injury, and injury or damage caused by fire in the event of the failure of a Renesas Electronics product, such as safety design for hardware and software including but not limited to redundancy, fire control and malfunction prevention, appropriate treatment for aging degradation or any other appropriate measures. Because the evaluation of microcomputer software alone is very difficult, please evaluate the safety of the final products or system manufactured by you.
10. Please contact a Renesas Electronics sales office for details as to environmental matters such as the environmental compatibility of each Renesas Electronics product. Please use Renesas Electronics products in compliance with all applicable laws and regulations that regulate the inclusion or use of controlled substances, including without limitation, the EU RoHS Directive. Renesas Electronics assumes no liability for damages or losses occurring as a result of your noncompliance with applicable laws and regulations.
11. This document may not be reproduced or duplicated, in any form, in whole or in part, without prior written consent of Renesas Electronics.
12. Please contact a Renesas Electronics sales office if you have any questions regarding the information contained in this document or Renesas Electronics products, or if you have any other inquiries.

(Note 1) “Renesas Electronics” as used in this document means Renesas Electronics Corporation and also includes its majority-owned subsidiaries.

(Note 2) “Renesas Electronics product(s)” means any product developed or manufactured by or for Renesas Electronics.

HD26LS32

Quadruple Differential Line Receivers With 3 State Outputs

REJ03D0295-0200Z
 (Previous ADE-205-577 (Z))
 Rev.2.00
 Jul.16.2004

Description

The HD26LS32 features quadruple line receivers designed to meet the specs of EIA standard RS-422A and RS-423. This device operates from a single 5 V power supply. The enable function is common to all four receivers and offers a choice of active high or active low input. Fail safe design ensures that if the inputs are open, the outputs will always be high.

Features

- Ordering Information

Part Name	Package Type	Package Code	Package Abbreviation	Taping Abbreviation (Quantity)
HD26LS32P	DILP-16 pin (JEITA)	DP-16E, -16FV	P	—
HD26LS32FPEL	SOP-16 pin (JEITA)	FP-16DAV	FP	EL (2,000 pcs/reel)

Note: Please consults the sales office for the above package availability.

Logic Diagram

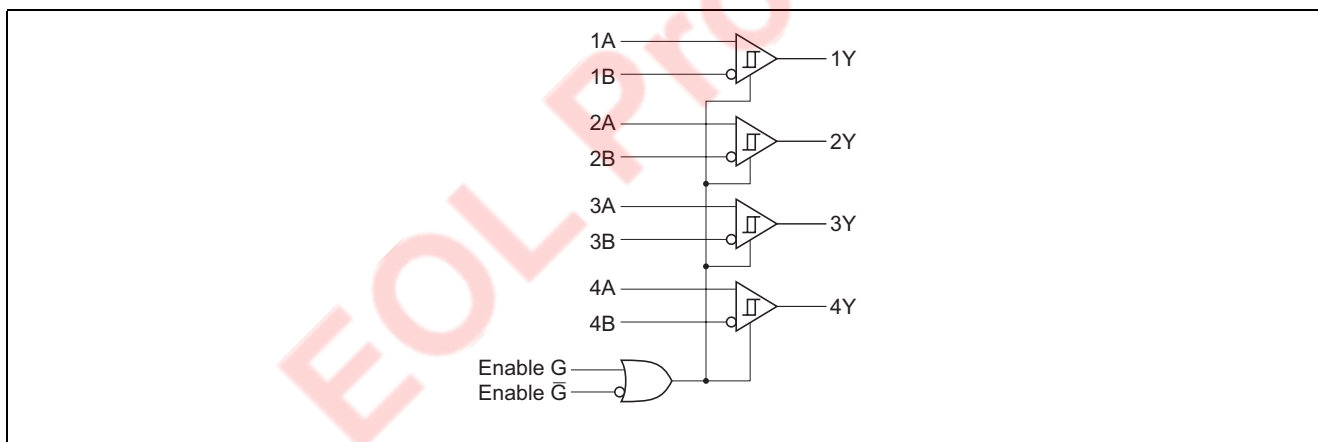

Pin Arrangement

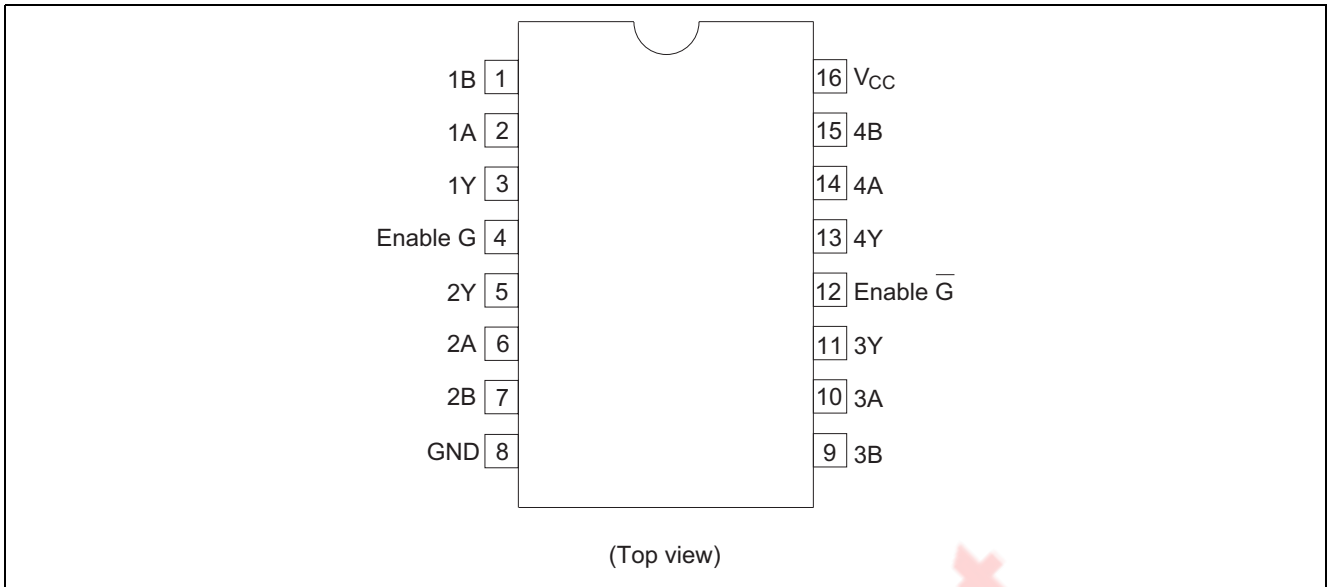

Function Table

Differential Input A – B	Enable		Output Y
	G	Ḡ	
$V_{ID} \geq V_{TH}$	H	X	H
	X	L	H
$V_{TL} < V_{ID} < V_{TH}$	H	X	?
	X	L	?
$V_{ID} \leq V_{TL}$	H	X	L
	X	L	L
X	L	H	Z

- H : High level
- L : Low level
- X : Immaterial
- ? : Irrelevant
- Z : High impedance

Absolute Maximum Ratings

Item	Symbol	Ratings	Unit
Supply Voltage	V_{CC}^{*1}	7.0	V
In Phase Input Voltage	V_{IC}	± 25	V
Differential Input Voltage	V_{ID}^{*2}	± 25	V
Enable Input Voltage	V_{IN}	7	V
Output Sink Current	I_{out}	50	mA
Continuous Total Dissipation	P_T	1	W
Operating Temperature Range	T_{opr}	0 to +70	$^{\circ}C$
Storage Temperature Range	T_{stg}	-65 to 150	$^{\circ}C$

- Notes: 1. All voltage values except for differential input voltage are with respect to network ground terminal.
 2. Differential input voltage is measured at the noninverting input with respect to the corresponding inverting output.
 3. The absolute maximum ratings are values which must not individually be exceeded, and furthermore, no two of which may be realized at the same time.

Recommended Operating Conditions

Item	Symbol	Min	Typ	Max	Unit
Supply Voltage	V_{CC}	4.75	5.00	5.25	V
In Phase Input Voltage	V_{IC}	—	—	± 7.0	V
Output Current	I_{OH}	—	—	-440	μA
	I_{OL}	—	—	8	mA
Operating Temperature	T_{opr}	0	—	70	$^{\circ}C$

Electrical Characteristics (Ta = 0 to +70°C)

Item	Symbol	Min	Typ*1	Max	Unit	Conditions	
Differential Input High Threshold Voltage	V_{TH}	—	—	0.2	V	$V_{IC} = -7$ to $+7$ V $V_{OH} = 2.7$ V, $I_{OH} = -440$ μ A	
Differential Input Low Threshold Voltage	V_{TL}	—	—	-0.2			$V_{OL} = 0.4$ V, $I_{OL} = 4$ mA
		—	—	-0.2			$V_{OL} = 0.45$ V, $I_{OL} = 8$ mA
Input Hysteresis*2	$V_{TH} - V_{TL}$	—	30	—	mV		
Enable Input Voltage	V_{IH}	2.0	—	—	V		
	V_{IL}	—	—	0.8			
Enable Input Clamp Voltage	V_{IK}	—	—	1.5		$V_{CC} = 4.75$ V, $I_{IN} = -18$ mA	
Output Voltage	V_{OH}	2.7	—	—		$V_{CC} = 4.75$ V $V_{ID} = 1$ V, $I_{OH} = -440$ μ A	
	V_{OL}	—	—	0.4		$V_{IL} (\bar{G}) = 0.8$ V $V_{ID} = -1$ V, $I_{OL} = 4$ mA	
		—	—	0.45		$V_{ID} = -1$ V, $I_{OL} = 8$ mA	
Off State (High Impedance) Output Current	I_{OZ}	—	—	20	μ A	$V_{CC} = 5.25$ V $V_O = 2.4$ V	
		—	—	-20		$V_O = 0.4$ V	
Line Input Current	I_I	—	—	2.3 2.8	mA	$V_I = 15$ V, Other Inputs -10 to $+15$ V $V_I = -15$ V, Other Inputs -15 to $+10$ V	
Enable Input Current	I_I (EN)	—	—	100	μ A	$V_I = 5.5$ V	
	I_{IH}	—	—	20		$V_I = 2.7$ V	
	I_{IL}	—	—	-0.36		$V_I = 0.4$ V	
Input Resistance	r_i	6	9.8	—	k Ω	$V_{IC} = -15$ to $+15$ V (Other Inputs AC GND)	
Short Circuit Output Current	I_{OS} *3	-15	—	-85	mA	$V_{CC} = 5.25$ V	
Supply Current	I_{CC}	—	52	70		$V_{CC} = 5.25$ V, $V_I = 0$ V (All Outputs Disable)	

Notes: 1. All typical values are at $V_{CC} = 5$ V, $T_a = 25^\circ\text{C}$, $V_{IC} = 0$.

2. Hysteresis is the differential between the positive going input threshold voltage and the negative going input threshold voltage.

3. Not more than one output should be shorted at a time.

Switching Characteristics ($V_{CC} = 5$ V, $T_a = 25^\circ\text{C}$)

Item	Symbol	Min	typ	Max	Unit	Conditions
Propagation Delay Time	t_{PLH} , t_{PHL}	—	17	25	ns	$C_L = 15$ pF
Output Enable Time	t_{ZH} , t_{ZL}	—	15	22		
Output Disable Time	t_{HZ}	—	15	22		
	t_{LZ}	—	20	30		

1. t_{PLH} , t_{PHL}

Test circuit

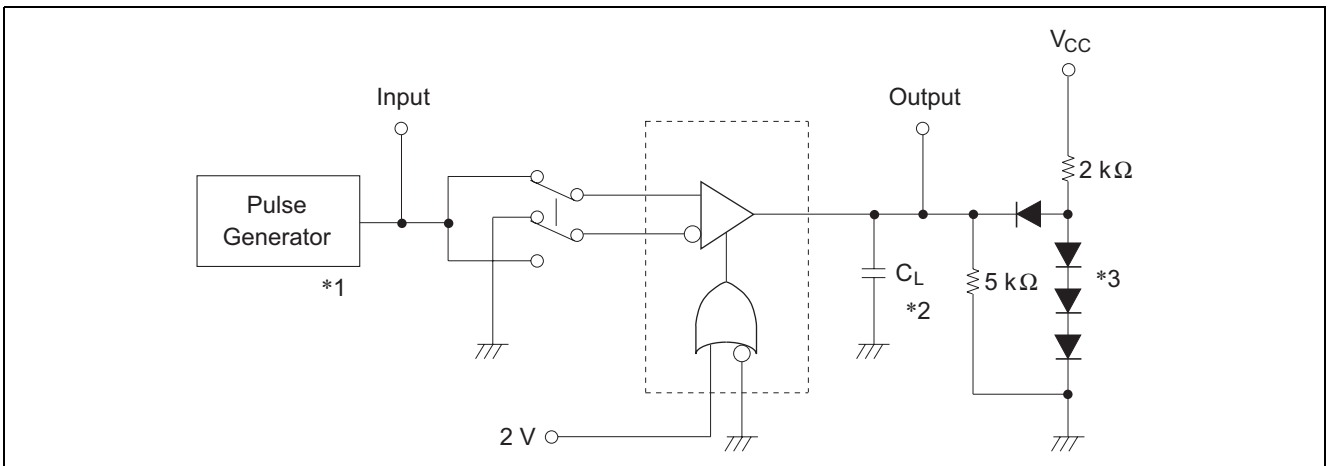

Waveforms

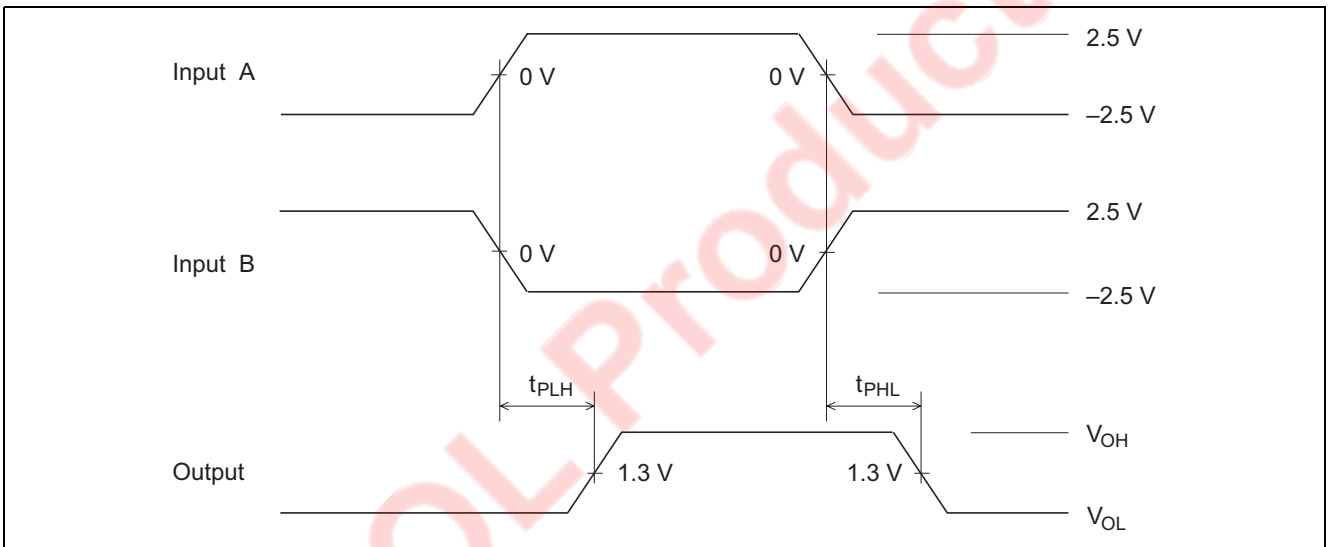

2. t_{HZ} , t_{ZH}

Test circuit

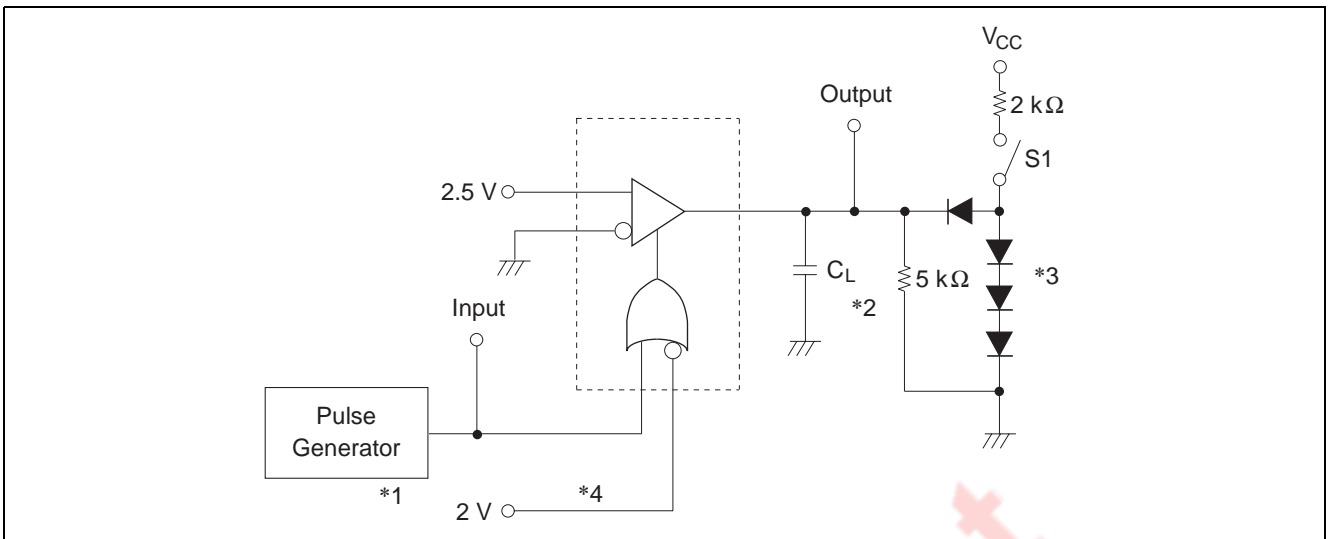

Waveforms

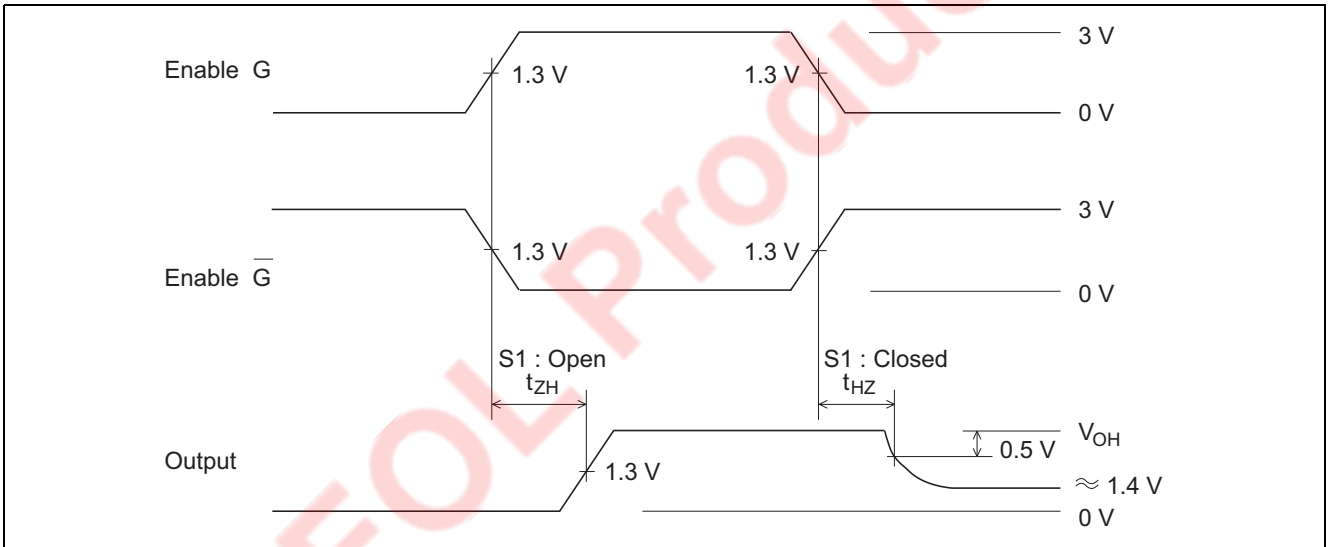

3. t_{LZ} , t_{ZL}

Test circuit

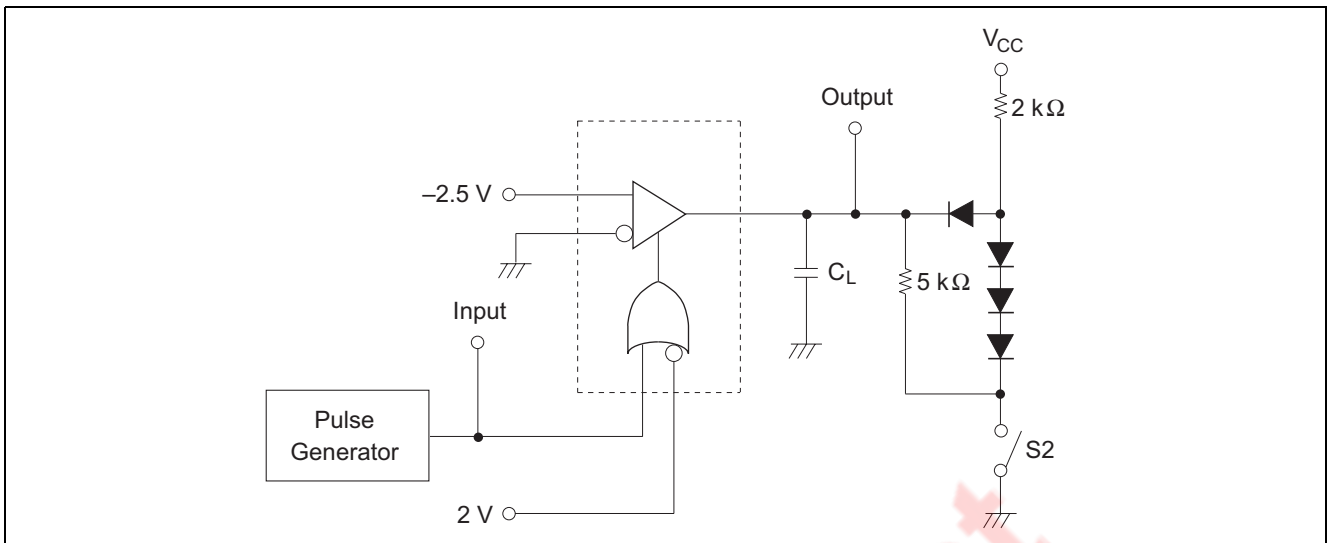

Waveforms

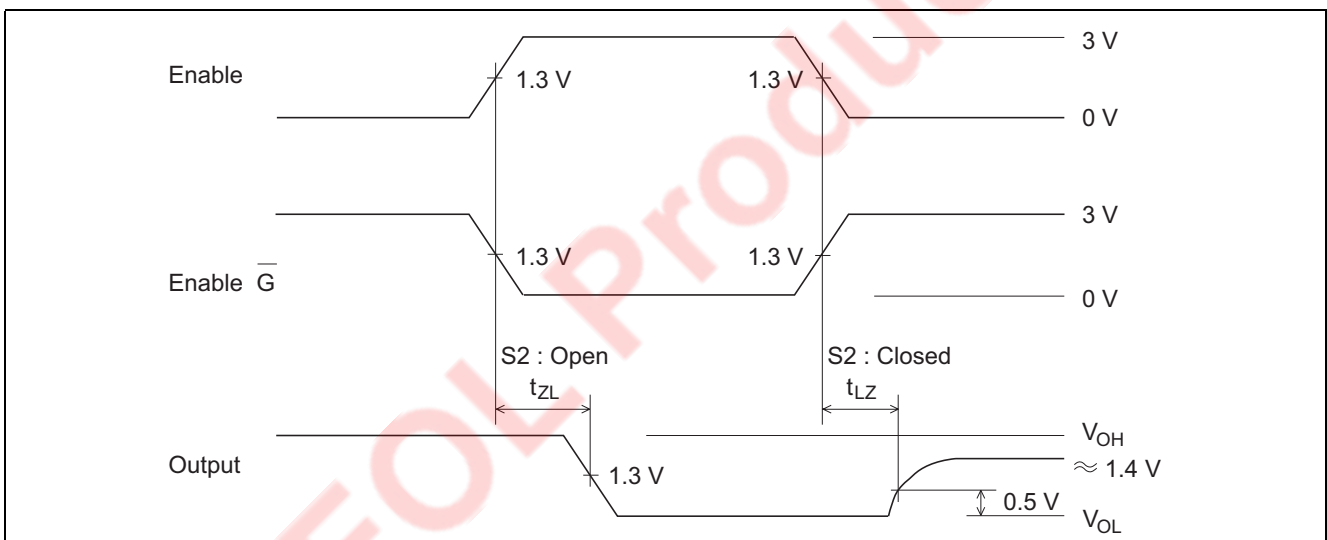

- Notes:
1. The pulse generator has the following characteristics :
 PRR = 1 MHz, 50 % duty cycle, $t_r \leq 15$ ns, $t_f \leq 6$ ns, $Z_{out} = 50 \Omega$.
 2. C_L includes probe and jig capacitance.
 3. All diodes are 1S2074 (H)
 4. To test G input, ground G input and apply an inverted input waveform.

HD26LS32 Line Receiver Applications

The HD26LS32 is a line receiver that meets the EIA RS-422A and RS-423A conditions. It has a high in-phase input voltage range, both positive and negative, enabling highly reliable transmission to be performed even in noisy environments.

Its main features are listed below.

- Operates on a single 5 V power supply.
- Three-state output
- On-chip fail-safe circuit
- ± 7 V in-phase input voltage range
- ± 200 mV input sensitivity
- Minimum 6 k Ω input resistance

A block diagram is shown in figure 1. The enable function is common to all four drivers, and either active-high or active-low input can be selected.

When exchange is carried out using a party line system, it is better to keep the receiver input bias current constituting the driver load small, as this allows more receivers to be connected.

Consequently, whereas an input resistance of 4 k Ω or above is stipulated in RS-422A and RS-423A, the HD26LS32 has been designed to allow a greater margin, with a minimum resistance of 6 k Ω .

Figure 2 shows the input current characteristics of the HD26LS32.

The shaded areas in the graph indicate the input current allowable range stipulated in RS-422A and RS-423A.

HD26LS32 output is LS-TTL compatible and has a three-state function, enabling the output to be placed in the high-impedance state, and so making the device suitable for bus line type applications.

With an in-phase input voltage range of ± 7 V and a ± 200 mV input sensitivity, the HD26LS32 can withstand use in noisy environments.

Also, since signals sent over a long-distance transmission line require a long transition time, it also takes a long time to cross the receiver's input threshold level.

Therefore, the input is provided with hysteresis of around 30 mV to prevent receiver output misoperation due to noise.

An example of input hysteresis is shown in figure 3.

The fail-safe function consists of resistances R connecting input A to V_{CC} and input B to GND, as shown in figure 4.

This circuit provides for the receiver input section to be pulled up or down by a high resistance that prevents it from becoming a driver load so that the output goes high in the event of a transmission line breakage or connector detachment.

When the input pin is placed in the open state by the pull-up/pull-down resistance, the differential input voltage V_{ID} is as follows:

$$V_{ID}: (V_{IA} - V_{IB}) \geq 0.2 \text{ V}$$

and the output is fixed high.

However, if the receiver-side termination resistance remains connected despite a line breakage or connector detachment, the output will be undetermined (figure 5).

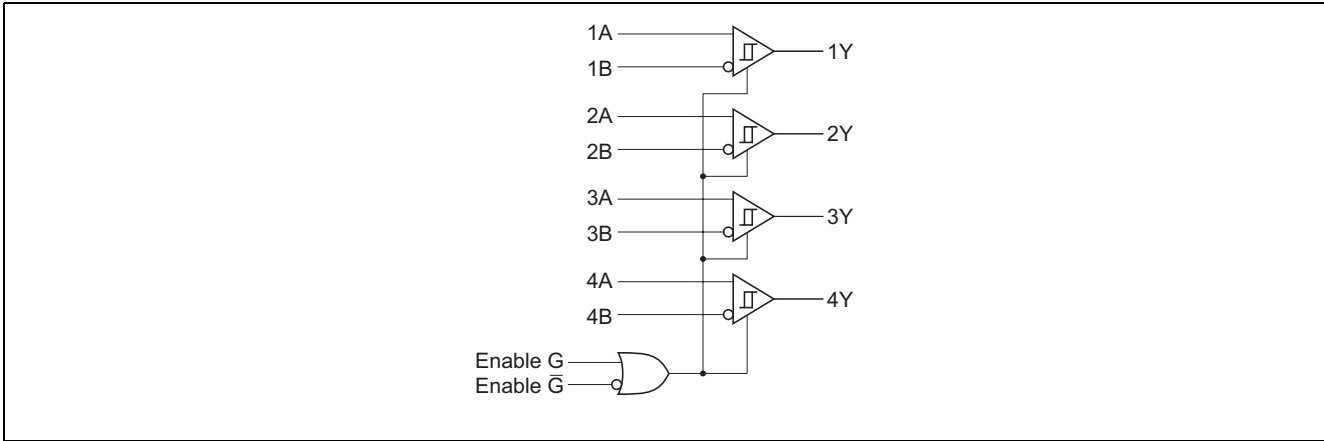

Figure 1 HD26LS32 Block Diagram

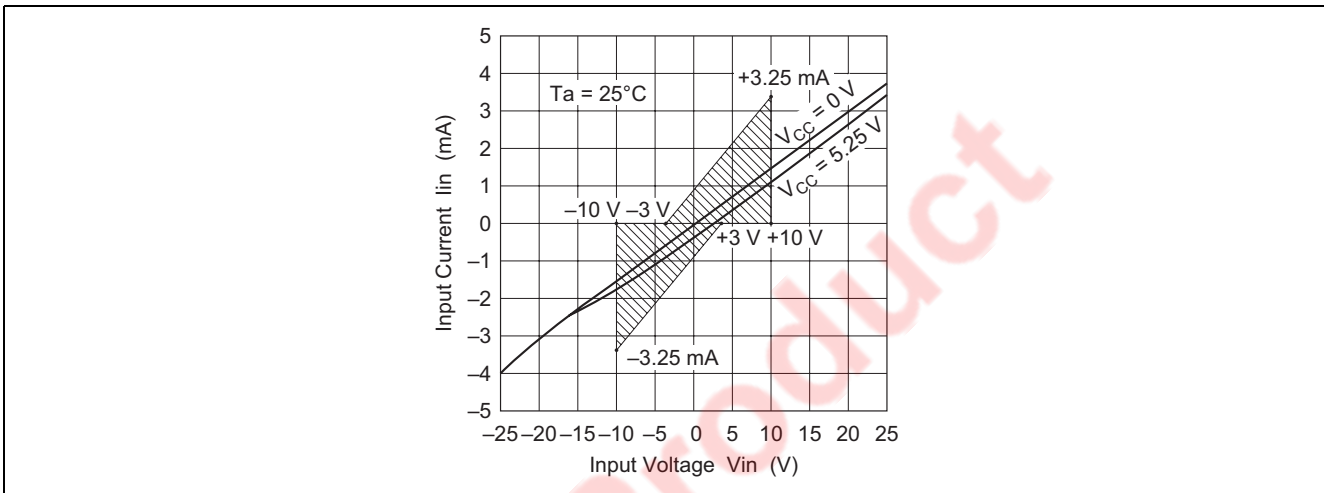

Figure 2 Input Voltage vs. Input Current Characteristics

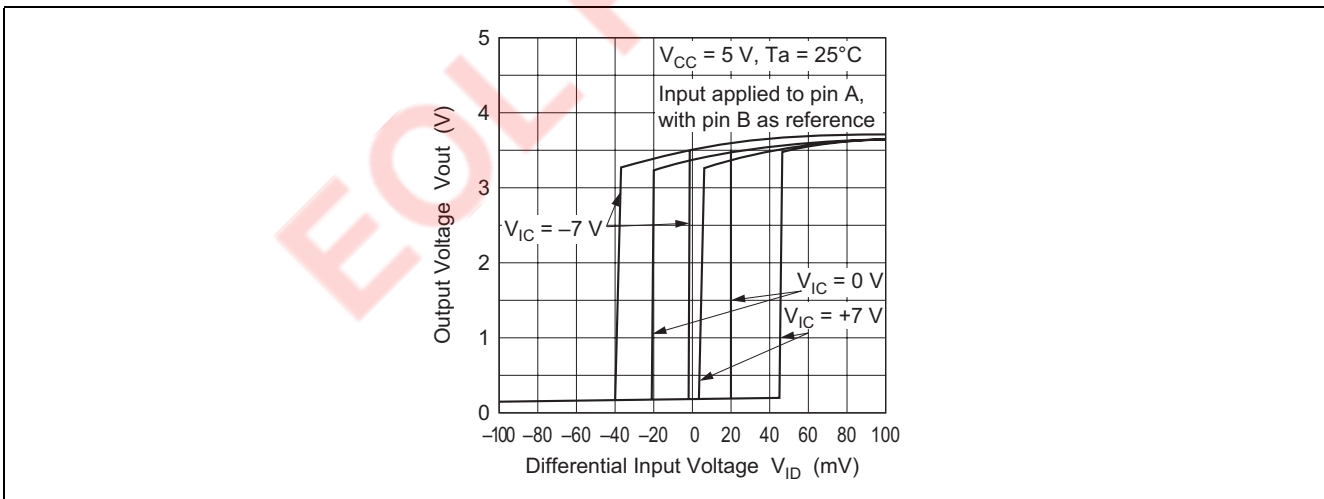

Figure 3 Differential Input Voltage vs. Output Voltage Characteristics

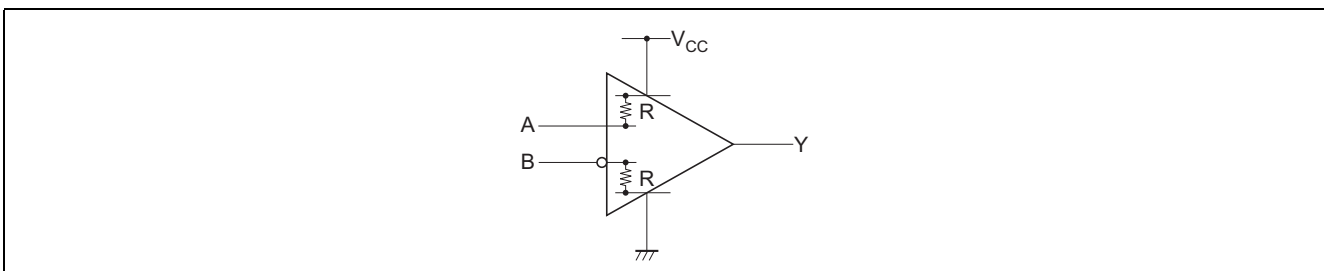

Figure 4 Fail-Safe Function

This is because, since the termination resistance is normally matched to the transmission line characteristic impedance, the value falls to several tens of hundreds of ohms, and the differential input pins are shorted by this termination resistance. That is, the differential input voltage V_{ID} comes within the range

$$V_{ID}: -0.2 \text{ V} < V_{IA} - V_{IB} < 0.2 \text{ V}$$

and the output becomes undetermined.

To prevent this, resistance R_1 is inserted in series with the transmission line as shown in figure 6, minimizing the effect of the termination resistance. Resistance R_2 is added to increase the current flowing between the termination resistance and R_1 , enabling the value of R_1 to be kept small.

Inserting resistances R_1 and R_2 in this way provides for the differential input voltage V_{ID} to become 200 mV or higher, but the following points must be noted.

- Smallest possible R_1 value
If this value is large, the receiver input sensitivity will fall.
- Largest possible R_2 value
If this value is small, the load on the driver will be large.

Figure 7 shows experimental differential input voltages for variations in R_1 and R_2 .

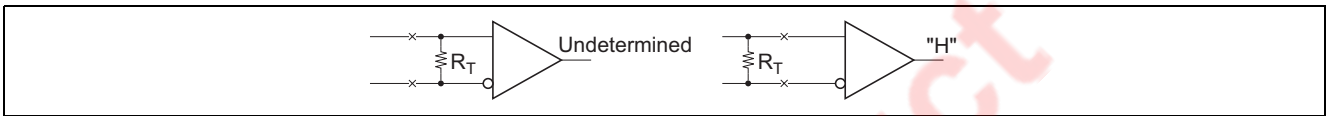

Figure 5 Examples of Transmission Line Disconnection

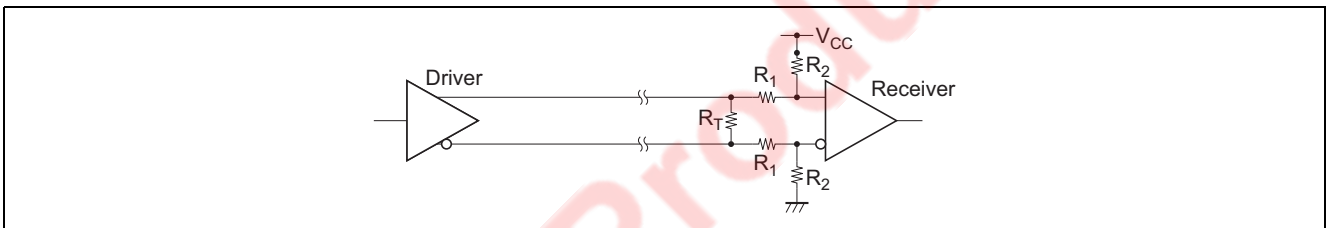

Figure 6 Method of Enhancing Fail-Safe Function

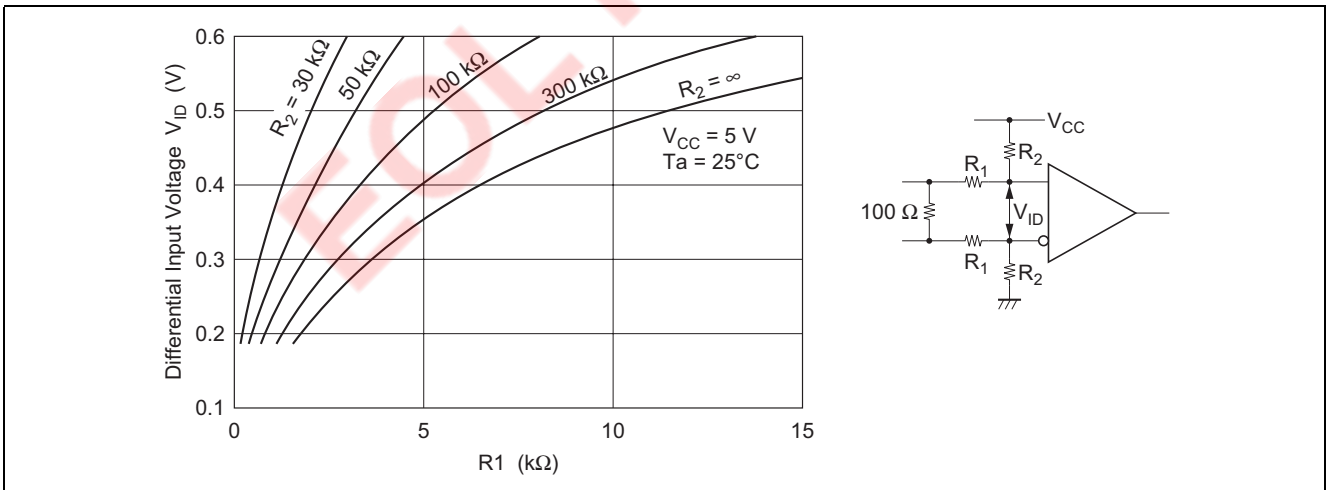

Figure 7 R_1, R_2 vs. Differential Input Voltage

RS-442A Interface Standard Applications

Figure 9 shows sample operation waveforms at various points with 1200 m and 12 m cable lengths.

1. Unidirectional Transmission (1 : 1 Configuration)

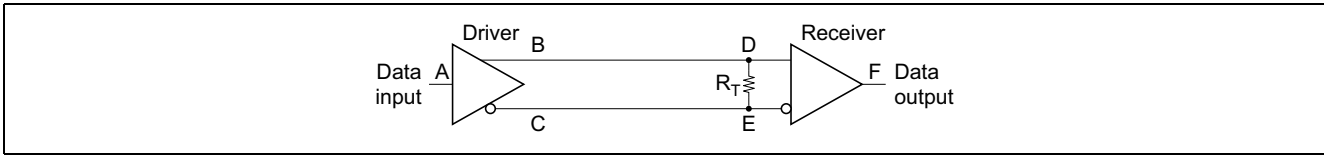

Figure 8 1 : 1 Unidirectional Transmission

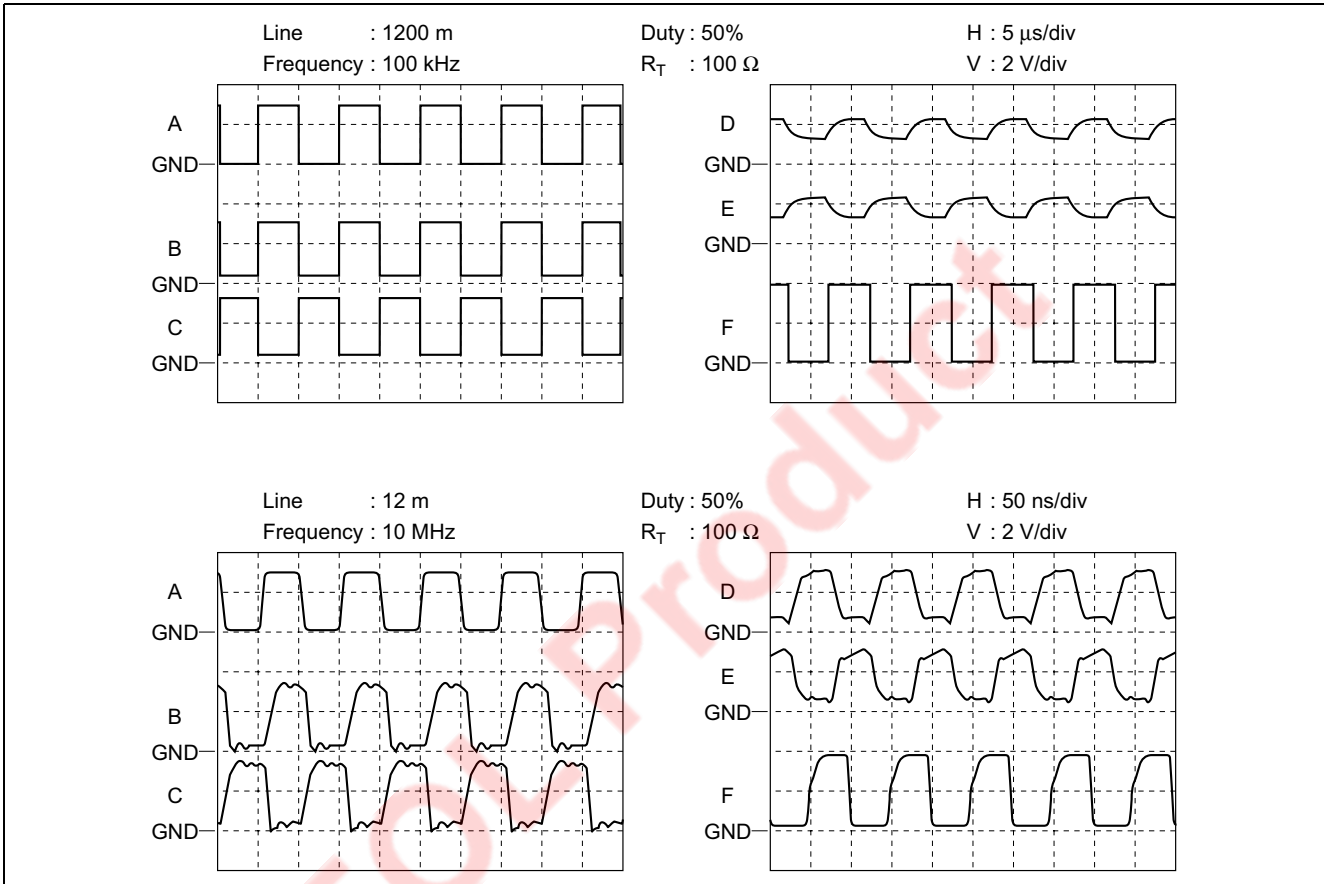

Figure 9 Sample Transmission Waveforms

2. Unidirectional Transmission (1 : n Configuration)

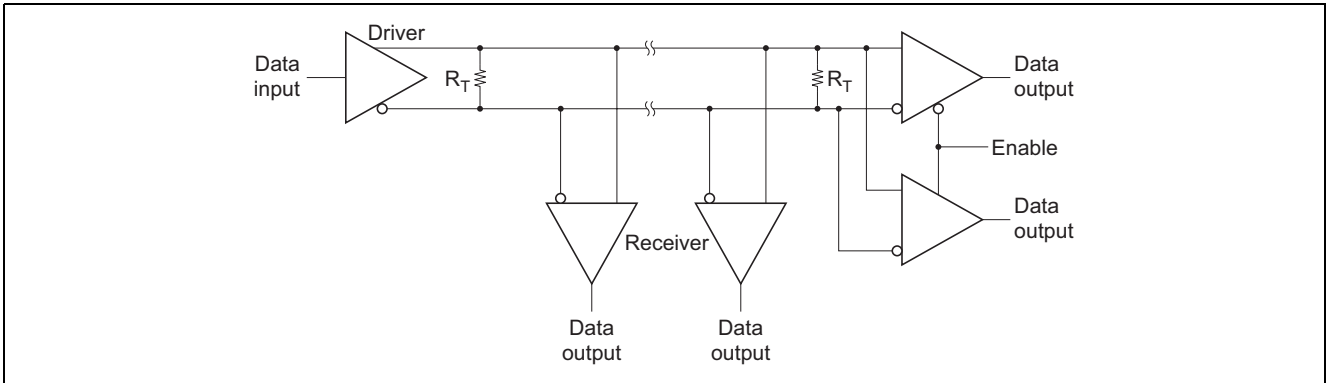

Figure 10 1 : n Unidirectional Transmission

With this connection method, n receivers are connected for one driver. In the RS-422A standard, ten receivers can be connected simultaneously for one driver.

Conversely, it is also possible to connect one receiver for n drivers.

3. Bidirectional Transmission

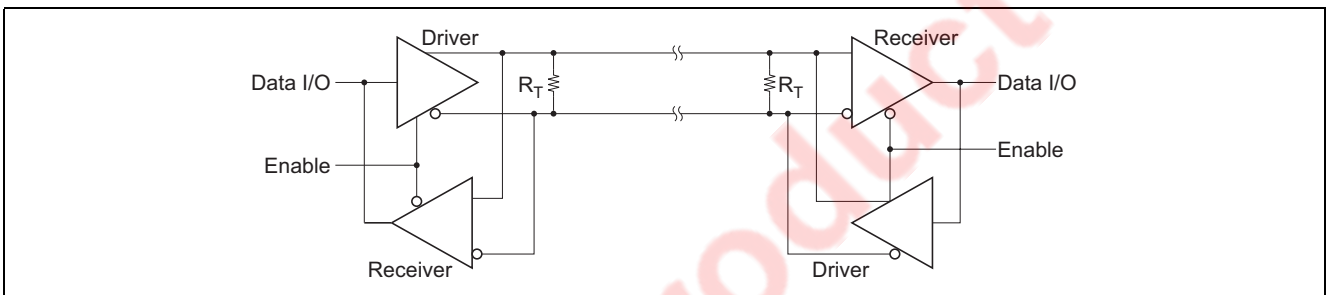

Figure 11 Bidirectional Transmission

When bidirectional data exchange is performed using a combination of the HD26LS31 and HD26LS32, since either high or low output control is possible, using complementary enable inputs for the driver and receiver makes it easy to configure the kind of combination illustrated in figure 11 .

Extending this combination makes it possible to exchange n-bit data simultaneously, and handle a party line system.

Package Dimensions

As of January, 2003
Unit: mm

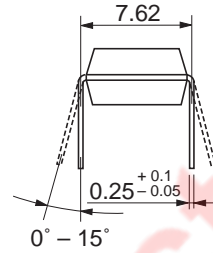
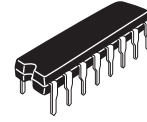
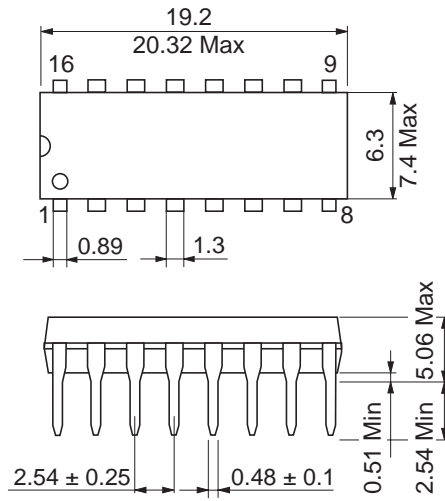

Package Code	DP-16E
JEDEC	Conforms
JEITA	Conforms
Mass (reference value)	1.05 g

Unit: mm

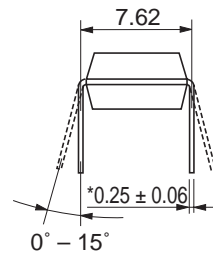
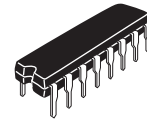
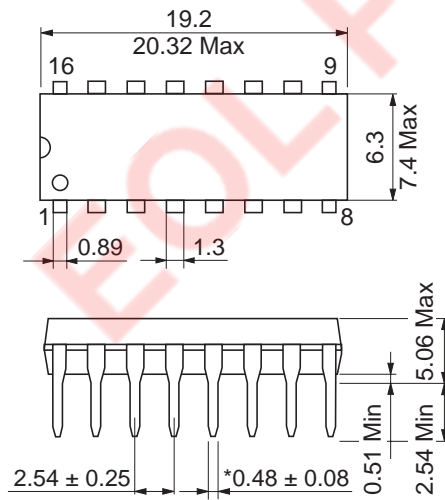

*NI/Pd/AU Plating

Package Code	DP-16FV
JEDEC	Conforms
JEITA	Conforms
Mass (reference value)	1.05 g

As of January, 2003

Unit: mm

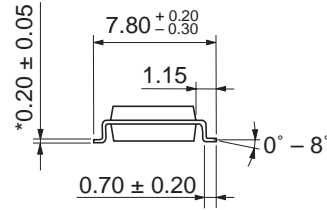
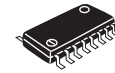
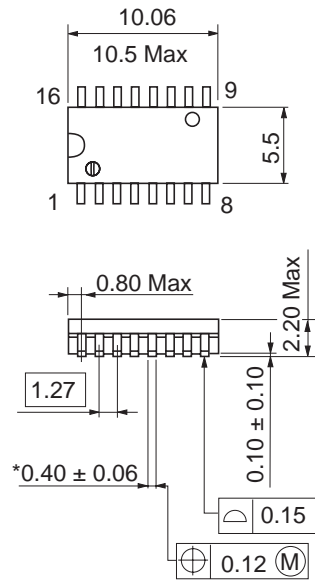

*Ni/Pd/Au plating

Package Code	FP-16DAV
JEDEC	—
JEITA	Conforms
Mass (reference value)	0.24 g

EOL Product

Renesas Technology Corp. Sales Strategic Planning Div. Nippon Bldg., 2-6-2, Ohte-machi, Chiyoda-ku, Tokyo 100-0004, Japan

Keep safety first in your circuit designs!

1. Renesas Technology Corp. puts the maximum effort into making semiconductor products better and more reliable, but there is always the possibility that trouble may occur with them. Trouble with semiconductors may lead to personal injury, fire or property damage. Remember to give due consideration to safety when making your circuit designs, with appropriate measures such as (i) placement of substitutive, auxiliary circuits, (ii) use of nonflammable material or (iii) prevention against any malfunction or mishap.

Notes regarding these materials

1. These materials are intended as a reference to assist our customers in the selection of the Renesas Technology Corp. product best suited to the customer's application; they do not convey any license under any intellectual property rights, or any other rights, belonging to Renesas Technology Corp. or a third party.
 2. Renesas Technology Corp. assumes no responsibility for any damage, or infringement of any third-party's rights, originating in the use of any product data, diagrams, charts, programs, algorithms, or circuit application examples contained in these materials.
 3. All information contained in these materials, including product data, diagrams, charts, programs and algorithms represents information on products at the time of publication of these materials, and are subject to change by Renesas Technology Corp. without notice due to product improvements or other reasons. It is therefore recommended that customers contact Renesas Technology Corp. or an authorized Renesas Technology Corp. product distributor for the latest product information before purchasing a product listed herein.
The information described here may contain technical inaccuracies or typographical errors.
Renesas Technology Corp. assumes no responsibility for any damage, liability, or other loss rising from these inaccuracies or errors.
Please also pay attention to information published by Renesas Technology Corp. by various means, including the Renesas Technology Corp. Semiconductor home page (<http://www.renesas.com>).
 4. When using any or all of the information contained in these materials, including product data, diagrams, charts, programs, and algorithms, please be sure to evaluate all information as a total system before making a final decision on the applicability of the information and products. Renesas Technology Corp. assumes no responsibility for any damage, liability or other loss resulting from the information contained herein.
 5. Renesas Technology Corp. semiconductors are not designed or manufactured for use in a device or system that is used under circumstances in which human life is potentially at stake. Please contact Renesas Technology Corp. or an authorized Renesas Technology Corp. product distributor when considering the use of a product contained herein for any specific purposes, such as apparatus or systems for transportation, vehicular, medical, aerospace, nuclear, or undersea repeater use.
 6. The prior written approval of Renesas Technology Corp. is necessary to reprint or reproduce in whole or in part these materials.
 7. If these products or technologies are subject to the Japanese export control restrictions, they must be exported under a license from the Japanese government and cannot be imported into a country other than the approved destination.
Any diversion or reexport contrary to the export control laws and regulations of Japan and/or the country of destination is prohibited.
 8. Please contact Renesas Technology Corp. for further details on these materials or the products contained therein.
-



RENESAS SALES OFFICES

<http://www.renesas.com>

Renesas Technology America, Inc.

450 Holger Way, San Jose, CA 95134-1368, U.S.A
Tel: <1> (408) 382-7500 Fax: <1> (408) 382-7501

Renesas Technology Europe Limited.

Dukes Meadow, Millboard Road, Bourne End, Buckinghamshire, SL8 5FH, United Kingdom
Tel: <44> (1628) 585 100, Fax: <44> (1628) 585 900

Renesas Technology Europe GmbH

Dornacher Str. 3, D-85622 Feldkirchen, Germany
Tel: <49> (89) 380 70 0, Fax: <49> (89) 929 30 11

Renesas Technology Hong Kong Ltd.

7/F., North Tower, World Finance Centre, Harbour City, Canton Road, Hong Kong
Tel: <852> 2265-6688, Fax: <852> 2375-6836

Renesas Technology Taiwan Co., Ltd.

FL 10, #99, Fu-Hsing N. Rd., Taipei, Taiwan
Tel: <886> (2) 2715-2888, Fax: <886> (2) 2713-2999

Renesas Technology (Shanghai) Co., Ltd.

26/F., Ruijin Building, No.205 Maoming Road (S), Shanghai 200020, China
Tel: <86> (21) 6472-1001, Fax: <86> (21) 6415-2952

Renesas Technology Singapore Pte. Ltd.

1, Harbour Front Avenue, #06-10, Keppel Bay Tower, Singapore 098632
Tel: <65> 6213-0200, Fax: <65> 6278-8001