

HIP6004

Buck and Synchronous-Rectifier (PWM) Controller and Output Voltage Monitor

FN4275
Rev.2.00
March 2000

The HIP6004 provides complete control and protection for a DC-DC converter optimized for high-performance microprocessor applications. It is designed to drive two N-Channel MOSFETs in a synchronous-rectified buck topology. The HIP6004 integrates all of the control, output adjustment, monitoring and protection functions into a single package.

The output voltage of the converter is easily adjusted and precisely regulated. The HIP6004 includes a 5-input digital-to-analog converter (DAC) that adjusts the output voltage from 2.1V_{DC} to 3.5V_{DC} in 0.1V increments and from 1.3V_{DC} to 2.1V_{DC} in 0.05V steps. The precision reference and voltage-mode regulator hold the selected output voltage to within ±1% over temperature and line voltage variations.

The HIP6004 provides simple, single feedback loop, voltage-mode control with fast transient response. It includes a 200kHz free-running triangle-wave oscillator that is adjustable from below 50kHz to over 1MHz. The error amplifier features a 15MHz gain-bandwidth product and 6V/μs slew rate which enables high converter bandwidth for fast transient performance. The resulting PWM duty ratio ranges from 0% to 100%.

The HIP6004 monitors the output voltage with a window comparator that tracks the DAC output and issues a Power Good signal when the output is within ±10%. The HIP6004 protects against over-current conditions by inhibiting PWM operation. Built-in over-voltage protection triggers an external SCR to crowbar the input supply. The HIP6004 monitors the current by using the r_{DS(ON)} of the upper MOSFET which eliminates the need for a current sensing resistor.

Ordering Information

PART NUMBER	TEMP. RANGE (°C)	PACKAGE	PKG. NO.
HIP6004CB	0 to 70	20 Ld SOIC	M20.3

This data sheet describes a pre-released product.

Features

- Drives Two N-Channel MOSFETs
- Operates from +5V or +12V Input
- Simple Single-Loop Control Design
 - Voltage-Mode PWM Control
- Fast Transient Response
 - High-Bandwidth Error Amplifier
 - Full 0% to 100% Duty Ratio
- Excellent Output Voltage Regulation
 - ±1% Over Line Voltage and Temperature
- 5-Bit Digital-to-Analog Output Voltage Selection
 - Wide Range 1.3V_{DC} to 3.5V_{DC}
 - 0.1V Binary Steps 2.1V_{DC} to 3.5V_{DC}
 - 0.05V Binary Step 1.3V_{DC} to 2.1V_{DC}
- Power-Good Output Voltage Monitor
- Over-Voltage and Over-Current Fault Monitors
 - Does Not Require Extra Current Sensing Element, Uses MOSFETs r_{DS(ON)}
- Small Converter Size
 - Constant Frequency Operation
 - 200kHz Free-Running Oscillator Programmable from 50kHz to over 1MHz

Applications

- Power Supply for Pentium®, Pentium Pro, PowerPC™ and Alpha™ Microprocessors
- High-Power 5V to 3.xV DC-DC Regulators
- Low-Voltage Distributed Power Supplies

Pinout

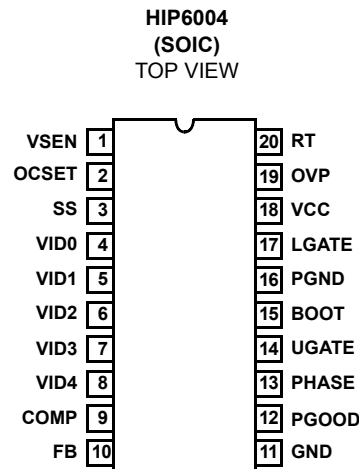

Typical Application

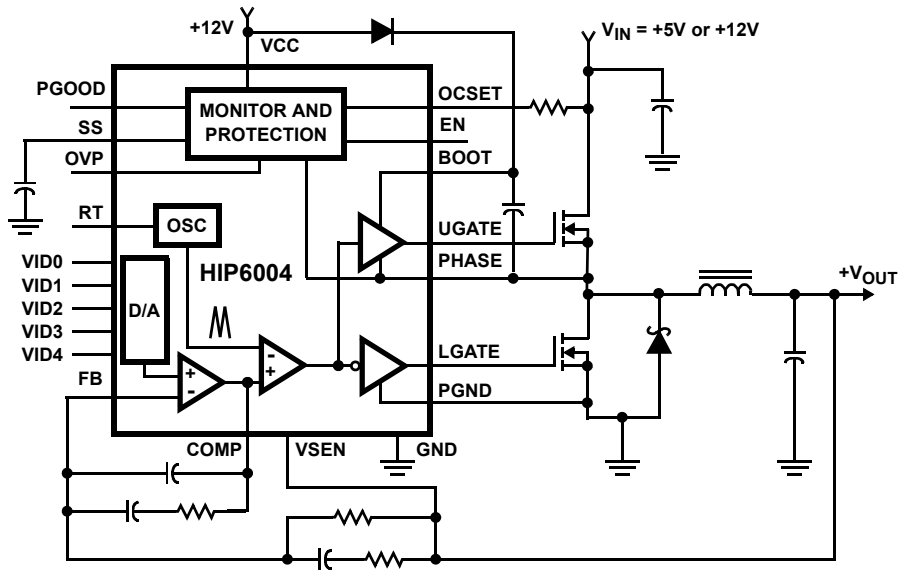

Block Diagram

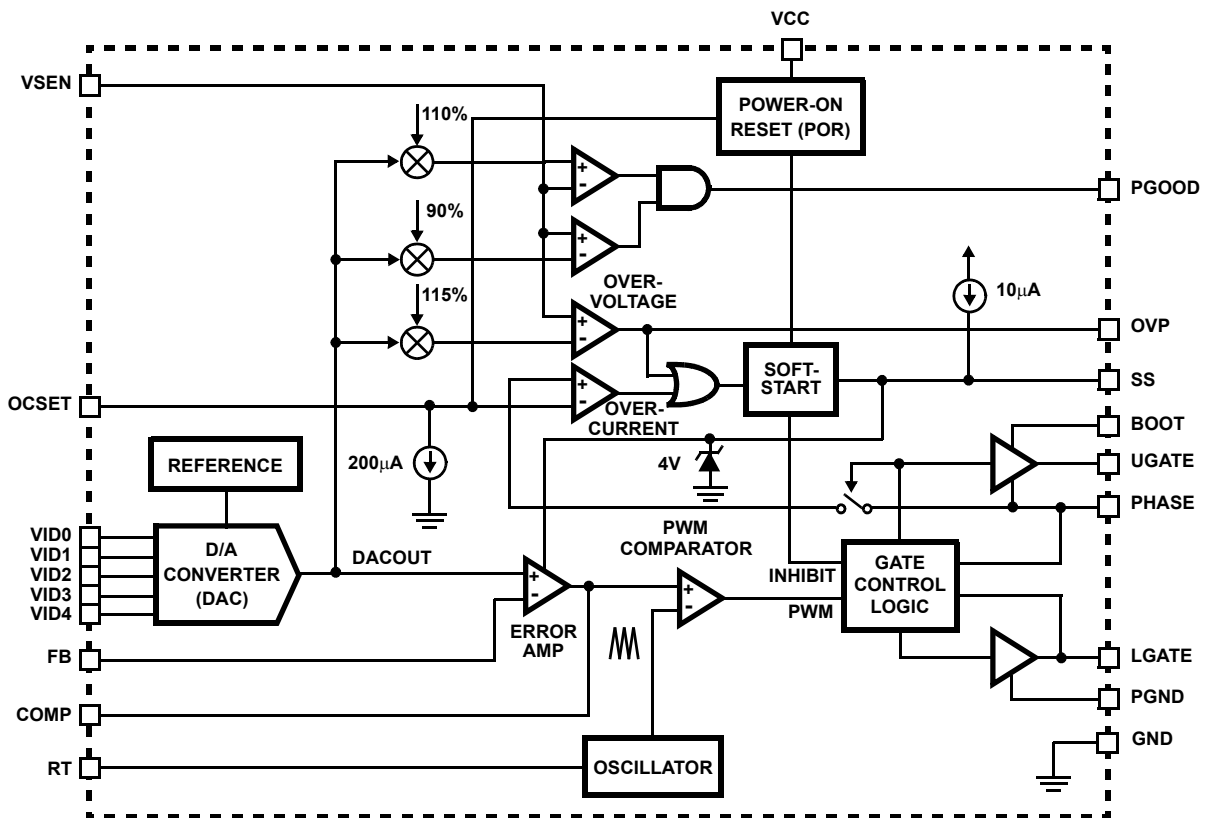

Absolute Maximum Ratings

Supply Voltage, V_{CC}	+15V
Boot Voltage, $V_{BOOT} - V_{PHASE}$	+15V
Input, Output or I/O Voltage	GND -0.3V to VCC +0.3V
ESD Classification	Class 2

Operating Conditions

Supply Voltage, V_{CC}	+12V \pm 10%
Ambient Temperature Range	0°C to 70°C
Junction Temperature Range	0°C to 125°C

Thermal Information

Thermal Resistance (Typical, Note 1)	θ_{JA} (°C/W)
SOIC Package	118
Maximum Junction Temperature (Plastic Package)	150°C
Maximum Storage Temperature Range	-65°C to 150°C
Maximum Lead Temperature (Soldering 10s)	300°C (SOIC - Lead Tips Only)

CAUTION: Stresses above those listed in "Absolute Maximum Ratings" may cause permanent damage to the device. This is a stress only rating and operation of the device at these or any other conditions above those indicated in the operational sections of this specification is not implied.

NOTE:

- θ_{JA} is measured with the component mounted on a low effective thermal conductivity test board in free air. See Tech Brief 379 for details.

Electrical Specifications Recommended Operating Conditions, Unless Otherwise Noted

PARAMETER	SYMBOL	TEST CONDITIONS	MIN	TYP	MAX	UNITS
VCC SUPPLY CURRENT						
Nominal Supply	I_{CC}	UGATE and LGATE Open	-	5	-	mA
POWER-ON RESET						
Rising VCC Threshold		$V_{OCSET} = 4.5V$	-	-	10.4	V
Falling VCC Threshold		$V_{OCSET} = 4.5V$	8.2	-	-	V
Rising V_{OCSET} Threshold			-	1.26	-	V
OSCILLATOR						
Free Running Frequency		RT = OPEN	185	200	215	kHz
Total Variation		6k Ω < RT to GND < 200k Ω	-15	-	+15	%
Ramp Amplitude	ΔV_{OSC}	RT = Open	-	1.9	-	V _{P-P}
REFERENCE AND DAC						
DACOUT Voltage Accuracy			-1.0	-	+1.0	%
ERROR AMPLIFIER						
DC Gain			-	88	-	dB
Gain-Bandwidth Product	GBW		-	15	-	MHz
Slew Rate	SR	COMP = 10pF	-	6	-	V/ μ s
GATE DRIVERS						
Upper Gate Source	I_{UGATE}	$V_{BOOT} - V_{PHASE} = 12V, V_{UGATE} = 6V$	350	500	-	mA
Upper Gate Sink	R_{UGATE}	$I_{LGATE} = 0.3A$	-	5.5	10	Ω
Lower Gate Source	I_{LGATE}	VCC = 12V, $V_{LGATE} = 6V$	300	450	-	mA
Lower Gate Sink	R_{LGATE}	$I_{LGATE} = 0.3A$	-	3.5	6.5	Ω
PROTECTION						
Over-Voltage Trip ($V_{SEN}/DACOUT$)			-	115	120	%
OCSET Current Source	I_{OCSET}	$V_{OCSET} = 4.5V_{DC}$	170	200	230	μ A
OVP Sourcing Current	I_{OVP}	$V_{SEN} = 5.5V, V_{OVP} = 0V$	60	-	-	mA
Soft Start Current	I_{SS}		-	10	-	μ A
POWER GOOD						
Upper Threshold ($V_{SEN} / DACOUT$)		VSEN Rising	106	-	111	%
Lower Threshold ($V_{SEN} / DACOUT$)		VSEN Falling	89	-	94	%
Hysteresis ($V_{SEN} / DACOUT$)		Upper and Lower Threshold	-	2	-	%
PGOOD Voltage Low	V_{PGOOD}	$I_{PGOOD} = -5mA$	-	0.5	-	V

Typical Performance Curves

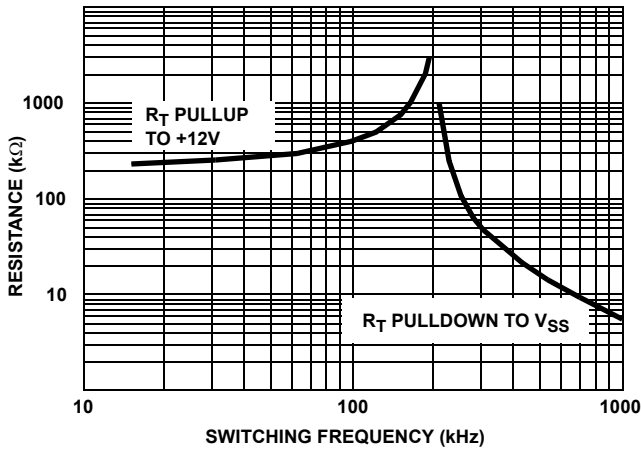

FIGURE 1. R_T RESISTANCE vs FREQUENCY

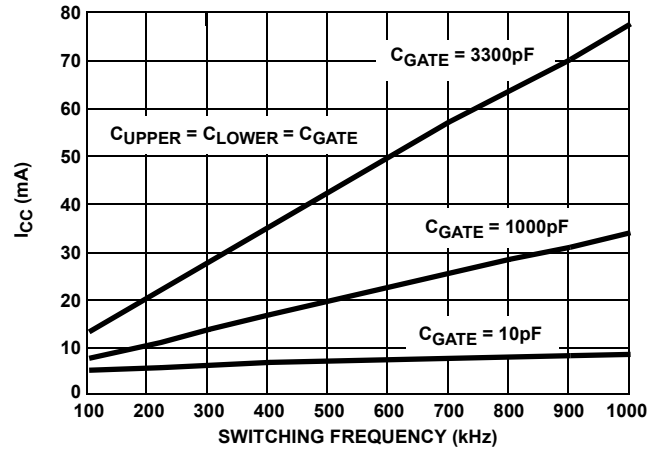
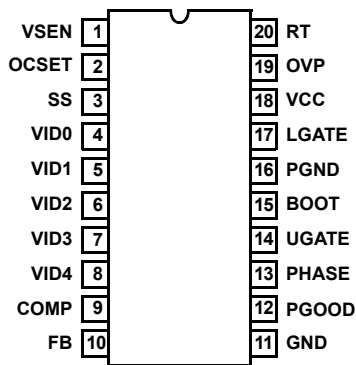

FIGURE 2. BIAS SUPPLY CURRENT vs FREQUENCY

Functional Pin Description



VSEN (Pin 1)

This pin is connected to the converters output voltage. The PGOOD and OVP comparator circuits use this signal to report output voltage status and for overvoltage protection.

OCSET (Pin 2)

Connect a resistor (R_{OCSET}) from this pin to the drain of the upper MOSFET. R_{OCSET} , an internal $200\mu A$ current source (I_{OCS}), and the upper MOSFET on-resistance ($r_{DS(ON)}$) set the converter over-current (OC) trip point according to the following equation:

$$I_{PEAK} = \frac{I_{OCS} \cdot R_{OCSET}}{r_{DS(ON)}}$$

An over-current trip cycles the soft-start function.

SS (Pin 3)

Connect a capacitor from this pin to ground. This capacitor, along with an internal $10\mu A$ current source, sets the soft-start interval of the converter.

VID0-4 (Pins 4-8)

VID0-4 are the input pins to the 5-bit DAC. The states of these five pins program the internal voltage reference (DACOUT). The level of DACOUT sets the converter output voltage. It also sets the PGOOD and OVP thresholds. Table 1 specifies DACOUT for the 32 combinations of DAC inputs.

COMP (Pin 9) and FB (Pin 10)

COMP and FB are the available external pins of the error amplifier. The FB pin is the inverting input of the error amplifier and the COMP pin is the error amplifier output. These pins are used to compensate the voltage-control feedback loop of the converter.

GND (Pin 11)

Signal ground for the IC. All voltage levels are measured with respect to this pin.

PGOOD (Pin 12)

PGOOD is an open collector output used to indicate the status of the converter output voltage. This pin is pulled low when the converter output is not within $\pm 10\%$ of the DACOUT reference voltage.

PHASE (Pin 13)

Connect the PHASE pin to the upper MOSFET source. This pin is used to monitor the voltage drop across the MOSFET for over-current protection. This pin also provides the return path for the upper gate drive.

UGATE (Pin 14)

Connect UGATE to the upper MOSFET gate. This pin provides the gate drive for the upper MOSFET.

BOOT (Pin 15)

This pin provides bias voltage to the upper MOSFET driver. A bootstrap circuit may be used to create a BOOT voltage suitable to drive a standard N-Channel MOSFET.

PGND (Pin 16)

This is the power ground connection. Tie the lower MOSFET source to this pin.

LGATE (Pin 17)

Connect LGATE to the lower MOSFET gate. This pin provides the gate drive for the lower MOSFET.

VCC (Pin 18)

Provide a 12V bias supply for the chip to this pin.

OVP (Pin 19)

The OVP pin can be used to drive an external SCR in the event of an overvoltage condition.

RT (Pin 20)

This pin provides oscillator switching frequency adjustment. By placing a resistor (R_T) from this pin to GND, the nominal 200kHz switching frequency is increased according to the following equation:

$$F_s \approx 200\text{kHz} + \frac{5 \cdot 10^6}{R_T(\text{k}\Omega)} \quad (R_T \text{ to GND})$$

Conversely, connecting a pull-up resistor (R_T) from this pin to VCC reduces the switching frequency according to the following equation:

$$F_s \approx 200\text{kHz} - \frac{4 \cdot 10^7}{R_T(\text{k}\Omega)} \quad (R_T \text{ to 12V})$$

Functional Description

Initialization

The HIP6004 automatically initializes upon receipt of power. Special sequencing of the input supplies is not necessary. The Power-On Reset (POR) function continually monitors the input supply voltages. The POR monitors the bias voltage at the VCC pin and the input voltage (V_{IN}) on the OCSET pin. The level on OCSET is equal to V_{IN} less a fixed voltage drop (see over-current protection). The POR function initiates soft start operation after both input supply voltages exceed their POR thresholds. For operation with a single +12V power source, V_{IN} and V_{CC} are equivalent and the +12V power source must exceed the rising V_{CC} threshold before POR initiates operation.

Soft Start

The POR function initiates the soft start sequence. An internal 10 μ A current source charges an external capacitor (C_{SS}) on the SS pin to 4V. Soft start clamps the error amplifier output (COMP pin) and reference input (+ terminal of error amp) to the SS pin voltage. Figure 3 shows the soft start interval with $C_{SS} = 0.1\mu\text{F}$. Initially the clamp on the error amplifier (COMP pin) controls the converter's output voltage. At t_1 in Figure 3, the SS voltage reaches the valley of the oscillator's triangle wave. The oscillator's triangular waveform is compared to the ramping error amplifier voltage. This generates PHASE pulses of increasing width that

charge the output capacitor(s). This interval of increasing pulse width continues to t_2 . With sufficient output voltage, the clamp on the reference input controls the output voltage. This is the interval between t_2 and t_3 in Figure 3. At t_3 the SS voltage exceeds the DACOUT voltage and the output voltage is in regulation. This method provides a rapid and controlled output voltage rise. The PGOOD signal toggles 'high' when the output voltage (V_{SEN} pin) is within $\pm 5\%$ of DACOUT. The 2% hysteresis built into the power good comparators prevents PGOOD oscillation due to nominal output voltage ripple.

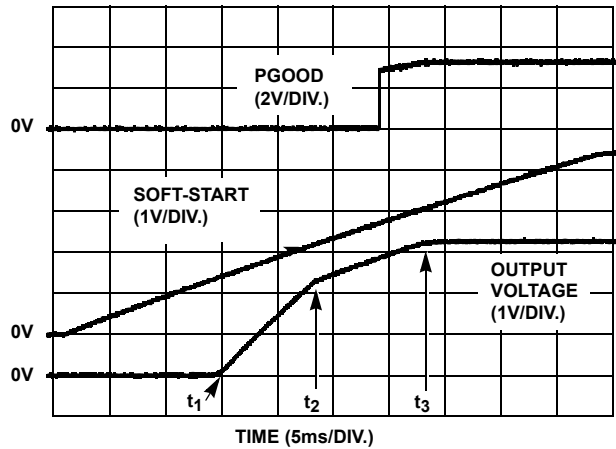

FIGURE 3. SOFT START INTERVAL

Over-Current Protection

The over-current function protects the converter from a shorted output by using the upper MOSFETs on-resistance, $r_{DS(ON)}$ to monitor the current. This method enhances the converter's efficiency and reduces cost by eliminating a current sensing resistor.

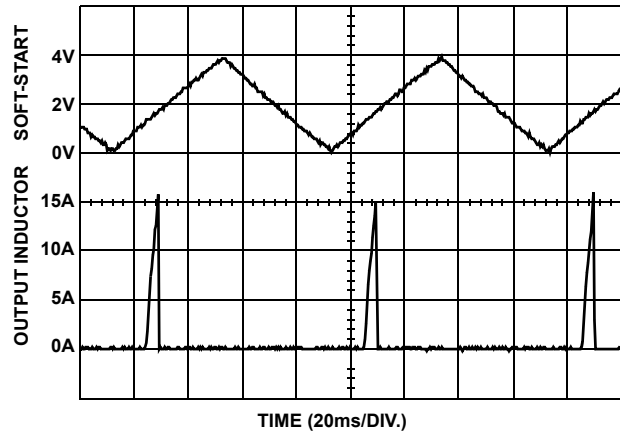

FIGURE 4. OVER-CURRENT OPERATION

The over-current function cycles the soft-start function in a hiccup mode to provide fault protection. A resistor (R_{OCSET}) programs the over-current trip level. An internal 200 μ A current sink develops a voltage across R_{OCSET} that is referenced to V_{IN} . When the voltage across the upper MOSFET (also referenced to V_{IN}) exceeds the voltage across R_{OCSET} , the over-current function

initiates a soft-start sequence. The soft-start function discharges C_{SS} with a 10µA current sink and inhibits PWM operation. The soft-start function recharges C_{SS}, and PWM operation resumes with the error amplifier clamped to the SS voltage. Should an overload occur while recharging C_{SS}, the soft start function inhibits PWM operation while fully charging C_{SS} to 4V to complete its cycle. Figure 4 shows this operation with an overload condition. Note that the inductor current increases to over 15A during the C_{SS} charging interval and causes an over-current trip. The converter dissipates very little power with this method. The measured input power for the conditions of Figure 4 is 2.5W.

The over-current function will trip at a peak inductor current (I_{PEAK}) determined by:

$$I_{PEAK} = \frac{I_{OCSET} \cdot R_{OCSET}}{r_{DS(ON)}}$$

where I_{OCSET} is the internal OCSET current source (200µA typical). The OC trip point varies mainly due to the MOSFETs r_{DS(ON)} variations. To avoid over-current tripping in the normal operating load range, find the R_{OCSET} resistor from the equation above with:

1. The maximum r_{DS(ON)} at the highest junction temperature.
2. The minimum I_{OCSET} from the specification table.
3. Determine I_{PEAK} for I_{PEAK} > I_{OUT(MAX)} + (ΔI)/2, where ΔI is the output inductor ripple current.

For an equation for the ripple current see the section under component guidelines titled 'Output Inductor Selection'.

TABLE 1. OUTPUT VOLTAGE PROGRAM

PIN NAME					NOMINAL OUTPUT VOLTAGE DACOUT	PIN NAME					NOMINAL OUTPUT VOLTAGE DACOUT
VID4	VID3	VID2	VID1	VID0		VID4	VID3	VID2	VID1	VID0	
0	1	1	1	1	1.30	1	1	1	1	1	2.0
0	1	1	1	0	1.35	1	1	1	1	0	2.1
0	1	1	0	1	1.40	1	1	1	0	1	2.2
0	1	1	0	0	1.45	1	1	1	0	0	2.3
0	1	0	1	1	1.50	1	1	0	1	1	2.4
0	1	0	1	0	1.55	1	1	0	1	0	2.5
0	1	0	0	1	1.60	1	1	0	0	1	2.6
0	1	0	0	0	1.65	1	1	0	0	0	2.7
0	0	1	1	1	1.70	1	0	1	1	1	2.8
0	0	1	1	0	1.75	1	0	1	1	0	2.9
0	0	1	0	1	1.80	1	0	1	0	1	3.0
0	0	1	0	0	1.85	1	0	1	0	0	3.1
0	0	0	1	1	1.90	1	0	0	1	1	3.2
0	0	0	1	0	1.95	1	0	0	1	0	3.3
0	0	0	0	1	2.00	1	0	0	0	1	3.4
0	0	0	0	0	2.05	1	0	0	0	0	3.5

NOTE: 0 = connected to GND or V_{SS}, 1 = OPEN.

A small ceramic capacitor should be placed in parallel with R_{OCSET} to smooth the voltage across R_{OCSET} in the presence of switching noise on the input voltage.

Output Voltage Program

The output voltage of a HIP6004 converter is programmed to discrete levels between 1.3V_{DC} and 3.5V_{DC}. The voltage identification (VID) pins program an internal voltage reference (DACOUT) with a 5-bit digital-to-analog converter (DAC). The level of DACOUT also sets the PGOOD and OVP thresholds. Table 1 specifies the DACOUT voltage for the 32 combinations of open or short connections on the VID pins. The output voltage should not be adjusted while the converter

is delivering power. Remove input power before changing the output voltage. Adjusting the output voltage during operation could toggle the PGOOD signal and exercise the overvoltage protection.

The DAC function is a precision non-inverting summation amplifier shown in Figure 5. The resistor values shown are only approximations of the actual precision values used. Grounding any combination of the VID pins increases the DACOUT voltage. The 'open' circuit voltage on the VID pins is the band gap reference voltage, 1.26V.

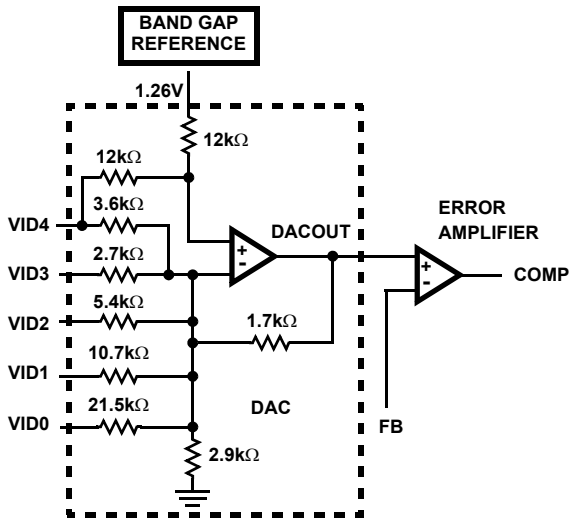

FIGURE 5. DAC FUNCTION SCHEMATIC

Application Guidelines

Layout Considerations

As in any high frequency switching converter, layout is very important. Switching current from one power device to another can generate voltage transients across the impedances of the interconnecting bond wires and circuit traces. These interconnecting impedances should be minimized by using wide, short printed circuit traces. The critical components should be located as close together as possible, using ground plane construction or single point grounding.

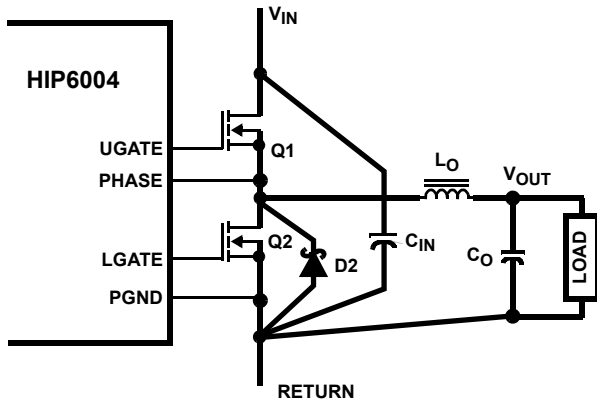

FIGURE 6. PRINTED CIRCUIT BOARD POWER AND GROUND PLANES OR ISLANDS

Figure 6 shows the critical power components of the converter. To minimize the voltage overshoot the interconnecting wires indicated by heavy lines should be part of ground or power plane in a printed circuit board. The components shown in Figure 6 should be located as close together as possible. Please note that the capacitors C_{IN} and C_O each represent numerous physical capacitors. Locate the HIP6004 within 3 inches of the MOSFETs, Q1 and Q2. The circuit traces for the MOSFETs' gate and source connections from the HIP6004 must be sized to handle up to 1A peak current.

Figure 7 shows the circuit traces that require additional layout consideration. Use single point and ground plane construction for the circuits shown. Minimize any leakage current paths on the SS PIN and locate the capacitor, C_{SS} close to the SS pin because the internal current source is only $10\mu A$. Provide local V_{CC} decoupling between VCC and GND pins. Locate the capacitor, C_{BOOT} as close as practical to the BOOT and PHASE pins.

Feedback Compensation

Figure 8 highlights the voltage-mode control loop for a synchronous-rectified buck converter. The output voltage (V_{OUT}) is regulated to the Reference voltage level. The error amplifier (Error Amp) output ($V_{E/A}$) is compared with the oscillator (OSC) triangular wave to provide a pulse-width modulated (PWM) wave with an amplitude of V_{IN} at the PHASE node. The PWM wave is smoothed by the output filter (L_O and C_O).

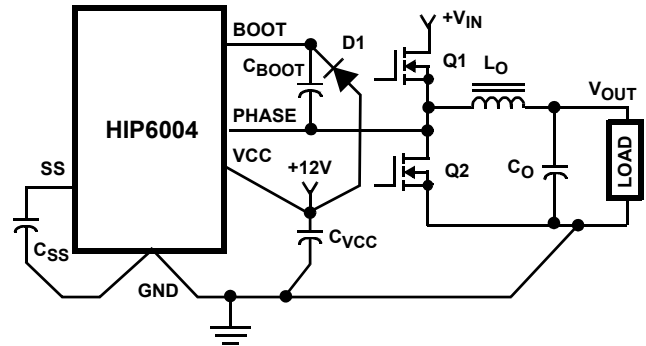

FIGURE 7. PRINTED CIRCUIT BOARD SMALL SIGNAL LAYOUT GUIDELINES

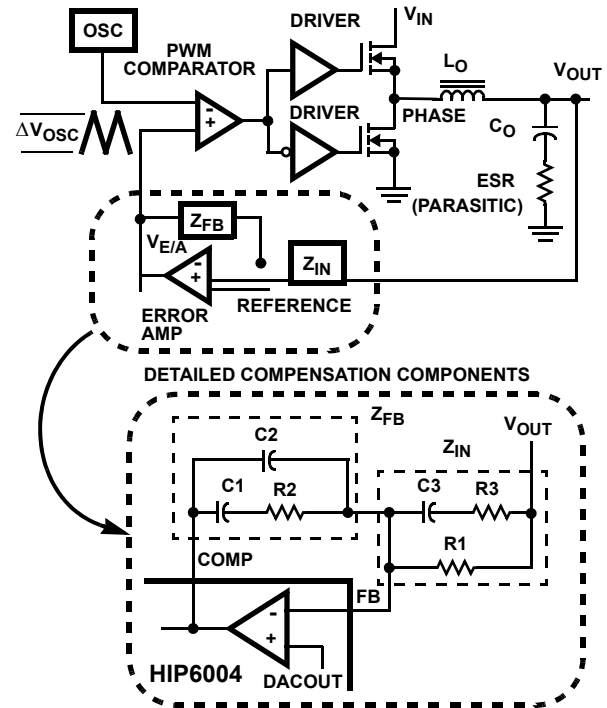

FIGURE 8. VOLTAGE-MODE BUCK CONVERTER COMPENSATION DESIGN

The modulator transfer function is the small-signal transfer function of $V_{OUT}/V_{E/A}$. This function is dominated by a DC Gain and the output filter (L_O and C_O), with a double pole break frequency at F_{LC} and a zero at F_{ESR} . The DC Gain of the modulator is simply the input voltage (V_{IN}) divided by the peak-to-peak oscillator voltage ΔV_{OSC} .

Modulator Break Frequency Equations

$$F_{LC} = \frac{1}{2\pi \cdot \sqrt{L_O \cdot C_O}} \quad F_{ESR} = \frac{1}{2\pi \cdot ESR \cdot C_O}$$

The compensation network consists of the error amplifier (internal to the HIP6004) and the impedance networks Z_{IN} and Z_{FB} . The goal of the compensation network is to provide a closed loop transfer function with the highest 0dB crossing frequency (f_{0dB}) and adequate phase margin. Phase margin is the difference between the closed loop phase at f_{0dB} and 180 degrees. The equations below relate the compensation network's poles, zeros and gain to the components (R_1 , R_2 , R_3 , C_1 , C_2 , and C_3) in Figure 8. Use these guidelines for locating the poles and zeros of the compensation network:

1. Pick Gain (R_2/R_1) for desired converter bandwidth
2. Place 1ST Zero Below Filter's Double Pole ($\sim 75\% F_{LC}$)
3. Place 2ND Zero at Filter's Double Pole
4. Place 1ST Pole at the ESR Zero
5. Place 2ND Pole at Half the Switching Frequency
6. Check Gain against Error Amplifier's Open-Loop Gain
7. Estimate Phase Margin - Repeat if Necessary

Compensation Break Frequency Equations

$$F_{Z1} = \frac{1}{2\pi \cdot R_2 \cdot C_1} \quad F_{P1} = \frac{1}{2\pi \cdot R_2 \cdot \left(\frac{C_1 \cdot C_2}{C_1 + C_2}\right)}$$

$$F_{Z2} = 2\pi \cdot (R_1 + R_3) \cdot C_3 \quad F_{P2} = \frac{1}{2\pi \cdot R_3 \cdot C_3}$$

Figure 9 shows an asymptotic plot of the DC-DC converter's gain vs. frequency. The actual Modulator Gain has a high gain peak due to the high Q factor of the output filter and is not shown in Figure 9. Using the above guidelines should give a Compensation Gain similar to the curve plotted. The open loop error amplifier gain bounds the compensation gain. Check the compensation gain at F_{P2} with the capabilities of the error amplifier. The Closed Loop Gain is constructed on the log-log graph of Figure 9 by adding the Modulator Gain (in dB) to the Compensation Gain (in dB). This is equivalent to multiplying the modulator transfer function to the compensation transfer function and plotting the gain.

The compensation gain uses external impedance networks Z_{FB} and Z_{IN} to provide a stable, high bandwidth (BW) overall loop. A stable control loop has a gain crossing with -20dB/decade slope and a phase margin greater than 45 degrees. Include worst case component variations when determining phase margin.

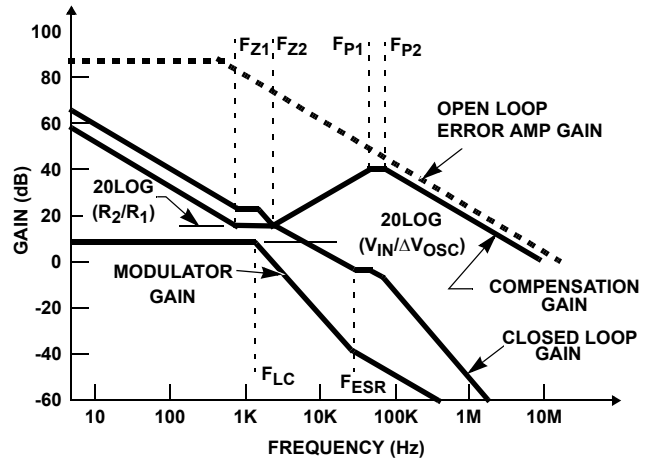

FIGURE 9. ASYMPTOTIC BODE PLOT OF CONVERTER GAIN

Component Selection Guidelines

Output Capacitor Selection

An output capacitor is required to filter the output and supply the load transient current. The filtering requirements are a function of the switching frequency and the ripple current. The load transient requirements are a function of the slew rate (di/dt) and the magnitude of the transient load current. These requirements are generally met with a mix of capacitors and careful layout.

Modern microprocessors produce transient load rates above 1A/ns. High frequency capacitors initially supply the transient and slow the current load rate seen by the bulk capacitors. The bulk filter capacitor values are generally determined by the ESR (effective series resistance) and voltage rating requirements rather than actual capacitance requirements.

High frequency decoupling capacitors should be placed as close to the power pins of the load as physically possible. Be careful not to add inductance in the circuit board wiring that could cancel the usefulness of these low inductance components. Consult with the manufacturer of the load on specific decoupling requirements. For example, Intel recommends that the high frequency decoupling for the Pentium Pro be composed of at least forty (40) 1 μ F ceramic capacitors in the 1206 surface-mount package.

Use only specialized low-ESR capacitors intended for switching-regulator applications for the bulk capacitors. The bulk capacitor's ESR will determine the output ripple voltage and the initial voltage drop after a high slew-rate transient. An aluminum electrolytic capacitor's ESR value is related to the case size with lower ESR available in larger case sizes. However, the equivalent series inductance (ESL) of these capacitors increases with case size and can reduce the usefulness of the capacitor to high slew-rate transient loading. Unfortunately, ESL is not a specified parameter. Work with your capacitor supplier and measure the capacitor's impedance with frequency to select a suitable component. In most cases, multiple electrolytic

capacitors of small case size perform better than a single large case capacitor.

Output Inductor Selection

The output inductor is selected to meet the output voltage ripple requirements and minimize the converter's response time to the load transient. The inductor value determines the converter's ripple current and the ripple voltage is a function of the ripple current. The ripple voltage and current are approximated by the following equations:

$$\Delta I = \frac{V_{IN} - V_{OUT}}{F_s \times L} \cdot \frac{V_{OUT}}{V_{IN}} \quad \Delta V_{OUT} = \Delta I \times ESR$$

Increasing the value of inductance reduces the ripple current and voltage. However, the large inductance values reduce the converter's response time to a load transient.

One of the parameters limiting the converter's response to a load transient is the time required to change the inductor current. Given a sufficiently fast control loop design, the HIP6004 will provide either 0% or 100% duty cycle in response to a load transient. The response time is the time required to slew the inductor current from an initial current value to the transient current level. During this interval the difference between the inductor current and the transient current level must be supplied by the output capacitor. Minimizing the response time can minimize the output capacitance required.

The response time to a transient is different for the application of load and the removal of load. The following equations give the approximate response time interval for application and removal of a transient load:

$$t_{RISE} = \frac{L \times I_{TRAN}}{V_{IN} - V_{OUT}} \quad t_{FALL} = \frac{L \times I_{TRAN}}{V_{OUT}}$$

where: I_{TRAN} is the transient load current step, t_{RISE} is the response time to the application of load, and t_{FALL} is the response time to the removal of load. With a +5V input source, the worst case response time can be either at the application or removal of load and dependent upon the DACOUT setting. Be sure to check both of these equations at the minimum and maximum output levels for the worst case response time. With a +12V input, and output voltage level equal to DACOUT, t_{FALL} is the longest response time.

Input Capacitor Selection

Use a mix of input bypass capacitors to control the voltage overshoot across the MOSFETs. Use small ceramic capacitors for high frequency decoupling and bulk capacitors to supply the current needed each time Q1 turns on. Place the small ceramic capacitors physically close to the MOSFETs and between the drain of Q1 and the source of Q2.

The important parameters for the bulk input capacitor are the voltage rating and the RMS current rating. For reliable operation, select the bulk capacitor with voltage and current ratings above the maximum input voltage and largest RMS current required by the circuit. The capacitor voltage rating

should be at least 1.25 times greater than the maximum input voltage and a voltage rating of 1.5 times is a conservative guideline. The RMS current rating requirement for the input capacitor of a buck regulator is approximately 1/2 the DC load current.

For a through hole design, several electrolytic capacitors (Panasonic HFQ series or Nichicon PL series or Sanyo MV-GX or equivalent) may be needed. For surface mount designs, solid tantalum capacitors can be used, but caution must be exercised with regard to the capacitor surge current rating. These capacitors must be capable of handling the surge-current at power-up. The TPS series available from AVX, and the 593D series from Sprague are both surge current tested.

MOSFET Selection/Considerations

The HIP6004 requires 2 N-Channel power MOSFETs. These should be selected based upon $r_{DS(ON)}$, gate supply requirements, and thermal management requirements.

In high-current applications, the MOSFET power dissipation, package selection and heatsink are the dominant design factors. The power dissipation includes two loss components; conduction loss and switching loss. The conduction losses are the largest component of power dissipation for both the upper and the lower MOSFETs. These losses are distributed between the two MOSFETs according to duty factor (see the equations below). Only the upper MOSFET has switching losses, since the Schottky rectifier clamps the switching node before the synchronous rectifier turns on. These equations assume linear voltage-current transitions and do not adequately model power loss due the reverse-recovery of the lower MOSFETs body diode. The gate-charge losses are dissipated by the HIP6004 and don't heat the MOSFETs. However, large gate-charge increases the switching interval, t_{SW} which increases the upper MOSFET switching losses. Ensure that both MOSFETs are within their maximum junction temperature at high ambient temperature by calculating the temperature rise according to package thermal-resistance specifications. A separate heatsink may be necessary depending upon MOSFET power, package type, ambient temperature and air flow.

$$P_{UPPER} = I_o^2 \times r_{DS(ON)} \times D + \frac{1}{2} I_o \times V_{IN} \times t_{SW} \times F_s$$

$$P_{LOWER} = I_o^2 \times r_{DS(ON)} \times (1 - D)$$

Where: D is the duty cycle = V_{OUT} / V_{IN} ,
 t_{SW} is the switching interval, and
 F_s is the switching frequency.

Standard-gate MOSFETs are normally recommended for use with the HIP6004. However, logic-level gate MOSFETs can be used under special circumstances. The input voltage, upper gate drive level, and the MOSFETs absolute gate-to-source voltage rating determine whether logic-level MOSFETs are appropriate.

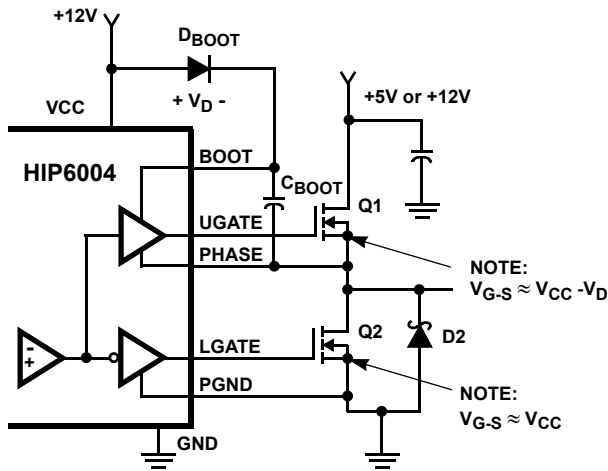

FIGURE 10. UPPER GATE DRIVE - BOOTSTRAP OPTION

Figure 10 shows the upper gate drive (BOOT pin) supplied by a bootstrap circuit from V_{CC} . The boot capacitor, C_{BOOT} develops a floating supply voltage referenced to the PHASE pin. This supply is refreshed each cycle to a voltage of V_{CC} less the boot diode drop (V_D) when the lower MOSFET, Q2 turns on. Logic-level MOSFETs can only be used if the MOSFETs absolute gate-to-source voltage rating exceeds the maximum voltage applied to V_{CC} .

Figure 11 shows the upper gate drive supplied by a direct connection to V_{CC} . This option should only be used in converter systems where the main input voltage is $+5V_{DC}$ or less. The peak upper gate-to-source voltage is approximately V_{CC} less the input supply. For $+5V$ main power and $+12V_{DC}$ for the bias, the gate-to-source voltage of Q1 is $7V$. A logic-level MOSFET is a good choice for Q1 and a logic-level MOSFET can be used for Q2 if its absolute gate-to-source voltage rating exceeds the maximum voltage applied to V_{CC} .

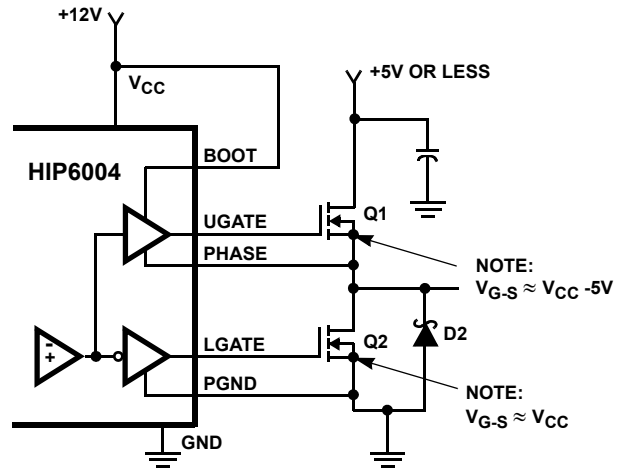

FIGURE 11. UPPER GATE DRIVE - DIRECT V_{CC} DRIVE OPTION

Schottky Selection

Rectifier D2 is a clamp that catches the negative inductor swing during the dead time between turning off the lower MOSFET and turning on the upper MOSFET. The diode must be a Schottky type to prevent the lossy parasitic MOSFET body diode from conducting. It is acceptable to omit the diode and let the body diode of the lower MOSFET clamp the negative inductor swing, but efficiency will drop one or two percent as a result. The diode's rated reverse breakdown voltage must be greater than the maximum input voltage.

HIP6004 DC-DC Converter Application Circuit

Figure 12 shows an application circuit of a DC-DC Converter for an Intel Pentium Pro microprocessor. Detailed information

on the circuit, including a complete Bill-of-Materials and circuit board description, can be found in Application Note AN9672.

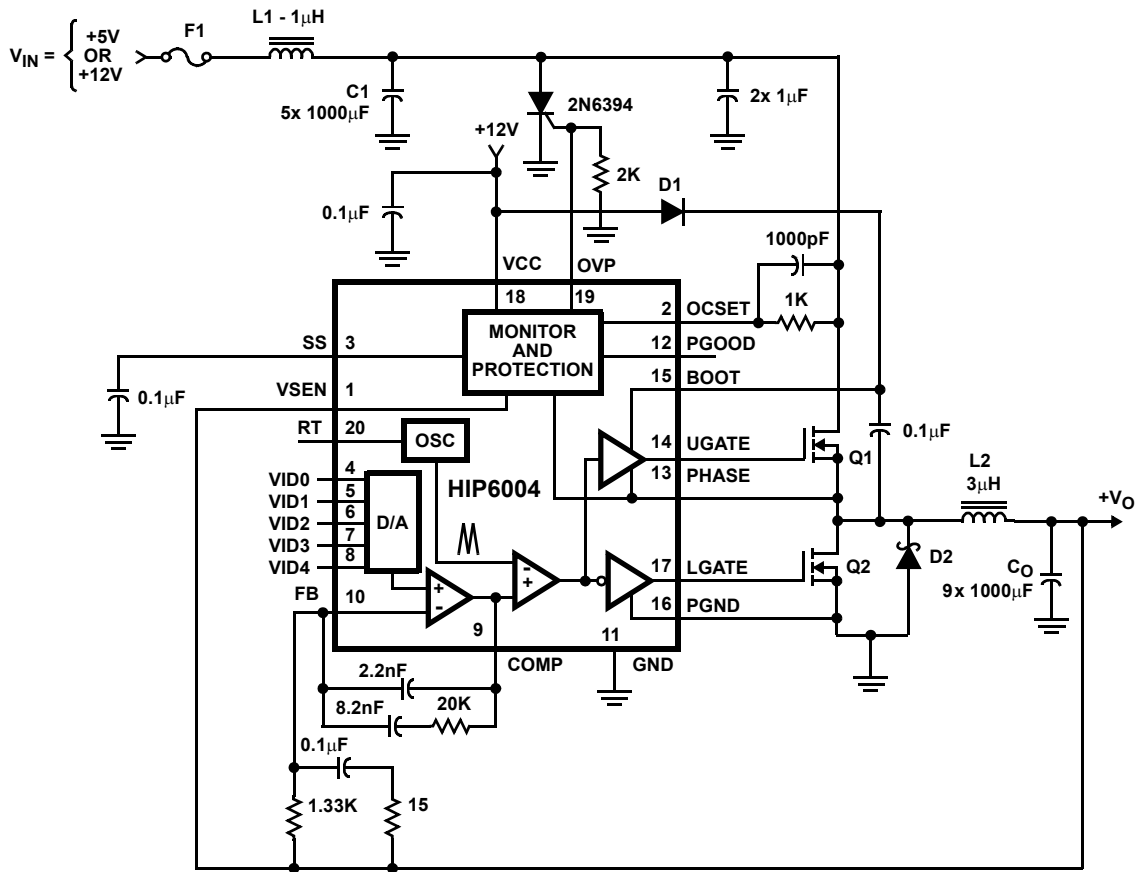

Component Selection Notes;

- C₀ - 9 Each 1000µF 6.3W VDC, Sanyo MV-GX or Equivalent
- C₁ - 5 Each 330µF 25W VDC, Sanyo MV-GX or Equivalent
- L₂ - Core: Micrometals T50-52B; Each Winding: 10 Turns of 16AWG
- L₁ - Core: Micrometals T50-52; Winding: 5 Turns of 18AWG
- D₁ - 1N4148 or Equivalent
- D₂ - 3A, 40V Schottky, Motorola MBR340 or Equivalent
- Q₁, Q₂ - Intersil MOSFET; RFP70N03

FIGURE 12. PENTIUM PRO DC-DC CONVERTER

Small Outline Plastic Packages (SOIC)

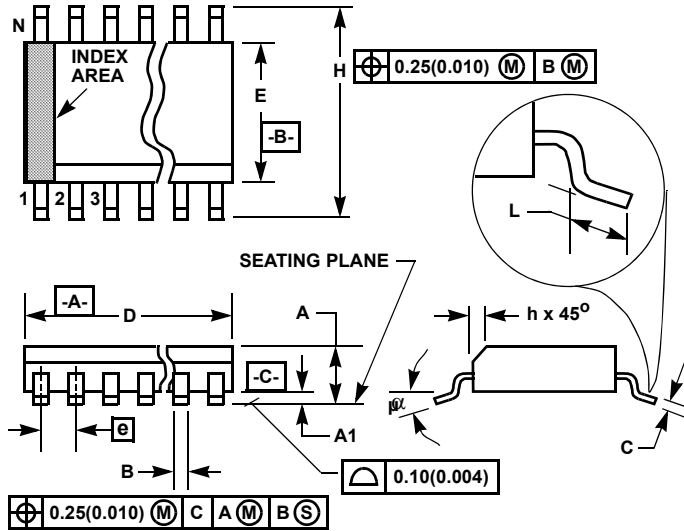

**M20.3 (JEDEC MS-013-AC ISSUE C)
20 LEAD WIDE BODY SMALL OUTLINE PLASTIC PACKAGE**

SYMBOL	INCHES		MILLIMETERS		NOTES
	MIN	MAX	MIN	MAX	
A	0.0926	0.1043	2.35	2.65	-
A1	0.0040	0.0118	0.10	0.30	-
B	0.013	0.0200	0.33	0.51	9
C	0.0091	0.0125	0.23	0.32	-
D	0.4961	0.5118	12.60	13.00	3
E	0.2914	0.2992	7.40	7.60	4
e	0.050 BSC		1.27 BSC		-
H	0.394	0.419	10.00	10.65	-
h	0.010	0.029	0.25	0.75	5
L	0.016	0.050	0.40	1.27	6
N	20		20		7
α	0°	8°	0°	8°	-

NOTES:

1. Symbols are defined in the "MO Series Symbol List" in Section 2.2 of Publication Number 95.
2. Dimensioning and tolerancing per ANSI Y14.5M-1982.
3. Dimension "D" does not include mold flash, protrusions or gate burrs. Mold flash, protrusion and gate burrs shall not exceed 0.15mm (0.006 inch) per side.
4. Dimension "E" does not include interlead flash or protrusions. Interlead flash and protrusions shall not exceed 0.25mm (0.010 inch) per side.
5. The chamfer on the body is optional. If it is not present, a visual index feature must be located within the crosshatched area.
6. "L" is the length of terminal for soldering to a substrate.
7. "N" is the number of terminal positions.
8. Terminal numbers are shown for reference only.
9. The lead width "B", as measured 0.36mm (0.014 inch) or greater above the seating plane, shall not exceed a maximum value of 0.61mm (0.024 inch)
10. Controlling dimension: MILLIMETER. Converted inch dimensions are not necessarily exact.

Rev. 0 12/93

© Copyright Intersil Americas LLC 2000. All Rights Reserved.

All trademarks and registered trademarks are the property of their respective owners.

For additional products, see www.intersil.com/en/products.html

Intersil products are manufactured, assembled and tested utilizing ISO9001 quality systems as noted in the quality certifications found at www.intersil.com/en/support/qualandreliability.html

Intersil products are sold by description only. Intersil may modify the circuit design and/or specifications of products at any time without notice, provided that such modification does not, in Intersil's sole judgment, affect the form, fit or function of the product. Accordingly, the reader is cautioned to verify that datasheets are current before placing orders. Information furnished by Intersil is believed to be accurate and reliable. However, no responsibility is assumed by Intersil or its subsidiaries for its use; nor for any infringements of patents or other rights of third parties which may result from its use. No license is granted by implication or otherwise under any patent or patent rights of Intersil or its subsidiaries.

For information regarding Intersil Corporation and its products, see www.intersil.com