

### General Description

The ICS843156 is a high frequency clock generator. The ICS843156 uses an external 25MHz crystal to synthesize 156.25MHz clock. The ICS843156 has excellent cycle-to-cycle and RMS period jitter performance.

The ICS843156 operates at full 3.3V and 2.5V, or mixed 3.3V/2.5V operating supplies and is available in a fully RoHS compliant 32-lead VFQFN package.

### Features

- Ten differential LVPECL outputs of 156.25MHz
- Crystal oscillator interface designed for 18pF, 25MHz parallel resonant crystal
- Cycle-to-cycle jitter: 40ps (maximum)
- RMS phase jitter at 156.25MHz (1.875MHz - 20MHz): 0.39ps (typical)
- Output Duty Cycle: 45% – 55%
- Full 3.3V and 2.5V, or mixed 3.3V/2.5V supply modes
- 0°C to 70°C ambient operating temperature
- Available in lead-free (RoHS 6) package
- For drop-in replacement part use 843156

### Output Frequency Table

Crystal Frequency (MHz)	Feedback Divider	VCO Frequency (MHz)	Output Divider	Output Frequency (MHz)
25	25	625	÷4	156.25

### Pin Assignment

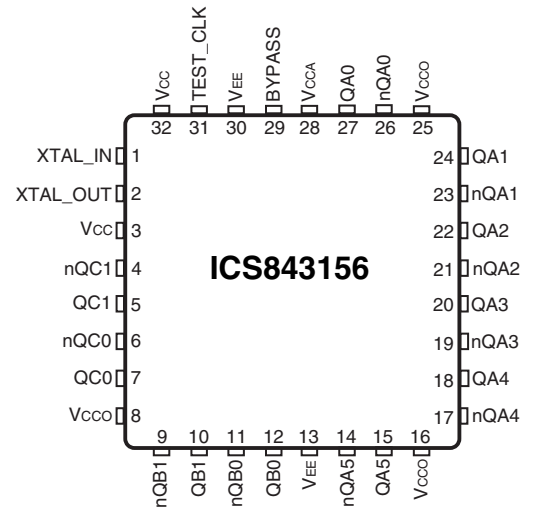

### Block Diagram

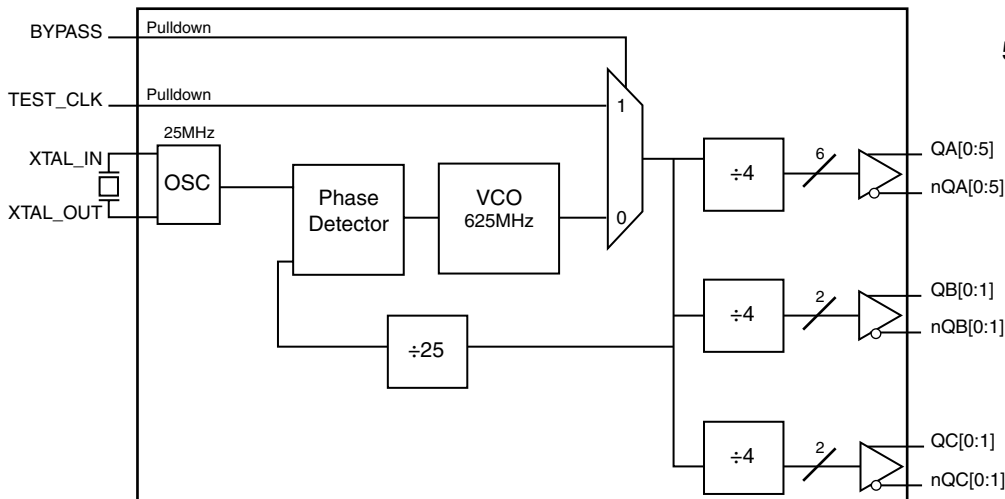

**32-Lead VFQFN**  
**5mm x 5mm x 0.925mm package body**  
**3.15mm x 3.15mm EPad**  
**K Package**  
**Top View**

### Table 1. Pin Descriptions

Number	Name	Type		Description
1, 2	XTAL_IN XTAL_OUT	Input		Crystal oscillator interface. XTAL_IN is the input, XTAL_OUT is the output.
3, 32	V <sub>CC</sub>	Power		Core supply pins.
4, 5	nQC1, QC1	Output		Differential output pair. LVPECL interface levels.
6, 7	nQC0, QC0	Output		Differential output pair. LVPECL interface levels.
8, 16, 25	V <sub>CCO</sub>	Power		Output supply pins.
9, 10	nQB1, QB1	Output		Differential output pair. LVPECL interface levels.
11, 12	nQB0, QB0	Output		Differential output pair. LVPECL interface levels.
13, 30	V <sub>EE</sub>	Power		Negative supply pins.
14, 15	nQA5, QA5	Output		Differential output pair. LVPECL interface levels.
17, 18	nQA4, QA4	Output		Differential output pair. LVPECL interface levels.
19, 20	nQA3, QA3	Output		Differential output pair. LVPECL interface levels.
21, 22	nQA2, QA2	Output		Differential output pair. LVPECL interface levels.
23, 24	nQA1, QA1	Output		Differential output pair. LVPECL interface levels.
26, 27	nQA0, QA0	Output		Differential output pair. LVPECL interface levels.
28	V <sub>CCA</sub>	Power		Analog supply pin.
29	BYPASS	Input	Pulldown	A HIGH on BYPASS signal allows TEST_CLK to propagate to output dividers and bypass the PLL. a LOW on BYPASS signal allows VCO frequency to propagate to the output dividers. See Table 3. LVCMOS/LVTTL interface levels.
31	TEST_CLK	Input	Pulldown	Single-ended input test clock. LVCMOS interface levels.

NOTE: *Pulldown* refers to an internal input resistor. See Table 2, *Pin Characteristics*, for typical values.

### Table 2. Pin Characteristics

Symbol	Parameter	Test Conditions	Minimum	Typical	Maximum	Units
C <sub>IN</sub>	Input Capacitance			4		pF
R <sub>PULLDOWN</sub>	Input Pulldown Resistor			51		kΩ

## Function Table

### Table 3. Bypass Function Table

Input	Device Configuration
BYPASS	
0	PLL Mode
1	Bypass the PLL

## Absolute Maximum Ratings

NOTE: Stresses beyond those listed under *Absolute Maximum Ratings* may cause permanent damage to the device. These ratings are stress specifications only. Functional operation of product at these conditions or any conditions beyond those listed in the *DC Characteristics* or *AC Characteristics* is not implied. Exposure to absolute maximum rating conditions for extended periods may affect product reliability.

Item	Rating
Supply Voltage, $V_{CC}$	4.6V
Inputs, $V_I$ XTAL_IN Other Inputs	0V to $V_{CC}$ -0.5V to $V_{CC} + 0.5V$
Outputs, $I_O$ Continuous Current Surge Current	50mA 100mA
Package Thermal Impedance, $\theta_{JA}$	37°C/W (0 mps)
Storage Temperature, $T_{STG}$	-65°C to 150°C

## DC Electrical Characteristics

**Table 4A. Power Supply DC Characteristics,  $V_{CC} = V_{CCO} = 3.3V \pm 5\%$ ,  $V_{EE} = 0V$ ,  $T_A = 0^\circ C$  to  $70^\circ C$**

Symbol	Parameter	Test Conditions	Minimum	Typical	Maximum	Units
$V_{CC}$	Core Supply Voltage		3.135	3.3	3.465	V
$V_{CCA}$	Analog Supply Voltage		$V_{CC} - 0.33$	3.3	$V_{CC}$	V
$V_{CCO}$	Output Supply Voltage		3.135	3.3	3.465	V
$I_{EE}$	Power Supply Current				179	mA
$I_{CCA}$	Analog Supply Current				33	mA

**Table 4B. Power Supply DC Characteristics,  $V_{CC} = V_{CCO} = 2.5V \pm 5\%$ ,  $V_{EE} = 0V$ ,  $T_A = 0^\circ C$  to  $70^\circ C$**

Symbol	Parameter	Test Conditions	Minimum	Typical	Maximum	Units
$V_{CC}$	Core Supply Voltage		2.375	2.5	2.625	V
$V_{CCA}$	Analog Supply Voltage		$V_{CC} - 0.23$	2.5	$V_{CC}$	V
$V_{CCO}$	Output Supply Voltage		2.375	2.5	2.625	V
$I_{EE}$	Power Supply Current				168	mA
$I_{CCA}$	Analog Supply Current				23	mA

**Table 4C. Power Supply DC Characteristics,  $V_{CC} = 3.3V \pm 5\%$ ,  $V_{CCO} = 2.5V \pm 5\%$ ,  $V_{EE} = 0V$ ,  $T_A = 0^\circ C$  to  $70^\circ C$**

Symbol	Parameter	Test Conditions	Minimum	Typical	Maximum	Units
$V_{CC}$	Core Supply Voltage		3.135	3.3	3.465	V
$V_{CCA}$	Analog Supply Voltage		$V_{CC} - 0.33$	3.3	$V_{CC}$	V
$V_{CCO}$	Output Supply Voltage		2.375	2.5	2.625	V
$I_{EE}$	Power Supply Current				164	mA
$I_{CCA}$	Analog Supply Current				33	mA

**Table 4D. LVCMOS/LVTTL DC Characteristics,  $T_A = 0^\circ\text{C}$  to  $70^\circ\text{C}$** 

Symbol	Parameter	Test Conditions	Minimum	Typical	Maximum	Units
$V_{IH}$	Input High Voltage	$V_{CC} = 3.3\text{V}$	2		$V_{CC} + 0.3$	V
		$V_{CC} = 2.5\text{V}$	1.7		$V_{CC} + 0.3$	V
$V_{IL}$	Input Low Voltage	$V_{CC} = 3.3\text{V}$	-0.3		0.8	V
		$V_{CC} = 2.5\text{V}$	-0.3		0.7	V
$I_{IH}$	Input High Current	BYPASS, TEST_CLK $V_{CC} = V_{IN} = 3.465\text{V}$ or $2.625\text{V}$			150	$\mu\text{A}$
$I_{IL}$	Input Low Current	BYPASS, TEST_CLK $V_{CC} = 3.465\text{V}$ or $2.625\text{V}$ , $V_{IN} = 0\text{V}$	-5			$\mu\text{A}$

**Table 4E. LVPECL DC Characteristics,  $V_{CC} = V_{CCO} = 3.3\text{V} \pm 5\%$ ,  $V_{EE} = 0\text{V}$ ,  $T_A = 0^\circ\text{C}$  to  $70^\circ\text{C}$** 

Symbol	Parameter	Test Conditions	Minimum	Typical	Maximum	Units
$V_{OH}$	Output High Voltage		$V_{CCO} - 1.4$		$V_{CCO} - 0.9$	V
$V_{OL}$	Output Low Voltage		$V_{CCO} - 2.0$		$V_{CCO} - 1.7$	V
$V_{SWING}$	Peak-to-Peak Output Voltage Swing		0.6		1.0	V

**Table 4F. LVPECL DC Characteristics,  $V_{CC} = 3.3\text{V} \pm 5\%$  or  $2.5\text{V} \pm 5\%$ ,  $V_{CCO} = 2.5\text{V} \pm 5\%$ ,  $V_{EE} = 0\text{V}$ ,  $T_A = 0^\circ\text{C}$  to  $70^\circ\text{C}$** 

Symbol	Parameter	Test Conditions	Minimum	Typical	Maximum	Units
$V_{OH}$	Output High Voltage		$V_{CC} - 1.4$		$V_{CC} - 0.9$	V
$V_{OL}$	Output Low Voltage		$V_{CC} - 2.0$		$V_{CC} - 1.5$	V
$V_{SWING}$	Peak-to-Peak Output Voltage Swing		0.4		1.0	V

**Table 5. Crystal Characteristics**

Parameter	Test Conditions	Minimum	Typical	Maximum	Units
Mode of Oscillation		Fundamental			
Frequency			25		MHz
Equivalent Series Resistance (ESR)				50	$\Omega$
Shunt Capacitance				7	pF

## AC Electrical Characteristics

**Table 6A. AC Characteristics,  $V_{CC} = V_{CCO} = 3.3V \pm 5\%$ ,  $V_{EE} = 0V$ ,  $T_A = 0^\circ C$  to  $70^\circ C$**

Symbol	Parameter	Test Conditions	Minimum	Typical	Maximum	Units
$f_{OUT}$	Output Frequency			156.25		MHz
$f_{jit(cc)}$	Cycle-to-Cycle Jitter; NOTE 1				40	ps
$f_{jit(\emptyset)}$	RMS Phase Jitter, (Random); NOTE 2	156.25MHz, Integration Range: 1.875MHz - 20MHz		0.39		ps
$t_R / t_F$	Output Rise/Fall Time	20% to 80%	200		700	ps
odc	Output Duty Cycle		45		55	%
$t_{LOCK}$	PLL Lock Time				100	ms

NOTE: Electrical parameters are guaranteed over the specified ambient operating temperature range, which is established when the device is mounted in a test socket with maintained transverse airflow greater than 500 lfm. The device will meet specifications after thermal equilibrium has been reached under these conditions.

NOTE 1: This parameter is defined in accordance with JEDEC standard 65.

NOTE 2: Refer to phase noise plot.

**Table 6B. AC Characteristics,  $V_{CC} = V_{CCO} = 2.5V \pm 5\%$ ,  $V_{EE} = 0V$ ,  $T_A = 0^\circ C$  to  $70^\circ C$**

Symbol	Parameter	Test Conditions	Minimum	Typical	Maximum	Units
$f_{OUT}$	Output Frequency			156.25		MHz
$f_{jit(cc)}$	Cycle-to-Cycle Jitter; NOTE 1				35	ps
$f_{jit(\emptyset)}$	RMS Phase Jitter, (Random)	156.25MHz, Integration Range: 1.875MHz - 20MHz		0.49		ps
$t_R / t_F$	Output Rise/Fall Time	20% to 80%	200		700	ps
odc	Output Duty Cycle		45		55	%
$t_{LOCK}$	PLL Lock Time				100	ms

NOTE: Electrical parameters are guaranteed over the specified ambient operating temperature range, which is established when the device is mounted in a test socket with maintained transverse airflow greater than 500 lfm. The device will meet specifications after thermal equilibrium has been reached under these conditions.

NOTE 1: This parameter is defined in accordance with JEDEC standard 65.

**Table 6C. AC Characteristics,  $V_{CC} = 3.3V \pm 5\%$ ,  $V_{CCO} = 2.5V \pm 5\%$ ,  $V_{EE} = 0V$ ,  $T_A = 0^\circ C$  to  $70^\circ C$**

Symbol	Parameter	Test Conditions	Minimum	Typical	Maximum	Units
$f_{OUT}$	Output Frequency			156.25		MHz
$f_{jit(cc)}$	Cycle-to-Cycle Jitter; NOTE 1				40	ps
$f_{jit(\emptyset)}$	RMS Phase Jitter, (Random)	156.25MHz, Integration Range: 1.875MHz - 20MHz		0.40		ps
$t_R / t_F$	Output Rise/Fall Time	20% to 80%	200		700	ps
odc	Output Duty Cycle		45		55	%
$t_{LOCK}$	PLL Lock Time				100	ms

NOTE: Electrical parameters are guaranteed over the specified ambient operating temperature range, which is established when the device is mounted in a test socket with maintained transverse airflow greater than 500 lfm. The device will meet specifications after thermal equilibrium has been reached under these conditions.

NOTE 1: This parameter is defined in accordance with JEDEC standard 65.

Typical Phase Noise at 156.25MHz @ 3.3V

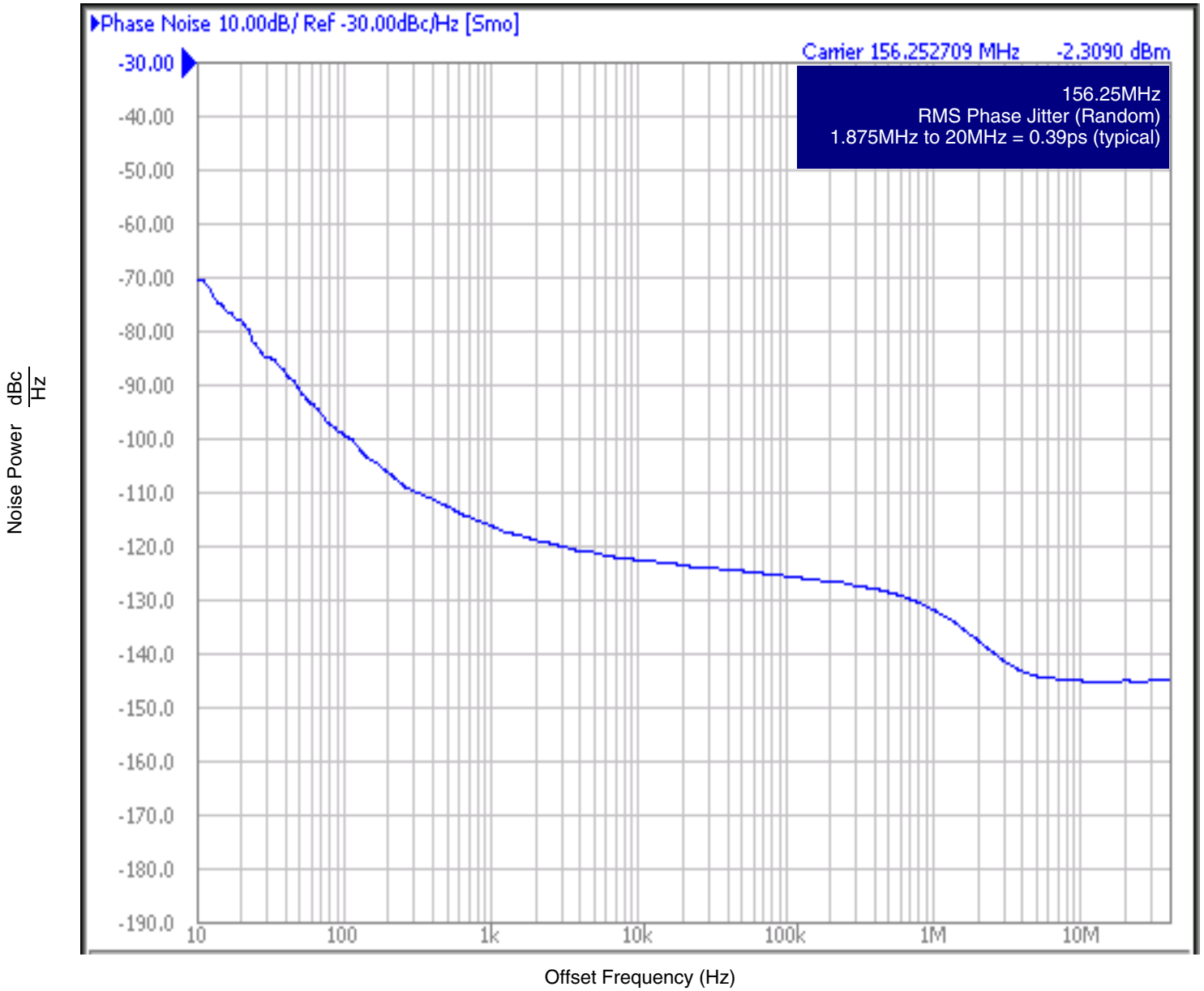

## Parameter Measurement Information

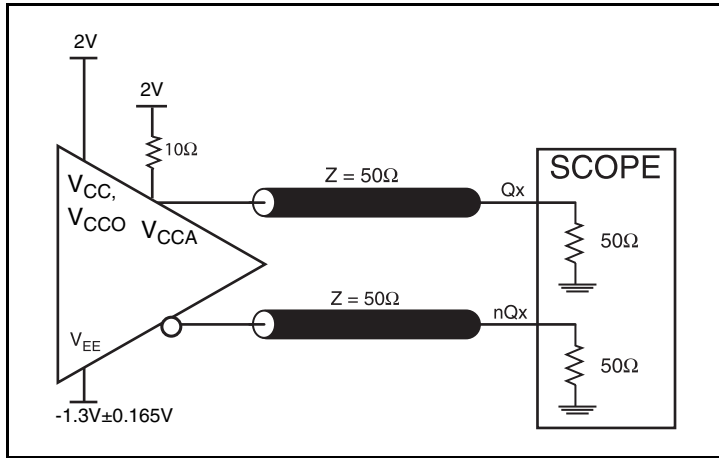

3.3V Core/3.3V LVPECL Output Load Test Circuit

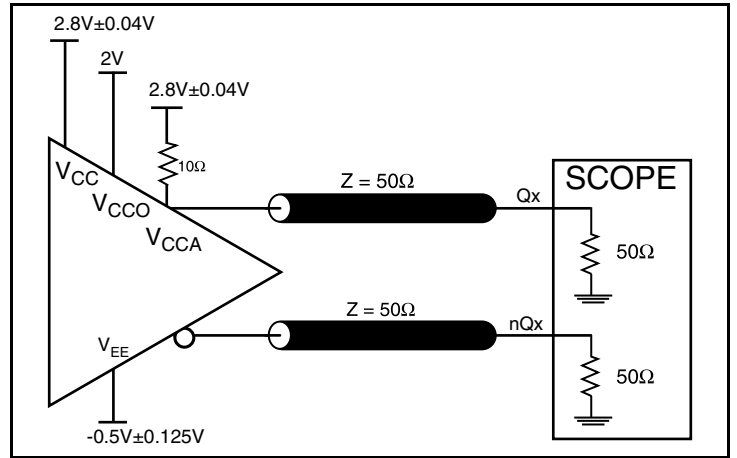

3.3V Core/2.5V LVPECL Output Load Test Circuit

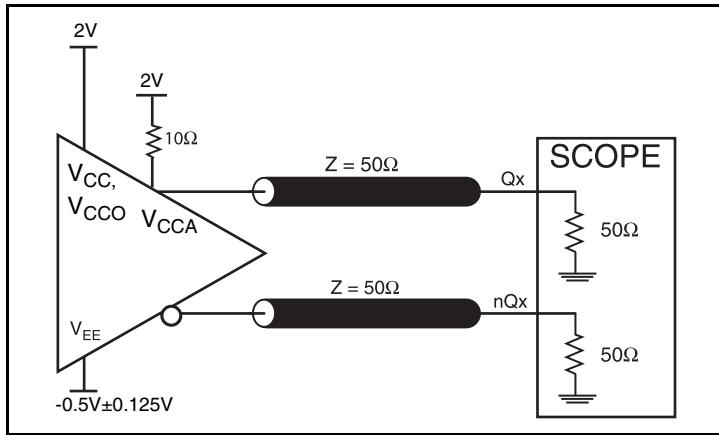

2.5V Core/2.5V LVPECL Output Load Test Circuit

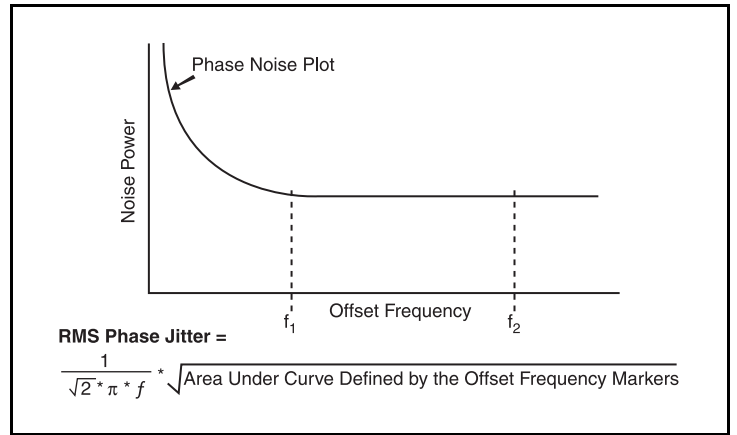

RMS Phase Jitter

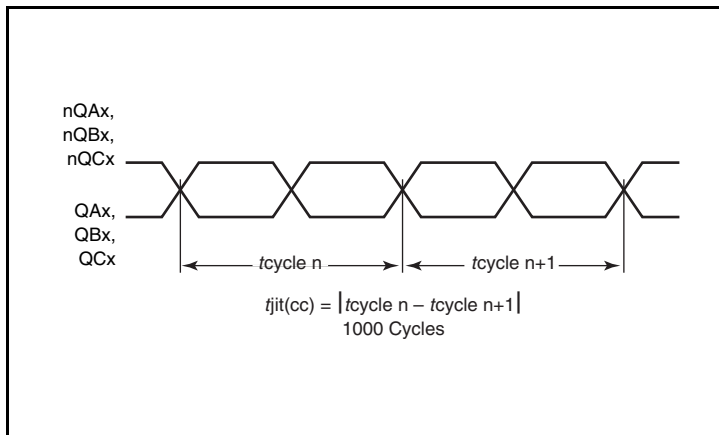

Cycle-to-Cycle Jitter

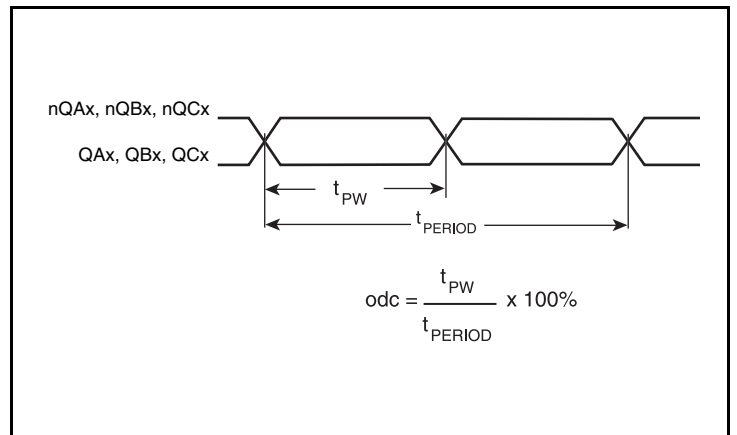

Output Duty Cycle/Pulse Width/Period

Parameter Measurement Information, continued

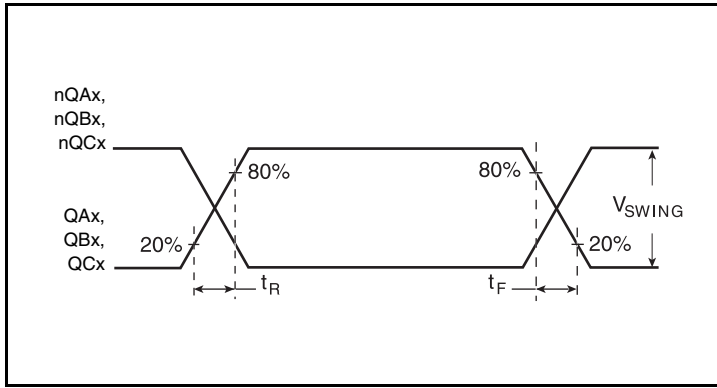

LVPECL Output Rise/Fall Time

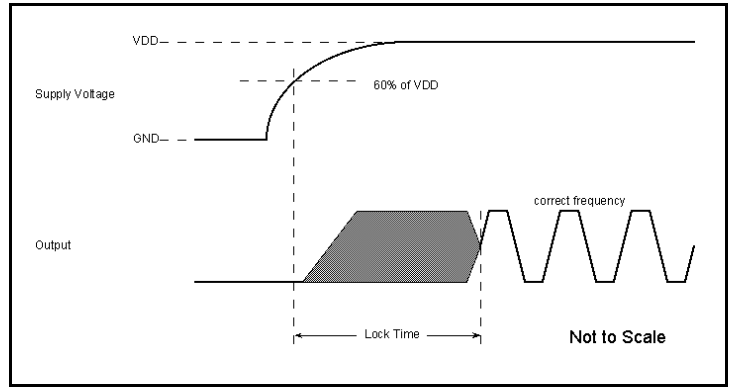

Lock Time



## Applications Information

### Recommendations for Unused Input and Output Pins

#### Inputs:

##### TEST\_CLK Input

For applications not requiring the use of the test clock, it can be left floating. Though not required, but for additional protection, a 1k $\Omega$  resistor can be tied from the TEST\_CLK to ground.

##### Crystal Inputs

For applications not requiring the use of the crystal oscillator input, both XTAL\_IN and XTAL\_OUT can be left floating. Though not required, but for additional protection, a 1k $\Omega$  resistor can be tied from XTAL\_IN to ground.

##### LVC MOS Control Pins

All control pins have internal pulldowns; additional resistance is not required but can be added for additional protection. A 1k $\Omega$  resistor can be used.

#### Outputs:

##### LVPECL Outputs

All unused LVPECL outputs can be left floating. We recommend that there is no trace attached. Both sides of the differential output pair should either be left floating or terminated.

### Power Supply Filtering Technique

As in any high speed analog circuitry, the power supply pins are vulnerable to random noise. To achieve optimum jitter performance, power supply isolation is required. The ICS843156 provides separate power supplies to isolate any high switching noise from the outputs to the internal PLL.  $V_{CC}$ ,  $V_{CCA}$  and  $V_{CCO}$  should be individually connected to the power supply plane through vias, and 0.01 $\mu$ F bypass capacitors should be used for each pin. *Figure 1* illustrates this for a generic  $V_{CC}$  pin and also shows that  $V_{CCA}$  requires that an additional 10 $\Omega$  resistor along with a 10 $\mu$ F bypass capacitor be connected to the  $V_{CCA}$  pin.

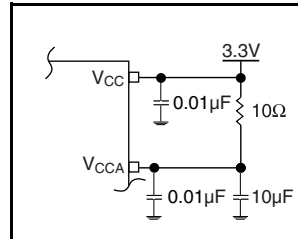

Figure 1. Power Supply Filtering

### Crystal Input Interface

The ICS843156 has been characterized with 18pF parallel resonant crystals. The capacitor values, C1 and C2, shown in *Figure 2* below were determined using a 25MHz, 18pF parallel resonant crystal and were chosen to minimize the ppm error. The optimum C1 and C2 values can be slightly adjusted for different board layouts.

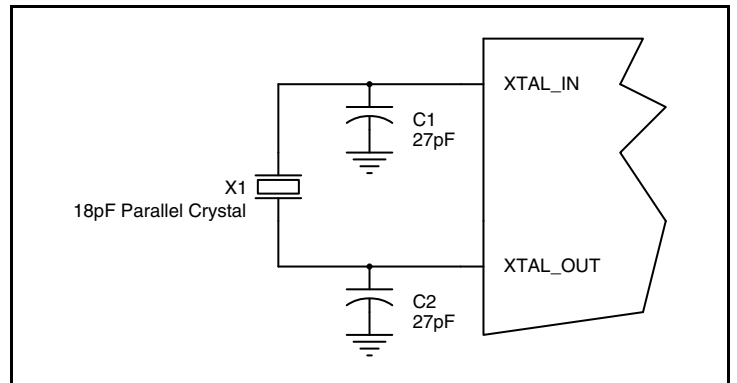

Figure 2. Crystal Input Interface

## Overdriving the XTAL Interface

The XTAL\_IN input can be overdriven by an LVCMOS driver or by one side of a differential driver through an AC coupling capacitor. The XTAL\_OUT pin can be left floating. The amplitude of the input signal should be between 500mV and 1.8V and the slew rate should not be less than 0.2V/nS. For 3.3V LVCMOS inputs, the amplitude must be reduced from full swing to at least half the swing in order to prevent signal interference with the power rail and to reduce internal noise. *Figure 3A* shows an example of the interface diagram for a high speed 3.3V LVCMOS driver. This configuration requires that the sum of the output impedance of the driver ( $R_o$ ) and the series resistance ( $R_s$ ) equals the transmission line impedance. In addition, matched termination at the crystal input will attenuate the signal in half. This

can be done in one of two ways. First,  $R_1$  and  $R_2$  in parallel should equal the transmission line impedance. For most 50Ω applications,  $R_1$  and  $R_2$  can be 100Ω. This can also be accomplished by removing  $R_1$  and changing  $R_2$  to 50Ω. The values of the resistors can be increased to reduce the loading for a slower and weaker LVCMOS driver. *Figure 3B* shows an example of the interface diagram for an LVPECL driver. This is a standard LVPECL termination with one side of the driver feeding the XTAL\_IN input. It is recommended that all components in the schematics be placed in the layout. Though some components might not be used, they can be utilized for debugging purposes. The datasheet specifications are characterized and guaranteed by using a quartz crystal as the input.

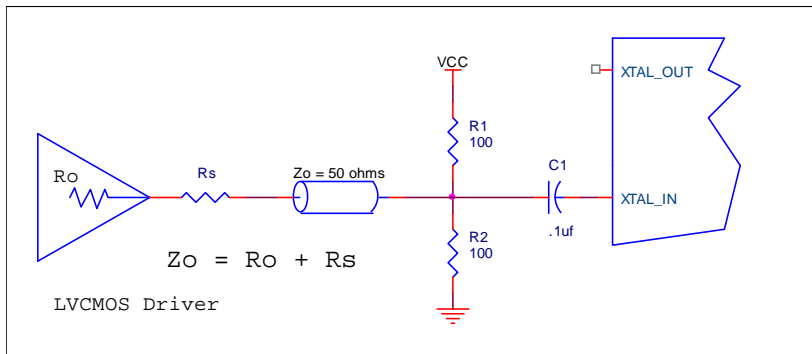

Figure 3A. General Diagram for LVCMOS Driver to XTAL Input Interface

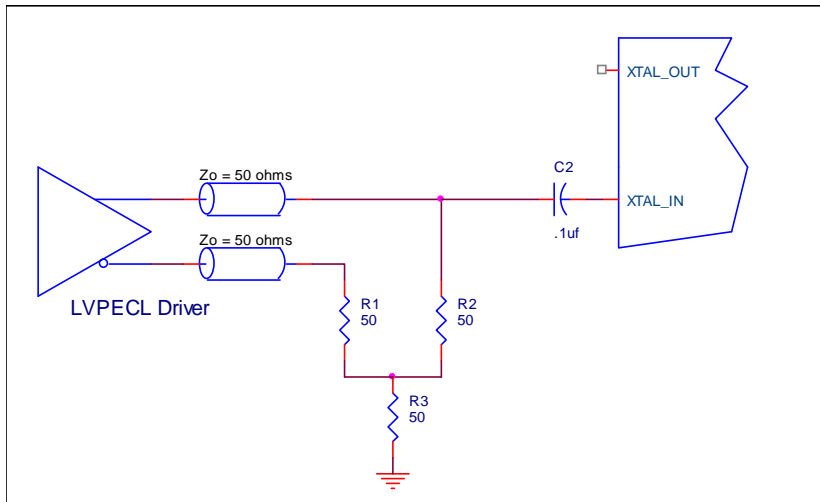

Figure 3B. General Diagram for LVPECL Driver to XTAL Input Interface

## Termination for 3.3V LVPECL Outputs

The clock layout topology shown below is a typical termination for LVPECL outputs. The two different layouts mentioned are recommended only as guidelines.

The differential outputs are low impedance follower outputs that generate ECL/LVPECL compatible outputs. Therefore, terminating resistors (DC current path to ground) or current sources must be used for functionality. These outputs are designed to drive 50Ω

transmission lines. Matched impedance techniques should be used to maximize operating frequency and minimize signal distortion.

Figures 4A and 4B show two different layouts which are recommended only as guidelines. Other suitable clock layouts may exist and it would be recommended that the board designers simulate to guarantee compatibility across all printed circuit and clock component process variations.

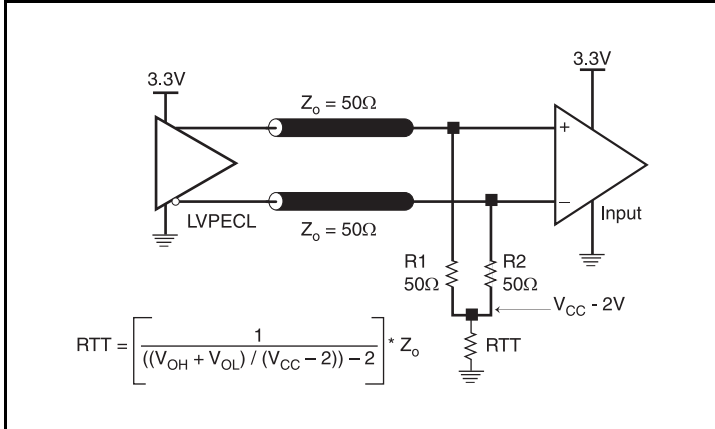

Figure 4A. 3.3V LVPECL Output Termination

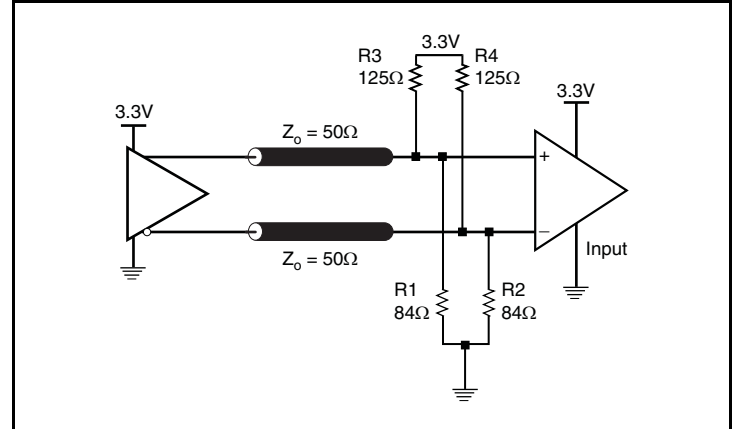

Figure 4B. 3.3V LVPECL Output Termination

## Termination for 2.5V LVPECL Outputs

Figure 5A and Figure 5B show examples of termination for 2.5V LVPECL driver. These terminations are equivalent to terminating  $50\Omega$  to  $V_{CC0} - 2V$ . For  $V_{CC0} = 2.5V$ , the  $V_{CC0} - 2V$  is very close to ground

level. The R3 in Figure 5B can be eliminated and the termination is shown in Figure 5C.

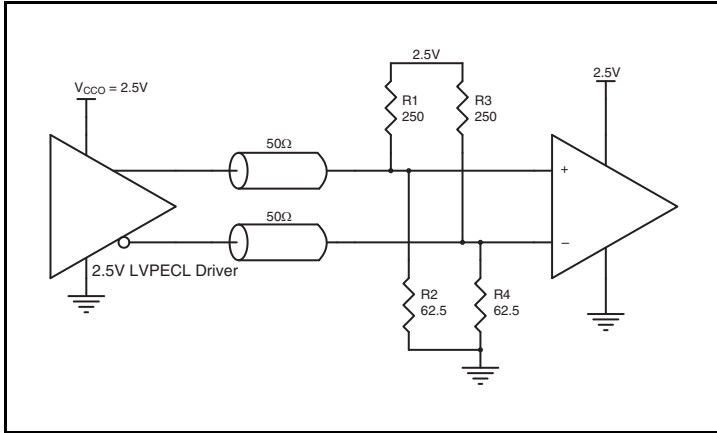

Figure 5A. 2.5V LVPECL Driver Termination Example

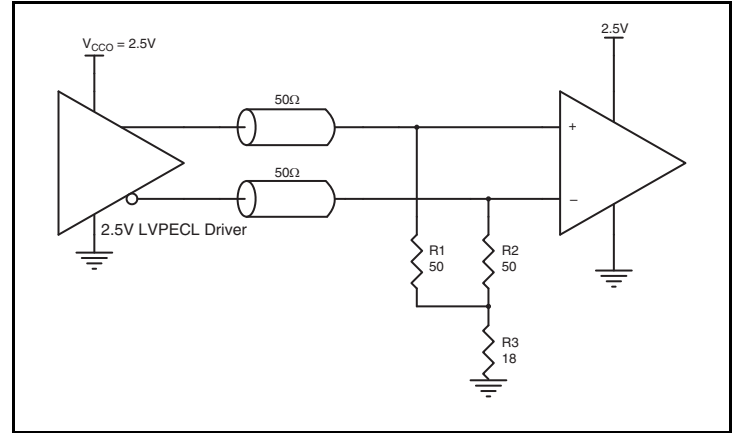

Figure 5B. 2.5V LVPECL Driver Termination Example

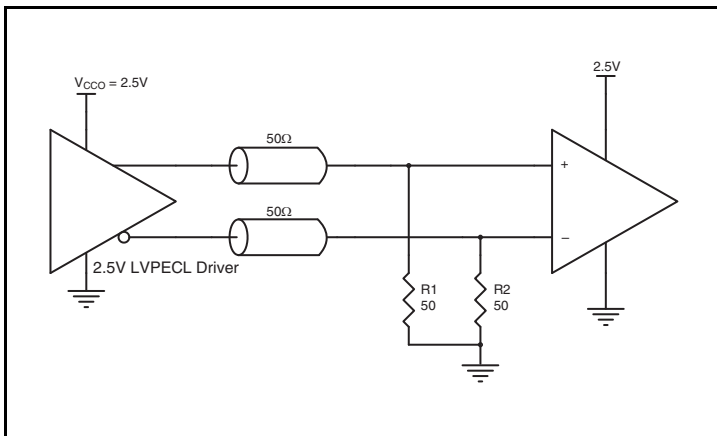

Figure 5C. 2.5V LVPECL Driver Termination Example

## VFQFN EPAD Thermal Release Path

In order to maximize both the removal of heat from the package and the electrical performance, a land pattern must be incorporated on the Printed Circuit Board (PCB) within the footprint of the package corresponding to the exposed metal pad or exposed heat slug on the package, as shown in *Figure 6*. The solderable area on the PCB, as defined by the solder mask, should be at least the same size/shape as the exposed pad/slug area on the package to maximize the thermal/electrical performance. Sufficient clearance should be designed on the PCB between the outer edges of the land pattern and the inner edges of pad pattern for the leads to avoid any shorts.

While the land pattern on the PCB provides a means of heat transfer and electrical grounding from the package to the board through a solder joint, thermal vias are necessary to effectively conduct from the surface of the PCB to the ground plane(s). The land pattern must be connected to ground through these vias. The vias act as “heat pipes”. The number of vias (i.e. “heat pipes”) are application specific

and dependent upon the package power dissipation as well as electrical conductivity requirements. Thus, thermal and electrical analysis and/or testing are recommended to determine the minimum number needed. Maximum thermal and electrical performance is achieved when an array of vias is incorporated in the land pattern. It is recommended to use as many vias connected to ground as possible. It is also recommended that the via diameter should be 12 to 13mils (0.30 to 0.33mm) with 1oz copper via barrel plating. This is desirable to avoid any solder wicking inside the via during the soldering process which may result in voids in solder between the exposed pad/slug and the thermal land. Precautions should be taken to eliminate any solder voids between the exposed heat slug and the land pattern. Note: These recommendations are to be used as a guideline only. For further information, please refer to the Application Note on the Surface Mount Assembly of Amkor’s Thermally/Electrically Enhance Lead frame Base Package, Amkor Technology.

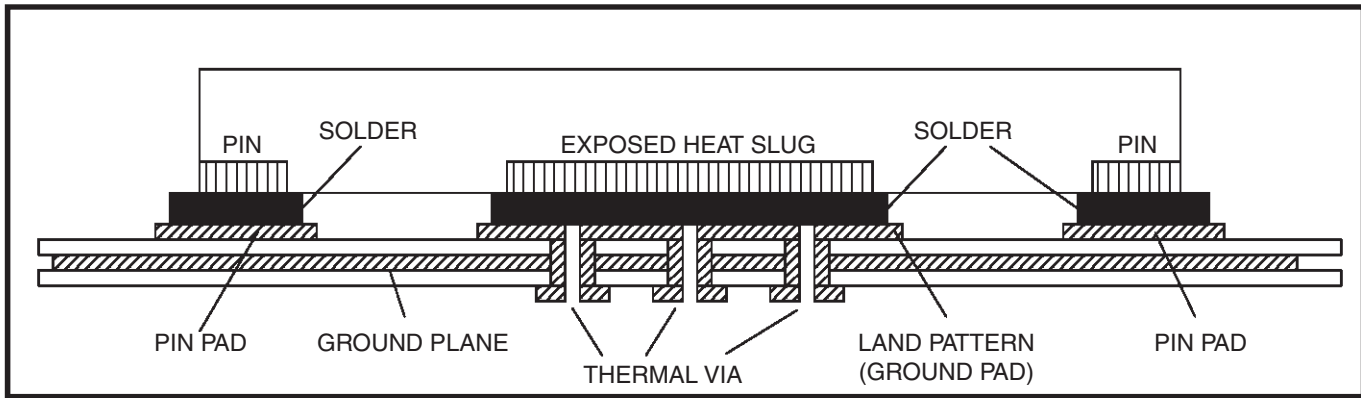

**Figure 6. P.C. Assembly for Exposed Pad Thermal Release Path – Side View (drawing not to scale)**

## Power Considerations

This section provides information on power dissipation and junction temperature for the ICS843156. Equations and example calculations are also provided.

### 1. Power Dissipation.

The total power dissipation for the ICS843156 is the sum of the core power plus the power dissipation in the load(s). The following is the power dissipation for  $V_{CCO} = 3.3V + 5\% = 3.465V$ , which gives worst case results.

NOTE: Please refer to Section 3 for details on calculating power dissipation in the load.

- Power (core)<sub>MAX</sub> =  $V_{CCO\_MAX} * I_{EE\_MAX} = 3.465V * 179mA = \mathbf{620.235mW}$
- Power (outputs)<sub>MAX</sub> = **30mW/Loaded Output pair**  
If all outputs are loaded, the total power is  $10 * 30mW = \mathbf{300mW}$

**Total Power**<sub>MAX</sub> (3.3V, with all outputs switching) =  $620.235mW + 300mW = \mathbf{920.235mW}$

### 2. Junction Temperature.

Junction temperature,  $T_j$ , is the temperature at the junction of the bond wire and bond pad directly affects the reliability of the device. The maximum recommended junction temperature is 125°C. Limiting the internal transistor junction temperature,  $T_j$ , to 125°C ensures that the bond wire and bond pad temperature remains below 125°C.

The equation for  $T_j$  is as follows:  $T_j = \theta_{JA} * Pd\_total + T_A$

$T_j$  = Junction Temperature

$\theta_{JA}$  = Junction-to-Ambient Thermal Resistance

$Pd\_total$  = Total Device Power Dissipation (example calculation is in section 1 above)

$T_A$  = Ambient Temperature

In order to calculate junction temperature, the appropriate junction-to-ambient thermal resistance  $\theta_{JA}$  must be used. Assuming no air flow and a multi-layer board, the appropriate value is 37°C/W per Table 7 below.

Therefore,  $T_j$  for an ambient temperature of 70°C with all outputs switching is:

$$70^\circ\text{C} + 0.920\text{W} * 37^\circ\text{C/W} = 1046^\circ\text{C}. \text{ This is below the limit of } 125^\circ\text{C}.$$

This calculation is only an example.  $T_j$  will obviously vary depending on the number of loaded outputs, supply voltage, air flow and the type of board (multi-layer).

**Table 7. Thermal Resistance  $\theta_{JA}$  for 32 Lead VFQFN, Forced Convection**

$\theta_{JA}$ by Velocity			
Meters per Second	0	1	2.5
Multi-Layer PCB, JEDEC Standard Test Boards	37.0°C/W	32.4°C/W	29.0°C/W

### 3. Calculations and Equations.

The purpose of this section is to calculate the power dissipation for the LVPECL output pairs.

The LVPECL output driver circuit and termination are shown in *Figure 7*.

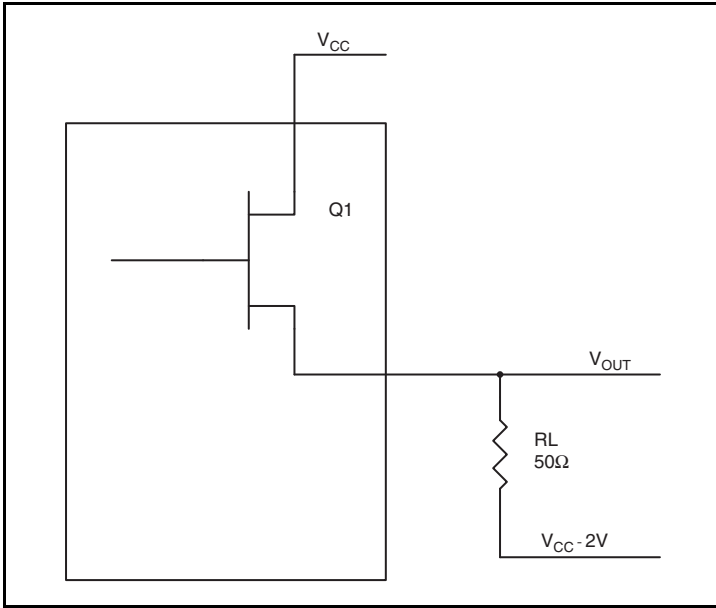

**Figure 7. LVPECL Driver Circuit and Termination**

To calculate power dissipation per output pair due to loading, use the following equations which assume a 50Ω load, and a termination voltage of  $V_{CCO} - 2V$ .

- For logic high,  $V_{OUT} = V_{OH\_MAX} = V_{CCO\_MAX} - 0.9V$   
 $(V_{CCO\_MAX} - V_{OH\_MAX}) = 0.9V$
- For logic low,  $V_{OUT} = V_{OL\_MAX} = V_{CCO\_MAX} - 1.7V$   
 $(V_{CCO\_MAX} - V_{OL\_MAX}) = 1.7V$

$Pd\_H$  is power dissipation when the output drives high.

$Pd\_L$  is the power dissipation when the output drives low.

$$Pd\_H = [(V_{OH\_MAX} - (V_{CCO\_MAX} - 2V))/R_L] * (V_{CCO\_MAX} - V_{OH\_MAX}) = [(2V - (V_{CCO\_MAX} - V_{OH\_MAX}))/R_L] * (V_{CCO\_MAX} - V_{OH\_MAX}) = [(2V - 0.9V)/50\Omega] * 0.9V = \mathbf{19.8mW}$$

$$Pd\_L = [(V_{OL\_MAX} - (V_{CCO\_MAX} - 2V))/R_L] * (V_{CCO\_MAX} - V_{OL\_MAX}) = [(2V - (V_{CCO\_MAX} - V_{OL\_MAX}))/R_L] * (V_{CCO\_MAX} - V_{OL\_MAX}) = [(2V - 1.7V)/50\Omega] * 1.7V = \mathbf{10.2mW}$$

Total Power Dissipation per output pair =  $Pd\_H + Pd\_L = \mathbf{30mW}$

## Reliability Information

**Table 8.  $\theta_{JA}$  vs. Air Flow Table for a 32 Lead VFQFN**

$\theta_{JA}$ vs. Air Flow			
Meters per Second	0	1	2.5
Multi-Layer PCB, JEDEC Standard Test Boards	37.0°C/W	32.4°C/W	29.0°C/W

## Transistor Count

The transistor count for ICS843156 is: 3059



# Package Outline and Package Dimensions

## Package Outline - K Suffix for 32 Lead VFQFN

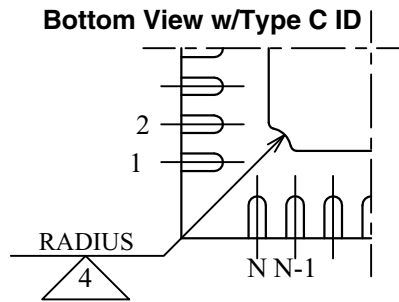
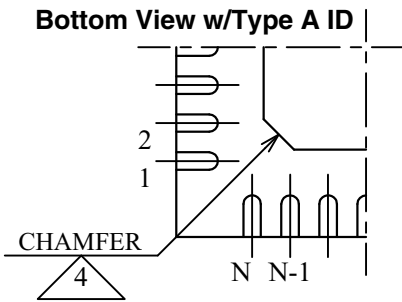
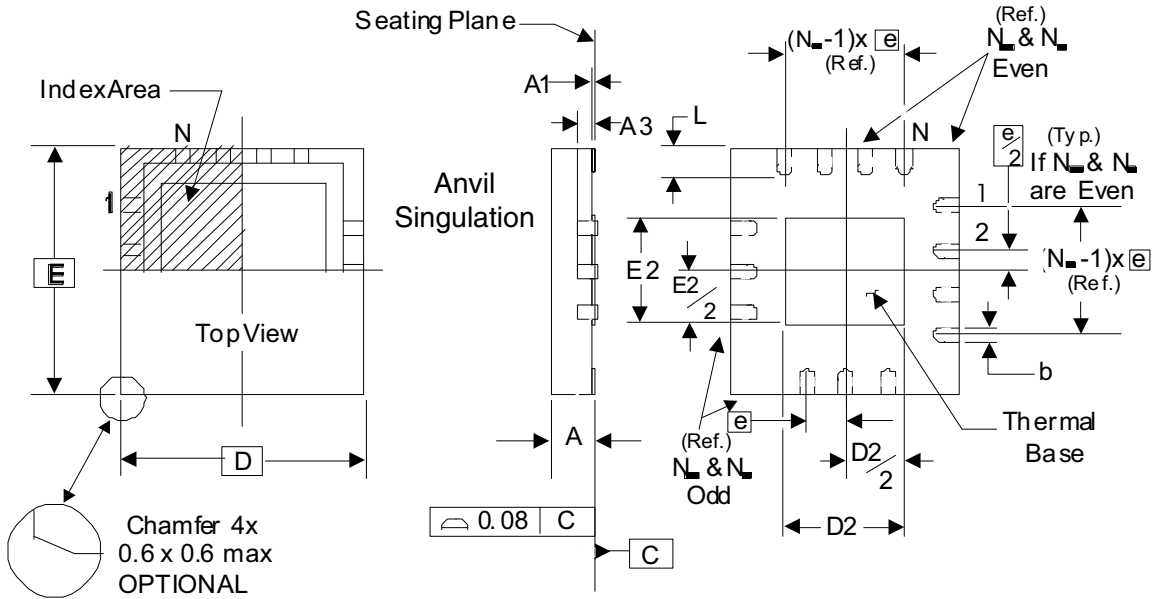

There are 2 methods of indicating pin 1 corner at the back of the VFQFN package:

1. Type A: Chamfer on the paddle (near pin 1)
2. Type C: Mouse bite on the paddle (near pin 1)

**Table 9. Package Dimensions**

JEDEC Variation: VHHD-2/-4			
All Dimensions in Millimeters			
Symbol	Minimum	Nominal	Maximum
N	32		
A	0.80		1.00
A1	0		0.05
A3	0.25 Ref.		
b	0.18	0.25	0.30
$N_D & N_E$	8		
D & E	5.00 Basic		
D2 & E2	3.0		3.3
e	0.50 Basic		
L	0.30	0.40	0.50

NOTE: The following package mechanical drawing is a generic drawing that applies to any pin count VFQFN package. This drawing is not intended to convey the actual pin count or pin layout of this device. The pin count and pinout are shown on the front page. The package dimensions are in Table 9 below.

Reference Document: JEDEC Publication 95, MO-220

## Ordering Information

Table 10. Ordering Information

Part/Order Number	Marking	Package	Shipping Packaging	Temperature
843156AKLF	ICS843156AL	"Lead-Free" 32 Lead VFQFN	Tray	0°C to 70°C
843156AKLFT	ICS843156AL	"Lead-Free" 32 Lead VFQFN	Tape & Reel	0°C to 70°C

## Revision History Sheet

Rev	Table	Page	Description of Change	Date
A		10	VFQFN EPAD Thermal Release Path	10/25/12
B		1 8 10 17	Per Errata #108 Pin Assignment - corrected pins 9 - 12. Added E-Pad dimensions. Parameter Measurement Information - added Lock Time Diagram. Updated Application Note, <i>Overdriving the XTAL Interface</i> . Updated Package Outline.	11/28/12
B			Product Discontinuation Notice - Last time buy expires May 6, 2017. PDN CQ-16-01	5/26/16



## IMPORTANT NOTICE AND DISCLAIMER

RENESAS ELECTRONICS CORPORATION AND ITS SUBSIDIARIES (“RENESAS”) PROVIDES TECHNICAL SPECIFICATIONS AND RELIABILITY DATA (INCLUDING DATASHEETS), DESIGN RESOURCES (INCLUDING REFERENCE DESIGNS), APPLICATION OR OTHER DESIGN ADVICE, WEB TOOLS, SAFETY INFORMATION, AND OTHER RESOURCES “AS IS” AND WITH ALL FAULTS, AND DISCLAIMS ALL WARRANTIES, EXPRESS OR IMPLIED, INCLUDING, WITHOUT LIMITATION, ANY IMPLIED WARRANTIES OF MERCHANTABILITY, FITNESS FOR A PARTICULAR PURPOSE, OR NON-INFRINGEMENT OF THIRD-PARTY INTELLECTUAL PROPERTY RIGHTS.

These resources are intended for developers who are designing with Renesas products. You are solely responsible for (1) selecting the appropriate products for your application, (2) designing, validating, and testing your application, and (3) ensuring your application meets applicable standards, and any other safety, security, or other requirements. These resources are subject to change without notice. Renesas grants you permission to use these resources only to develop an application that uses Renesas products. Other reproduction or use of these resources is strictly prohibited. No license is granted to any other Renesas intellectual property or to any third-party intellectual property. Renesas disclaims responsibility for, and you will fully indemnify Renesas and its representatives against, any claims, damages, costs, losses, or liabilities arising from your use of these resources. Renesas' products are provided only subject to Renesas' Terms and Conditions of Sale or other applicable terms agreed to in writing. No use of any Renesas resources expands or otherwise alters any applicable warranties or warranty disclaimers for these products.

(Disclaimer Rev.1.01)

### Corporate Headquarters

TOYOSU FORESIA, 3-2-24 Toyosu,  
Koto-ku, Tokyo 135-0061, Japan  
[www.renesas.com](http://www.renesas.com)

### Trademarks

Renesas and the Renesas logo are trademarks of Renesas Electronics Corporation. All trademarks and registered trademarks are the property of their respective owners.

### Contact Information

For further information on a product, technology, the most up-to-date version of a document, or your nearest sales office, please visit [www.renesas.com/contact-us/](http://www.renesas.com/contact-us/).