

## General Description

The ICS849N212I is a highly flexible FemtoClock® NG general purpose, low phase noise Frequency Translator / Synthesizer with alarm and monitoring functions suitable for networking and communications applications. It is able to generate any output frequency in the 1MHz - 250MHz range (see Table 3 for details). A wide range of input reference clocks and a range of low-cost fundamental mode crystal frequencies may be used as the source for the output frequency.

The ICS849N212I has three operating modes to support a very broad spectrum of applications:

### 1) Frequency Synthesizer

- Synthesizes output frequencies from a 16MHz - 40MHz fundamental mode crystal.
- Fractional feedback division is used, so there are no requirements for any specific crystal frequency to produce the desired output frequency with a high degree of accuracy.

### 2) High-Bandwidth Frequency Translator

- Applications: PCI Express, Computing, General Purpose
- Translates any input clock in the 16MHz - 710MHz frequency range into any supported output frequency.
- This mode has a high PLL loop bandwidth in order to track input reference changes, such as Spread-Spectrum Clock modulation, so it will not attenuate much jitter on the input reference.

### 3) Low-Bandwidth Frequency Translator

- Applications: Networking & Communications.
- Translates any input clock in the 8kHz - 710MHz frequency range into any supported output frequency.
- This mode supports PLL loop bandwidths in the 10Hz - 580Hz range and makes use of an external crystal to provide significant jitter attenuation.

This device provides two factory-programmed default power-up configurations burned into One-Time Programmable (OTP) memory. The configuration to be used is selected by the CONFIG pin. The two configurations are specified by the customer and are programmed by IDT during the final test phase from an on-hand stock of blank devices. The two configurations may be completely independent of one another.

One usage example might be to install the device on a line card with two optional daughter cards: an OC-3 option (configuration 0) requiring a 155.52MHz LVDS clock translated from a 19.44MHz input and a Gigabit Ethernet option (configuration 1) requiring a 125MHz LVPECL clock translated from the same 19.44MHz input reference.

To implement other configurations, these power-up default settings can be overwritten after power-up using the I<sup>2</sup>C interface and the device can be completely reconfigured. However, these settings would have to be re-written each time the device powers-up.

## Features

- Fourth generation FemtoClock® NG technology
- Universal Frequency Translator/Frequency Synthesizer
- Two outputs
  - One programmable as LVPECL or LVDS
  - One LVCMOS
  - Both outputs may be set to use 2.5V or 3.3V output levels
  - Programmable output frequency: 1.0MHz to 250MHz
- Two differential inputs support the following input types: LVPECL, LVDS, LVHSTL, HCSL
- Input frequency range: 8kHz - 710MHz
- Crystal input frequency range: 16MHz - 40MHz
- Two factory-set register configurations for power-up default state
  - Power-up default configuration pin or register selectable
  - Configurations customized via One-Time Programmable ROM
  - Settings may be overwritten after power-up via I<sup>2</sup>C
  - I<sup>2</sup>C Serial interface for register programming
- RMS phase jitter at 125MHz, using a 40MHz crystal (12kHz - 20MHz): 558fs (typical), Low Bandwidth Mode (FracN)
- RMS phase jitter at 125MHz, using a 100MHz input clock (12kHz - 20MHz): 388fs (typical), High Bandwidth Mode (Integer FB)
- Output supply voltage modes:
  - $V_{CC}/V_{CCA}/V_{CCO}$   
3.3V/3.3V/3.3V
  - 3.3V/3.3V/2.5V (LVPECL only)
  - 2.5V/2.5V/2.5V
- -40°C to 85°C ambient operating temperature
- Available in lead-free (RoHS 6) package

## Pin Assignment

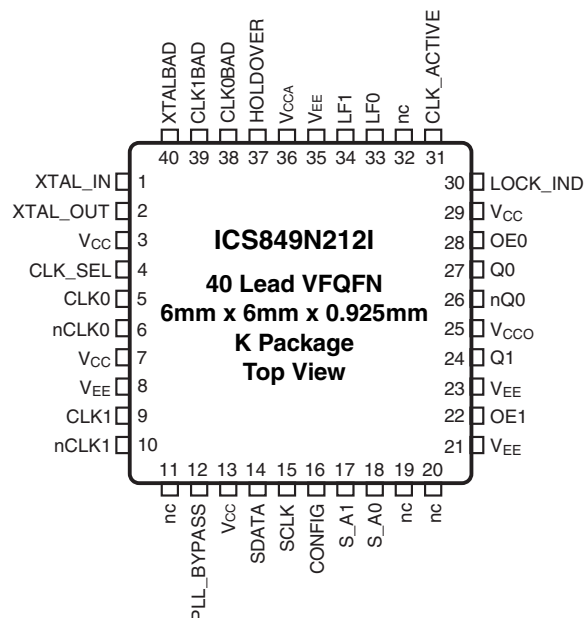

# Complete Block Diagram

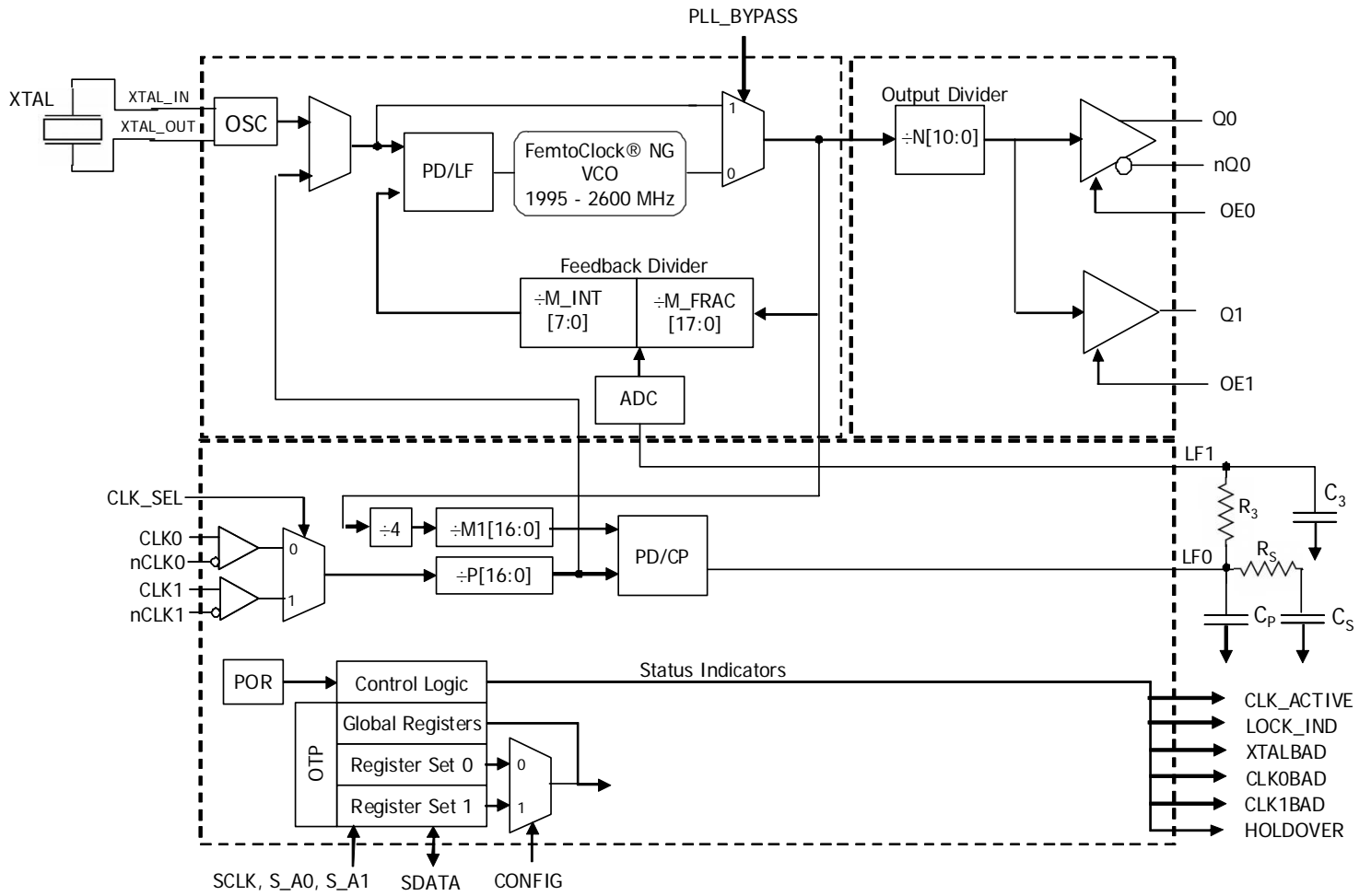

**Table 1. Pin Descriptions**

Number	Name	Type		Description
1 2	XTAL_IN XTAL_OUT	Input		Crystal oscillator interface designed for 12pF parallel resonant crystals. XTAL_IN (pin 1) is the input and XTAL_OUT (pin 2) is the output.
3, 7, 13, 29	V <sub>CC</sub>	Power		Core supply pins. All must be either 3.3V or 2.5V.
4	CLK_SEL	Input	Pulldown	Input clock select. Selects the active differential clock input. LVCMOS/LVTTL Interface Levels. 0 = CLK0, nCLK0 (default) 1 = CLK1, nCLK1
5	CLK0	Input	Pulldown	Non-inverting differential clock input.
6	nCLK0	Input	Pullup/ Pulldown	Inverting differential clock input. V <sub>CC</sub> /2 default when left floating (set by the internal pullup and pulldown resistors).
8, 21, 23, 35	V <sub>EE</sub>	Power		Negative supply pins.
9	CLK1	Input	Pulldown	Non-inverting differential clock input.
10	nCLK1	Input	Pullup/ Pulldown	Inverting differential clock input. V <sub>CC</sub> /2 default when left floating (set by the internal pullup and pulldown resistors).
11, 19, 20, 32	nc	Unused		No connect. These pins are to be left unconnected.
12	PLL_BYPASS	Input	Pulldown	Bypasses the VCXO PLL. In Bypass mode, outputs are clocked off the falling edge of the input reference. LVCMOS/LVTTL Interface Levels. 0 = PLL mode (default) 1 = PLL Bypassed
14	SDATA	I/O	Pullup	I <sup>2</sup> C Data Input/Output. Open drain.
15	SCLK	Input	Pullup	I <sup>2</sup> C Clock Input. LVCMOS/LVTTL Interface Levels.
16	CONFIG	Input	Pulldown	Configuration Pin. Selects between one of two factory programmable pre-set power-up default configurations. The two configurations can have different output/input frequency translation ratios, different PLL loop bandwidths, etc. These default configurations can be overwritten after power-up via I <sup>2</sup> C if the user so desires. LVCMOS/LVTTL Interface Levels. 0 = Configuration 0 (default) 1 = Configuration 1
17	S_A1	Input	Pulldown	I <sup>2</sup> C Address Bit 1. LVCMOS/LVTTL Interface Levels.
18	S_A0	Input	Pulldown	I <sup>2</sup> C Address Bit 0. LVCMOS/LVTTL Interface Levels.
22	OE1	Input	Pullup	Active High Output Enable for Q1, nQ1. LVCMOS/LVTTL Interface Levels. 0 = Output pins high-impedance 1 = Output switching (default)
24	Q1	Output		Single-ended clock output. LVCMOS/LVTTL Interface Levels.
25	V <sub>CCO</sub>	Power		Output supply pin for differential Q0, nQ0 and single-ended Q1 outputs. Either 2.5V or 3.3V.
26, 27	nQ0, Q0	Output		Differential output pair. Output type is programmable to LVDS or LVPECL interface levels.
28	OE0	Input	Pullup	Active High Output Enable for Q0, nQ0. LVCMOS/LVTTL Interface Levels. 0 = Output pins high-impedance 1 = Output switching (default)
30	LOCK_IND	Output		Lock Indicator - indicates that the PLL is in a locked condition. LVCMOS/LVTTL interface levels.
31	CLK_ACTIVE	Output		Indicates which of the two differential clock inputs is currently selected. LVCMOS/LVTTL Interface Levels. 0 - CLK0/nCLK0 differential input pair 1 - CLK1/nCLK1 differential input pair

Number	Name	Type	Description
33, 34	LF0, LF1	Analog I/O	Loop filter connection node pins. LF0 is the output. LF1 is the input.
36	V <sub>CCA</sub>	Power	Analog supply voltage. See Applications section for details on how to connect this pin.
37	HOLDOVER	Output	Alarm output reflecting if the device is in a holdover state. LVCMOS/LVTTL interface levels. 0 = Device is locked to a valid input reference 1 = Device is not locked to a valid input reference
38	CLK0BAD	Output	Alarm output reflecting the state of CLK0. LVCMOS/LVTTL interface levels. 0 = Input Clock 0 is switching within specifications 1 = Input Clock 0 is out of specification
39	CLK1BAD	Output	Alarm output reflecting the state of CLK1. LVCMOS/LVTTL interface levels. 0 = Input Clock 1 is switching within specifications 1 = Input Clock 1 is out of specification
40	XTALBAD	Output	Alarm output reflecting the state of XTAL. LVCMOS/LVTTL interface levels. 0 = crystal is switching within specifications 1 = crystal is out of specification

NOTE: *Pullup and Pulldown* refer to internal input resistors. See Table 2, *Pin Characteristics*, for typical values.

**Table 2. Pin Characteristics**

Symbol	Parameter	Test Conditions	Minimum	Typical	Maximum	Units
C <sub>IN</sub>	Input Capacitance			4		pF
R <sub>PULLUP</sub>	Input Pullup Resistor			51		kΩ
R <sub>PULLDOWN</sub>	Input Pulldown Resistor			51		kΩ
R <sub>OUT</sub>	Output Impedance	Q1		15		Ω
		CLK_ACTIVE, HOLDOVER, XTALBAD, CLK0BAD, CLK1BAD, LOCK_IND		25		Ω

## Functional Description

The ICS849N212I is designed to provide two copies of almost any desired output frequency within its operating range (0.98 - 250MHz) from any input source in the operating range (8kHz - 710MHz). It is capable of synthesizing frequencies from a crystal or crystal oscillator source. The output frequency is generated regardless of the relationship to the input frequency. The output frequency will be exactly the required frequency in most cases. In most others, it will only differ from the desired frequency by a few ppb. IDT configuration software will indicate the frequency error, if any. The ICS849N212I can translate the desired output frequency from one of two input clocks. Again, no relationship is required between the input and output frequencies in order to translate to the output clock rate. In this frequency translation mode, a low-bandwidth, jitter attenuation option is available that makes use of an external fixed-frequency crystal or crystal oscillator to translate from a noisy input source. If the input clock is known to be fairly clean or if some modulation on the input needs to be tracked, then the high-bandwidth frequency translation mode can be used, without the need for the external crystal.

The input clock references and crystal input are monitored continuously and appropriate alarm outputs are raised both as register bits and hard-wired pins in the event of any out-of-specification conditions arising. Clock switching is supported in manual, revertive & non-revertive modes.

The ICS849N212I has two factory-programmed configurations that may be chosen from as the default operating state after reset. This is intended to allow the same device to be used in two different applications without any need for access to the I<sup>2</sup>C registers. These defaults may be over-written by I<sup>2</sup>C register access at any time, but those over-written settings will be lost on power-down. Please contact IDT if a specific set of power-up default settings is desired.

## Configuration Selection

The ICS849N212I comes with two factory-programmed default configurations. When the device comes out of power-up reset the selected configuration is loaded into operating registers. The ICS849N212I uses the state of the CONFIG pin or CONFIG register bit (controlled by the CFG\_PIN\_REG bit) to determine which configuration is active. When the output frequency is changed either via the CONFIG pin or via internal registers, the output behavior may not be predictable during the register writing and output settling periods. Devices sensitive to glitches or runt pulses may have to be reset once reconfiguration is complete.

Once the device is out of reset, the contents of the operating registers can be modified by write access from the I<sup>2</sup>C serial port. Users that have a custom configuration programmed may not require I<sup>2</sup>C access.

It is expected that the ICS849N212I will be used almost exclusively in a mode where the selected configuration will be used from device power-up without any changes during operation. For example, the

device may be designed into a communications line card that supports different I/O modules such as a standard OC-3 module running at 155.52MHz or a (255/237) FEC rate OC-3 module running at 167.332MHz. The different I/O modules would result in a different level on the CONFIG pin which would select different divider ratios within the ICS849N212I for the two different card configurations. Access via I<sup>2</sup>C would not be necessary for operation using either of the internal configurations.

## Operating Modes

The ICS849N212I has three operating modes which are set by the MODE\_SEL[1:0] bits. There are two frequency translator modes - low bandwidth and high bandwidth and a frequency synthesizer mode. The device will operate in the same mode regardless of which configuration is active.

Please make use of IDT-provided configuration applications to determine the best operating settings for the desired configurations of the device.

## Output Dividers & Supported Output Frequencies

In all 3 operating modes, the output stage behaves the same way, but different operating frequencies can be specified in the two configurations.

The internal VCO is capable of operating in a range anywhere from 1.995GHz - 2.6GHz. It is necessary to choose an integer multiplier of the desired output frequency that results in a VCO operating frequency within that range. The output divider stage N[10:0] is limited to selection of even integers from 10 to 2046. Please refer to Table 3 for the values of N applicable to the desired output frequency.

**Table 3. Output Divider Settings & Frequency Ranges**

Register Setting	Frequency Divider	Minimum f <sub>OUT</sub> (MHz)	Maximum f <sub>OUT</sub> (MHz)
Nn[10:0]	N	(MHz)	(MHz)
0000000000 - 0000000100x	2 - 8	Not Supported	
0000000101x	10	199.5	260 (Note 1)
0000000110x	12	166.3	216.7
0000000111x	14	142.5	185.7
0000001000x	16	124.7	162.5
0000001001x	18	110.8	144.4
...	Even N	1995 / N	2600 / N
1111111111x	2046	0.98	1.27

Note 1: using a divider setting of N=0x00A or 0x00B with a high VCO frequency can result in the CMOS output running faster than its 250MHz maximum operating frequency.

### Frequency Synthesizer Mode

This mode of operation allows an arbitrary output frequency to be generated from a fundamental mode crystal input. As can be seen from the block diagram in Figure 1, only the upper feedback loop is used in this mode of operation.

The upper feedback loop supports a delta-sigma fractional feedback divider. This allows the VCO operating frequency to be a non-integer multiple of the crystal frequency. By using an integer multiple only, lower phase noise jitter on the output can be achieved, however the use of the delta-sigma divider logic will provide excellent performance on the output if a fractional divisor is used.

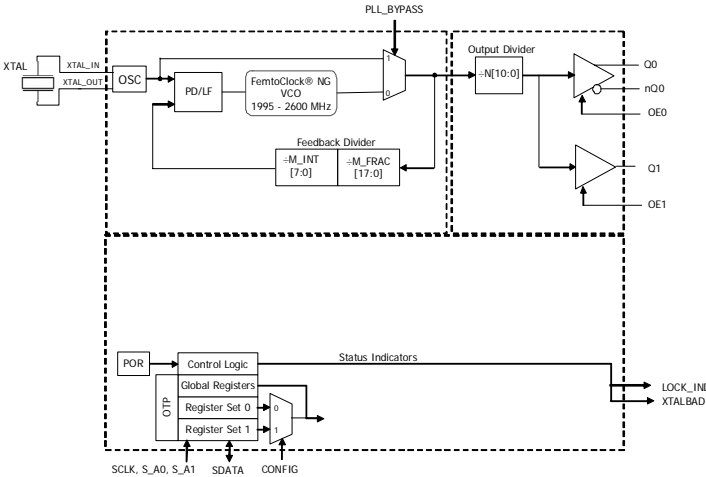

Figure 1. Frequency Synthesizer Mode Block Diagram

### High-Bandwidth Frequency Translator Mode

This mode of operation is used to translate one of two input clocks of the same nominal frequency into an output frequency with little jitter attenuation. As can be seen from the block diagram in Figure 2, similarly to the Frequency Synthesizer mode, only the upper feedback loop is used.

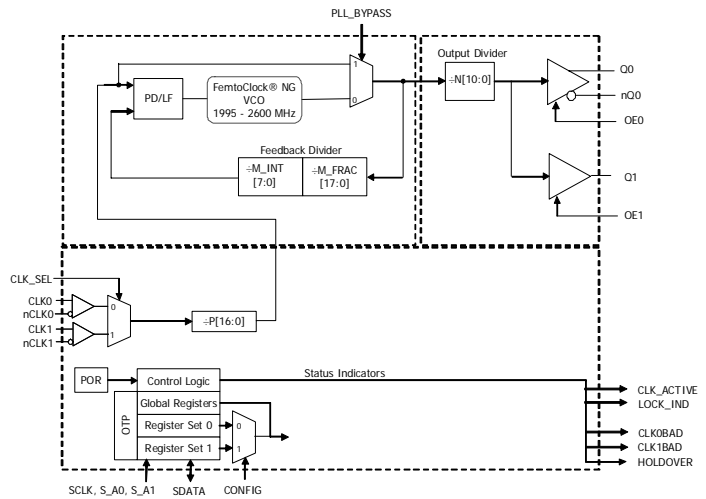

Figure 2. High Bandwidth Frequency Translator Mode Block Diagram

The input reference frequency range is now extended up to 710MHz. A pre-divider stage P is needed to keep the operating frequencies at the phase detector within limits.

### Low-Bandwidth Frequency Translator Mode

As can be seen from the block diagram in Figure 3, this mode involves two PLL loops. The lower loop with the large integer dividers is the low bandwidth loop and it sets the output-to-input frequency translation ratio. This loop drives the upper DCXO loop (digitally controlled crystal oscillator) via an analog-digital converter.

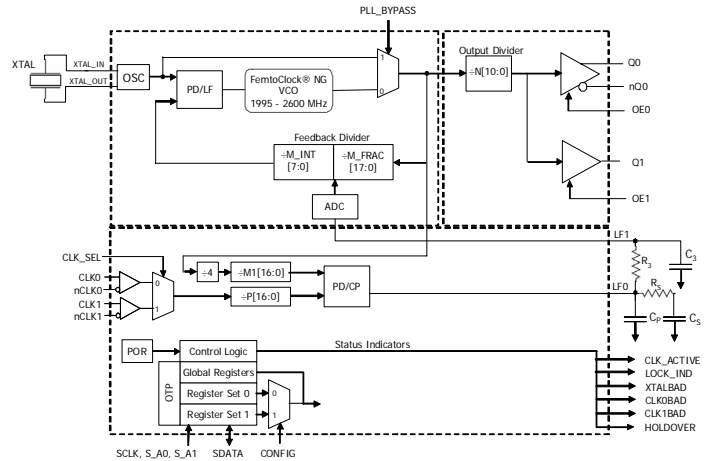

Figure 3. Low Bandwidth Frequency Translator Mode Block Diagram

The phase detector of the lower loop is designed to work with frequencies in the 8kHz - 16kHz range. The pre-divider stage is used to scale down the input frequency by an integer value to achieve a frequency in this range. By dividing down the feedback VCO operating frequency by the integer divider M1[18:0] to as close as possible to the same frequency, very accurate output frequency translations can be achieved.

### Alarm Conditions & Status Bits

The ICS849N212I monitors a number of conditions and reports their status via both output pins and register bits. All alarms will behave as indicated below in all modes of operation, but some of the conditions monitored have no valid meaning in some operating modes. For example, the status of CLK0BAD, CLK1BAD and CLK\_ACTIVE are not relevant in Frequency Synthesizer mode. The outputs will still be active and it is left to the user to determine which to monitor and how to respond to them based on the known operating mode.

CLK\_ACTIVE - indicates which input clock reference is being used to derive the output frequency.

LOCK\_IND - This status is asserted on the pin & register bit when the PLL is locked to the appropriate input reference for the chosen mode of operation. The status bit will not assert until frequency lock has been achieved, but will de-assert once lock is lost.

XTALBAD - indicates if valid edges are being received on the crystal input. Detection is performed by comparing the input to the feedback signal at the upper loop's Phase / Frequency Detector (PFD). If three edges are received on the feedback without an edge on the crystal input, the XTALBAD alarm is asserted on the pin & register bit. Once an edge is detected on the crystal input, the alarm is immediately deasserted.



**CLK0BAD** - indicates if valid edges are being received on the CLK0 reference input. Detection is performed by comparing the input to the feedback signal at the appropriate Phase / Frequency Detector (PFD). When operating in high-bandwidth mode, the feedback at the upper PFD is used. In low-bandwidth mode, the feedback at the lower PFD is used. If three edges are received on the feedback without an edge on the divided down ( $\div P$ ) CLK0 reference input, the CLK0BAD alarm is asserted on the pin & register bit. Once an edge is detected on the CLK0 reference input, the alarm is deasserted.

**CLK1BAD** - indicates if valid edges are being received on the CLK1 reference input. Behavior is as indicated for the CLK0BAD alarm, but with the CLK1 input being monitored and the CLK1BAD output pin & register bits being affected.

**HOLDOVER** - indicates that the device is not locked to a valid input reference clock. This can occur in Manual switchover mode if the selected reference input has gone bad, even if the other reference input is still good. In automatic mode, this will only assert if both input references are bad.

## Input Reference Selection and Switching

When operating in Frequency Synthesizer mode, the CLK0 and CLK1 inputs are not used and the contents of this section do not apply. Except as noted below, when operating in either High or Low Bandwidth Frequency Translator mode, the contents of this section apply equally when in either of those modes.

Both input references CLK0 and CLK1 must be the same nominal frequency. These may be driven by any type of clock source, including crystal oscillator modules. A difference in frequency may cause the PLL to lose lock when switching between input references. Please contact IDT for the exact limits for your situation.

The global control bits AUTO\_MAN[1:0] dictate the order of priority and switching mode to be used between the CLK0 and CLK1 inputs.

### Manual Switching Mode

When the AUTO\_MAN[1:0] field is set to Manual via Pin, then the ICS849N212I will use the CLK\_SEL input pin to determine which input to use as a reference. Similarly, if set to Manual via Register, then the device will use the CLK\_SEL register bit to determine the input reference. In either case, the PLL will lock to the selected reference if there is a valid clock present on that input.

If there is not a valid clock present on the selected input, the ICS849N212I will go into holdover (Low Bandwidth Frequency Translator mode) or free-run (High Bandwidth Frequency Translator mode) state. In either case, the HOLDOVER alarm will be raised. This will occur even if there is a valid clock on the non-selected reference input.

The device will recover from holdover / free-run state once a valid clock is re-established on the selected reference input.

The ICS849N212I will only switch input references on command from the user. The user must either change the CLK\_SEL register bit (if in Manual via Register) or CLK\_SEL input pin (if in Manual via Pin).

### Automatic Switching Mode

When the AUTO\_MAN[1:0] field is set to either of the automatic selection modes (Revertive or Non-Revertive), the ICS849N212I determines which input reference it prefers / starts from by the state of the CLK\_SEL register bit only. The CLK\_SEL input pin is not used in either Automatic switching mode.

When starting from an unlocked condition, the device will lock to the input reference indicated by the CLK\_SEL register bit. It will not pay attention to the non-selected input reference until a locked state has been achieved. This is necessary to prevent 'hunting' behavior during the locking phase.

Once the ICS849N212I has achieved a stable lock, it will remain locked to the preferred input reference as long as there is a valid clock on it. If at some point, that clock fails, then the device will automatically switch to the other input reference as long as there is a valid clock there. If there is not a valid clock on either input reference, the ICS849N212I will go into holdover (Low Bandwidth Frequency Translator mode) or free-run (High Bandwidth Frequency Translator mode) state. In either case, the HOLDOVER alarm will be raised.

The device will recover from holdover / free-run state once a valid clock is re-established on either reference input. If clocks are valid on both input references, the device will choose the reference indicated by the CLK\_SEL register bit.

If running from the non-preferred input reference and a valid clock returns, there is a difference in behavior between Revertive and Non-revertive modes. In Revertive mode, the device will switch back to the reference indicated by the CLK\_SEL register bit even if there is still a valid clock on the non-preferred reference input. In Non-revertive mode, the ICS849N212I will not switch back as long as the non-preferred input reference still has a valid clock on it.

### Switchover Behavior of the PLL

Even though the two input references have the same nominal frequency, there may be minor differences in frequency and potentially large differences in phase between them. The ICS849N212I will adjust its output to the new input reference. It will use Phase Slope Limiting to adjust the output phase at a fixed maximum rate until the output phase and frequency are now aligned to the new input reference. Phase will always be adjusted by extending the clock period of the output so that no unacceptably short clock periods are generated on the output ICS849N212I.

### Holdover / Free-run Behavior

When both input references have failed (Automatic mode) or the selected input has failed (Manual mode), the ICS849N212I will enter holdover (Low Bandwidth Frequency Translator mode) or free-run (High Bandwidth Frequency Translator mode) state. In both cases, once both input references are lost, the PLL will stop making adjustments to the output phase.

If operating in Low Bandwidth Frequency Translation mode, the PLL will continue to reference itself to the local oscillator and will hold its output phase and frequency in relation to that source. Output stability is determined by the stability of the local oscillator in this case.

However, if operating in High Bandwidth Frequency Translation mode, the PLL no longer has any frequency reference to use and output stability is now determined by the stability of the internal VCO.

If the device is programmed to perform Manual switching, once the selected input reference recovers, the ICS849N212I will switch back to that input reference. If programmed for either Automatic mode, the device will switch back to whichever input reference has a valid clock first.

The switchover that results from returning from holdover or free-run is handled in the same way as a switch between two valid input references as described in the previous section.

### Output Configuration

The two outputs of the ICS849N212I both provide the same clock frequency. Both must operate from the same output voltage level of 3.3V or 2.5V, although this output voltage may be less than or equal to the core voltage (3.3V or 2.5V) the rest of the device is operating from. The output voltage level used on the two outputs is supplied on the V<sub>CCO</sub> pin.

The Q0 output is selectable as LVDS or LVPECL output type via the Q0\_TYPEm register bits. This selection bit is provided in each configuration to allow different output type settings under each configuration.

The Q1 output is always an LVCMOS output.

The two outputs can be enabled individually also via both register control bits and input pins. When both the OEn register bit and OEN

pin are enabled, then the appropriate output is enabled. The OEn register bits default to enabled so that by default the outputs can be directly controlled by the input pins. Similarly, the input pins are provisioned with weak pull-ups so that if they are left unconnected, the output state can be directly controlled by the register bits. When the differential output is in the disabled state, it will show a high impedance condition.

### Serial Interface Configuration Description

The ICS849N212I has an I<sup>2</sup>C-compatible configuration interface to access any of the internal registers (Table 4D) for frequency and PLL parameter programming. The ICS849N212I acts as a slave device on the I<sup>2</sup>C bus and has the address 0b11011xx, where xx is set by the values on the S\_A0 & S\_A1 pins (see Table 4A for details). The interface accepts byte-oriented block write and block read operations. An address byte (P) specifies the register address (Table 4D) as the byte position of the first register to write or read. Data bytes (registers) are accessed in sequential order from the lowest to the highest byte (most significant bit first, see table 4B, 4C). Read and write block transfers can be stopped after any complete byte transfer. It is recommended to terminate I<sup>2</sup>C the read or write transfer after accessing byte #23.

For full electrical I<sup>2</sup>C compliance, it is recommended to use external pull-up resistors for SDATA and SCLK. The internal pull-up resistors have a size of 50kΩ typical.

Note: if a different device slave address is desired, please contact IDT.

**Table 4A. I<sup>2</sup>C Device Slave Address**

1	1	0	1	1	S_A1	S_A0	R/W
---	---	---	---	---	------	------	-----

**Table 4B. Block Write Operation**

Bit	1	2:8	9	10	11:18	19	20:27	28	29-36	37	...	...	...
Description	START	Slave Address	W (0)	ACK	Address Byte (P)	ACK	Data Byte (P)	ACK	Data Byte (P+1)	ACK	Data Byte ...	ACK	STOP
Length (bits)	1	7	1	1	8	1	8	1	8	1	8	1	1

**Table 4C. Block Read Operation**

Bit	1	2:8	9	10	11:18	19	20	21:27	28	29	30:37	38	39-46	47	...	...	...
Description	START	Slave Address	W (0)	ACK	Address Byte (P)	ACK	Repeated START	Slave Address	R (1)	ACK	Data Byte (P)	ACK	DataByte (P+1)	ACK	Data Byte ...	ACK	STOP
Length (bits)	1	7	1	1	8	1	1	7	1	1	8	1	8	1	8	1	1



## Register Descriptions

Please consult IDT for configuration software and/or programming guides to assist in selection of optimal register settings for the desired configurations.

**Table 4D. I<sup>2</sup>C Register Map**

Register	Binary Register Address	Register Bit							
		D7	D6	D5	D4	D3	D2	D1	D0
0	00000	MFRAC0[17]	MFRAC0[16]	MFRAC0[15]	MFRAC0[14]	MFRAC0[13]	MFRAC0[12]	MFRAC0[11]	MFRAC0[10]
1	00001	MFRAC1[17]	MFRAC1[16]	MFRAC1[15]	MFRAC1[14]	MFRAC1[13]	MFRAC1[12]	MFRAC1[11]	MFRAC1[10]
2	00010	MFRAC0[9]	MFRAC0[8]	MFRAC0[7]	MFRAC0[6]	MFRAC0[5]	MFRAC0[4]	MFRAC0[3]	MFRAC0[2]
3	00011	MFRAC1[9]	MFRAC1[8]	MFRAC1[7]	MFRAC1[6]	MFRAC1[5]	MFRAC1[4]	MFRAC1[3]	MFRAC1[2]
4	00100	MFRAC0[1]	MFRAC0[0]	MINT0[7]	MINT0[6]	MINT0[5]	MINT0[4]	MINT0[3]	MINT0[2]
5	00101	MFRAC1[1]	MFRAC1[0]	MINT1[7]	MINT1[6]	MINT1[5]	MINT1[4]	MINT1[3]	MINT1[2]
6	00110	MINT0[1]	MINT0[0]	P0[16]	P0[15]	P0[14]	P0[13]	P0[12]	P0[11]
7	00111	MINT1[1]	MINT1[0]	P1[16]	P1[15]	P1[14]	P1[13]	P1[12]	P1[11]
8	01000	P0[10]	P0[9]	P0[8]	P0[7]	P0[6]	P0[5]	P0[4]	P0[3]
9	01001	P1[10]	P1[9]	P1[8]	P1[7]	P1[6]	P1[5]	P1[4]	P1[3]
10	01010	P0[2]	P0[1]	P0[0]	M1_0[16]	M1_0[15]	M1_0[14]	M1_0[13]	M1_0[12]
11	01011	P1[2]	P1[1]	P1[0]	M1_1[16]	M1_1[15]	M1_1[14]	M1_1[13]	M1_1[12]
12	01100	M1_0[11]	M1_0[10]	M1_0[9]	M1_0[8]	M1_0[7]	M1_0[6]	M1_0[5]	M1_0[4]
13	01101	M1_1[11]	M1_1[10]	M1_1[9]	M1_1[8]	M1_1[7]	M1_1[6]	M1_1[5]	M1_1[4]
14	01110	M1_0[3]	M1_0[2]	M1_0[1]	M1_0[0]	N0[10]	N0[9]	N0[8]	N0[7]
15	01111	M1_1[3]	M1_1[2]	M1_1[1]	M1_1[0]	N1[10]	N1[9]	N1[8]	N1[7]
16	10000	N0[6]	N0[5]	N0[4]	N0[3]	N0[2]	N0[1]	N0[0]	BW0[6]
17	10001	N1[6]	N1[5]	N1[4]	N1[3]	N1[2]	N1[1]	N1[0]	BW1[6]
18	10010	BW0[5]	BW0[4]	BW0[3]	BW0[2]	BW0[1]	BW0[0]	Rsvd	Q0_TYPE0
19	10011	BW1[5]	BW1[4]	BW1[3]	BW1[2]	BW1[1]	BW1[0]	Rsvd	Q0_TYPE1
20	10100	MODE_SEL[1]	MODE_SEL[0]	CONFIG	CFG_PIN_REG	OE1	OE0	Rsvd	Rsvd
21	10101	CLK_SEL	AUTO_MAN[1]	AUTO_MAN[0]	0	ADC_RATE[1]	ADC_RATE[0]	LCK_WIN[1]	LCK_WIN[0]
22	10110	1	0	1	0	0	0	0	0
23	10111	CLK_ACTIVE	HOLDOVER	CLK1BAD	CLK0BAD	XTAL_BAD	LOCK_IND	Rsvd	Rsvd

### Register Bit Color Key

Configuration 0 Specific Bits
Configuration 1 Specific Bits
Global Control & Status Bits

The register bits described in Table 4E are duplicated, with one set applying for Configuration 0 and the other for Configuration 1. The functions of the bits are identical, but only apply when the

configuration they apply to is enabled. Replace the lowercase n in the bit field description with 0 or 1 to find the field's location in the bitmap in Table 4D.

**Table 4E. Configuration-Specific Control Bits**

Register Bits	Function
Q0_TYPE <sub>n</sub>	Determines the output type for output pair Q0, nQ0 for Configuration n. 0 = LVPECL 1 = LVDS
P <sub>n</sub> [16:0]	Reference Pre-Divider for Configuration n.
M1_ <sub>n</sub> [16:0]	Integer Feedback Divider in Lower Feedback Loop for Configuration n.
M_INT <sub>n</sub> [7:0]	Feedback Divider, Integer Value in Upper Feedback Loop for Configuration n.
M_FRAC <sub>n</sub> [17:0]	Feedback Divider, Fractional Value in Upper Feedback Loop for Configuration n.
N <sub>n</sub> [10:0]	Output Divider for Configuration n.
BW <sub>n</sub> [6:0]	Internal Operation Settings for Configuration n. Please use IDT ICS849N212I Configuration Software to determine the correct settings for these bits for the specific configuration. Alternatively, please consult with IDT directly for further information on the functions of these bits. The function of these bits is explained in Tables 4J and 4K.

**Table 4F. Global Control Bits**

Register Bits	Function
MODE_SEL[1:0]	PLL Mode Select 00 = Low Bandwidth Frequency Translator 01 = Frequency Synthesizer 10 = High Bandwidth Frequency Translator 11 = High Bandwidth Frequency Translator
CFG_PIN_REG	Configuration Control. Selects whether the configuration selection function is under pin or register control. 0 = Pin Control 1 = Register Control
CONFIG	Configuration Selection. Selects whether the device uses the register configuration set 0 or 1. This bit only has an effect when the CFG_PIN_REG bit is set to 1 to enable register control.
OE0	Output Enable Control for Output 0. Both this register bit and the corresponding Output Enable pin OE0 must be asserted to enable the Q0, nQ0 output. 0 = Output Q0, nQ0 disabled 1 = Output Q0, nQ0 under control of the OE0 pin
OE1	Output Enable Control for Output 1. Both this register bit and the corresponding Output Enable pin OE1 must be asserted to enable the Q1 output. 0 = Output Q1 disabled 1 = Output Q1 under control of the OE1 pin
Rsvd	Reserved bits - user should write a '0' to these bit positions if a write to these registers is needed
AUTO_MAN[1:0]	Selects how input clock selection is performed. 00 = Manual Selection via pin only 01 = Automatic, non-revertive 10 = Automatic, revertive 11 = Manual Selection via register only

CLK_SEL	In manual clock selection via register mode, this bit will command which input clock is selected. In the automatic modes, this indicates the primary clock input. In manual selection via pin mode, this bit has no effect. 0 = CLK0 1 = CLK1
ADC_RATE[1:0]	Sets the ADC sampling rate in Low-Bandwidth Mode as a fraction of the crystal input frequency. 00 = Crystal Frequency / 16 01 = Crystal Frequency / 8 10 = Crystal Frequency / 4 (recommended) 11 = Crystal Frequency / 2
LCK_WIN[1:0]	Sets the width of the window in which a new reference edge must fall relative to the feedback edge: 00 = 2usec (recommended), 01 = 4usec, 10 = 8usec, 11 = 16usec

**Table 4G. Global Status Bits**

Register Bits	Function
CLK0BAD	Status Bit for input clock 0. This function is mirrored in the CLK0BAD pin. 0 = input 0 good 1 = input 0 bad. Self clears when input clock returns to good status
CLK1BAD	Status Bit for input clock 1. This function is mirrored in the CLK1BAD pin. 0 = input 0 good 1 = input 0 bad. Self clears when input clock returns to good status
XTALBAD	Status Bit. This function is mirrored on the XTALBAD pin. 0 = crystal input good 1 = crystal input bad. Self-clears when the XTAL clock returns to good status
LOCK_IND	Status bit. This function is mirrored on the LOCK_IND pin. 0 = PLL unlocked 1 = PLL locked
HOLDOVER	Status Bit. This function is mirrored on the HOLDOVER pin. 0 = Input to phase detector is within specifications and device is tracking to it 1 = Phase detector input not within specifications and DCXO is frozen at last value
CLK_ACTIVE	Status Bit. Indicates which input clock is active. Automatically updates during fail-over switching. Status also indicated on CLK_ACTIVE pin.

**Table 4J. BW[6:0] Bits**

Mode	BW[6]	BW[5]	BW[4]	BW[3]	BW[2]	BW[1]	BW[0]
Synthesizer Mode	PLL2_LF[1]	PLL2_LF[0]	DSM_ORD	DSM_EN	PLL2_CP[1]	PLL2_CP[0]	PLL2_LOW_ICP
High-Bandwidth Mode	PLL2_LF[1]	PLL2_LF[0]	DSM_ORD	DSM_EN	PLL2_CP[1]	PLL2_CP[0]	PLL2_LOW_ICP
Low-Bandwidth Mode	ADC_GAIN[3]	ADC_GAIN[2]	ADC_GAIN[1]	ADC_GAIN[0]	PLL1_CP[1]	PLL1_CP[0]	PLL2_LOW_ICP

**Table 4K. Functions of Fields in BW[6:0]**

Register Bits	Function
PLL2_LF[1:0]	Sets loop filter values for upper loop PLL in Frequency Synthesizer & High-Bandwidth modes. Defaults to setting of 00 when in Low Bandwidth Mode. See Table 4L for settings.
DSM_ORD	Sets Delta-Sigma Modulation to 2nd (0) or 3rd order (1) operation.
DSM_EN	Enables Delta-Sigma Modulator. 0 = Disabled - feedback in integer mode only 1 = Enabled - feedback in fractional mode
PLL2_CP[1:0]	Upper loop PLL charge pump current settings: 00 = 173 $\mu$ A (defaults to this setting in Low Bandwidth Mode) 01 = 346 $\mu$ A 10 = 692 $\mu$ A 11 = reserved
PLL2_LOW_ICP	Reduces Charge Pump current by 1/3 <sup>RD</sup> to reduce bandwidth variations resulting from higher feedback register settings or high VCO operating frequency (>2.4GHz).
ADC_GAIN[3:0]	Gain setting for ADC in Low Bandwidth Mode.
PLL1_CP[1:0]	Lower loop PLL charge pump current settings (lower loop is only used in Low Bandwidth Mode): 00 = 800 $\mu$ A 01 = 400 $\mu$ A 10 = 200 $\mu$ A 11 = 100 $\mu$ A

**Table 4L. Upper Loop (PLL2) Bandwidth Settings**

Desired Bandwidth	PLL2_CP	PLL2ICP	PLL2_LF
<b>Frequency Synthesizer Mode</b>			
200kHz	00	1	00
400kHz	01	1	01
800kHz	10	1	10
2MHz	10	1	11
<b>High Bandwidth Frequency Translator Mode</b>			
200kHz	00	1	00
400kHz	01	1	01
800kHz	10	1	10
4MHz	10	0	11
<b>Low Bandwidth Frequency Translator Mode</b>			
200kHz	00		00

NOTE: To achieve 4MHz bandwidth, reference to the phase detector should be 80MHz.

## Absolute Maximum Ratings

NOTE: Stresses beyond those listed under *Absolute Maximum Ratings* may cause permanent damage to the device. These ratings are stress specifications only. Functional operation of product at these conditions or any conditions beyond those listed in the *DC Characteristics* or *AC Characteristics* is not implied. Exposure to absolute maximum rating conditions for extended periods may affect product reliability.

Item	Rating
Supply Voltage, $V_{CC}$	3.63V
Inputs, $V_I$ XTAL_IN Other Input	0V to 2V -0.5V to $V_{CC} + 0.5V$
Outputs, $V_O$ (LVCMOS)	-0.5V to $V_{CCO} + 0.5V$
Outputs, $I_O$ (LVPECL) Continuous Current Surge Current	50mA 100mA
Outputs, $I_O$ (LVDS) Continuous Current Surge Current	10mA 15mA
Package Thermal Impedance, $\theta_{JA}$	32.4°C/W (0 mps)
Storage Temperature, $T_{STG}$	-65°C to 150°C

## DC Electrical Characteristics

**Table 5A. LVPECL Power Supply DC Characteristics,  $V_{CC} = V_{CCO} = 3.3V \pm 5\%$ ,  $V_{EE} = 0V$ ,  $T_A = -40^\circ C$  to  $85^\circ C$**

Symbol	Parameter	Test Conditions	Minimum	Typical	Maximum	Units
$V_{CC}$	Core Supply Voltage		3.135	3.3	3.465	V
$V_{CCA}$	Analog Supply Voltage		$V_{CC} - 0.30$	3.3	$V_{CC}$	V
$V_{CCO}$	Output Supply Voltage		3.135	3.3	3.465	V
$I_{EE}$	Power Supply Current	Outputs Unloaded			320	mA
$I_{CCA}$	Analog Supply Current	Outputs Unloaded			30	mA

**Table 5B. LVPECL Power Supply DC Characteristics,  $V_{CC} = 3.3V \pm 5\%$ ,  $V_{CCO} = 2.5V \pm 5\%$ ,  $V_{EE} = 0V$ ,  $T_A = -40^\circ C$  to  $85^\circ C$**

Symbol	Parameter	Test Conditions	Minimum	Typical	Maximum	Units
$V_{CC}$	Core Supply Voltage		3.135	3.3	3.465	V
$V_{CCA}$	Analog Supply Voltage		$V_{CC} - 0.30$	3.3	$V_{CC}$	V
$V_{CCO}$	Output Supply Voltage		2.375	2.5	2.625	V
$I_{EE}$	Power Supply Current	Outputs Unloaded			319	mA
$I_{CCA}$	Analog Supply Current	Outputs Unloaded			30	mA

NOTE: Table only applies when output Q0, nQ0 is in LVPECL mode.

**Table 5C. LVPECL Power Supply DC Characteristics,  $V_{CC} = V_{CCO} = 2.5V \pm 5\%$ ,  $V_{EE} = 0V$ ,  $T_A = -40^\circ C$  to  $85^\circ C$** 

Symbol	Parameter	Test Conditions	Minimum	Typical	Maximum	Units
$V_{CC}$	Core Supply Voltage		2.375	2.5	2.625	V
$V_{CCA}$	Analog Supply Voltage		$V_{CC} - 0.26$	2.5	$V_{CC}$	V
$V_{CCO}$	Output Supply Voltage		2.375	2.5	2.625	V
$I_{EE}$	Power Supply Current	Outputs Unloaded			304	mA
$I_{CCA}$	Analog Supply Current	Outputs Unloaded			26	mA

**Table 5D. LVDS Power Supply DC Characteristics,  $V_{CC} = V_{CCO} = 3.3V \pm 5\%$ ,  $V_{EE} = 0V$ ,  $T_A = -40^\circ C$  to  $85^\circ C$** 

Symbol	Parameter	Test Conditions	Minimum	Typical	Maximum	Units
$V_{CC}$	Core Supply Voltage		3.135	3.3	3.465	V
$V_{CCA}$	Analog Supply Voltage		$V_{CC} - 0.30$	3.3	$V_{CC}$	V
$V_{CCO}$	Output Supply Voltage		3.135	3.3	3.465	V
$I_{CC}$	Power Supply Current	Outputs Unloaded			280	mA
$I_{CCA}$	Analog Supply Current	Outputs Unloaded			30	mA
$I_{CCO}$	Output Supply Current	Outputs Unloaded			40	mA

**Table 5E. LVDS Power Supply DC Characteristics,  $V_{CC} = V_{CCO} = 2.5V \pm 5\%$ ,  $V_{EE} = 0V$ ,  $T_A = -40^\circ C$  to  $85^\circ C$** 

Symbol	Parameter	Test Conditions	Minimum	Typical	Maximum	Units
$V_{CC}$	Core Supply Voltage		2.375	2.5	2.625	V
$V_{CCA}$	Analog Supply Voltage		$V_{CC} - 0.26$	2.5	$V_{CC}$	V
$V_{CCO}$	Output Supply Voltage		2.375	2.5	2.625	V
$I_{CC}$	Power Supply Current	Outputs Unloaded			275	mA
$I_{CCA}$	Analog Supply Current	Outputs Unloaded			26	mA
$I_{CCO}$	Output Supply Current	Outputs Unloaded			40	mA



**Table 5F. LVCMOS/LVTTL DC Characteristics,  $T_A = -40^\circ\text{C}$  to  $85^\circ\text{C}$** 

Symbol	Parameter		Test Conditions	Minimum	Typical	Maximum	Units
$V_{IH}$	Input High Voltage		$V_{CC} = 3.3\text{V}$	2		$V_{CC} + 0.3$	V
			$V_{CC} = 2.5\text{V}$	1.7		$V_{CC} + 0.3$	V
$V_{IL}$	Input Low Voltage		$V_{CC} = 3.3\text{V}$	-0.3		0.8	V
			$V_{CC} = 2.5\text{V}$	-0.3		0.7	V
$I_{IH}$	Input High Current	CLK_SEL, CONFIG, PLL_BYPASS, S_A[0:1]	$V_{CC} = V_{IN} = 3.465\text{V}$ or $2.625\text{V}$			150	$\mu\text{A}$
		OE0, OE1, SCLK, SDATA	$V_{CC} = V_{IN} = 3.465\text{V}$ or $2.625\text{V}$			5	$\mu\text{A}$
$I_{IL}$	Input Low Current	CLK_SEL, CONFIG, PLL_BYPASS, S_A[0:1]	$V_{CC} = 3.465\text{V}$ or $2.625\text{V}$ , $V_{IN} = 0\text{V}$	-5			$\mu\text{A}$
		OE0, OE1, SCLK, SDATA	$V_{CC} = 3.465\text{V}$ or $2.625\text{V}$ , $V_{IN} = 0\text{V}$	-150			$\mu\text{A}$
$V_{OH}$	Output High Voltage	HOLDOVER, CLK_ACTIVE, SDATA, LOCK_IND, XTALBAD, CLK0BAD, CLK1BAD	$V_{CCO} = 3.465\text{V}$ , $I_{OH} = -8\text{mA}$	2.6			V
			$V_{CCO} = 2.625\text{V}$ , $I_{OH} = -8\text{mA}$	1.8			V
		Q1	$V_{CCO} = 3.465\text{V}$ , $I_{OH} = -12\text{mA}$	2.6			V
			$V_{CCO} = 2.625\text{V}$ , $I_{OH} = -12\text{mA}$	1.8			V
$V_{OL}$	Output Low Voltage	HOLDOVER, CLK_ACTIVE, SDATA, LOCK_IND, XTALBAD, CLK0BAD, CLK1BAD	$V_{CCO} = 3.465\text{V}$ or $2.625\text{V}$ , $I_{OL} = 8\text{mA}$			0.5	V
			Q1	$V_{CCO} = 3.465\text{V}$ or $2.625\text{V}$ , $I_{OL} = 12\text{mA}$			0.5

**Table 5G. Differential DC Characteristics,  $V_{CC} = V_{CCO} = 3.3\text{V} \pm 5\%$  or  $2.5\text{V} \pm 5\%$ ,  $V_{EE} = 0\text{V}$ ,  $T_A = -40^\circ\text{C}$  to  $85^\circ\text{C}$** 

Symbol	Parameter		Test Conditions	Minimum	Typical	Maximum	Units
$I_{IH}$	Input High Current	CLK0, nCLK0, CLK1, nCLK1	$V_{CC} = V_{IN} = 3.465\text{V}$ or $2.625\text{V}$			150	$\mu\text{A}$
$I_{IL}$	Input Low Current	CLK0, CLK1	$V_{CC} = 3.465\text{V}$ or $2.625\text{V}$ , $V_{IN} = 0\text{V}$	-5			$\mu\text{A}$
		nCLK0, nCLK1	$V_{CC} = 3.465\text{V}$ or $2.625\text{V}$ , $V_{IN} = 0\text{V}$	-150			$\mu\text{A}$
$V_{PP}$	Peak-to-Peak Voltage; NOTE 1			0.15		1.3	V
$V_{CMR}$	Common Mode Input Voltage; NOTE 1, 2			$V_{EE} + 0.5$		$V_{CC} - 1.0$	V

NOTE 1:  $V_{IL}$  should not be less than  $-0.3\text{V}$ .

NOTE 2: Common mode voltage is defined as the crosspoint.

**Table 5H. LVPECL DC Characteristics,  $V_{CC} = V_{CCO} = 3.3\text{V} \pm 5\%$ ,  $V_{EE} = 0\text{V}$ ,  $T_A = -40^\circ\text{C}$  to  $85^\circ\text{C}$** 

Symbol	Parameter	Test Conditions	Minimum	Typical	Maximum	Units
$V_{OH}$	Output High Voltage; NOTE 1		$V_{CCO} - 1.1$		$V_{CCO} - 0.7$	V
$V_{OL}$	Output Low Voltage NOTE 1		$V_{CCO} - 2.0$		$V_{CCO} - 1.5$	V
$V_{SWING}$	Peak-to-Peak Output Voltage Swing		0.6		1.0	V

NOTE 1: Outputs terminated with  $50\Omega$  to  $V_{CCO} - 2\text{V}$ .

**Table 5I. LVPECL DC Characteristics,  $V_{CC} = 3.3V \pm 5\%$  or  $2.5V \pm 5\%$ ,  $V_{CCO} = 2.5V \pm 5\%$ ,  $V_{EE} = 0V$ ,  $T_A = -40^\circ C$  to  $85^\circ C$** 

Symbol	Parameter	Test Conditions	Minimum	Typical	Maximum	Units
$V_{OH}$	Output High Voltage; NOTE 1		$V_{CCO} - 1.1$		$V_{CCO} - 0.8$	V
$V_{OL}$	Output Low Voltage NOTE 1		$V_{CCO} - 2.0$		$V_{CCO} - 1.5$	V
$V_{SWING}$	Peak-to-Peak Output Voltage Swing		0.6		1.0	V

NOTE 1: Outputs terminated with  $50\Omega$  to  $V_{CCO} - 2V$ .

**Table 5J. LVDS DC Characteristics,  $V_{CC} = V_{CCO} = 3.3V \pm 5\%$ ,  $T_A = -40^\circ C$  to  $85^\circ C$** 

Symbol	Parameter	Test Conditions	Minimum	Typical	Maximum	Units
$V_{OD}$	Differential Output Voltage		247		454	mV
$\Delta V_{OD}$	$V_{OD}$ Magnitude Change				50	mV
$V_{OS}$	Offset Voltage		1.125		1.375	V
$\Delta V_{OS}$	$V_{OS}$ Magnitude Change				50	mV

**Table 5K. LVDS DC Characteristics,  $V_{CC} = V_{CCO} = 2.5V \pm 5\%$ ,  $T_A = -40^\circ C$  to  $85^\circ C$** 

Symbol	Parameter	Test Conditions	Minimum	Typical	Maximum	Units
$V_{OD}$	Differential Output Voltage		247		454	mV
$\Delta V_{OD}$	$V_{OD}$ Magnitude Change				50	mV
$V_{OS}$	Offset Voltage		1.125		1.375	V
$\Delta V_{OS}$	$V_{OS}$ Magnitude Change				50	mV

**Table 6. Input Frequency Characteristics,  $V_{CC} = V_{CCO} = 3.3V \pm 5\%$ ,  $T_A = -40^\circ C$  to  $85^\circ C$** 

Symbol	Parameter	Test Conditions	Minimum	Typical	Maximum	Units	
$f_{IN}$	Input Frequency	XTAL_IN, XTAL_OUT NOTE 1	16		40	MHz	
		CLK0, nCLK0, CLK1, nCLK1	High Bandwidth Mode	16		710	MHz
			Low Bandwidth Mode	0.008		710	MHz
		SCLK				5	MHz

NOTE 1: For the input crystal and CLKx, nCLKx frequency range, the M value must be set for the VCO to operate within the 1995MHz to 2600MHz range.

**Table 7. Crystal Characteristics**

Parameter	Test Conditions	Minimum	Typical	Maximum	Units
Mode of Oscillation		Fundamental			
Frequency		16		40	MHz
Equivalent Series Resistance (ESR)				100	$\Omega$
Shunt Capacitance				7	pF
Load Capacitance ( $C_L$ )			12		pF

## AC Electrical Characteristics

**Table 8. AC Characteristics**,  $V_{CC} = V_{CCO} = 3.3V \pm 5\%$  or  $2.5V \pm 5\%$ , or  $V_{CC} = 3.3V \pm 5\%$ ,  $V_{CCO} = 2.5V \pm 5\%$  (LVPECL only),  $V_{EE} = 0V$ ,  $T_A = -40^\circ C$  to  $85^\circ C$

Symbol	Parameter	Test Conditions	Minimum	Typical	Maximum	Units
$f_{OUT}$	Output Frequency		0.98		250	MHz
$f_{jit}(\emptyset)$	RMS Phase Jitter (Random); NOTE 1	LBW Mode (FRACn), 40MHz XTAL, $f_{IN} = 25MHz$ , $f_{OUT} = 125MHz$ , Integration Range: 12kHz – 20MHz		558	674	fs
	RMS Phase Jitter (Random); NOTE 2	HBW Mode (Integer FB), $f_{IN} = 100MHz$ , $f_{OUT} = 125MHz$ , Integration Range: 12kHz – 20MHz		388	594	fs
$f_{jit}$	RMS Period Jitter	LVPECL Output		1.8	3.0	ps
		LVDS Output		4.5	6.5	ps
		LVC MOS Output Q1		1.4	4.5	ps
$f_{jit}(cc)$	Cycle-to-Cycle Jitter; NOTE 3	Frequency Synthesizer Mode			40	ps
		Frequency Translator Mode			35	ps
$t_{sk}(o)$	Output Skew; NOTE 3, 4			1		ns
$t_R / t_F$	Output Rise/Fall Time	LVPECL Output	20% to 80%	60	630	ps
		LVDS Output	20% to 80%	55	650	ps
		LVC MOS Output (Q1)	20% to 80%	100	750	ps
odc	Output Duty Cycle	LVPECL Output		45	55	%
		LVDS Output		45	55	%
		LVC MOS Output Q1		40	60	%
$t_{SET}$	Output Re-configuration Settling Time	from falling edge of the 8th SCLK for a register change		200		ns
		from edge on CONFIG pin		10		ns

NOTE: Electrical parameters are guaranteed over the specified ambient operating temperature range, which is established when the device is mounted in a test socket with maintained transverse airflow greater than 500 lfm. The device will meet specifications after thermal equilibrium has been reached under these conditions.

NOTE 1. RMS Phase Jitter is measured with crystal  $C_L = 12pF$ .

NOTE 2. Measured using a Rohde & Schwarz SMA100 Signal Generator, 9kHz to 6GHz as the input source.

NOTE 3: This parameter is defined in accordance with JEDEC Standard 65.

NOTE 4: Timing relationship between the Q0, nQ0 differential crosspoint and the 50% point of the Q1 single-ended rising edge. Refer to the figure in the *Parameter Measurement Information Section*.

### Typical Phase Noise at 125MHz (HBW Mode)

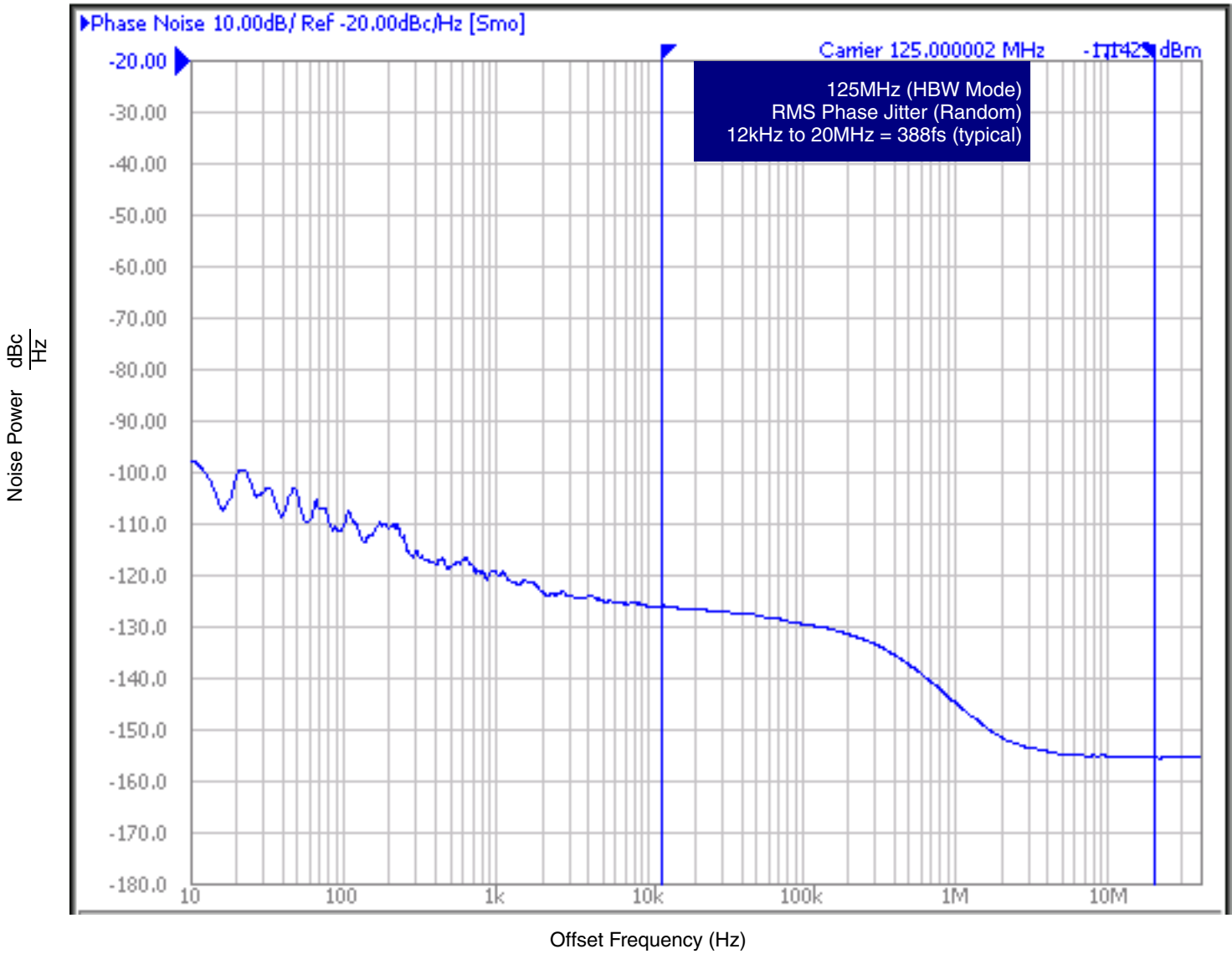

## Parameter Measurement Information

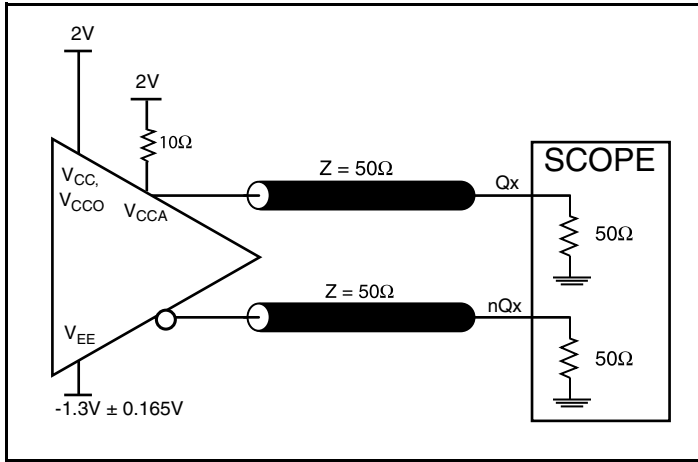

3.3 Core/3.3V LVPECL Output Load Test Circuit

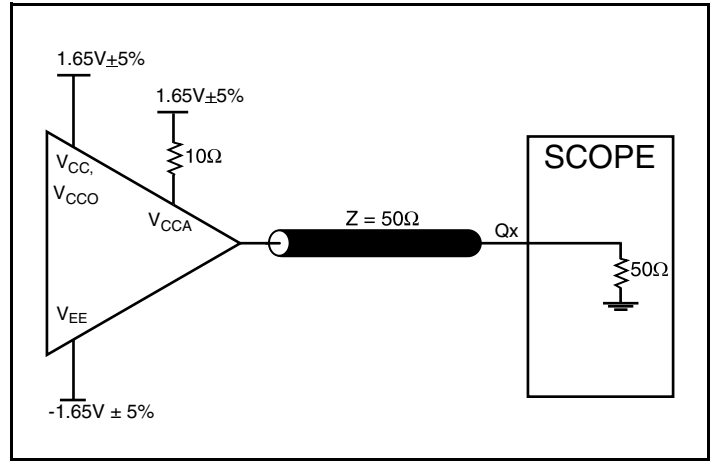

3.3 Core/3.3V LVCMOS Output Load Test Circuit

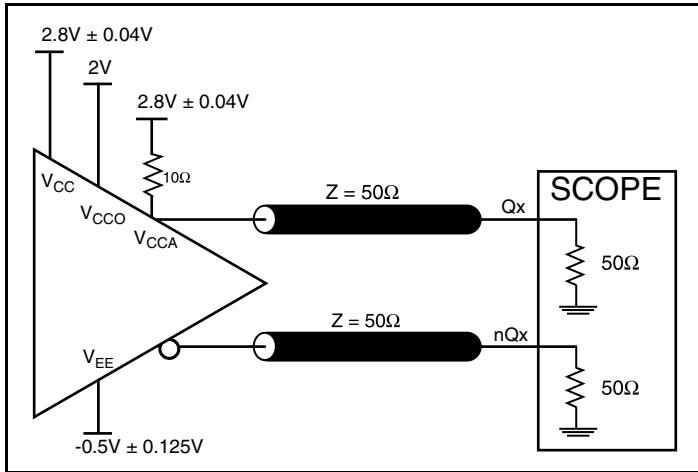

3.3 Core/2.5V LVPECL Output Load Test Circuit

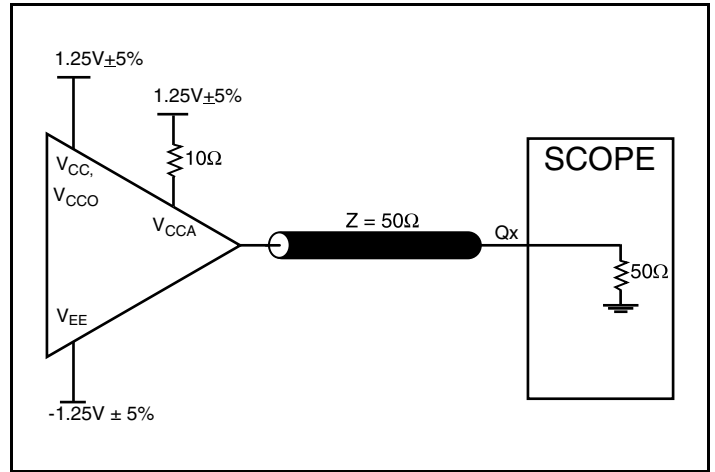

2.5 Core/2.5V LVCMOS Output Load Test Circuit

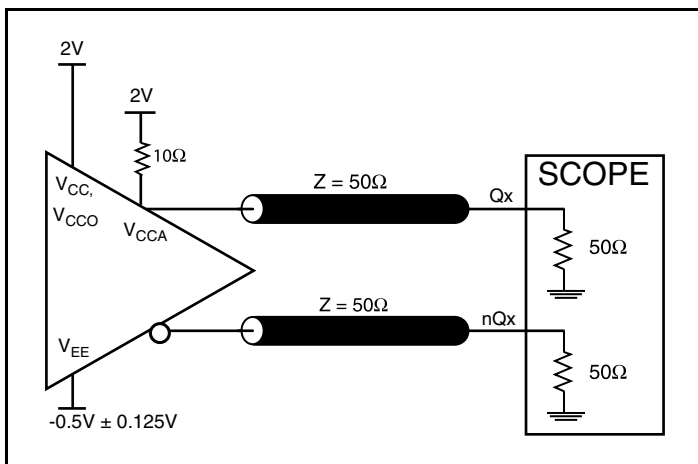

2.5 Core/2.5V LVPECL Output Load Test Circuit

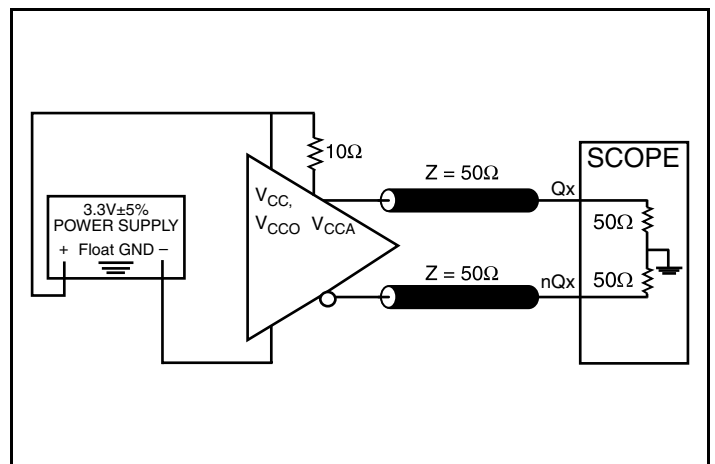

3.3 Core/3.3V LVDS Output Load Test Circuit

Parameter Measurement Information, continued

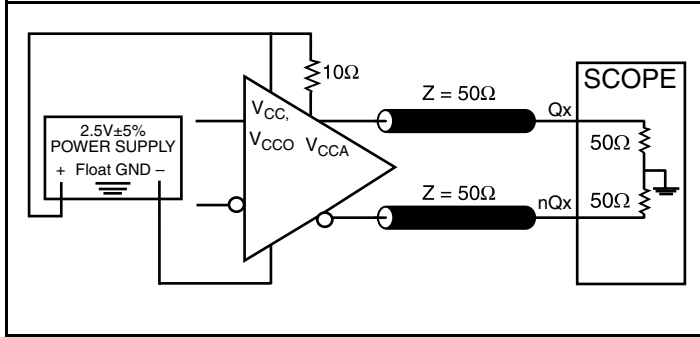

2.5 Core/2.5V LVDS Output Load Test Circuit

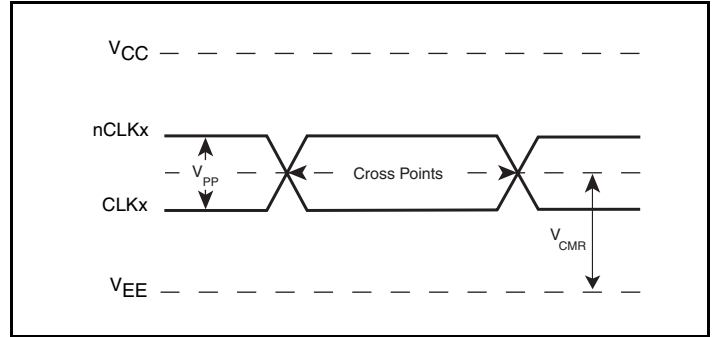

Differential Input Levels

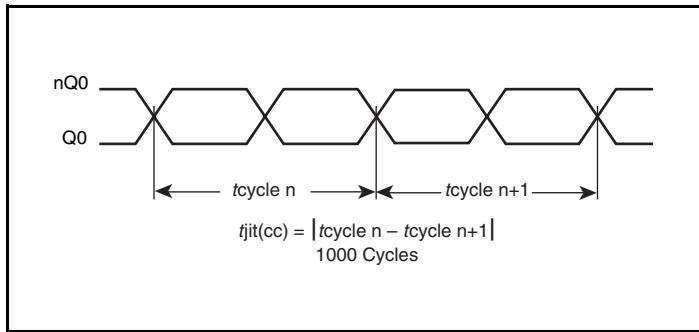

Cycle-to-Cycle Jitter

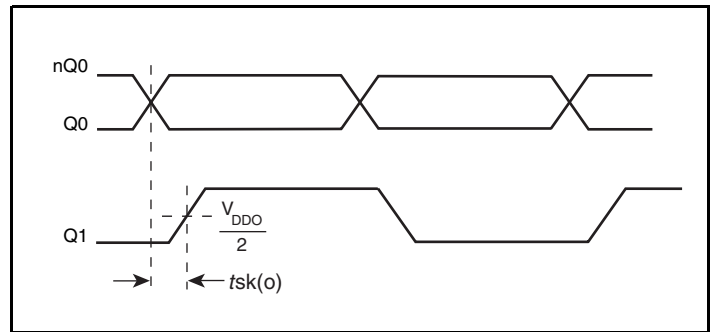

Output Skew

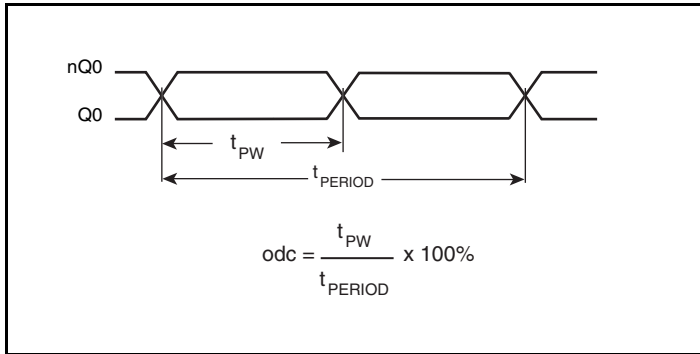

Differential Output Duty Cycle/Output Pulse Width/Period

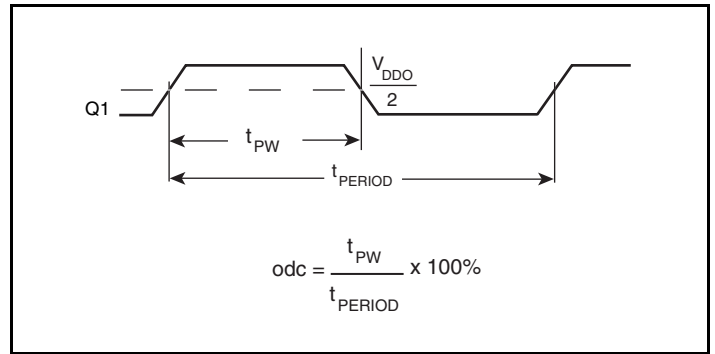

Single-Ended Output Duty Cycle/Output Pulse Width/Period

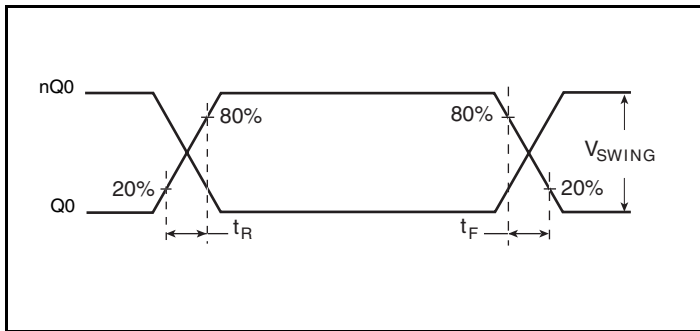

LVPECL Output Rise/Fall Time

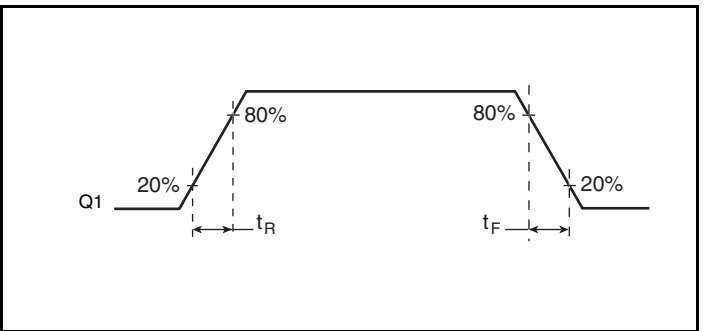

LVCMOS Output Rise/Fall Time



Parameter Measurement Information, continued

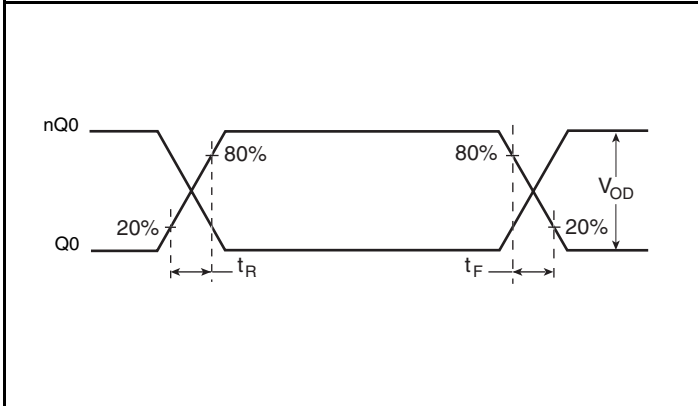

LVDS Output Rise/Fall Time

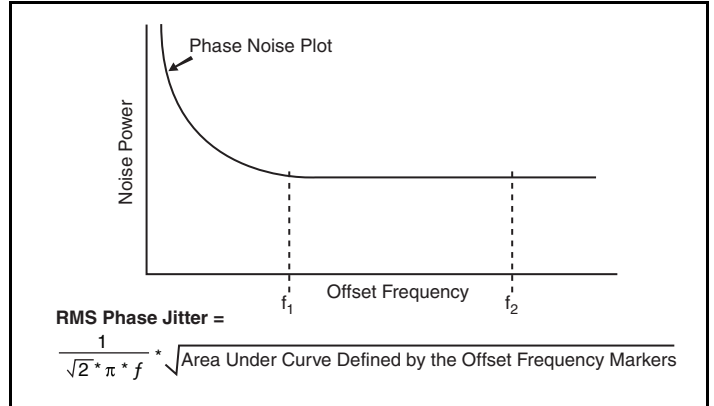

RMS Phase Jitter

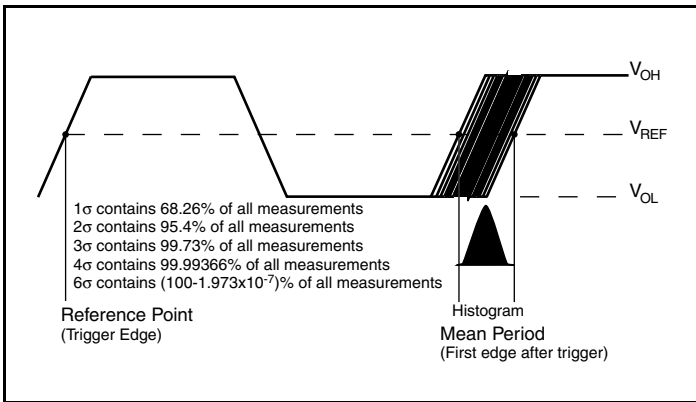

RMS Period Jitter

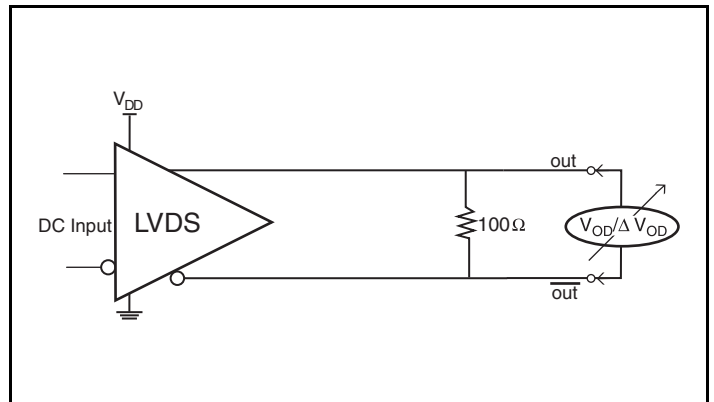

Differential Output Voltage Setup

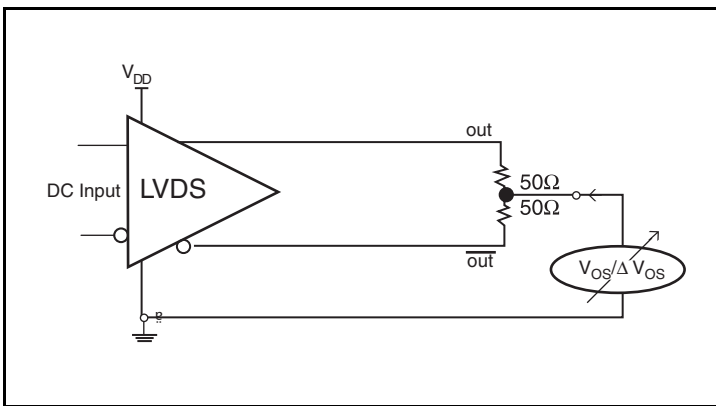

Offset Voltage Setup

## Applications Information

### Recommendations for Unused Input and Output Pins

#### Inputs:

##### Crystal Inputs

For applications not requiring the use of the crystal oscillator input, both XTAL\_IN and XTAL\_OUT can be left floating. Though not required, but for additional protection, a 1k $\Omega$  resistor can be tied from XTAL\_IN to ground.

##### CLKx/nCLKx Inputs

For applications not requiring the use of either differential input, both CLKx and nCLKx can be left floating. Though not required, but for additional protection, a 1k $\Omega$  resistor can be tied from CLKx to ground. It is recommended that CLKx, nCLKx be left unconnected in frequency synthesizer mode.

##### LVC MOS Control Pins

All control pins have internal pullups or putdowns; additional resistance is not required but can be added for additional protection. A 1k $\Omega$  resistor can be used.

#### Outputs:

##### LVPECL Outputs

The unused LVPECL output pair can be left floating. We recommend that there is no trace attached. Both sides of the differential output pair should either be left floating or terminated.

##### LVDS Outputs

The unused LVDS output pair can be either left floating or terminated with 100 $\Omega$  across. If they are left floating there should be no trace attached.

##### LVC MOS Outputs

The unused LVC MOS output can be left floating. There should be no trace attached.

### Recommended Values for Low-Bandwidth Mode Loop Filter

External loop filter components are not needed in Frequency Synthesizer or High-Bandwidth modes. In Low-Bandwidth mode, the loop filter structure and components are recommended, refer to the *Application Schematic*. Please consult IDT if other values are needed.

## Wiring the Differential Input to Accept Single-Ended Levels

Figure 4 shows how a differential input can be wired to accept single ended levels. The reference voltage  $V_{REF} = V_{CC}/2$  is generated by the bias resistors R1 and R2. The bypass capacitor (C1) is used to help filter noise on the DC bias. This bias circuit should be located as close to the input pin as possible. The ratio of R1 and R2 might need to be adjusted to position the  $V_{REF}$  in the center of the input voltage swing. For example, if the input clock swing is 2.5V and  $V_{CC} = 3.3V$ , R1 and R2 value should be adjusted to set  $V_{REF}$  at 1.25V. The values below are for when both the single ended swing and  $V_{CC}$  are at the same voltage. This configuration requires that the sum of the output impedance of the driver ( $R_o$ ) and the series resistance ( $R_s$ ) equals the transmission line impedance. In addition, matched termination at the input will attenuate the signal in half. This can be done in one of two ways. First, R3 and R4 in parallel should equal the transmission

line impedance. For most 50Ω applications, R3 and R4 can be 100Ω. The values of the resistors can be increased to reduce the loading for slower and weaker LVCMOS driver. When using single-ended signaling, the noise rejection benefits of differential signaling are reduced. Even though the differential input can handle full rail LVCMOS signaling, it is recommended that the amplitude be reduced. The datasheet specifies a lower differential amplitude, however this only applies to differential signals. For single-ended applications, the swing can be larger, however  $V_{IL}$  cannot be less than -0.3V and  $V_{IH}$  cannot be more than  $V_{CC} + 0.3V$ . Though some of the recommended components might not be used, the pads should be placed in the layout. They can be utilized for debugging purposes. The datasheet specifications are characterized and guaranteed by using a differential signal.

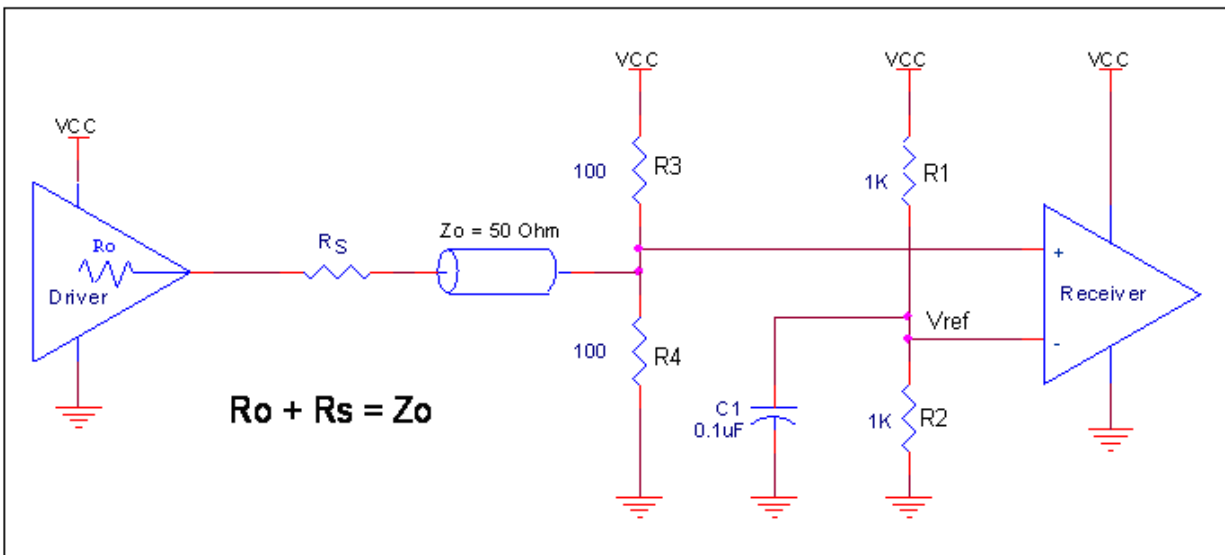

Figure 4. Recommended Schematic for Wiring a Differential Input to Accept Single-ended Levels

## Overdriving the XTAL Interface

The XTAL\_IN input can be overdriven by an LVCMOS driver or by one side of a differential driver through an AC coupling capacitor. The XTAL\_OUT pin can be left floating. The amplitude of the input signal should be between 500mV and 1.8V and the slew rate should not be less than 0.2V/nS. For 3.3V LVCMOS inputs, the amplitude must be reduced from full swing to at least half the swing in order to prevent signal interference with the power rail and to reduce internal noise. *Figure 5A* shows an example of the interface diagram for a high speed 3.3V LVCMOS driver. This configuration requires that the sum of the output impedance of the driver ( $R_o$ ) and the series resistance ( $R_s$ ) equals the transmission line impedance. In addition, matched termination at the crystal input will attenuate the signal in half. This

can be done in one of two ways. First,  $R_1$  and  $R_2$  in parallel should equal the transmission line impedance. For most 50Ω applications,  $R_1$  and  $R_2$  can be 100Ω. This can also be accomplished by removing  $R_1$  and changing  $R_2$  to 50Ω. The values of the resistors can be increased to reduce the loading for a slower and weaker LVCMOS driver. *Figure 5B* shows an example of the interface diagram for an LVPECL driver. This is a standard LVPECL termination with one side of the driver feeding the XTAL\_IN input. It is recommended that all components in the schematics be placed in the layout. Though some components might not be used, they can be utilized for debugging purposes. The datasheet specifications are characterized and guaranteed by using a quartz crystal as the input.

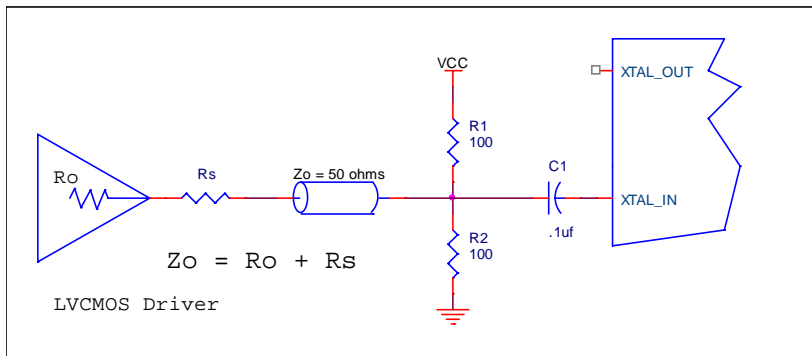

Figure 5A. General Diagram for LVCMOS Driver to XTAL Input Interface

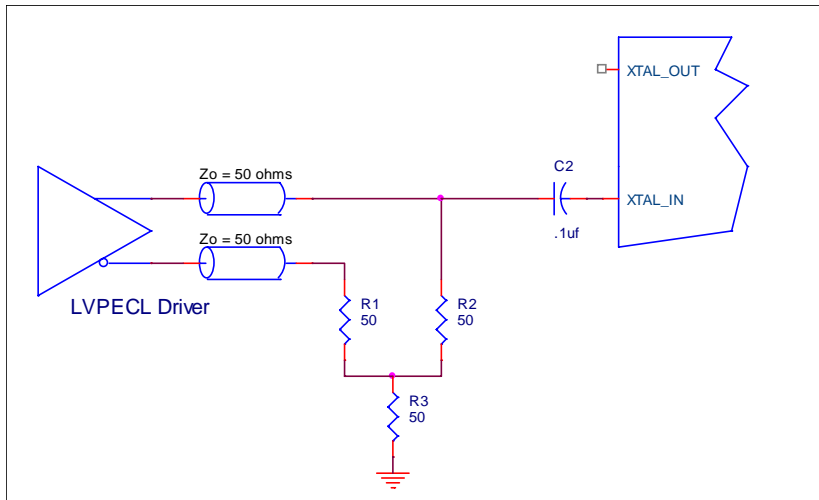

Figure 5B. General Diagram for LVPECL Driver to XTAL Input Interface

## Differential Clock Input Interface

The CLK /nCLK accepts LVDS, LVPECL, LVHSTL, HCSL and other differential signals. Both  $V_{SWING}$  and  $V_{OH}$  must meet the  $V_{PP}$  and  $V_{CMR}$  input requirements. Figures 6A to 6E show interface examples for the CLK/nCLK input driven by the most common driver types. The input interfaces suggested here are examples only. Please consult

with the vendor of the driver component to confirm the driver termination requirements. For example, in Figure 6A, the input termination applies for IDT open emitter LVHSTL drivers. If you are using an LVHSTL driver from another vendor, use their termination recommendation.

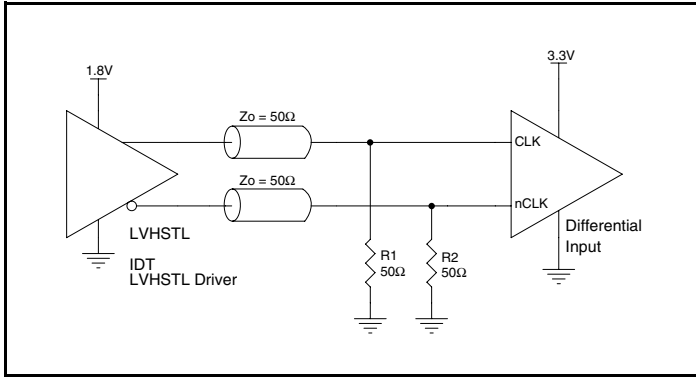

Figure 6A. CLK/nCLK Input Driven by an IDT Open Emitter LVHSTL Driver

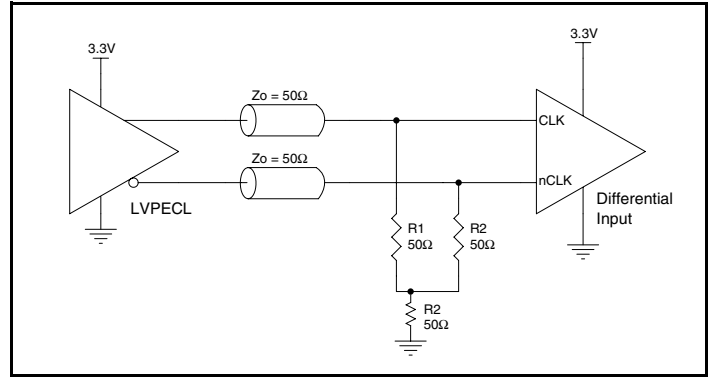

Figure 6B. CLK/nCLK Input Driven by a 3.3V LVPECL Driver

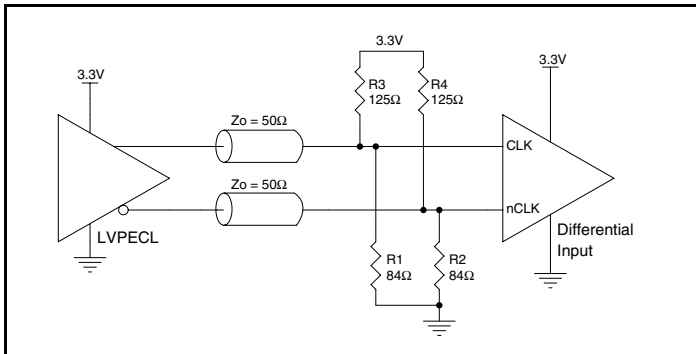

Figure 6C. CLK/nCLK Input Driven by a 3.3V LVPECL Driver

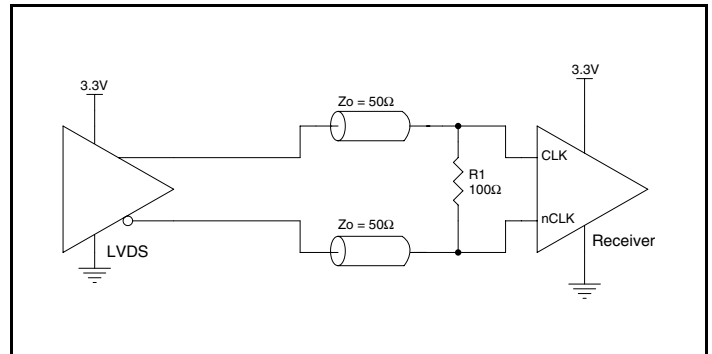

Figure 6D. CLK/nCLK Input Driven by a 3.3V LVDS Driver

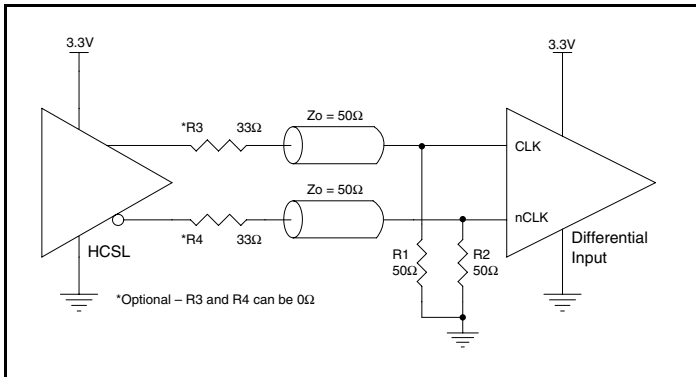

Figure 6E. CLK/nCLK Input Driven by a 3.3V HCSL Driver

## Termination for 3.3V LVPECL Outputs

The clock layout topology shown below is a typical termination for LVPECL outputs. The two different layouts mentioned are recommended only as guidelines.

The differential outputs are low impedance follower outputs that generate ECL/LVPECL compatible outputs. Therefore, terminating resistors (DC current path to ground) or current sources must be used for functionality. These outputs are designed to drive 50Ω

transmission lines. Matched impedance techniques should be used to maximize operating frequency and minimize signal distortion.

Figures 7A and 7B show two different layouts which are recommended only as guidelines. Other suitable clock layouts may exist and it would be recommended that the board designers simulate to guarantee compatibility across all printed circuit and clock component process variations.

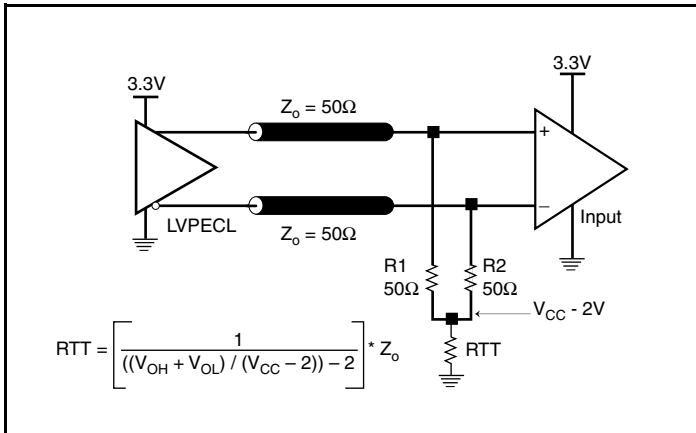

Figure 7A. 3.3V LVPECL Output Termination

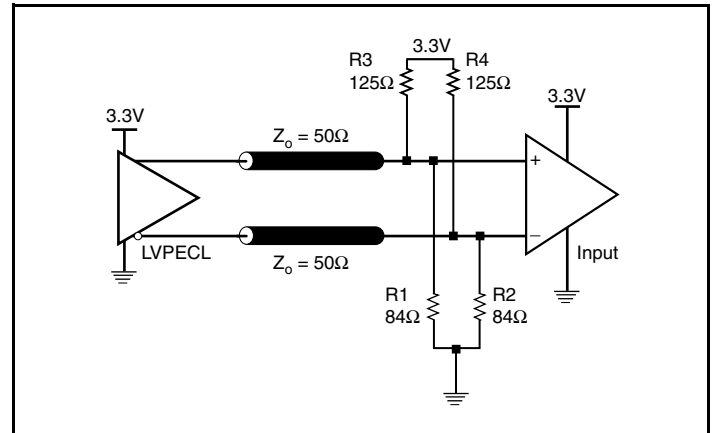

Figure 7B. 3.3V LVPECL Output Termination



## Termination for 2.5V LVPECL Outputs

Figure 8A and Figure 8B show examples of termination for 2.5V LVPECL driver. These terminations are equivalent to terminating  $50\Omega$  to  $V_{CCO} - 2V$ . For  $V_{CCO} = 2.5V$ , the  $V_{CCO} - 2V$  is very close to ground

level. The R3 in Figure 8B can be eliminated and the termination is shown in Figure 8.

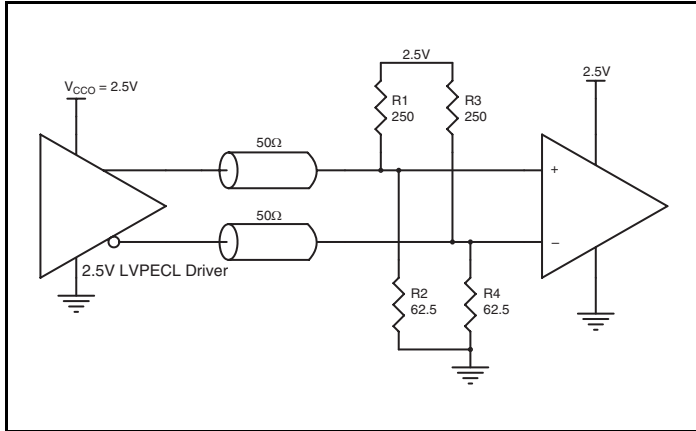

Figure 8A. 2.5V LVPECL Driver Termination Example

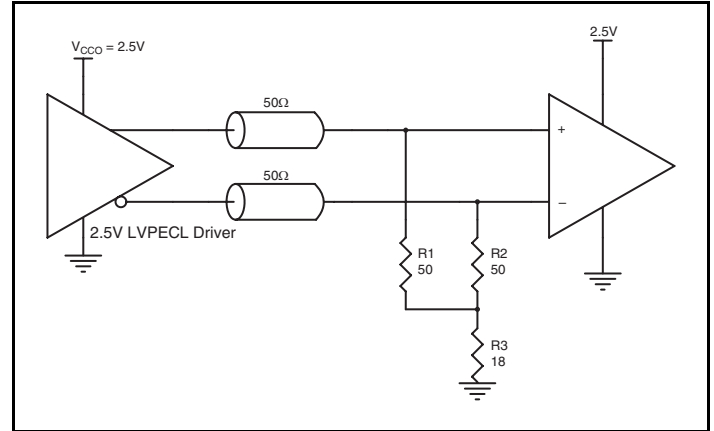

Figure 8B. 2.5V LVPECL Driver Termination Example

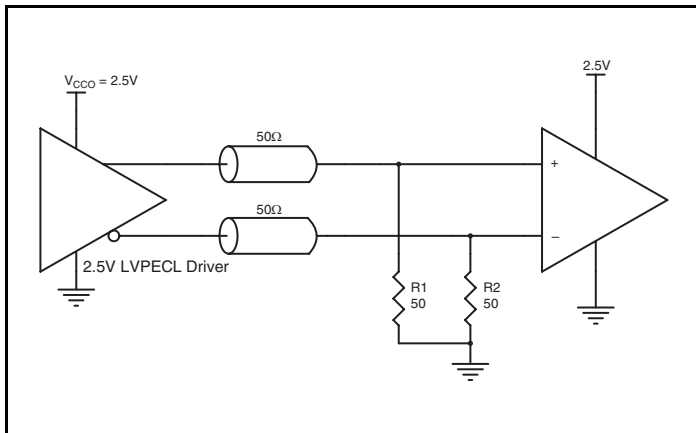

Figure 8C. 2.5V LVPECL Driver Termination Example

## VFQFN EPAD Thermal Release Path

In order to maximize both the removal of heat from the package and the electrical performance, a land pattern must be incorporated on the Printed Circuit Board (PCB) within the footprint of the package corresponding to the exposed metal pad or exposed heat slug on the package, as shown in *Figure 9*. The solderable area on the PCB, as defined by the solder mask, should be at least the same size/shape as the exposed pad/slug area on the package to maximize the thermal/electrical performance. Sufficient clearance should be designed on the PCB between the outer edges of the land pattern and the inner edges of pad pattern for the leads to avoid any shorts.

While the land pattern on the PCB provides a means of heat transfer and electrical grounding from the package to the board through a solder joint, thermal vias are necessary to effectively conduct from the surface of the PCB to the ground plane(s). The land pattern must be connected to ground through these vias. The vias act as “heat pipes”. The number of vias (i.e. “heat pipes”) are application specific

and dependent upon the package power dissipation as well as electrical conductivity requirements. Thus, thermal and electrical analysis and/or testing are recommended to determine the minimum number needed. Maximum thermal and electrical performance is achieved when an array of vias is incorporated in the land pattern. It is recommended to use as many vias connected to ground as possible. It is also recommended that the via diameter should be 12 to 13mils (0.30 to 0.33mm) with 1oz copper via barrel plating. This is desirable to avoid any solder wicking inside the via during the soldering process which may result in voids in solder between the exposed pad/slug and the thermal land. Precautions should be taken to eliminate any solder voids between the exposed heat slug and the land pattern. Note: These recommendations are to be used as a guideline only. For further information, please refer to the Application Note on the Surface Mount Assembly of Amkor’s Thermally/Electrically Enhance Leadframe Base Package, Amkor Technology.

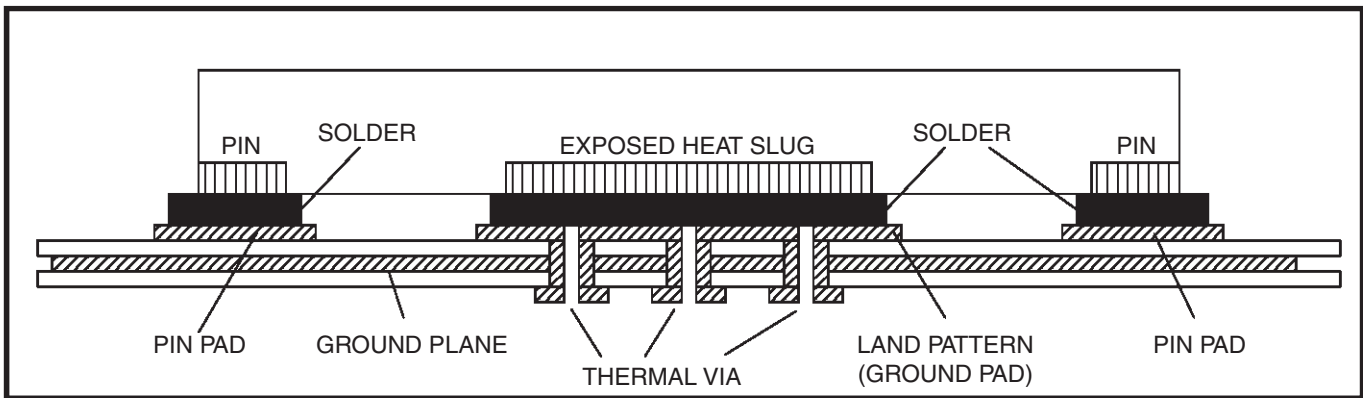

**Figure 9. P.C. Assembly for Exposed Pad Thermal Release Path – Side View (drawing not to scale)**

## Schematic Layout

*Figure 10* (next page shows an example of the ICS849N212I application schematic. Input and output terminations shown are intended as examples only and may not represent the exact user configuration. In this example, the device is operated at  $V_{CC} = 3.3V$ . For 2.5V option, please refer to the “Termination for 2.5V LVPECL Outputs” for output termination recommendation. The decoupling capacitors should be located as close as possible to the power pin. A 12pF parallel resonant 16MHz to 40MHz crystal is used in this example. Different crystal frequencies may be used. The  $C1 = C2 = 5pF$  are recommended for frequency accuracy. If different crystal types are used, please consult IDT for recommendations. For different board layout, the C1 and C2 may be slightly adjusted for optimizing frequency accuracy. It is recommended that the loop filter components be laid out for the 3-pole option. This will also allow either 2-pole or 3-pole filter to be used. The 3-pole filter can be used for additional spur reduction. If a 2-pole filter construction is used, the LF0 and LF1 pins must be tied-together to the filter.

As with any high speed analog circuitry, the power supply pins are vulnerable to random noise. To achieve optimum jitter performance, power supply isolation is required. The ICS849N212I provides separate power supplies to isolate any high switching noise from coupling into the internal PLL.

In order to achieve the best possible filtering, it is recommended that the placement of the filter components be on the device side of the PCB as close to the power pins as possible. If space is limited, the 0.1uf capacitor in each power pin filter should be placed on the device side. The other components can be on the opposite side of the PCB. Power supply filter recommendations are a general guideline to be used for reducing external noise from coupling into the devices. The filter performance is designed for a wide range of noise frequencies. This low-pass filter starts to attenuate noise at approximately 10kHz. If a specific frequency noise component is known, such as switching power supplies frequencies, it is recommended that component values be adjusted and if required, additional filtering be added. Additionally, good general design practices for power plane voltage stability suggests adding bulk capacitance in the local area of all devices.

The schematic example focuses on functional connections and is not configuration specific. Refer to the pin description and functional tables in the datasheet to ensure the logic control inputs are properly set.

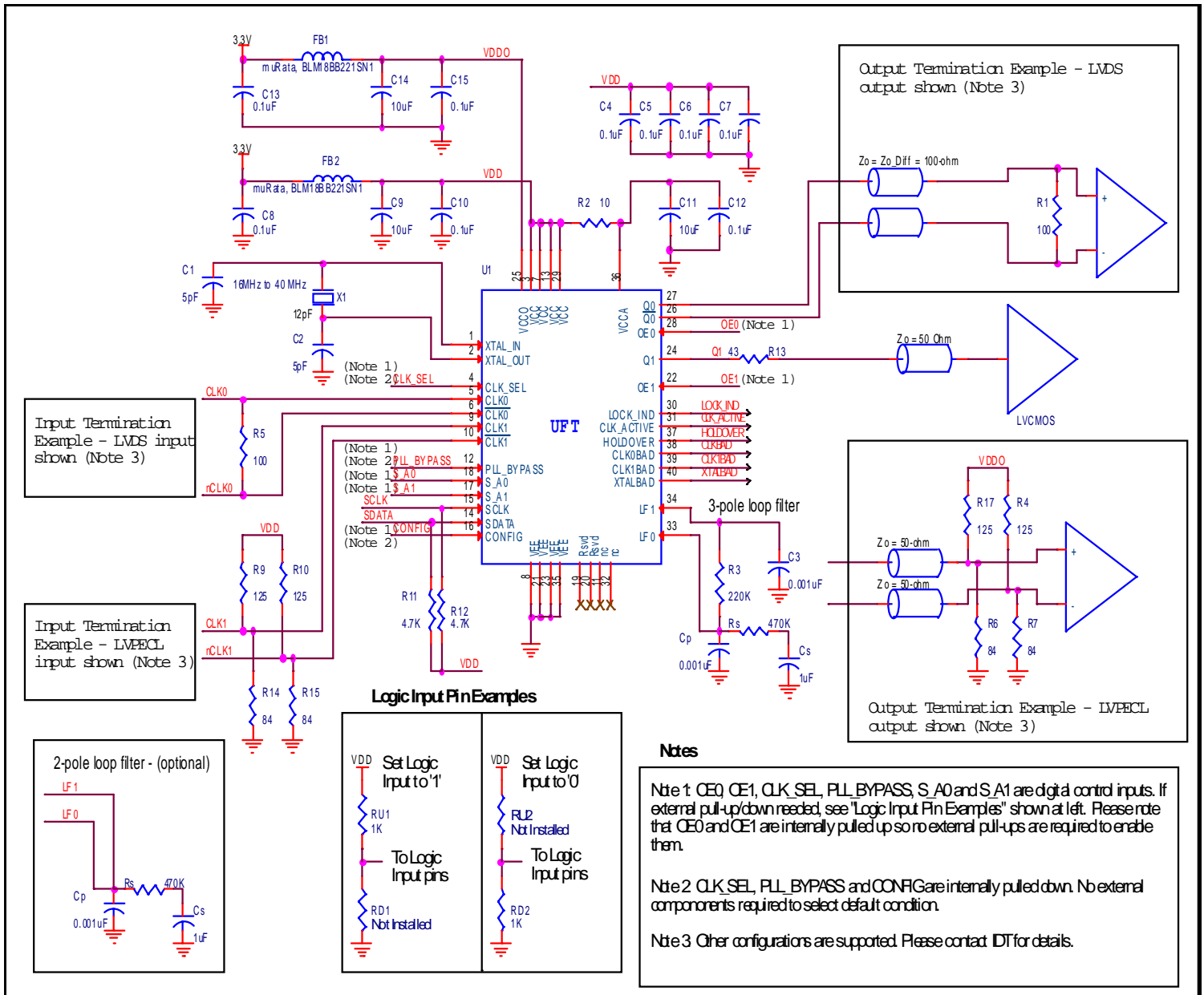

Figure 10. ICS849N212I Schematic Layout

**Notes**

Note 1: CE0, CE1, CLK\_SEL, PLL\_BYPASS, S\_A0 and S\_A1 are digital control inputs. If external pull-up/down needed, see "Logic Input Pin Examples" shown at left. Please note that CE0 and CE1 are internally pulled up so no external pull-ups are required to enable them.

Note 2: CLK\_SEL, PLL\_BYPASS and CONFIG are internally pulled down. No external components required to select default condition.

Note 3: Other configurations are supported. Please contact IDT for details.

### 3.3V LVPECL Power Considerations

This section provides information on power dissipation and junction temperature for the ICS849N212I. Equations and example calculations are also provided.

#### 1. Power Dissipation.

The total power dissipation for the ICS849N212I is the sum of the core power plus the power dissipated in the load(s). The following is the power dissipation for  $V_{CC} = 3.3V + 5\% = 3.465V$ , which gives worst case results.

NOTE: Please refer to Section 3 for details on calculating power dissipated in the load.

- Power (core)<sub>MAX</sub> =  $V_{CC\_MAX} * I_{EE\_MAX} = 3.465V * 320mA = \mathbf{1108.8mW}$
- Power (LVPECL output)<sub>MAX</sub> = 33.2mW/Loaded Output pair

#### LVCMOS Output Power Dissipation

- Output Impedance  $R_{OUT}$  Power Dissipation due to Loading  $50\Omega$  to  $V_{DDO}/2$   
Output Current  $I_{OUT} = V_{DDO\_MAX} / [2 * (50\Omega + R_{OUT})] = 3.465V / [2 * (50\Omega + 15\Omega)] = \mathbf{26.65mA}$
- Power Dissipation on the  $R_{OUT}$  per LVCMOS output  
Power  $(R_{OUT}) = R_{OUT} * (I_{OUT})^2 = 15\Omega * (26.65mA)^2 = \mathbf{10.65mW \text{ per output}}$

#### Total Power Dissipation

- **Total Power**  
= Power (core) + Power (LVPECL output) + Power ( $R_{OUT}$ )  
= 1108.8mW + 33.2mW + 10.65mW = **1153mW**

#### 2. Junction Temperature.

Junction temperature,  $T_j$ , is the temperature at the junction of the bond wire and bond pad directly affects the reliability of the device. The maximum recommended junction temperature is 125°C. Limiting the internal transistor junction temperature,  $T_j$ , to 125°C ensures that the bond wire and bond pad temperature remains below 125°C.

The equation for  $T_j$  is as follows:  $T_j = \theta_{JA} * Pd\_total + T_A$

$T_j$  = Junction Temperature

$\theta_{JA}$  = Junction-to-Ambient Thermal Resistance

$Pd\_total$  = Total Device Power Dissipation (example calculation is in section 1 above)

$T_A$  = Ambient Temperature

In order to calculate junction temperature, the appropriate junction-to-ambient thermal resistance  $\theta_{JA}$  must be used. Assuming no air flow and a multi-layer board, the appropriate value is 32.4°C/W per Table 9 below.

Therefore,  $T_j$  for an ambient temperature of 85°C with all outputs switching is:

$$85^\circ\text{C} + 1.153\text{W} * 32.4^\circ\text{C/W} = 122.4^\circ\text{C}. \text{ This is below the limit of } 125^\circ\text{C}.$$

This calculation is only an example.  $T_j$  will obviously vary depending on the number of loaded outputs, supply voltage, air flow and the type of board (multi-layer).

**Table 9. Thermal Resistance  $\theta_{JA}$  for 40 Lead VFQFN, Forced Convection**

Meters per Second	$\theta_{JA}$ by Velocity		
	0	1	2.5
Multi-Layer PCB, JEDEC Standard Test Boards	32.4°C/W	25.7°C/W	23.4°C/W

### 3. Calculations and Equations.

The purpose of this section is to calculate the power dissipation for the LVPECL output pairs.

LVPECL output driver circuit and termination are shown in *Figure 11*.

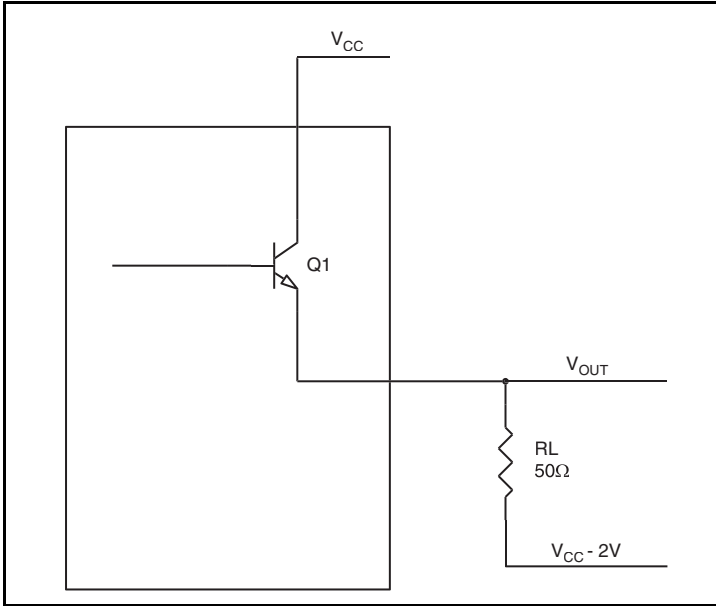

**Figure 11. LVPECL Driver Circuit and Termination**

To calculate power dissipation per output pair due to loading, use the following equations which assume a 50Ω load, and a termination voltage of  $V_{CCO} - 2V$ .

- For logic high,  $V_{OUT} = V_{OH\_MAX} = V_{CCO\_MAX} - 0.7V$   
 $(V_{CCO\_MAX} - V_{OH\_MAX}) = 0.7V$
- For logic low,  $V_{OUT} = V_{OL\_MAX} = V_{CCO\_MAX} - 1.5V$   
 $(V_{CCO\_MAX} - V_{OL\_MAX}) = 1.5V$

$Pd\_H$  is power dissipation when the output drives high.

$Pd\_L$  is the power dissipation when the output drives low.

$$Pd\_H = [(V_{OH\_MAX} - (V_{CCO\_MAX} - 2V))/R_L] * (V_{CCO\_MAX} - V_{OH\_MAX}) = [(2V - (V_{CCO\_MAX} - V_{OH\_MAX}))/R_L] * (V_{CCO\_MAX} - V_{OH\_MAX}) = [(2V - 0.7V)/50\Omega] * 0.7V = \mathbf{18.2mW}$$

$$Pd\_L = [(V_{OL\_MAX} - (V_{CCO\_MAX} - 2V))/R_L] * (V_{CCO\_MAX} - V_{OL\_MAX}) = [(2V - (V_{CCO\_MAX} - V_{OL\_MAX}))/R_L] * (V_{CCO\_MAX} - V_{OL\_MAX}) = [(2V - 1.5V)/50\Omega] * 1.5V = \mathbf{15mW}$$

$$\text{Total Power Dissipation per output pair} = Pd\_H + Pd\_L = \mathbf{33.2mW}$$



### 3.3V LVDS Power Considerations

This section provides information on power dissipation and junction temperature for the ICS849N212I. Equations and example calculations are also provided.

#### 1. Power Dissipation.

The total power dissipation for the ICS849N212I is the sum of the core power plus the power dissipated in the load(s). The following is the power dissipation for  $V_{CC} = 3.3V + 5\% = 3.465V$ , which gives worst case results.

##### Core and LVDS Output Power Dissipation

- Power (core, LVDS)<sub>MAX</sub> =  $V_{CC\_MAX} * (I_{CC\_MAX} + I_{CCA\_MAX}) = 3.465V * (280mA + 30mA) = \mathbf{1074.15mW}$
- Power (output, LVDS)<sub>MAX</sub> =  $V_{CC\_MAX} * I_{CCO} = 3.465V * 40mA = 138.6mW$

##### LVC MOS Output Power Dissipation

- Output Impedance  $R_{OUT}$  Power Dissipation due to Loading  $50\Omega$  to  $V_{DDO}/2$   
Output Current  $I_{OUT} = V_{DDO\_MAX} / [2 * (50\Omega + R_{OUT})] = 3.465V / [2 * (50\Omega + 15\Omega)] = \mathbf{26.65mA}$
- Power Dissipation on the  $R_{OUT}$  per LVC MOS output  
Power  $(R_{OUT}) = R_{OUT} * (I_{OUT})^2 = 15\Omega * (26.65mA)^2 = \mathbf{10.65mW}$  per output

##### Total Power Dissipation

- Total Power**  
= Power (core) + Power (LVDS output) + Power ( $R_{OUT}$ )  
=  $1074.15mW + 138.6mW + 10.65mW = \mathbf{1223.4mW}$

#### 2. Junction Temperature.

Junction temperature,  $T_j$ , is the temperature at the junction of the bond wire and bond pad directly affects the reliability of the device. The maximum recommended junction temperature is  $125^\circ C$ . Limiting the internal transistor junction temperature,  $T_j$ , to  $125^\circ C$  ensures that the bond wire and bond pad temperature remains below  $125^\circ C$ .

The equation for  $T_j$  is as follows:  $T_j = \theta_{JA} * Pd\_total + T_A$

$T_j$  = Junction Temperature

$\theta_{JA}$  = Junction-to-Ambient Thermal Resistance

$Pd\_total$  = Total Device Power Dissipation (example calculation is in section 1 above)

$T_A$  = Ambient Temperature

In order to calculate junction temperature, the appropriate junction-to-ambient thermal resistance  $\theta_{JA}$  must be used. Assuming no air flow and a multi-layer board, the appropriate value is  $32.4^\circ C/W$  per Table 10 below.

Therefore,  $T_j$  for an ambient temperature of  $85^\circ C$  with all outputs switching is:

$$85^\circ C + 1.223W * 32.4^\circ C/W = 124.6^\circ C. \text{ This exceeds the limit of } 125^\circ C.$$

This calculation is only an example.  $T_j$  will obviously vary depending on the number of loaded outputs, supply voltage, air flow and the type of board (multi-layer).

**Table 10. Thermal Resistance  $\theta_{JA}$  for 40 Lead VFQFN, Forced Convection**

$\theta_{JA}$ by Velocity			
Meters per Second	0	1	2.5
Multi-Layer PCB, JEDEC Standard Test Boards	$32.4^\circ C/W$	$25.7^\circ C/W$	$23.4^\circ C/W$

## Reliability Information

**Table 11.  $\theta_{JA}$  vs. Air Flow Table for a 40 Lead VFQFN**

$\theta_{JA}$ vs. Air Flow			
Meters per Second	<b>0</b>	<b>1</b>	<b>2.5</b>
Multi-Layer PCB, JEDEC Standard Test Boards	32.4°C/W	25.7°C/W	23.4°C/W

## Transistor Count

The transistor count for ICS849N212I is: 50,551

## Package Outline and Package Dimensions

### Package Outline - K Suffix for 40 Lead VFQFN

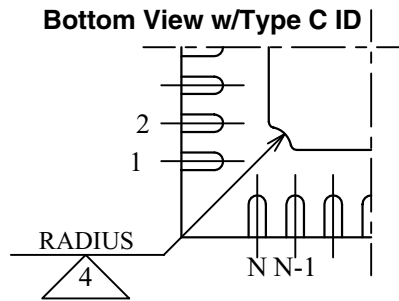
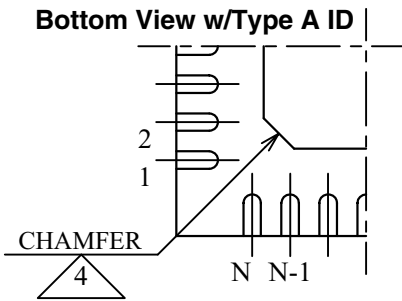
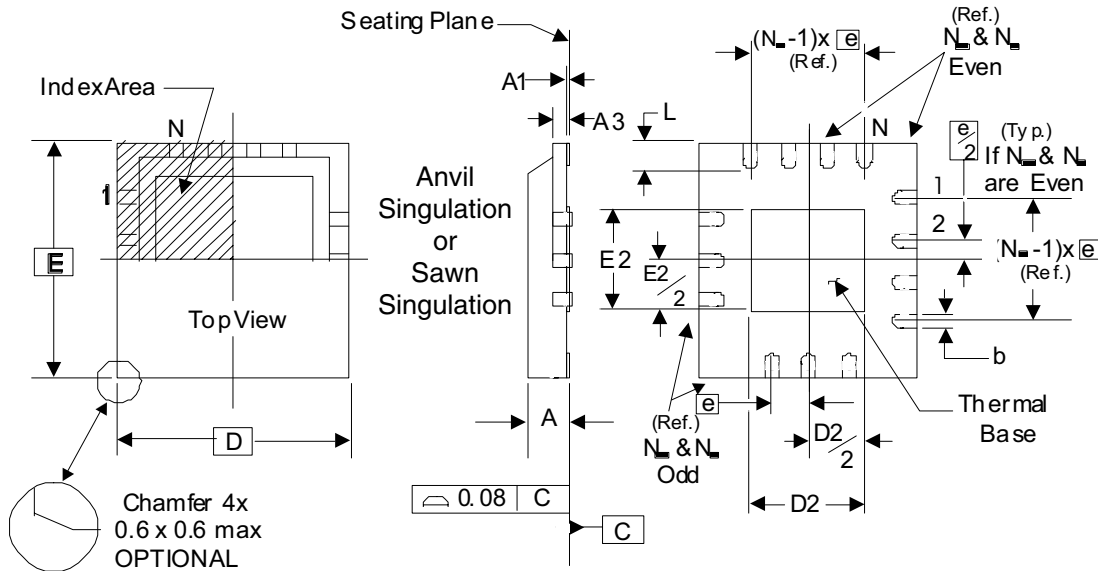

There are 2 methods of indicating pin 1 corner at the back of the VFQFN package are:

1. Type A: Chamfer on the paddle (near pin 1)
2. Type C: Mouse bite on the paddle (near pin 1)

**Table 12. Package Dimensions**

JEDEC Variation: VJJD-2/-5 All Dimensions in Millimeters		
Symbol	Minimum	Maximum
N	40	
A	0.80	1.00
A1	0	0.05
A3	0.25 Ref.	
b	0.18	0.30
$N_D & N_E$	10	
D & E	6.00 Basic	
D2 & E2	4.55	4.75
e	0.50 Basic	
L	0.30	0.50

NOTE: The following package mechanical drawing is a generic drawing that applies to any pin count VFQFN package. This drawing is not intended to convey the actual pin count or pin layout of this device. The pin count and pinout are shown on the front page. The package dimensions are in Table 12.

Reference Document: JEDEC Publication 95, MO-220

## Ordering Information

Table 13. Ordering Information

Part/Order Number	Marking	Package	Shipping Packaging	Temperature
849N212CKI-dddLF	ICS9212CIddd	"Lead-Free" 40 Lead VFQFN	Tray	-40°C to +85°C
849N212CKI-dddLFT	ICS9212CIddd	"Lead-Free" 40 Lead VFQFN	Tape & Reel	-40°C to +85°C

NOTE: For the specific -ddd order codes, refer to *FemtoClock NG Universal Frequency Translator Ordering Product Information* document.

## Revision History Sheet

Rev	Table	Page	Description of Change	Date
B	T5A - TB	13	LVPECL Power Supply DC Characteristic Tables - changed $I_{CCA}$ max. spec from 29mA to 30mA; changed $V_{CCA}$ min spec. from 0.29V to 0.30V.	11/19/2012
	T5C	14	LVPECL Power Supply DC Characteristic Tables - changed $I_{CCA}$ max. spec from 25mA to 26mA; changed $V_{CCA}$ min spec. from 0.25V to 0.26V.	
	T5D	14	LVDS 3.3V Power Supply DC Characteristic Tables - changed $I_{CCA}$ max. spec from 25mA to 30mA; changed $V_{CCA}$ min spec. from 0.25V to 0.30V. Changed $I_{CC}$ from 284mA max. to 280mA max.	
	T5E	14	LVDS 2.5V Power Supply DC Characteristic Tables - changed $I_{CCA}$ max. spec from 26mA to 23mA; changed $V_{CCA}$ min spec. from 0.23V to 0.26V.	
		33	Power Considerations (LVDS Outputs) - corrected equations to coincide with LVDS 3.3V Power Supply Table.	
	T13	36	Ordering Information Table - deleted Tape & Reel count and lead-free note. Errata #NEN-12-07	



## IMPORTANT NOTICE AND DISCLAIMER

RENESAS ELECTRONICS CORPORATION AND ITS SUBSIDIARIES (“RENESAS”) PROVIDES TECHNICAL SPECIFICATIONS AND RELIABILITY DATA (INCLUDING DATASHEETS), DESIGN RESOURCES (INCLUDING REFERENCE DESIGNS), APPLICATION OR OTHER DESIGN ADVICE, WEB TOOLS, SAFETY INFORMATION, AND OTHER RESOURCES “AS IS” AND WITH ALL FAULTS, AND DISCLAIMS ALL WARRANTIES, EXPRESS OR IMPLIED, INCLUDING, WITHOUT LIMITATION, ANY IMPLIED WARRANTIES OF MERCHANTABILITY, FITNESS FOR A PARTICULAR PURPOSE, OR NON-INFRINGEMENT OF THIRD-PARTY INTELLECTUAL PROPERTY RIGHTS.

These resources are intended for developers who are designing with Renesas products. You are solely responsible for (1) selecting the appropriate products for your application, (2) designing, validating, and testing your application, and (3) ensuring your application meets applicable standards, and any other safety, security, or other requirements. These resources are subject to change without notice. Renesas grants you permission to use these resources only to develop an application that uses Renesas products. Other reproduction or use of these resources is strictly prohibited. No license is granted to any other Renesas intellectual property or to any third-party intellectual property. Renesas disclaims responsibility for, and you will fully indemnify Renesas and its representatives against, any claims, damages, costs, losses, or liabilities arising from your use of these resources. Renesas' products are provided only subject to Renesas' Terms and Conditions of Sale or other applicable terms agreed to in writing. No use of any Renesas resources expands or otherwise alters any applicable warranties or warranty disclaimers for these products.

(Disclaimer Rev.1.01 Jan 2024)

### Corporate Headquarters

TOYOSU FORESIA, 3-2-24 Toyosu,  
Koto-ku, Tokyo 135-0061, Japan  
[www.renesas.com](http://www.renesas.com)

### Trademarks

Renesas and the Renesas logo are trademarks of Renesas Electronics Corporation. All trademarks and registered trademarks are the property of their respective owners.

### Contact Information

For further information on a product, technology, the most up-to-date version of a document, or your nearest sales office, please visit [www.renesas.com/contact-us/](http://www.renesas.com/contact-us/).