

ISL32705E

Low-EMI Isolated Full-Duplex RS-485 Transceiver

FN8949
Rev.2.00
Jan 11, 2018

The [ISL32705E](#) is a galvanically isolated, full-duplex differential bus transceiver, designed for bidirectional data transmission meeting the RS-485 and RS-422 standards for balanced communication. All bus terminals are protected against $\pm 7\text{kV}$ ESD strikes without latch-up.

The device uses Giant Magnetoresistance (GMR) as isolation technology. A unique ceramic/polymer composite barrier provides excellent isolation and nearly unlimited barrier life.

The part is available in a 16 Ld wide-body SOIC package providing true 8mm creepage distance.

The ISL32705E delivers a minimum of 1.5V into a 54Ω differential load for excellent data integrity over long cable lengths.

The device is compatible with 3V and 5V input supplies, allowing an interface to standard microcontrollers without additional level shifting.

Current limiting and thermal shutdown features protect against output short-circuits and bus contention that may cause excessive power dissipation. Receiver inputs feature a “fail-safe if open” design, ensuring a logic high R-output if A/B are floating.

Related Literature

- For a full list of related documents, visit our website
- [ISL32705E](#) product page

Features

- 4Mbps data rate
- 2.5kV_{RMS} isolation/600V_{RMS} working voltage
- 3V to 5V power supplies
- Drives up to 44 devices on an isolated bus
- 50kV/μs (typical), 30kV/μs (minimum) common-mode transient immunity
- 44,000 year barrier life
- 7kV ESD protection
- Low EMC footprint
- Thermal shutdown protection
- -40°C to +85°C temperature range
- Meets or exceeds ANSI RS-485
- 0.3” true 8mm 16 Ld SOIC package
- UL 1577 recognized
- VDE V 0884-10 certified

Applications

- Factory automation
- Security networks
- Building environmental control systems
- Industrial/process control networks
- Level translators (for example, RS-232 to RS-485)
- Equipment covered under IEC 61010-1 Edition 3

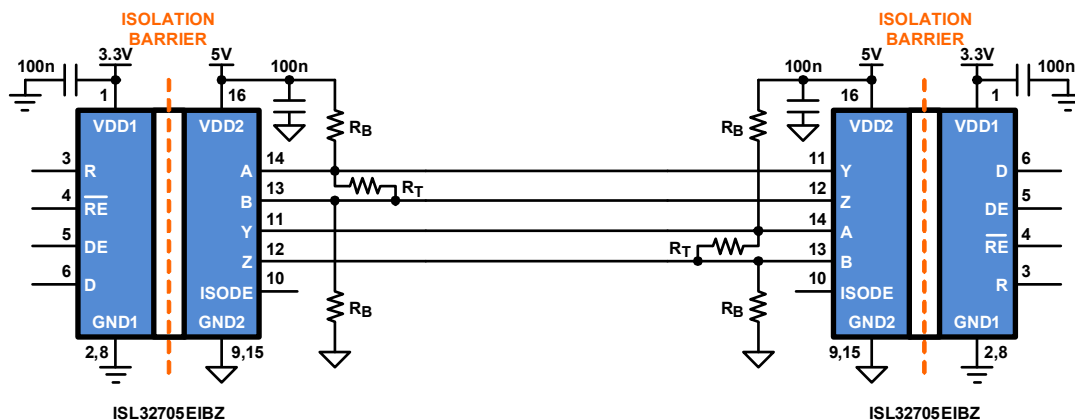

Figure 1. Typical Isolated Full-Duplex RS-485 Application

1. Overview

1.1 Typical Operating Circuit

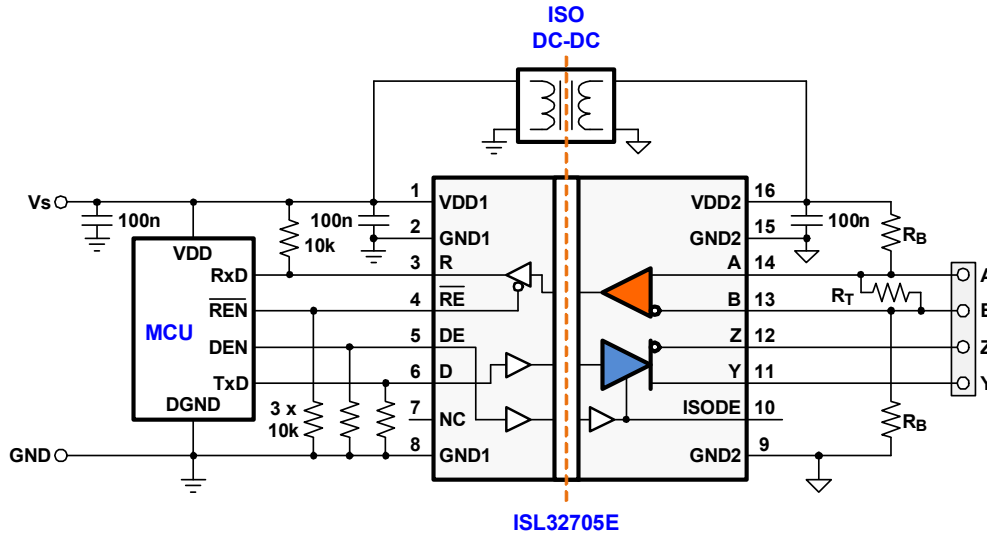

Figure 2. Typical Operating Circuit

1.2 Ordering Information

Part Number (Notes 1, 2, 3)	Part Marking	Temp. Range (°C)	Package (RoHS Compliant)	Pkg. Dwg. #
ISL32705EIBZ	32705EIBZ	-40 to +85	16 Ld SOICW	M16.3A
ISL32705EVAL1Z	Evaluation board for ISL32705EIBZ			

Notes:

1. Add "-T" suffix for 1k unit or "-T7A" suffix for 250 unit tape and reel options. Refer to [TB347](#) for details on reel specifications.
2. Pb-free plus anneal products employ special Pb-free material sets; molding compounds/die attach materials and 100% matte tin plate termination finish, which are RoHS compliant and compatible with both SnPb and Pb-free soldering operations. Pb-free products are MSL classified at Pb-free peak reflow temperatures that meet or exceed the Pb-free requirements of IPC/JEDEC J STD-020.
3. For Moisture Sensitivity Level (MSL), see the product information page for the [ISL32705E](#). For more information on MSL, see [TB363](#).

Table 1. Key Differences Between Family of Parts

Part Number	Full/Half Duplex	V _{DD1} (V)	V _{DD2} (V)	Data Rate (Mbps)	Isolation Voltage (kV _{RMS})
ISL32704E	Half	3.0 – 5.5	4.5 – 5.5	4	2.5
ISL32705E	Full	3.0 – 5.5	4.5 – 5.5	4	2.5
ISL32740E	Half	3.0 – 5.5	4.5 – 5.5	40	2.5
ISL32741E	Half	3.0 – 5.5	4.5 – 5.5	40	6

1.3 Pin Configuration

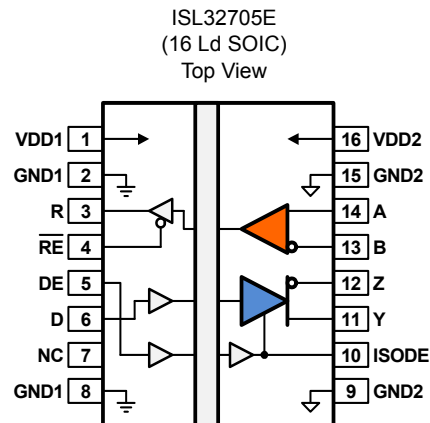

1.4 Truth Tables

Transmitting					
Inputs			Outputs		
\overline{RE}	DE	D	ISODE	Z	Y
X	1	1	1	0	1
X	1	0	1	1	0
0	0	X	0	High-Z	High-Z
1	0	X	0	High-Z	High-Z

Receiving			
Inputs			Output
\overline{RE}	DE	A-B	RO
0	X	$V_{AB} \geq 0.2V$	1
0	X	$0.2V > V_{AB} > -0.2V$	Undetermined
0	X	$V_{AB} \leq -0.2V$	0
0	X	Inputs Open	1
1	X	X	High-Z

1.5 Pin Descriptions

Pin Number	Pin Name	Function
1	VDD1	Input power supply.
2, 8	GND1	Input power supply ground return. Pin 2 is internally connected to Pin 8.
3	R	Receiver output. R is high when $A-B \geq 200\text{mV}$ or A and B are floating. R is low when $A-B \leq -200\text{mV}$.
4	$\overline{\text{RE}}$	Receiver output enable. R is enabled when $\overline{\text{RE}}$ is low; R is high impedance when $\overline{\text{RE}}$ is high.
5	DE	Driver output enable. The driver outputs, Y and Z, are enabled when DE is high. They are high-impedance when DE is low.
6	D	Driver input. A high on D forces output Y high and output Z low. Similarly, a low on D forces output Y low and output Z high.
7	NC	No internal connection.
9, 15	GND2	Output power supply ground return. Pin 9 is internally connected to Pin 15.
10	ISODE	Isolated DE output for use in applications in which the state of the isolated drive enable node needs to be monitored.
11	Y	$\pm 7\text{kV}$ ESD protected noninverting driver output.
12	Z	$\pm 7\text{kV}$ ESD protected inverting driver output.
13	B	$\pm 7\text{kV}$ ESD protected inverting receiver input.
14	A	$\pm 7\text{kV}$ ESD protected noninverting receiver input.
16	VDD2	Output power supply.

2. Specifications

2.1 Absolute Maximum Ratings

Parameter (Note 4)	Minimum	Maximum	Unit
Supply Voltages (Note 7)			
VDD1 to GND1	-0.5	+7	V
VDD2 to GND2		7	V
Input Voltages D, DE, \overline{RE}	-0.5	VDD1 + 0.5	V
Input/Output Voltages			
A, B	-9	+13	V
R	-0.5	VDD1 + 1	V
Short-Circuit Duration A, B	Continuous		V
ESD Rating	See "Electrical Specifications" table on page 6		

Note:

4. Absolute Maximum specifications mean the device will not be damaged if operated under these conditions. It does not guarantee performance.

CAUTION: Do not operate at or near the maximum ratings listed for extended periods of time. Exposure to such conditions may adversely impact product reliability and result in failures not covered by warranty.

2.2 Thermal Information

Thermal Resistance (Typical)	θ_{JA} (°C/W)	θ_{JC} (°C/W)
16 Ld SOICW Package (Notes 5, 6)	60	12

Notes:

5. θ_{JA} is measured in free air with the component soldered to a double-sided board.
 6. For θ_{JC} , the "case temp" location is the center of the package top side.

Parameter	Minimum	Maximum	Unit
Maximum Junction Temperature (Plastic Package)	-55	+150	°C
Maximum Storage Temperature Range	-55	+150	°C
Maximum Power Dissipation		800	mW
Pb-Free Reflow Profile	Refer to TB493		

2.3 Recommended Operation Conditions

Parameter	Minimum	Maximum	Unit
Supply Voltages			
V _{DD1}	3.0	5.5	V
V _{DD2}	4.5	5.5	V
High-Level Digital Input Voltage, V_{IH}			
V _{DD1} = 3.3V	2.4	V _{DD1}	V
V _{DD1} = 5.0V	3.0	V _{DD1}	V
Low-Level Digital Input Voltage, V _{IL}	0	0.8	V
Differential Input Voltage, V _{ID} (Note 8)	-7	12	V

Parameter	Minimum	Maximum	Unit
High-Level Output Current (Driver), I_{OH}		60	mA
High-Level Digital Output Current (Receiver), I_{OH}		8	mA
Low-Level Output Current (Driver), I_{OL}		-60	mA
Low-Level Digital Output Current (Receiver), I_{OL}		-8	mA
Junction Temperature, T_J	-40	+110	°C
Ambient Operating Temperature, T_A	-40	+85	°C
Digital Input Signal Rise and Fall Times, t_{IR} , t_{IF}		DC Stable	

2.4 Electrical Specifications

Test conditions: T_{min} to T_{max} , $V_{DD1} = V_{DD2} = 4.5V$ to $5.5V$; unless otherwise stated. (Note 7)

Parameter	Symbol	Test Conditions	Min	Typ (Note 11)	Max	Unit	
DC Characteristics							
Driver Line Output Voltage (V_A , V_B) (Note 7)	V_O	No load	-	-	V_{DD2}	V	
Driver Differential Output Voltage (Note 8)	V_{OD1}	No load	-	-	V_{DD2}	V	
Driver Differential Output Voltage (Note 8)	V_{OD2}	$R_L = 54\Omega$	1.5	2.3	V_{DD2}	V	
Change in Magnitude of Differential Output Voltage (Note 13)	ΔV_{OD}	$R_L = 54\Omega$ or 100Ω	-	0.01	0.20	V	
Driver Common-Mode Output Voltage	V_{OC}	$R_L = 54\Omega$ or 100Ω	-	-	3	V	
Change in Magnitude of Driver Common-Mode Output Voltage (Note 13)	ΔV_{OC}	$R_L = 54\Omega$ or 100Ω	-	0.01	0.20	V	
Bus Output Current (Y, Z) (Notes 10, 14)	I_{OZD}	$DE = 0V$, $-7V \leq V_O \leq 12V$	-100	-	100	μA	
High-Level Input Current (DI, DE, \overline{RE})	I_{IH}	$V_I = 3.5V$	-	-	10	μA	
Low-Level Input Current (DI, DE, \overline{RE})	I_{IL}	$V_I = 0.4V$	-10	-	-	μA	
Absolute Short-Circuit Output Current	I_{OS}	$DE = V_{DD1}$, $-7V \leq V_A$ or $V_B \leq 12V$	-	-	± 250	mA	
Supply Current	I_{DD1}	$V_{DD1} = 5V$	-	4	6	mA	
		$V_{DD1} = 3.3V$	-	3	4	mA	
Positive-Going Input Threshold Voltage	V_{TH+}	$-7V \leq V_{CM} \leq 12V$	-	-	200	mV	
Negative-Going Input Threshold Voltage	V_{TH-}	$-7V \leq V_{CM} \leq 12V$	-200	-	-	mV	
Receiver Input Hysteresis	V_{HYS}	$V_{CM} = 0V$	-	70	-	mV	
Receiver Output High Voltage	V_{OH}	$I_O = -20\mu A$, $V_{ID} = 200mV$	$V_{DD2} - 0.2$	V_{DD2}	-	V	
Receiver Output Low Voltage	V_{OL}	$I_O = +20\mu A$, $V_{ID} = -200mV$	-	-	0.2	V	
High impedance Output Current	I_{OZR}	$0.4V \leq V_O \leq (V_{DD2} - 0.5)$	-1	-	1	μA	
Bus Input Current (A, B) (Notes 10, 14)	I_{IN}	$DE = 0V$	$V_{IN} = 12V$	-	-	1	mA
			$V_{IN} = -7V$	-0.8	-	-	mA
Receiver Input Resistance	R_{IN}	$-7V \leq V_{CM} \leq 12V$	12	-	-	k Ω	
Supply Current	I_{DD2}	$DE = V_{DD1}$, no load	-	5	16	mA	
ESD Performance							
RS-485 Bus Pins (A, B, Y, Z)		Human Body Model (HBM) discharge to GND2	-	± 7	-	kV	

Test conditions: T_{min} to T_{max} , $V_{DD1} = V_{DD2} = 4.5V$ to $5.5V$; unless otherwise stated. (Note 7) (Continued)

Parameter	Symbol	Test Conditions	Min	Typ (Note 11)	Max	Unit
All Pins (R, RE, D, DE)		Human Body Model (HBM) discharge to GND1	-	±2	-	kV
Switching Characteristics						
$V_{DD1} = 5V, V_{DD2} = 5V$						
Data Rate	DR	$R_L = 54\Omega, C_L = 50pF$	4	-	-	Mbps
Propagation Delay (Notes 8, 15)	t_{PD}	$V_O = -1.5V$ to $1.5V, C_L = 15pF$	-	48	150	ns
Pulse Skew (Notes 8, 16)	$t_{SK}(P)$	$V_O = -1.5V$ to $1.5V, C_L = 15pF$	-	6	15	ns
Output Enable Time to High Level	t_{PZH}	$C_L = 15pF$	-	33	50	ns
Output Enable Time to Low Level	t_{PZL}	$C_L = 15pF$	-	33	50	ns
Output Disable Time from High Level	t_{PHZ}	$C_L = 15pF$	-	33	50	ns
Output Disable Time from Low Level	t_{PLZ}	$C_L = 15pF$	-	33	50	ns
Common-Mode Transient Immunity	CMTI	$V_{CM} = 1500 V_{DC}, t_{TRANSIENT} = 25ns$	30	50	-	kV/ μs
$V_{DD1} = 3.3V, V_{DD2} = 5V$						
Data Rate	DR	$R_L = 54\Omega, C_L = 50pF$	4	-	-	Mbps
Propagation Delay (Notes 8, 15)	t_{PD}	$V_O = -1.5V$ to $1.5V, C_L = 15pF$	-	48	150	ns
Pulse Skew (Notes 8, 16)	$t_{SK}(P)$	$V_O = -1.5V$ to $1.5V, C_L = 15pF$	-	6	20	ns
Output Enable Time to High Level	t_{PZH}	$C_L = 15pF$	-	33	50	ns
Output Enable Time to Low Level	t_{PZL}	$C_L = 15pF$	-	33	50	ns
Output Disable Time from High Level	t_{PHZ}	$C_L = 15pF$	-	33	50	ns
Output Disable Time from Low Level	t_{PLZ}	$C_L = 15pF$	-	33	50	ns
Common-Mode Transient Immunity	CMTI	$V_{CM} = 1500 V_{DC}, t_{TRANSIENT} = 25ns$	30	50	-	kV/ μs

Notes: (apply to both driver and receiver sections)

7. All voltages on the isolator primary side are with respect to GND1, all line voltages and common-mode voltages on the isolator secondary or bus side are with respect to GND2.
8. Differential I/O voltage is measured at the noninverting bus terminal A with respect to the inverting terminal B.
9. Skew limit is the maximum propagation delay difference between any two devices at +25°C.
10. The power-off measurement in ANSI Standard EIA/TIA-422-B applies to disabled outputs only and is not applied to combined inputs and outputs.
11. All typical values are at $V_{DD1}, V_{DD2} = 5V$ or $V_{DD1} = 3.3V$ and $T_A = +25^\circ C$.
12. $-7V < V_{CM} < 12V; 4.5 < V_{DD} < 5.5V$.
13. ΔV_{OD} and ΔV_{OC} are the changes in magnitude of ΔV_{OD} and ΔV_{OC} respectively, that occur when the input is changed from one logic state to the other.
14. This applies for both power-on and power-off; refer to ANSI standard RS-485 for the exact condition. The EIA/TIA-422 -B limit does not apply for a combined driver and receiver terminal.
15. Includes 10ns read enable time. Maximum propagation delay is 25ns after read assertion.
16. Pulse skew is defined as $|t_{PLH} - t_{PHL}|$ of each channel.

2.5 Insulation Specifications

Parameter	Symbol	Test Conditions	Min	Typ	Max	Unit
Creepage Distance (External)		Per IEC 60601	8.03	8.3	-	mm
Total Barrier Thickness (Internal)			13	16	-	μm
Barrier Resistance	R _{IO}	500V	-	>10 ¹⁴	-	Ω
Barrier Capacitance	C _{IO}	f = 1MHz	-	7	-	pF
Leakage Current		240V _{RMS} , 60Hz	-	0.2	-	μA _{RMS}
Comparative Tracking Index	CTI	Per IEC 60112	≥600	-	-	V _{RMS}
High Voltage Endurance (Maximum Barrier Voltage for Indefinite Life)	V _{IO}	At maximum operating temperature	1000	-	-	V _{RMS}
			1500	-	-	V _{DC}
Barrier Life		+100°C, 1000V _{RMS} , 60% C _L activation energy	-	44000	-	Years

2.6 Magnetic Field Immunity

Parameter (Note 17)	Symbol	Test Conditions	Min	Typ	Max	Unit
V_{DD1} = 5V, V_{DD2} = 5V						
Power Frequency Magnetic Immunity	H _{PF}	50Hz/60Hz	2800	3500	-	A/m
Pulse Magnetic Field Immunity	H _{PM}	t _p = 8μs	4000	4500	-	A/m
Damped Oscillatory Magnetic Field	H _{OSC}	0.1Hz to 1MHz	4000	4500	-	A/m
Cross-Axis Immunity Multiplier (Note 18)	K _X		-	2.5	-	
V_{DD1} = 3.3V, V_{DD2} = 5V						
Power Frequency Magnetic Immunity	H _{PF}	50Hz/60Hz	1000	1500	-	A/m
Pulse Magnetic Field Immunity	H _{PM}	t _p = 8μs	1800	2000	-	A/m
Damped Oscillatory Magnetic Field	H _{OSC}	0.1Hz to 1MHz	1800	2000	-	A/m
Cross-Axis Immunity Multiplier (Note 18)	K _X		-	2.5	-	

Notes:

17. The relevant test and measurement methods are given in [“Electromagnetic Compatibility” on page 10](#).

18. External magnetic field immunity is improved by this factor if the field direction is “end-to-end” rather than “pin-to-pin” (See [“Electromagnetic Compatibility” on page 10](#)).

3. Safety and Approvals

3.1 VDE V 0884-10

Basic Isolation; VDE File Number 5016933-4880-0001/229067

- Working voltage (V_{IORM}) $600V_{RMS}$ ($848V_{PK}$); Basic insulation, Pollution degree 2
- Isolation voltage (V_{ISO}) $2500V_{RMS}$
- Transient overvoltage (V_{IOTM}) $4000V_{PK}$
- Each part tested at $1590V_{PK}$ for 1s, 5pC partial discharge limit
- Samples tested at $4000V_{PK}$ for 60s, then $1358V_{PK}$ for 10s with 5pC partial discharge limit

Symbol	Safety-Limiting Values	Value	Unit
T_S	Safety Rating Ambient Temperature	+180	°C
P_S	Safety Rating Power (+180°C)	270	mW
I_S	Supply Current Safety Rating (total of supplies)	54	mA

3.2 UL 1577

Component Recognition Program File Number: E483309

- Each part tested at $3000V_{RMS}$ ($4240V_{PK}$) for 1s
- Each lot samples tested at $2500V_{RMS}$ ($3536V_{PK}$) for 60s

4. Electromagnetic Compatibility

The ISL32705E is fully compliant with generic EMC standards EN50081, EN50082-1, and the umbrella line-voltage standard for Information Technology Equipment (ITE) EN61000. The isolator’s Wheatstone bridge configuration and differential magnetic field signaling ensure excellent EMC performance against all relevant standards. Compliance tests have been conducted in the following categories:

Table 2. Compliance Test Categories

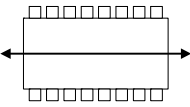
EN50081-1	EN50082-2	EN50204
Residential, Commercial, and Light Industrial: Methods EN55022, EN55014	Industrial Environment EN61000-4-2 (ESD) EN61000-4-3 (Electromagnetic Field Immunity) EN61000-4-4 (EFT) EN61000-4-6 (RFI Immunity) EN61000-4-8 (Power Frequency Magnetic Field immunity) EN61000-4-9 (Pulsed Magnetic Field) EN61000-4-10 (Damped Oscillatory Magnetic Field)	Radiated field from digital telephones
Immunity to external magnetic fields is even higher if the field direction is “end-to-end” rather than “pin-to-pin” as shown on the right.		

5. Application Information

The ISL32705E is an isolated full-duplex RS-485 transceiver designed for high-speed data transmission of up to 4Mbps.

5.1 RS-485 and Isolation

RS-485 is a differential (balanced) data transmission standard for use in long haul networks or noisy environments. It is a true multipoint standard, which allows up to 32 one-unit load devices (any combination of drivers and receivers) on a bus. To allow for multipoint operation, the RS-485 specification requires that drivers must handle bus contention without sustaining any damage.

An important advantage of RS-485 is its wide common-mode range, which specifies that the driver outputs and the receiver inputs withstand signals ranging from +12V to -7V. This common-mode range is the sum of the ground potential difference between driver and receiver, V_{GPD} , the driver output common-mode offset, V_{OC} , and the longitudinally coupled noise along the bus lines, V_n : $V_{CM} = V_{GPD} + V_{OC} + V_n$.

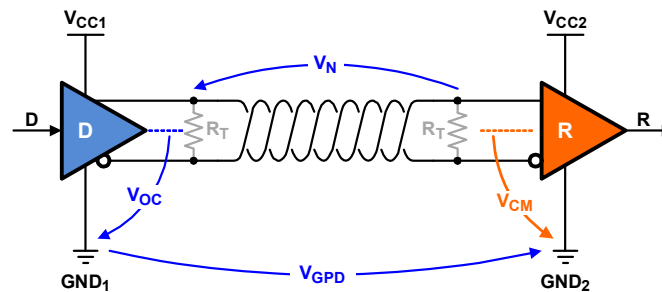

Figure 3. Common-Mode Voltages in a Non-Isolated Data Link

However, in networks using isolated transceivers, such as the ISL32705E, the supply and signal paths of the driver and receiver bus circuits are galvanically isolated from their local mains supplies and signal sources.

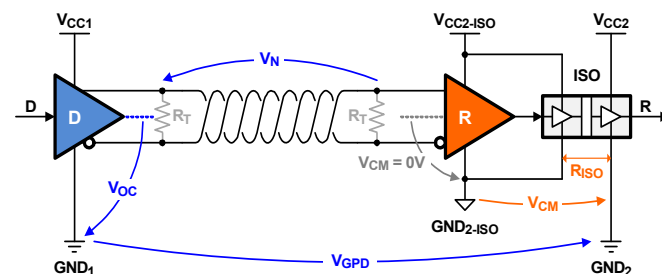

Figure 4. Common-Mode Voltages in an Isolated Data Link

Because the ground potentials of isolated bus nodes are isolated from each other, the common-mode voltage of one node's output has no effect on the bus inputs of another node. This is because the common-mode voltage is dropping across the high-resistance isolation barrier of $10^{14}\Omega$. Thus, galvanic isolation extends the maximum allowable common-mode range of a data link to the maximum working voltage of the isolation barrier, which for the ISL32705E is $600V_{RMS}$.

5.2 Digital Isolator Principle

The ISL32705E uses a Giant Magnetoresistance (GMR) isolation. [Figure 5](#) shows the principle operation of a single channel GMR isolator.

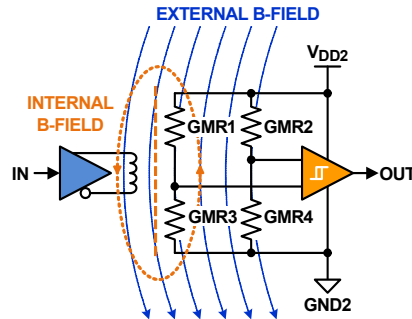

Figure 5. Single Channel GMR Isolator

The input signal is buffered and drives a primary coil, which creates a magnetic field that changes the resistance of the GMR resistors 1 to 4. GMR1 to GMR4 form a Wheatstone bridge to create a bridge output voltage that reacts only to magnetic field changes from the primary coil. Large external magnetic fields however, are treated as common-mode fields, and are therefore suppressed by the bridge configuration. The bridge output is fed into a comparator whose output signal is identical in phase and shape to the input signal.

5.3 GMR Resistor in Detail

[Figure 6](#) shows a GMR resistor consisting of ferromagnetic alloy layers, B1, B2, sandwiched around an ultra thin, nonmagnetic conducting middle layer A, typically copper. The GMR structure is designed so that, in the absence of a magnetic field, the magnetic moments in B1 and B2 face opposite directions, thus causing heavy electron scattering across layer A, which increases its resistance for current C drastically. When a magnetic field D is applied, the magnetic moments in B1 and B2 are aligned and electron scattering is reduced. This lowers the resistance of layer A and increases current C.

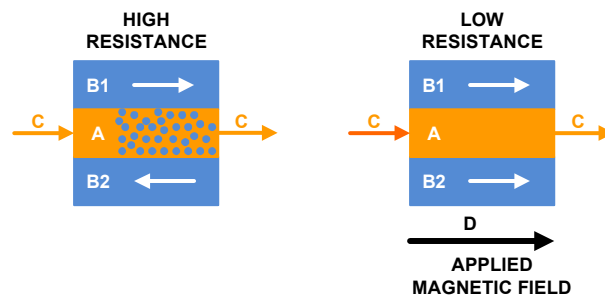

Figure 6. Multilayer GMR Resistor

5.4 Low Emissions

Because GMR isolators do not use complex encoding schemes, such as RF carriers or high-frequency clocks, and do not include power transfer coils or transformers, their radiated emission spectrum is practically undetectable.

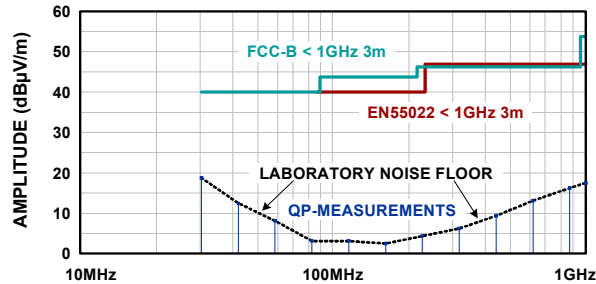

Figure 7. Undetectable Emissions of GMR Isolators

5.5 Low EMI Susceptibility

Because GMR isolators have no pulse trains or carriers to interfere with, they also have very low EMI susceptibility.

For the list of compliance tests conducted on GMR isolators, refer to [“Electromagnetic Compatibility” on page 10](#).

5.6 Receiver (Rx) Features

This transceiver uses a differential input receiver for maximum noise immunity and common-mode rejection. Input sensitivity is $\pm 200\text{mV}$, as required by the RS-485 specification.

The receiver input resistance meets the RS-485 Unit Load (UL) requirement of $12\text{k}\Omega$ minimum. The receiver includes a “fail-safe if open” function that guarantees a high level receiver output if the receiver inputs are unconnected (floating). The receiver output is tri-statable through the active low $\overline{\text{RE}}$ input.

5.7 Driver (Tx) Features

The RS-485 driver is a differential output device that delivers at least 1.5V across a 54Ω purely differential load. The driver features low propagation delay skew to maximize bit width and to minimize EMI.

The driver in the ISL32705E is tri-statable through the active high DE input. The outputs of the ISL32705E driver are not slew rate limited, so faster output transition times allow data rates of at least 4Mbps .

5.8 Built-In Driver Overload Protection

As stated previously, the RS-485 specification requires that drivers survive worst-case bus contentions undamaged. The ISL32705E transmitters meet this requirement through driver output short-circuit current limits and on-chip thermal shutdown circuitry.

The driver output stage incorporates short-circuit current limiting circuitry, which ensures that the output current never exceeds the RS-485 specification. In the event of a major short-circuit condition, the device also includes a thermal shutdown feature that disables the driver whenever the die temperature becomes excessive. This eliminates the power dissipation, allowing the die to cool. The driver automatically re-enables after the die temperature drops about 15°C . If the contention persists, the thermal shutdown/re-enable cycle repeats until the fault is cleared. The receiver stays operational during thermal shutdown.

5.9 Dynamic Power Consumption

The isolator within the ISL32705E achieves its low power consumption from the way it transmits data across the barrier. By detecting the edge transitions of the input logic signal and converting these to narrow current pulses, a magnetic field is created around the GMR Wheatstone bridge. Depending on the direction of the magnetic field, the bridge causes the output comparator to switch following the input signal. Because the current pulses are narrow, about 2.5ns, the power consumption is independent of the mark-to-space ratio and solely depends on frequency.

Table 3. Supply Current Increase with Data Rate

Data Rate (Mbps)	I _{DD1} (mA)	I _{DD2} (mA)
1	0.15	0.15
4	0.6	0.6

5.10 Power Supply Decoupling

Both supplies, V_{DD1} and V_{DD2}, must be bypassed with 100nF ceramic capacitors. These should be placed as close as possible to the supply pins for proper operation.

5.11 DC Correctness

The ISL32705E incorporates a patented refresh circuit to maintain the correct output state with respect to data input. At power-up, the bus outputs follow the [“Truth Tables” on page 3](#). The DE input should be held low during power-up to prevent false drive data pulses on the bus. This can be accomplished by connecting a 10kΩ pull-down resistor between DE and GND1.

5.12 Data Rate, Cables, and Terminations

RS-485 is intended for network lengths up to 4000 feet, but the maximum system data rate decreases as the transmission length increases. Devices operating at 4Mbps are typically limited to lengths less than 100 feet, but are capable of driving up to 350 feet of cable when allowing for some jitter of 5%.

Twisted pair is the cable of choice for RS-485 networks. Twisted pair cables tend to pick up noise and other electromagnetically induced voltages as common-mode signals, which are effectively rejected by the differential receivers in these ICs.

To minimize reflections, proper termination is imperative when using this high data rate transceiver. In point-to-point or point-to-multipoint (single driver on bus) networks, the main cable should be terminated in its characteristic impedance (typically 120Ω for RS-485) at the end farthest from the driver. In multireceiver applications, stubs connecting receivers to the main cable should be kept as short as possible. Multipoint (multidriver) systems require that the main cable be terminated in its characteristic impedance at both ends. Stubs connecting a transceiver to the main cable should be kept as short as possible.

A useful guideline for determining the maximum stub lengths is given with [\(EQ. 1\)](#).

$$(EQ. 1) \quad L_S \leq \frac{t_r}{10} \times v \times c$$

where:

- L_S is the stub length (ft)
- t_r is the driver rise time (s)
- c is the speed of light (9.8 x 10⁸ ft/s)
- v is the signal velocity as a percentage of c

To ensure proper receiver operation during times when the bus is not actively driven, fail-safe biasing networks are used to provide sufficient bus voltage to maintain all receiver outputs logic high.

The point-to-point link in [Figure 8](#) requires only one fail-safe termination at each receiver input. This is due to the unidirectional data traffic.

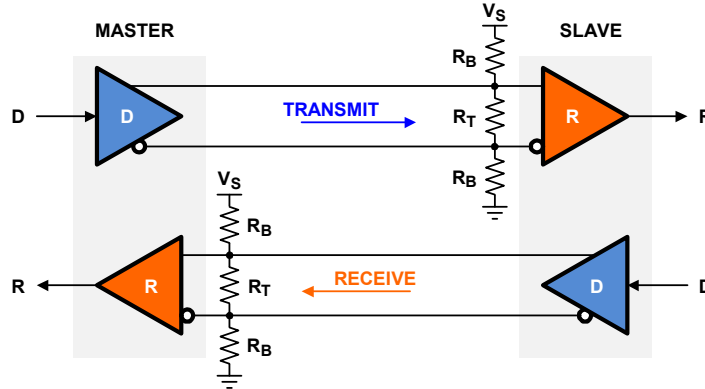

Figure 8. Fail-Safe Biasing Terminations for a Full-Duplex Point-to-Point Data Link

The values for R_B and R_T are calculated using [\(EQ. 2\)](#) and [\(EQ. 3\)](#).

$$(EQ. 2) \quad R_B \geq \frac{Z_0}{2} \times \frac{V_S}{V_{AB}}$$

$$(EQ. 3) \quad R_T = \frac{2R_B \times Z_0}{2R_B - Z_0}$$

where:

- R_B are the fail-safe biasing resistors
- R_T is the termination resistor
- V_S is the minimum transceiver supply
- V_{AB} is the fail-safe bus voltage of the idle bus
- Z_0 is the characteristic cable impedance

The multipoint network in [Figure 9 on page 16](#) requires different termination networks for the transmit and receive path. This is because the transmit path contains only one driver, while the receive path has multiple drivers. The corresponding resistor values are calculated using [\(EQ. 4\)](#) through [\(EQ. 8\)](#).

Transmit Path Termination

$$(EQ. 4) \quad R_B \geq \frac{Z_0}{2} \times \frac{V_S}{V_{AB}}$$

$$(EQ. 5) \quad R_T = \frac{2R_B \times Z_0}{2R_B - Z_0}$$

Receive Path Termination

$$(EQ. 6) \quad R_B \geq \frac{Z_0}{4} \times \frac{V_S}{V_{AB}}$$

$$(EQ. 7) \quad R_{T2} = \frac{2R_B \times Z_0}{2R_B - Z_0}$$

$$(EQ. 8) \quad R_{T1} = Z_0$$

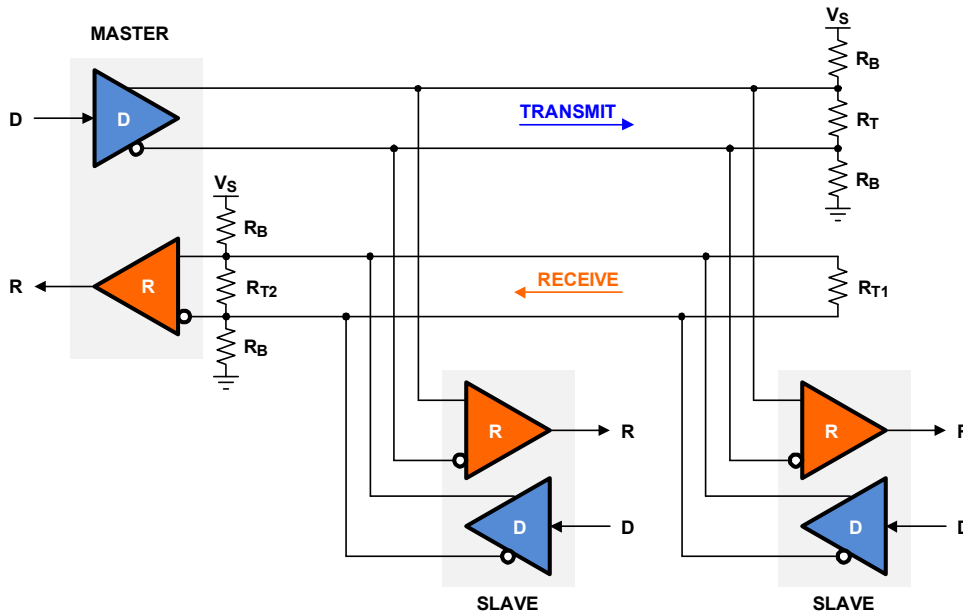

Figure 9. Fail-Safe Biasing Terminations for a Full-Duplex Multipoint Bus

5.13 Transient Protection

Protecting the ISL32705E against transients exceeding the device’s transient immunity requires the addition of external TVS devices. For this purpose, the Semtech RCLAMP0512TQ was chosen due to its high transient protection levels, low junction capacitance, and small form factor.

Table 4. RCLAMP0512 TVS Features

Parameter		Symbol	Value	Unit
ESD (IEC61000-4-2)	Air	V_{ESD}	±30	kV
	Contact	V_{ESD}	±30	kV
EFT (IEC61000-4-4)		V_{EFT}	±4	kV
Surge (IEC61000-4-5)		V_{SURGE}	±1.3	kV
Junction Capacitance		C_J	3	pF
Form Factor		-	1x0.6	mm

The TVS diodes are implemented between the bus lines and isolated ground (GND2).

Because transient voltages on the bus lines are referenced to Earth potential, also known as Protective Earth (PE), a high-voltage capacitor (C_{HV}) is inserted between GND2 and PE, providing a low-impedance path for high-frequency transients.

Note that the connection from the PE point on the isolated side to the PE point on the non-isolated side (Earth) is usually made using the metal chassis of the equipment, or through a short, thick wire of low-inductance.

A high-voltage resistor (R_{HV}) is added in parallel to C_{HV} to prevent the build-up of static charges on floating grounds (GND2) and cable shields. The bill of materials for the circuit in [Figure 10](#) is listed in [Table 5](#).

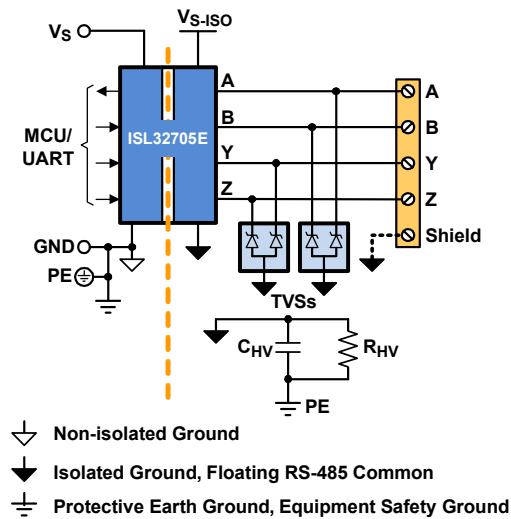

Figure 10. Transient Protection for ISL32705E

Table 5. BOM for Circuit in [Figure 10](#)

Name	Function	Order No.	Vendor
TVS	170W (8, 20 μ s) 2-Line Protector	RCLAMP0512TQ	Semtech
C_{HV}	4.7nF, 2kV, 10% Capacitor	1812B472K202NT	Novacap
R_{HV}	1M Ω , 2kV, 5% Resistor	HVC12061M0JT3	TT-Electronics

6. Revision History

Rev.	Date	Description
2.00	Jan 11, 2018	Changed approvals to UL1577 recognized and VDE V 0884-10 certified on page 1 (2 feature bullets). Removed the units (A/m) in both "Kx" rows on page 8. Removed "Certification Pending" in the VDE header and added the file numbers for VDE and UL. Removed About Intersil section.
1.00	Sep 29, 2017	Updated Table 1 on page 2. Updated receiving truth table on page 3.
0.00	Jul 17, 2017	Initial release

7. Package Outline Drawing

For the most recent package outline drawing, see [M16.3A](#).

M16.3A
 16 LEAD WIDE BODY SMALL OUTLINE PLASTIC PACKAGE (SOICW)
 Rev 1, 6/17

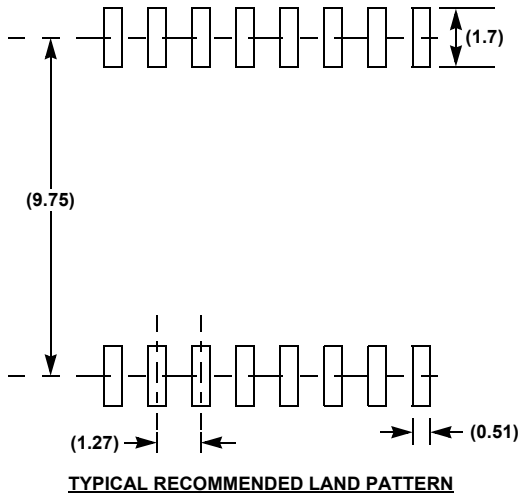
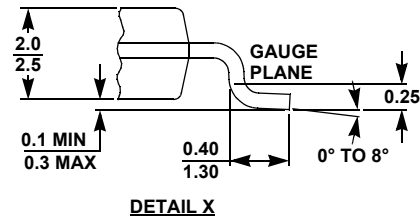
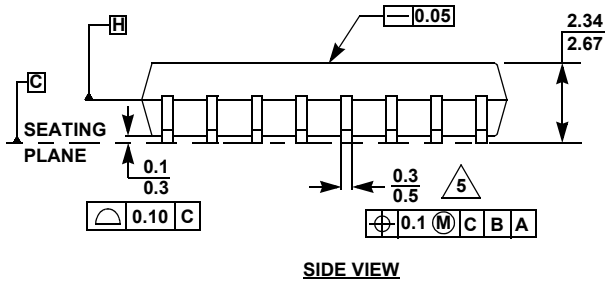
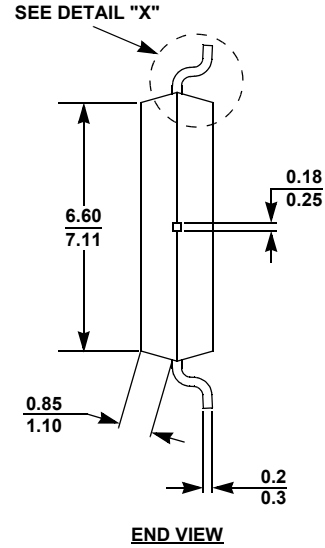
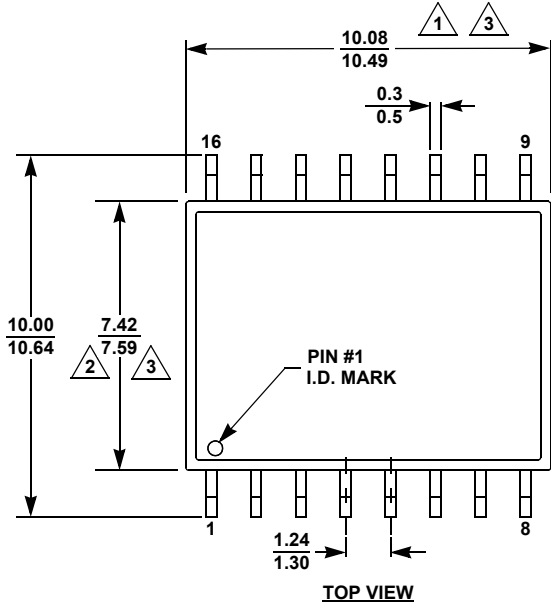

NOTES:

- 1. Dimension does not include mold flash, protrusions, or gate burrs. Mold flash, protrusions, or gate burrs shall not exceed 0.15 per side.
- 2. Dimension does not include interlead flash or protrusion. Interlead flash or protrusion shall not exceed 0.25 per side.
- 3. Dimensions are measured at datum plane H.
- 4. Dimensioning and tolerancing per ASME Y14.5M-1994.
- 5. Dimension does not include dambar protrusion.
- 6. Dimension in () are for reference only.
- 7. Pin spacing is a BASIC dimension; tolerances do not accumulate.
- 8. Dimensions are in mm.

Notice

1. Descriptions of circuits, software and other related information in this document are provided only to illustrate the operation of semiconductor products and application examples. You are fully responsible for the incorporation or any other use of the circuits, software, and information in the design of your product or system. Renesas Electronics disclaims any and all liability for any losses and damages incurred by you or third parties arising from the use of these circuits, software, or information.
2. Renesas Electronics hereby expressly disclaims any warranties against and liability for infringement or any other claims involving patents, copyrights, or other intellectual property rights of third parties, by or arising from the use of Renesas Electronics products or technical information described in this document, including but not limited to, the product data, drawings, charts, programs, algorithms, and application examples.
3. No license, express, implied or otherwise, is granted hereby under any patents, copyrights or other intellectual property rights of Renesas Electronics or others.
4. You shall not alter, modify, copy, or reverse engineer any Renesas Electronics product, whether in whole or in part. Renesas Electronics disclaims any and all liability for any losses or damages incurred by you or third parties arising from such alteration, modification, copying or reverse engineering.
5. Renesas Electronics products are classified according to the following two quality grades: "Standard" and "High Quality". The intended applications for each Renesas Electronics product depends on the product's quality grade, as indicated below.
"Standard": Computers; office equipment; communications equipment; test and measurement equipment; audio and visual equipment; home electronic appliances; machine tools; personal electronic equipment; industrial robots; etc.
"High Quality": Transportation equipment (automobiles, trains, ships, etc.); traffic control (traffic lights); large-scale communication equipment; key financial terminal systems; safety control equipment; etc.
Unless expressly designated as a high reliability product or a product for harsh environments in a Renesas Electronics data sheet or other Renesas Electronics document, Renesas Electronics products are not intended or authorized for use in products or systems that may pose a direct threat to human life or bodily injury (artificial life support devices or systems; surgical implantations; etc.), or may cause serious property damage (space system; undersea repeaters; nuclear power control systems; aircraft control systems; key plant systems; military equipment; etc.). Renesas Electronics disclaims any and all liability for any damages or losses incurred by you or any third parties arising from the use of any Renesas Electronics product that is inconsistent with any Renesas Electronics data sheet, user's manual or other Renesas Electronics document.
6. When using Renesas Electronics products, refer to the latest product information (data sheets, user's manuals, application notes, "General Notes for Handling and Using Semiconductor Devices" in the reliability handbook, etc.), and ensure that usage conditions are within the ranges specified by Renesas Electronics with respect to maximum ratings, operating power supply voltage range, heat dissipation characteristics, installation, etc. Renesas Electronics disclaims any and all liability for any malfunctions, failure or accident arising out of the use of Renesas Electronics products outside of such specified ranges.
7. Although Renesas Electronics endeavors to improve the quality and reliability of Renesas Electronics products, semiconductor products have specific characteristics, such as the occurrence of failure at a certain rate and malfunctions under certain use conditions. Unless designated as a high reliability product or a product for harsh environments in a Renesas Electronics data sheet or other Renesas Electronics document, Renesas Electronics products are not subject to radiation resistance design. You are responsible for implementing safety measures to guard against the possibility of bodily injury, injury or damage caused by fire, and/or danger to the public in the event of a failure or malfunction of Renesas Electronics products, such as safety design for hardware and software, including but not limited to redundancy, fire control and malfunction prevention, appropriate treatment for aging degradation or any other appropriate measures. Because the evaluation of microcomputer software alone is very difficult and impractical, you are responsible for evaluating the safety of the final products or systems manufactured by you.
8. Please contact a Renesas Electronics sales office for details as to environmental matters such as the environmental compatibility of each Renesas Electronics product. You are responsible for carefully and sufficiently investigating applicable laws and regulations that regulate the inclusion or use of controlled substances, including without limitation, the EU RoHS Directive, and using Renesas Electronics products in compliance with all these applicable laws and regulations. Renesas Electronics disclaims any and all liability for damages or losses occurring as a result of your noncompliance with applicable laws and regulations.
9. Renesas Electronics products and technologies shall not be used for or incorporated into any products or systems whose manufacture, use, or sale is prohibited under any applicable domestic or foreign laws or regulations. You shall comply with any applicable export control laws and regulations promulgated and administered by the governments of any countries asserting jurisdiction over the parties or transactions.
10. It is the responsibility of the buyer or distributor of Renesas Electronics products, or any other party who distributes, disposes of, or otherwise sells or transfers the product to a third party, to notify such third party in advance of the contents and conditions set forth in this document.
11. This document shall not be reprinted, reproduced or duplicated in any form, in whole or in part, without prior written consent of Renesas Electronics.
12. Please contact a Renesas Electronics sales office if you have any questions regarding the information contained in this document or Renesas Electronics products.
(Note 1) "Renesas Electronics" as used in this document means Renesas Electronics Corporation and also includes its directly or indirectly controlled subsidiaries.
(Note 2) "Renesas Electronics product(s)" means any product developed or manufactured by or for Renesas Electronics.

(Rev.4.0-1 November 2017)



SALES OFFICES

Renesas Electronics Corporation

<http://www.renesas.com>

Refer to "<http://www.renesas.com/>" for the latest and detailed information.

Renesas Electronics America Inc.
1001 Murphy Ranch Road, Milpitas, CA 95035, U.S.A.
Tel: +1-408-432-8888, Fax: +1-408-434-5351

Renesas Electronics Canada Limited
9251 Yonge Street, Suite 8309 Richmond Hill, Ontario Canada L4C 9T3
Tel: +1-905-237-2004

Renesas Electronics Europe Limited
Dukes Meadow, Millboard Road, Bourne End, Buckinghamshire, SL8 5FH, U.K
Tel: +44-1628-651-700, Fax: +44-1628-651-804

Renesas Electronics Europe GmbH
Arcadiastrasse 10, 40472 Düsseldorf, Germany
Tel: +49-211-6503-0, Fax: +49-211-6503-1327

Renesas Electronics (China) Co., Ltd.
Room 1709 Quantum Plaza, No.27 ZhichunLu, Haidian District, Beijing, 100191 P. R. China
Tel: +86-10-8235-1155, Fax: +86-10-8235-7679

Renesas Electronics (Shanghai) Co., Ltd.
Unit 301, Tower A, Central Towers, 555 Langao Road, Putuo District, Shanghai, 200333 P. R. China
Tel: +86-21-2226-0888, Fax: +86-21-2226-0999

Renesas Electronics Hong Kong Limited
Unit 1601-1611, 16/F., Tower 2, Grand Century Place, 193 Prince Edward Road West, Mongkok, Kowloon, Hong Kong
Tel: +852-2265-6688, Fax: +852-2886-9022

Renesas Electronics Taiwan Co., Ltd.
13F, No. 363, Fu Shing North Road, Taipei 10543, Taiwan
Tel: +886-2-8175-9600, Fax: +886-2-8175-9670

Renesas Electronics Singapore Pte. Ltd.
80 Bendemeer Road, Unit #06-02 Hyflux Innovation Centre, Singapore 339949
Tel: +65-6213-0200, Fax: +65-6213-0300

Renesas Electronics Malaysia Sdn.Bhd.
Unit 1207, Block B, Menara Amcorp, Amcorp Trade Centre, No. 18, Jln Persiaran Barat, 46050 Petaling Jaya, Selangor Darul Ehsan, Malaysia
Tel: +60-3-7955-9390, Fax: +60-3-7955-9510

Renesas Electronics India Pvt. Ltd.
No.777C, 100 Feet Road, HAL 2nd Stage, Indiranagar, Bangalore 560 038, India
Tel: +91-80-67208700, Fax: +91-80-67208777

Renesas Electronics Korea Co., Ltd.
17F, KAMCO Yangjae Tower, 262, Gangnam-daero, Gangnam-gu, Seoul, 06265 Korea
Tel: +82-2-558-3737, Fax: +82-2-558-5338