

Description

The MK2308-2 is a low jitter, low skew, high performance Phase-Lock Loop (PLL) based zero delay buffer for high speed applications. Based on IDT's proprietary low jitter PLL techniques, the device provides eight low skew outputs at speeds up to 133.3 MHz at 3.3 V. The MK2308-2 includes a bank of four outputs running at 1/2X. In the zero delay mode, the rising edge of the input clock is aligned with the rising edges of all eight outputs. Compared to competitive CMOS devices, the MK2308-2 has the lowest jitter.

Features

- Packaged in 16-pin SOIC
- Pb (lead) free package
- Zero input-output delay
- Four 1X outputs plus four 1/2X outputs
- Output to output skew is less than 250 ps
- Output clocks up to 133.3 MHz at 3.3 V
- Ability to generate 2X the input
- Full CMOS outputs with 18 mA output drive capability at TTL levels at 3.3 V
- Spread Smart™ technology works with spread spectrum clock generators
- Advanced, low power, sub micron CMOS process
- Operating voltage of 3.3 V

Block Diagram

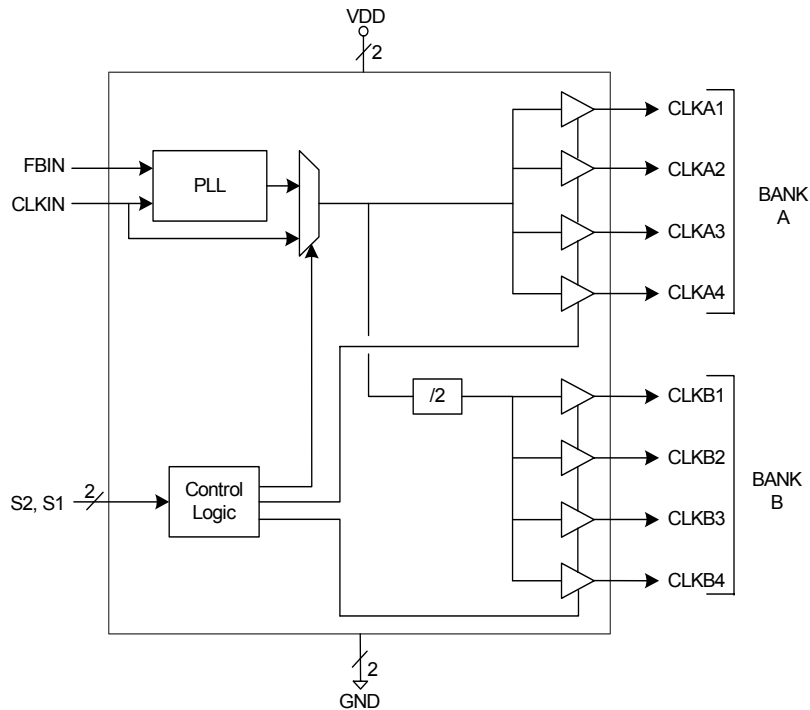

Pin Assignment

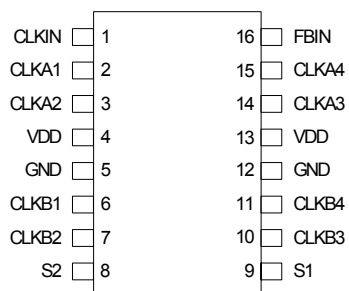

16-pin (150 mil) SOIC

Feedback Configuration Table

Feedback From	CLKA1:A4	CLKB1:B4
Bank A	CLKIN	CLKIN/2
Bank B	2XCLKIN	CLKIN

Output Clock Mode Select Table

S2	S1	Clocks A1:A4	Clocks B1:B4	Internet Generation	PLL Status
0	0	Tri-state (high impedance)	Tri-state (high impedance)	None	On
0	1	Running	Tri-state (high impedance)	PLL	On
1	0	Running	Running	Buffer only (no zero delay)	Off
1	1	Running	Running	PLL	On

Pin Descriptions

Pin Number	Pin Name	Pin Type	Pin Description
1	CLKIN	Input	Clock input. Connect to input clock source.
2 - 3	CLKA1:A4	Output	Clock A bank of four outputs.
4	VDD	Power	Power supply. Connect pin to same voltage as pin 13 (either 3.3 V).
5	GND	Power	Connect to ground.
6 - 7	CLKB1:B4	Output	Clock B bank of four outputs. These are low skew divide by two of bank A.
8	S2	Input	Select input 2. Selects mode for outputs per table above.
9	S1	Input	Select input 1. Selects mode for outputs per table above.
10 - 11	CLKB1:B4	Output	Clock B bank of four outputs. These are low skew divide by two of bank A.
12	GND	Power	Connect to ground.
13	VDD	Power	Power supply. Connect pin to same voltage as pin 4 (either 3.3 V).
14 - 15	CLKA1:A4	Output	Clock A bank of four outputs.
16	FBIN	Input	Feedback input. Determines outputs per table above.

External Components

The MK2308-2 requires a minimum number of external components for proper operation. Decoupling capacitors of 0.1 μ F should be connected between VDD and GND, as close to the part as possible. A 33 Ω series terminating resistor should be used on each clock output to reduce reflections.

Absolute Maximum Ratings

Stresses above the ratings listed below can cause permanent damage to the MK2308-2. These ratings, which are standard values for ICS commercially rated parts, are stress ratings only. Functional operation of the device at these or any other conditions above those indicated in the operational sections of the specifications is not implied. Exposure to absolute maximum rating conditions for extended periods can affect product reliability. Electrical parameters are guaranteed only over the recommended operating temperature range.

Item	Rating
Supply Voltage, VDD	7 V
All Inputs and Outputs	-0.5 V to VDD+0.5 V
Ambient Operating Temperature	0 to +70 °C
Storage Temperature	-65 to +150 °C
Junction Temperature	175 °C
Soldering Temperature	260 °C

Recommended Operation Conditions

Parameter	Min.	Typ.	Max.	Units
Ambient Operating Temperature	0		+70	°C
Power Supply Voltage (measured in respect to GND)	+3.0		+5.5	V

DC Electrical Characteristics

VDD=3.3 V \pm 10%, Temp 0 to +70° / -40 to +85° C

Parameter	Symbol	Conditions	Min.	Typ.	Max.	Units
Operating Voltage	VDD		3.0	3.3	3.6	V
Input High Voltage	V _{IH}	CLKIN pin only	(VDD/2)+1	VDD/2		V
Input Low Voltage	V _{IL}	CLKIN pin only		VDD/2	(VDD/2)-1	V
Input High Voltage	V _{IH}		2			V
Input Low Voltage	V _{IL}				0.8	V
Output High Voltage	V _{OH}	I _{OH} = -18 mA	2.4			V
Output Low Voltage	V _{OL}	I _{OL} = 18 mA			0.4	V
Output High Voltage	V _{OH}	I _{OH} = -5 mA	VDD-0.4			V

Parameter	Symbol	Conditions	Min.	Typ.	Max.	Units
Operating Supply Current 100 MHz, CLKIN	IDD	No Load S1=S2=1		44		mA
Short Circuit Current	I _{OS}	Each output		± 65		mA
Input Capacitance	C _{IN}	S1, S1, FBIN		7		pF

AC Electrical Characteristics

VDD = 3.3V ±10%, Temp 0 to +70°/ -40 to +85° C

Parameter	Symbol	Conditions	Min.	Typ.	Max.	Units
Input Frequency		FBIN to CLKA1 S1=S2=1	20		133. 3	MHz
Output Frequency		FBIN to CLKA1 S1=S2=1	20		133. 3	MHz
Output Rise Time	t _{OR}	0.8 to 2.0 V, C _L =30 pF			1.5	ns
Output Fall Time	t _{OF}	0.8 to 2.0 V, C _L =30 pF			1.5	ns
Output Clock Duty Cycle		at 1.4V	40	50	60	%
Device to Device skew, equally loaded		rising edges at VDD/2			700	ps
Output to Output skew, equally loaded		rising edges at VDD/2			200	ps
Maximum Absolute Jitter				300		ps
Cycle to Cycle Jitter		30 pF loads 66.67 MHz outputs			400	ps
		15 pF loads 66.67 MHz outputs			400	ps
Skew from Output Bank A to Output Bank B		All outputs equally loaded			400	ps
Delay CLKIN Rising Edge to FBIN Rising Edge		measured at VDD/2			±250	ps
PLL Lock Time	t _{LOCK}	Stable power supply, valid clocks on CLKIN, FBIN			1	ms

Thermal Characteristics

Parameter	Symbol	Conditions	Min.	Typ.	Max.	Units
Thermal Resistance Junction to Ambient	θ _{JA}	Still air		120		°C/W
	θ _{JA}	1 m/s air flow		115		°C/W
	θ _{JA}	3 m/s air flow		105		°C/W
Thermal Resistance Junction to Case	θ _{JC}			58		°C/W

Package Outline and Package Dimensions (16-pin SOIC, 150 Mil. Narrow Body)

Package dimensions are kept current with JEDEC Publication No. 95

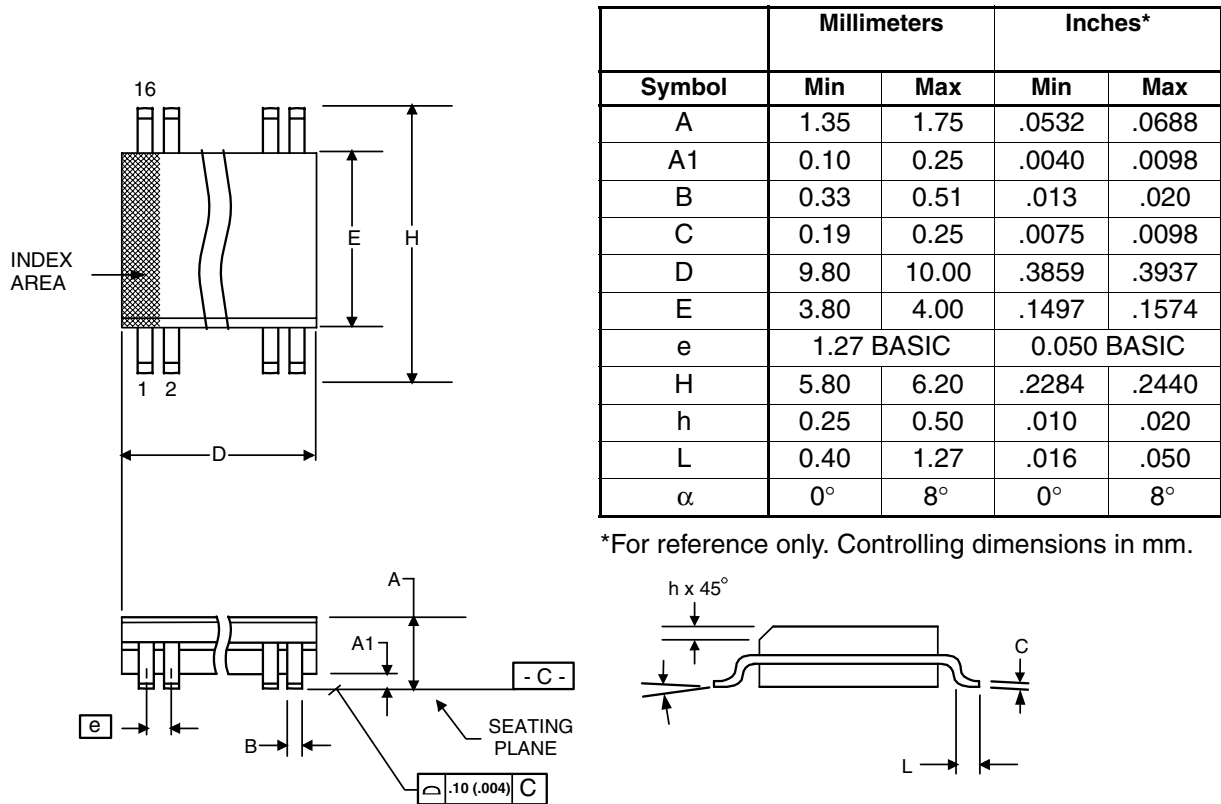

Ordering Information

Part / Order Number	Marking	Shipping Packaging	Package	Temperature
MK2308S-2LF	MK2308S-2LF	Tubes	16-pin SOIC	0 to 70° C
MK2308S-2LFT	MK2308S-2LF	Tape and Reel	16-pin SOIC	0 to 70° C
MK2308S-2ILF	2308S-2ILF	Tubes	16-pin SOIC	-40 to +85° C
MK2308S-2ILFT	2308S-2ILF	Tape and Reel	16-pin SOIC	-40 to +85° C

"LF" suffix to the part number are the Pb-Free configuration and are RoHS compliant.

While the information presented herein has been checked for both accuracy and reliability, Integrated Device Technology (IDT) assumes no responsibility for either its use or for the infringement of any patents or other rights of third parties, which would result from its use. No other circuits, patents, or licenses are implied. This product is intended for use in normal commercial applications. Any other applications such as those requiring extended temperature range, high reliability, or other extraordinary environmental requirements are not recommended without additional processing by IDT. IDT reserves the right to change any circuitry or specifications without notice. IDT does not authorize or warrant any IDT product for use in life support devices or critical medical instruments.

IMPORTANT NOTICE AND DISCLAIMER

RENESAS ELECTRONICS CORPORATION AND ITS SUBSIDIARIES (“RENESAS”) PROVIDES TECHNICAL SPECIFICATIONS AND RELIABILITY DATA (INCLUDING DATASHEETS), DESIGN RESOURCES (INCLUDING REFERENCE DESIGNS), APPLICATION OR OTHER DESIGN ADVICE, WEB TOOLS, SAFETY INFORMATION, AND OTHER RESOURCES “AS IS” AND WITH ALL FAULTS, AND DISCLAIMS ALL WARRANTIES, EXPRESS OR IMPLIED, INCLUDING, WITHOUT LIMITATION, ANY IMPLIED WARRANTIES OF MERCHANTABILITY, FITNESS FOR A PARTICULAR PURPOSE, OR NON-INFRINGEMENT OF THIRD-PARTY INTELLECTUAL PROPERTY RIGHTS.

These resources are intended for developers who are designing with Renesas products. You are solely responsible for (1) selecting the appropriate products for your application, (2) designing, validating, and testing your application, and (3) ensuring your application meets applicable standards, and any other safety, security, or other requirements. These resources are subject to change without notice. Renesas grants you permission to use these resources only to develop an application that uses Renesas products. Other reproduction or use of these resources is strictly prohibited. No license is granted to any other Renesas intellectual property or to any third-party intellectual property. Renesas disclaims responsibility for, and you will fully indemnify Renesas and its representatives against, any claims, damages, costs, losses, or liabilities arising from your use of these resources. Renesas' products are provided only subject to Renesas' Terms and Conditions of Sale or other applicable terms agreed to in writing. No use of any Renesas resources expands or otherwise alters any applicable warranties or warranty disclaimers for these products.

(Disclaimer Rev.1.01)

Corporate Headquarters

TOYOSU FORESIA, 3-2-24 Toyosu,
Koto-ku, Tokyo 135-0061, Japan
www.renesas.com

Trademarks

Renesas and the Renesas logo are trademarks of Renesas Electronics Corporation. All trademarks and registered trademarks are the property of their respective owners.

Contact Information

For further information on a product, technology, the most up-to-date version of a document, or your nearest sales office, please visit www.renesas.com/contact-us/.