

Description

The MK3711D is a drop-in replacement for the original MK3711S device. Compared to these earlier devices, the MK3711D offers a wider operating frequency range and improved power supply noise rejection.

Used in conjunction with an external pullable quartz crystal, this monolithic integrated circuit replaces more costly hybrid (canned) VCXO devices. The MK3711 is designed primarily for data and clock recovery applications within end products such as ADSL modems, set-top box receivers, and telecom systems.

The MK3711D exhibits a moderate VCXO gain of 120ppm/V typical, when used with a high quality external pullable quartz crystal.

The frequency of the on-chip VCXO is adjusted by an external control voltage input into pin VIN. Since VIN is a high impedance input, it can be driven directly from an PWM RC integrator circuit. Frequency output increases with VIN voltage input. The usable range of VIN is 0 to 3V.

Block Diagram

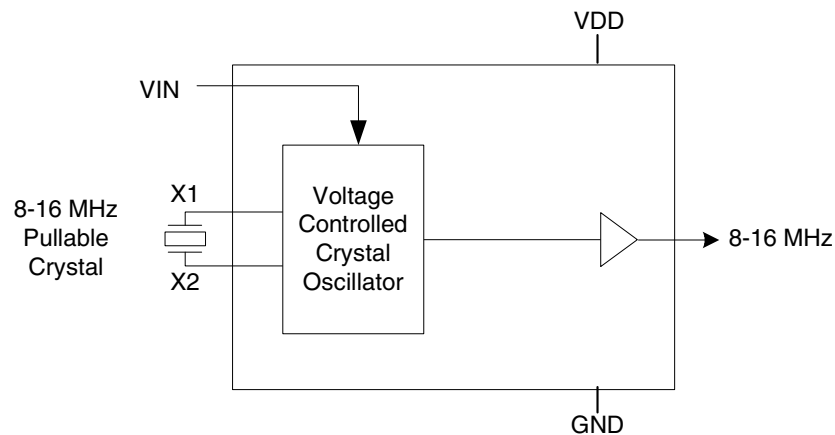

Features

- MK3711D is a drop-in replacement for the earlier MK3711S device
- MK3711D offers an 8-16 MHz output frequency range and improved power supply noise rejection
- Uses an inexpensive 8 to 16 MHz external crystal
- On-chip VCXO with guaranteed pull range of ± 115 ppm minimum
- VCXO tuning voltage 0 to 3.3 V
- Packaged in 8 pin SOIC (150 mil wide)
- Pb (lead) free package
- Industrial temperature range available

MK3711B is Obsolete

Pin Assignment

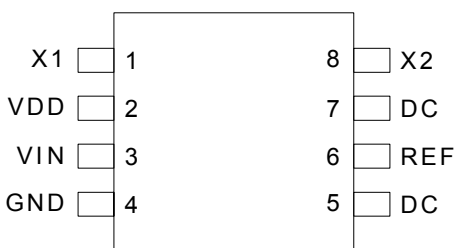

MK3711D

8 Pin (150 mil) SOIC

Pin Descriptions

Pin Number	Pin Name	Pin Type	Pin Description
1	XI	Input	Crystal connection. Connect to the external pullable crystal.
2	VDD	Power	Connect to +3.3 V (0.01uf decoupling capacitor recommended).
3	VIN	Input	Voltage input to VCXO — 0 to 3.3 V analog input which controls the oscillation frequency of the VCXO.
4	GND	Power	Connect to ground.
5	DC	—	Do not connect anything to this pin.
6	REF	Output	VCXO CMOS level clock output matches the nominal frequency of the crystal.
7	DC	—	Do not connect anything to this pin.
8	X2	Input	Crystal connection. Connect to the external pullable crystal.

External Component Selection

The MK3711 requires a minimum number of external components for proper operation.

Decoupling Capacitor

A decoupling capacitor of 0.01 μ F must be connected between VDD (pin 2) and GND (pin 4), as close to these pins as possible. For optimum device performance, the decoupling capacitor should be mounted on the component side of the PCB. Avoid the use of vias in the decoupling circuit.

Series Termination Resistor

When the PCB trace between the clock output (CLK, pin 5) and the load is over 1 inch, series termination should be used. To series terminate a 50 Ω trace (a commonly used trace impedance) place a 33 Ω resistor in series with the clock line, as close to the clock output pin as possible. The nominal impedance of the clock output is 20 Ω .

Quartz Crystal

The MK3711 VCXO function consists of the external crystal and the integrated VCXO oscillator circuit. To assure the best system performance (frequency pull range) and reliability, a crystal device with the recommended parameters (shown below) must be used, and the layout guidelines discussed in the following section shown must be followed.

The frequency of oscillation of a quartz crystal is determined by its "cut" and by the load capacitors connected to it. The MK3711 incorporates on-chip variable load capacitors that "pull" (change) the frequency of the crystal. The crystal specified for use with the MK3711 is designed to have zero frequency error when the total of on-chip + stray capacitance is 14 pF.

Recommended Crystal Parameters:

Initial Accuracy at 25° C	±20 ppm
Temperature Stability	±30 ppm
Aging	±20 ppm
Load Capacitance	14 pf
Shunt Capacitance, C0	7 pF Max
C0/C1 Ratio	250 Max
Equivalent Series Resistance	35 Ω Max

For crystal frequencies between 13.5 MHz and 16 MHz, the nominal crystal load capacitance specification should be 14

pF. Contact IDT applications regarding the use of a crystal below 13.5 MHz.

The external crystal must be connected as close to the chip as possible and should be on the same side of the PCB as the MK3711. There should be no vias between the crystal pins and the X1 and X2 device pins. There should be no signal traces underneath or close to the crystal. See application note MAN05.

Crystal Tuning Load Capacitors

The crystal traces should include pads for small fixed capacitors, one between X1 and ground, and another between X2 and ground. The need for these capacitors is determined at system prototype evaluation, and is influenced by the particular crystal used (manufacture and frequency) and by PCB layout. The typical required capacitor value is 1 to 4 pF.

The procedure for determining the value of these capacitors can be found in application note MAN05.

Absolute Maximum Ratings

Stresses above the ratings listed below can cause permanent damage to the MK3711. These ratings, which are standard values for IDT commercially rated parts, are stress ratings only. Functional operation of the device at these or any other conditions above those indicated in the operational sections of the specifications is not implied. Exposure to absolute maximum rating conditions for extended periods can affect product reliability. Electrical parameters are guaranteed only over the recommended operating temperature range.

Item	Rating
Supply Voltage, VDD	7 V
All Inputs and Outputs	-0.5 V to VDD+0.5 V
Ambient Operating Temperature (commercial)	0 to +70° C
Ambient Operating Temperature (industrial)	-40 to +85° C
Storage Temperature	-65 to +150° C
Soldering Temperature	260° C

Recommended Operating Conditions

Parameter	Min.	Typ.	Max.	Units
Ambient Operating Temperature (commercial)	0		+70	°C
Ambient Operating Temperature (industrial)	-40		+85	°C
Power Supply Voltage (measured in respect to GND)	+3.15		+3.45	V
Reference crystal parameters	Refer to page 3			

DC Electrical Characteristics

VDD=3.3 V ±5% , Ambient temperature -40 to +85° C, unless stated otherwise

Parameter	Symbol	Conditions	Min.	Typ.	Max.	Units
Operating Voltage	VDD		3.15		3.45	V
Output High Voltage	V _{OH}	I _{OH} = -12 mA	2.4			V
Output Low Voltage	V _{OL}	I _{OL} = 12 mA			0.4	V
Output High Voltage (CMOS Level)	V _{OH}	I _{OH} = -4 mA	VDD-0.4			V
Operating Supply Current	IDD	Output = 12 MHz, no load		7		mA
Short Circuit Current	I _{OS}			±50		mA
VIN, VCXO Control Voltage	V _{IA}		0		3.3	V

AC Electrical Characteristics

VDD = 3.3 V ±5%, Ambient Temperature -40 to +85° C, unless stated otherwise

Parameter	Symbol	Conditions	Min.	Typ.	Max.	Units
Output Frequency	F _O		8		16	MHz
Crystal Pullability, Note 2	F _P	0V ≤ VIN ≤ 3.3 V, Note 1	±115			ppm
VCXO Gain						
MK3711D, Note 3		VIN = VDD/2 ± 1 V, Note 1		120		ppm/V
Output Rise Time	t _{OR}	0.8 to 2.0 V, C _L =15 pF			1.5	ns
Output Fall Time	t _{OF}	2.0 to 0.8 V, C _L =15 pF			1.5	ns
Output Clock Duty Cycle	t _D	Measured at 1.4 V, C _L =15 pF	40	50	60	%
Maximum Output Jitter, short term	t _J	C _L =15 pF		100		ps

Note 1: External crystal device must conform with Pullable Crystal Specifications listed on page 3.

Note 2: Original MK3711S and MK3711A provided ±100 ppm crystal pullability.

Note 3: Original MK3711S and MK3711A provided 100 and 170 ppm/V respectively.

Package Outline and Package Dimensions (8-pin SOIC, 150 Mil. Narrow Body)

Package dimensions are kept current with JEDEC Publication No. 95

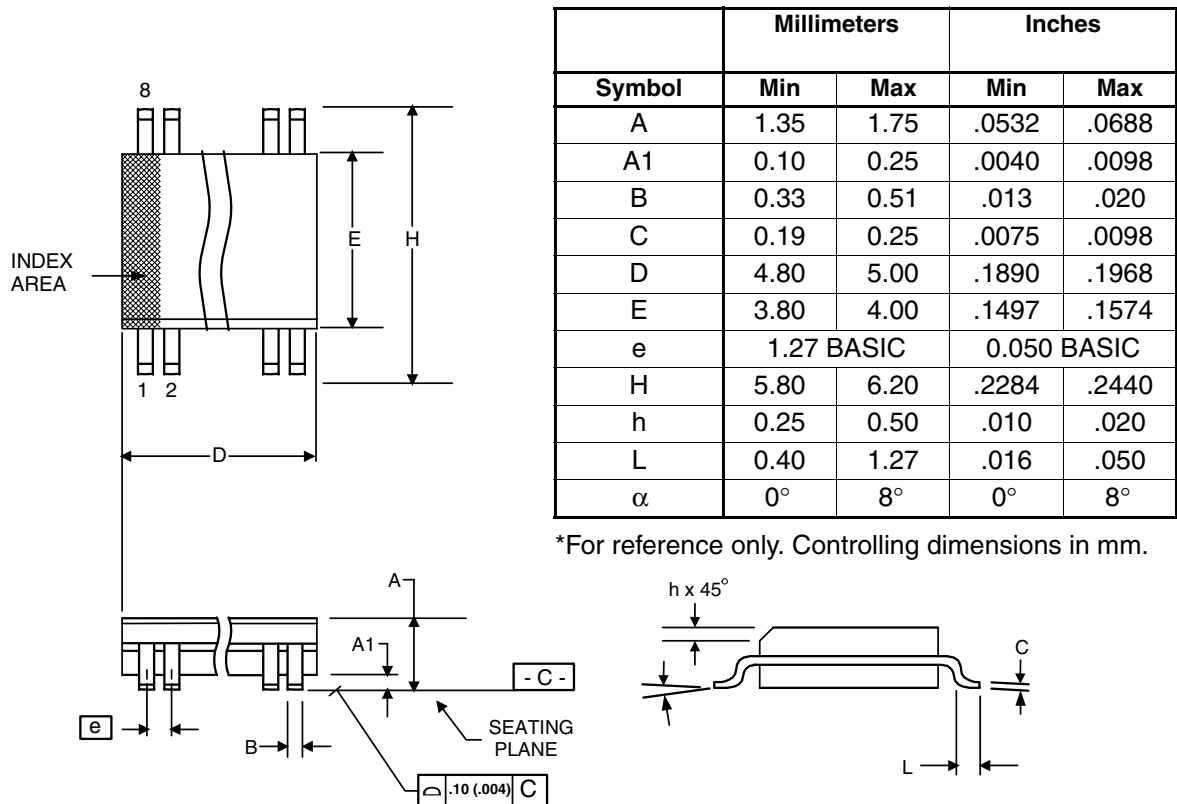

Ordering Information

Part / Order Number	Marking	Shipping Packaging	Package	Temperature
MK3711DMLF	3711DMLF	Tubes	8-pin SOIC	0 to +70° C
MK3711DMLFTR	3711DMLF	Tape and Reel	8-pin SOIC	0 to +70° C
MK3711DMILF	3711DMIL	Tubes	8-pin SOIC	-40 to +85° C
MK3711DMILFTR	3711DMIL	Tape and Reel	8-pin SOIC	-40 to +85° C

"LF" suffix to the part number are the Pb-Free configuration and are RoHS compliant.

While the information presented herein has been checked for both accuracy and reliability, Integrated Device Technology (IDT) assumes no responsibility for either its use or for the infringement of any patents or other rights of third parties, which would result from its use. No other circuits, patents, or licenses are implied. This product is intended for use in normal commercial applications. Any other applications such as those requiring extended temperature range, high reliability, or other extraordinary environmental requirements are not recommended without additional processing by IDT. IDT reserves the right to change any circuitry or specifications without notice. IDT does not authorize or warrant any IDT product for use in life support devices or critical medical instruments.

MK3711

LOW COST 8 TO 16 MHZ 3.3 VOLT VCXO

VCXO AND MULTIPLIER

IMPORTANT NOTICE AND DISCLAIMER

RENESAS ELECTRONICS CORPORATION AND ITS SUBSIDIARIES (“RENESAS”) PROVIDES TECHNICAL SPECIFICATIONS AND RELIABILITY DATA (INCLUDING DATASHEETS), DESIGN RESOURCES (INCLUDING REFERENCE DESIGNS), APPLICATION OR OTHER DESIGN ADVICE, WEB TOOLS, SAFETY INFORMATION, AND OTHER RESOURCES “AS IS” AND WITH ALL FAULTS, AND DISCLAIMS ALL WARRANTIES, EXPRESS OR IMPLIED, INCLUDING, WITHOUT LIMITATION, ANY IMPLIED WARRANTIES OF MERCHANTABILITY, FITNESS FOR A PARTICULAR PURPOSE, OR NON-INFRINGEMENT OF THIRD-PARTY INTELLECTUAL PROPERTY RIGHTS.

These resources are intended for developers who are designing with Renesas products. You are solely responsible for (1) selecting the appropriate products for your application, (2) designing, validating, and testing your application, and (3) ensuring your application meets applicable standards, and any other safety, security, or other requirements. These resources are subject to change without notice. Renesas grants you permission to use these resources only to develop an application that uses Renesas products. Other reproduction or use of these resources is strictly prohibited. No license is granted to any other Renesas intellectual property or to any third-party intellectual property. Renesas disclaims responsibility for, and you will fully indemnify Renesas and its representatives against, any claims, damages, costs, losses, or liabilities arising from your use of these resources. Renesas' products are provided only subject to Renesas' Terms and Conditions of Sale or other applicable terms agreed to in writing. No use of any Renesas resources expands or otherwise alters any applicable warranties or warranty disclaimers for these products.

(Disclaimer Rev.1.01 Jan 2024)

Corporate Headquarters

TOYOSU FORESIA, 3-2-24 Toyosu,
Koto-ku, Tokyo 135-0061, Japan
www.renesas.com

Trademarks

Renesas and the Renesas logo are trademarks of Renesas Electronics Corporation. All trademarks and registered trademarks are the property of their respective owners.

Contact Information

For further information on a product, technology, the most up-to-date version of a document, or your nearest sales office, please visit www.renesas.com/contact-us/.