

Description

The MK3722 is a low cost, low jitter, high performance VCXO and PLL clock synthesizer designed to replace expensive discrete VCXOs and multipliers. The patented on-chip Voltage Controlled Crystal Oscillator accepts a 0 to 3.3 V input voltage to cause the output clocks to vary by ± 115 ppm. Using IDT's analog/digital Phase-Locked Loop (PLL) techniques, the device uses an inexpensive 27 MHz pullable crystal input to produce a reference output and a selectable audio clock.

IDT manufactures the largest variety of VCXO based timing devices for all applications. Consult IDT to eliminate VCXOs, crystals, and oscillators from your board.

The frequency of the on-chip VCXO is adjusted by an external control voltage connected to VIN. Because VIN is a high impedance input, it can be driven directly from an PWM RC integrator circuit.

Features

- Packaged in 16-pin TSSOP
- Pb (lead) free package
- Replaces a VCXO and oscillator
- Operating voltage of 3.3V
- Provides output of 27 MHz plus audio clock
- Uses an inexpensive 27 MHz pullable crystal
- On-chip patented VCXO with pull range of 230 ppm (minimum)
- VCXO tuning voltage of 0 to 3.3 V
- Advanced, low power, sub-micron CMOS process

Block Diagram

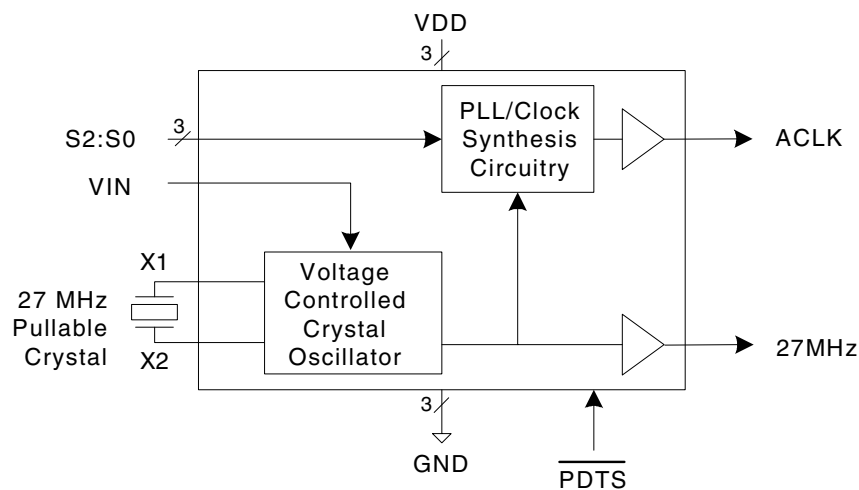

Pin Assignment

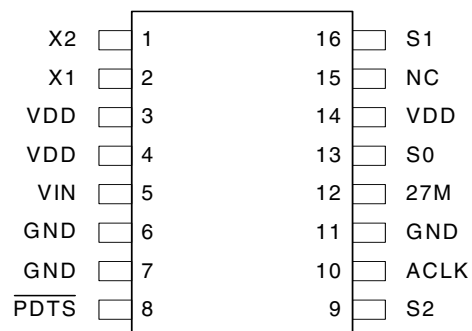

16 Pin 4.40mm body, 0.65mm pitch TSSOP

Audio Clock Select Table

S2	S1	S0	ACLK (MHz)
0	0	0	8.192
0	0	1	11.2896
0	1	0	12.288
0	1	1	16.9344
1	0	0	18.432
1	0	1	16.384
1	1	0	22.5792
1	1	1	24.576

Pin Descriptions

Pin Number	Pin Name	Pin Type	Pin Description
1	X2	Output	Crystal connection. Connect to a 27MHz fundamental mode pullable crystal.
2	X1	Input	Crystal connection. Connect to a 27MHz fundamental mode pullable crystal.
3	VDD	Power	Connect to +3.3 V.
4	VDD	Power	Connect to +3.3 V.
5	VIN	Input	Voltage input to VCXO. Zero to 3.3V signal which controls the VCXO frequency.
6	GND	Power	Connect to ground.
7	GND	Power	Connect to ground.
8	$\overline{\text{PDT S}}$	Power	Power Down Tri-state. This pin powers down entire chip and tri-states the outputs when low. Internal pull-up.
9	S2	Input	Select input S2. Selects ACLK per table above. Internal pull-up.
10	ACLK	Output	Audio clock output per table above.
11	GND	Power	Connect to ground.
12	27M	Output	27MHz reference clock output.
13	S0	Input	Select input S0. Selects ACLK per table above. Internal pull-up.
14	VDD	Power	Connect to +3.3V.
15	NC	--	No connect. Do not connect anything to this pin.
16	S1	Input	Select input S1. Selects ACLK per table above. Internal pull-up.

External Component Selection

The MK3722 requires a minimum number of external components for proper operation.

Decoupling Capacitors

Decoupling capacitors of 0.01 μ F should be connected between VDD and GND on pins 3 and 4, pins 6 and 7, and pins 11 and 14 as close to the MK3722 as possible. For optimum device performance, the decoupling capacitors should be mounted on the component side of the PCB. Avoid the use of vias in the decoupling circuit.

Series Termination Resistor

When the PCB traces between the clock outputs and the loads are over 1 inch, series termination should be used. To series terminate a 50 Ω trace (a commonly used trace impedance) place a 33 Ω resistor in series with the clock line, as close to the clock output pin as possible. The nominal impedance of the clock output is 20 Ω .

Quartz Crystal

The MK3722 VCXO function consists of the external crystal and the integrated VCXO oscillator circuit. To assure the best system performance (frequency pull range) and reliability, a crystal device meeting IDT's recommended parameters must be used, and the layout guidelines discussed in the following section must be followed.

See Application Note MAN05 for a full list of crystal parameters.

The frequency of oscillation of a quartz crystal is determined by its "cut" and by the load capacitors connected to it. The MK3722 incorporates on-chip variable load capacitors that "pull" (change) the frequency of the crystal. The crystal specified for use with the MK3722 is designed to have zero frequency error when the total of on-chip + stray capacitance is 14pF.

The external crystal must be connected as close to the chip as possible and should be on the same side of the PCB as the MK3722. There should be no via's between the crystal pins and the X1 and X2 device pins. There should be no signal traces underneath or close to the crystal.

Crystal Tuning Load Capacitors

The crystal traces should include pads for small fixed

capacitors, one between X1 and ground, and another between X2 and ground. Stuffing of these capacitors on the PCB is optional. The need for these capacitors is determined at system prototype evaluation, and is influenced by the particular crystal used (manufacture and frequency) and by PCB layout. The typical required capacitor value is 1 to 4 pF.

The procedure for determining the value of these capacitors can be found in application note MAN05.

Absolute Maximum Ratings

Stresses above the ratings listed below can cause permanent damage to the MK3722. These ratings, which are standard values for IDT commercially rated parts, are stress ratings only. Functional operation of the device at these or any other conditions above those indicated in the operational sections of the specifications is not implied. Exposure to absolute maximum rating conditions for extended periods can affect product reliability. Electrical parameters are guaranteed only over the recommended operating temperature range.

Item	Rating
Supply Voltage, VDD	7 V
All Inputs and Outputs	-0.5 V to VDD+0.5 V
Ambient Operating Temperature	0 to +70° C
Storage Temperature	-65 to +150° C
Soldering Temperature	260° C

Recommended Operation Conditions

Parameter	Min.	Typ.	Max.	Units
Ambient Operating Temperature	0		+70	°C
Power Supply Voltage (measured in respect to GND)	+3.15		+3.45	V
Reference crystal parameters	Refer to page 3			

DC Electrical Characteristics

VDD=3.3 V ±5% , Ambient temperature 0 to +70° C, unless stated otherwise

Parameter	Symbol	Conditions	Min.	Typ.	Max.	Units
Operating Voltage	VDD		3.15		3.45	V
Output High Voltage	V _{OH}	I _{OH} = -12 mA	2.4			V
Output Low Voltage	V _{OL}	I _{OL} = 12 mA			0.4	V
Output High Voltage (CMOS Level)	V _{OH}	I _{OH} = -4 mA	VDD-0.4			V
Input High Voltage (S1:S0)	V _{IH}		2.0			V
Input High Voltage (S2)	V _{IH}		2.5			V
Input Low Voltage (S1:S0)	V _{IL}				0.8	V
Input Low Voltage (S2)	V _{IL}				0.5	V
Operating Supply Current	I _{DD}	No load, 2 outputs		11		mA
Short Circuit Current	I _{OS}			±50		mA
VIN, VCXO Control Voltage	V _{IA}		0		3.3	V
On Chip Pull-up Resistor, inputs	R _{PU}	S0, S1, S2		150		kΩ
Input Capacitance	C _{IN}	S0, S1, S2		5		pF
Nominal Output Impedance	Z _{OUT}			20		Ω

AC Electrical Characteristics

VDD = 3.3 V ±5%, Ambient Temperature 0 to +70° C, unless stated otherwise

Parameter	Symbol	Conditions	Min.	Typ.	Max.	Units
Crystal Pullability	f_P	$0V \leq V_{IN} \leq 3.3V$, Note 1	± 100			ppm
VCXO Gain		$V_{IN} = V_{DD}/2 \pm 1V$, Note 1		80		ppm/V
Output Rise Time	t_{OR}	0.8 to 2.0 V, $C_L=15$ pF		0.75	1.5	ns
Output Fall Time	t_{OF}	2.0 to 0.8 V, $C_L=15$ pF		0.75	1.5	ns
Output Clock Duty Cycle	t_D	Measured at 1.65 V, $C_L=15$ pF	40	50	60	%
Maximum Output Jitter, short term	t_J	$C_L=15$ pF		±150		ps

Note 1: External crystal device must conform with Pullable Crystal Specifications listed on page 3.

Thermal Characteristics

Parameter	Symbol	Conditions	Min.	Typ.	Max.	Units
Thermal Resistance Junction to Ambient	θ_{JA}	Still air		78		°C/W
	θ_{JA}	1 m/s air flow		70		°C/W
	θ_{JA}	3 m/s air flow		68		°C/W
Thermal Resistance Junction to Case	θ_{JC}			37		°C/W

Package Outline and Package Dimensions (16-pin TSSOP, 4.40 mm Body, 0.65 mm Pitch)

Package dimensions are kept current with JEDEC Publication No. 95

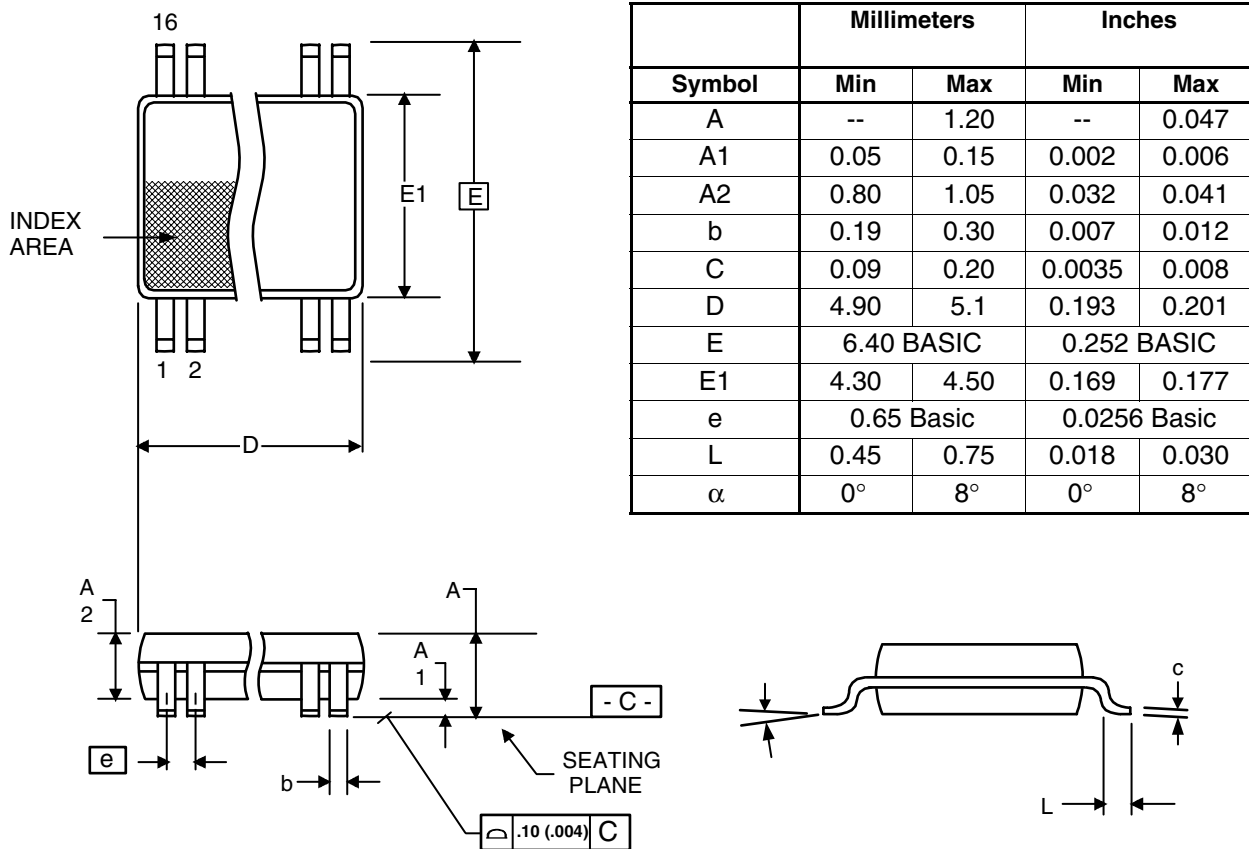

Ordering Information

Part / Order Number	Marking	Shipping Packaging	Package	Temperature
MK3722GLF	MK3722GL	Tubes	16-pin TSSOP	0 to +70° C
MK3722GLFTR	MK3722GL	Tape and Reel	16-pin TSSOP	0 to +70° C

"LF" suffix to the part number are the Pb-Free configuration and are RoHS compliant.

While the information presented herein has been checked for both accuracy and reliability, Integrated Device Technology (IDT) assumes no responsibility for either its use or for the infringement of any patents or other rights of third parties, which would result from its use. No other circuits, patents, or licenses are implied. This product is intended for use in normal commercial applications. Any other applications such as those requiring extended temperature range, high reliability, or other extraordinary environmental requirements are not recommended without additional processing by IDT. IDT reserves the right to change any circuitry or specifications without notice. IDT does not authorize or warrant any IDT product for use in life support devices or critical medical instruments.

IMPORTANT NOTICE AND DISCLAIMER

RENESAS ELECTRONICS CORPORATION AND ITS SUBSIDIARIES (“RENESAS”) PROVIDES TECHNICAL SPECIFICATIONS AND RELIABILITY DATA (INCLUDING DATASHEETS), DESIGN RESOURCES (INCLUDING REFERENCE DESIGNS), APPLICATION OR OTHER DESIGN ADVICE, WEB TOOLS, SAFETY INFORMATION, AND OTHER RESOURCES “AS IS” AND WITH ALL FAULTS, AND DISCLAIMS ALL WARRANTIES, EXPRESS OR IMPLIED, INCLUDING, WITHOUT LIMITATION, ANY IMPLIED WARRANTIES OF MERCHANTABILITY, FITNESS FOR A PARTICULAR PURPOSE, OR NON-INFRINGEMENT OF THIRD-PARTY INTELLECTUAL PROPERTY RIGHTS.

These resources are intended for developers who are designing with Renesas products. You are solely responsible for (1) selecting the appropriate products for your application, (2) designing, validating, and testing your application, and (3) ensuring your application meets applicable standards, and any other safety, security, or other requirements. These resources are subject to change without notice. Renesas grants you permission to use these resources only to develop an application that uses Renesas products. Other reproduction or use of these resources is strictly prohibited. No license is granted to any other Renesas intellectual property or to any third-party intellectual property. Renesas disclaims responsibility for, and you will fully indemnify Renesas and its representatives against, any claims, damages, costs, losses, or liabilities arising from your use of these resources. Renesas' products are provided only subject to Renesas' Terms and Conditions of Sale or other applicable terms agreed to in writing. No use of any Renesas resources expands or otherwise alters any applicable warranties or warranty disclaimers for these products.

(Disclaimer Rev.1.01)

Corporate Headquarters

TOYOSU FORESIA, 3-2-24 Toyosu,
Koto-ku, Tokyo 135-0061, Japan
www.renesas.com

Trademarks

Renesas and the Renesas logo are trademarks of Renesas Electronics Corporation. All trademarks and registered trademarks are the property of their respective owners.

Contact Information

For further information on a product, technology, the most up-to-date version of a document, or your nearest sales office, please visit www.renesas.com/contact-us/.