

The MPC9351 is a 2.5V and 3.3V compatible, PLL based clock generator targeted for high performance clock distribution systems. With output frequencies of up to 200 MHz and a maximum output skew of 150ps, the MPC9351 is an ideal solution for the most demanding clock tree designs. The device offers 9 low-skew clock outputs, each is configurable to support the clocking needs of the various high-performance microprocessors including the PowerQUICC II integrated communication microprocessor. The extended temperature range of the MPC9351 supports telecommunication and networking requirements. The device employs a fully differential PLL design to minimize cycle-to-cycle and long-term jitter.

**Features**

- 9 Outputs LVCMOS PLL Clock Generator
- 25 – 200MHz Output Frequency Range
- Fully Integrated PLL
- 2.5V and 3.3V Compatible
- Compatible to Various Microprocessors Such as PowerQuicc II
- Supports Networking, Telecommunications and Computer Applications
- Configurable Outputs: Divide-by-2, 4 and 8 of VCO Frequency
- LVPECL and LVCMOS Compatible Inputs
- External Feedback Enables Zero-Delay Configurations
- Output Enable/disable and Static Test Mode (PLL Enable/Disable)
- Low Skew Characteristics: Maximum 150ps Output-to-Output
- Cycle-to-Cycle Jitter Max. 22ps RMS
- 32-Lead LQFP Package, Pb-Free
- Ambient Temperature Range -40°C to +85°C
- **For functional replacement use 8T49N285**

**MPC9351**

**LOW VOLTAGE  
2.5 V AND 3.3 V PLL  
CLOCK GENERATOR**

  
**AC SUFFIX  
32-LEAD LQFP PACKAGE  
Pb-FREE PACKAGE  
CASE 873A-03**

**Functional Description**

The MPC9351 utilizes PLL technology to frequency and phase lock its outputs onto an input reference clock. Normal operation of the MPC9351 requires a connection of one of the device outputs to the EXT\_FB input to close the PLL feedback path. The reference clock frequency and the output divider for the feedback path determine the VCO frequency. Both must be selected to match the VCO frequency range. With available output dividers of divide-by-2, divide-by-4 and divide-by-8, the internal VCO of the MPC9351 is running at either 2x, 4x or 8x of the reference clock frequency. The frequency of the QA, QB, QC and QD outputs is either the one-half, one-fourth or one-eighth of the selected VCO frequency and can be configured for each output bank using the FSELA, FSELB, FSELC and FSELD pins, respectively. The available output-to-input frequency ratios are 4:1, 2:1, 1:1, 1:2 and 1:4. The REF\_SEL pin selects the differential LVPECL (PCLK and PCLK) or the LVCMOS compatible reference input (TCLK). The MPC9351 also provides a static test mode when the PLL enable pin (PLL\_EN) is pulled to logic low state. In test mode, the selected input reference clock is routed directly to the output dividers bypassing the PLL. The test mode is intended for system diagnostics, test and debug purposes. This test mode is fully static and the minimum clock frequency specification does not apply. The outputs can be disabled by deasserting the OE pin (logic high state). In PLL mode, deasserting OE causes the PLL to loose lock due to no feedback signal presence at EXT\_FB. Asserting OE will enable the outputs and close the phase locked loop, also enabling the PLL to recover to normal operation. The MPC9351 is fully 2.5 V and 3.3 V compatible and requires no external loop filter components. All inputs except PCLK and PCLK accept LVCMOS signals, while the outputs provide LVCMOS compatible levels with the capability to drive terminated 50 Ω transmission lines. For series terminated transmission lines, each of the MPC9351 outputs can drive one or two traces giving the device an effective fanout of 1:18. The device is packaged in a 7x7 mm<sup>2</sup> 32-lead LQFP package.

**Application Information**

The fully integrated PLL of the MPC9351 allows the low-skew outputs to lock onto a clock input and distribute it with essentially zero propagation delay to multiple components on the board. In zero-delay buffer mode, the PLL minimizes phase offset between the outputs and the reference signal.

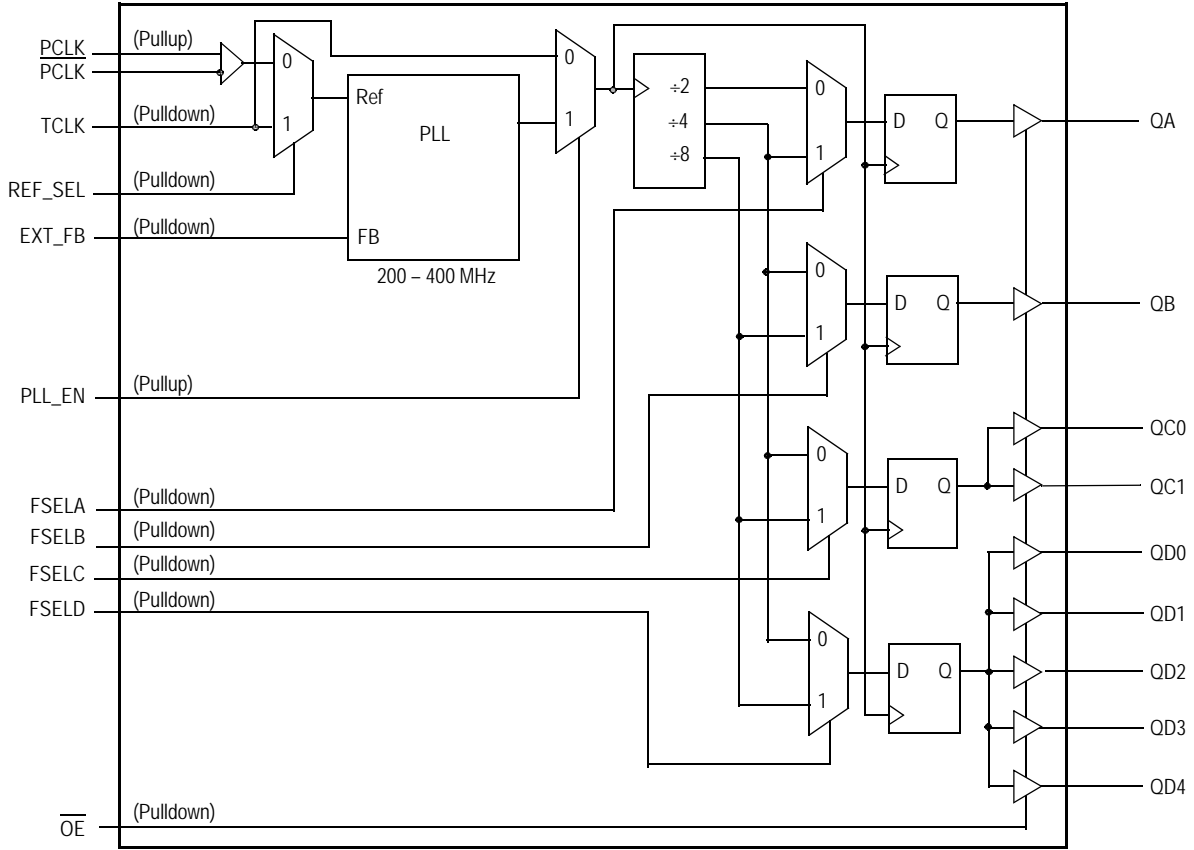

The MPC9351 requires an external RC filter for the analog power supply pin  $V_{CCA}$ . Please see application section for details.

Figure 1. MPC9351 Logic Diagram

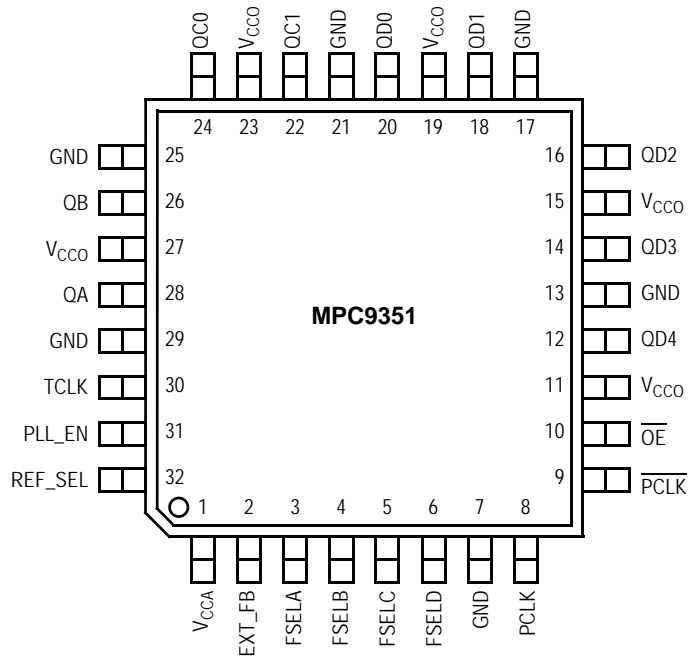

Figure 2. Pinout: 32-Lead Package Pinout (Top View)

**Table 1. Pin Descriptions**

Number	Name	Type	Description
PCLK, $\overline{\text{PCLK}}$	Input	LVPECL	Differential clock reference Low voltage positive ECL input
TCLK	Input	LVC MOS	Single ended reference clock signal or test clock
EXT_FB	Input	LVC MOS	Feedback signal input, connect to a QA, QB, QC, QD output
REF_SEL	Input	LVC MOS	Selects input reference clock
FSELA	Input	LVC MOS	Output A divider selection
FSELB	Input	LVC MOS	Output B divider selection
FSELC	Input	LVC MOS	Outputs C divider selection
FSELD	Input	LVC MOS	Outputs D divider selection
OE	Input	LVC MOS	Output enable/disable
QA	Output	LVC MOS	Bank A clock output
QB	Output	LVC MOS	Bank B clock output
QC0, QC1	Output	LVC MOS	Bank C clock outputs
QD0 – QD4	Output	LVC MOS	Bank D clock outputs
V <sub>CCA</sub>	Supply	V <sub>CC</sub>	Positive power supply for the PLL
V <sub>CC</sub>	Supply	V <sub>CC</sub>	Positive power supply for I/O and core
GND	Supply	Ground	Negative power supply

**Table 2. Function Table**

Control	Default	0	1
REF_SEL	0	Selects PCLK as reference clock	Selects TCLK as reference clock
PLL_EN	1	Test mode with PLL disabled. The input clock is directly routed to the output dividers	PLL enabled. The VCO output is routed to the output dividers
$\overline{\text{OE}}$	0	Outputs enabled	Outputs disabled, PLL loop is open VCO is forced to its minimum frequency
FSELA	0	QA = VCO ÷ 2	QA = VCO ÷ 4
FSELB	0	QB = VCO ÷ 4	QB = VCO ÷ 8
FSELC	0	QC = VCO ÷ 4	QC = VCO ÷ 8
FSELD	0	QD = VCO ÷ 4	QD = VCO ÷ 8

**Table 3. Absolute Maximum Ratings<sup>(1)</sup>**

Symbol	Characteristics	Min	Max	Unit
V <sub>CC</sub>	Supply Voltage	-0.3	4.6	V
V <sub>IN</sub>	DC Input Voltage	-0.3	V <sub>CC</sub> +0.3	V
V <sub>OUT</sub>	DC Output Voltage	-0.3	V <sub>CC</sub> +0.3	V
I <sub>IN</sub>	DC Input Current		±20	mA
I <sub>OUT</sub>	DC Output Current		±50	mA
T <sub>S</sub>	Storage Temperature	-55	150	°C

1. Absolute maximum continuous ratings are those maximum values beyond which damage to the device may occur. Exposure to these conditions or conditions beyond those indicated may adversely affect device reliability. Functional operation under absolute-maximum-rated conditions is not implied.

**Table 4. General Specifications**

Symbol	Characteristics	Min	Typ	Max	Unit	Condition
$V_{TT}$	Output Termination Voltage		$V_{CC} \div 2$		V	
MM	ESD (Machine Model)	200			V	
HBM	ESD (Human Body Model)	2000			V	
LU	Latch-Up	200			mA	
$C_{PD}$	Power Dissipation Capacitance		10		pF	Per output
$C_{IN}$	Input Capacitance		4.0		pF	Inputs

**Table 5. DC Characteristics** ( $V_{CC} = 3.3\text{ V} \pm 5\%$ ,  $T_A = -40^\circ$  to  $85^\circ\text{C}$ )

Symbol	Characteristics	Min	Typ	Max	Unit	Condition
$V_{IH}$	Input High Voltage	2.0		$V_{CC} + 0.3$	V	LVC MOS
$V_{IL}$	Input Low Voltage			0.8	V	LVC MOS
$V_{PP}$	Peak-to-Peak Input Voltage PCLK, $\overline{\text{PCLK}}$	250			mV	LVPECL
$V_{CMR}^{(1)}$	Common Mode Range PCLK, $\overline{\text{PCLK}}$	1.0		$V_{CC} - 0.6$	V	LVPECL
$V_{OH}$	Output High Voltage	2.4			V	$I_{OH} = -24\text{ mA}^{(2)}$
$V_{OL}$	Output Low Voltage			0.55 0.30	V V	$I_{OL} = 24\text{ mA}$ $I_{OL} = 12\text{ mA}$
$Z_{OUT}$	Output Impedance		14–17		$\Omega$	
$I_{IN}$	Input Leakage Current			$\pm 200$	$\mu\text{A}$	$V_{IN} = V_{CC}$ or GND
$I_{CCA}$	Maximum PLL Supply Current		3.0	5.0	mA	$V_{CCA}$ Pin
$I_{CCQ}$	Maximum Quiescent Supply Current			1.0	mA	All $V_{CC}$ Pins

- $V_{CMR}$  (DC) is the crosspoint of the differential input signal. Functional operation is obtained when the crosspoint is within the  $V_{CMR}$  range and the input swing lies within the  $V_{PP}$  (DC) specification.
- The MPC9351 is capable of driving  $50\ \Omega$  transmission lines on the incident edge. Each output drives one  $50\ \Omega$  parallel terminated transmission line to a termination voltage of  $V_{TT}$ . Alternatively, the device drives up to two  $50\ \Omega$  series terminated transmission lines.

**Table 6. AC Characteristics** ( $V_{CC} = 3.3\text{ V} \pm 5\%$ ,  $T_A = -40^\circ$  to  $85^\circ\text{C}$ )<sup>(1)</sup>

Symbol	Characteristics	Min	Typ	Max	Unit	Condition
$f_{ref}$	Input Frequency <div style="display: flex; justify-content: space-between;"> <div style="width: 60%;"></div> <div style="width: 30%;"> <math>\div 2</math> feedback  <math>\div 4</math> feedback  <math>\div 8</math> feedback                      Static test mode                 </div> </div>	100 50 25 0		200 100 50 300	MHz MHz MHz MHz	PLL_EN = 1 PLL_EN = 1 PLL_EN = 1 PLL_EN = 0
$f_{VCO}$	VCO Frequency	200		400	MHz	
$f_{MAX}$	Maximum Output Frequency <div style="display: flex; justify-content: space-between;"> <div style="width: 60%;"></div> <div style="width: 30%;"> <math>\div 2</math> output  <math>\div 4</math> output  <math>\div 8</math> output                 </div> </div>	100 50 25		200 100 50	MHz MHz MHz	
$f_{refDC}$	Reference Input Duty Cycle	25		75	%	
$V_{PP}$	Peak-to-Peak Input Voltage PCLK, $\overline{\text{PCLK}}$	500		1000	mV	LVPECL
$V_{CMR}^{(2)}$	Common Mode Range PCLK, $\overline{\text{PCLK}}$	1.2		$V_{CC} - 0.9$	V	LVPECL
$t_r, t_f$	TCLK Input Rise/Fall Time			1.0	ns	0.8 to 2.0V
$t_{(\varnothing)}$	Propagation Delay (static phase offset) TCLK to EXT_FB PCLK to EXT_FB	-50 +25		+150 +325	ps ps	PLL locked PLL locked

**Table 6. AC Characteristics** ( $V_{CC} = 3.3\text{ V} \pm 5\%$ ,  $T_A = -40^\circ$  to  $85^\circ\text{C}$ )<sup>(1)</sup> (Continued)

Symbol	Characteristics	Min	Typ	Max	Unit	Condition	
$t_{sk(o)}$	Output-to-Output Skew			150	ps		
DC	Output Duty Cycle	100 – 200 MHz	45	50	55	%	
		50 – 100 MHz	47.5	50	52.5	%	
		25 – 50 MHz	48.75	50	51.75	%	
$t_r, t_f$	Output Rise/Fall Time	0.1		1.0	ns	0.55 to 2.4 V	
$t_{PLZ, HZ}$	Output Disable Time			10	ns		
$t_{PZL, ZH}$	Output Enable Time			10	ns		
BW	PLL closed loop bandwidth	÷ 2 feedback		9.0 – 20.0		MHz	–3 db point of PLL transfer characteristic
		÷ 4 feedback		3.0 – 9.5		MHz	
		÷ 8 feedback		1.2 – 2.1		MHz	
$t_{JIT(CC)}$	Cycle-to-cycle jitter Single Output Frequency Configuration		10	22	ps	RMS value	
$t_{JIT(PER)}$	Period Jitter Single Output Frequency Configuration		8.0	15	ps	RMS value	
$t_{JIT(\varnothing)}$	I/O Phase Jitter		4.0 – 17		ps	RMS value	
$t_{LOCK}$	Maximum PLL Lock Time			1.0	ms		

1. AC characteristics apply for parallel output termination of  $50\ \Omega$  to  $V_{TT}$ .
2.  $V_{CMR}$  (AC) is the crosspoint of the differential input signal. Normal AC operation is obtained when the crosspoint is within the  $V_{CMR}$  range and the input swing lies within the  $V_{PP}$  (AC) specification. Violation of  $V_{CMR}$  or  $V_{PP}$  impacts static phase offset  $t_{(\varnothing)}$ .

**Table 7. DC Characteristics** ( $V_{CC} = 2.5\text{ V} \pm 5\%$ ,  $T_A = -40^\circ$  to  $85^\circ\text{C}$ )

Symbol	Characteristics	Min	Typ	Max	Unit	Condition
$V_{IH}$	Input High Voltage	1.7		$V_{CC} + 0.3$	V	LVC MOS
$V_{IL}$	Input Low Voltage			0.7	V	LVC MOS
$V_{PP}$	Peak-to-Peak Input Voltage PCLK, $\overline{PCLK}$	250			mV	LVPECL
$V_{CMR}^{(1)}$	Common Mode Range PCLK, $\overline{PCLK}$	1.0		$V_{CC} - 0.6$	V	LVPECL
$V_{OH}$	Output High Voltage	1.8			V	$I_{OH} = -15\text{ mA}^{(2)}$
$V_{OL}$	Output Low Voltage			0.6	V	$I_{OL} = 15\text{ mA}$
$Z_{OUT}$	Output Impedance		17 – 20		$\Omega$	
$I_{IN}$	Input Leakage Current			$\pm 200$	$\mu\text{A}$	$V_{IN} = V_{CC}$ or GND
$C_{IN}$	Input Capacitance		4.0		pF	
$C_{PD}$	Power Dissipation Capacitance		10		pF	Per Output
$I_{CCA}$	Maximum PLL Supply Current		3.0	5.0	mA	$V_{CCA}$ Pin
$I_{CCQ}$	Maximum Quiescent Supply Current			1.0	mA	All $V_{CC}$ Pins

1.  $V_{CMR}$  (DC) is the crosspoint of the differential input signal. Functional operation is obtained when the crosspoint is within the  $V_{CMR}$  range and the input swing lies within the  $V_{PP}$  (DC) specification.
2. The MPC9351 is capable of driving  $50\ \Omega$  transmission lines on the incident edge. Each output drives one  $50\ \Omega$  parallel terminated transmission line to a termination voltage of  $V_{TT}$ . Alternatively, the device drives up to two  $50\ \Omega$  series terminated transmission lines per output.

**Table 8. AC Characteristics** ( $V_{CC} = 2.5\text{ V} \pm 5\%$ ,  $T_A = -40^\circ$  to  $85^\circ\text{C}$ )<sup>(1)</sup>

Symbol	Characteristics	Min	Typ	Max	Unit	Condition	
$f_{ref}$	Input Frequency	$\div 2$ feedback		200	MHz		
		$\div 4$ feedback	100	100	MHz		
		$\div 8$ feedback	25	50	MHz		
$f_{VCO}$	VCO Frequency	200		400	MHz		
$f_{MAX}$	Maximum Output Frequency	$\div 2$ output		200	MHz		
		$\div 4$ output	100	100	MHz		
		$\div 8$ output	25	50	MHz		
$f_{refDC}$	Reference Input Duty Cycle	25		75	%		
$V_{PP}$	Peak-to-Peak Input Voltage PCLK, $\overline{\text{PCLK}}$	500		1000	mV	LVPECL	
$V_{CMR}$ <sup>(2)</sup>	Common Mode Range PCLK, $\overline{\text{PCLK}}$	1.2		$V_{CC} - 0.6$	V	LVPECL	
$t_r, t_f$	TCLK Input Rise/Fall Time			1.0	ns	0.7 to 1.7 V	
$t_{(\varnothing)}$	Propagation Delay (static phase offset) TCLK to EXT_FB PCLK to EXT_FB		-100	+100	ps	PLL locked	
			0	+300	ps	PLL locked	
$t_{sk(o)}$	Output-to-Output Skew			150	ps		
DC	Output Duty Cycle	100 – 200 MHz	45	50	55	%	
		50 – 100 MHz	47.5	50	52.5	%	
		25 – 50 MHz	48.75	50	51.75	%	
$t_r, t_f$	Output Rise/Fall Time	0.1		1.0	ns	0.6 to 1.8 V	
$t_{PLZ, HZ}$	Output Disable Time			12	ns		
$t_{PZL, ZH}$	Output Enable Time			12	ns		
BW	PLL closed loop bandwidth	$\div 2$ feedback		4.0 – 15.0	MHz	-3 dB point of PLL transfer characteristic	
		$\div 4$ feedback		2.0 – 7.0	MHz		
		$\div 8$ feedback		0.7 – 2.0	MHz		
$t_{JIT(CC)}$	Cycle-to-cycle jitter Single Output Frequency Configuration		10	22	ps	RMS value	
$t_{JIT(PER)}$	Period Jitter Single Output Frequency Configuration		8.0	15	ps	RMS value	
$t_{JIT(\varnothing)}$	I/O Phase Jitter		6.0 – 25		ps	RMS value	
$t_{LOCK}$	Maximum PLL Lock Time			1.0	ms		

- AC characteristics apply for parallel output termination of  $50\ \Omega$  to  $V_{TT}$ .
- $V_{CMR}$  (AC) is the crosspoint of the differential input signal. Normal AC operation is obtained when the crosspoint is within the  $V_{CMR}$  range and the input swing lies within the  $V_{PP}$  (AC) specification. Violation of  $V_{CMR}$  or  $V_{PP}$  impacts static phase offset  $t_{(\varnothing)}$ .

APPLICATIONS INFORMATION

Programming the MPC9351

The MPC9351 clock driver outputs can be configured into several divider modes; in addition, the external feedback of the device allows for flexibility in establishing various input to output frequency relationships. The output divider of the four output groups allows the user to configure the outputs into 1:1, 2:1, 4:1 and 4:2:1 frequency ratios. The use of even dividers ensures that the output duty cycle is always 50%. Table 9 illustrates the various output configurations. The table describes the outputs using the input clock frequency CLK as a reference.

The output division settings establish the output relationship. In addition, it must be ensured that the VCO will be stable given the frequency of the outputs desired. The feedback frequency should be used to situate the VCO into a frequency range in which the PLL will be stable. The design of the PLL supports output frequencies from 25MHz to 200MHz, while the VCO frequency range is specified from 200MHz to 400MHz and should not be exceeded for stable operation.

Table 9. Output Frequency Relationship<sup>(1)</sup> for an Example Configuration

Inputs				Outputs			
FSELA	FSELB	FSELC	FSELD	QA	QB	QC	QD
0	0	0	0	2 * CLK	CLK	CLK	CLK
0	0	0	1	2 * CLK	CLK	CLK	CLK ÷ 2
0	0	1	0	4 * CLK	2 * CLK	CLK	2 * CLK
0	0	1	1	4 * CLK	2 * CLK	CLK	CLK
0	1	0	0	2 * CLK	CLK ÷ 2	CLK	CLK
0	1	0	1	2 * CLK	CLK ÷ 2	CLK	CLK ÷ 2
0	1	1	0	4 * CLK	CLK	CLK	2 * CLK
0	1	1	1	4 * CLK	CLK	CLK	CLK
1	0	0	0	CLK	CLK	CLK	CLK
1	0	0	1	CLK	CLK	CLK	CLK ÷ 2
1	0	1	0	2 * CLK	2 * CLK	CLK	2 * CLK
1	0	1	1	2 * CLK	2 * CLK	CLK	CLK
1	1	0	0	CLK	CLK ÷ 2	CLK	CLK
1	1	0	1	CLK	CLK ÷ 2	CLK	CLK ÷ 2
1	1	1	0	2 * CLK	CLK	CLK	2 * CLK
1	1	1	1	2 * CLK	CLK	CLK	CLK

1. Output frequency relationship with respect to input reference frequency CLK. QC1 is connected to EXT\_FB. More frequency ratios are available by the connection of QA to the feedback input (EXT\_FB).

Using the MPC9351 in Zero-Delay Applications

Nested clock trees are typical applications for the MPC9351. For these applications, the MPC9351 offers a differential LVPECL clock input pair as a PLL reference. This allows for the use of differential LVPECL primary clock distribution devices such as the Freescale MC100EP111 or MC10EP222, taking advantage of its superior low-skew performance. Clock trees using LVPECL for clock distribution, and the MPC9351 as LVCMOS PLL fanout buffer with zero insertion delay, will show significantly lower clock skew than clock distributions developed from CMOS fanout buffers.

The external feedback option of the MPC9351 PLL allows for its use as a zero-delay buffer. The PLL aligns the feedback clock output edge with the clock input reference edge and virtually eliminates the propagation delay through the device.

The remaining insertion delay (skew error) of the MPC9351 in zero-delay applications is measured between the reference clock input and any output. This effective delay consists of the static phase offset (SPO or  $t_{(\phi)}$ ), I/O jitter ( $t_{JIT(\phi)}$ , phase or long-term jitter), feedback path delay and

the output-to-output skew ( $t_{SK(O)}$ ) relative to the feedback output.

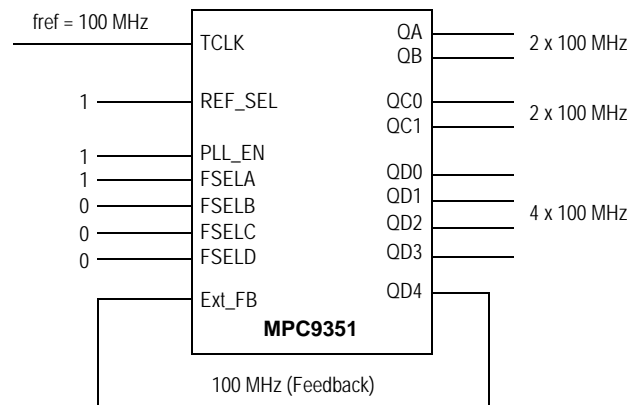

Figure 3. MPC9351 Zero-Delay Configuration (Feedback of QD4)

**Calculation of Part-to-Part Skew**

The MPC9351 zero-delay buffer supports applications where critical clock signal timing can be maintained across several devices. If the reference clock inputs (TCLK or PCLK) of two or more MPC9351 are connected together, the maximum overall timing uncertainty from the common TCLK input to any output is:

$$t_{SK(PP)} = t_{(\varnothing)} + t_{SK(O)} + t_{PD, LINE(FB)} + t_{JIT(\varnothing)} \cdot CF$$

This maximum timing uncertainty consist of 4 components: static phase offset, output skew, feedback board trace delay and I/O (phase) jitter:

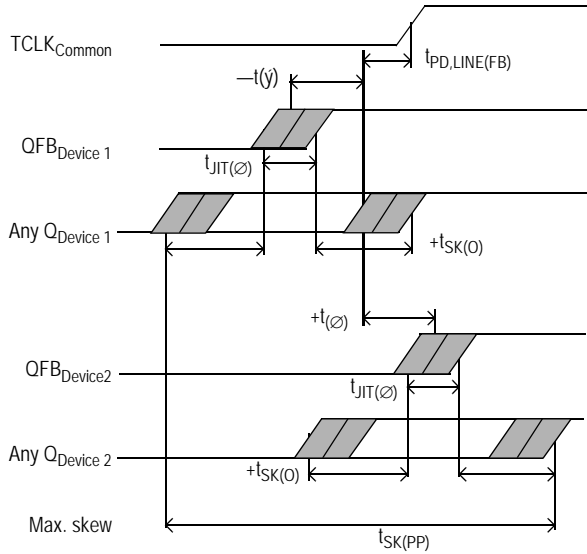

**Figure 4. MPC9351 Maximum Device-to-Device Skew**

Due to the statistical nature of I/O jitter, a RMS value (1 σ) is specified. I/O jitter numbers for other confidence factors (CF) can be derived from Table 10.

**Table 10. Confidence Factor CF**

CF	Probability of Clock Edge within the Distribution
± 1σ	0.68268948
± 2σ	0.95449988
± 3σ	0.99730007
± 4σ	0.99993663
± 5σ	0.99999943
± 6σ	0.99999999

The feedback trace delay is determined by the board layout and can be used to fine-tune the effective delay through each device. In the following example calculation, an I/O jitter confidence factor of 99.7% (± 3σ) is assumed, resulting in a worst case timing uncertainty from input to any output of -251 ps to 351 ps relative to TCLK (VCC = 3.3 V and fVCO = 400 MHz):

$$t_{SK(PP)} = [-50 \text{ ps} \dots 150 \text{ ps}] + [-150 \text{ ps} \dots 150 \text{ ps}] + [(17 \text{ ps} \cdot -3) \dots (17 \text{ ps} \cdot 3)] + t_{PD, LINE(FB)}$$

$$t_{SK(PP)} = [-251 \text{ ps} \dots 351 \text{ ps}] + t_{PD, LINE(FB)}$$

Above equation uses the maximum I/O jitter number shown in the AC characteristic table for VCC = 3.3 V (17 ps RMS). I/O jitter is frequency dependant with a maximum at the lowest VCO frequency (200 MHz for the MPC9351). Applications using a higher VCO frequency exhibit less I/O jitter than the AC characteristic limit. The I/O jitter characteristics in Figure 5 and Figure 6 can be used to derive a smaller I/O jitter number at the specific VCO frequency, resulting in tighter timing limits in zero-delay mode and for part-to-part skew (tSK(PP)).

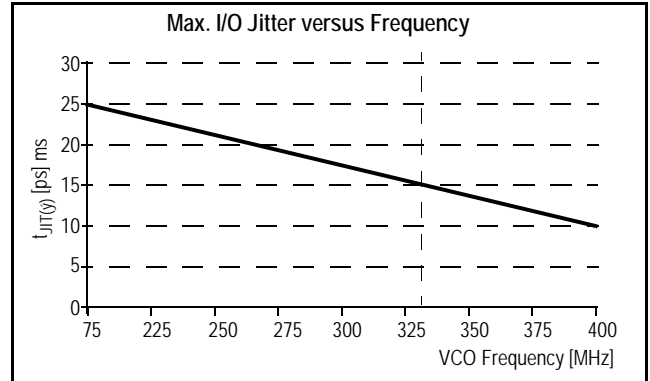

**Figure 5. Maximum I/O Jitter (RMS) versus Frequency for VCC = 2.5 V**

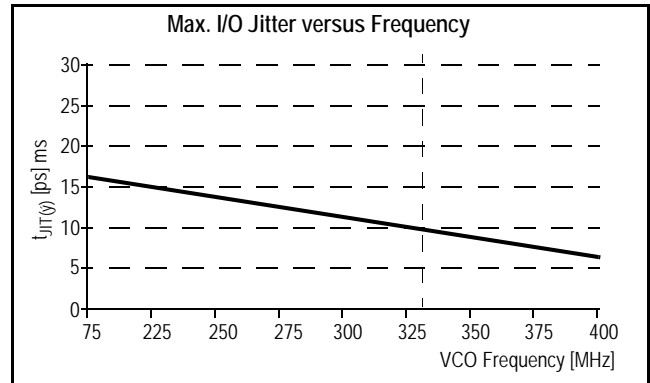

**Figure 6. Maximum I/O Jitter (RMS) versus Frequency for VCC = 3.3 V**

**Power Supply Filtering**

The MPC9351 is a mixed analog/digital product. Its analog circuitry is naturally susceptible to random noise, especially if this noise is seen on the power supply pins. Noise on the VCCA (PLL) power supply impacts the device characteristics, for instance, I/O jitter. The MPC9351 provides separate power supplies for the output buffers (VCC) and the phase-locked loop (VCCA) of the device. The purpose of this design technique is to isolate the high switching noise digital outputs from the relatively sensitive internal analog phase-locked loop. In a digital system environment, where it is more difficult to minimize noise on the power supplies, a second level of isolation may be required. The simple but effective form of isolation is a power supply filter on the VCCA pin for the MPC9351. Figure 7 illustrates a typical power supply filter scheme. The MPC9351 frequency and phase stability is most susceptible to noise with spectral content in



the 100 kHz to 20MHz range; therefore, the filter should be designed to target this range. The key parameter that needs to be met in the final filter design is the DC voltage drop across the series filter resistor ( $R_F$ ). From the data sheet, the  $I_{CCA}$  current (the current sourced through the  $V_{CCA}$  pin) is typically 3mA (5mA maximum), assuming that a minimum of 2.325V ( $V_{CC} = 3.3V$  or  $V_{CC} = 2.5V$ ) must be maintained on the  $V_{CCA}$  pin. The resistor  $R_F$  shown in Figure 7 must have a resistance of 270  $\Omega$  ( $V_{CC} = 3.3 V$ ) or 9–10  $\Omega$  ( $V_{CC} = 2.5 V$ ) to meet the voltage drop criteria.

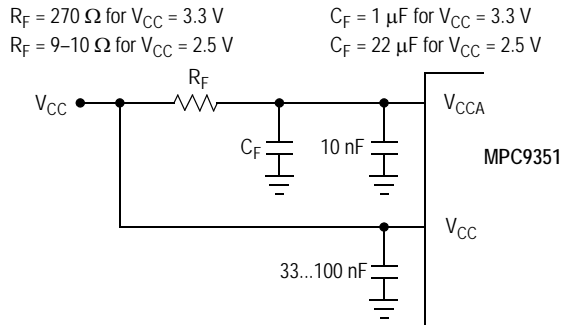

Figure 7.  $V_{CCA}$  Power Supply Filter

The minimum values for  $R_F$  and the filter capacitor  $C_F$  are defined by the required filter characteristics. The RC filter should provide an attenuation greater than 40 dB for noise whose spectral content is above 100 kHz. In the example RC filter shown in Figure 7, the filter cut-off frequency is around 3–5 kHz, and the noise attenuation at 100 kHz is better than 42dB.

As the noise frequency crosses the series resonant point of an individual capacitor, its overall impedance begins to look inductive, and thus, increases with increasing frequency. The parallel capacitor combination shown ensures that a low impedance path to ground exists for frequencies well above the bandwidth of the PLL. Although the MPC9351 has several design features to minimize the susceptibility to power supply noise (isolated power and grounds and fully differential PLL), there still may be applications in which overall performance is being degraded due to system power supply noise. The power supply filter schemes discussed in this section should be adequate to eliminate power supply noise related problems in most designs.

**Driving Transmission Lines**

The MPC9351 clock driver was designed to drive high-speed signals in a terminated transmission line environment. To provide the optimum flexibility to the user, the output drivers were designed to exhibit the lowest impedance possible. With an output impedance of less than 20 $\Omega$ , the drivers can drive either parallel or series terminated transmission lines. For more information on transmission lines the reader is referred to Freescale application note AN1091. In most high performance clock networks, point-to-point distribution of signals is the method of choice. In a point-to-point scheme, either series terminated or parallel terminated transmission lines can be used. The parallel technique terminates the signal at the end of the line with a 50 $\Omega$  resistance to  $V_{CC} \div 2$ .

This technique draws a fairly high level of DC current and thus only a single terminated line can be driven by each output of the MPC9351 clock driver. For the series terminated case, however, there is no DC current draw, thus the outputs can drive multiple series terminated lines in parallel. Figure 8 illustrates an output driving a single series terminated line versus two series terminated lines in parallel. When taken to its extreme, the fanout of the MPC9351 clock driver is effectively doubled due to its capability to drive multiple lines.

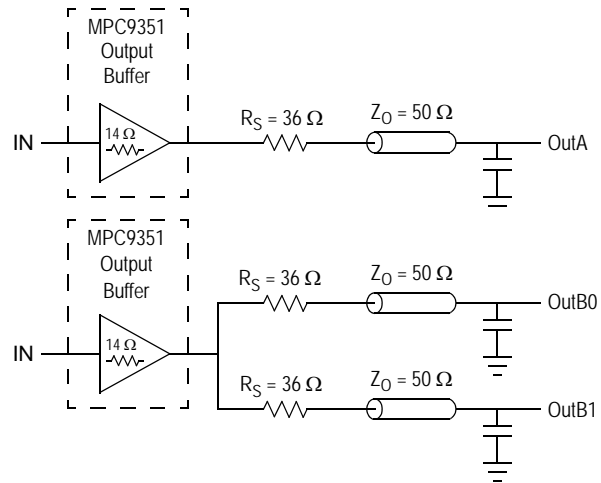

Figure 8. Single versus Dual Transmission Lines

The waveform plots in Figure 9 show the simulation results of an output driving a single line versus two lines. In both cases, the drive capability of the MPC9351 output buffer is more than sufficient to drive 50 $\Omega$  transmission lines on the incident edge. Note from the delay measurements in the simulations, a delta of only 43ps exists between the two differently loaded outputs. This suggests that dual line driving need not be used exclusively to maintain the tight output-to-output skew of the MPC9351. The output waveform in Figure 9 shows a step in the waveform. This step is caused by the impedance mismatch seen looking into the driver. The parallel combination of the 36 $\Omega$  series resistor plus the output impedance does not match the parallel combination of the line impedances. The voltage wave launched down the two lines will equal:

$$V_L = V_S (Z_0 \div (R_S + R_0 + Z_0))$$

$$Z_0 = 50 \Omega \parallel 50 \Omega$$

$$R_S = 36 \Omega \parallel 36 \Omega$$

$$R_0 = 14 \Omega$$

$$V_L = 3.0 (25 \div (18 + 17 + 25))$$

$$= 1.31 V$$

At the load end, the voltage will double, due to the near unity reflection coefficient, to 2.6V. It will then increment towards the quiescent 3.0V in steps separated by one round trip delay (in this case 4.0ns).

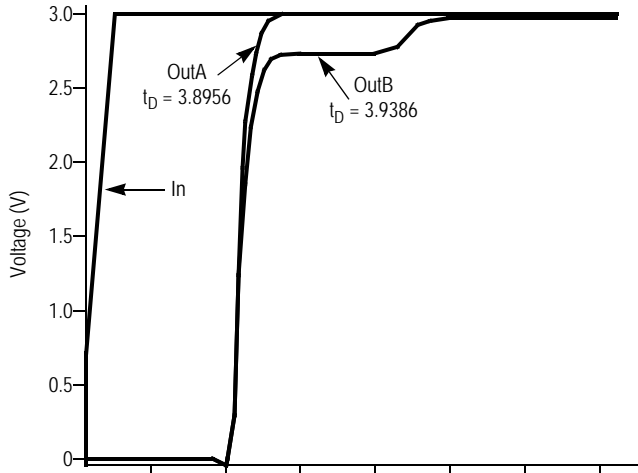

Figure 9. Single versus Dual Waveforms

Since this step is well above the threshold region it will not cause any false clock triggering; however, designers may be uncomfortable with unwanted reflections on the line. To better match the impedances when driving multiple lines, the situation in Figure 10 should be used. In this case, the series terminating resistors are reduced such that when the parallel combination is added to the output buffer impedance, the line impedance is perfectly matched.

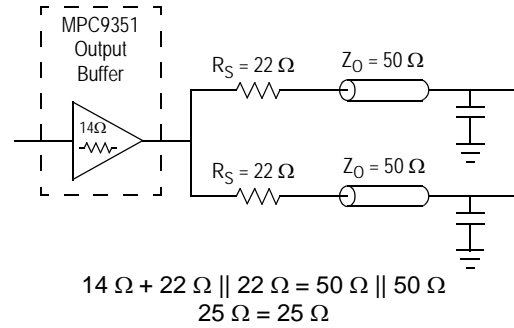

Figure 10. Optimized Dual Line Termination

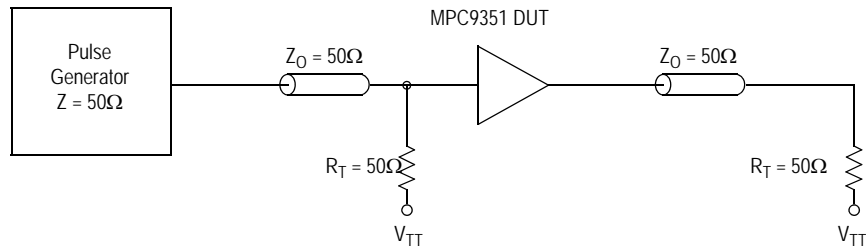

Figure 11. CLK MPC9351 AC Test Reference for  $V_{CC} = 3.3\text{ V}$  and  $V_{CC} = 2.5\text{ V}$

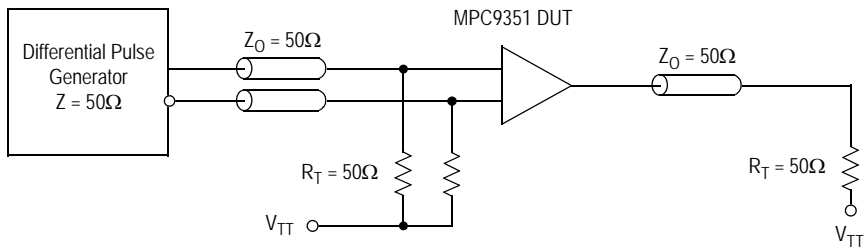

Figure 12. PCLK MPC9351 AC Test Reference

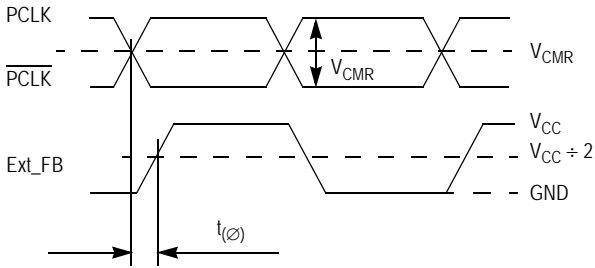

Figure 13. Propagation Delay ( $t_{PD}$ , static phase offset) Test Reference

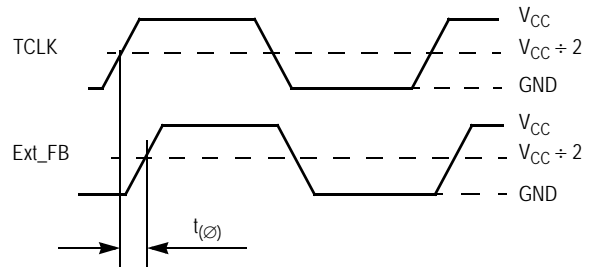
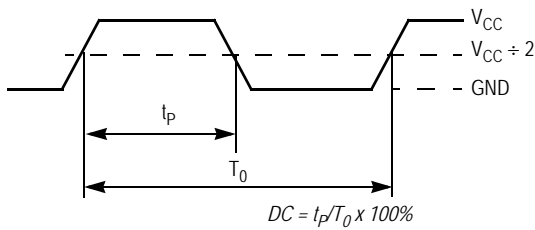
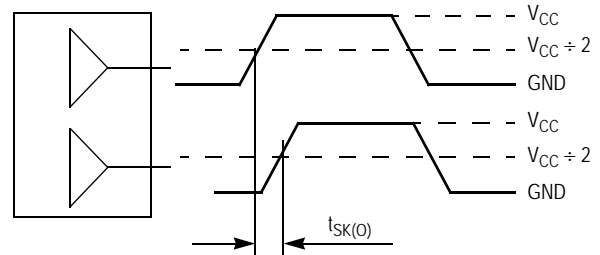

Figure 14. Propagation Delay ( $t_{PD}$ ) Test Reference



The time from the PLL controlled edge to the non-controlled edge, divided by the time between PLL controlled edges, expressed as a percentage.

Figure 15. Output Duty Cycle (DC)



The pin-to-pin skew is defined as the worst case difference in propagation delay between any similar delay path within a single device.

Figure 16. Output-to-Output Skew  $t_{SK(O)}$

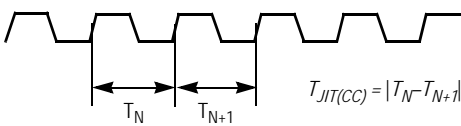

The variation in cycle time of a signal between adjacent cycles, over a random sample of adjacent cycle pairs.

Figure 17. Cycle-to-Cycle Jitter

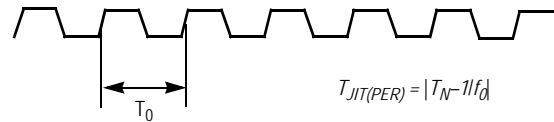

The deviation in cycle time of a signal with respect to the ideal period over a random sample of cycle.s

Figure 18. Period Jitter

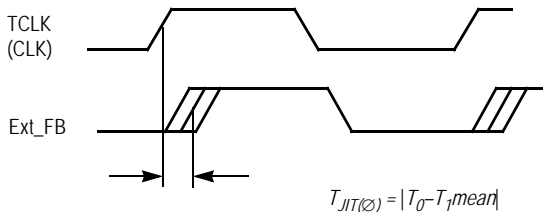

The deviation in  $t_0$  for a controlled edge with respect to a  $t_0$  mean in a random sample of cycles.

Figure 19. I/O Jitter

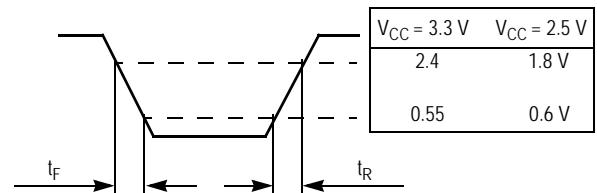
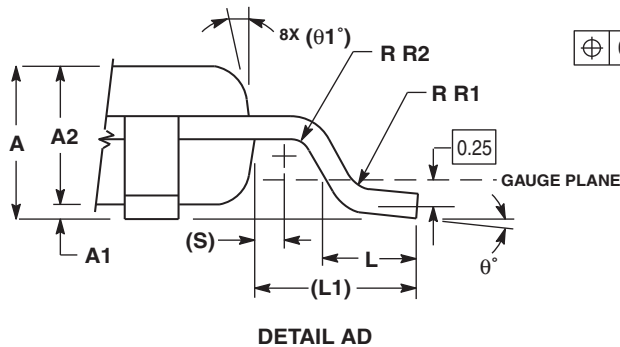
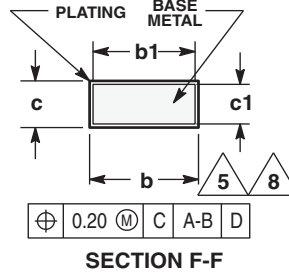
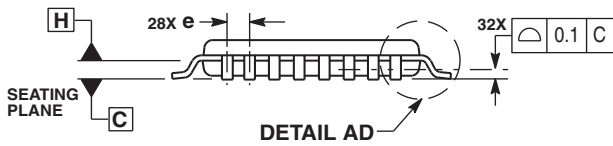
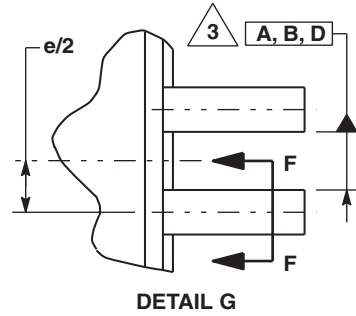
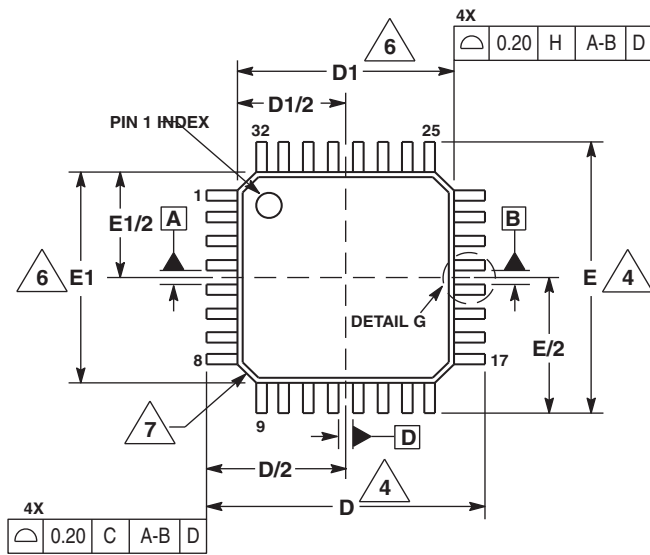

Figure 20. Transition Time Test Reference

PACKAGE DIMENSIONS



- NOTES:
1. DIMENSIONS ARE IN MILLIMETERS.
  2. INTERPRET DIMENSIONS AND TOLERANCES PER ASME Y14.5M, 1994.
  3. DATUMS A, B, AND D TO BE DETERMINED AT DATUM PLANE H.
  4. DIMENSIONS D AND E TO BE DETERMINED AT SEATING PLANE C.
  5. DIMENSION b DOES NOT INCLUDE DAMBAR PROTRUSION. ALLOWABLE DAMBAR PROTRUSION SHALL NOT CAUSE THE LEAD WIDTH TO EXCEED THE MAXIMUM b DIMENSION BY MORE THAN 0.08-mm. DAMBAR CANNOT BE LOCATED ON THE LOWER RADIUS OR THE FOOT. MINIMUM SPACE BETWEEN PROTRUSION AND ADJACENT LEAD OR PROTRUSION: 0.07-mm.
  6. DIMENSIONS D1 AND E1 DO NOT INCLUDE MOLD PROTRUSION. ALLOWABLE PROTRUSION IS 0.25-mm PER SIDE. D1 AND E1 ARE MAXIMUM PLASTIC BODY SIZE DIMENSIONS INCLUDING MOLD MISMATCH.
  7. EXACT SHAPE OF EACH CORNER IS OPTIONAL.
  8. THESE DIMENSIONS APPLY TO THE FLAT SECTION OF THE LEAD BETWEEN 0.1-mm AND 0.25-mm FROM THE LEAD TIP.

DIM	MILLIMETERS	
	MIN	MAX
A	1.40	1.60
A1	0.05	0.15
A2	1.35	1.45
b	0.30	0.45
b1	0.30	0.40
c	0.09	0.20
c1	0.09	0.16
D	9.00 BSC	
D1	7.00 BSC	
e	0.80 BSC	
E	9.00 BSC	
E1	7.00 BSC	
L	0.50	0.70
L1	1.00 REF	
q	0°	7°
q1	12 REF	
R1	0.08	0.20
R2	0.08	---
S	0.20 REF	

CASE 873A-03  
ISSUE B  
LQFP PLASTIC PACKAGE

## Revision History Sheet

<b>Rev</b>	<b>Table</b>	<b>Page</b>	<b>Description of Change</b>	<b>Date</b>
7		1	NRND – Not Recommend for New Designs	1/7/2013
7		1	Removed replacement part from features list.	1/31/2013
7		1	Removed NRND and updated data sheet format	3/18/15
7		1	Product Discontinuation Notice - Last time buy expires September 7, 2016. PDN N-16-02	3/14/16



## IMPORTANT NOTICE AND DISCLAIMER

RENESAS ELECTRONICS CORPORATION AND ITS SUBSIDIARIES (“RENESAS”) PROVIDES TECHNICAL SPECIFICATIONS AND RELIABILITY DATA (INCLUDING DATASHEETS), DESIGN RESOURCES (INCLUDING REFERENCE DESIGNS), APPLICATION OR OTHER DESIGN ADVICE, WEB TOOLS, SAFETY INFORMATION, AND OTHER RESOURCES “AS IS” AND WITH ALL FAULTS, AND DISCLAIMS ALL WARRANTIES, EXPRESS OR IMPLIED, INCLUDING, WITHOUT LIMITATION, ANY IMPLIED WARRANTIES OF MERCHANTABILITY, FITNESS FOR A PARTICULAR PURPOSE, OR NON-INFRINGEMENT OF THIRD-PARTY INTELLECTUAL PROPERTY RIGHTS.

These resources are intended for developers who are designing with Renesas products. You are solely responsible for (1) selecting the appropriate products for your application, (2) designing, validating, and testing your application, and (3) ensuring your application meets applicable standards, and any other safety, security, or other requirements. These resources are subject to change without notice. Renesas grants you permission to use these resources only to develop an application that uses Renesas products. Other reproduction or use of these resources is strictly prohibited. No license is granted to any other Renesas intellectual property or to any third-party intellectual property. Renesas disclaims responsibility for, and you will fully indemnify Renesas and its representatives against, any claims, damages, costs, losses, or liabilities arising from your use of these resources. Renesas' products are provided only subject to Renesas' Terms and Conditions of Sale or other applicable terms agreed to in writing. No use of any Renesas resources expands or otherwise alters any applicable warranties or warranty disclaimers for these products.

(Disclaimer Rev.1.01 Jan 2024)

### Corporate Headquarters

TOYOSU FORESIA, 3-2-24 Toyosu,  
Koto-ku, Tokyo 135-0061, Japan  
[www.renesas.com](http://www.renesas.com)

### Trademarks

Renesas and the Renesas logo are trademarks of Renesas Electronics Corporation. All trademarks and registered trademarks are the property of their respective owners.

### Contact Information

For further information on a product, technology, the most up-to-date version of a document, or your nearest sales office, please visit [www.renesas.com/contact-us/](http://www.renesas.com/contact-us/).