

The MPC9608 is a 3.3 V compatible, 1:10 PLL based zero-delay buffer. With a very wide frequency range and low output skew the MPC9608 is targeted for high performance and mid-range clock tree designs.

**Features**

- 1:10 outputs LVCMOS zero-delay buffer
- Single 3.3 V supply
- Supports a clock I/O frequency range of 12.5 to 200 MHz
- Selectable divide-by-two for one output bank
- Synchronous output enable control (CLK\_STOP)
- Output tristate control (output high impedance)
- PLL bypass mode for low frequency system test purpose
- Supports networking, telecommunications and computer applications
- Supports a variety of microprocessors and controllers
- Compatible to PowerQuicc I and II
- Ambient Temperature Range -40°C to +85°C
- 32-lead Pb-free Package Available
- **For functional replacement use 2308-2HDCG**

The MPC9608 uses an internal PLL and an external feedback path to lock its low-skew clock output phase to the reference clock phase, providing virtually zero propagation delay. This enables nested clock designs with near-zero insertion delay. Designs using the MPC9608 as PLL fanout buffer will show significantly lower clock skew than clock distributions developed from traditional fanout buffers. The device offers one reference clock input and two banks of 5 outputs for clock fanout. The input frequency and phase is reproduced by the PLL and provided at the outputs. A selectable frequency divider sets the bank B outputs to generate either an identical copy of the bank A clocks or one half of the bank A clock frequency. Both output banks remain synchronized to the input reference for both bank B configurations.


Outputs are only disabled or enabled when the outputs are already in logic low state (CLK\_STOP). For system test and diagnosis, the MPC9608 outputs can also be set to high-impedance state by connecting OE to logic high level. Additionally, the device provides a PLL bypass mode for low frequency test purpose. In PLL bypass mode, the minimum frequency and static phase offset specification do not apply.

CLK\_STOP and OE do not affect the PLL feedback output (QFB) and down stream clocks can be disabled without the internal PLL losing lock.


The MPC9608 is fully 3.3 V compatible and requires no external components for the internal PLL. All inputs accept LVCMOS signals while the outputs provide LVCMOS compatible levels with the capability to drive terminated 50 Ω transmission lines on the incident edge. For series terminated transmission lines, each of the MPC9608 outputs can drive one or two traces giving the devices an effective fanout of 1:20. The device is packaged in a 7x7 mm<sup>2</sup> 32-lead LQFP package.

**MPC9608**

**LOW VOLTAGE 3.3 V  
LVCMOS 1:10 ZERO-DELAY  
CLOCK BUFFER**



**FA SUFFIX  
32-LEAD LQFP PACKAGE  
CASE 873A-03**



**AC SUFFIX  
32-LEAD LQFP PACKAGE  
Pb-FREE PACKAGE  
CASE 873A-03**

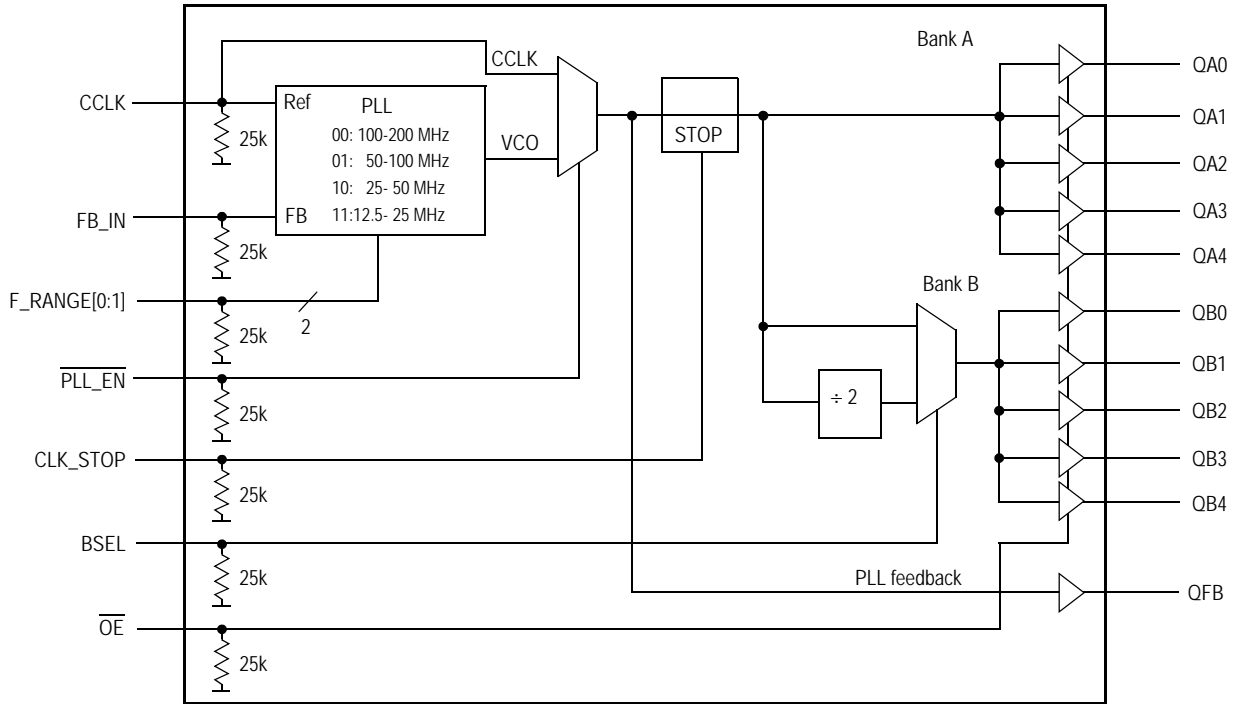


Figure 1. MPC9608 Logic Diagram

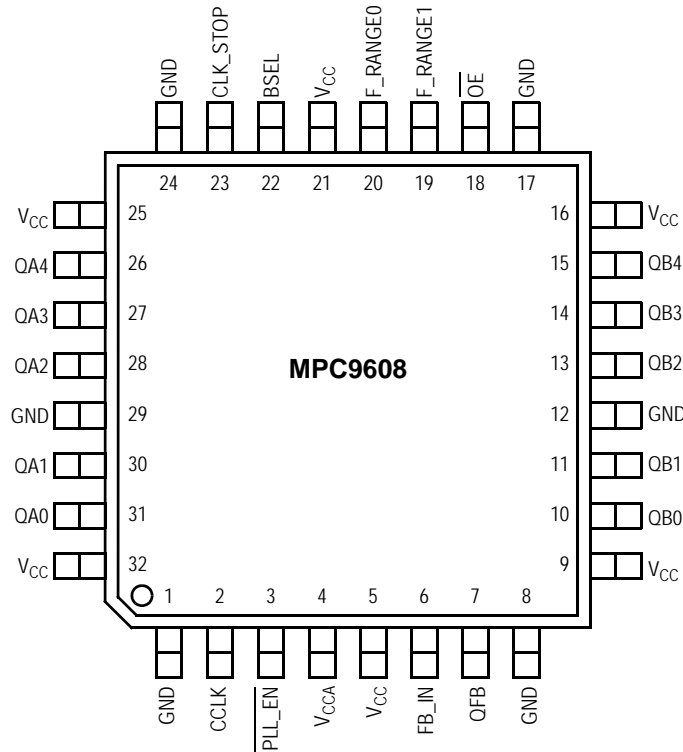


Figure 2. MPC9608 32-Lead Package Pinout (Top View)

**Table 1. Pin Configuration**

Pin	I/O	Type	Function
CCLK	Input	LVC MOS	PLL reference clock signal
FB_IN	Input	LVC MOS	PLL feedback signal input, connect to a QFB output
F_RANGE[0:1]	Input	LVC MOS	PLL frequency range select
BSEL	Input	LVC MOS	Frequency divider select for bank B outputs
PLL_EN	Input	LVC MOS	PLL enable/disable
OE	Input	LVC MOS	Output enable/disable (high-impedance tristate)
CLK_STOP	Input	LVC MOS	Synchronous clock enable/stop
QA0-4, QB0-4	Output	LVC MOS	Clock outputs
QFB	Output	LVC MOS	PLL feedback signal output. Connect to FB_IN
GND	Supply	Ground	Negative power supply
V <sub>CCA</sub>	Supply	V <sub>CC</sub>	PLL positive power supply (analog power supply). The MPC9608 requires an external RC filter for the analog power supply pin V <sub>CCA</sub> . Refer to the Applications Information section for details.
V <sub>CC</sub>	Supply	V <sub>CC</sub>	Positive power supply for I/O and core

**Table 2. Function Table**

Control	Default	0	1
F_RANGE[0:1]	00	PLL frequency range. Refer to <a href="#">Table 3. Clock Frequency Configuration for QFB Connected to FB_INT</a>	
BSEL	0	$f_{QB0-4} = f_{QA0-4}$	$f_{QB0-4} = f_{QA0-4} \div 2$
CLK_STOP	0	Outputs enabled	Outputs synchronously stopped in logic low state
OE	0	Outputs enabled (active)	Outputs disabled (high-impedance state), independent on CLK_STOP. Applying OE = 1 and PLL_EN = 1 resets the device. The PLL feedback output QFB is not affected by OE.
PLL_EN	0	Normal operation mode with PLL enabled.	Test mode with PLL disabled. CCLK is substituted for the internal VCO output. MPC9608 is fully static and no minimum frequency limit applies. All PLL related AC characteristics are not applicable. Applying OE = 1 and PLL_EN = 1 resets the device.

**Table 3. Clock Frequency Configuration for QFB Connected to FB\_IN**

F_RANGE[0]	F_RANGE[1]	BSEL	f <sub>REF</sub> (CCLK) range [MHz]	QA0-QA4		QB0-B4		QFB
				Ratio	f <sub>QA0-4</sub> [MHz]	Ratio	f <sub>QB0-4</sub> [MHz]	
0	0	0	100.0 – 200.0	f <sub>REF</sub>	100.0 – 200.0	f <sub>REF</sub>	100.0 – 200.0	f <sub>REF</sub>
		1				f <sub>REF</sub> ÷ 2	50.0 – 25.0	f <sub>REF</sub>
0	1	0	50.0 – 100.0	f <sub>REF</sub>	50.0 – 100.0	f <sub>REF</sub>	50.0 – 100.0	f <sub>REF</sub>
		1				f <sub>REF</sub> ÷ 2	25.0 – 50.0	f <sub>REF</sub>
1	0	0	25.0 – 50.0	f <sub>REF</sub>	25.0 – 50.0	f <sub>REF</sub>	25.0 – 50.0	f <sub>REF</sub>
		1				f <sub>REF</sub> ÷ 2	12.5 – 25.0	f <sub>REF</sub>
1	1	0	12.5 – 25.0	f <sub>REF</sub>	12.5 – 25	f <sub>REF</sub>	12.5 – 25.0	f <sub>REF</sub>
		1				f <sub>REF</sub> ÷ 2	6.25 – 12.5	f <sub>REF</sub>

**Table 4. General Specifications**

Symbol	Characteristics	Min	Typ	Max	Unit	Condition
V <sub>TT</sub>	Output termination voltage		V <sub>CC</sub> ÷ 2		V	
MM	ESD protection (Machine model)	200			V	
HBM	ESD protection (Human body model)	2000			V	
LU	Latch-up immunity	200			mA	
C <sub>PD</sub>	Power dissipation capacitance		10		pF	Per output
C <sub>IN</sub>	Input capacitance		4.0		pF	Inputs

**Table 5. Absolute Maximum Ratings<sup>(1)</sup>**

Symbol	Characteristics	Min	Max	Unit	Condition
V <sub>CC</sub>	Supply Voltage	-0.3	3.6	V	
V <sub>IN</sub>	DC Input Voltage	-0.3	V <sub>CC</sub> + 0.3	V	
V <sub>OUT</sub>	DC Output Voltage	-0.3	V <sub>CC</sub> + 0.3	V	
I <sub>IN</sub>	DC Input Current		±20	mA	
I <sub>OUT</sub>	DC Output Current		±50	mA	
T <sub>S</sub>	Storage temperature	-65	125	°C	

1. Absolute maximum continuous ratings are those maximum values beyond which damage to the device may occur. Exposure to these conditions or conditions beyond those indicated may adversely affect device reliability. Functional operation at absolute-maximum-rated conditions is not implied.

**Table 6. DC Characteristics (V<sub>CC</sub> = 3.3 V ± 5%, T<sub>A</sub> = -40° to 85°C)**

Symbol	Characteristics	Min	Typ	Max	Unit	Condition
V <sub>IH</sub>	Input High Voltage	2.0		V <sub>CC</sub> + 0.3	V	LVC MOS
V <sub>IL</sub>	Input Low Voltage			0.8	V	LVC MOS
V <sub>OH</sub>	Output High Voltage	2.4			V	I <sub>OH</sub> = -24 mA <sup>(1)</sup>
V <sub>OL</sub>	Output Low Voltage			0.55 0.30	V V	I <sub>OL</sub> = 24 mA I <sub>OL</sub> = 12 mA
Z <sub>OUT</sub>	Output Impedance		14 – 17		Ω	
I <sub>IN</sub>	Input Current <sup>(2)</sup>			±200	μA	V <sub>IN</sub> = V <sub>CC</sub> or GND
I <sub>CCA</sub>	Maximum PLL Supply Current		4.0	8.0	mA	V <sub>CCA</sub> Pin
I <sub>CCQ</sub>	Maximum Quiescent Supply Current		1.0	4.0	mA	All V <sub>CC</sub> Pins

1. The MPC9608 is capable of driving 50 Ω transmission lines on the incident edge. Each output drives one 50 Ω parallel terminated transmission line to a termination voltage of V<sub>TT</sub>. Alternatively, the device drives up to two 50 Ω series terminated transmission lines.
2. Inputs have pull-down resistors affecting the input current.

**Table 7. AC Characteristics** ( $V_{CC} = 3.3\text{ V} \pm 5\%$ ,  $T_A = -40^\circ$  to  $85^\circ\text{C}$ )<sup>(1)</sup>

Symbol	Characteristics	Min	Typ	Max	Unit	Condition
$f_{REF}$	Input reference frequency in PLL mode <sup>(2)</sup>	F_RANGE = 00	100	200	MHz	
		F_RANGE = 01	50	100	MHz	
		F_RANGE = 10	25	50	MHz	
		F_RANGE = 11	12.5	25	MHz	
		Input reference frequency in PLL bypass mode <sup>(3)</sup>	0	200	MHz	
$f_{max}$	Output Frequency <sup>(4)</sup>	F_RANGE = 00	100	200	MHz	BSEL = 0
		F_RANGE = 01	50	100	MHz	BSEL = 0
		F_RANGE = 10	25	50	MHz	BSEL = 0
		F_RANGE = 11	12.5	25	MHz	BSEL = 0
$t_{PW, MIN}$	Reference Input Pulse Width <sup>(5)</sup>	2.0			ns	
$t_r, t_f$	CCLK Input Rise/Fall Time			1.0	ns	0.8 V to 2.0 V
$t_{\phi}$	Propagation Delay (SPO) CCLK to FB_IN $f_{REF} = 100\text{ MHz}$ and above $f_{REF} = 12.5\text{ MHz}$ to $100\text{ MHz}$	-175 -1.75% of $t_{PER}$		+175 +1.75% of $t_{PER}$	ps ps	PLL Locked
$t_{SK(o)}$	Output-to-Output Skew  Within a bank Bank-to-bank All outputs, including QFB			80 100 150	ps	
DC	Output Duty Cycle	45	50	55	%	
$t_r, t_f$	Output Rise/Fall Time	0.1		1.0	ns	0.55 V to 2.4 V
$t_{PLZ, HZ}$	Output Disable Time			10	ns	
$t_{PZL, LZ}$	Output Enable Time			10	ns	
$t_{JIT(CC)}$	Cycle-to-cycle Jitter			150	ps	BSEL = 0
$t_{JIT(PER)}$	Period Jitter			150	ps	BSEL = 0
$t_{JIT(\phi)}$	I/O Phase Jitter RMS (1 $\sigma$ )			125	ps	BSEL = 0
BW	PLL closed loop bandwidth <sup>(6)</sup>	F_RANGE = 00		7 – 15	MHz	
		F_RANGE = 01		2 – 7	MHz	
		F_RANGE = 10		1 – 3	MHz	
		F_RANGE = 11		0.5 – 1.3	MHz	
$t_{LOCK}$	Maximum PLL Lock Time		10		ms	

- AC characteristics apply for parallel output termination of  $50\ \Omega$  to  $V_{TT}$ .
- PLL mode requires  $PLL\_EN = 0$  to enable the PLL and zero-delay operation.
- In bypass mode, the MPC9608 divides the input reference clock.
- Applies for bank A and for bank B if  $BSEL = 0$ . If  $BSEL = 1$ , the minimum and maximum output frequency of bank B is divided by two.
- Calculation of reference duty cycle limits:  $DC_{REF, MIN} = t_{PW, MIN} * f_{REF} * 100\%$  and  $DC_{REF, MAX} = 100\% - DC_{REF, MIN}$ . For example, at  $f_{REF} = 100\text{ MHz}$  the input duty cycle range is  $20\% < DC < 80\%$ .
- 3 dB point of PLL transfer characteristics.

APPLICATIONS INFORMATION

Power Supply Filtering

The MPC9608 is a mixed analog/digital product. Its analog circuitry is naturally susceptible to random noise, especially if this noise is seen on the power supply pins. Random noise on the V<sub>CCA</sub> (PLL) power supply impacts the device characteristics, for instance I/O jitter. The MPC9608 provides separate power supplies for the output buffers (V<sub>CC</sub>) and the phase-locked loop (V<sub>CCA</sub>) of the device. The purpose of this design technique is to isolate the high switching noise digital outputs from the relatively sensitive internal analog phase-locked loop. In a digital system environment where it is more difficult to minimize noise on the power supplies a second level of isolation may be required. The simple but effective form of isolation is a power supply filter on the V<sub>CCA</sub> pin for the MPC9608. Figure 3 illustrates a typical power supply filter scheme. The MPC9608 frequency and phase stability is most susceptible to noise with spectral content in the 100 kHz to 20 MHz range. Therefore the filter should be designed to target this range. The key parameter that needs to be met in the final filter design is the DC voltage drop across the series filter resistor R<sub>F</sub>. From the data sheet the I<sub>CCA</sub> current (the current sourced through the V<sub>CCA</sub> pin) is typically 4 mA (8 mA maximum), assuming that a minimum of 3.125 V must be maintained on the V<sub>CCA</sub> pin. The resistor R<sub>F</sub> shown in Figure 3 must have a resistance of 9 – 10 Ω (V<sub>CC</sub> = 3.3 V) to meet the voltage drop criteria.

R<sub>F</sub> = 9-10 Ω for V<sub>CC</sub> = 3.3 V      C<sub>F</sub> = 1 μF for V<sub>CC</sub> = 3.3 V

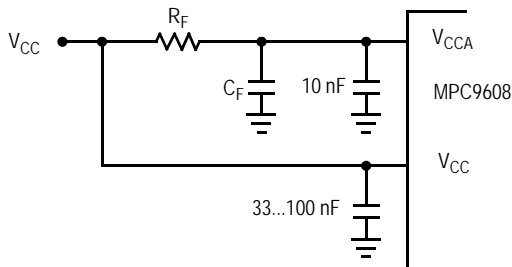


Figure 3. V<sub>CCA</sub> Power Supply Filter

The minimum values for R<sub>F</sub> and the filter capacitor C<sub>F</sub> are defined by the required filter characteristics: the RC filter should provide an attenuation greater than 40 dB for noise whose spectral content is above 100 kHz. In the example RC filter shown in Figure 3, the filter cut-off frequency is around 3-5 kHz and the noise attenuation at 100 kHz is better than 42 dB.

As the noise frequency crosses the series resonant point of an individual capacitor, its overall impedance begins to look inductive and thus increases with increasing frequency. The parallel capacitor combination shown ensures that a low impedance path to ground exists for frequencies well above the bandwidth of the PLL. Although the MPC9608 has several design features to minimize the susceptibility to power supply noise (isolated power and grounds and fully differential PLL), there still may be applications in which

overall performance is being degraded due to system power supply noise. The power supply filter schemes discussed in this section should be adequate to eliminate power supply noise related problems in most designs.

Using the MPC9608 in Zero-Delay Applications

Nested clock trees are typical applications for the MPC9608. Designs using the MPC9608, as LVCMOS PLL fanout buffer with zero insertion delay, will show significantly lower clock skew than clock distributions developed from CMOS fanout buffers. The external feedback option of the MPC9608 clock driver allows for its use as a zero delay buffer. By using the QFB output as a feedback to the PLL the propagation delay through the device is virtually eliminated. The PLL aligns the feedback clock output edge with the clock input reference edge resulting in a near zero delay through the device. The maximum insertion delay of the device in zero-delay applications is measured between the reference clock input and any output. This effective delay consists of the static phase offset, I/O jitter (phase or long-term jitter), feedback path delay and the output-to-output skew error relative to the feedback output.

Calculation of Part-to-Part Skew

The MPC9608 zero delay buffer supports applications where critical clock signal timing can be maintained across several devices. If the reference clock inputs of two or more MPC9608 are connected together, the maximum overall timing uncertainty from the common CCLK input to any output is:

$$t_{SK(PP)} = t_{(\emptyset)} + t_{SK(O)} + t_{PD, LINE(FB)} + t_{JIT(\emptyset)} \cdot CF$$

This maximum timing uncertainty consists of 4 components: static phase offset, output skew, feedback board trace delay, and I/O (phase) jitter:

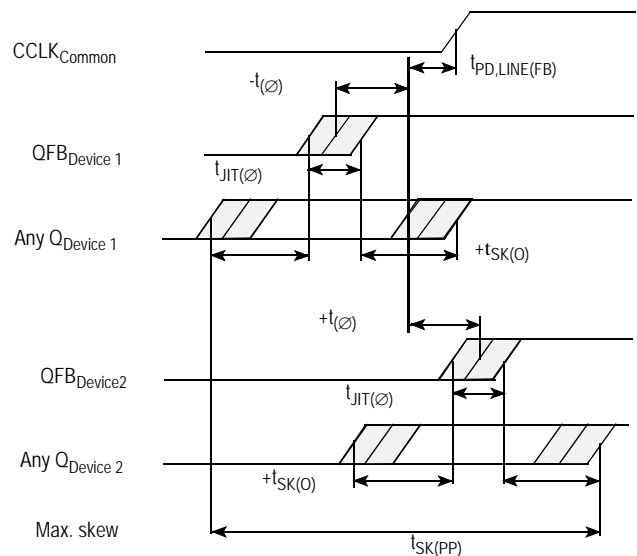


Figure 4. MPC9608 Maximum Device-to-Device Skew

Due to the statistical nature of I/O jitter, an RMS value ( $1\sigma$ ) is specified. I/O jitter numbers for other confidence factors (CF) can be derived from Table 8.

**Table 8. Confidence Factor CF**

CF	Probability of clock edge within the distribution
$\pm 1\sigma$	0.68268948
$\pm 2\sigma$	0.95449988
$\pm 3\sigma$	0.99730007
$\pm 4\sigma$	0.99993663
$\pm 5\sigma$	0.99999943
$\pm 6\sigma$	0.99999999

The feedback trace delay is determined by the board layout and can be used to fine-tune the effective delay through each device. In the following example calculation a I/O jitter confidence factor of 99.7% ( $\pm 3\sigma$ ) is assumed, resulting in a worst case timing uncertainty from input to any output of -295 ps to 295 ps<sup>(1)</sup> relative to CCLK:

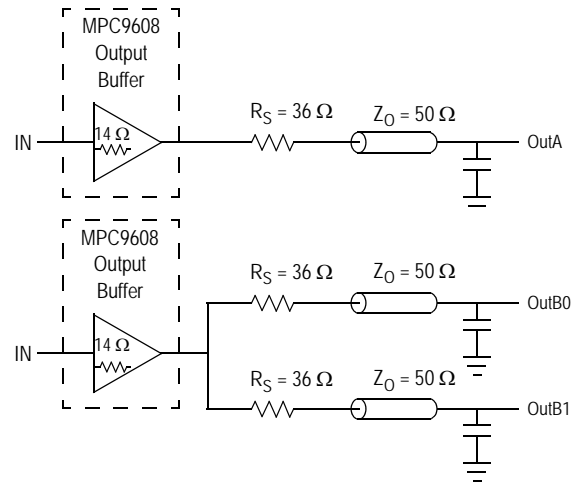
$$t_{SK(PP)} = [-100 \text{ ps} \dots 100 \text{ ps}] + [-150 \text{ ps} \dots 150 \text{ ps}] + [(15 \text{ ps} \cdot -3) \dots (15 \text{ ps} \cdot 3)] + t_{PD, LINE(FB)}$$

$$t_{SK(PP)} = [-295 \text{ ps} \dots 295 \text{ ps}] + t_{PD, LINE(FB)}$$

**Driving Transmission Lines**

The MPC9608 clock driver was designed to drive high speed signals in a terminated transmission line environment. To provide the optimum flexibility to the user the output drivers were designed to exhibit the lowest impedance possible. With an output impedance of less than 20  $\Omega$  the drivers can drive either parallel or series terminated transmission lines. For more information on transmission lines the reader is referred to Freescale Semiconductor application note AN1091. In most high performance clock networks point-to-point distribution of signals is the method of choice. In a point-to-point scheme either series terminated or parallel terminated transmission lines can be used. The parallel technique terminates the signal at the end of the line with a 50  $\Omega$  resistance to  $V_{CC} \div 2$ .

This technique draws a fairly high level of DC current and thus only a single terminated line can be driven by each output of the MPC9608 clock driver. For the series terminated case however there is no DC current draw, thus the outputs can drive multiple series terminated lines. Figure 5 illustrates an output driving a single series terminated line versus two series terminated lines in parallel. When taken to its extreme, the fanout of the MPC9608 clock driver is effectively doubled due to its capability to drive multiple lines.



**Figure 5. Single versus Dual Transmission Lines**

The waveform plots in Figure 6. Single versus Dual Waveforms show the simulation results of an output driving a single line versus two lines. In both cases the drive capability of the MPC9608 output buffer is more than sufficient to drive 50  $\Omega$  transmission lines on the incident edge. From the delay measurements in the simulations a delta of only 43 ps exists between the two differently loaded outputs. This suggests that the dual line driving need not be used exclusively to maintain the tight output-to-output skew of the MPC9608. The output waveform in Figure 6. Single versus Dual Waveforms shows a step in the waveform. This step is caused by the impedance mismatch seen looking into the driver. The parallel combination of the 36  $\Omega$  series resistor plus the output impedance does not match the parallel combination of the line impedances. The voltage wave launched down the two lines will equal:

$$V_L = V_S (Z_0 \div (R_S + R_0 + Z_0))$$

$$Z_0 = 50 \Omega \parallel 50 \Omega$$

$$R_S = 36 \Omega \parallel 36 \Omega$$

$$R_0 = 14 \Omega$$

$$V_L = 3.0 (25 \div (18 + 17 + 25))$$

$$= 1.31 \text{ V}$$

At the load end the voltage will double to 2.6 V due to the near unity reflection coefficient. It will then increment towards the quiescent 3.0 V in steps separated by one round trip delay (in this case 4.0 ns).

1. Skew data are designed targets and pending device specifications.

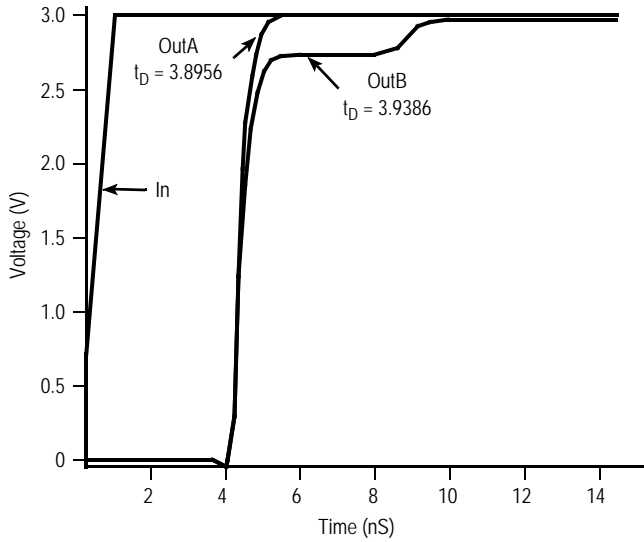


Figure 6. Single versus Dual Waveforms

Since this step is well above the threshold region, it will not cause any false clock triggering; however, designers may be uncomfortable with unwanted reflections on the line. To better match the impedances when driving multiple lines the situation in [Figure 7. Optimized Dual Line Termination](#) should be used. In this case the series terminating resistors are reduced such that when the parallel combination is added to the output buffer impedance the line impedance is perfectly matched.

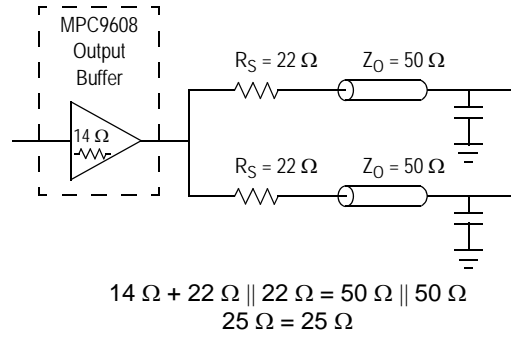


Figure 7. Optimized Dual Line Termination

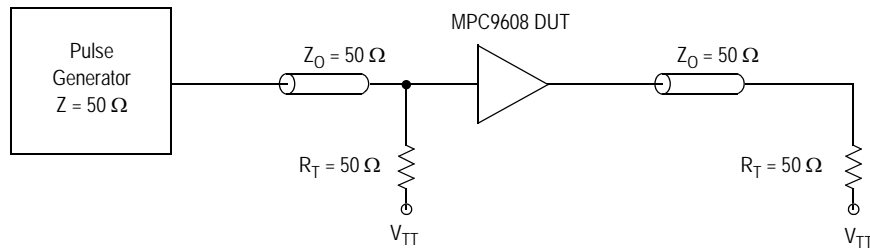
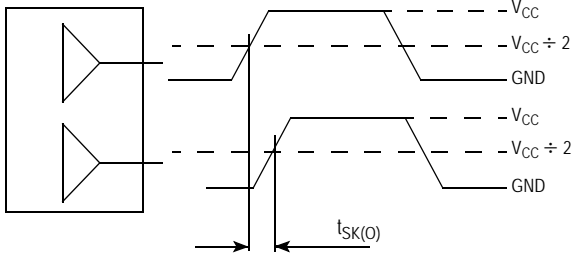


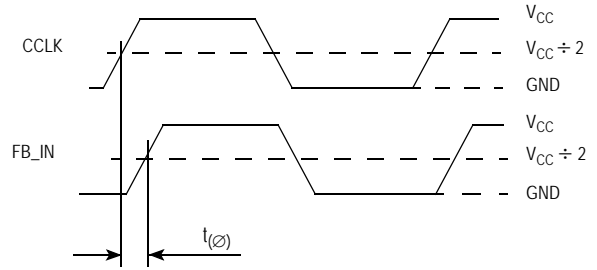
Figure 8. CCLK MPC9608 AC Test Reference for  $V_{CC} = 3.3\ V$



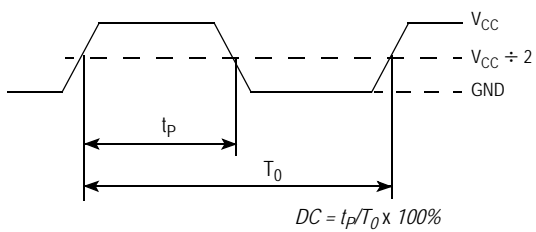


The pin-to-pin skew is defined as the worst case difference in propagation delay between any similar delay path within a single device.

**Figure 9. Output-to-Output Skew  $t_{SK(O)}$**

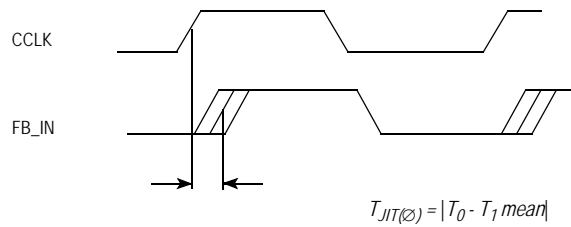


**Figure 10. Propagation Delay ( $t_{PD}$ , static phase offset) Test Reference**



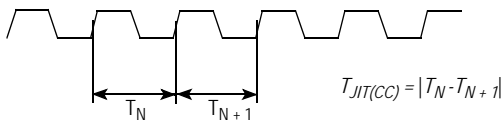
The time from the PLL controlled edge to the non controlled edge, divided by the time between PLL controlled edges, expressed as a percentage.

**Figure 11. Output Duty Cycle (DC)**



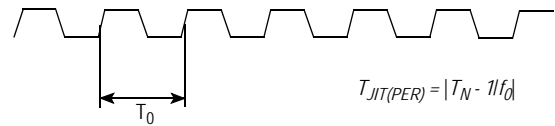
The deviation in  $t_0$  for a controlled edge with respect to a  $t_0$  mean in a random sample of cycles.

**Figure 12. I/O Jitter**



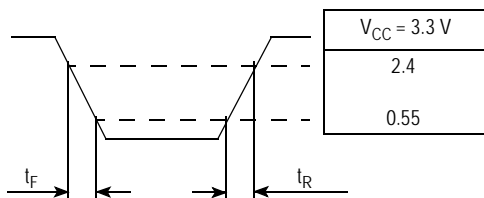
The variation in cycle time of a signal between adjacent cycles, over a random sample of adjacent cycle pairs.

**Figure 13. Cycle-to-Cycle Jitter**

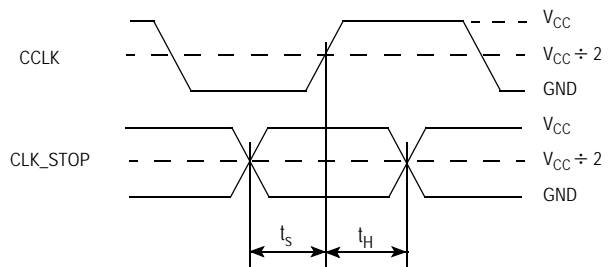


The deviation in cycle time of a signal with respect to the ideal period over a random sample of cycles.

**Figure 14. Period Jitter**

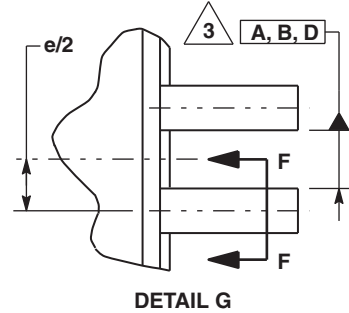
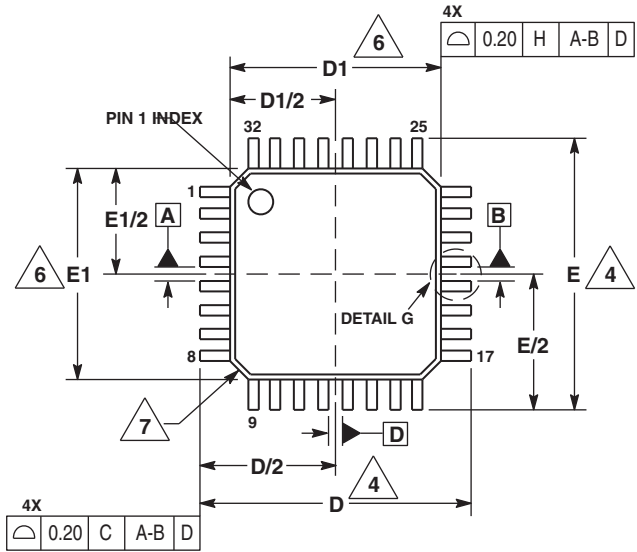


**Figure 15. Output Transition Time Test Reference**

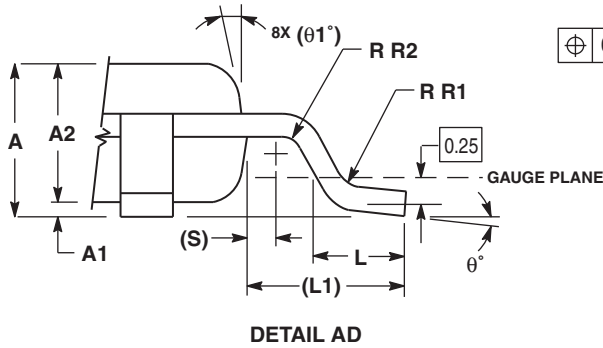
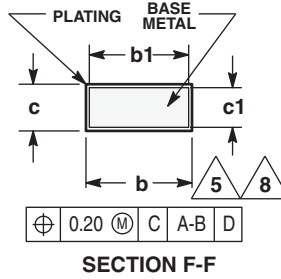
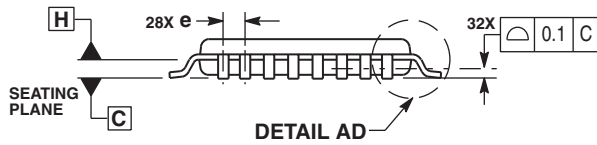


**Figure 16. Setup and Hold Time ( $t_s$ ,  $t_H$ ) Test Reference**

PACKAGE DIMENSIONS



- NOTES:
1. DIMENSIONS ARE IN MILLIMETERS.
  2. INTERPRET DIMENSIONS AND TOLERANCES PER ASME Y14.5M, 1994.
  3. DATUMS A, B, AND D TO BE DETERMINED AT DATUM PLANE H.
  4. DIMENSIONS D AND E TO BE DETERMINED AT SEATING PLANE C.
  5. DIMENSION b DOES NOT INCLUDE DAMBAR PROTRUSION. ALLOWABLE DAMBAR PROTRUSION SHALL NOT CAUSE THE LEAD WIDTH TO EXCEED THE MAXIMUM b DIMENSION BY MORE THAN 0.08-mm. DAMBAR CANNOT BE LOCATED ON THE LOWER RADIUS OR THE FOOT. MINIMUM SPACE BETWEEN PROTRUSION AND ADJACENT LEAD OR PROTRUSION: 0.07-mm.
  6. DIMENSIONS D1 AND E1 DO NOT INCLUDE MOLD PROTRUSION. ALLOWABLE PROTRUSION IS 0.25-mm PER SIDE. D1 AND E1 ARE MAXIMUM PLASTIC BODY SIZE DIMENSIONS INCLUDING MOLD MISMATCH.
  7. EXACT SHAPE OF EACH CORNER IS OPTIONAL.
  8. THESE DIMENSIONS APPLY TO THE FLAT SECTION OF THE LEAD BETWEEN 0.1-mm AND 0.25-mm FROM THE LEAD TIP.



DIM	MILLIMETERS	
	MIN	MAX
A	1.40	1.60
A1	0.05	0.15
A2	1.35	1.45
b	0.30	0.45
b1	0.30	0.40
c	0.09	0.20
c1	0.09	0.16
D	9.00 BSC	
D1	7.00 BSC	
e	0.80 BSC	
E	9.00 BSC	
E1	7.00 BSC	
L	0.50	0.70
L1	1.00 REF	
q	0°	7°
q1	12 REF	
R1	0.08	0.20
R2	0.08	---
S	0.20 REF	

CASE 873A-03  
ISSUE B  
32-LEAD LQFP PACKAGE

## NOTES

## Revision History Sheet

Rev	Table	Page	Description of Change	Date
4		1	NRND – Not Recommend for New Designs	1/7/13
4		1	Product Discontinuation Notice - Last time buy expires September 7, 2016. PDN N-16-02	3/15/16



## IMPORTANT NOTICE AND DISCLAIMER

RENESAS ELECTRONICS CORPORATION AND ITS SUBSIDIARIES (“RENESAS”) PROVIDES TECHNICAL SPECIFICATIONS AND RELIABILITY DATA (INCLUDING DATASHEETS), DESIGN RESOURCES (INCLUDING REFERENCE DESIGNS), APPLICATION OR OTHER DESIGN ADVICE, WEB TOOLS, SAFETY INFORMATION, AND OTHER RESOURCES “AS IS” AND WITH ALL FAULTS, AND DISCLAIMS ALL WARRANTIES, EXPRESS OR IMPLIED, INCLUDING, WITHOUT LIMITATION, ANY IMPLIED WARRANTIES OF MERCHANTABILITY, FITNESS FOR A PARTICULAR PURPOSE, OR NON-INFRINGEMENT OF THIRD-PARTY INTELLECTUAL PROPERTY RIGHTS.

These resources are intended for developers who are designing with Renesas products. You are solely responsible for (1) selecting the appropriate products for your application, (2) designing, validating, and testing your application, and (3) ensuring your application meets applicable standards, and any other safety, security, or other requirements. These resources are subject to change without notice. Renesas grants you permission to use these resources only to develop an application that uses Renesas products. Other reproduction or use of these resources is strictly prohibited. No license is granted to any other Renesas intellectual property or to any third-party intellectual property. Renesas disclaims responsibility for, and you will fully indemnify Renesas and its representatives against, any claims, damages, costs, losses, or liabilities arising from your use of these resources. Renesas' products are provided only subject to Renesas' Terms and Conditions of Sale or other applicable terms agreed to in writing. No use of any Renesas resources expands or otherwise alters any applicable warranties or warranty disclaimers for these products.

(Disclaimer Rev.1.01 Jan 2024)

### Corporate Headquarters

TOYOSU FORESIA, 3-2-24 Toyosu,  
Koto-ku, Tokyo 135-0061, Japan  
[www.renesas.com](http://www.renesas.com)

### Trademarks

Renesas and the Renesas logo are trademarks of Renesas Electronics Corporation. All trademarks and registered trademarks are the property of their respective owners.

### Contact Information

For further information on a product, technology, the most up-to-date version of a document, or your nearest sales office, please visit [www.renesas.com/contact-us/](http://www.renesas.com/contact-us/).