

The MPC9824 is a PLL based clock generator specifically designed for Freescale Microprocessor and Microcontroller applications including the PowerPC and PowerQUICC. This device generates the microprocessor input clock and other microprocessor system and bus clocks at any one of eight output frequencies. These frequencies include 33, 50, 66, 100, 125, 133.33, 166.66 and 200 MHz. The device offers six low skew clock outputs plus the three reference outputs. The clock input reference is 25 MHz and may be derived from an external source or by the addition of a 25 MHz crystal to the on-chip crystal oscillator. The extended temperature range of the MPC9824 supports telecommunication and networking requirements.

Features

- 6 LVCMOS outputs for processor and other system circuitry
- 3 Buffered 25 MHz reference clock outputs
- Crystal oscillator or external reference input
- 25 MHz Input reference frequency
- Selectable output frequencies = 33.33, 50, 66.66, 100, 125, 133.33, 166.66, or 200 MHz
- Low cycle-to-cycle and period jitter
- Package = 32 lead LQFP
- 3.3 V supply
- Supports computing, networking, telecommunications applications
- Ambient temperature range -40°C to +85°C
- **For functional replacement use 8T49N285A**

MPC9824

**MICROPROCESSOR
CLOCK GENERATOR**



~~**FA SUFFIX
32-LEAD LQFP PACKAGE
CASE 873A-04**~~



**AC SUFFIX
32-LEAD LQFP PACKAGE
Pb-FREE PACKAGE
CASE 873A-04**

Functional Description

The MPC9824 uses a PLL with a 25 MHz input reference frequency to generate a single bank of 6 configurable LVCMOS output clocks. The output frequency of this bank is configurable by three FSEL pins. The 25 MHz reference may be either an external frequency source or a 25 MHz crystal. The 25 MHz crystal is directly connected to the XTAL_IN and XTAL_OUT pins with no additional components required. An external reference may be applied to the XTAL_IN pin with the XTAL_OUT pin left floating. The input reference, whether provided by a crystal or an external input is also directly buffered to a second bank of 3 LVCMOS outputs. These outputs may be used as the clock source for processor I/O applications such as an Ethernet PHY.

The MPC9824 is packaged in a 32 lead LQFP package.

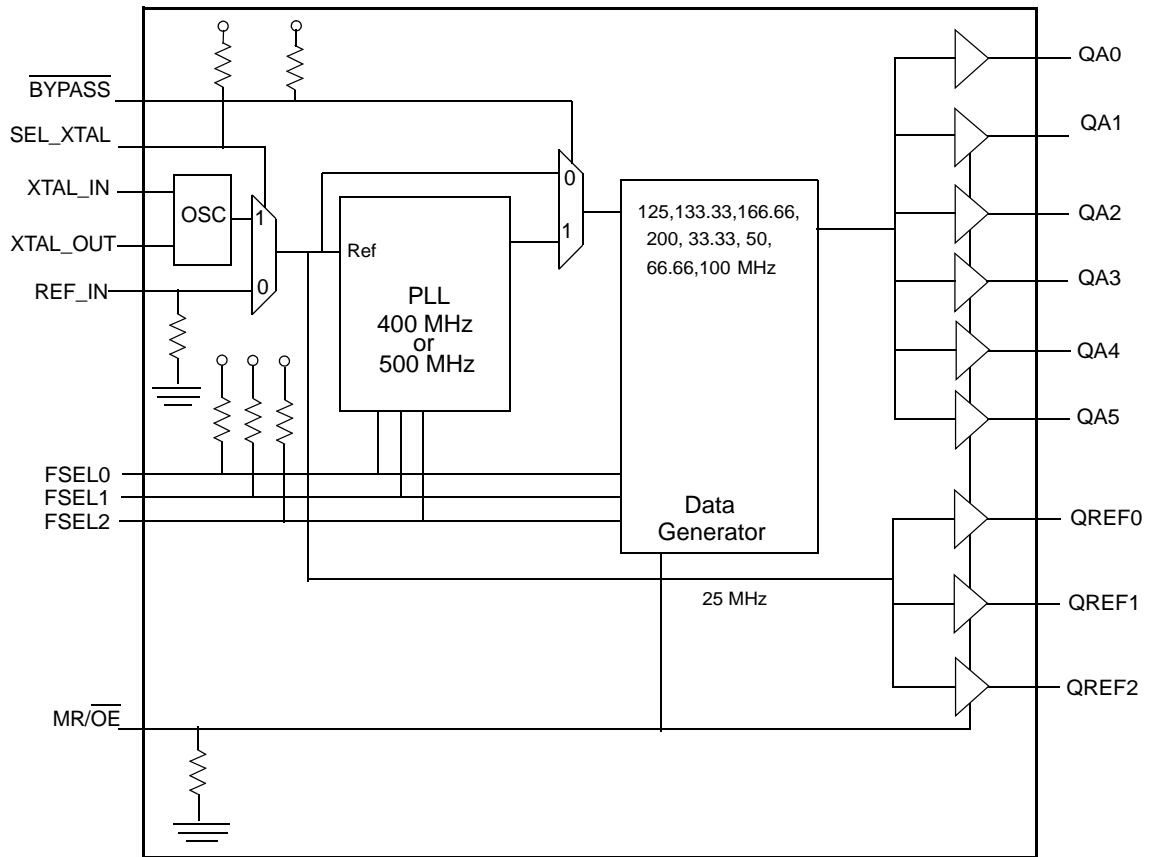

Figure 1. MPC9824 Logic Diagram

Table 1. Pin configuration

Pin	I/O	Type	Function
QA0, QA1, QA2 QA3, QA4, QA5	Output	LVC MOS	Clock Outputs
QREF0, QREF1, QREF2	Output	LVC MOS	Reference Output (25 MHz)
XTAL_IN	Input	LVC MOS	Crystal Oscillator Input Pin
XTAL_OUT	Output	LVC MOS	Crystal Oscillator Output Pin
REF_IN	Input	LVC MOS	External Reference Input (internal pull-down)
SEL_XTAL	Input	LVC MOS	Selects between XTAL or External Source (internal pull-up)
FSEL0 FSEL1 FSEL2	Input	LVC MOS	Configures Bank A Clock Output Frequency (internal pull-up)
$\overline{\text{BYPASS}}$	Input	LVC MOS	Test Mode to Bypass PLL (active low, internal pull-up)
$\overline{\text{MR/OE}}$	Input	LVC MOS	Master Reset (internal pull-down)
V_{DDA}			Analog Supply, An external filter is recommended
V_{DD}	—	—	3.3 V Supply
GND	—	—	Ground

Table 2. FSEL Function Table

FSEL0	FSEL1	FSEL2	VCO Frequency	Output Frequency
0	0	0	400	33.33 MHz
0	0	1	400	66.66 MHz
0	1	0	400	50 MHz
0	1	1	400	100 MHz
1	0	0	500	125 MHz
1	0	1	500	166.66 MHz
1	1	0	400	133.33 MHz
1	1	1	400	200 MHz

Table 3. Function Table

Control	0	1
SEL_XTAL	External Reference	Crystal Input
$\overline{\text{BYPASS}}$	PLL Bypassed	Normal Operation
$\overline{\text{MR/OE}}$	Normal	Reset

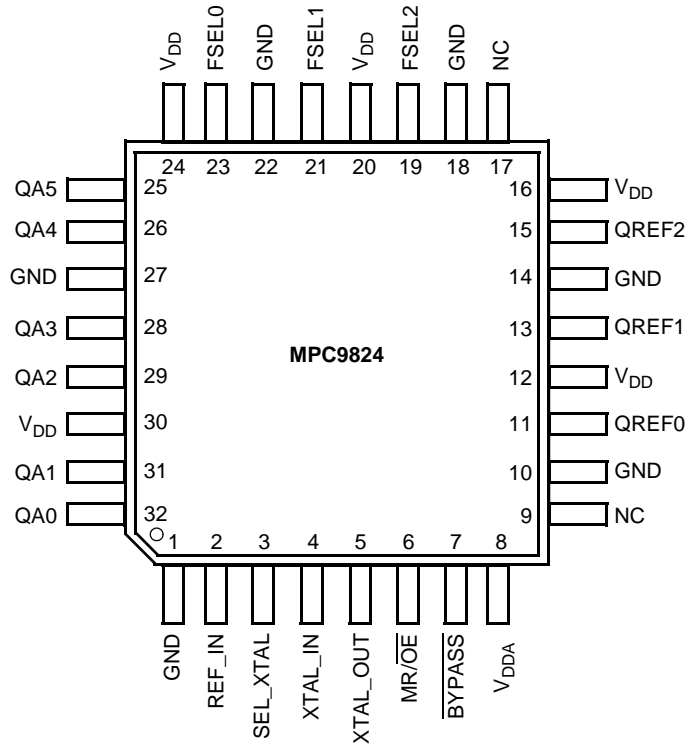

Figure 2. MPC9824 32-Lead LQFP Package Pinout (Top View)

MPC9824 OPERATION

Crystal Oscillator

The MPC9824 features a fully integrated Pierce oscillator to minimize system implementation costs. The MPC9824 may be operated with a 25 MHz crystal without other components. For operation without external components, the crystal selection should be of a 25 MHz parallel resonant type with a load specification of $CL = 10\text{ pF}$. See Table 4 for complete crystal specifications.

If more precise frequency control is desired, the addition of capacitors from each of the XTAL_IN and XTAL_OUT pins to ground may be used to trim the frequency as shown in Figure 3. In this case the recommended crystal should have a $CL = 18\text{ pF}$.

In either case the crystal should be located as close to the MPC9824 XTAL_IN and XTAL_OUT pins as possible to minimize any board level parasitic capacitance.

Table 4. Crystal Specifications

Parameter	Value	Value (with trim caps)
Crystal Cut	Fundamental AT Cut	Fundamental AT Cut
Resonance	Parallel Resonance	Parallel Resonance
Shunt Capacitance (C_0)	5–7 pF	5–7 pF
Load Capacitance (C_L)	18 pF	18 pF
Equivalent Series Resistance (ESR)	20–50 Ω	20–50 Ω

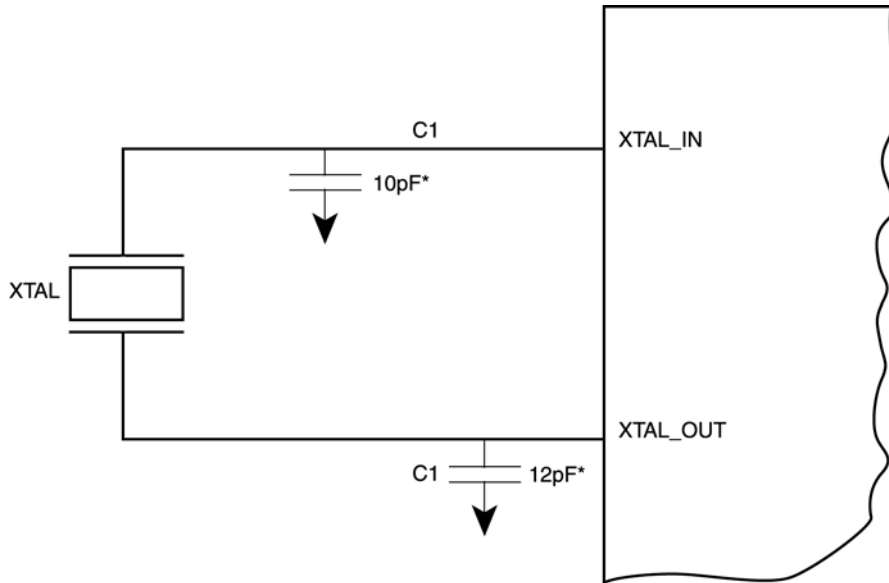

Figure 3 Crystal with Trim Caps

*NOTE: These are recommended values and are subject to change due to specific crystal parameter and board layout. Refer to ICS Application Notes for further information on the crystal selection.

Power-Supply Bypassing

The MPC9824 should have all V_{DD} pins bypassed with $0.01\text{ }\mu\text{F}$ capacitors and a minimum of one $1.0\text{ }\mu\text{F}$ capacitor for the overall package. All capacitors should be located as close to the package as possible.

An external RC filter from V_{DD} to V_{DDA} is recommended as shown in Figure 4.

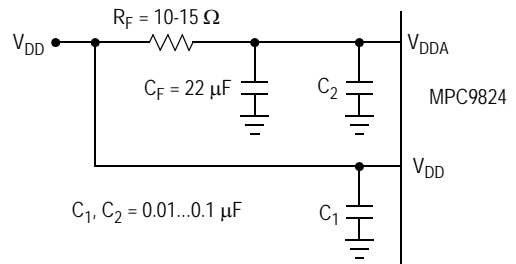

Figure 4. Power Supply Filter

Table 5. Absolute Maximum Ratings⁽¹⁾

Symbol	Characteristics	Min	Max	Unit	Condition
V _{DD}	Supply Voltage	-0.3	3.8	V	
I _{IN}	DC Input Current		±20	mA	
I _{OUT}	DC Output Current		±75	mA	
T _S	Storage Temperature	-65	125	°C	

1. Absolute maximum continuous ratings are those maximum values beyond which damage to the device may occur. Exposure to these conditions or conditions beyond those indicated may adversely affect device reliability. Functional operation at absolute-maximum-rated conditions is not implied.

Table 6. General Specifications

Symbol	Characteristics	Min	Typ	Max	Unit	Condition
V _{TT}	Output Termination Voltage		V _{DD} ÷ 2		V	
MM	ESD Protection (Machine model)	200			V	
HBM	ESD Protection (Human body model)	2000			V	
LU	Latch-Up Immunity	200			mA	
C _{IN}	Input Capacitance		4		pF	Inputs
T _C	Ambient Temperature	-40		85	°C	
C _{PD}	Power Dissipation Capacitance		10		pF	Per output
R _{PU} , R _{PD}	Pull-up/Pull-down Resistance			75	KΩ	

Table 7. DC Characteristics (V_{DD} = 3.3 V ± 5%, T_A = -40°C to +85°C)

Symbol	Characteristics	Min	Typ	Max	Unit	Condition
V _{IH}	Input High Voltage (xtal_in)	2.4		V _{DD} + 0.3	V	Input threshold = V _{DD} /2
V _{IH}	Input High Voltage	2.0		V _{DD} + 0.3	V	
V _{IL}	Input Low Voltage			0.8	V	LVCMOS
I _{IN}	Input Current ⁽¹⁾			±150	μA	V _{IN} = V _{DD} or GND
V _{OH}	Output High Voltage	2.4			V	I _{OH} = -12 mA
V _{OL}	Output Low Voltage			0.4	V	I _{OL} = 12 mA
Z _{OUT}	Output Impedance		14		Ω	
I _{DD}	Maximum Quiescent Supply Current			3.5	mA	V _{DD} pins, output not loaded
I _{DDA}	Maximum Quiescent Supply Current			6.5	mA	V _{DDA} pins, output not loaded

1. Inputs have pull-down or pull-down resistors affecting the input current.

Table 8. AC Characteristics ($V_{DD} = 3.3\text{ V} \pm 5\%$, $T_A = -40^\circ\text{C}$ to $+85^\circ\text{C}$) ⁽¹⁾

Symbol	Characteristics	Min	Typ	Max	Unit	Condition
Input and Output Timing Specification						
f_{ref}	Input Reference Frequency (25 MHz input) XTAL Input		25 25		MHz MHz	
f_{VCO}	VCO Frequency Range FSEL0, FSEL1, FSEL2 = 000,001, 010,011,110,111 FSEL0, FSEL1, FSEL2 = 100,101		400 500		MHz	
f_{MCX}	Output Frequency (QAx) FSEL0, FSEL1, FSEL2 = 000 FSEL0, FSEL1, FSEL2 = 001 FSEL0, FSEL1, FSEL2 = 010 FSEL0, FSEL1, FSEL2 = 011 FSEL0, FSEL1, FSEL2 = 100 FSEL0, FSEL1, FSEL2 = 101 FSEL0, FSEL1, FSEL2 = 110 FSEL0, FSEL1, FSEL2 = 111 Output Frequency (QREFx)		33.33 66.66 50 100 125 166.66 133.33 200 25		MHz	PLL locked
DC	Output Duty Cycle	45	50	55	%	
f_{out}	Output Frequency Accuracy Crystal ⁽²⁾ External Reference	0		100 0	ppm ppm	
PLL Specifications						
BW	PLL Closed Loop Bandwidth ⁽³⁾		500		kHz	
t_{LOCK}	Maximum PLL Lock Time			10	ms	
Skew and Jitter Specifications						
$t_{sk(O)}$	Output-to-Output Skew			100	ps	within bank
$t_{JIT(CC)}$	Cycle-to-Cycle Jitter			100	ps	QA output
$t_{JIT(PER)}$	Period Jitter			75	ps	QA output
$t_{JIT(\emptyset)}$	I/O Phase Jitter, RMS			30	ps	
t_r, t_f	Output Rise/Fall Time			750	ps	20% to 80%
t_{JIT}	Phase Noise Jitter, RMS; 25MHz, Integration Range: 1.875MHz - 20MHz			2.5	ps	QREF pin

1. AC characteristics apply for parallel output termination of 50Ω to V_{TT} .
2. Based upon recommended crystal specifications and tune-in capacitors as outlined in operation section..
3. dB point of PLL transfer characteristics.

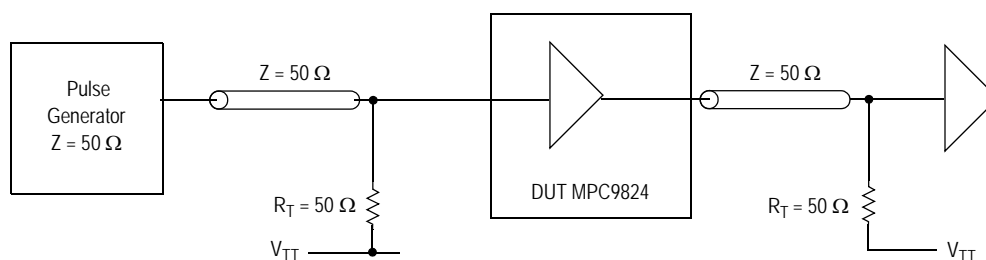

Figure 5. MPC9824 AC Test Reference (LVC MOS Outputs)

RELIABILITY INFORMATION

Table 9. θ_{JA} vs. Air Flow Table for 32 Lead LQFP

θ_{JA} BY VELOCITY (LINEAR FEET PER MINUTE)			
	67.8°C/W	55.9°C/W	50.1°C/W
	47.9°C/W	42.1°C/W	39.4°C/W
	0	200	500
Single-Layer PCB, JEDEC Standard Test Boards			
Multi-Layer PCB, JEDEC Standard Test Boards			
NOTE: Most modern PCB designs use multi-layered boards. The data in the second row pertains to most designs.			

PACKAGE DIMENSIONS

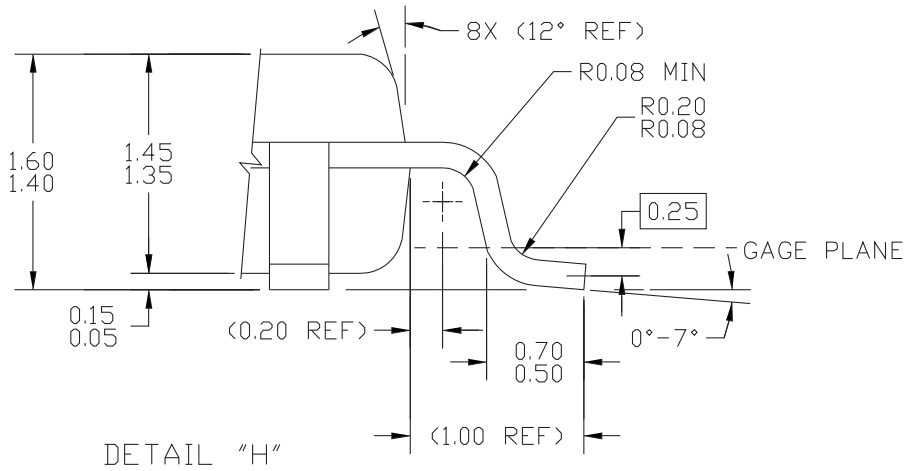
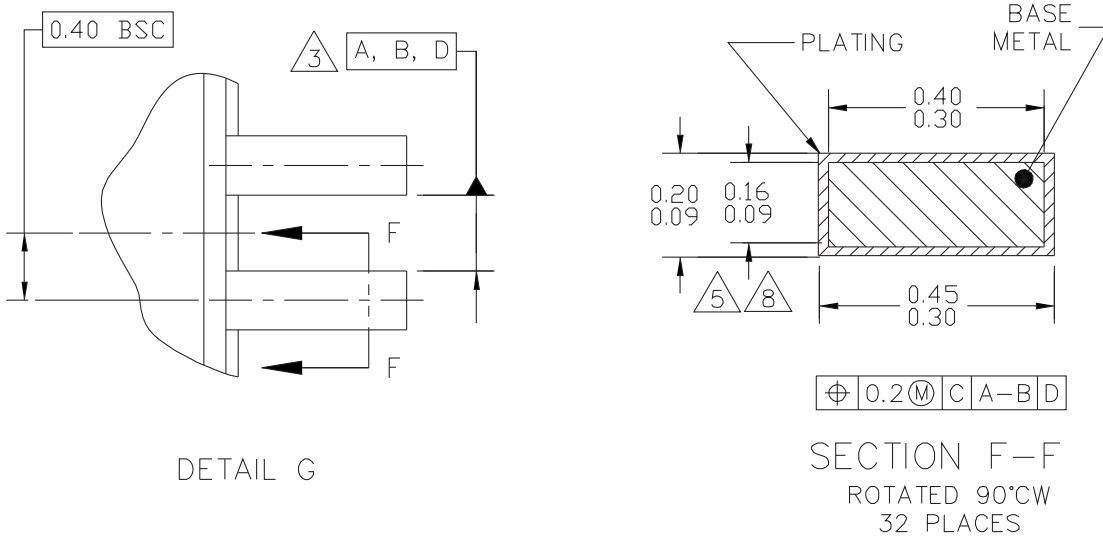

© FREESCALE SEMICONDUCTOR, INC. ALL RIGHTS RESERVED.	MECHANICAL OUTLINE	PRINT VERSION NOT TO SCALE	
TITLE: LOW PROFILE QUAD FLAT PACK (LQFP) 32 LEAD, 0.8 PITCH (7 X 7 X 1.4)	DOCUMENT NO: 98ASH70029A	REV: C	
	CASE NUMBER: 873A-04	01 APR 2005	
	STANDARD: JEDEC MS-026 BBA		

**CASE 873A-04
ISSUE C
32-LEAD LQFP PACKAGE**

PACKAGE DIMENSIONS

NOTES:

1. DIMENSIONS ARE IN MILLIMETERS.
2. INTERPRET DIMENSIONS AND TOLERANCES PER ASME Y14.5-1994.
3. DATUMS A, B, AND D TO BE DETERMINED AT DATUM PLANE H.
4. DIMENSIONS TO BE DETERMINED AT SEATING PLANE DATUM C.
5. DIMENSION DOES NOT INCLUDE DAMBAR PROTRUSION. ALLOWABLE DAMBAR PROTRUSION SHALL NOT CAUSE THE LEAD WIDTH TO EXCEED THE MAXIMUM DIMENSION BY MORE THAN 0.08 MM. DAMBAR CANNOT BE LOCATED ON THE LOWER RADIUS OR THE FOOT. MINIMUM SPACE BETWEEN PROTRUSION AND ADJACENT LEAD OR PROTRUSION: 0.07 MM.
6. DIMENSIONS DO NOT INCLUDE MOLD PROTRUSION. ALLOWABLE PROTRUSION IS 0.25 MM PER SIDE. DIMENSIONS ARE MAXIMUM PLASTIC BODY SIZE DIMENSIONS INCLUDING MOLD MISMATCH.
7. EXACT SHAPE OF EACH CORNER IS OPTIONAL.
8. THESE DIMENSIONS APPLY TO THE FLAT SECTION OF THE LEAD BETWEEN 0.1 MM AND 0.25 MM FROM THE LEAD TIP.

© FREESCALE SEMICONDUCTOR, INC. ALL RIGHTS RESERVED.	MECHANICAL OUTLINE	PRINT VERSION NOT TO SCALE	
TITLE: LOW PROFILE QUAD FLAT PACK (LQFP) 32 LEAD, 0.8 PITCH (7 X 7 X 1.4)	DOCUMENT NO: 98ASH70029A	REV: C	
	CASE NUMBER: 873A-04	01 APR 2005	
	STANDARD: JEDEC MS-026 BBA		

**CASE 873A-04
ISSUE C
32-LEAD LQFP PACKAGE**

PACKAGE DIMENSIONS

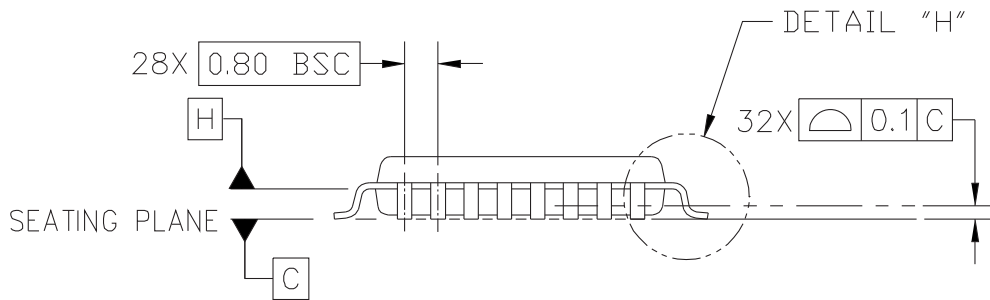
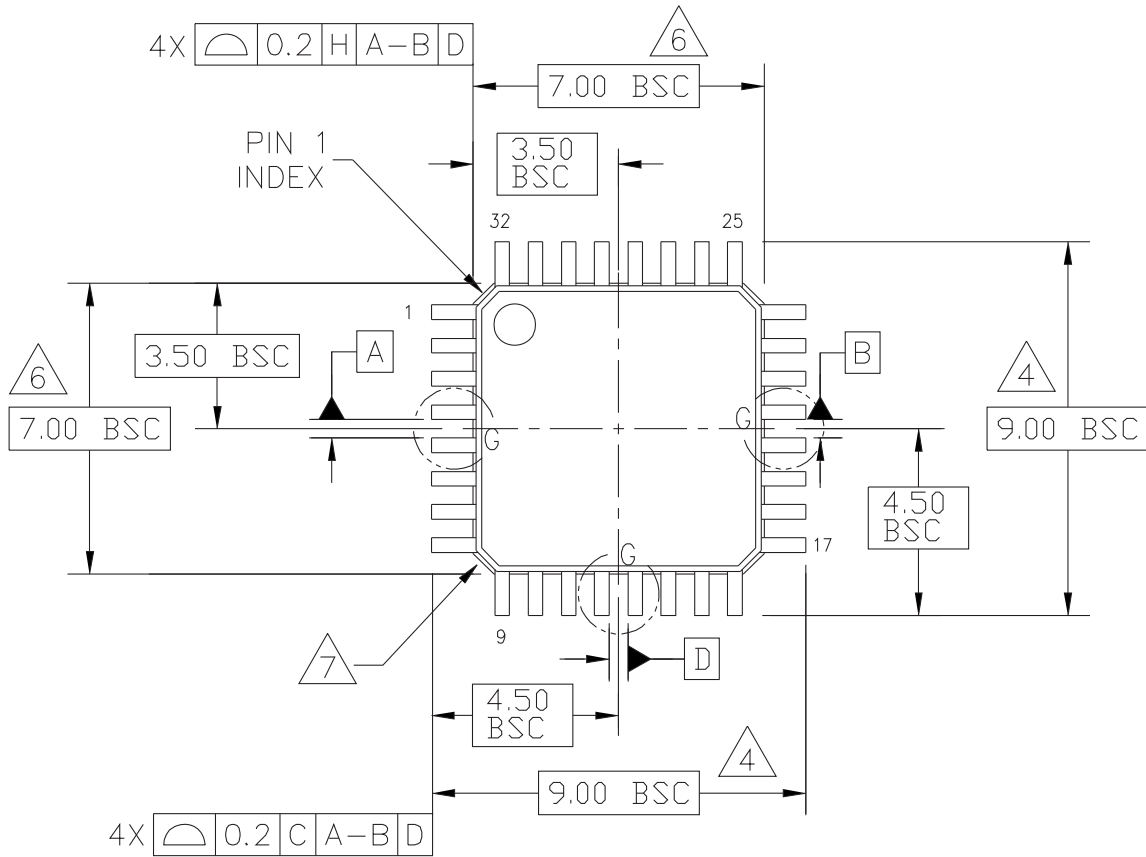

© FREESCALE SEMICONDUCTOR, INC. ALL RIGHTS RESERVED.	MECHANICAL OUTLINE	PRINT VERSION NOT TO SCALE	
TITLE: LOW PROFILE QUAD FLAT PACK (LQFP) 32 LEAD, 0.8 PITCH (7 X 7 X 1.4)	DOCUMENT NO: 98ASH70029A	REV: C	
	CASE NUMBER: 873A-04	01 APR 2005	
	STANDARD: JEDEC MS-026 BBA		

**CASE 873A-04
ISSUE C
32-LEAD LQFP PACKAGE**

Revision History Sheet

Rev	Table	Page	Description of Change	Date
2		1	NRND – Not Recommend for New Designs	2/15/2013
2		1	Removed NRND.	5/5/15
2		1	Product Discontinuation Notice - Last time buy expires September 7, 2016. PDN N-16-02	3/16/16

IMPORTANT NOTICE AND DISCLAIMER

RENESAS ELECTRONICS CORPORATION AND ITS SUBSIDIARIES (“RENESAS”) PROVIDES TECHNICAL SPECIFICATIONS AND RELIABILITY DATA (INCLUDING DATASHEETS), DESIGN RESOURCES (INCLUDING REFERENCE DESIGNS), APPLICATION OR OTHER DESIGN ADVICE, WEB TOOLS, SAFETY INFORMATION, AND OTHER RESOURCES “AS IS” AND WITH ALL FAULTS, AND DISCLAIMS ALL WARRANTIES, EXPRESS OR IMPLIED, INCLUDING, WITHOUT LIMITATION, ANY IMPLIED WARRANTIES OF MERCHANTABILITY, FITNESS FOR A PARTICULAR PURPOSE, OR NON-INFRINGEMENT OF THIRD-PARTY INTELLECTUAL PROPERTY RIGHTS.

These resources are intended for developers who are designing with Renesas products. You are solely responsible for (1) selecting the appropriate products for your application, (2) designing, validating, and testing your application, and (3) ensuring your application meets applicable standards, and any other safety, security, or other requirements. These resources are subject to change without notice. Renesas grants you permission to use these resources only to develop an application that uses Renesas products. Other reproduction or use of these resources is strictly prohibited. No license is granted to any other Renesas intellectual property or to any third-party intellectual property. Renesas disclaims responsibility for, and you will fully indemnify Renesas and its representatives against, any claims, damages, costs, losses, or liabilities arising from your use of these resources. Renesas' products are provided only subject to Renesas' Terms and Conditions of Sale or other applicable terms agreed to in writing. No use of any Renesas resources expands or otherwise alters any applicable warranties or warranty disclaimers for these products.

(Disclaimer Rev.1.01 Jan 2024)

Corporate Headquarters

TOYOSU FORESIA, 3-2-24 Toyosu,
Koto-ku, Tokyo 135-0061, Japan
www.renesas.com

Trademarks

Renesas and the Renesas logo are trademarks of Renesas Electronics Corporation. All trademarks and registered trademarks are the property of their respective owners.

Contact Information

For further information on a product, technology, the most up-to-date version of a document, or your nearest sales office, please visit www.renesas.com/contact-us/.