

QLx111GRx

11.1Gb/s Lane Extender

FN6987
Rev 0.00
October 26, 2009

The QLx111GRx is a settable single-channel receive-side equalizer with extended functionality for advanced protocols operating with line rates up to 11.1Gb/s such as 10G Ethernet (10GBase-CR). The QLx111GRx compensates for the frequency dependent attenuation of copper twin-axial cables, extending the signal reach up to at least 10m on 28AWG cable.

The small form factor, highly-integrated design is ideal for high-density data transmission applications including active copper cable assemblies. The equalizing filter within the QLx111GRx can be set to provide optimal signal fidelity for a given media and length. The compensation level for the filter is set by two external control pins.

Operating on a single 1.2V power supply, the QLx111GRx enables per channel throughputs of 10Gb/s to 11.1Gb/s while supporting lower data rates including 8.5, 6.25, 5, 4.25, 3.125, and 2.5Gb/s. The QLx111GRx uses current mode logic (CML) input/output and is packaged in a 3mmx3mm 16 lead QFN. LOS support is included for module applications.

Features

- Supports data rates up to 11.1Gb/s
- Low power (<135mW)
- Low latency (<500ps)
- Single channel equalizer in a 3mmx3mm QFN package for straight route-through architecture and simplified routing
- Adjustable equalizer boost
- Supports 64b/66b encoded data – long run lengths
- Line silence preservation
- 1.2V supply voltage
- LOS support

Applications

- SFP+ active copper cable modules
- QSFP active copper cable modules
- 10G Ethernet (10GBase-CR)
- XFI
- 40G Ethernet (40GBase-CR4)
- Fibre Channel
- High-speed active cable assemblies
- High-speed printed circuit board (PCB) traces

Benefits

- Thinner gauge cable
- Extends cable reach greater than 3x
- Improved BER

Typical Application Circuit

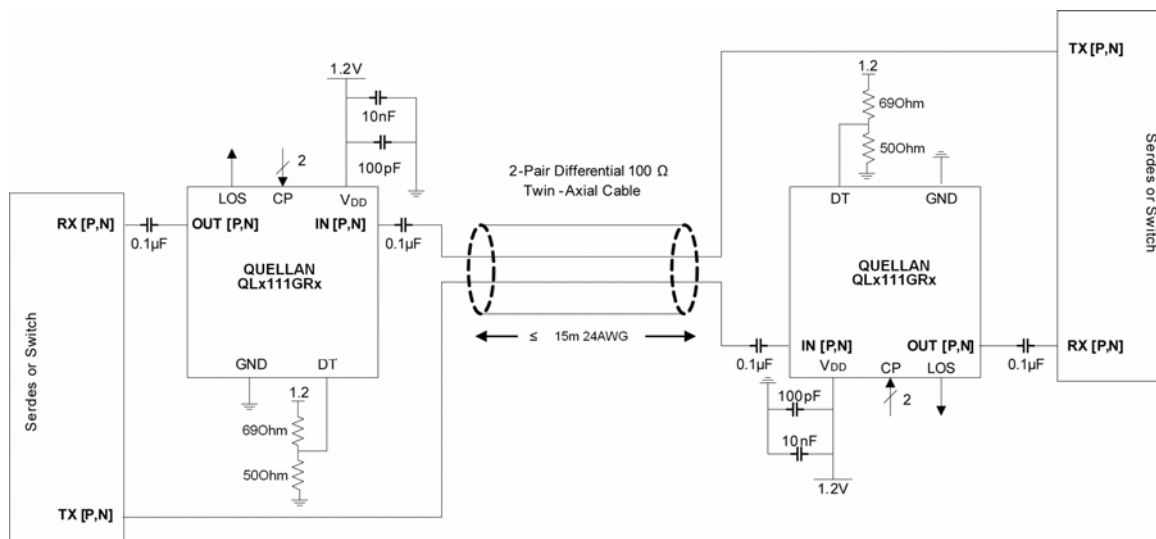

Ordering Information

PART NUMBER (Note)	PART MARKING	TEMP. RANGE (°C)	PACKAGE (Pb-Free)	PKG. DWG. #
QLX111RIQT7	QL111	0 to +70	16 Ld QFN 7" Prod. Tape & Reel; Qty 1,000	L16.3x3B
QLX111RIOQR	QL111	0 to +70	16 Ld QFN 7" Sample Reel; Qty 100	L16.3x3B

NOTE: These Intersil Pb-free plastic packaged products employ special Pb-free material sets, molding compounds/die attach materials, and 100% matte tin plate plus anneal (e3 termination finish, which is RoHS compliant and compatible with both SnPb and Pb-free soldering operations). Intersil Pb-free products are MSL classified at Pb-free peak reflow temperatures that meet or exceed the Pb-free requirements of IPC/JEDEC J STD-020.

Pin Configuration

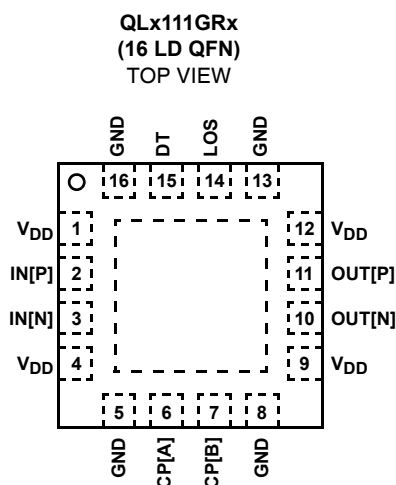

Pin Descriptions

PIN NAME	PIN NUMBER	DESCRIPTION
V _{DD}	1, 4, 12, 9	Power supply. 1.2V supply voltage. The use of parallel 100pF and 10nF decoupling capacitors to ground is recommended for each of these pins for broad high-frequency noise suppression.
IN[P,N]	2, 3	Equalizer 1 differential input, CML. The use of 100nF low ESL/ESR MLCC capacitor with at least 6GHz frequency response is recommended.
CP[A,B]	6, 7	Control pins for setting the equalizer. CMOS logic inputs. Pins are read as a 2-digit number to set the boost level. Pins are internally pulled up and down through a 23kΩ resistor.
OUT[P,N]	11, 10	Equalizer differential output, CML. The use of 100nF low ESL/ESR MLCC capacitor with at least 6GHz frequency response is recommended.
LOS	14	LOS indicator. High output when equalized In signal is below DT threshold. Open drain output internally pulled up to V _{DD} with a 10kΩ resistor.
DT	15	Detection Threshold. Reference DC voltage threshold for input signal power detection. Data output OUT is muted when the power of the equalized version of IN falls below the threshold. Tie to ground to disable electrical idle preservation and always enable the limiting amplifier.
GND	5, 8, 13, 16	Ground

Absolute Maximum Ratings

Supply Voltage (V_{DD} to GND)	-0.3V to 1.3V
Voltage at All Input Pins	-0.3V to $V_{DD} + 0.3V$
ESD Rating	
High Speed Pins	1.5kV (HBM)
All Other Pins	2kV (HBM)

Thermal Information

Operating Ambient Temperature Range	0°C to +85°C
Storage Ambient Temperature Range	-55°C to +150°C
Maximum Junction Temperature	+125°C
Pb-Free Reflow Profile	see link below http://www.intersil.com/pbfree/Pb-FreeReflow.asp

CAUTION: Do not operate at or near the maximum ratings listed for extended periods of time. Exposure to such conditions may adversely impact product reliability and result in failures not covered by warranty.

Operating Conditions

PARAMETER	SYMBOL	CONDITION	MIN	TYP	MAX	UNITS
Supply Voltage	V_{DD}		1.1	1.2	1.3	V
Operating Ambient Temperature	T_A		0	25	70	°C
Bit Rate		NRZ data applied to any channel	2.5		11.1	Gb/s

Control Pin Characteristics Typical values are at $V_{DD} = 1.2V$, $T_A = +25^\circ C$, and $V_{IN} = 600mV_{p-p}$, unless otherwise noted. $V_{DD} = 1.1V$ to $1.3V$, $T_A = 0^\circ C$ to $+85^\circ C$.

PARAMETER	SYMBOL	CONDITION	MIN	TYP	MAX	UNITS
Input LOW Logic Level	V_{IL}	DI, Clk, ENB	0	0	350	mV
Input HIGH Logic Level	V_{IH}	DI, Clk, ENB	750		V_{DD}	mV
Output LOW Logic Level	V_{OL}	LOS, DO	0	0	250	mV
Output HIGH Logic Level	V_{OH}	LOS, DO	1000		V_{DD}	mV
Input Current		Current draw on digital pin, i.e., CP[A,B], DI, Clk, ENB		30	100	μA

Electrical Specifications Typical values are at $V_{DD} = 1.2V$, $T_A = +25^\circ C$, and $V_{IN} = 600mV_{p-p}$, unless otherwise noted. $V_{DD} = 1.1V$ to $1.3V$, $T_A = 0^\circ C$ to $+85^\circ C$.

PARAMETER	SYMBOL	CONDITION	MIN	TYP	MAX	UNITS	NOTES
Supply Current	I_{DD}			111		mA	
Cable Input Amplitude Range	V_{IN}	Measured differentially at data source before encountering channel loss	600	1200	1600	mV_{p-p}	1
DC Differential Input Resistance		Measured on input channel IN	80	100	120	Ω	
DC Single-Ended Input Resistance		Measured on input channel IN[P] or IN[N]	40	50	60	Ω	
Input Return Loss (Differential)	S_{DD11}	100MHz to 7.5GHz	12			dB	2
Input Return Loss (Common Mode)	S_{CC11}	100MHz to 7.5GHz	7			dB	2
Input Return Loss (Com. to Diff. Conversion)	S_{DC11}	100MHz to 7.5GHz	35			dB	2
Output Amplitude Range	V_{OUT}	Measured differentially at OUT[P] and OUT[N] with 50 Ω load on both output pins	500	650	800	mV_{p-p}	
Differential Output Impedance		Measured on OUT	80	100	120	Ω	
Output Return Loss (Differential)	S_{DD22}	100MHz to 7.5GHz	10			dB	2
Output Return Loss (Common Mode)	S_{CC22}	100MHz to 7.5GHz	5			dB	2

Electrical Specifications Typical values are at $V_{DD} = 1.2V$, $T_A = +25^{\circ}C$, and $V_{IN} = 600mV_{p-p}$, unless otherwise noted.
 $V_{DD} = 1.1V$ to $1.3V$, $T_A = 0^{\circ}C$ to $+85^{\circ}C$. (Continued)

PARAMETER	SYMBOL	CONDITION	MIN	TYP	MAX	UNITS	NOTES
Output Return Loss (Com. to Diff. Conversion)	S_{DC22}	100MHz to 7.5GHz	32			dB	2
Output Residual Deterministic Jitter	DJ	10Gb/s; Up to 10m 28AWG standard twin-axial cable (approx. -27dB @ 5GHz); $1200mV_{p-p} \leq V_{IN} \leq 1600mV_{p-p}$		0.15		UI	1, 3, 4
Output Residual Deterministic Jitter	RJ	10Gb/s; Up to 10m 28AWG standard twin-axial cable (approx. -27dB @ 5GHz); $1200mV_{p-p} \leq V_{IN} \leq 1600mV_{p-p}$		1.3		$\mu SRMS$	1, 3, 4
Output Transition Time	t_r, t_f	20% to 80%		35		ps	5
Propagation Delay		From IN to OUT			500	ps	
LOS Assert Time		Time to assert Loss-of-Signal (LOS) indicator when transitioning from active data mode to line silence mode			50	μs	6
LOS De-Assert Time		Time to de-assert Loss-of-Signal (LOS) indicator when transitioning from line silence mode to active data mode			50	μs	6
Data-to-Line Silence Response Time		Time to transition from active data to line silence (muted output) on 10m 28AWG standard twin-axial cable at 10Gb/s			50	μs	6
Line Silence-to-Data Response Time		Time to transition from line silence mode (muted output) to active data on 10m 28AWG standard twin-axial cable at 10Gb/s			50	μs	6

NOTES:

1. After channel loss, differential amplitudes at QLx111GRx input must meet the input voltage range specified in "Absolute Maximum Ratings" on page 3.
2. Temperature = $+25^{\circ}C$, $V_{DD} = 1.2V$.
3. Output residual jitter is the difference between the total jitter at the lane extender output and the total jitter of the transmitted signal (as measured at the input to the channel). Total jitter (T_J) is $DJ_{pp} + 14.1 \times RJ_{RMS}$.
4. Measured using a PRBS 2^7-1 pattern. Deterministic jitter at the input to the lane extender is due to frequency-dependent, media-induced loss only.
5. Rise and fall times measured using a 1GHz clock with a 20ps edge rate.
6. For active data mode, cable input amplitude is $300mV_{p-p}$ (differential) or greater. For line silence mode, cable input amplitude is $20mV_{p-p}$ (differential) or less.

Typical Performance Characteristics

Performance is measured using the test setup illustrated in Figure 1. The signal from the pattern generator is launched into the twin-ax cable using an SMA adapter card. The chip evaluation board is connected to the output of the cable through another adapter card. The QLx111GRx output signal is then visualized on a scope to determine signal integrity parameters such as jitter (Note 7).

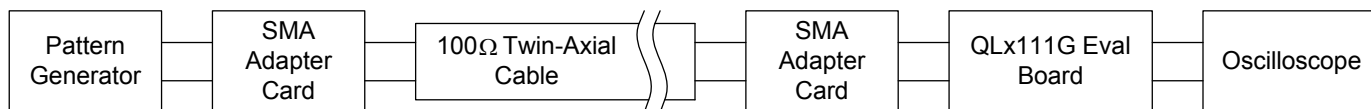

FIGURE 1. DEVICE CHARACTERIZATION SET UP

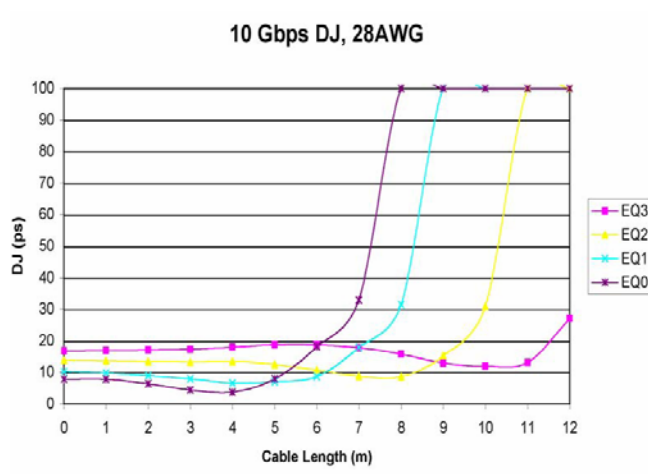

FIGURE 2. JITTER vs CABLE LENGTH AT 10Gb/s (BOOST LEVELS 0-3)

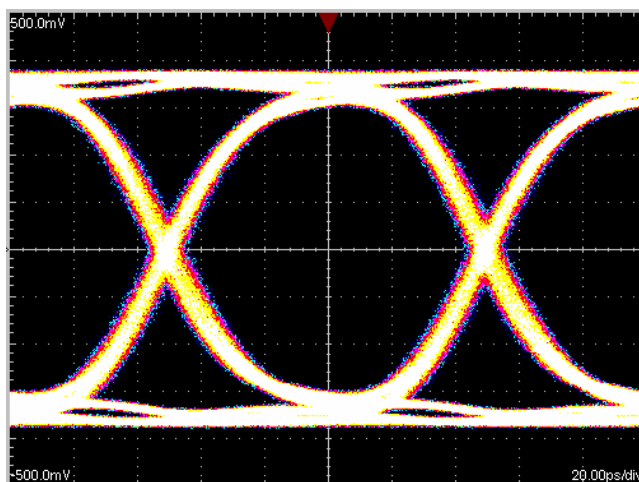

FIGURE 3. QLx111GRx 10Gb/s OUTPUT FOR A 10M 28AWG CABLE

NOTE:

- Prior to the tapeout, the data in Figures 2 and 3 represents simulations approximating the conditions of setup in Figure 1, not measured data.

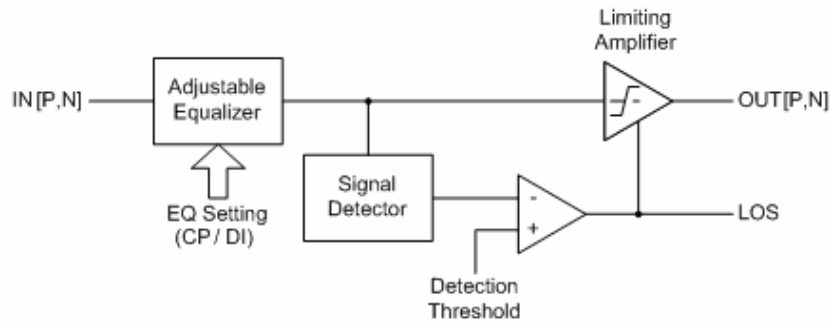

FIGURE 4. FUNCTIONAL DIAGRAM OF A SINGLE CHANNEL WITHIN THE QLx111GRx

Operation

The QLx111GRx is an advanced lane-extender for high-speed interconnects. A functional diagram of QLx111GRx is shown in Figure 4. In addition to a robust equalization filter to compensate for channel loss and restore signal fidelity, the QLx111GRx contains unique integrated features to preserve special signaling protocols typically broken by other equalizers. The signal detect function is used to mute the channel output when the equalized signal falls below the level determined by the Detection Threshold (DT) pin voltage. This function is intended to preserve periods of line silence (“quiescent state” in InfiniBand contexts). Furthermore, the output of the Signal Detect/DT comparator is used as a loss of signal (LOS) indicator to indicate the absence of a received signal.

As illustrated in Figure 4, the core of the high-speed signal path in the QLx111GRx is a sophisticated equalizer followed by a limiting amplifier. The equalizer compensates for skin loss, dielectric loss, and impedance discontinuities in the transmission channel. The equalizer is followed by a limiting amplification stage that provides a clean output signal with full amplitude swing and fast rise-fall times for reliable signal decoding in a subsequent receiver.

Adjustable Equalization Boost

QLx111GRx features a settable equalizer for custom signal restoration. The flexibility of this adjustable compensation architecture enables signal fidelity to be optimized on a channel-by-channel basis, providing support for a wide variety of channel characteristics and data rates ranging from 2.5Gb/s to 11.3Gb/s. Because the boost level is externally set rather than internally adapted, the QLx111GRx provides reliable communication from the very first bit transmitted. There is no time needed for adaptation and control loop convergence. Furthermore, there are no pathological data patterns that will cause the QLx111GRx to move to an incorrect boost level.

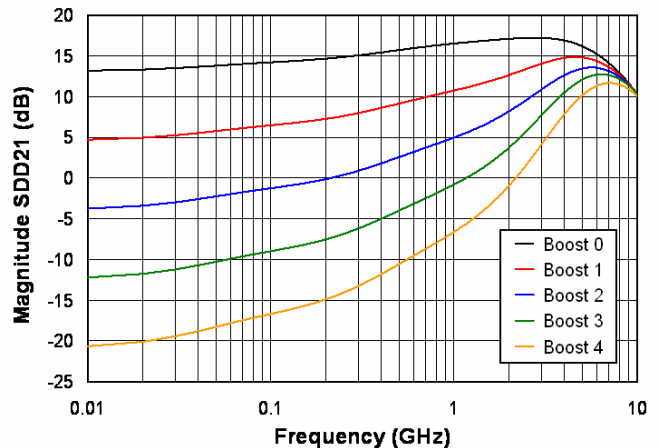

FIGURE 5. GAIN PROFILE FOR VARIOUS BOOST SETTINGS IN QLx111GRx

Control Pin Boost Setting

The connectivity of the CP pins are used to determine the boost level of QLx111GRx. Table 1 defines the mapping from the 2-bit CP word to the 5 available boost levels.

TABLE 1. MAPPING BETWEEN BOOST LEVEL AND CP-PIN CONNECTIVITY

CP[A]	CP[B]	BOOST LEVEL
No Connect	No Connect	0
No Connect	Gnd	1
No Connect	VDD	2
Gnd	No Connect	3
Gnd	Gnd	4

CML Input and Output Buffers

The input and output buffers for the high-speed data channel in the QLx111GRx are implemented using CML. Equivalent input and output circuits are shown in Figures 6 and 7.

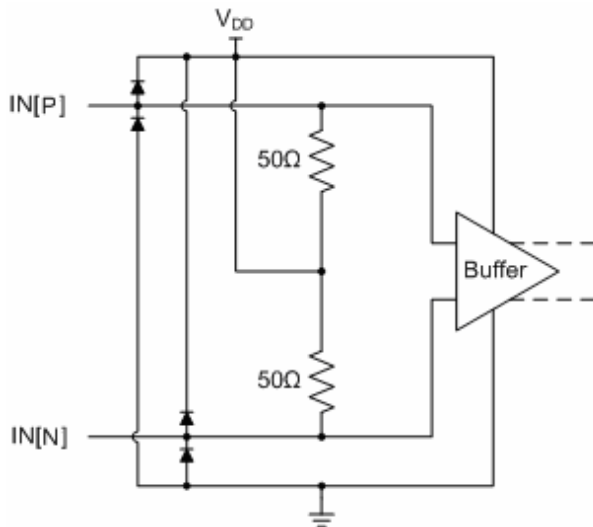

FIGURE 6. CML INPUT EQUIVALENT CIRCUIT FOR THE QLx111GRx

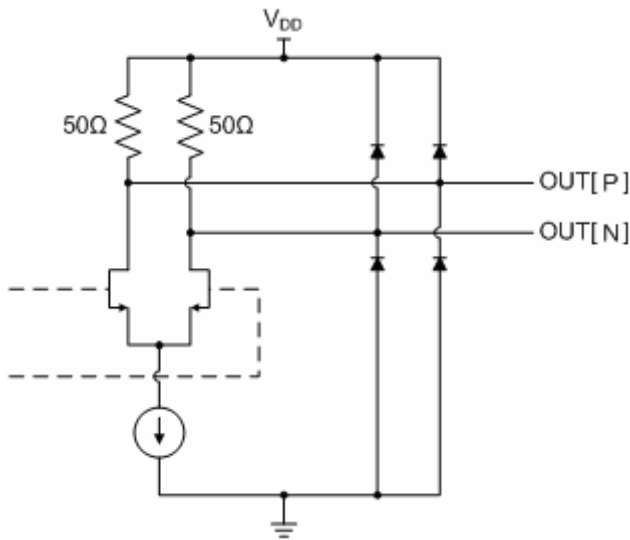

FIGURE 7. CML OUTPUT EQUIVALENT CIRCUIT FOR THE QLx111GRx

Line Silence/Quiescent Mode

Line silence is commonly broken by the limiting amplification in other equalizers. This disruption can be detrimental in many systems that rely on line silence as part of the protocol. The QLx111GRx contains special lane management capabilities to detect and preserve periods of line silence while still providing the fidelity-enhancing benefits of limiting amplification during active data transmission. Line silence is detected by measuring the amplitude of the equalized signal and comparing that to a threshold set by the voltage at the DT pin. When the amplitude falls below the threshold, the output driver stage is muted.

LOS Indicator

Pin LOS is used to output the state of the muting circuitry to serve as a loss of signal indicator for the device. This signal is directly derived from the muting signal off the DT-threshold signal detector output. The LOS signal goes HIGH when the power signal is below the DT threshold and LOW when the power goes above the DT threshold. This feature is meant to be used in optical systems (e.g. SFP+) where there are no quiescent or electrical-idle states. In these cases, the DT threshold is used to determine the sensitivity of the LOS indicator.

Detection Threshold (DT) Pin Functionality

The QLx111GRx is capable of maintaining periods of line silence by monitoring each channel for loss of signal (LOS) conditions and subsequently muting the outputs of a respective channel when such a condition is detected. A reference voltage applied to the detection threshold (DT) pin is used to set the LOS threshold of the internal signal detection circuitry. Voltage control on the DT pin is done via two external resistors. Both a pull-up and pull-down resistor are tied to the DT pin, with suggested values indicated in Figure 8. Other values of the resistors may also be applicable; therefore customers are advised to verify DT settings for their specific application.

Typical Application Reference Design

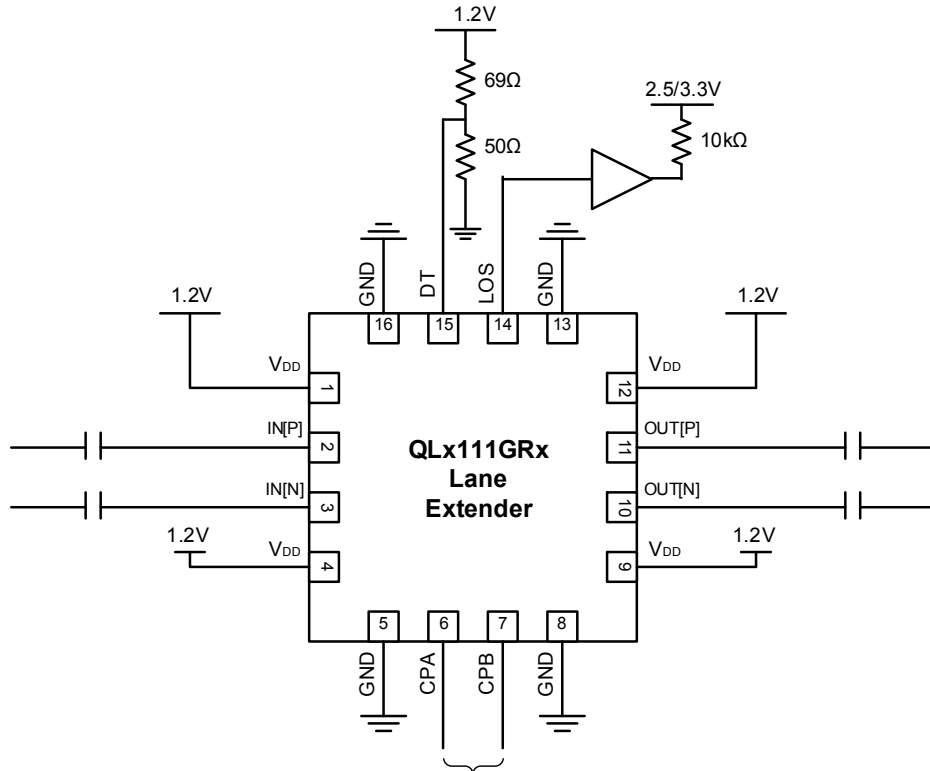

See Table 1 for setting CP Boost Level

FIGURE 8. TYPICAL APPLICATION REFERENCE DESIGN

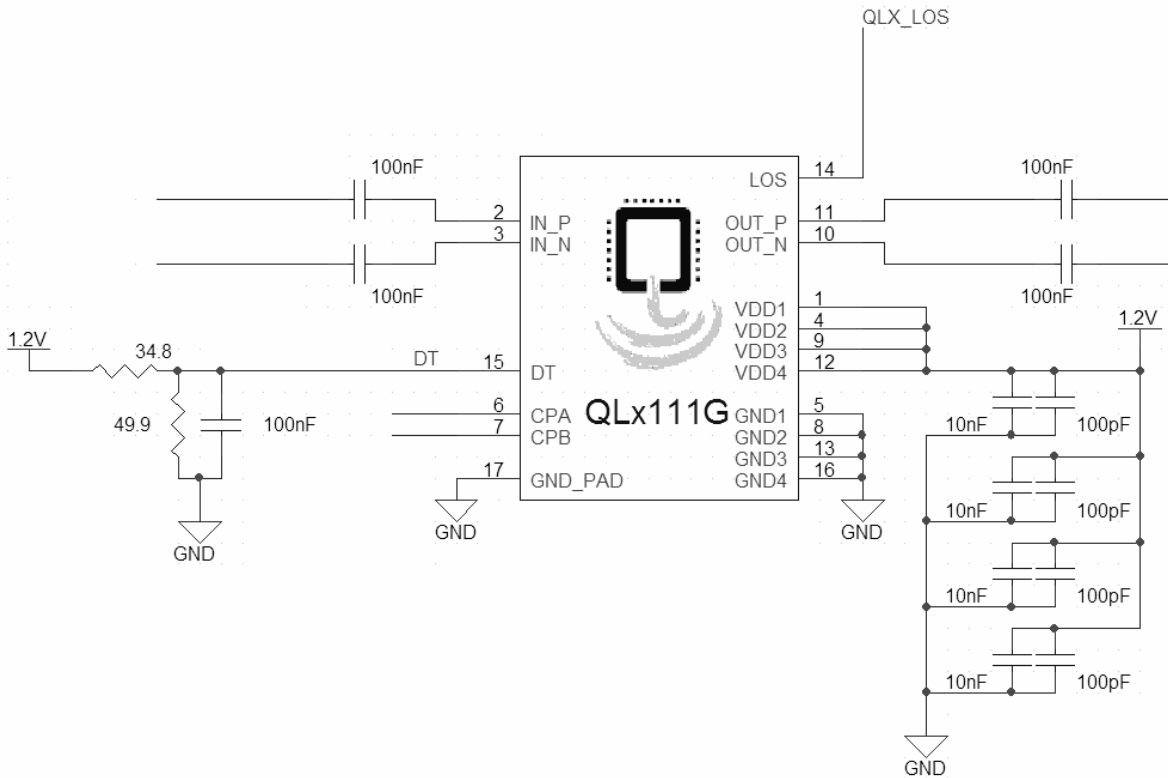

FIGURE 9. TYPICAL QLx111GRx APPLICATION SCHEMATIC

ABOUT Q:ACTIVE®

Intersil has long realized that to enable the complex server clusters of next generation datacenters, it is critical to manage the signal integrity issues of electrical interconnects. To address this, Intersil has developed its groundbreaking Q:ACTIVE® product line. By integrating its analog ICs inside cabling interconnects, Intersil is able to achieve unsurpassed improvements in reach, power consumption, latency, and cable gauge size as well as increased airflow in tomorrow's datacenters. This new technology transforms passive cabling into intelligent "roadways" that yield lower operating expenses and capital expenditures for the expanding datacenter.

Intersil Lane Extenders allow greater reach over existing cabling while reducing the need for thicker cables. This significantly reduces cable weight and clutter, increases airflow, and improves power consumption.

© Copyright Intersil Americas LLC 2009. All Rights Reserved.

All trademarks and registered trademarks are the property of their respective owners.

For additional products, see www.intersil.com/en/products.html

Intersil products are manufactured, assembled and tested utilizing ISO9001 quality systems as noted in the quality certifications found at www.intersil.com/en/support/qualandreliability.html

Intersil products are sold by description only. Intersil may modify the circuit design and/or specifications of products at any time without notice, provided that such modification does not, in Intersil's sole judgment, affect the form, fit or function of the product. Accordingly, the reader is cautioned to verify that datasheets are current before placing orders. Information furnished by Intersil is believed to be accurate and reliable. However, no responsibility is assumed by Intersil or its subsidiaries for its use; nor for any infringements of patents or other rights of third parties which may result from its use. No license is granted by implication or otherwise under any patent or patent rights of Intersil or its subsidiaries.

For information regarding Intersil Corporation and its products, see www.intersil.com

Package Outline Drawing

L16.3x3B

16 LEAD QUAD FLAT NO-LEAD PLASTIC PACKAGE

Rev 1, 4/07

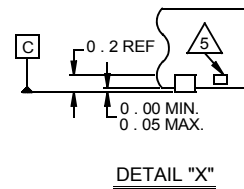
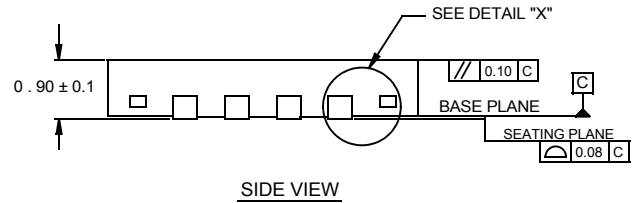
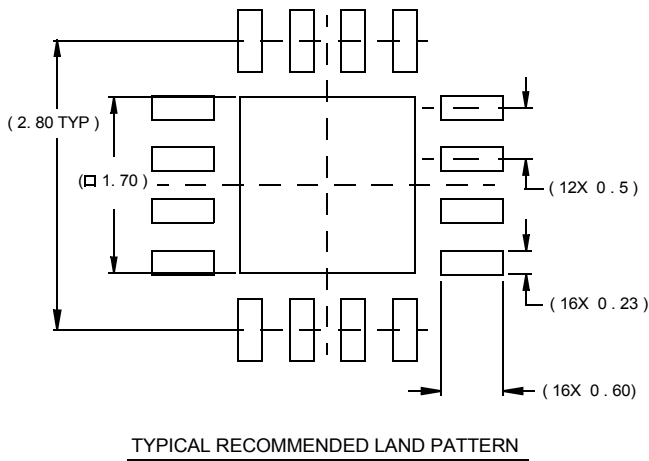
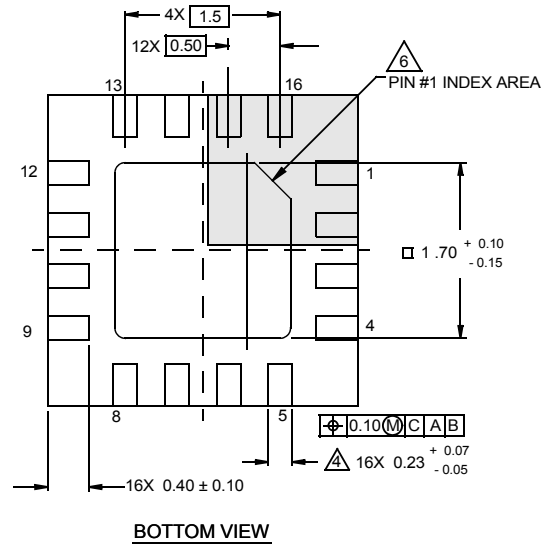
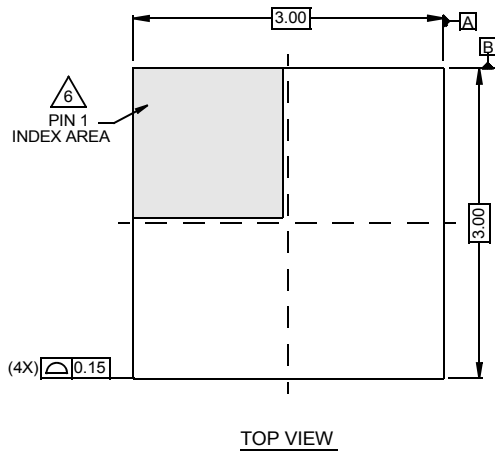

NOTES:

1. Dimensions are in millimeters.
Dimensions in () for Reference Only.
2. Dimensioning and tolerancing conform to AMSE Y14.5m-1994.
3. Unless otherwise specified, tolerance : Decimal ± 0.05
4. Dimension b applies to the metallized terminal and is measured between 0.15mm and 0.30mm from the terminal tip.
5. Tiebar shown (if present) is a non-functional feature.
6. The configuration of the pin #1 identifier is optional, but must be located within the zone indicated. The pin #1 identifier may be either a mold or mark feature.