

FEATURES:

- N channel FET switches with no parasitic diode to Vcc
 - Isolation under power-off conditions
 - No DC path to Vcc or GND
 - 5V tolerant in OFF and ON state
- 5V tolerant I/Os
- Low RON - 4Ω typical
- Flat RON characteristics over operating range
- Rail-to-rail switching 0 - 5V
- Bidirectional dataflow with near-zero delay: no added ground bounce
- Excellent RON matching between channels
- VCC operation: 2.3V to 3.6V
- High bandwidth - up to 500MHz
- LVTTTL-compatible control Inputs
- Undershoot Clamp Diodes on all switch and control Inputs
- Low I/O capacitance, 4pF typical
- Available in 40-pin QVSOP package

APPLICATIONS:

- Hot-swapping
- 10/100 Base-T, Ethernet LAN switch
- Low distortion analog switch
- Replaces mechanical relay
- ATM 25/155 switching

DESCRIPTION:

The QS32XVH245 HotSwitch is a high bandwidth, 16-bit bus switch. The QS32XVH245 has very low ON resistance, resulting in under 250ps propagation delay through the switch. The switches can be turned ON under the control of the LVTTTL-compatible Output Enable ($\overline{OE}x$) signal for bidirectional data flow with no added delay or ground bounce. In the ON state, the switches can pass signals up to 5V. In the OFF state, the switches offer very high impedance at the terminals.

The combination of near-zero propagation delay, high OFF impedance, and over-voltage tolerance makes the QS32XVH245 ideal for high performance communications applications.

The QS32XVH245 is characterized for operation from -40°C to +85°C.5°C.

FUNCTIONAL BLOCK DIAGRAM

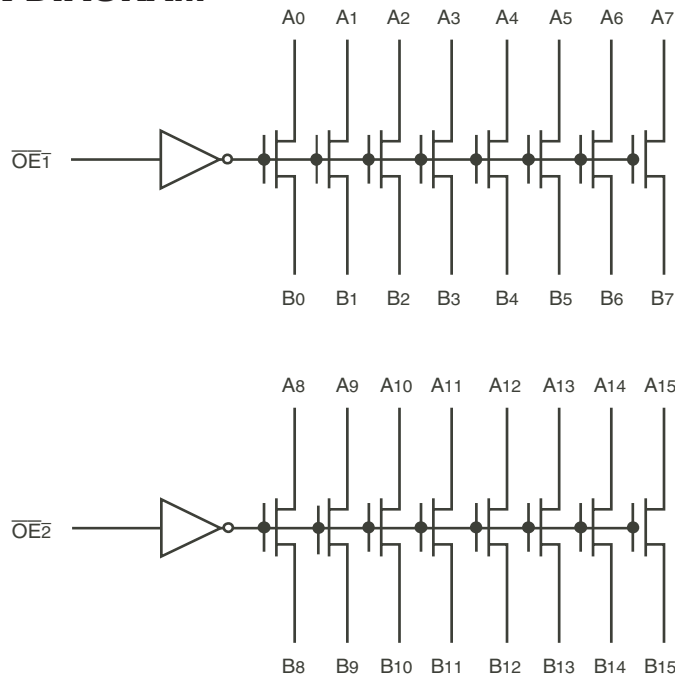

PIN CONFIGURATION

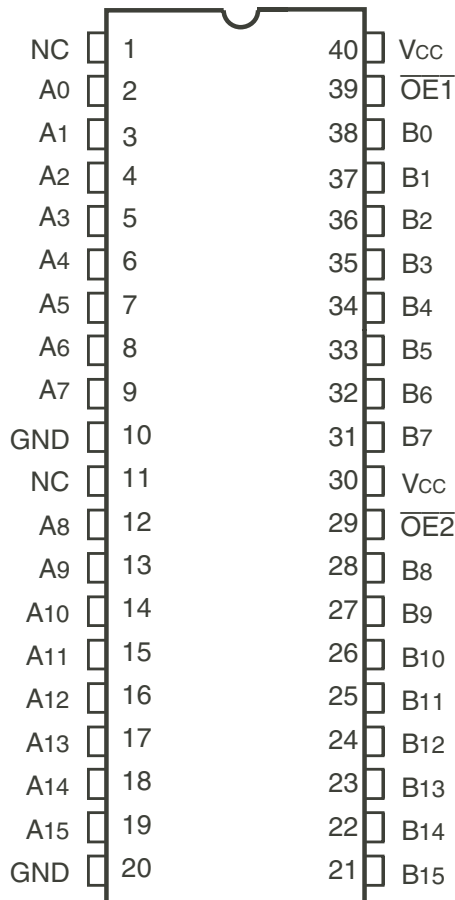

QVSOP
TOP VIEW

ABSOLUTE MAXIMUM RATINGS⁽¹⁾

| Symbol | Description | Max | Unit |
|----------------------|---|--------------|------|
| VTERM ⁽²⁾ | Supply Voltage to Ground | -0.5 to +4.6 | V |
| VTERM ⁽³⁾ | DC Switch Voltage V _s | -0.5 to +5.5 | V |
| VTERM ⁽³⁾ | DC Input Voltage V _{IN} | -0.5 to +5.5 | V |
| VAC | AC Input Voltage (pulse width ≤20ns) | -3 | V |
| I _{OUT} | DC Output Current (max. sink current/pin) | 120 | mA |
| T _{STG} | Storage Temperature | -65 to +150 | °C |

NOTES:

- Stresses greater than those listed under ABSOLUTE MAXIMUM RATINGS may cause permanent damage to the device. This is a stress rating only and functional operation of the device at these or any other conditions above those indicated in the operational sections of this specification is not implied. Exposure to absolute maximum rating conditions for extended periods may affect reliability.
- V_{CC} terminals.
- All terminals except V_{CC}.

CAPACITANCE (T_A = +25°C, F = 1MHz, V_{IN} = 0V, V_{OUT} = 0V)

| Symbol | Parameter ⁽¹⁾ | Typ. | Max. | Unit |
|------------------|-----------------------------------|------|------|------|
| C _{IN} | Control Inputs | 3 | 5 | pF |
| C _{I/O} | Quickswitch Channels (Switch OFF) | 4 | 6 | pF |
| C _{I/O} | Quickswitch Channels (Switch ON) | 8 | 12 | pF |

NOTE:

- This parameter is guaranteed but not production tested.

PIN DESCRIPTION

| Pin Names | I/O | Description |
|------------------|-----|---------------|
| \overline{OEx} | I | Output Enable |
| A _x | I/O | Bus A |
| B _x | I/O | Bus B |

FUNCTION TABLE⁽¹⁾

| \overline{OEx} | Function |
|------------------|--|
| H | Disconnect |
| L | Connect (A _x = B _x) |

NOTE:

- H = HIGH Voltage Level
L = LOW Voltage Level

DC ELECTRICAL CHARACTERISTICS OVER OPERATING RANGE

Following Conditions Apply Unless Otherwise Specified:

Industrial: $T_A = -40^{\circ}\text{C}$ to $+85^{\circ}\text{C}$, $V_{CC} = 3.3\text{V} \pm 0.3\text{V}$

| Symbol | Parameter | Test Conditions | | | Min. | Typ. ⁽¹⁾ | Max. | Unit |
|-----------|--|---|---|------------------------|------|---------------------|---------|---------------|
| V_{IH} | Input HIGH Voltage | Guaranteed Logic HIGH for Control Inputs | $V_{CC} = 2.3\text{V}$ to 2.7V | | 1.7 | — | — | V |
| | | | $V_{CC} = 2.7\text{V}$ to 3.6V | | 2 | — | — | |
| V_{IL} | Input LOW Voltage | Guaranteed Logic LOW for Control Inputs | $V_{CC} = 2.3\text{V}$ to 2.7V | | — | — | 0.7 | V |
| | | | $V_{CC} = 2.7\text{V}$ to 3.6V | | — | — | 0.8 | |
| I_{IN} | Input Leakage Current (Control Inputs) | $0\text{V} \leq V_{IN} \leq V_{CC}$ | | | — | — | ± 1 | μA |
| I_{OZ} | Off-State Current (Hi-Z) | $0\text{V} \leq V_{OUT} \leq 5\text{V}$, Switches OFF | | | — | — | ± 1 | μA |
| I_{OFF} | Data Input/Output Power Off Leakage | V_{IN} or V_{OUT} 0V to 5V , $V_{CC} = 0\text{V}$ | | | — | — | ± 1 | μA |
| R_{ON} | Switch ON Resistance | $V_{CC} = 2.3\text{V}$ Typical at $V_{CC} = 2.5\text{V}$ | $V_{IN} = 0\text{V}$ | $I_{ON} = 30\text{mA}$ | — | 6 | 8 | Ω |
| | | | $V_{IN} = 1.7\text{V}$ | $I_{ON} = 15\text{mA}$ | — | 7 | 9 | |
| | | $V_{CC} = 3\text{V}$ | $V_{IN} = 0\text{V}$ | $I_{ON} = 30\text{mA}$ | — | 4 | 6 | |
| | | | $V_{IN} = 2.4\text{V}$ | $I_{ON} = 15\text{mA}$ | — | 5 | 8 | |

NOTE:

1. Typical values are at $V_{CC} = 3.3\text{V}$ and $T_A = 25^{\circ}\text{C}$.

TYPICAL ON RESISTANCE vs V_{IN} AT $V_{CC} = 3.3\text{V}$

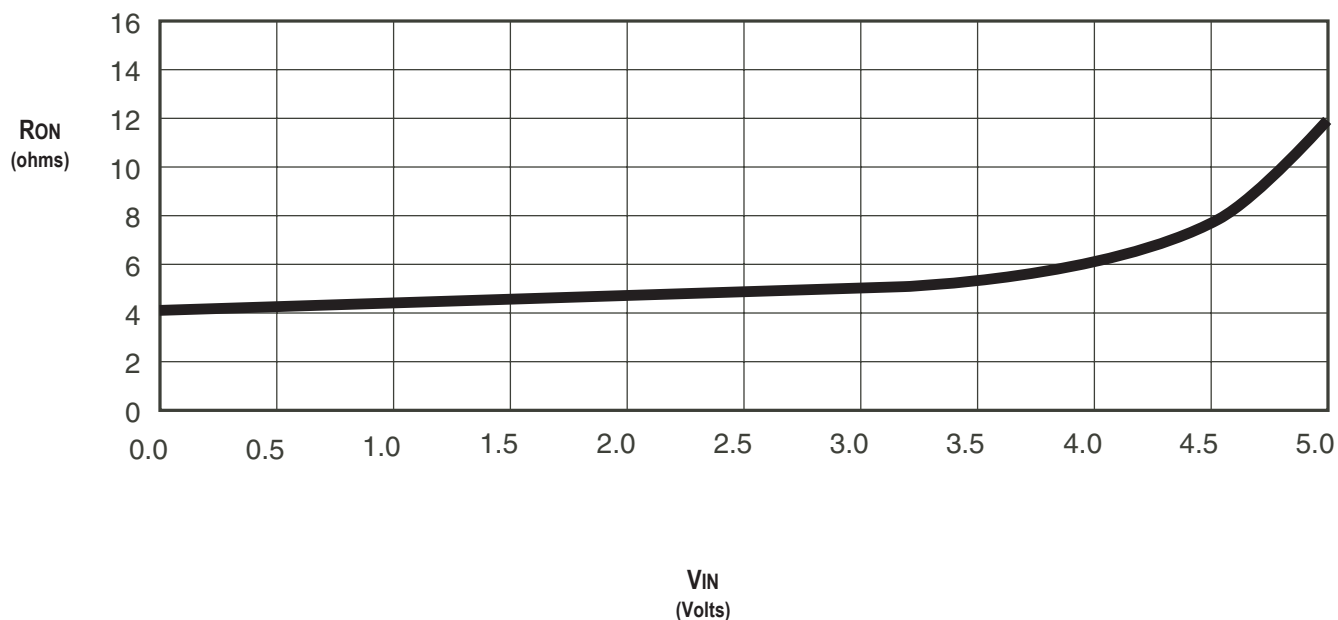

POWER SUPPLY CHARACTERISTICS

| Symbol | Parameter | Test Conditions ⁽¹⁾ | Min. | Typ. | Max. | Unit |
|------------------|---|---|--|------|------|------|
| I _{CCQ} | Quiescent Power Supply Current | V _{CC} = Max., V _{IN} = GND or V _{CC} , f = 0 | — | 4 | 8 | mA |
| ΔI _{CC} | Power Supply Current ^(2,3) per Input HIGH | V _{CC} = Max., V _{IN} = 3V, f = 0 per Control Input | — | — | 30 | μA |
| I _{CCD} | Dynamic Power Supply Current per Output Enable Control Input ⁽⁴⁾ | V _{CC} = 3.3V, A and B Pins Open, Control Inputs Toggling @ 50% Duty Cycle | See Typical I _{CCD} vs Enable Frequency graph below | | | |

NOTES:

1. For conditions shown as Min. or Max., use the appropriate values specified under DC Electrical Characteristics.
2. Per input driven at the specified level. A and B pins do not contribute to ΔI_{CC}.
3. This parameter is guaranteed but not tested.
4. This parameter represents the current required to switch internal capacitance at the specified frequency. The A and B inputs do not contribute to the Dynamic Power Supply Current. This parameter is guaranteed but not production tested.

TYPICAL I_{CCD} vs ENABLE FREQUENCY CURVE AT V_{CC} = 3.3V

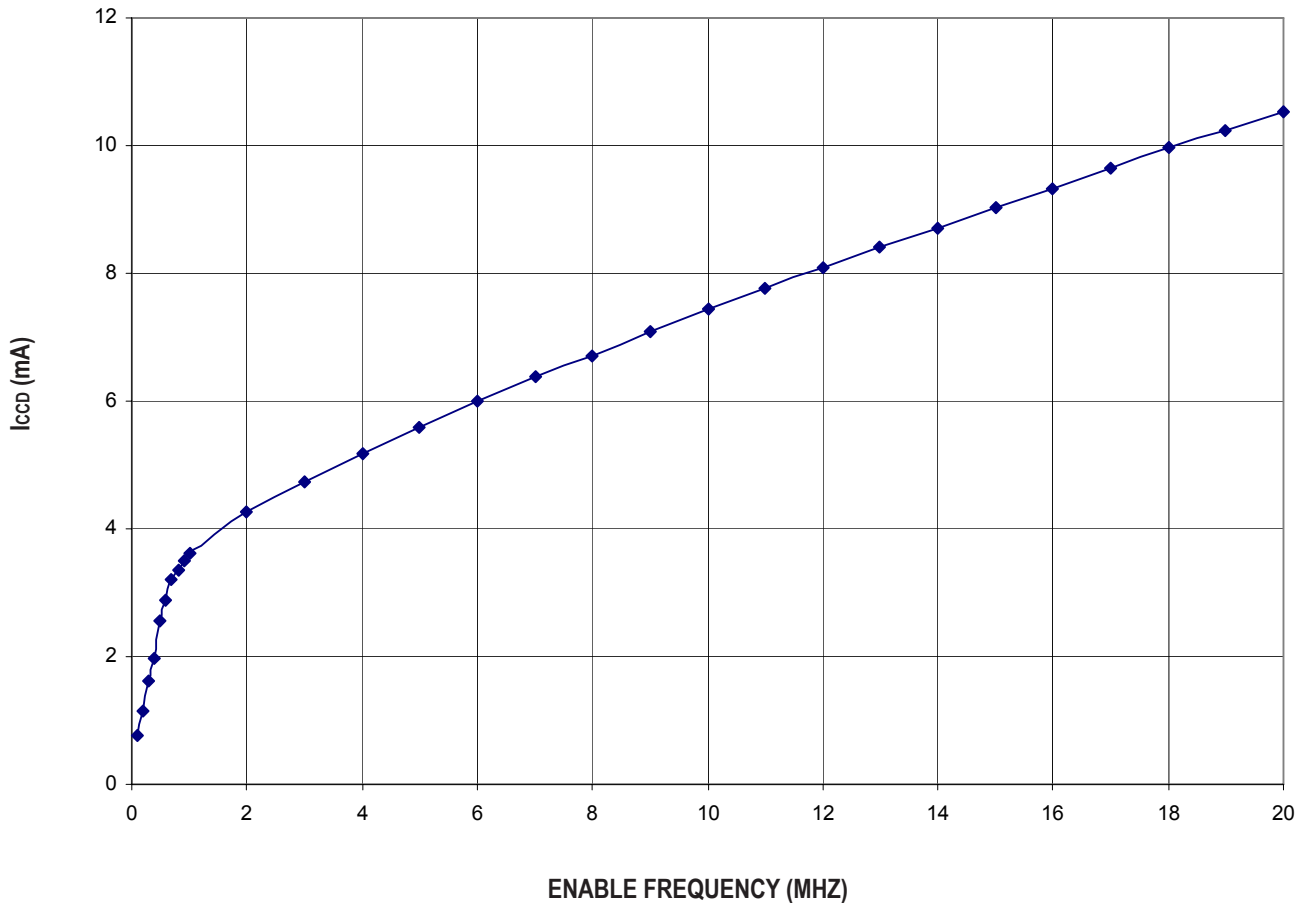

SWITCHING CHARACTERISTICS OVER OPERATING RANGE

T_A = -40°C to +85°C

| Symbol | Parameter | V _{CC} = 2.5 ± 0.2V ⁽¹⁾ | | V _{CC} = 3.3 ± 0.3V ⁽¹⁾ | | Unit |
|------------------|---|---|------|---|------|------|
| | | Min. ⁽⁴⁾ | Max. | Min. ⁽⁴⁾ | Max. | |
| t _{PLH} | Data Propagation Delay ^(2,3) | — | 0.2 | — | 0.2 | ns |
| t _{PHL} | Ax to/from Bx | | | | | |
| t _{PZL} | Switch Turn-On Delay | 1.5 | 8 | 1.5 | 7 | ns |
| t _{PZH} | OEx to Ax/Bx | | | | | |
| t _{PLZ} | Switch Turn-Off Delay | 1.5 | 7 | 1.5 | 6.5 | ns |
| t _{PHZ} | OEx to Ax/Bx | | | | | |
| f _{OEx} | Operating Frequency - Enable ^(2,5) | — | 10 | — | 20 | MHz |

NOTES:

1. See Test Conditions under TEST CIRCUITS AND WAVEFORMS.
2. This parameter is guaranteed but not production tested.
3. The bus switch contributes no propagation delay other than the RC delay of the ON resistance of the switch and the load capacitance. The time constant for the switch alone is of the order of 0.2ns at C_L = 50pF. Since this time constant is much smaller than the rise and fall times of typical driving signals, it adds very little propagation delay to the system. Propagation delay of the bus switch, when used in a system, is determined by the driving circuit on the driving side of the switch and its interaction with the load on the driven side.
4. Minimums are guaranteed but not production tested.
5. Maximum toggle frequency for OEx control input (pass voltage > V_{CC}, V_{IN} = 5V, R_{LOAD} ≥ 1MΩ, no C_{LOAD}).

SOME APPLICATIONS FOR HOTSWITCH PRODUCTS

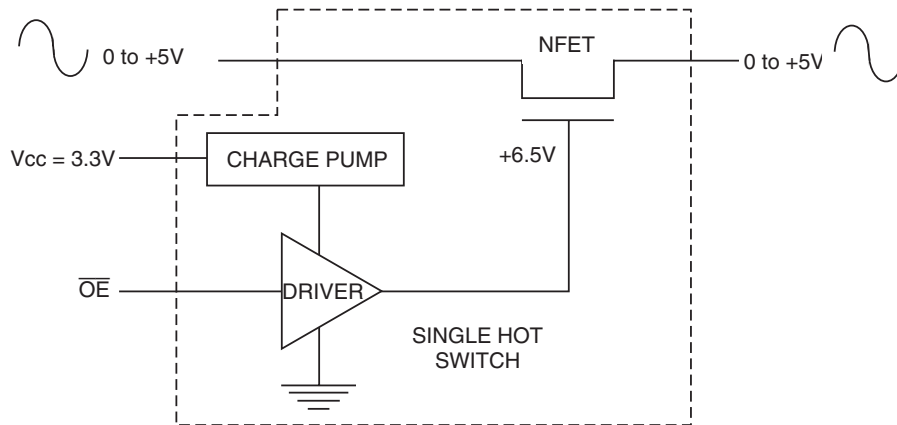

Rail-to-Rail Switching

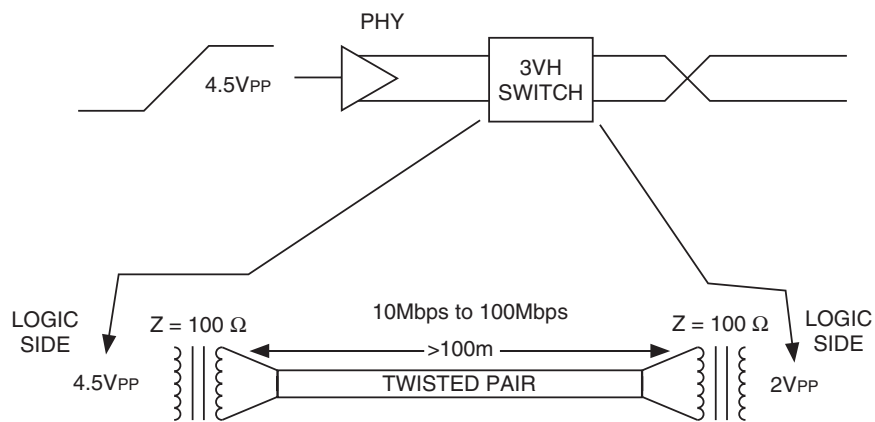

Fast Ethernet Data Switching (LAN Switch)

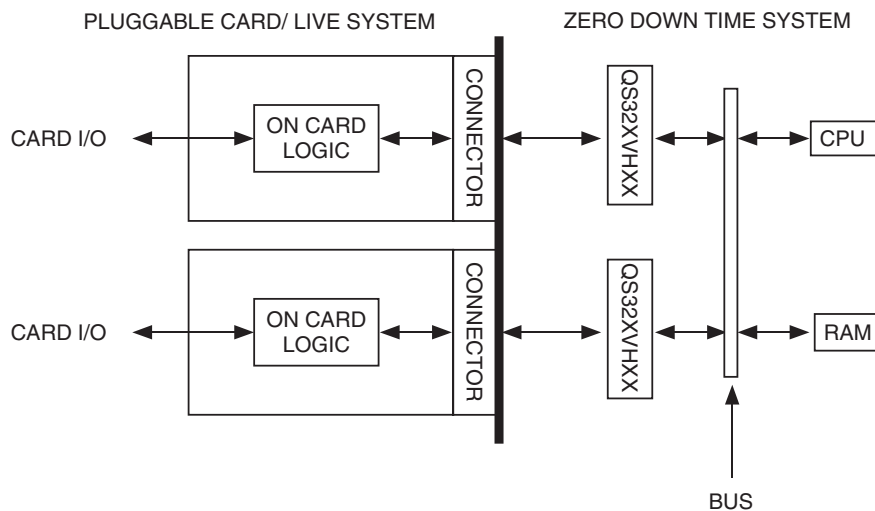

Hot-Swapping

TEST CIRCUITS AND WAVEFORMS

TEST CONDITIONS

| Symbol | Vcc ⁽¹⁾ = 3.3V ± 0.3V | Vcc ⁽²⁾ = 2.5V ± 0.2V | Unit |
|-------------------|----------------------------------|----------------------------------|------|
| V _{LOAD} | 6 | 2 x V _{cc} | V |
| V _{IH} | 3 | V _{cc} | V |
| V _T | 1.5 | V _{cc} /2 | V |
| V _{LZ} | 300 | 150 | mV |
| V _{HZ} | 300 | 150 | mV |
| C _L | 50 | 30 | pF |

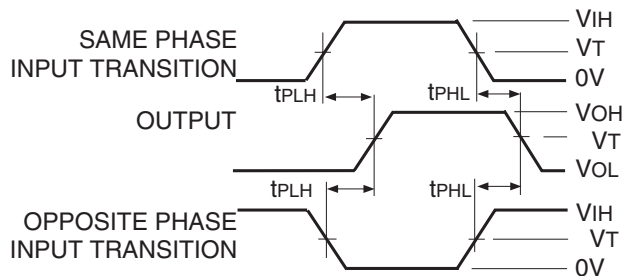

Propagation Delay

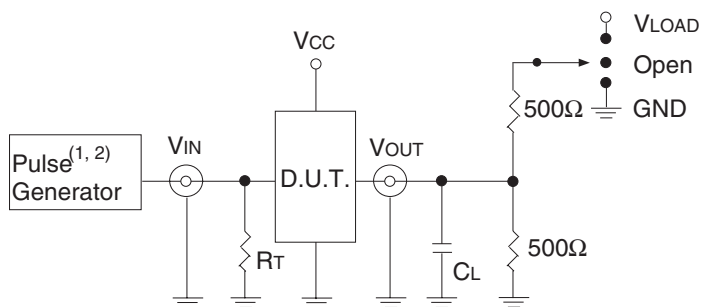

Test Circuits for All Outputs

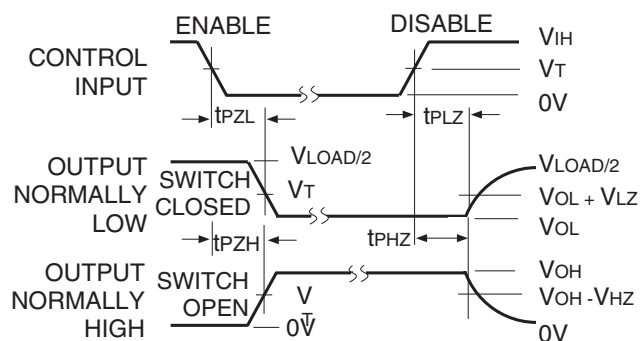

NOTE:

1. Diagram shown for input Control Enable-LOW and input Control Disable-HIGH.

Enable and Disable Times

DEFINITIONS:

C_L = Load capacitance: includes jig and probe capacitance.

R_T = Termination resistance: should be equal to Z_{OUT} of the Pulse Generator.

NOTES:

1. Pulse Generator for All Pulses: Rate ≤ 10MHz; t_r ≤ 2.5ns; t_r ≤ 2.5ns.

2. Pulse Generator for All Pulses: Rate ≤ 10MHz; t_r ≤ 2ns; t_r ≤ 2ns.

SWITCH POSITION

| Test | Switch |
|------------------------------------|-------------------|
| t _{PLZ} /t _{PZL} | V _{LOAD} |
| t _{PHZ} /t _{PZH} | GND |
| t _{PD} | Open |

ORDERING INFORMATION

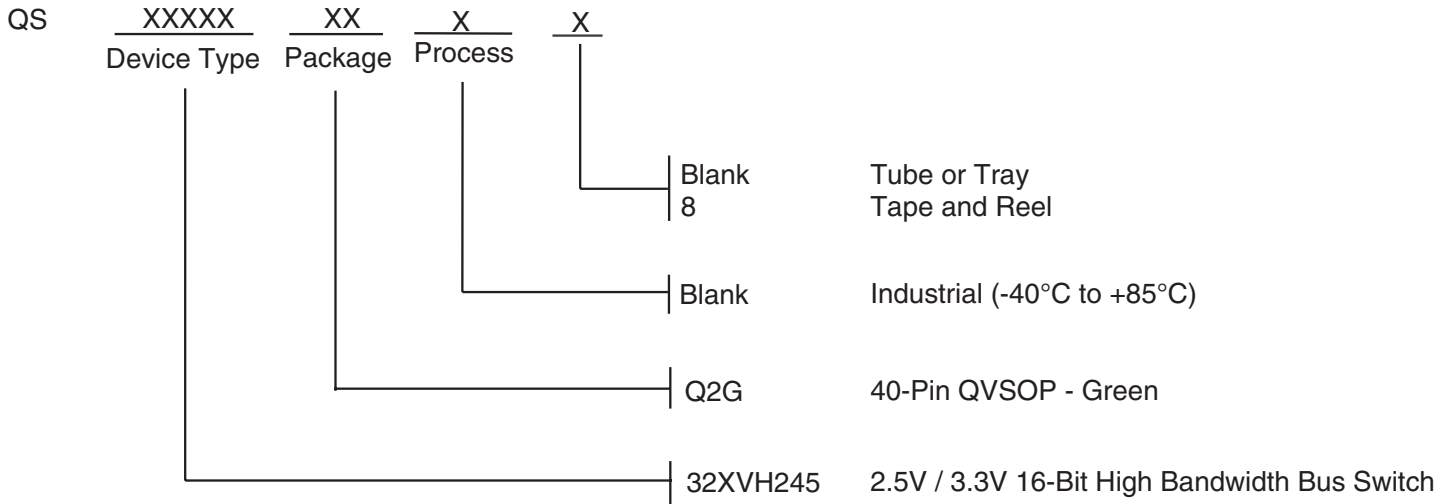

Datasheet Document History

| | | |
|----------|----------|---|
| 09/01/08 | Pg. 4, 8 | Revise ICCQ Typ. and Max. Remove non green package version and updated the ordering information by removing the "IDT" notation. |
| 06/14/11 | Pg. 8 | Updated ordering information to include tube or tray and tape & reel. |

IMPORTANT NOTICE AND DISCLAIMER

RENESAS ELECTRONICS CORPORATION AND ITS SUBSIDIARIES (“RENESAS”) PROVIDES TECHNICAL SPECIFICATIONS AND RELIABILITY DATA (INCLUDING DATASHEETS), DESIGN RESOURCES (INCLUDING REFERENCE DESIGNS), APPLICATION OR OTHER DESIGN ADVICE, WEB TOOLS, SAFETY INFORMATION, AND OTHER RESOURCES “AS IS” AND WITH ALL FAULTS, AND DISCLAIMS ALL WARRANTIES, EXPRESS OR IMPLIED, INCLUDING, WITHOUT LIMITATION, ANY IMPLIED WARRANTIES OF MERCHANTABILITY, FITNESS FOR A PARTICULAR PURPOSE, OR NON-INFRINGEMENT OF THIRD-PARTY INTELLECTUAL PROPERTY RIGHTS.

These resources are intended for developers who are designing with Renesas products. You are solely responsible for (1) selecting the appropriate products for your application, (2) designing, validating, and testing your application, and (3) ensuring your application meets applicable standards, and any other safety, security, or other requirements. These resources are subject to change without notice. Renesas grants you permission to use these resources only to develop an application that uses Renesas products. Other reproduction or use of these resources is strictly prohibited. No license is granted to any other Renesas intellectual property or to any third-party intellectual property. Renesas disclaims responsibility for, and you will fully indemnify Renesas and its representatives against, any claims, damages, costs, losses, or liabilities arising from your use of these resources. Renesas' products are provided only subject to Renesas' Terms and Conditions of Sale or other applicable terms agreed to in writing. No use of any Renesas resources expands or otherwise alters any applicable warranties or warranty disclaimers for these products.

(Disclaimer Rev.1.01 Jan 2024)

Corporate Headquarters

TOYOSU FORESIA, 3-2-24 Toyosu,
Koto-ku, Tokyo 135-0061, Japan
www.renesas.com

Trademarks

Renesas and the Renesas logo are trademarks of Renesas Electronics Corporation. All trademarks and registered trademarks are the property of their respective owners.

Contact Information

For further information on a product, technology, the most up-to-date version of a document, or your nearest sales office, please visit www.renesas.com/contact-us/.