

REAC1251G

Low Input Offset Voltage $V_{IO} \leq 1\text{mV}$

Single Power Supply Dual Operational Amplifiers

DESCRIPTION

The REAC1251G is a single power and dual operational amplifiers which has features low input offset voltage $V_{IO} \leq \pm 1\text{mV}$ and low input offset voltage temperature drift. The features include low-voltage operation, a common-mode input voltage that range from V^- (GND) level, an output from a V^- (GND) level that is determined by the output stage of class C push-pull circuit and a $50 \mu\text{A}$ (TYP.) constant current, and a low current consumption.

In addition to that, this amplifier can also operate in both positive and negative power supply and can be used extensively in various amplifier circuits.

Features

- Low input offset voltage $\pm 1\text{mV}$ (Max.)
- Low input offset voltage temperature drift $\pm 1\mu\text{V}/^\circ\text{C}$ (Typ.)
- The package line-up is MSOP

ORDERING INFORMATION

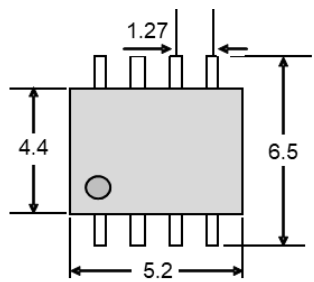
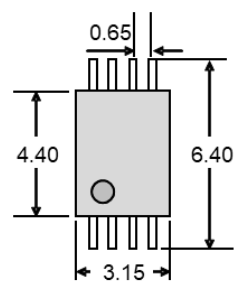
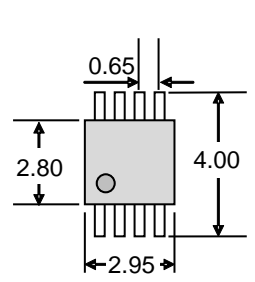
Package	Standard SOP	TSSOP	MSOP
Subject Part Number	REAC1251GSM#GCA	REAC1251GSP#GC0	REAC1251GSN#GC0
Product Type Quality Level	Normal Quality Level		
Outline Comparison	Unit : mm 	Unit : mm 	Unit : mm 
(Mounting Area Ratio)	(100 %)	(60 %)	(35 %)

PIN CONFIGURATION (Marking Side)

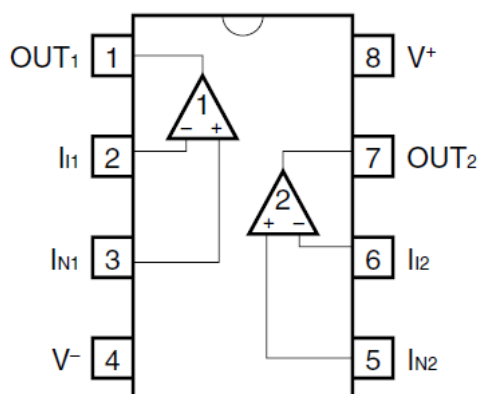

ABSOLUTE MAXIMUM RATINGS

<T_A=25°C>

Parameter	Symbol	REAC1251GSM	REAC1251GSP	REAC1251GSN	Unit
Power Supply Voltage ^{Note.1}	V ⁺ - V ⁻	-0.3 to +32			V
Differential Input Voltage	V _{ID}	±10			V
Input Voltage ^{Note.2}	V _I	V ⁻ -0.3 to V ⁻ +32			V
Output applied Voltage ^{Note.3}	V _O	V ⁻ -0.3 to V ⁺ +0.3			V
Total Power Dissipation ^{Note.4}	P _T	440			mW
Output Short Circuit Duration ^{Note.5}	t _s	Indefinite			s
Operating Ambient Temperature	T _A	-40 to +85	-40 to +125		°C
Storage Temperature	T _{stg}	-55 to +125	-55 to +150		°C

Note

- Note that reverse connections of the power supply may damage ICs.
- The input voltage is allowed to input without damage or destruction independent of the magnitude of V⁺. Either input signal is not allowed to go negative by more than 0.3 V if the conditions are within absolute maximum ratings. This specification which includes the transition state such as electric power ON/OFF must be kept. In addition, the input voltage that operates normally as an operational amplifier is within the Common Mode Input Voltage range of an electrical characteristic.
- A range where input voltage can be applied to an output pin externally with no deterioration or damage to the feature (characteristic). The input voltage can be applied regardless of the electric supply voltage. This specification which includes the transition state such as electric power ON/OFF must be kept.
- This is the value of when the glass epoxy substrate (size: 100 mm x 100 mm, thickness: 1 mm, 15% of the substrate area where only one side is copper foiled is filling wired) is mounted. Note that restrictions will be made to the following conditions for each product, and the derating ratio depending on the operating ambient temperature.

REAC1251JSM Derate at -4.4 mW/°C when T_A > 25°C.

Junction ambient thermal resistance R_{th(J-A)}=227°C/W

REAC1251JSP Derate at -5.5 mW/°C when T_A > 69°C.

Junction ambient thermal resistance R_{th(J-A)}=183°C/W

REAC1251JSN Derate at -4.8 mW/°C when T_A > 58°C.

Junction ambient thermal resistance R_{th(J-A)}=208°C/W

- Short circuits from the output to V⁺ can cause destruction. Pay careful attention to the total power dissipation not to exceed the absolute maximum ratings, Note 4.

RECOMMENDED OPERATING CONDITIONS

Parameter	Symbol	MIN.	TYP.	MAX.	Unit
Power Supply Voltage (Split)	V^{\pm}	± 1.5		± 15	V
Power Supply Voltage ($V^- = \text{GND}$)	V^+	+3		+30	V

ELECTRICAL CHARACTERISTICS< $V^+ = +5\text{V}$, $V^- = \text{GND}$, $T_A = 25^\circ\text{C}$ >

Parameter	Symbol	MIN.	TYP.	MAX.	Unit	Conditions
Input Offset Voltage	V_{IO}		± 0.2	± 1	mV	$V_{IN} = 1/2V_{CC}$, $R_S \leq 50\Omega$
Input Offset Current	I_{IO}		± 5	± 50	nA	
Input Bias Current ^{Note 6}	I_B		14	60	nA	
Large Signal Voltage Gain	A_V	25,000	100,000			$R_L \geq 2\text{k}\Omega$ (Connect to GND)
Supply Current ^{Note 7}	I_{CC}		0.7	1.4	mA	$R_L = \infty$, $I_O = 0\text{A}$
Common Mode Rejection Ratio	CMR	65	85		dB	
Supply Voltage Rejection Ratio	SVR	65	100		dB	
Common Mode Input Voltage Range	V_{ICM}	0		$V^+ - 1.5$	V	
Output Voltage Swing	V_O	0		$V^+ - 1.6$	V	$R_L = 2\text{k}\Omega$ (Connect to GND)
Output Current (Source)	$I_{O \text{ SOURCE}}$	20	40		mA	$V_{IN^+} = +1\text{V}$, $V_{IN^-} = 0\text{V}$
Output Current (Sink)	$I_{O \text{ SINK1}}$	10	20		mA	$V_{IN^-} = +1\text{V}$, $V_{IN^+} = 0\text{V}$
	$I_{O \text{ SINK2}}$	12	50		μA	$V_{IN^-} = +1\text{V}$, $V_{IN^+} = 0\text{V}$, $V_O = 200\text{mV}$
Channel Separation			120		dB	$f = 1\text{kHz}$ to 20kHz

Note 6. The input bias current flows in the direction where the IC flows out because the first stage is configured with a PNP transistor.

7. This is a current that flows in the internal circuit. This current will flow irrespective of the channel used.

TYPICAL PERFORMANCE CHARACTERISTICS (T_A = 25 °C, TYP.) (Reference value)

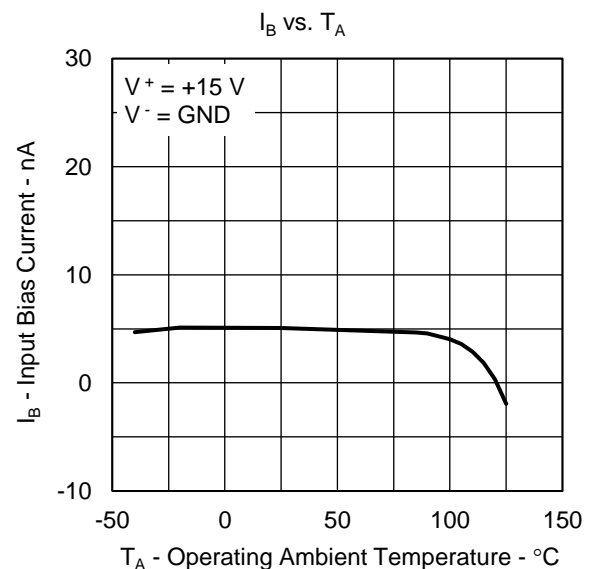
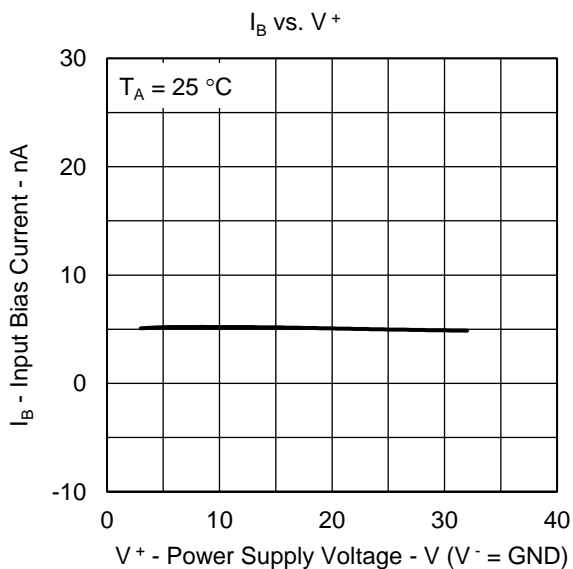
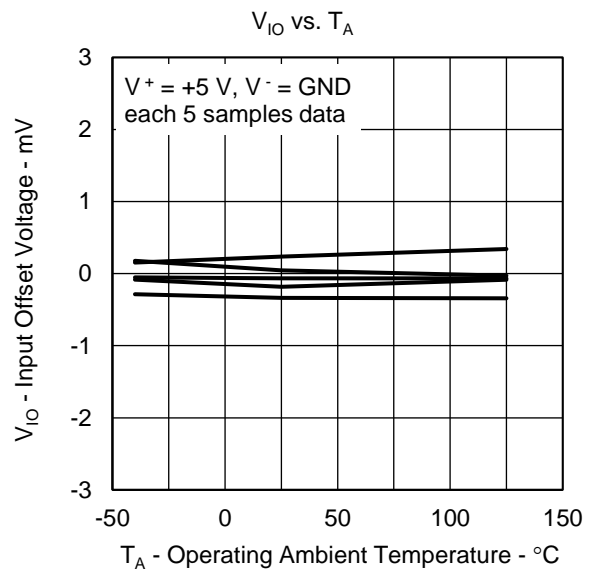
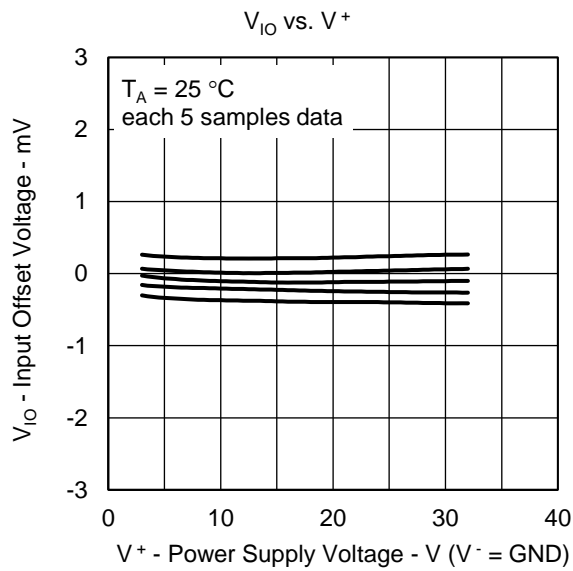
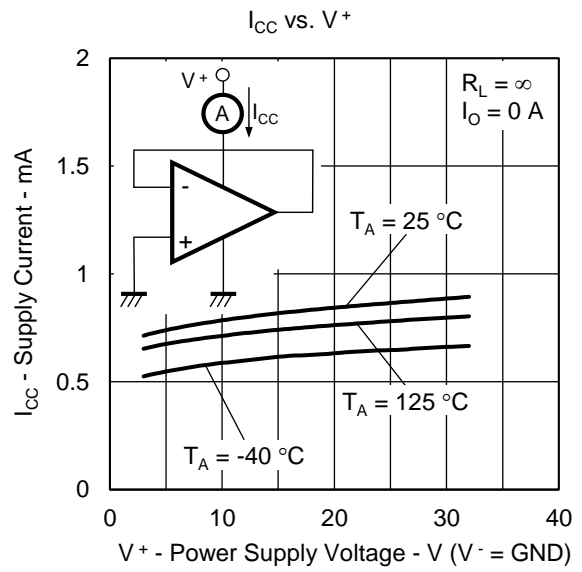
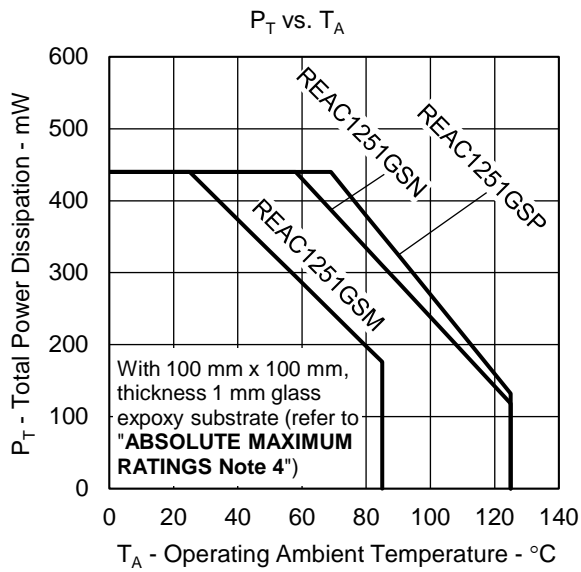

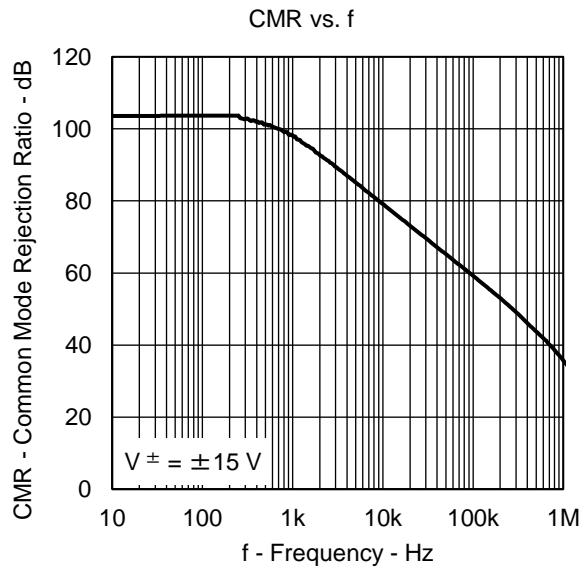
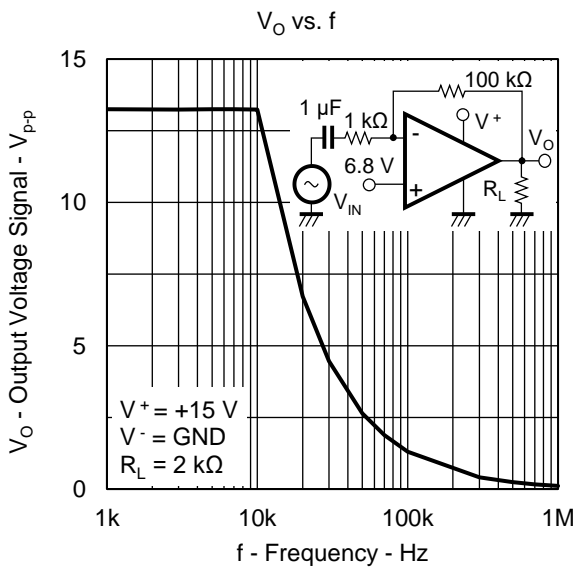
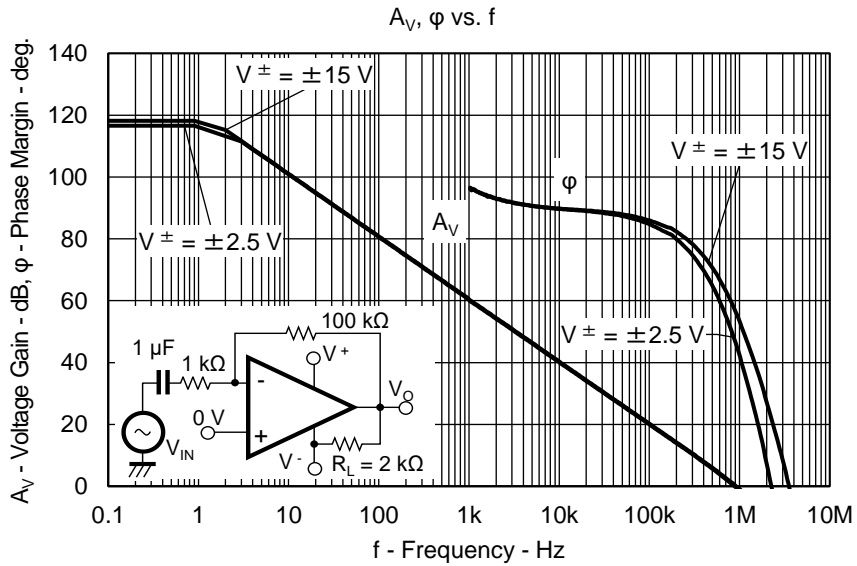
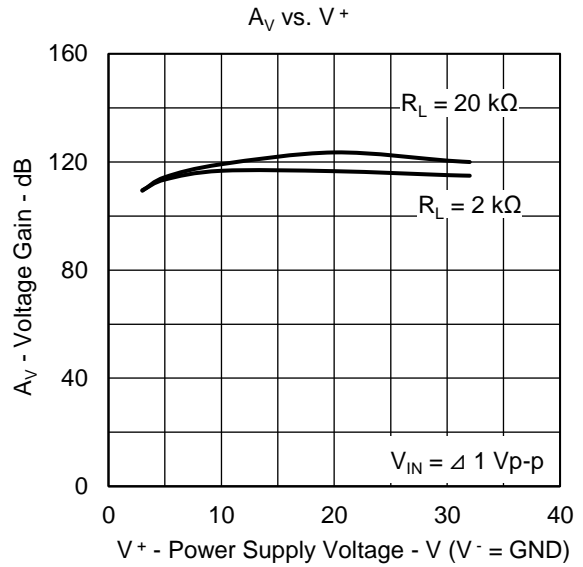
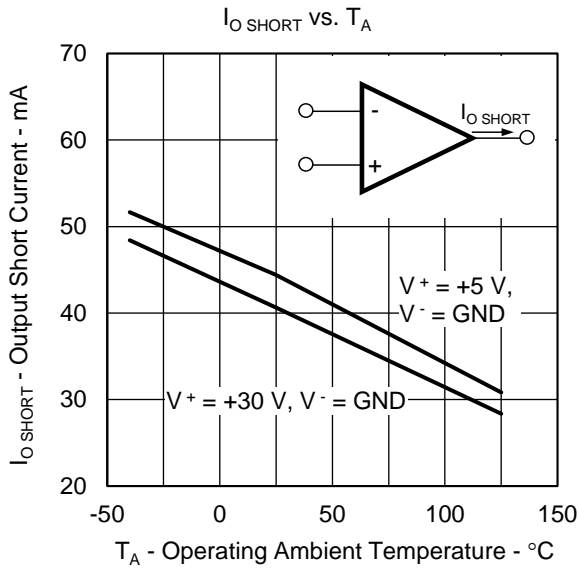

PULSE RESPONSE

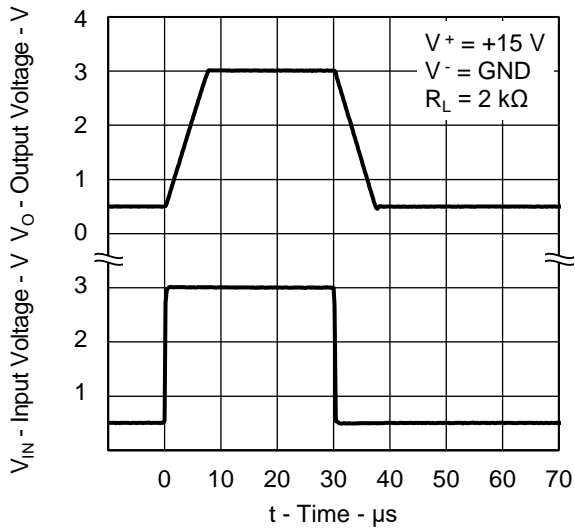

SR vs. T_A

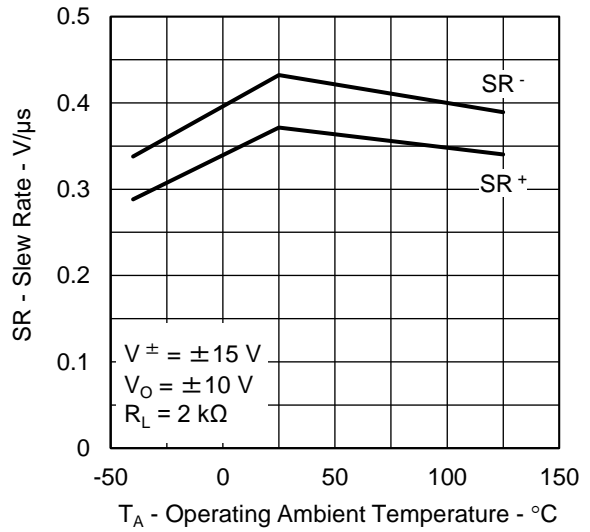

V_O vs. $I_{O\text{ SINK}}$

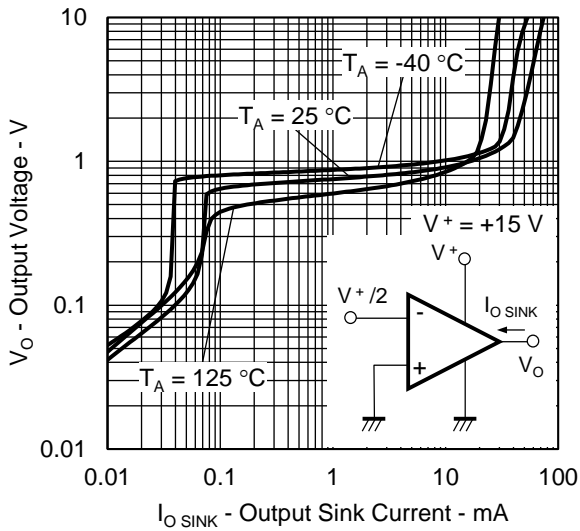

ΔV_O vs. $I_{O\text{ SOURCE}}$

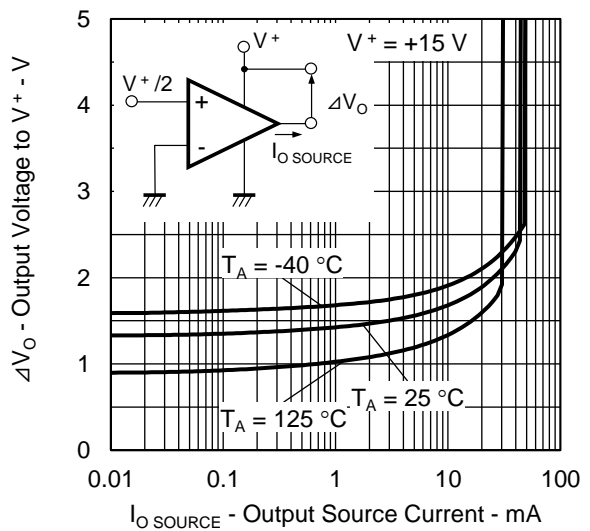

PACKAGE DRAWINGS

8-PIN PLASTIC SOP

JEITA Package code	RENESAS code	MASS (TYP.) [g]
P-LSOP8-4.4x5.2-1.27	PLSP0008DE-A	0.09[g]

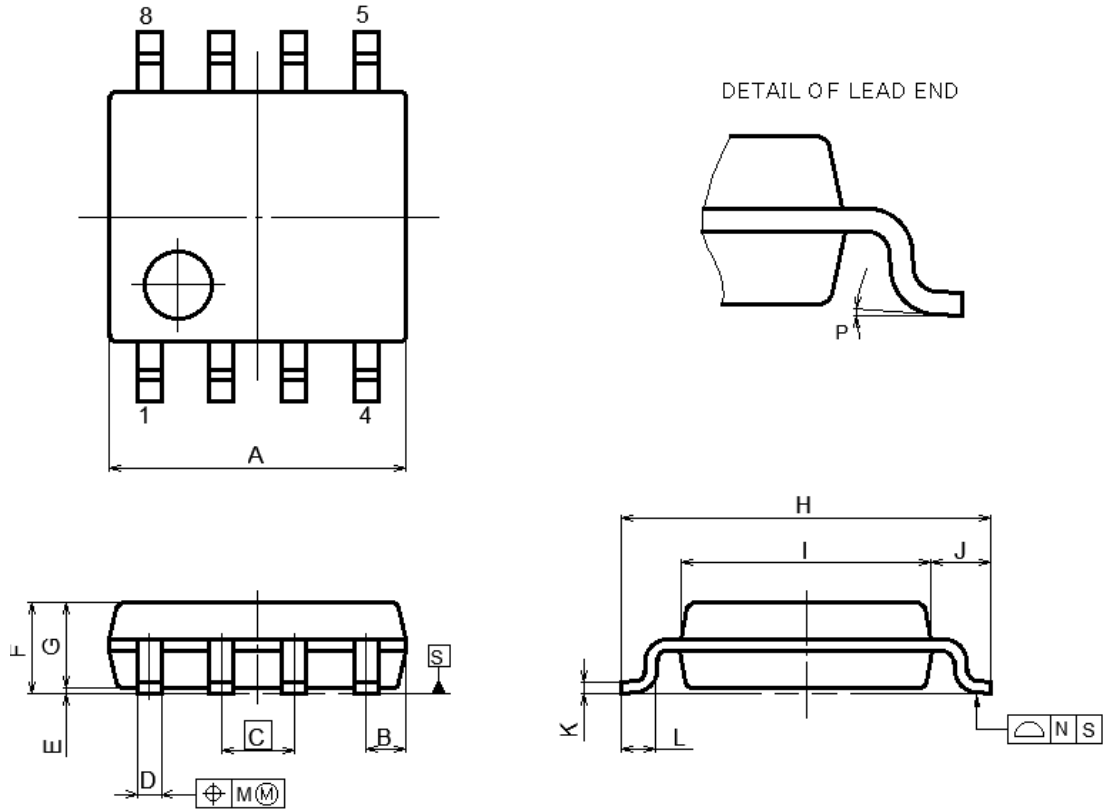

NOTE
 EACH LEAD CENTERLINE IS LOCATED WITHIN 0.12 MM OF
 ITS TRUE POSITION(T.P.) AT MAXIMUM MATERIAL CONDITION.

(UNIT:mm)

ITEM	DIMENSIONS
A	5.2±0.17
B	0.78MAX
C	1.27(T.P)
D	0.40±0.05
E	0.1±0.1
F	1.59±0.21
G	1.49
H	6.5±0.3
I	4.4±0.1
J	1.05±0.15
K	0.2±0.07
L	0.6±0.20
M	0.1MAX
N	0.1MAX
P	4°±4°

8-PIN PLASTIC TSSOP

JEITA Package code	RENESAS code	Previous code	MASS(TYP.) [g]
P-TSSOP8-0225-0.65	PTSP0008JD-A	P8GR-65-9LG	—

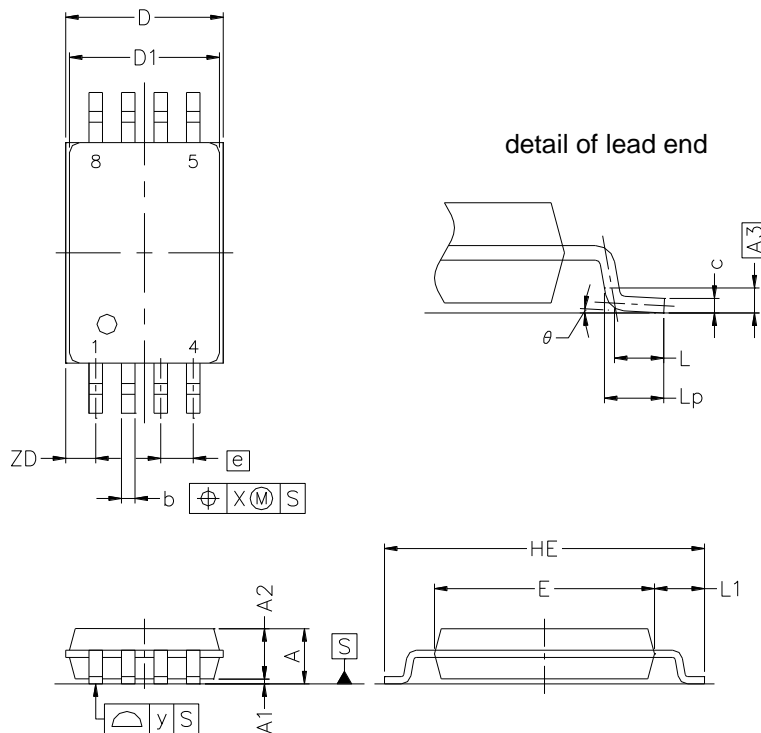

(Unit : mm)

NOTE

Each lead centerline is located within 0.10 mm of its true position at maximum material condition.

ITEM	MILLIMETERS
D	3.15 ±0.15
D1	3.00 ±0.10
E	4.40 ±0.10
HE	6.40 ±0.20
A	1.20 MAX.
A1	0.10 ±0.05
A2	1.00 ±0.05
A3	0.25
b	0.24 ^{+0.06} _{-0.05}
c	0.145 ±0.055
L	0.5
Lp	0.60 ±0.15
L1	1.00 ±0.20
θ	3° ^{+5°} _{-3°}
e	0.65
x	0.10
y	0.10
ZD	0.60

8-PIN PLASTIC MSOP

JEITA Package Code	RENESAS Code	MASS (TYP.) [g]
P-VSSOP8-2.75x2.8-0.65	PVSP0008JA-A	0.02[g]

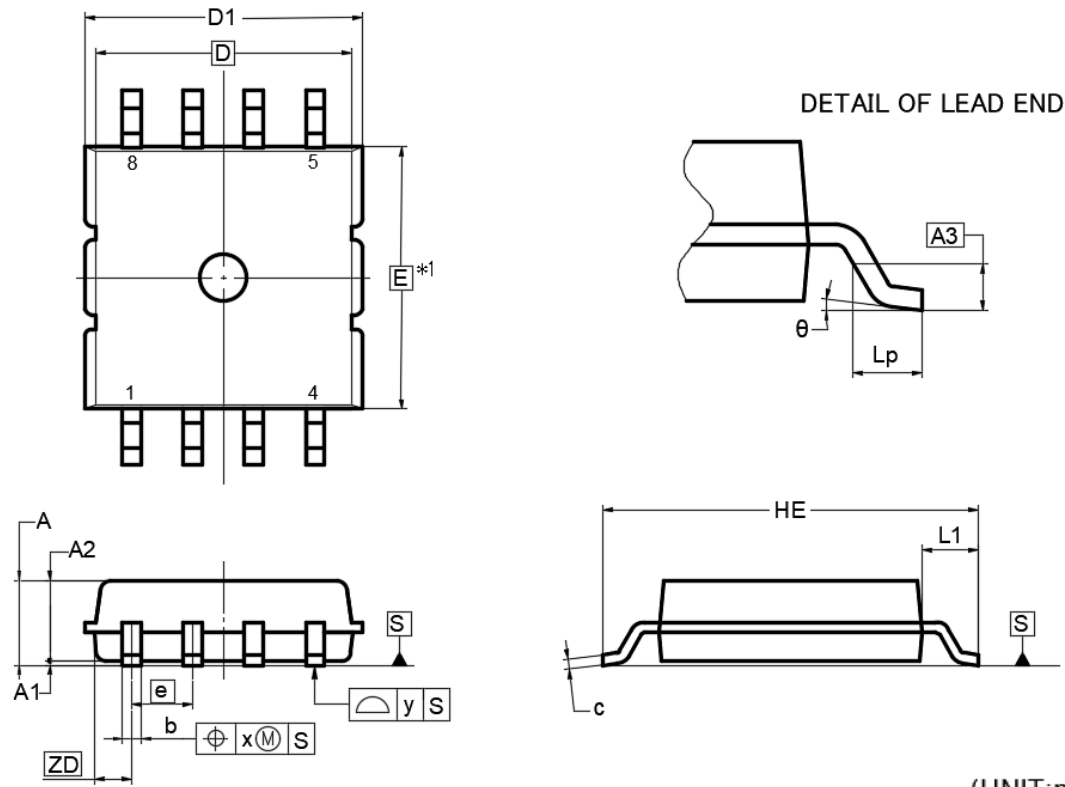

(UNIT:mm)

ITEM	DIMENSIONS
D	2.75
D1	2.95±0.20
E	2.80
HE	4.00±0.30
e	0.65
b	0.20 ^{+0.10} _{-0.05}
A	1.00MAX
A1	0.05±0.05
A2	0.85±0.10
A3	0.25
L1	0.60±0.20
c	0.13 ^{+0.10} _{-0.05}
Lp	0.37±0.12
x	0.10
y	0.10
θ	7±7°
ZD	0.50

NOTE)

- 1.DIMENSIONS"*1"
DO NOT INCLUDE MOLD FLASH.
- 2.EACH LEAD CENTERLINE IS LOCATED WITHIN 0.10 MM OF
ITS TRUE POSITION AT MAXIMUM MATERIAL CONDITION.

PRECAUTIONS FOR USE

○The process of unused circuits

If there is an unused circuit, the following connection is recommended.

Process example of unused circuits

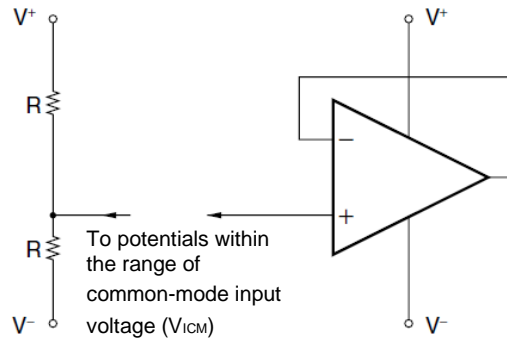

Remark A midpoint potential of V^+ and V^- is applied to this example.

○Ratings of input/output pin voltage

When the voltage of input/output pin exceeds the absolute maximum rating, it may cause degradation of characteristics or damages, by a conduction of a parasitic diode within an IC. In addition, when the input pin may be lower than V^- , or the output pin may exceed the power supply voltage, it is recommended to make a clamp circuit by a diode whose forward voltage is low (e.g.: Schottky diode) for protection.

○Range of common-mode input voltage

When the supply voltage does not meet the condition of electrical characteristics, the range of common-mode input voltage is as follows.

$$V_{ICM} \text{ (TYP.)}: V^- \text{ to } V^+ - 1.5 \text{ (V)} \text{ (} T_A = 25^\circ\text{C)}.$$

During designing, do include some tolerance by considering temperature characteristics and etc.

○The maximum output voltage

The range of the TYP. value of the maximum output voltage when the supply voltage does not meet the condition of electrical characteristics is as follows:

$$V_{Om+} \text{ (TYP.)}: V^+ - 1.6 \text{ [V]} \text{ (} T_A = 25^\circ\text{C)},$$

$$V_{Om-} \text{ (TYP.) (} I_{o \text{ SINK}} \leq 50 \mu\text{A)}: \text{Approx. } V^- \text{ (V)} \text{ (} T_A = 25^\circ\text{C)}$$

During designing, consider variations in characteristics and temperature characteristics for use with allowance. In addition, also note that the output voltage range ($V_{Om+} - V_{Om-}$) becomes narrow when an output current increases.

○Operation of output

This IC consist an output level of a class C push-pull. Therefore, when a load resistance is connected to the midpoint potential of V^+ , V^- , a crossover distortion occurs at the transition state of output current flow direction (source, sink).

○Handling of ICs

When stress is added to ICs due to warpage or bending of a board, the characteristic fluctuates due to piezoelectric effect. Therefore, pay attention to warpage or bending of a board.

Notice

1. Descriptions of circuits, software and other related information in this document are provided only to illustrate the operation of semiconductor products and application examples. You are fully responsible for the incorporation or any other use of the circuits, software, and information in the design of your product or system. Renesas Electronics disclaims any and all liability for any losses and damages incurred by you or third parties arising from the use of these circuits, software, or information.
2. Renesas Electronics hereby expressly disclaims any warranties against and liability for infringement or any other claims involving patents, copyrights, or other intellectual property rights of third parties, by or arising from the use of Renesas Electronics products or technical information described in this document, including but not limited to, the product data, drawings, charts, programs, algorithms, and application examples.
3. No license, express, implied or otherwise, is granted hereby under any patents, copyrights or other intellectual property rights of Renesas Electronics or others.
4. You shall be responsible for determining what licenses are required from any third parties, and obtaining such licenses for the lawful import, export, manufacture, sales, utilization, distribution or other disposal of any products incorporating Renesas Electronics products, if required.
5. You shall not alter, modify, copy, or reverse engineer any Renesas Electronics product, whether in whole or in part. Renesas Electronics disclaims any and all liability for any losses or damages incurred by you or third parties arising from such alteration, modification, copying or reverse engineering.
6. Renesas Electronics products are classified according to the following two quality grades: "Standard" and "High Quality". The intended applications for each Renesas Electronics product depends on the product's quality grade, as indicated below.
 - "Standard": Computers; office equipment; communications equipment; test and measurement equipment; audio and visual equipment; home electronic appliances; machine tools; personal electronic equipment; industrial robots; etc.
 - "High Quality": Transportation equipment (automobiles, trains, ships, etc.); traffic control (traffic lights); large-scale communication equipment; key financial terminal systems; safety control equipment; etc.
- Unless expressly designated as a high reliability product or a product for harsh environments in a Renesas Electronics data sheet or other Renesas Electronics document, Renesas Electronics products are not intended or authorized for use in products or systems that may pose a direct threat to human life or bodily injury (artificial life support devices or systems; surgical implantations; etc.), or may cause serious property damage (space system; undersea repeaters; nuclear power control systems; aircraft control systems; key plant systems; military equipment; etc.). Renesas Electronics disclaims any and all liability for any damages or losses incurred by you or any third parties arising from the use of any Renesas Electronics product that is inconsistent with any Renesas Electronics data sheet, user's manual or other Renesas Electronics document.
7. No semiconductor product is absolutely secure. Notwithstanding any security measures or features that may be implemented in Renesas Electronics hardware or software products, Renesas Electronics shall have absolutely no liability arising out of any vulnerability or security breach, including but not limited to any unauthorized access to or use of a Renesas Electronics product or a system that uses a Renesas Electronics product. RENESAS ELECTRONICS DOES NOT WARRANT OR GUARANTEE THAT RENESAS ELECTRONICS PRODUCTS, OR ANY SYSTEMS CREATED USING RENESAS ELECTRONICS PRODUCTS WILL BE INVULNERABLE OR FREE FROM CORRUPTION, ATTACK, VIRUSES, INTERFERENCE, HACKING, DATA LOSS OR THEFT, OR OTHER SECURITY INTRUSION ("Vulnerability Issues"). RENESAS ELECTRONICS DISCLAIMS ANY AND ALL RESPONSIBILITY OR LIABILITY ARISING FROM OR RELATED TO ANY VULNERABILITY ISSUES. FURTHERMORE, TO THE EXTENT PERMITTED BY APPLICABLE LAW, RENESAS ELECTRONICS DISCLAIMS ANY AND ALL WARRANTIES, EXPRESS OR IMPLIED, WITH RESPECT TO THIS DOCUMENT AND ANY RELATED OR ACCOMPANYING SOFTWARE OR HARDWARE, INCLUDING BUT NOT LIMITED TO THE IMPLIED WARRANTIES OF MERCHANTABILITY, OR FITNESS FOR A PARTICULAR PURPOSE.
8. When using Renesas Electronics products, refer to the latest product information (data sheets, user's manuals, application notes, "General Notes for Handling and Using Semiconductor Devices" in the reliability handbook, etc.), and ensure that usage conditions are within the ranges specified by Renesas Electronics with respect to maximum ratings, operating power supply voltage range, heat dissipation characteristics, installation, etc. Renesas Electronics disclaims any and all liability for any malfunctions, failure or accident arising out of the use of Renesas Electronics products outside of such specified ranges.
9. Although Renesas Electronics endeavors to improve the quality and reliability of Renesas Electronics products, semiconductor products have specific characteristics, such as the occurrence of failure at a certain rate and malfunctions under certain use conditions. Unless designated as a high reliability product or a product for harsh environments in a Renesas Electronics data sheet or other Renesas Electronics document, Renesas Electronics products are not subject to radiation resistance design. You are responsible for implementing safety measures to guard against the possibility of bodily injury, injury or damage caused by fire, and/or danger to the public in the event of a failure or malfunction of Renesas Electronics products, such as safety design for hardware and software, including but not limited to redundancy, fire control and malfunction prevention, appropriate treatment for aging degradation or any other appropriate measures. Because the evaluation of microcomputer software alone is very difficult and impractical, you are responsible for evaluating the safety of the final products or systems manufactured by you.
10. Please contact a Renesas Electronics sales office for details as to environmental matters such as the environmental compatibility of each Renesas Electronics product. You are responsible for carefully and sufficiently investigating applicable laws and regulations that regulate the inclusion or use of controlled substances, including without limitation, the EU RoHS Directive, and using Renesas Electronics products in compliance with all these applicable laws and regulations. Renesas Electronics disclaims any and all liability for damages or losses occurring as a result of your noncompliance with applicable laws and regulations.
11. Renesas Electronics products and technologies shall not be used for or incorporated into any products or systems whose manufacture, use, or sale is prohibited under any applicable domestic or foreign laws or regulations. You shall comply with any applicable export control laws and regulations promulgated and administered by the governments of any countries asserting jurisdiction over the parties or transactions.
12. It is the responsibility of the buyer or distributor of Renesas Electronics products, or any other party who distributes, disposes of, or otherwise sells or transfers the product to a third party, to notify such third party in advance of the contents and conditions set forth in this document.
13. This document shall not be reprinted, reproduced or duplicated in any form, in whole or in part, without prior written consent of Renesas Electronics.
14. Please contact a Renesas Electronics sales office if you have any questions regarding the information contained in this document or Renesas Electronics products.

(Note1) "Renesas Electronics" as used in this document means Renesas Electronics Corporation and also includes its directly or indirectly controlled subsidiaries.

(Note2) "Renesas Electronics product(s)" means any product developed or manufactured by or for Renesas Electronics.

(Rev.5.0-1 October 2020)

Corporate Headquarters

TOYOSU FORESIA, 3-2-24 Toyosu,
Koto-ku, Tokyo 135-0061, Japan
www.renesas.com

Trademarks

Renesas and the Renesas logo are trademarks of Renesas Electronics Corporation. All trademarks and registered trademarks are the property of their respective owners.

Contact information

For further information on a product, technology, the most up-to-date version of a document, or your nearest sales office, please visit:
www.renesas.com/contact/.