

General Description

The SLG59M1515V is a 20 mΩ 2.0 A single-channel load switch with configurable slew rate control. The device can enable fast power rail turn on with big cap loading. Internal circuit limits max inrush current to prevent device damage. The product is packaged in an ultra-small 1.0x1.6mm package.

Features

- 1.0 x 1.6 x 0.55 mm STDFN 8L package (2 fused pins for drain and 2 fused pins for source)
- Logic level ON pin capable of supporting 0.85 V CMOS Logic
- Discharged Load when off
- Fast Turn On time
 - 25 μs, Tune Cap = 0.1 nF, C_{LOAD} = 1 μF @ 100 mA
 - 95 μs, Tune Cap = 0.5 nF, C_{LOAD} = 10 μF @ 2.5 A
- Low RDS_{ON} while supporting 2.0 A
 - 20 mΩ, V_{DD} = 5 V, V_D = 1 V
 - 27.5 mΩ, V_{DD} = 3.3 V, V_D = 1 V
- Pb-Free / Halogen-Free / RoHS compliant
- Operating Temperature: -40 °C to 85°C
- Operating Voltage: 2.5 V to 5.5 V
- Power Rail Switching V_D = 0.85 V to V_D = V_{DD} - 1.5 V

Pin Configuration

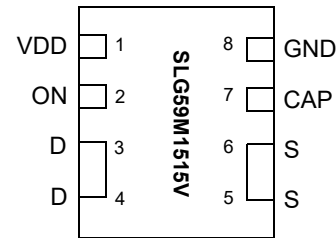

8-pin STDFN
(Top View)

Applications

- Fast Turn On/Off power rail switching with big Cap loading
- Frequent wake & sleep power cycle
- Mobile devices and portable devices

Block Diagram

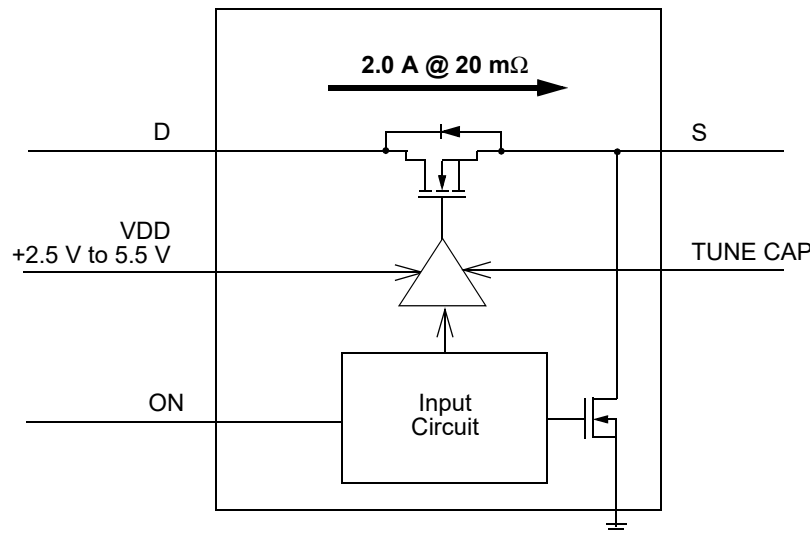

Pin Description

Pin #	Pin Name	Type	Pin Description
1	VDD	PWR	VDD power for load switch control (2.5 V to 5.5 V)
2	ON	Input	Turns MOSFET ON (4 M Ω pull down resistor) CMOS input with VIL < 0.3 V, VIH > 0.85 V
3	D	MOSFET	Drain of Power MOSFET (fused with pin 4)
4	D	MOSFET	Drain of Power MOSFET (fused with pin 3)
5	S	MOSFET	Source of Power MOSFET (fused with pin 6)
6	S	MOSFET	Source of Power MOSFET (fused with pin 5)
7	CAP	CAP	Tuning Cap
8	GND	GND	Ground

Ordering Information

Part Number	Type	Production Flow
SLG59M1515V	STDFN 8L	Industrial, -40 °C to 85 °C
SLG59M1515VTR	STDFN 8L (Tape and Reel)	Industrial, -40 °C to 85 °C

Absolute Maximum Ratings

Parameter	Description	Conditions	Min.	Typ.	Max.	Unit
V_{DD}	Power Supply		--	--	7	V
T_S	Storage Temperature		-65	--	150	°C
ESD_{HBM}	ESD Protection	Human Body Model	2000	--	--	V
W_{DIS}	Package Power Dissipation		--	--	0.4	W
$MOSFET\ I_{DS_{PK}}$	Peak Current from Drain to Source	For no more than 20 μs with 1% duty cycle	--	--	25.0	A
		For no more than 50 μs with 1% duty cycle	--	--	12.5	A
		For no more than 1 ms with 1% duty cycle	--	--	3.5	A

Note: Stresses greater than those listed under "Absolute Maximum Ratings" may cause permanent damage to the device. This is a stress rating only and functional operation of the device at these or any other conditions above those indicated in the operational sections of this specification is not implied. Exposure to absolute maximum rating conditions for extended periods may affect reliability.

Electrical Characteristics

$T_A = -40\text{ °C to }85\text{ °C}$ (unless otherwise stated)

Parameter	Description	Conditions	Min.	Typ.	Max.	Unit
V_{DD}	Power Supply Voltage	-40 °C to 85 °C	2.5	--	5.5	V
I_{DD}	Power Supply Current (PIN 1)	when OFF	--	--	1	μA
		when ON, No load	--	--	10	μA
$R_{DS_{ON}}$	Static Drain to Source ON Resistance, $T_A = 25\text{ °C}$	$V_{DD} = 5\text{ V}, V_D = 1.05\text{ V}, V_{DD} - V_D = 4.0\text{ V}, R_L = 0.5\ \Omega$	--	20	22	m Ω
		$V_{DD} = 3.3\text{ V}, V_D = 1.05\text{ V}, V_{DD} - V_D = 2.3\text{ V}, R_L = 0.5\ \Omega$	--	27.5	29	m Ω
	Static Drain to Source ON Resistance, $T_A = 70\text{ °C}$	$V_{DD} = 5\text{ V}, V_D = 1.05\text{ V}, V_{DD} - V_D = 4.0\text{ V}, R_L = 0.5\ \Omega$	--	23.5	25	m Ω
		$V_{DD} = 3.3\text{ V}, V_D = 1.05\text{ V}, V_{DD} - V_D = 2.3\text{ V}, R_L = 0.5\ \Omega$	--	31	33	m Ω
	Static Drain to Source ON Resistance, $T_A = 85\text{ °C}$	$V_{DD} = 5\text{ V}, V_D = 1.05\text{ V}, V_{DD} - V_D = 4.0\text{ V}, R_L = 0.5\ \Omega$	--	24.5	26	m Ω
		$V_{DD} = 3.3\text{ V}, V_D = 1.05\text{ V}, V_{DD} - V_D = 2.3\text{ V}, R_L = 0.5\ \Omega$	--	33	35	m Ω
I_{DS}	Operating Current	$V_D = 0.85\text{ V to }3.3\text{ V}$	--	--	2.0	A
V_D	Drain Voltage		0.85	--	$V_{DD} - 1.5$	V
T_{ON_Delay}	ON Delay Time	50% ON to 10% V_S , Internal Logic Delay, $V_{DD} = 5\text{ V}, V_D = 1.05\text{ V}$, Tune Cap = 0.1 nF	--	12	15	μs
		50% ON to 10% V_S , Internal Logic Delay, $V_{DD} = 5\text{ V}, V_D = 1.05\text{ V}$, Tune Cap = 0.5 nF	--	32	35	μs

T_A = -40 °C to 85 °C (unless otherwise stated)

Parameter	Description	Conditions	Min.	Typ.	Max.	Unit
T _{Total_ON}	Total Turn On Time	50% ON to 90% V _S	Configurable			
		50% ON to 90% V _S , V _{DD} = 5 V, V _D = 1.0 V, C _L = 1 μF, Current Load = 50 mA, Tune Cap = 0.1 nF	--	32	39	μs
		50% ON to 90% V _S , V _{DD} = 5 V, V _D = 1.0 V, C _L = 1 μF, Current Load = 100 mA, Tune Cap = 0.1 nF	--	32	39	μs
		50% ON to 90% V _S , V _{DD} = 5 V, V _D = 1.0 V, C _L = 4.7 μF, Current Load = 2.5 A, Tune Cap = 0.5 nF	--	102	123	μs
		50% ON to 90% V _S , V _{DD} = 5 V, V _D = 1.0 V, C _L = 10 μF, Current Load = 2.5 A, Tune Cap = 0.5 nF	--	102	123	μs
T _{SLEWRATE}	Slew Rate	10% V _S to 90% V _S	Configurable			
		10% V _S to 90% V _S , V _{DD} = 5 V, V _D = 1.0 V, C _L = 1 μF, Current Load = 50 mA, Tune Cap = 0.1 nF	--	65	78	V/ms
		10% V _S to 90% V _S , V _{DD} = 5 V, V _D = 1.0 V, C _L = 1 μF, Current Load = 100 mA, Tune Cap = 0.1 nF	--	65	78	V/ms
		10% V _S to 90% V _S , V _{DD} = 5 V, V _D = 1.0 V, C _L = 4.7 μF, Current Load = 2.5 A, Tune Cap = 0.5 nF	--	13	16	V/ms
		10% V _S to 90% V _S , V _{DD} = 5 V, V _D = 1.0 V, C _L = 10 μF, Current Load = 2.5 A, Tune Cap = 0.5 nF	--	13.5	16.5	V/ms
CAP _{SOURCE}	Source Cap	Source to GND	--	--	10	μF
R _{DIS}	Discharge Resistance		100	150	300	Ω
ON_V _{IH}	High Input Voltage on ON pin		0.85	--	V _{DD}	V
ON_V _{IL}	Low Input Voltage on ON pin		-0.3	0	0.3	V
T _{OFF_Delay}	OFF Delay Time	50% ON to V _S Fall, C _L = 10 μF, R _L = 20 Ω, V _{DD} = 5 V, V _D = 1.0 V, No Tune CAP	--	120	150	μs
THERM_OFF	Thermal Protection Shutoff	Programmable, automatic shutoff temperature	--	125	--	°C
THERM_OFF_ACC	Thermal Sensor Accuracy		--	--	±20	%
THERM_DT	Thermal Disable Time	Thermal sensor disable for the ON rising edge to 100 μs. Prevent therm shutdown from inrush current	--	--	100	μs

Tune Cap vs Slew Rate

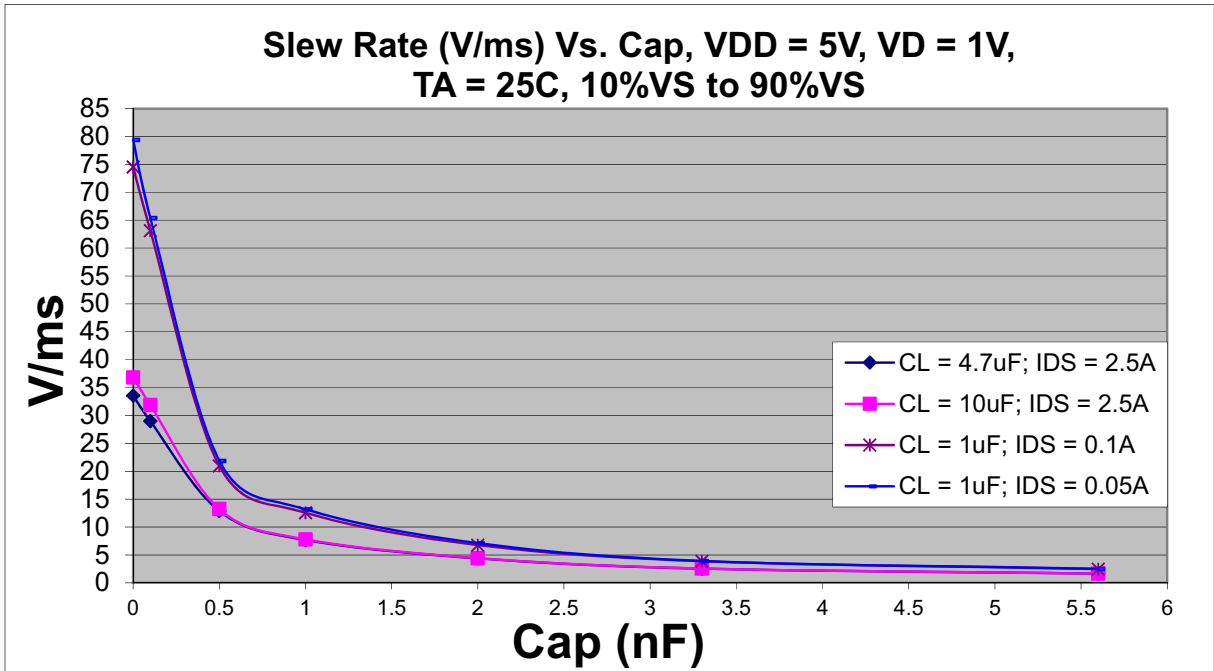

Tune Cap vs Ttotal_on

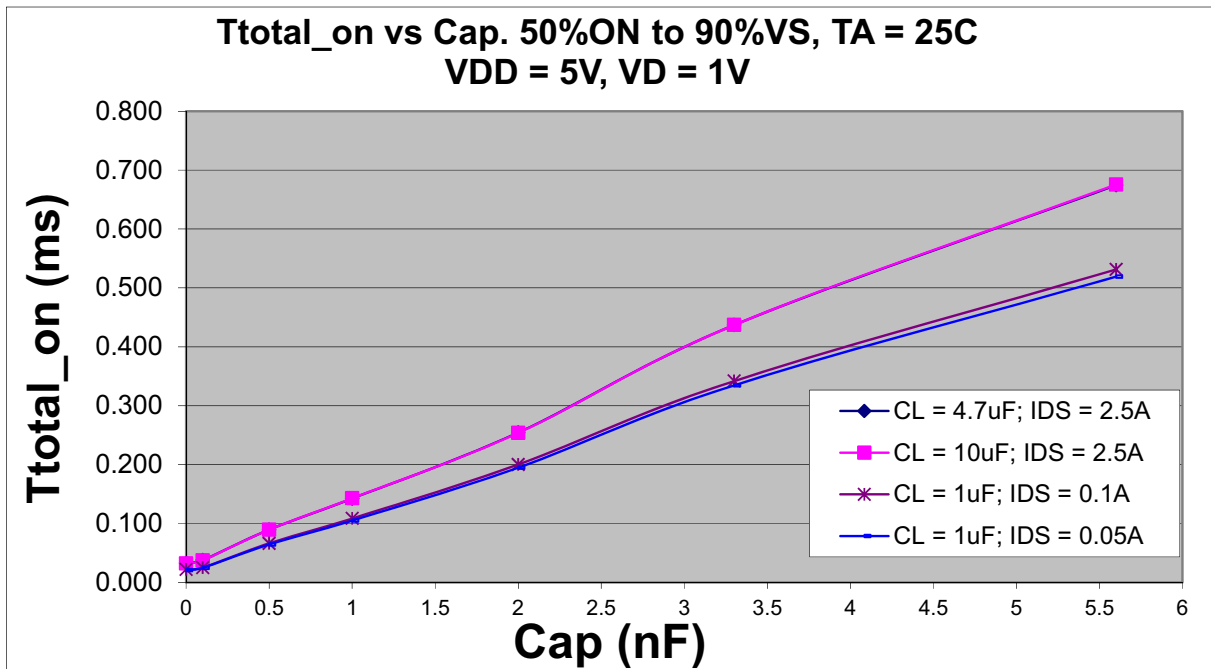

T_{Total_ON} , T_{ON_Delay} and Slew Rate Measurement (TBD)

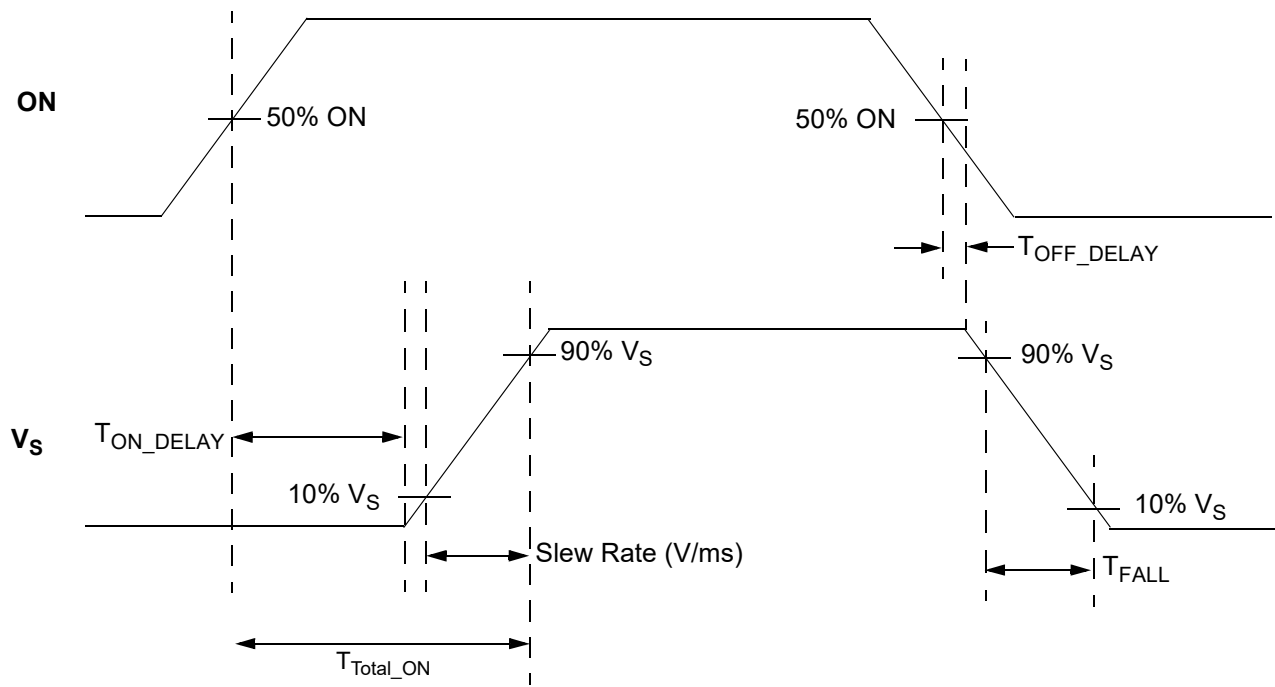

Package Top Marking System Definition

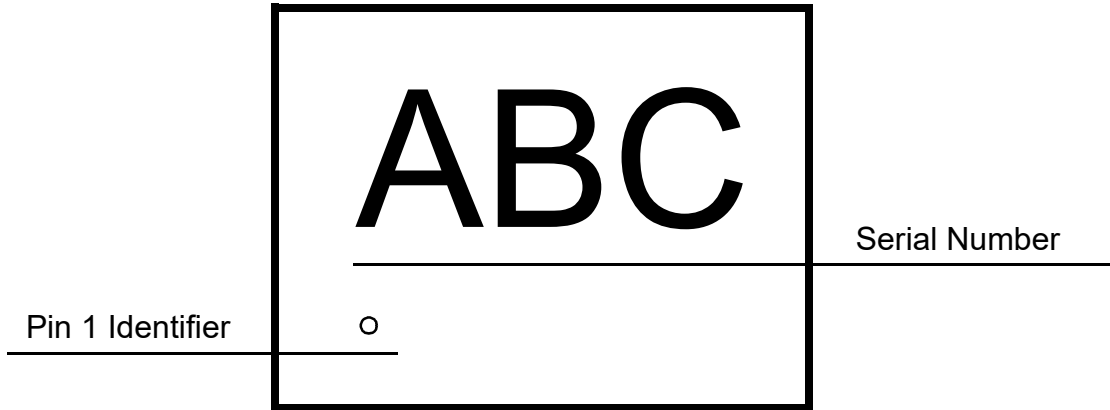

Package Drawing and Dimensions

8 Lead STDFN Package 1.0 x 1.6 mm (Fused Lead)

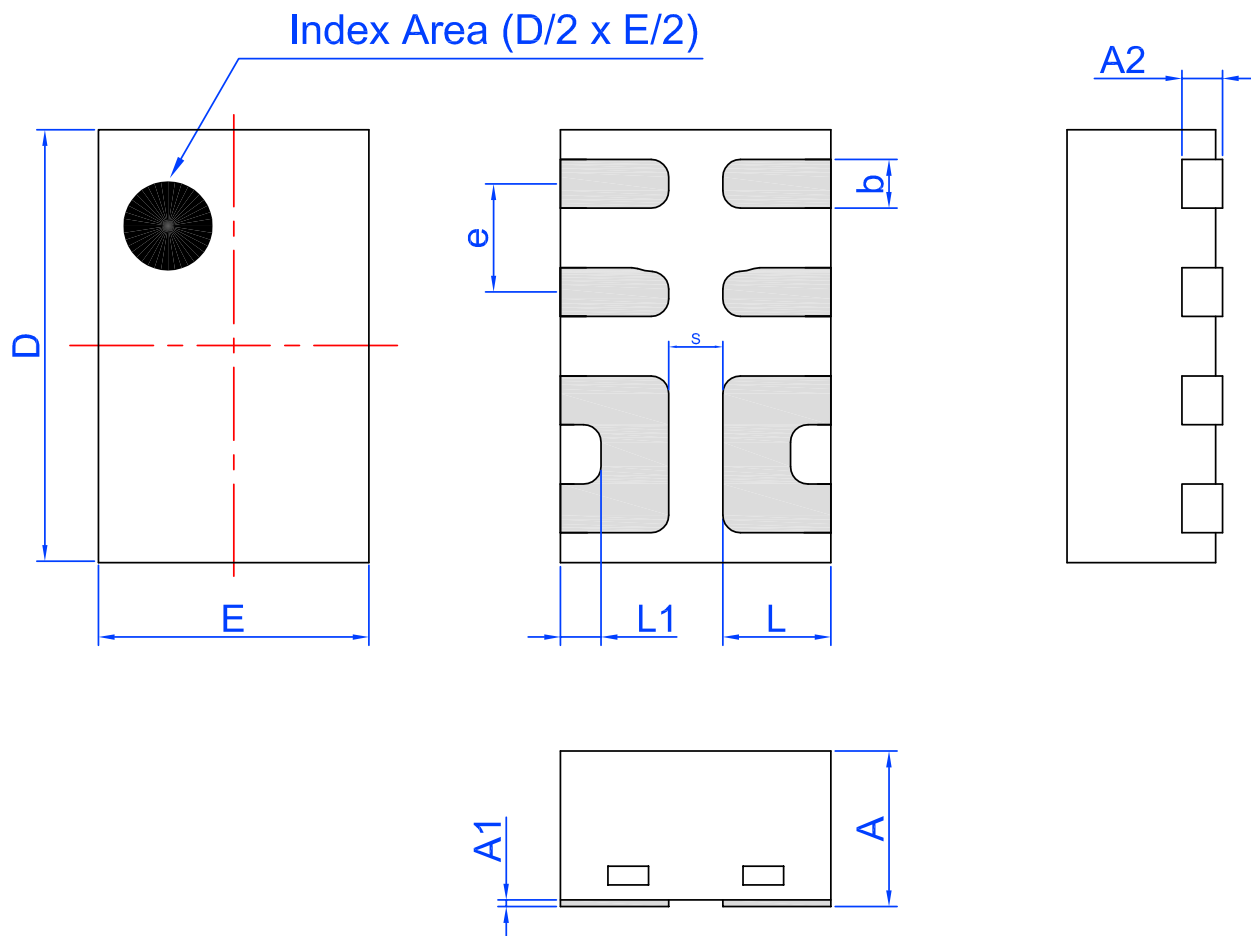

Unit: mm

Symbol	Min	Nom.	Max	Symbol	Min	Nom.	Max
A	0.50	0.55	0.60	D	1.55	1.60	1.65
A1	0.005	-	0.060	E	0.95	1.00	1.05
A2	0.10	0.15	0.20	L	0.35	0.40	0.45
b	0.13	0.18	0.23	L1	0.10	0.15	0.20
e	0.40 BSC			S	0.2 REF		

Tape and Reel Specifications

Package Type	# of Pins	Nominal Package Size [mm]	Max Units		Reel & Hub Size [mm]	Leader (min)		Trailer (min)		Tape Width [mm]	Part Pitch [mm]
			per Reel	per Box		Pockets	Length [mm]	Pockets	Length [mm]		
STDFN 8L 1x1.6mm 0.4P FC Green	8	1.0 x 1.6 x 0.55	3,000	3,000	178 / 60	100	400	100	400	8	4

Carrier Tape Drawing and Dimensions

Package Type	Pocket BTM Length	Pocket BTM Width	Pocket Depth	Index Hole Pitch	Pocket Pitch	Index Hole Diameter	Index Hole to Tape Edge	Index Hole to Pocket Center	Tape Width
	A0	B0	K0	P0	P1	D0	E	F	W
STDFN 8L 1x1.6mm 0.4P FC Green	1.12	1.72	0.7	4	4	1.55	1.75	3.5	8

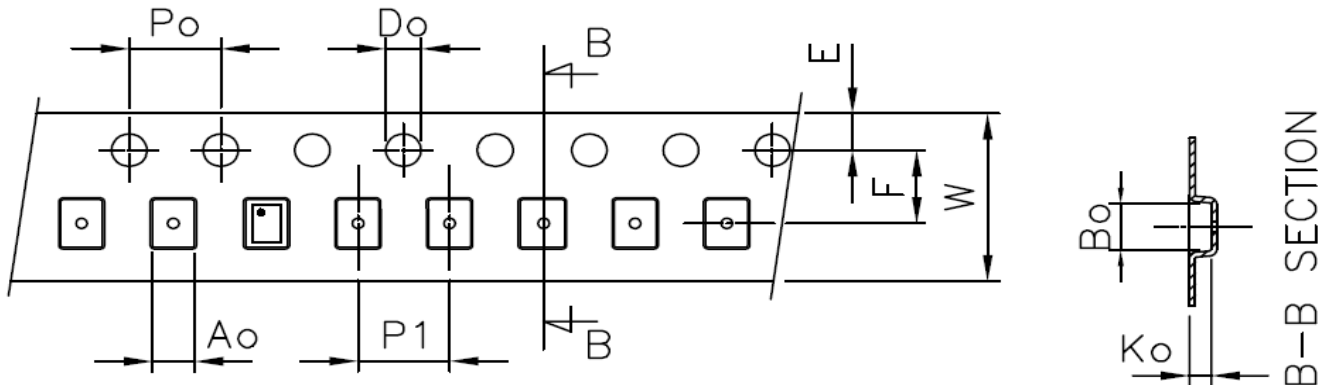

Recommended Reflow Soldering Profile

Please see IPC/JEDEC J-STD-020: latest revision for reflow profile based on package volume of 0.88 mm³ (nominal). More information can be found at www.jedec.org.

IMPORTANT NOTICE AND DISCLAIMER

RENESAS ELECTRONICS CORPORATION AND ITS SUBSIDIARIES (“RENESAS”) PROVIDES TECHNICAL SPECIFICATIONS AND RELIABILITY DATA (INCLUDING DATASHEETS), DESIGN RESOURCES (INCLUDING REFERENCE DESIGNS), APPLICATION OR OTHER DESIGN ADVICE, WEB TOOLS, SAFETY INFORMATION, AND OTHER RESOURCES “AS IS” AND WITH ALL FAULTS, AND DISCLAIMS ALL WARRANTIES, EXPRESS OR IMPLIED, INCLUDING, WITHOUT LIMITATION, ANY IMPLIED WARRANTIES OF MERCHANTABILITY, FITNESS FOR A PARTICULAR PURPOSE, OR NON-INFRINGEMENT OF THIRD-PARTY INTELLECTUAL PROPERTY RIGHTS.

These resources are intended for developers who are designing with Renesas products. You are solely responsible for (1) selecting the appropriate products for your application, (2) designing, validating, and testing your application, and (3) ensuring your application meets applicable standards, and any other safety, security, or other requirements. These resources are subject to change without notice. Renesas grants you permission to use these resources only to develop an application that uses Renesas products. Other reproduction or use of these resources is strictly prohibited. No license is granted to any other Renesas intellectual property or to any third-party intellectual property. Renesas disclaims responsibility for, and you will fully indemnify Renesas and its representatives against, any claims, damages, costs, losses, or liabilities arising from your use of these resources. Renesas' products are provided only subject to Renesas' Terms and Conditions of Sale or other applicable terms agreed to in writing. No use of any Renesas resources expands or otherwise alters any applicable warranties or warranty disclaimers for these products.

(Disclaimer Rev.1.01 Jan 2024)

Corporate Headquarters

TOYOSU FORESIA, 3-2-24 Toyosu,
Koto-ku, Tokyo 135-0061, Japan
www.renesas.com

Trademarks

Renesas and the Renesas logo are trademarks of Renesas Electronics Corporation. All trademarks and registered trademarks are the property of their respective owners.

Contact Information

For further information on a product, technology, the most up-to-date version of a document, or your nearest sales office, please visit www.renesas.com/contact-us/.