

To our customers,

---

## Old Company Name in Catalogs and Other Documents

---

On April 1<sup>st</sup>, 2010, NEC Electronics Corporation merged with Renesas Technology Corporation, and Renesas Electronics Corporation took over all the business of both companies. Therefore, although the old company name remains in this document, it is a valid Renesas Electronics document. We appreciate your understanding.

Renesas Electronics website: <http://www.renesas.com>

April 1<sup>st</sup>, 2010  
Renesas Electronics Corporation

Issued by: Renesas Electronics Corporation (<http://www.renesas.com>)

Send any inquiries to <http://www.renesas.com/inquiry>.

Not recommended  
for new design

## Notice

1. All information included in this document is current as of the date this document is issued. Such information, however, is subject to change without any prior notice. Before purchasing or using any Renesas Electronics products listed herein, please confirm the latest product information with a Renesas Electronics sales office. Also, please pay regular and careful attention to additional and different information to be disclosed by Renesas Electronics such as that disclosed through our website.
2. Renesas Electronics does not assume any liability for infringement of patents, copyrights, or other intellectual property rights of third parties by or arising from the use of Renesas Electronics products or technical information described in this document. No license, express, implied or otherwise, is granted hereby under any patents, copyrights or other intellectual property rights of Renesas Electronics or others.
3. You should not alter, modify, copy, or otherwise misappropriate any Renesas Electronics product, whether in whole or in part.
4. Descriptions of circuits, software and other related information in this document are provided only to illustrate the operation of semiconductor products and application examples. You are fully responsible for the incorporation of these circuits, software, and information in the design of your equipment. Renesas Electronics assumes no responsibility for any losses incurred by you or third parties arising from the use of these circuits, software, or information.
5. When exporting the products or technology described in this document, you should comply with the applicable export control laws and regulations and follow the procedures required by such laws and regulations. You should not use Renesas Electronics products or the technology described in this document for any purpose relating to military applications or use by the military, including but not limited to the development of weapons of mass destruction. Renesas Electronics products and technology may not be used for or incorporated into any products or systems whose manufacture, use, or sale is prohibited under any applicable domestic or foreign laws or regulations.
6. Renesas Electronics has used reasonable care in preparing the information included in this document, but Renesas Electronics does not warrant that such information is error free. Renesas Electronics assumes no liability whatsoever for any damages incurred by you resulting from errors in or omissions from the information included herein.
7. Renesas Electronics products are classified according to the following three quality grades: “Standard”, “High Quality”, and “Specific”. The recommended applications for each Renesas Electronics product depends on the product’s quality grade, as indicated below. You must check the quality grade of each Renesas Electronics product before using it in a particular application. You may not use any Renesas Electronics product for any application categorized as “Specific” without the prior written consent of Renesas Electronics. Further, you may not use any Renesas Electronics product for any application for which it is not intended without the prior written consent of Renesas Electronics. Renesas Electronics shall not be in any way liable for any damages or losses incurred by you or third parties arising from the use of any Renesas Electronics product for an application categorized as “Specific” or for which the product is not intended where you have failed to obtain the prior written consent of Renesas Electronics. The quality grade of each Renesas Electronics product is “Standard” unless otherwise expressly specified in a Renesas Electronics data sheets or data books, etc.
  - “Standard”: Computers; office equipment; communications equipment; test and measurement equipment; audio and visual equipment; home electronic appliances; machine tools; personal electronic equipment; and industrial robots.
  - “High Quality”: Transportation equipment (automobiles, trains, ships, etc.); traffic control systems; anti-disaster systems; anti-crime systems; safety equipment; and medical equipment not specifically designed for life support.
  - “Specific”: Aircraft; aerospace equipment; submersible repeaters; nuclear reactor control systems; medical equipment or systems for life support (e.g. artificial life support devices or systems), surgical implantations, or healthcare intervention (e.g. excision, etc.), and any other applications or purposes that pose a direct threat to human life.
8. You should use the Renesas Electronics products described in this document within the range specified by Renesas Electronics, especially with respect to the maximum rating, operating supply voltage range, movement power voltage range, heat radiation characteristics, installation and other product characteristics. Renesas Electronics shall have no liability for malfunctions or damages arising out of the use of Renesas Electronics products beyond such specified ranges.
9. Although Renesas Electronics endeavors to improve the quality and reliability of its products, semiconductor products have specific characteristics such as the occurrence of failure at a certain rate and malfunctions under certain use conditions. Further, Renesas Electronics products are not subject to radiation resistance design. Please be sure to implement safety measures to guard them against the possibility of physical injury, and injury or damage caused by fire in the event of the failure of a Renesas Electronics product, such as safety design for hardware and software including but not limited to redundancy, fire control and malfunction prevention, appropriate treatment for aging degradation or any other appropriate measures. Because the evaluation of microcomputer software alone is very difficult, please evaluate the safety of the final products or system manufactured by you.
10. Please contact a Renesas Electronics sales office for details as to environmental matters such as the environmental compatibility of each Renesas Electronics product. Please use Renesas Electronics products in compliance with all applicable laws and regulations that regulate the inclusion or use of controlled substances, including without limitation, the EU RoHS Directive. Renesas Electronics assumes no liability for damages or losses occurring as a result of your noncompliance with applicable laws and regulations.
11. This document may not be reproduced or duplicated, in any form, in whole or in part, without prior written consent of Renesas Electronics.
12. Please contact a Renesas Electronics sales office if you have any questions regarding the information contained in this document or Renesas Electronics products, or if you have any other inquiries.

(Note 1) “Renesas Electronics” as used in this document means Renesas Electronics Corporation and also includes its majority-owned subsidiaries.

(Note 2) “Renesas Electronics product(s)” means any product developed or manufactured by or for Renesas Electronics.

MOS INTEGRATED CIRCUIT  
Bipolar Analog Integrated Circuit  
 **$\mu$ PC1555**

TIMER CIRCUIT

The  $\mu$ PC1555 is a powerful integrated circuit. Adding a few external parts to it can turn it into various types of timing signal generators, such as monostable and astable multivibrators. It has trigger, threshold, and control pins. Inputting a signal to the reset pin can stop the circuit operation easily. In addition, the output can sink current as high as 200 mA (maximum). So, it can be used to drive relays and lamps.

TYPICAL CHARACTERISTICS

- Supply voltage : 4.5 to 16 V
- Circuit current ( $V_{CC} = 5\text{ V}$ ) : 3 mA
- Output current capacity : 200 mA
- Temperature stability : 0.005%/ $^{\circ}\text{C}$
- Rising and falling time : 100 ns

FEATURES

- Monostable and astable oscillation
- Interfacing directly with TTL-level signals
- Variable duty cycle

ORDERING INFORMATION

Part number	Package
$\mu$ PC1555C	8-pin plastic DIP (300 mil)
$\mu$ PC1555G2	8-pin plastic SOP (225 mil)

PIN CONFIGURATION (TOP VIEW)

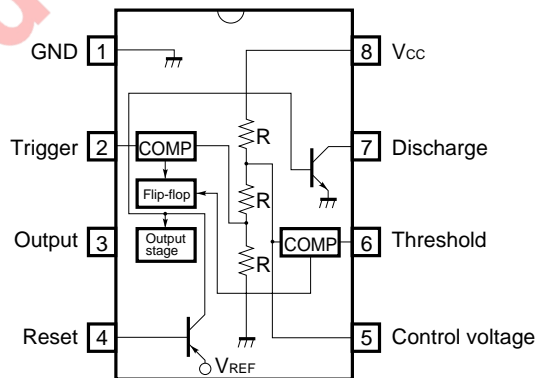

EQUIVALENT CIRCUIT

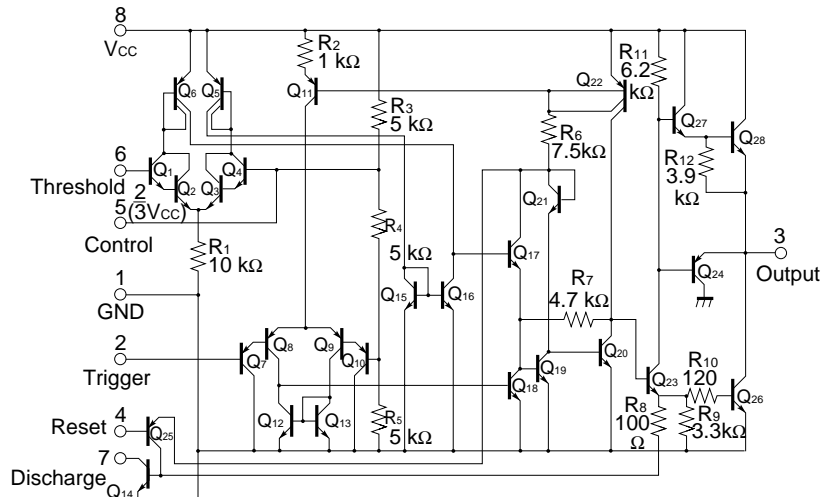

**ABSOLUTE MAXIMUM RATINGS** (T<sub>A</sub> = 25°C)

Parameter	Symbol	Rated value		Unit
		μPC1555C	μPC1555G	
Supply voltage	V <sub>CC</sub>	-0.3 to +18	-0.3 to +18	V
Input voltage (trigger, threshold, reset, control)	V <sub>IN</sub>	-0.3 to V <sub>CC</sub> + 0.3	-0.3 to V <sub>CC</sub> + 0.3	V
Applicable output voltage <sup>Note 4</sup> (output and discharge)	V <sub>O</sub>	-0.3 to V <sub>CC</sub> + 0.3	-0.3 to V <sub>CC</sub> + 0.3	V
Output current	I <sub>O</sub>	200 <sup>Note 1</sup>	200 <sup>Note 1</sup>	mA
Power dissipation	P <sub>T</sub>	600 <sup>Note 2</sup>	440 <sup>Note 3</sup>	mW
Operating temperature	T <sub>A</sub>	-20 to +80	-20 to +80	°C
Storage temperature	T <sub>stg</sub>	-55 to +125	-55 to +125	°C

**Notes 1.** Be sure to use the product within the Power dissipation.

**2.** For T<sub>A</sub> ≥ 25°C, the total loss is derated at T<sub>J</sub> MAX = 125°C and -6 mW/°C.

(See the P<sub>T</sub>-T<sub>A</sub> characteristic curve.)

**3.** For T<sub>A</sub> ≥ 25°C, the total loss is derated at T<sub>J</sub> MAX = 125°C and -4.4 mW/°C.

(See the P<sub>T</sub>-T<sub>A</sub> characteristic curve.)

**4.** This is an external voltage that can be applied to the output pin without deteriorating the quality of the product or causing damage to the product.

Be sure to use the product within the rated value under any conditions where coils are inserted or power is turned on or off. The output voltage that can be obtained during normal operation is within the output saturation voltage range.

**RECOMMENDED OPERATING CONDITIONS** (T<sub>A</sub> = 25°C)

Parameter	Symbol	Conditions	MIN.	MAX.	Unit
Supply voltage	V <sub>CC</sub>		4.5	16	V
Oscillation frequency	f	V <sub>CC</sub> = 5 to 15 V	0.1	100 k	Hz
Output pulse width	t <sub>w</sub> (OUT)	V <sub>CC</sub> = 5 to 15 V	10 μ	10	Sec
Input voltage (trigger, threshold)	V <sub>IN</sub>		0	V <sub>CC</sub>	V
Input voltage <sup>Note 5</sup> (control)	V <sub>IN</sub>		3.0	V <sub>CC</sub> • 1.5	V
Reset voltage (high level)	V <sub>reset H</sub>	V <sub>CC</sub> = 5 to 15 V	1.0	V <sub>CC</sub>	V
Reset voltage (low level)	V <sub>reset L</sub>	V <sub>CC</sub> = 5 to 15 V	0	0.4	V

**Note 5.** This parameter defines the voltage that can be applied when a PWM mode application circuit is configured by applying an external voltage to the control pin. Usually, a capacitance of 0.01 μF is connected as shown in the application circuit.

ELECTRICAL CHARACTERISTICS ( $T_A = 25^\circ\text{C}$ ,  $V_{CC} = 5$  to  $15$  V)

Parameter	Symbol	Conditions	MIN.	TYP.	MAX.	Unit
Supply voltage	$V_{CC}$		4.5		16	V
Supply current	$I_{CC}$	$V_{CC} = 5$ V, $R_L = \infty$ , $V_O = \text{"L"}$ Note 6	0	3	6	mA
		$V_{CC} = 15$ V, $R_L = \infty$ , $V_O = \text{"L"}$ Note 6	0	10	15	mA
Threshold voltage	$V_{th}$			$2/3 V_{CC}$		V
Threshold current	$I_{th}$	Note 7	0	0.1	0.25	$\mu\text{A}$
Trigger voltage	$V_{tr}$	$V_{CC} = 15$ V		5		V
		$V_{CC} = 5$ V		1.67		V
Trigger current	$I_{tr}$			0.5		$\mu\text{A}$
Reset voltage	$V_{reset}$	Note 8	0.4	0.7	1.0	V
Reset current	$I_{reset}$			0.1		mA
Control voltage	$V_{cont}$	$V_{CC} = 15$ V	9.0	10	11	V
		$V_{CC} = 5$ V	2.6	3.33	4	V
Output saturation voltage "L"	$V_{OL}$	$V_{CC} = 15$ V, $I_{SINK} = 10$ mA	0	0.1	0.25	V
		$V_{CC} = 15$ V, $I_{SINK} = 50$ mA	0	0.4	0.75	V
		$V_{CC} = 15$ V, $I_{SINK} = 100$ mA	0	2.0	2.5	V
		$V_{CC} = 15$ V, $I_{SINK} = 200$ mA		2.5		V
		$V_{CC} = 5$ V, $I_{SINK} = 5$ mA	0	0.1	0.35	V
Output saturation voltage "H"	$V_{OH}$	$V_{CC} = 15$ V, $I_{SOURCE} = 200$ mA		12.5		V
		$V_{CC} = 15$ V, $I_{SOURCE} = 100$ mA	12.75	13.3	15.0	V
		$V_{CC} = 5$ V, $I_{SOURCE} = 100$ mA	2.75	3.3	5.0	V
Propagation delay (L $\rightarrow$ H)	$t_{PLH}$			200		ns
Propagation delay (H $\rightarrow$ L)	$t_{PHL}$			200		ns
Minimum trigger pulse width	$t_{w(tr)}$	$V_{CC} = 15$ V, $V_{tr min.} = 2.5$ V		25		ns
Minimum output pulse width	$t_{w(OUT)}$	$V_{CC} = 15$ V, $V_{tr min.} = 2.5$ V $t_{w(tr)} = 3 \mu\text{s}$		6		$\mu\text{s}$
Minimum reset pulse width	$t_{w(reset)}$	$V_{CC} = 15$ V, $V_{tr min.} = 0$ V		900		ns
Timing error		Astable multivibrator				
Initial accuracy		$R_A, R_B = 1$ to $100$ k $\Omega$		1		%
Temperature drift		$C = 0.1 \mu\text{F}$		50		ppm/ $^\circ\text{C}$
Supply voltage drift				0.01		%/V

**Notes 6.** When the output is "H", the circuit current decreases by approximately 1 mA (when  $V_{CC} = 5$  V).

**7.** The maximum allowable value for  $R_A + R_B$  is determined for a supply voltage of 15 V. The maximum value is 20 M $\Omega$ .

**8.** When the reset pin is driven to a low level, discharge T $\cdot$ Q $_{14}$  is turned on, stopping oscillation (the output state is undefined).

CHARACTERISTIC CURVES (T<sub>A</sub> = 25°C, TYP.)

Minimum trigger pulse width characteristic

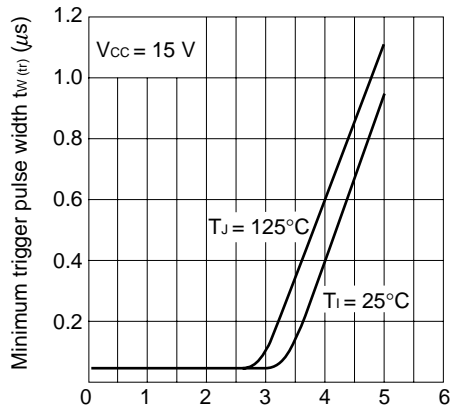

Minimum trigger pulse voltage  $V_{tr min.}$  (V)

I<sub>CC</sub>-V<sub>CC</sub> characteristic

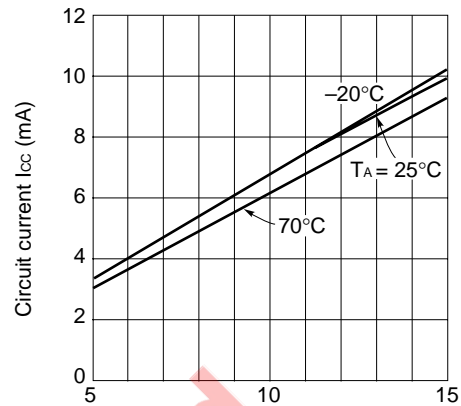

Supply voltage  $V_{CC}$  (V)

I<sub>SOURCE</sub>-(V<sub>CC</sub>-V<sub>OUT</sub>) characteristic

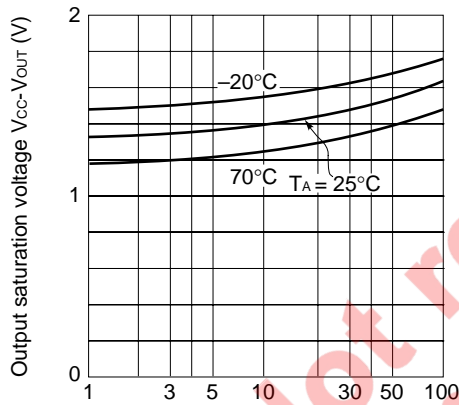

Output source current  $I_{SOURCE}$  (mA)

I<sub>SINK</sub>-V<sub>OUT</sub> characteristic

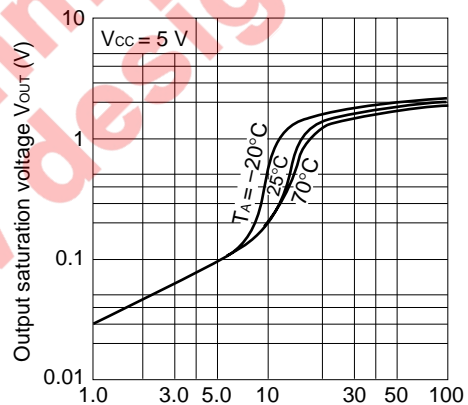

Output sink current  $I_{SINK}$  (mA)

I<sub>SINK</sub>-V<sub>OUT</sub> characteristic

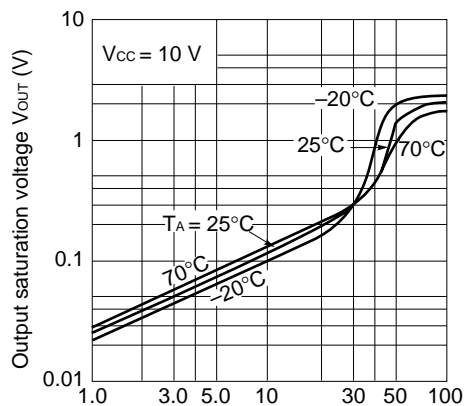

Output sink current  $I_{SINK}$  (mA)

I<sub>SINK</sub>-V<sub>OUT</sub> characteristic

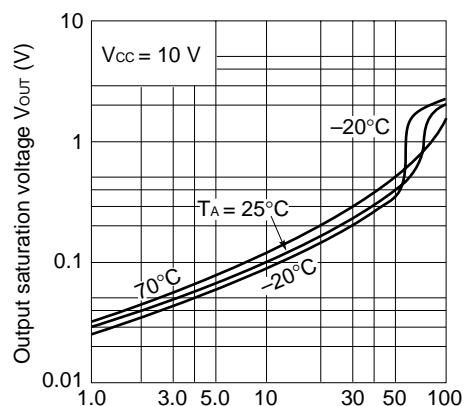

Output sink current  $I_{SINK}$  (mA)

Propagation delay characteristic

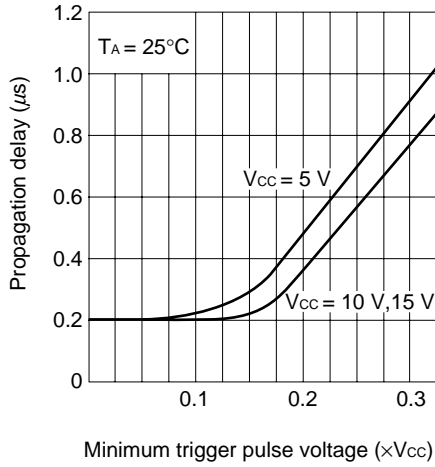

Discharge pin  $I_{SINK}$ - $V_{SAT}$  characteristic

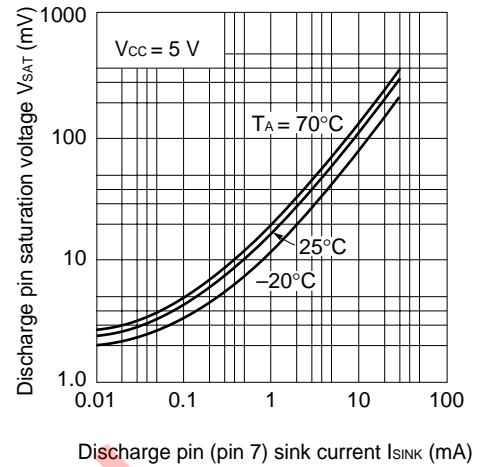

$P_T$ - $T_A$  characteristic

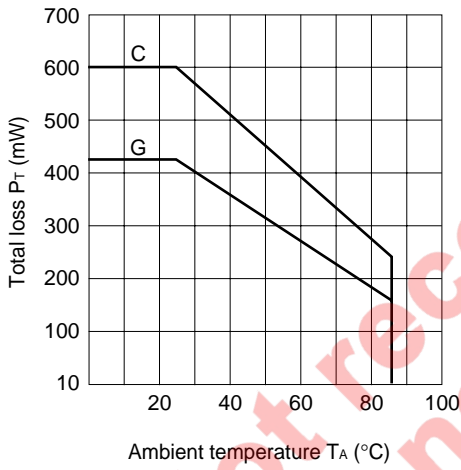

$\Delta tw$ - $t_w$  ( $t_r$ ) characteristic

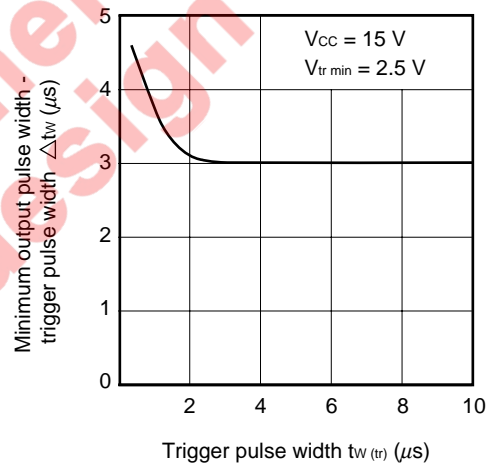

$\Delta tw$ - $t_{tr\ min}$  characteristic

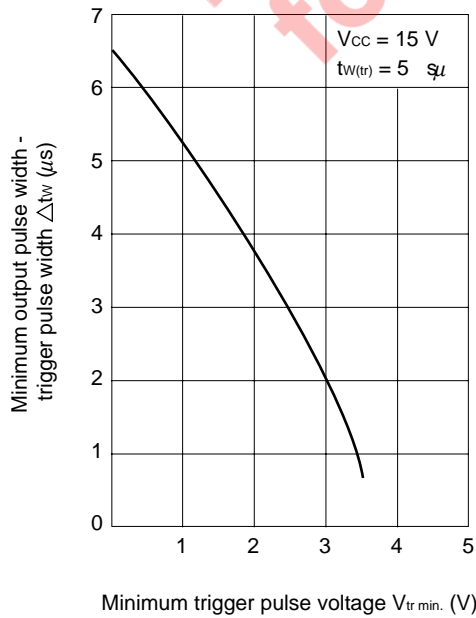

**PIN FUNCTIONS**

1. Trigger pin (pin 2) : Supplying one-third of  $V_{CC}$  to the trigger pin triggers the circuit, changing the output voltage from low to high.
2. Output pin (pin 3) : The maximum output current is 200 mA. Be careful not to exceed the total loss (see the  $P_T-T_A$  characteristic curve).
3. Reset pin (pin 4) : Supplying 0.4 V or less to the reset pin stops the circuit operation (such as monostable or astable multivibrator operation).  
When not used, the reset pin should be clamped at 1 V to  $V_{CC}$ .
4. Control voltage (pin 5) : This voltage determines the threshold level of the comparator. It is set to two-thirds of  $V_{CC}$ . It is possible to configure a PWM (pulse width modulation) or PPM (pulse position modulation) mode application circuit by supplying a control voltage from the outside. When this pin is not in use, it should be bypassed using a capacitor of approximately 0.01  $\mu$ F for more stable circuit operation.
5. Threshold pin (pin 6) : The values of an external capacitor (C) and resistor (R) connected to this pin determine the width of the output pulse.
6. Discharge pin (pin 7) : This pin is used to discharge an external capacitor (if connected). It operates, when the internal flip-flop circuit is turned on, or a reset signal is applied.

Not recommended  
for new design



APPLICATION CIRCUITS

(1) Monostable multivibrator

Fig. a Monostable Multivibrator Example

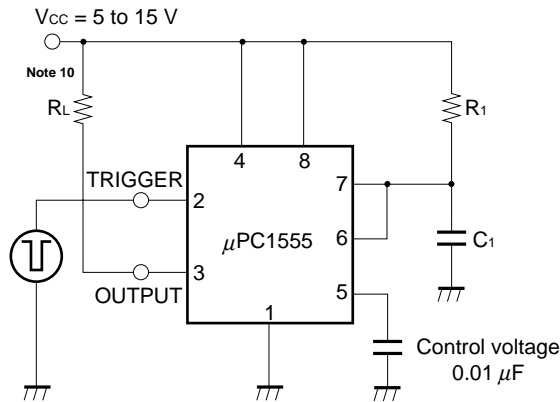

When the μPC1555 is configured as shown in Fig. a, it functions as a monostable multivibrator. Applying a voltage one-third as high as Vcc or less (trigger pulse<sup>Note 9</sup>) to pin 2 (trigger pin) drives the output to a high level. Under this condition, capacitor C1 starts charging through resistor R1. When C1 is charged up to two-thirds as high as Vcc, pin 6 (threshold pin) is turned on and inverted to a low level. At this point, C1 starts discharging through pin 7. When a trigger pulse is applied to pin 2 again, the same operation is repeated. Fig. b shows this operation. A capacitor connected to pin 5 functions as a nose filter for the control voltage. If pin 4 (reset pin) is connected to 1 V or higher (for example, by being connected to Vcc), the circuit operation can be stopped by switching it from 2 V or higher to a GND level.

The output pulse width (delay) is determined theoretically by (see Fig. c):

$$t = 1.1 \cdot C_1 \cdot R_1$$

The value obtained by this equation is only an approximate value, however. If it is necessary to obtain an accurate output pulse width, determine R1 and C1 through actual measurement and confirmation; a trimmer should be used as required. Moreover, R1 should be 300 Ω or higher.

**Notes 9.** Keep the trigger pulse width smaller than the output pulse width.

**10.** If the load is connected across the output and GND pins, a “staircase” occurs in the output waveform.

The application circuits and their parameters are for references only and are not intended for use in actual design-in's.

Fig. b Monostable Response Waveform

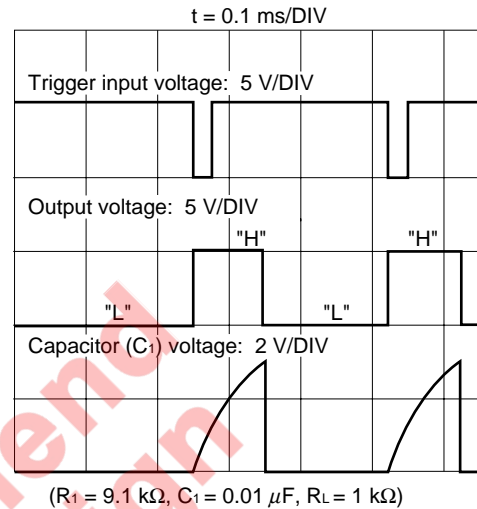
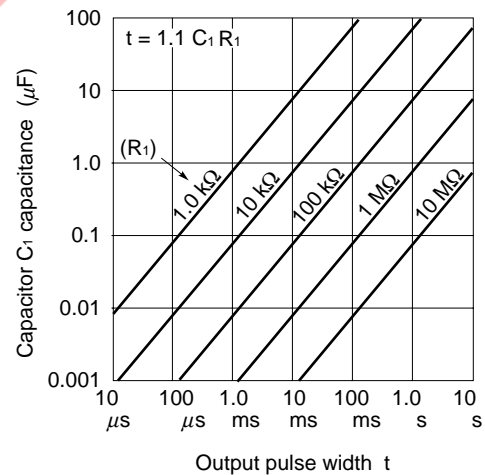

Fig. c Interrelationships among Output Pulse Width, R1, and C1 (approximate value obtained by calculation)



(2) Astable multivibrator example

Fig. d Astable Multivibrator Example

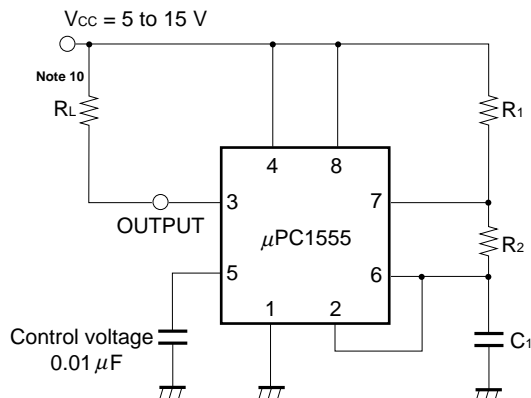
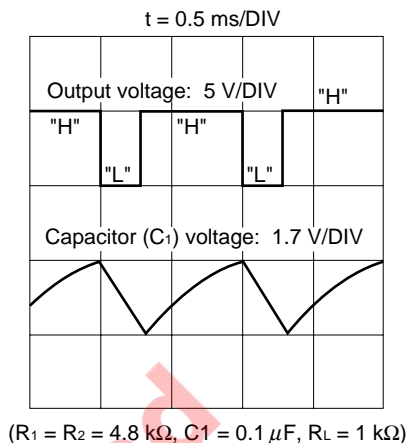
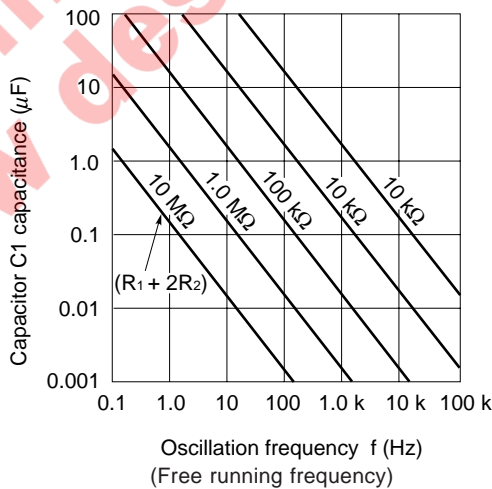

Fig. e Astable Multivibrator Response Waveform



When the μPC1555 is used in a circuit configuration shown in Fig. d, the circuit is triggered by itself to operate as an astable multivibrator, because pin 2 (trigger pin) and pin 6 (threshold pin) are connected to each other. When the output voltage is high, capacitor C1 is charged through R1 and R2. When C1 is charged up to a voltage two-thirds as high as Vcc, the threshold pin is turned on, and the output pin becomes low. At this point C1 starts discharging through R2. When C1 discharges, and the voltage across C1 decreases to a voltage one-third as high as Vcc, the trigger pin is turned on, and the output voltage becomes high, causing the charge current to flow into C1 through R1 and R2 again. This operation is shown in Fig. e. Because C1 repeats charging and discharging between one-third as high as Vcc and two-thirds as high as Vcc, the oscillation frequency is not affected by the supply voltage.

Fig. f Interrelationships among Oscillation Frequency, R1, R2, and C1 (approximate value obtained by calculation)



Oscillation is represented theoretically using the following expressions.

When the output voltage is high, the charge time is :  $t_1 = 0.693 (R_1 + R_2) C_1$  ..... (1)

When the output voltage is low, the discharge time is :  $t_2 = 0.693 \cdot R_2 \cdot C_1$  ..... (2)

Adding expressions (1) and (2) determines period T :  $T = t_1 + t_2 = 0.693 (R_1 + 2R_2) C_1$  ..... (3)

Therefore, the oscillation frequency is (see Fig. f for reference)

$$f = \frac{1}{T} = \frac{1.44}{(R_1 + 2R_2) C_1} \text{ ..... (4)}$$

The duty cycle is determined by the equation (5)

$$D = \frac{R_2}{R_1 + 2R_2} \text{ ..... (5)}$$

The values obtained this way are approximate values, however. If it is necessary to obtain an accurate oscillation frequency, determine R1, R2, and C1 through actual measurement and confirmation; a trimmer should be used as required. Moreover, R1 and R2 should be 300 Ω or higher.

**Note 10.** If the load is connected across the output and GND pins, a “staircase” occurs in the output waveform.

8PIN PLASTIC DIP (300 mil)

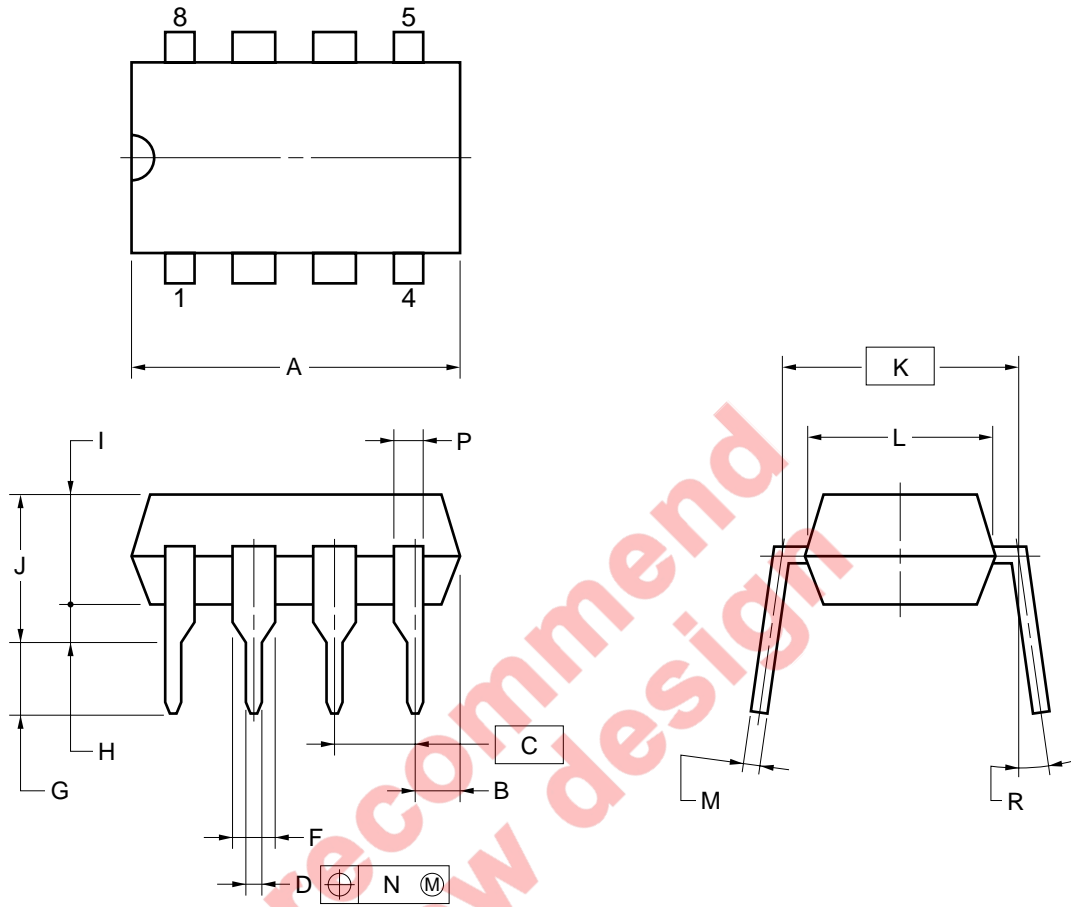

NOTES

- 1) Each lead centerline is located within 0.25 mm (0.01 inch) of its true position (T.P.) at maximum material condition.
- 2) Item "K" to center of leads when formed parallel.

ITEM	MILLIMETERS	INCHES
A	10.16 MAX.	0.400 MAX.
B	1.27 MAX.	0.050 MAX.
C	2.54 (T.P.)	0.100 (T.P.)
D	0.50±0.10	0.020 <sup>+0.004</sup> <sub>-0.005</sub>
F	1.4 MIN.	0.055 MIN.
G	3.2±0.3	0.126±0.012
H	0.51 MIN.	0.020 MIN.
I	4.31 MAX.	0.170 MAX.
J	5.08 MAX.	0.200 MAX.
K	7.62 (T.P.)	0.300 (T.P.)
L	6.4	0.252
M	0.25 <sup>+0.10</sup> <sub>-0.05</sub>	0.010 <sup>+0.004</sup> <sub>-0.003</sub>
N	0.25	0.01
P	0.9 MIN.	0.035 MIN.
R	0-15°	0-15°

P8C-100-300B,C-1

8 PIN PLASTIC SOP (225 mil)

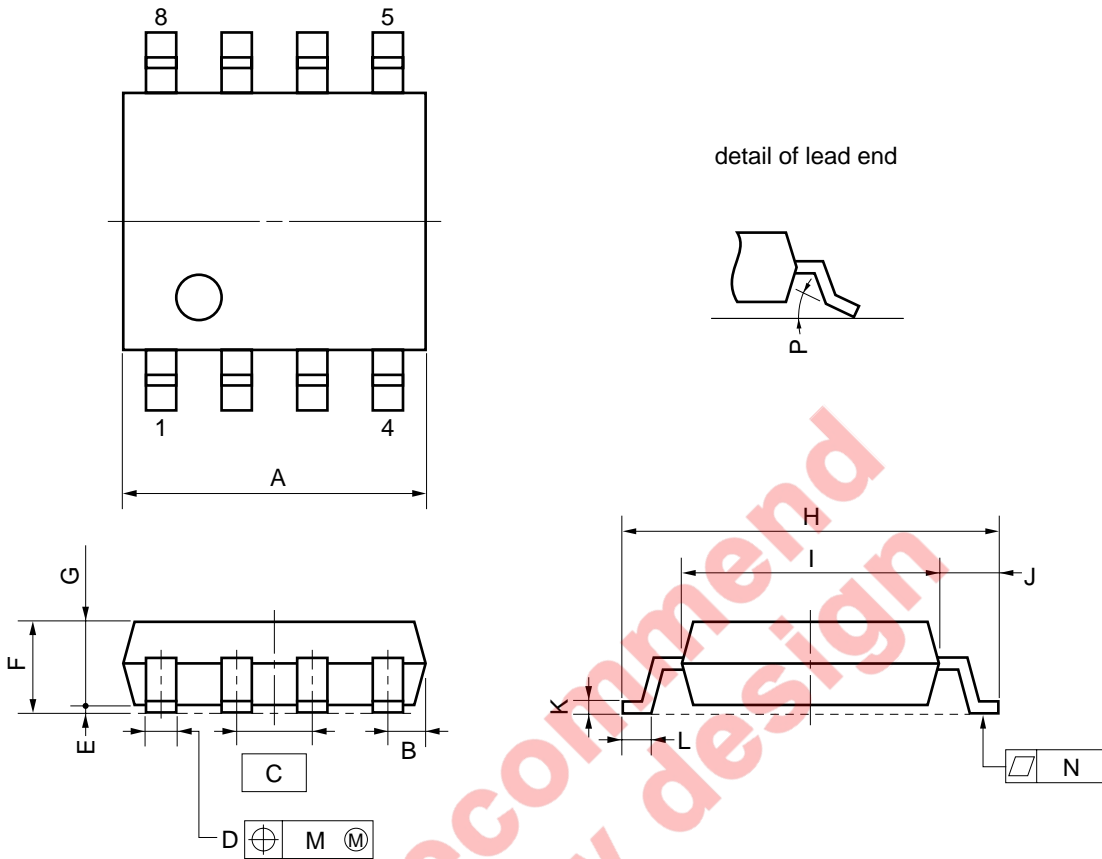

**NOTE**

Each lead centerline is located within 0.12 mm (0.005 inch) of its true position (T.P.) at maximum material condition.

ITEM	MILLIMETERS	INCHES
A	5.37 MAX.	0.212 MAX.
B	0.78 MAX.	0.031 MAX.
C	1.27 (T.P.)	0.050 (T.P.)
D	0.40 <sup>+0.10</sup> <sub>-0.05</sub>	0.016 <sup>+0.004</sup> <sub>-0.003</sub>
E	0.1±0.1	0.004±0.004
F	1.8 MAX.	0.071 MAX.
G	1.49	0.059
H	6.5±0.3	0.256±0.012
I	4.4	0.173
J	1.1	0.043
K	0.15 <sup>+0.10</sup> <sub>-0.05</sub>	0.006 <sup>+0.004</sup> <sub>-0.002</sub>
L	0.6±0.2	0.024 <sup>+0.008</sup> <sub>-0.009</sub>
M	0.12	0.005
N	0.10	0.004
P	3° <sup>+7°</sup> <sub>-3°</sub>	3° <sup>+7°</sup> <sub>-3°</sub>

S8GM-50-225B-4

**RECOMMENDED SOLDERING CONDITIONS**

The conditions listed below shall be met when soldering the μPC1555.

Please consult with our sales offices in case any other soldering process is used, or in case soldering is done under different conditions.

**Surface-Mount Devices**

For details of the recommended soldering conditions, refer to our document *SMD Surface Mount Technology Manual* (IEI-1207).

μPC1555G2

Soldering process	Soldering conditions	Symbol
Infrared reflow	Peak package's surface temperature: 230°C Reflow time: 30 seconds or less (at 210°C or more) Maximum allowable number of reflow processes: 1 Exposure limit: None <sup>Note</sup>	IR30-00
VPS	Peak package's surface temperature: 215°C Reflow time: 40 seconds or less (at 200°C or more) Maximum allowable number of reflow processes: 1 Exposure limit: None <sup>Note</sup>	VP15-00
Wave soldering	Temperature in the soldering vessel: 260°C or less Soldering time: 10 seconds or less Maximum allowable number of reflow processes: 1 Exposure limit: None <sup>Note</sup>	WS60-00
Partial heating method	Pin temperature: 300°C or less Flow time: 10 seconds or less Exposure limit: None <sup>Note</sup>	

**Note** Exposure limit before soldering after dry-pack package is opened.

Storage conditions: Temperature of 25°C or less and maximum relative humidity of 65% or less

**Caution** Do not apply more than a single process at once, except for "Partial heating method."

**Through-Hole Mount Devices**

μPC1555C

Soldering process	Soldering conditions
Wave soldering	Temperature in the soldering vessel: 260°C or less Soldering time: 10 seconds or less

**REFERENCE**

Document name	Document No.
NEC Semiconductor Device Reliability/Quality Control System	IEI-1212
Quality Grade on NEC Semiconductor Devices	IEI-1209
Semiconductor Device Mounting Technology Manual	IEI-1207
Semiconductor Device Package Manual	IEI-1213
Guide to Quality Assurance for Semiconductor Devices	MEI-1202
Semiconductor Selection Guide	MF-1134

## [MEMO]

No part of this document may be copied or reproduced in any form or by any means without the prior written consent of NEC Corporation. NEC Corporation assumes no responsibility for any errors which may appear in this document.

NEC Corporation does not assume any liability for infringement of patents, copyrights or other intellectual property rights of third parties by or arising from use of a device described herein or any other liability arising from use of such device. No license, either express, implied or otherwise, is granted under any patents, copyrights or other intellectual property rights of NEC Corporation or others.

While NEC Corporation has been making continuous effort to enhance the reliability of its semiconductor devices, the possibility of defects cannot be eliminated entirely. To minimize risks of damage or injury to persons or property arising from a defect in an NEC semiconductor device, customer must incorporate sufficient safety measures in its design, such as redundancy, fire-containment, and anti-failure features.

NEC devices are classified into the following three quality grades:

“Standard”, “Special”, and “Specific”. The Specific quality grade applies only to devices developed based on a customer designated “quality assurance program” for a specific application. The recommended applications of a device depend on its quality grade, as indicated below. Customers must check the quality grade of each device before using it in a particular application.

Standard: Computers, office equipment, communications equipment, test and measurement equipment, audio and visual equipment, home electronic appliances, machine tools, personal electronic equipment and industrial robots

Special: Transportation equipment (automobiles, trains, ships, etc.), traffic control systems, anti-disaster systems, anti-crime systems, safety equipment and medical equipment (not specifically designed for life support)

Specific: Aircrafts, aerospace equipment, submersible repeaters, nuclear reactor control systems, life support systems or medical equipment for life support, etc.

The quality grade of NEC devices in “Standard” unless otherwise specified in NEC's Data Sheets or Data Books. If customers intend to use NEC devices for applications other than those specified for Standard quality grade, they should contact NEC Sales Representative in advance.

Anti-radioactive design is not implemented in this product.