

To our customers,

Old Company Name in Catalogs and Other Documents

On April 1st, 2010, NEC Electronics Corporation merged with Renesas Technology Corporation, and Renesas Electronics Corporation took over all the business of both companies. Therefore, although the old company name remains in this document, it is a valid Renesas Electronics document. We appreciate your understanding.

Renesas Electronics website: <http://www.renesas.com>

April 1st, 2010
Renesas Electronics Corporation

Issued by: Renesas Electronics Corporation (<http://www.renesas.com>)

Send any inquiries to <http://www.renesas.com/inquiry>.

Notice

1. All information included in this document is current as of the date this document is issued. Such information, however, is subject to change without any prior notice. Before purchasing or using any Renesas Electronics products listed herein, please confirm the latest product information with a Renesas Electronics sales office. Also, please pay regular and careful attention to additional and different information to be disclosed by Renesas Electronics such as that disclosed through our website.
2. Renesas Electronics does not assume any liability for infringement of patents, copyrights, or other intellectual property rights of third parties by or arising from the use of Renesas Electronics products or technical information described in this document. No license, express, implied or otherwise, is granted hereby under any patents, copyrights or other intellectual property rights of Renesas Electronics or others.
3. You should not alter, modify, copy, or otherwise misappropriate any Renesas Electronics product, whether in whole or in part.
4. Descriptions of circuits, software and other related information in this document are provided only to illustrate the operation of semiconductor products and application examples. You are fully responsible for the incorporation of these circuits, software, and information in the design of your equipment. Renesas Electronics assumes no responsibility for any losses incurred by you or third parties arising from the use of these circuits, software, or information.
5. When exporting the products or technology described in this document, you should comply with the applicable export control laws and regulations and follow the procedures required by such laws and regulations. You should not use Renesas Electronics products or the technology described in this document for any purpose relating to military applications or use by the military, including but not limited to the development of weapons of mass destruction. Renesas Electronics products and technology may not be used for or incorporated into any products or systems whose manufacture, use, or sale is prohibited under any applicable domestic or foreign laws or regulations.
6. Renesas Electronics has used reasonable care in preparing the information included in this document, but Renesas Electronics does not warrant that such information is error free. Renesas Electronics assumes no liability whatsoever for any damages incurred by you resulting from errors in or omissions from the information included herein.
7. Renesas Electronics products are classified according to the following three quality grades: “Standard”, “High Quality”, and “Specific”. The recommended applications for each Renesas Electronics product depends on the product’s quality grade, as indicated below. You must check the quality grade of each Renesas Electronics product before using it in a particular application. You may not use any Renesas Electronics product for any application categorized as “Specific” without the prior written consent of Renesas Electronics. Further, you may not use any Renesas Electronics product for any application for which it is not intended without the prior written consent of Renesas Electronics. Renesas Electronics shall not be in any way liable for any damages or losses incurred by you or third parties arising from the use of any Renesas Electronics product for an application categorized as “Specific” or for which the product is not intended where you have failed to obtain the prior written consent of Renesas Electronics. The quality grade of each Renesas Electronics product is “Standard” unless otherwise expressly specified in a Renesas Electronics data sheets or data books, etc.
 - “Standard”: Computers; office equipment; communications equipment; test and measurement equipment; audio and visual equipment; home electronic appliances; machine tools; personal electronic equipment; and industrial robots.
 - “High Quality”: Transportation equipment (automobiles, trains, ships, etc.); traffic control systems; anti-disaster systems; anti-crime systems; safety equipment; and medical equipment not specifically designed for life support.
 - “Specific”: Aircraft; aerospace equipment; submersible repeaters; nuclear reactor control systems; medical equipment or systems for life support (e.g. artificial life support devices or systems), surgical implantations, or healthcare intervention (e.g. excision, etc.), and any other applications or purposes that pose a direct threat to human life.
8. You should use the Renesas Electronics products described in this document within the range specified by Renesas Electronics, especially with respect to the maximum rating, operating supply voltage range, movement power voltage range, heat radiation characteristics, installation and other product characteristics. Renesas Electronics shall have no liability for malfunctions or damages arising out of the use of Renesas Electronics products beyond such specified ranges.
9. Although Renesas Electronics endeavors to improve the quality and reliability of its products, semiconductor products have specific characteristics such as the occurrence of failure at a certain rate and malfunctions under certain use conditions. Further, Renesas Electronics products are not subject to radiation resistance design. Please be sure to implement safety measures to guard them against the possibility of physical injury, and injury or damage caused by fire in the event of the failure of a Renesas Electronics product, such as safety design for hardware and software including but not limited to redundancy, fire control and malfunction prevention, appropriate treatment for aging degradation or any other appropriate measures. Because the evaluation of microcomputer software alone is very difficult, please evaluate the safety of the final products or system manufactured by you.
10. Please contact a Renesas Electronics sales office for details as to environmental matters such as the environmental compatibility of each Renesas Electronics product. Please use Renesas Electronics products in compliance with all applicable laws and regulations that regulate the inclusion or use of controlled substances, including without limitation, the EU RoHS Directive. Renesas Electronics assumes no liability for damages or losses occurring as a result of your noncompliance with applicable laws and regulations.
11. This document may not be reproduced or duplicated, in any form, in whole or in part, without prior written consent of Renesas Electronics.
12. Please contact a Renesas Electronics sales office if you have any questions regarding the information contained in this document or Renesas Electronics products, or if you have any other inquiries.

(Note 1) “Renesas Electronics” as used in this document means Renesas Electronics Corporation and also includes its majority-owned subsidiaries.

(Note 2) “Renesas Electronics product(s)” means any product developed or manufactured by or for Renesas Electronics.



V55PI™ 16-BIT MICROPROCESSOR

DESCRIPTION

The μ PD70433 (V55PI) is a microprocessor in which a 16-bit CPU, RAM, serial interface, parallel interface, A/D converter, timers, DMA controller, interrupt controller, etc., are integrated in a single chip.

The V55PI is software-compatible with the μ PD70320 and 70330 (V25™ and V35™) single-chip microcontrollers. The V55PI provides a migration path from the V25. It offers higher-level functions and higher performance, and is particularly suitable for control of data processing systems associated with mechanical control, including printer and facsimile.

Detailed functions are described in the following user's manuals, which should be read when carrying out design work.

- V55PI User's Manual Hardware : U10514E
- V55PI User's Manual Instruction : U10231E

FEATURES

- Internal 16-bit architecture, selectable external data bus width (16/8 bits)
- Software compatible with V20™ and V30™ (native mode) and V25 and V35 (includes additional instructions)
- Minimum instruction cycle: 160 ns/12.5 MHz (external 25 MHz)
125 ns/16 MHz (external 32 MHz)
- Address space: 16M bytes:
 - 1-Mbyte basic memory space
 - 16-Mbyte extended memory space
- Register file space (in on-chip RAM) : 512 bytes/16 register banks
- I/O space : 64K bytes
- Automatic wait control with memory space divided in variable sizes (max. 6 blocks)
- I/O line (input ports: 11 bits, input/output ports: 42 bits)
- DMA controller (DMAC): Max. 4-channel configuration possible
 - Four DMA transfer modes (single transfer, demand release, single step, burst)
 - Intelligent DMA modes 1 and 2
- Serial interface: 2 channels
 - Asynchronous mode (UART) or clocked mode (CSI) selectable
- Parallel interface: 8 bits
 - Centronics data input/output and general-purpose data input/output
- A/D converter (8 bits): 4 channels
- Real-time output port: 4 bits \times 2 channels or 8 bits \times 1 channel
- PMW (Pulse Width Modulation) output function : 8 bits

The information in this document is subject to change without notice.

- Interrupt controller
 - Programmable priority (4 levels)
 - Three interrupt servicing methods
 - Vectored interrupt function, register bank switching function, macro service function
- 16-bit timer: 4 channels
- Watchdog timer function
- Software interval timer (16 bits)
- Address field wait insertion function and RAS/CAS switchover timing generation function
- DRAM and pseudo-SRAM refresh functions
- Standby functions (STOP mode, HALT mode)
- On-chip clock generator

APPLICATIONS

- Control of data processing systems using serial or parallel communication
(Data processing terminals, printer, G3 facsimile, etc.)

★ ORDERING INFORMATION

Part Number	Package	Maximum Operating Frequency (MHz)
μ PD70433GD-12-5BB	120-pin plastic QFP (28 × 28 mm)	12.5
μ PD70433GD-16-5BB	120-pin plastic QFP (28 × 28 mm)	16
μ PD70433R-12	132-pin ceramic PGA	12.5
μ PD70433R-16	132-pin ceramic PGA	16
μ PD70433GJ-12-3EB	120-pin plastic QFP (fine pitch) (20 × 20 mm)	12.5
μ PD70433GJ-16-3EB	120-pin plastic QFP (fine pitch) (20 × 20 mm)	16

PIN CONFIGURATION (TOP VIEW)

(1) 120-Pin Plastic QFP (28 × 28 mm), 120-pin plastic QFP (fine pitch) (20 × 20 mm)

μPD70433GD-xx-5BB

μPD70433GJ-xx-3EB

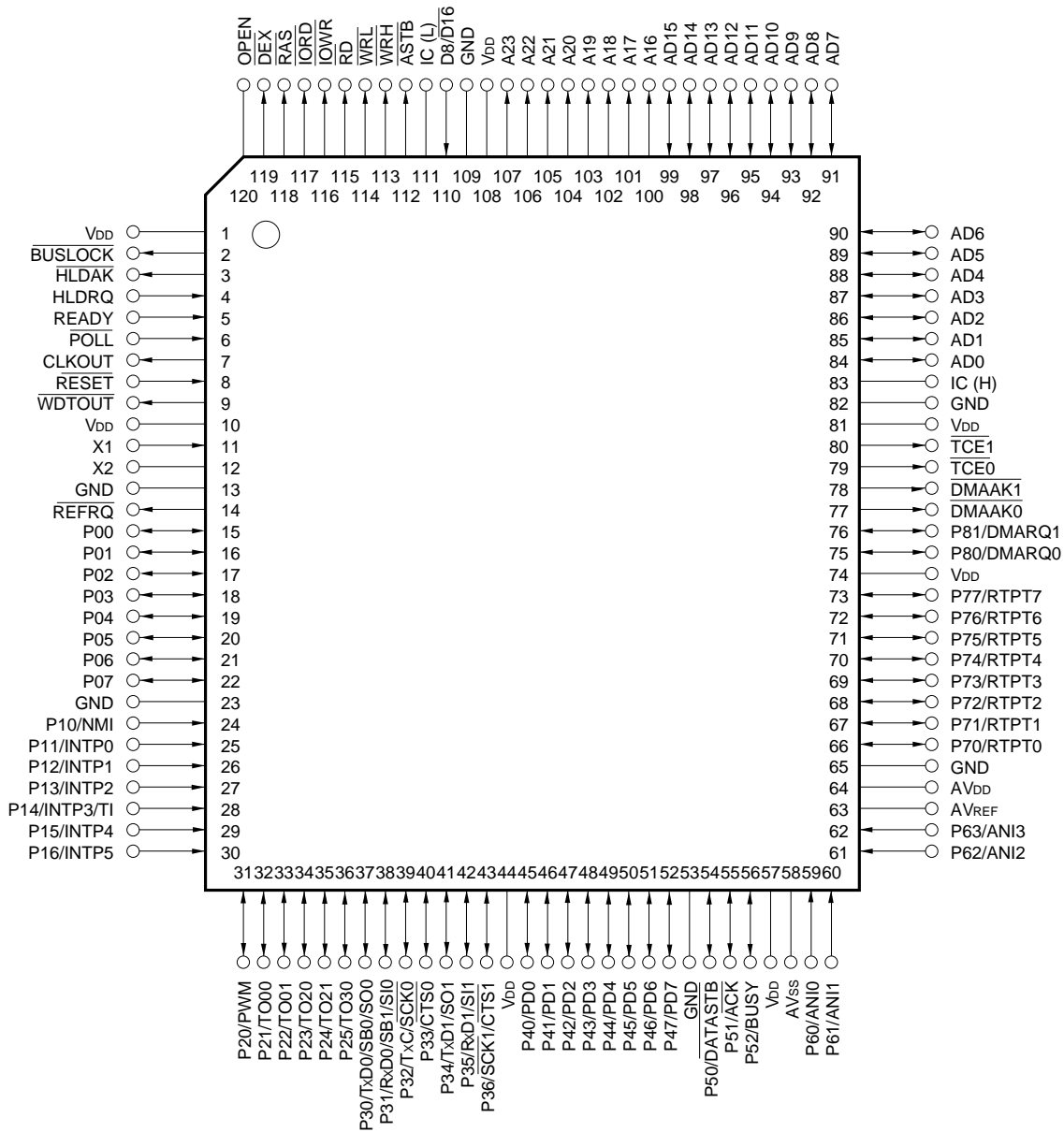

Remark IC: Internally Connected

- Notes**
1. The IC (H) pin should be connected to V_{DD} with an external resistor (1 to 10 kΩ).
 2. The IC (L) pin should be connected to GND with an external resistor (1 to 10 kΩ).
 3. No connection should be made to the OPEN pin.

(2) 132-Pin Ceramic PGA

μPD70433R-xx

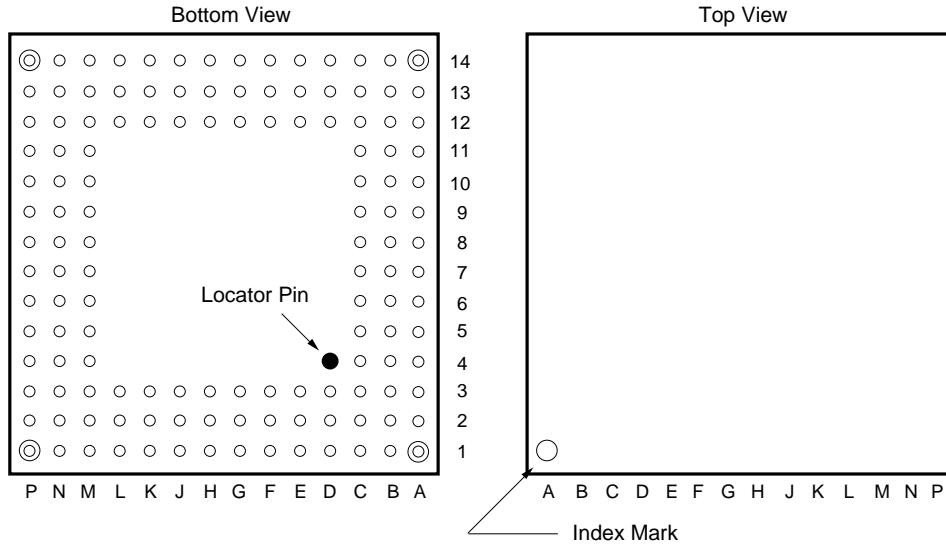

Remark The locator pin is not included in the pin count.

No.	Signal Name	Port	No.	Signal Name	Port	No.	Signal Name	Port
A1	ANI1	P61	B5	PD7	P47	C9	CTS0	P33
A2	AV _{SS}	—	B6	PD5	P45	C10	TO30	P25
A3	ACK	P51	B7	PD2	P42	C11	TO00	P21
A4	DATA _{STB}	P50	B8	PD0	P40	C12	NC	—
A5	PD6	P46	B9	RxD1/SI1	P35	C13	INTP4	P15
A6	PD4	P44	B10	RxD0/SB1/SI0	P31	C14	INTP0	P11
A7	PD1	P41	B11	TO21	P24	D1	RTPT2	P72
A8	NC	—	B12	TO01	P22	D2	GND	—
A9	SCK1/CTS1	P36	B13	NC	—	D3	ANI3	P63
A10	TxD1/SO1	P34	B14	INTP3/TI	P14	D12	INTP5	P16
A11	TxC/SCK0	P32	C1	RTPT1	P71	D13	INTP2	P13
A12	TxD0/SB0/SO0	P30	C2	AV _{REF}	—	D14	NMI	P10
A13	TO20	P23	C3	NC	—	E1	RTPT5	P75
A14	PWM	P20	C4	NC	—	E2	RTPT3	P73
B1	AV _{DD}	—	C5	V _{DD}	—	E3	RTPT0	P70
B2	ANI2	P62	C6	GND	—	E12	INTP1	P12
B3	ANI0	P60	C7	PD3	P43	E13	GND	—
B4	BUSY	P52	C8	V _{DD}	—	E14	—	P06

No.	Signal Name	Port	No.	Signal Name	Port	No.	Signal Name	Port
F1	RTPT7	P77	K3	AD2	—	N3	AD9	—
F2	RTPT6	P76	K12	POLL	—	N4	AD11	—
F3	RTPT4	P74	K13	WDTOUT	—	N5	AD14	—
F12	—	P07	K14	X1	—	N6	A18	—
F13	—	P05	L1	AD0	—	N7	A21	—
F14	—	P04	L2	AD3	—	N8	A23	—
G1	NC	—	L3	AD6	—	N9	D8/D16	—
G2	DMARQ0	P80	L12	BUSLOCK	—	N10	ASTB	—
G3	V _{DD}	—	L13	READY	—	N11	IOWR	—
G12	—	P03	L14	RESET	—	N12	DEX	—
G13	—	P02	M1	AD1	—	N13	V _{DD}	—
G14	—	P01	M2	AD5	—	N14	HLDRQ	—
H1	DMARQ1	P81	M3	NC	—	P1	AD7	—
H2	DMAAK0	—	M4	AD8	—	P2	AD10	—
H3	DMAAK1	—	M5	AD12	—	P3	AD13	—
H12	REFRQ	—	M6	A16	—	P4	AD15	—
H13	—	P00	M7	A20	—	P5	A17	—
H14	NC	—	M8	V _{DD}	—	P6	A19	—
J1	TCE0	—	M9	WRH	—	P7	NC	—
J2	TCE1	—	M10	IORD	—	P8	A22	—
J3	GND	—	M11	NC	—	P9	GND	—
J12	V _{DD}	—	M12	NC	—	P10	IC (L)	—
J13	X2	—	M13	HLDAK	—	P11	WRL	—
J14	GND	—	M14	CLKOUT	—	P12	R _D	—
K1	V _{DD}	—	N1	AD4	—	P13	RAS	—
K2	IC (H)	—	N2	NC	—	P14	OPEN	—

Remark IC: Internally Connected
NC: Non-Connection

- Notes**
1. The IC (H) pin should be connected to V_{DD} with an external resistor (1 to 10 kΩ).
 2. The IC (L) pin should be connected to GND with an external resistor (1 to 10 kΩ).
 3. No connection should be made to the OPEN pin.

Phase-out/Discontinued

INTERNAL BLOCK DIAGRAM

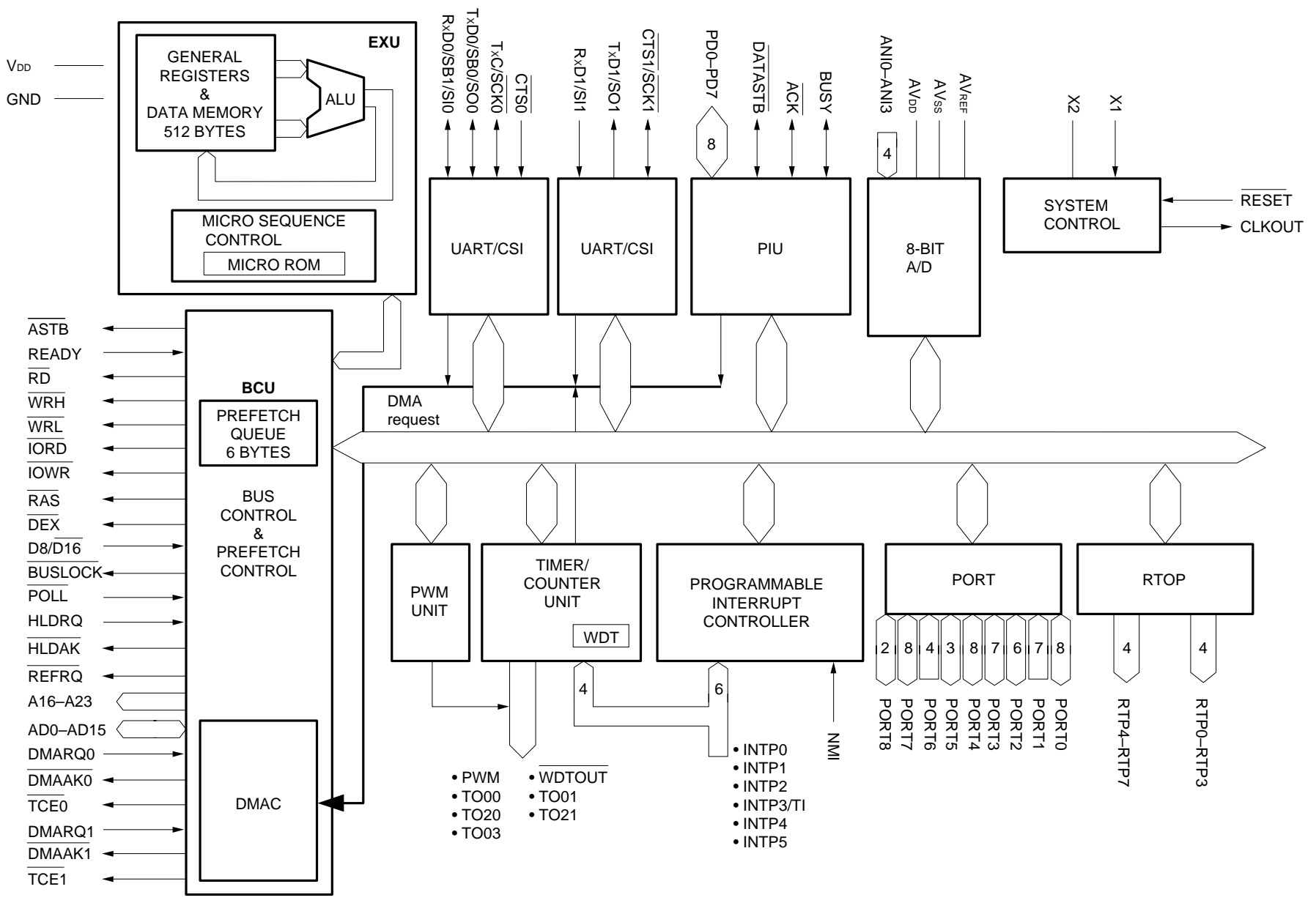

CONTENTS

- 1. PIN FUNCTIONS 10
 - 1.1 LIST OF PIN FUNCTION 10
 - 1.1.1 Port Pins 10
 - 1.1.2 Non-Port Pins 11

- 2. BLOCK CONFIGURATION 14
 - 2.1 BUS CONTROL UNIT (BCU) 14
 - 2.2 EXECUTION UNIT (EXU) 14
 - 2.3 INTERRUPT CONTROLLER (INTC) 14
 - 2.4 DMA CONTROLLER (DMAC) 14
 - 2.5 UART/CLOCKED SERIAL INTERFACE (UART/CSI) 14
 - 2.6 PARALLEL INTERFACE UNIT (PIU) 14
 - 2.7 A/D CONVERTER UNIT (8-BIT A/D) 14
 - 2.8 TIMER/COUNTER UNIT (TCU) 14
 - 2.9 PWM (PULSE WIDTH MODULATION) UNIT (PWM) 14
 - 2.10 WATCHDOG TIMER (WDT) 14
 - 2.11 PORTS (PORT) 14
 - 2.12 REAL-TIME OUTPUT PORT (RTOP) 14
 - 2.13 CLOCK GENERATOR (CG) 15
 - 2.14 SOFTWARE INTERVAL TIMER (SIT) 15

- 3. CPU FUNCTIONS 16
 - 3.1 FEATURES 16
 - 3.2 REGISTERS 17
 - 3.2.1 Register Banks 17
 - 3.2.2 General Registers (AW, BW, CW, DW) 19
 - 3.2.3 Pointers (SP, BP) and Index Registers (IX, IY) 20
 - 3.2.4 Segment Registers (PS, SS, DS0, DS1) 20
 - 3.2.5 Extended Segment Registers (DS2, DS3) 21
 - 3.2.6 Special Function Registers (SFR) 22
 - 3.3 PROGRAM COUNTER (PC) 23
 - 3.4 PROGRAM STATUS WORDS (PSW) 23
 - 3.5 MEMORY SPACE 24
 - 3.5.1 Basic Memory Space 24
 - 3.5.2 Extended Memory Space 25
 - 3.5.3 Special Function Register Area 26
 - 3.5.4 Vector Table Area 34
 - 3.6 REGISTER FILE SPACE 36
 - 3.7 I/O SPACE 38

- 4. BUS CONTROL FUNCTIONS 39
 - 4.1 WAIT FUNCTION 39
 - 4.2 REFRESH FUNCTION 41
 - 4.2.1 Refresh Mode Register (RFM) 41
 - 4.2.2 Wait Control in Refresh Cycle 41
 - 4.2.3 Refresh Address 41

- 5. INTERRUPT FUNCTIONS 42**
 - 5.1 FEATURES 42
 - 5.2 INTERRUPT RESPONSE METHODS 45
 - 5.2.1 Vectored Interrupts 45
 - 5.2.2 Register Bank Switching Function 46
 - 5.2.3 Macro Service Function 47

- 6. DMA FUNCTION (DMA CONTROLLER) 48**
 - 6.1 FEATURES 48

- 7. SERIAL INTERFACE FUNCTIONS 50**
 - 7.1 FEATURES 50
 - 7.2 PROTOCOLS 50
 - 7.3 UART 51
 - 7.3.1 Features 51
 - 7.4 CLOCKED SERIAL INTERFACE (CSI) 52
 - 7.4.1 Features 52

- 8. PARALLEL INTERFACE FUNCTIONS 53**
 - 8.1 FEATURES 53

- 9. TIMER FUNCTION 55**
 - 9.1 FEATURES 55
 - 9.2 TIMER UNIT CONFIGURATION 55
 - 9.3 REAL-TIME OUTPUT PORT FUNCTION 57
 - 9.3.1 Real-Time Output Port Configuration 57
 - 9.3.2 Real-Time Output Port Operation 59

- 10. PWM UNIT 61**
 - 10.1 FEATURES 61
 - 10.2 PWM UNIT CONFIGURATION 61

- 11. WATCHDOG TIMER FUNCTION 63**
 - 11.1 FEATURES 63
 - 11.2 WATCHDOG TIMER CONFIGURATION AND OPERATION 63

- 12. A/D CONVERTER FUNCTION 64**
 - 12.1 FEATURES 64

- 13. STANDBY FUNCTION 66**
 - 13.1 HALT MODE 66
 - 13.2 STOP MODE 67

- 14. CLOCK GENERATOR 68**
 - 14.1 CLOCK GENERATOR CONFIGURATION AND OPERATION 68

15. SOFTWARE INTERVAL TIMER FUNCTION 70
 15.1 SOFTWARE INTERVAL TIMER CONFIGURATION 70

16. CODEC INSTRUCTION 71
 16.1 FEATURES 71
 16.2 MEMORY MAP 74
 16.3 PROCESSING FLOW 76

17. INSTRUCTION SET 78
 17.1 INSTRUCTIONS NEWLY ADDED TO V20/V30 AND V25/V35 78
 17.2 INSTRUCTION SET OPERATIONS 80
 17.3 INSTRUCTION SET TABLE 105

18. ELECTRICAL SPECIFICATIONS 128

19. CHARACTERISTIC CURVES (FOR REFERENCE ONLY) 158

20. PACKAGE DRAWINGS 159

21. RECOMMENDED SOLDERING CONDITIONS 162

1. PIN FUNCTIONS

1.1 LIST OF PIN FUNCTIONS

1.1.1 Port Pins

Pin Name	Input/Output	Function	Alternate Function	
P00 to P07	Input/output	Port 0 Input/output specifiable bit-wise 8-bit input/output port	—	
P10*	Input	Port 1 7-bit input port	NMI	
P11			INTP0	
P12			INTP1	
P13			INTP2	
P14			INTP3/TI	
P15			INTP4	
P16			INTP5	
P20	Input/output	Port 2 Input/output specifiable bit-wise 6-bit input/output port	PWM	
P21			TO00	
P22			TO01	
P23			TO20	
P24			TO21	
P25			TO30	
P30		Port 3 Input/output specifiable bit-wise 7-bit input/output port	Port 3 Input/output specifiable bit-wise 7-bit input/output port	TxD0/SB0/SO0
P31				RxD0/SB1/SI0
P32				TxC/SCK0
P33				CTS0
P34				TxD1/SO1
P35				RxD1/SI1
P36				CTS1/SCK1
P40 to P47				Port 4 Input/output specifiable bit-wise 8-bit input/output port
P50	Port 5 Input/output specifiable bit-wise 3-bit input/output port	DATA $\overline{\text{STB}}$		
P51		ACK		
P52		BUSY		
P60 to P63	Input	Port 6 Input/output specifiable bit-wise 4-bit input/output port	ANI0 to ANI3	
P70 to P77	Input/output	Port 7 Input/output specifiable bit-wise 8-bit input/output port	RTP0 to RTP7	
P80		Port 8 Input/output specifiable bit-wise 2-bit input/output port	DMARQ0	
P81			DMARQ1	

* Unusable as general-purpose port (non-maskable interrupt)

1.1.2 Non-Port Pins

(1) Bus control pins

Pin Name	Input/ Output	Function	Alternate Function
$\overline{\text{ASTB}}$	Output	External bus cycle address strobe signal output in external bus	—
$\overline{\text{RD}}$		External memory cycle data read strobe signal output in external bus	
$\overline{\text{WRL}}$		External memory cycle lower byte data write strobe signal output in external bus	
$\overline{\text{WRH}}$		External memory cycle upper byte data write strobe signal output in external bus	
READY	Input	External bus cycle ready signal input in external bus	
$\overline{\text{DEX}}$	Output	External bus cycle upper byte data enable signal output	
$\overline{\text{RAS}}$		DRAM low address latch timing signal output	
D8/D16	Input	External bus data bus width selection signal input	
$\overline{\text{BUSLOCK}}$	Output	External bus bus lock signal output	
$\overline{\text{POLL}}$	Input	Input of $\overline{\text{POLL}}$ signal (sampled in POLL instruction execution)	
HLDRQ		External bus hold request signal input	
$\overline{\text{HLDACK}}$	Output	External bus hold acknowledge signal output	
$\overline{\text{REFRQ}}$		Refresh pulse signal output	
AD0 to AD15	3-state input/output	External bus cycle address/data multiplex signal input/output in external bus	
A16 to A23	3-state output	External bus cycle address signal output in external bus	
$\overline{\text{IORD}}$	Output	External I/O cycle data read strobe signal output	
$\overline{\text{IOWR}}$		External I/O cycle data write strobe signal output	
DMARQ0	Input	DMA request signal input (channel 0)	P80
DMARQ1		DMA request signal input (channel 1)	P81
$\overline{\text{DMAACK0}}$	Output	DMA acknowledge signal output (channel 0)	—
$\overline{\text{DMAACK1}}$		DMA acknowledge signal output (channel 1)	
$\overline{\text{TCE0}}$		DMA termination signal output (channel 0)	
$\overline{\text{TCE1}}$		DMA termination signal output (channel 1)	

(2) Other pins

Pin Name	Input/Output	Function	Alternate Function
GND	—	GND potential	—
V _{DD}		Positive power supply	
AV _{SS}		A/D converter GND potential	
AV _{DD}		A/D converter analog power supply	
AV _{REF}	Input	A/D converter reference voltage input	
RESET		System reset signal input	
X1		Connection pins of crystal resonator/ceramic resonator for system clock generation. In case of external clock supply, input to X1 and leave X2 open.	
X2			
CLKOUT	Output	Internal system clock ϕ output	
WDTOUT		Watchdog timer overflow signal output	
NMI	Input	Non-maskable interrupt request input *1	P10
INTP0		External interrupt request input *2	P11
INTP1			P12
INTP2			P13
INTP3			P14/TI
INTP4			P15
INTP5			P16
TI		External event clock input	P14/INTP3
PWM	Output	PWM output	P20
TO00, TO01, TO20, TO21, TO30		Timer unit output	P21 to P25
TxD0		UART transmission data output	P30/SB0/SO0
RxD0	Input	UART reception data input	P31/SB1/SI0
TxC	Output	UART transmission clock output	P32/SCK0
CTS0	Input	UART transmission enable signal input	P33
CTS1			P36/SCK1
SB0	Input/output	SBI transmission/reception data input/output	P30/TxD0/SO0
SB1			P31/RxD0/SI0

- * 1. Because NMI interrupt is unmaskable, NMI interrupt is always initiated by detecting a valid edge (when reading from port 1, the pin level is read).
2. By masking or disabling (IE = 0) these interrupts, these pins can be used as general-purpose input/output ports, respectively.

Pin Name	Input/ Output	Function	Alternate Function
SO0	Output	CSI transmission data output	P30/TxD0/SB0
SO1			P34/TxD1
SI0	Input	CSI reception data input	P31/RxD0/SB1
SI1			P35/RxD1
$\overline{\text{SCK0}}$	Input/output	CSI serial clock input/output	P32/TxC
SCK1			P36/CTS1
PD0 to PD7		Parallel interface — Data input/output	P40 to P47
$\overline{\text{DATASTB}}$		Parallel interface — Data strobe signal	P50
$\overline{\text{ACK}}$		Parallel interface — Acknowledge signal	P51
BUSY		Parallel interface — Busy signal	P52
ANI0 to ANI3	Input	Analog input signal to A/D converter	P60 to P63
RTP0 to RTP7	Output	Real-time output port	P70 to P77

2. BLOCK CONFIGURATION

2.1 BUS CONTROL UNIT (BCU)

The BCU performs control of the main bus. The BCU starts the necessary internal/external bus cycle on the basis of the physical address obtained from the execution unit (EXU).

2.2 EXECUTION UNIT (EXU)

The EXU controls address calculation, arithmetic and logical operations, data transfer, etc., by means of a microprogram (firmware for controlling the microsequencer on the basis of decoded op code). The EXU contains 512 bytes of RAM (corresponding to the register file space).

2.3 INTERRUPT CONTROLLER (INTC)

The INTC services hardware interrupt requests generated by on-chip peripheral hardware and interrupt requests generated externally with vectored interrupts, bank switching, or macro service. It can also control the programmable 4-level interrupt priority order, and can also perform multiprocessing control for interrupt.

2.4 DMA CONTROLLER (DMAC)

The DMAC is a general-purpose DMA controller, capable of handling the 16M-byte memory space in a linear fashion. Operating modes comprise memory-to-memory transfer mode, intelligent DMA (ring buffer method and counter control method) mode, next address specification mode, and 2-channel operation.

2.5 UART/CLOCKED SERIAL INTERFACE (UART/CSI)

This block supports the asynchronous interface (UART) in which data synchronization is achieved by means of start/stop bits, and the clocked serial interface (CSI), allowing either to be used.

For the clocked serial interface there is a further choice of serial bus interface mode (SBI) or 3-wire serial I/O mode.

2.6 PARALLEL INTERFACE UNIT (PIU)

This performs input/output using strobe signal synchronization in 8-bit units, and supports the Centronics interface and general-purpose parallel data communication functions.

2.7 A/D CONVERTER UNIT (8-BIT A/D)

This is an A/D converter with 4 analog inputs, and provided with 4 A/D conversion result registers.

2.8 TIMER/COUNTER UNIT (TCU)

The timer/counter unit incorporates a 16-bit timer/counter, and can be used as an interval timer, free-running counter, or event counter.

2.9 PWM (PULSE WIDTH MODULATION) UNIT (PWM)

An 8-bit precision PWM (pulse width modulation) signal output function.

2.10 WATCHDOG TIMER (WDT)

The WDT incorporates an 8-bit watchdog timer for detection of inadvertent program looping, system errors, etc. The $\overline{\text{WDTOUT}}$ pin is provided to give external notification of the generation of watchdog timer interrupts.

2.11 PORTS (PORT)

53 port pins are provided, allowing port pin and control pin functions to be selected.

2.12 REAL-TIME OUTPUT PORT (RTOP)

This is a real-time output port which uses an interrupt from timer 0 as a trigger. It can output the contents of the 8-bit buffer register at programmable intervals in 4-bit or 8-bit units.

2.13 CLOCK GENERATOR (CG)

The CG generates a clock at a frequency of 1/2, 1/4, 1/8 or 1/16 that of the crystal and oscillator connected to the X1 and X2 pins and supplies it as the CPU operating clock.

2.14 SOFTWARE INTERVAL TIMER (SIT)

The SIT incorporates a 16-bit software interval timer as a software timer function and watch function timer. Interval interrupts can be set by input clock (count clock) selection and software timer/counter compare register setting.

3. CPU FUNCTIONS

The CPU of the V55PI is software upward compatible with the V20 and V30 (native mode), and the V25 and V35.

3.1 FEATURES

- Software upward compatible with V20 & V30 (native mode) and V25 & V35 (includes additional instructions)
- Minimum instruction cycle: 160 ns/12.5 MHz (external 25 MHz clock)
125 ns/16 MHz (external 32 MHz clock)
- Address space: 16M bytes
 - 1M-byte basic memory (program) space
 - 16M-byte extended memory (data) space
- Register file space (in on-chip RAM): 512 bytes/16 register banks
- I/O space: 64K bytes
- Register configuration (compared with V20/V30 and V25/V35)

Item		V20, V30	V25, V35	V55PI
Extended segment register		None	None	DS2, DS3
Register bank		None	8 banks (in memory space)	16 banks (in register file space)
PSW	Mode flag	MD	None	None
	Register bank flags	None	RB0 to RB2	RB0 to RB3
	Input/output instruction trap flag	None	$\overline{\text{IBRK}}$	$\overline{\text{IBRK}}$
	User flag	None	F0, F1	None
Special function register area		None	240 bytes (memory mapping onto FFF00H to FFFE0H)	496 bytes (memory mapping onto FFE00H to FFEFH)

- Internal 16-bit architecture, switchable external data bus width (16/8 bits)
- Automatic wait control with memory divided in variable sizes (max. 6 blocks)
 - Programmable wait function
 - Wait function using READY pin
- Refresh function
 - Automatic generation of refresh cycle (RAS only)
- $\overline{\text{RAS}}$ pin functions
 - $\overline{\text{RAS}}$ pin → DRAM RAS timing
 - $\overline{\text{RD}}, \overline{\text{WRH}}, \overline{\text{WRL}}$ pins → DRAM CAS timing
 - $\overline{\text{ASTB}}$ pin → DRAM row/column address switching timing

3.2 REGISTERS

The V55PI CPU has general register sets compatible with the V20 and V30 (native mode), and the V25 and V35. The general register sets are mapped onto the register file space. These general register sets are also used as on-chip RAM, and there can be a maximum of 16 register sets in bank form.

In addition, the V55PI has various special function registers for controlling on-chip peripheral hardware. These special function registers are mapped onto memory space addresses 0FFE00H to 0FFFEFH.

3.2.1 Register Banks

The general register sets are mapped onto the register file space (in on-chip RAM). The general register sets are used in a bank arrangement; each bank consists of 32 bytes and up to 16 banks can be set.

The CPU normally uses register bank 15 for program execution, and it is possible to switch to another bank automatically by means of maskable hardware interrupt or software interrupt (BRKCS instruction). It is possible to return from the switched-to register bank to the original register bank by means of the instruction for returning from an interrupt (RETRBI).

The register bank configuration is shown in Figure 3-1. The general register sets are mapped onto the area with an offset of (+08H) to (+1FH) from the start address of each register bank. The word address from the start in a register bank is the extended segment register (DS2) area. The vector PC/DS3 area is used to set the value to be loaded into the PC when the register bank is switched, that is, the offset value of the start address of the interrupt service routine. This area is also used as the extended segment register (DS3) area. The PSW save area is used to save the PSW when the register bank is switched, and the PC save area is used to save the PC when the register bank is switched.

After a reset, register bank 15 is selected automatically. Also, segment register initialization after a reset is performed for register bank 15 only.

The register file space onto which these general register sets are mapped can also be accessed as data memory by addition of a special prefix instruction (IRAM:) to a memory manipulation instruction.

Of the 16 set register banks, banks 0 and 1 have macro service channels (parameter and work area for macro service) allocated in duplicate.

Figure 3-1. Register Bank Configuration

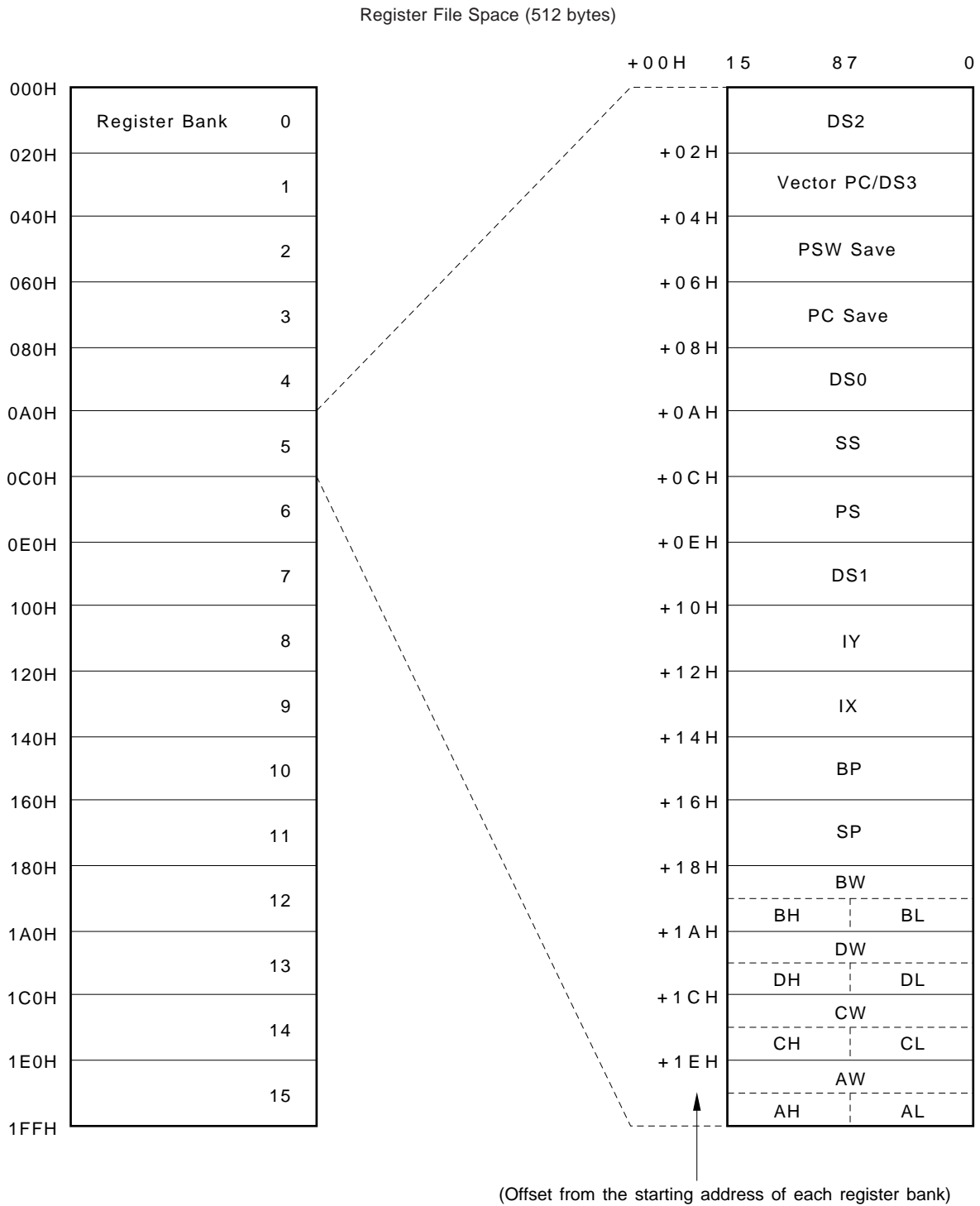

3.2.2 General Registers (AW, BW, CW, DW)

There are four 16-bit general registers. In addition to being accessed as 16-bit registers, these registers can also be accessed as 8-bit registers by dividing each register into upper and lower 8-bit halves (AH, AL, BH, BL, CH, CL, DH, DL).

These registers are used as 8-bit or 16-bit registers with a wide range of instructions including transfer, arithmetic and logical operation instructions.

Each register is also used as the default register for specific instruction processing, as shown below.

- AW : Word multiplication/division, word input/output, data conversion
- AL : Byte multiplication/division, byte input/output, BCD rotation, data conversion
- AH : Byte multiplication/division
- BW : Data conversion
- CW : Loop control branch, repeat prefix
- CL : Shift instructions, rotate instructions, BCD operations
- DW : Word multiplication/division, indirect addressing input/output

These registers are mapped onto the register file space (in on-chip RAM). The address is the value obtained by adding the offset for each register to (register bank number × 32).

Table 3-1. General Register Offsets

Register	Offset	Register	Offset
AW	1EH	AL	1EH
		AH	1FH
BW	18H	BL	18H
		BH	19H
CW	1CH	CL	1CH
		CH	1DH
DW	1AH	DL	1AH
		DH	1BH

3.2.3 Pointers (SP, BP) and Index Registers (IX, IY)

These are 16-bit registers used as base pointers or index registers in memory accesses using based addressing (BP), indexed addressing (IX, IY), based indexed addressing (BP, IX, IY), etc. The SP is also used as the pointer in stack operations. As with general registers, these are used with transfer instructions, arithmetic operation instructions, etc., but in this case they cannot be used as 8-bit registers. Each register is also used as the fixed address pointer for specific instruction processing, as shown below.

- SP : Stack manipulation
- IX : Block transfers, BCD operation source side address specification
- IY : Block transfers, BCD operation destination side address specification

These registers are mapped onto the register file space (in on-chip RAM). The address is the value obtained by adding the offset for each register to (register bank number × 32).

Table 3-2. Pointer and Index Register Offsets

Register	Offset
SP	16H
BP	14H
IX	12H
IY	10H

3.2.4 Segment Registers (PS, SS, DS0, DS1)

The CPU manages the 1M-byte basic memory space by dividing it into 64K-byte units. The CPU specifies the start address of each segment with a segment register, and uses another register or effective address for the specification of physical address, with the relative address from the start address as the offset.

The physical address is created as shown below.

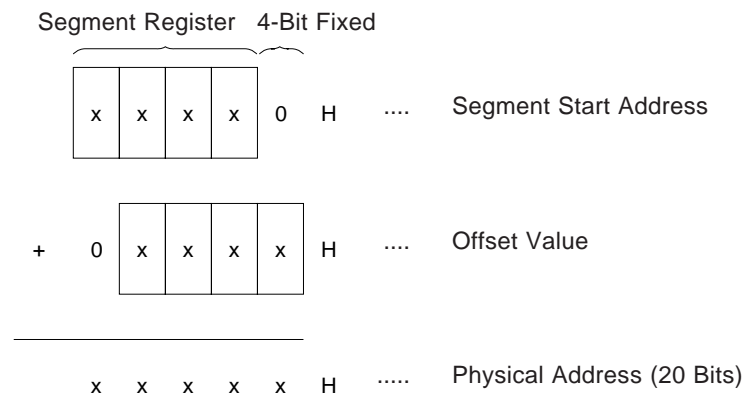

There are four segment registers: PS (Program Segment), SS (Stack Segment), DS0 (Data Segment 0), and DS1 (Data Segment 1). The respective segments are used in the following cases.

- PS : Program fetch
- SS : Stack manipulation instructions, addressing using BP as base register
- DS0 : General variable accesses, source block data accesses such as block transfer instructions, etc.
- DS1 : Destination block data accesses such as block transfer instructions, etc.

However, using a segment override prefix instruction makes it possible for access of general variables to change from DS0 to another segment register. Also, in addressing which uses BP as the base register, another segment register can be used instead of SS.

Example MOV AW, 1000H
 MOV DS1 : AW
 MOV BL, DS1, BYTE PTR [IX]; DSI : Byte data read from IX

When a reset is performed, PS of register bank 15 is initialized to FFFFH, and SS, DS0 and DS1 are initialized to 0000H.

These registers are mapped onto the register file space (in on-chip RAM). The address is the value obtained by adding the offset for each register to (register bank number × 32).

Table 3-3. Segment Register Offsets

Register	Offset
DS0	08H
DS1	0EH
SS	0AH
PS	0CH

3.2.5 Extended Segment Registers (DS2, DS3)

In addition to the segment registers for accessing the 1M-byte basic memory space, the V55PI is provided with extended segment registers which specify the start address of each 64K-byte segment of the 16M-byte extended memory space. There are two extended segment registers, DS2 (Data Segment 2) and DS3 (Data Segment 3), which are used as shown below.

DS2: Extended memory space general variable accesses (by segment override prefix instructions), source block data accesses in extended memory space block transfer instructions, etc.

DS3: Extended memory space general variable accesses (by segment override prefix instructions), destination block data accesses in extended memory space block transfer instructions, etc.

The data access using an extended segment register is performed by using the segment override prefix. Especially, in the block transfer instruction, DS2 and DS3 can be specified simultaneously by segment override prefix. (In this case, the order for DS2 and DS3 is optional.)

Example REP
 DS2:
 DS3: MOVBKW ; Word memory block transfer from DS2 : IX to DS3 : IY.

The CPU specifies the start address of each segment with an extended segment register, and performs an access by using another register or effective address for the specification of physical address, with the relative address from the start address as the offset value.

The physical address is created as shown in the next page.

Extended Segment Register 8-Bit Fixed

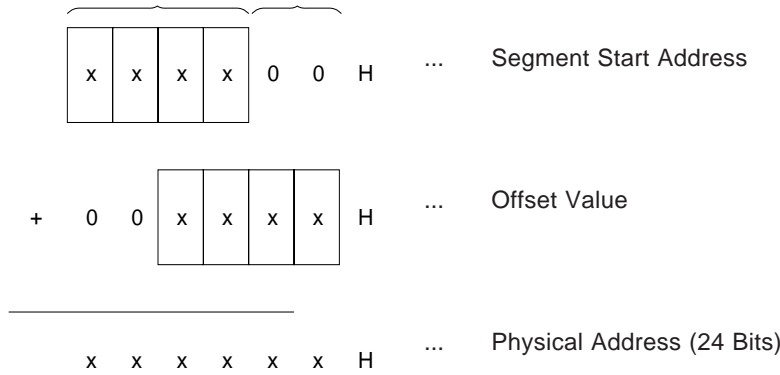

When a reset is performed, DS2 and DS3 of register bank 15 are initialized to 0000H. These registers are mapped onto the register file space (in on-chip RAM). The address is the value obtained by adding the offset for each register to (register bank number × 32).

Table 3-4. Extended Segment Register Offsets

Register	Offset
DS2	00H
DS3	02H (Also used as vectored PC)

3.2.6 Special Function Registers (SFR)

The V55PI has a group of registers with the function of controlling on-chip peripheral hardware.

A number of registers are provided according to the type of control for each peripheral hardware unit, and the actual operation can be set using the individual bits in the registers. These registers are mapped onto the memory space, and are read and written to using the same method as for ordinary memory (see 3.5.3 "Special Function Register Area").

```

Example  MOV  AW, 0FFE0H
           MOV  DS1, AW
           MOV  BL, DS1 : BYTE PTR [1EFH]; 0FFE0H : 1EFH (PRC register) Read
    
```

There are also two instructions, BTCLR and BTCLRL, which are only valid for special function registers. Of these, BTCLRL is an instruction newly provided in the V25 or V35.

The BTCLR instruction is valid for registers in the upper 240 bytes (0FFF00H to 0FFFEFH) of the special function register area, and the BTCLRL instruction is valid for registers in the lower 256 bytes (0FFE00H to 0FFFEFH).

3.3 PROGRAM COUNTER (PC)

This is a 16-bit binary counter which holds the offset value of the program memory address on which the CPU is to perform execution.

The PC is incremented each time an instruction code is fetched from the instruction queue, and is also loaded with the new location address value when a branch, call, return or break instruction is executed.

When a reset is performed, 0000H is loaded into the PC. Because the PS register is initialized to FFFFH in a reset, after a reset the CPU begins execution at physical address 0FFFF0H.

3.4 PROGRAM STATUS WORDS (PSW)

The PSW consists of 6 status flags and 5 control flags.

• Status flags

- V (Overflow) ...Overflow detection flag
- S (Sign) ...Sign bit detection flag
- Z (Zero) ...All zero detection flag
- AC (Auxiliary Carry) ...4-bit carry/borrow detection flag
- P (Parity) ...Parity detection flag
- CY (Carry) ...Carry/borrow detection flag

• Control flags

- RB0 to RB3 (Register Banks 0 to 3) ...Register bankspecification flags
- DIR (Direction) ...Block transfer/input/output instruction direction control flag
- IE (Interrupt Enable) ...Interrupt enabled state control flag
- BRK (Break) ...Single-step interrupt control flag
- $\overline{\text{IBRK}}$ (I/O Break) ...Input/output instruction trap control flag

The status flags are set (1) or reset (0) automatically according to the result (data value) of execution of various kinds of instructions. The CY flag can be directly set, reset or inverted by an instruction.

The control flags are set or reset by instructions, and control the operation of the CPU. The IE and BRK flags are always reset when interrupt servicing is initiated.

The contents of the PSW can be saved to and restored from the stack by the PUSH and POP instructions. However, when the contents are restored by the POP PSW instruction, bits 12 to 15 (RB0 to RB3) are not returned to the PSW.

The low-order 8 bits of the PSW can also be saved to or restored from the AH register by an MOV instruction.

The PSW bit configuration is shown below.

15	14	13	12	11	10	9	8	7	6	5	4	3	2	1	0
RB3	RB2	RB1	RB0	Y	DIR	IE	BRK	S	Z	0	AC	0	P	$\overline{\text{IBRK}}$	CY

3.5 MEMORY SPACE

The V55PI has a 16M-byte memory space. Of this, using lowest 1M bytes (000000H to 0FFFFFFH) as the basic memory space, the 16M bytes including the basic memory space (000000H to FFFFFFFH) can be accessed as the extended memory space. The basic memory space can be accessed using the segment registers (PS, SS, DS0, DS1) in the same way as in the V25 and V35. The extended memory space can be accessed using the extended segment registers (DS2, DS3), and has the basic memory space mapped onto the lowest 1M bytes. See **3.2.4 "Segment Registers (PS, SS, DS0, DS1)"** and **3.2.5 "Extended Segment Registers (DS2, DS3)"** for the physical addresses.

The 496-byte space 0FFE00H to 0FFFEFH has mapped onto it a group of registers to which specific functions are allocated such as on-chip peripheral hardware registers, control registers, etc., and these are manipulated by memory accesses.

In addition, independent of these, there is a 512-byte register file space (in on-chip RAM). In addition to being accessed by using register manipulation instructions as in the V25 and V35, the register file space can also be accessed as data memory by adding a special prefix instruction (IRAM:) to a memory manipulation in.

Figure 3-2. Memory Space

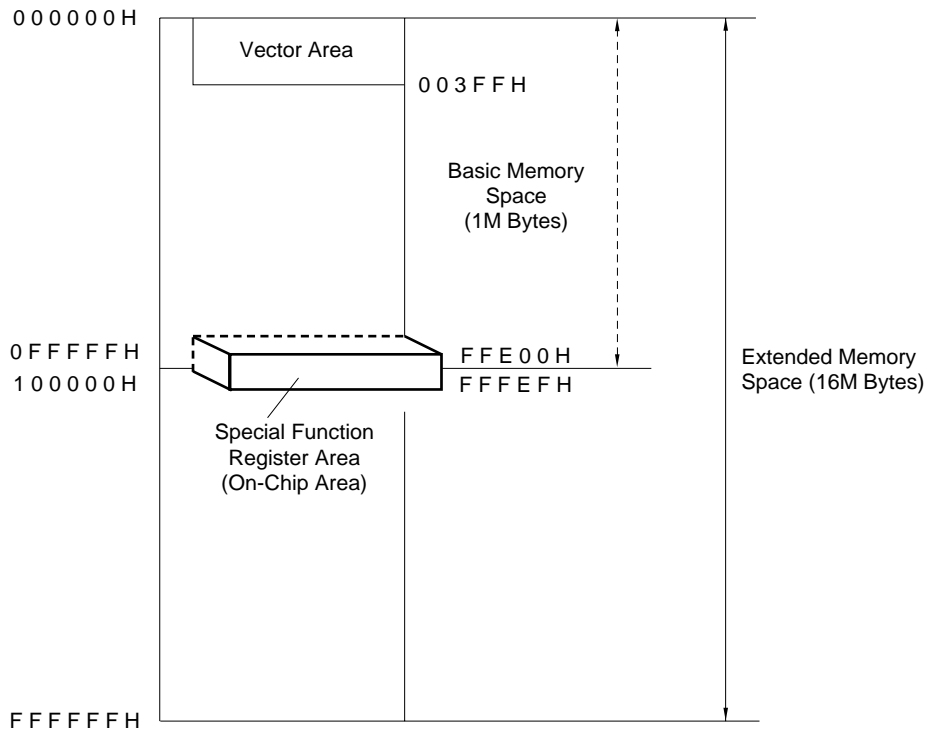

3.5.1 Basic Memory Space

The memory space comprises a 1M-byte basic memory space and 16M-byte extended memory space. The basic memory space is mapped onto the lowest 1M bytes (000000H to 0FFFFFFH) of the extended memory space.

The 1M-byte basic memory space is shown in Figure 3-3.

Conditions for accessing the basic memory space by software are the same as for the V20/V30 and V25/V35.

A basic memory space physical address is specified by the segment start address indicated by the segment register (PS, SS, DS0, DS1) and the offset value from the segment start position indicated by another register or immediate data.

The basic memory space has the vectored interrupt vector area and special function register area mapped onto it. For an area in which special function registers are mapped, data accesses cannot be made to external memory (program fetches are possible.)

Figure 3-3. Basic Memory Space

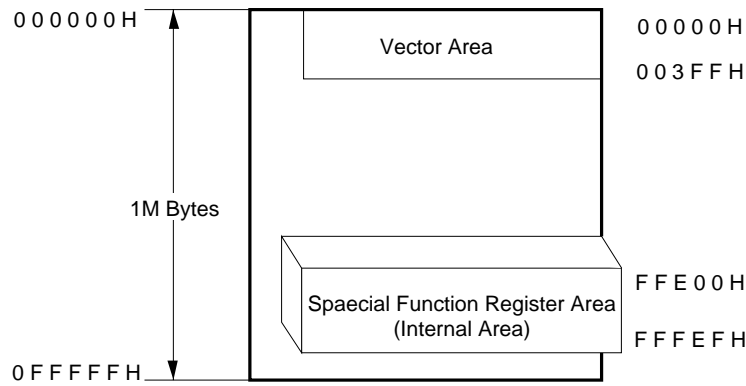

0FFF0H to 0FFFFFFH is a program area used for the system boot, and PS and PC become 0FFFH and 0H, respectively, therefore the program execution starts from 0FFF0H.

3.5.2 Extended Memory Space

The 16M-byte extended memory space is shown in Figure 3-4.

The only accesses that can be performed on the extended memory space are data accesses.

The basic memory space is mapped onto the lowest 1M bytes (000000H to 0FFFFFFH) of the extended memory space, and can be accessed using the segment registers PS, SS, DS0 and DS1.

Data accesses can be performed in the extended memory space using the extended segment registers DS2 and DS3. With DS2 and DS3 it is possible to use a specification as a segment override prefix instruction added to a memory manipulation instruction.

An extended memory space physical address is specified by the segment start address indicated by the extended segment register and the offset value from the segment start position indicated by another register or immediate data. If the generated address indicates the lowest 1M-byte area (000000H to 0FFFFFFH), the basic memory space is accessed.

Figure 3-4. Extended Memory Space

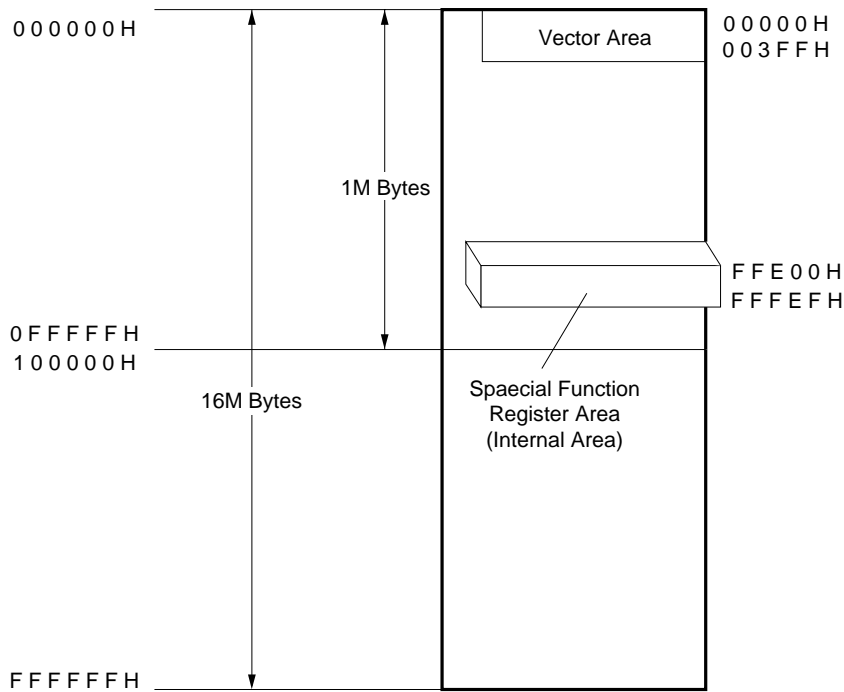

3.5.3 Special Function Register Area

The 496-byte space 0FFE00H to 0FFFEFH has mapped onto it a group of registers to which functions such as on-chip peripheral hardware operation specification, status monitoring, etc., are assigned.

Program fetches cannot be performed from these areas.

Special function register manipulation is performed by accesses by means of memory manipulation instructions.

If the special function register area is accessed, RD, WRH, WRL, IORD, IOWR and other control signals do not become active.

A list of special function registers is given in Table 3-5. The meaning of the items in the table is explained below.

- Symbol..... The symbol used to indicate the special function register name. Corresponds to the operand description format (symbol name) in a memory manipulation instruction.
- R/W Indicates whether this special function register is read/write enabled.
 - R/W : Read/write enabled
 - R : Read only
 - W : Write only
- Manipulation Method Indicates which of the following can be used on the register: bit manipulation, 8-bit manipulation, 16-bit manipulation, 32-bit manipulation.
- RESET Indicates the status of the register after RESET input.

Note Addresses which are not listed are the reserved area, therefore, they should not be accessed by the user program.

Table 3-5. Special Function Registers (1/7)

Address	Special Function Register Name	Symbol	R/W	Manipulable Bit Units				After Reset
				1 Bit	8 Bits	16 Bits	32 Bits	
0FFE00H	A/D conversion result register 0	ADCR0	R		●			Undefined
0FFE02H	A/D conversion result register 1	ADCR1	R		●			Undefined
0FFE04H	A/D conversion result register 2	ADCR2	R		●			Undefined
0FFE06H	A/D conversion result register 3	ADCR3	R		●			Undefined
0FFE10H	Parallel interface buffer	PAD	R/W *1		●			Undefined
0FFE18H	Parallel interface control register 0	PAC0	R/W	●	●			90H
0FFE19H	Parallel interface control register 1	PAC1	R/W	●	●			03H
0FFE1AH	Parallel interface status register	PAS	R/W *2		●			40H
0FFE1CH	Parallel interface acknowledge interval register 1	PAI1	W		●			Undefined
0FFE1DH	Parallel interface acknowledge interval register 2	PAI2	W		●			Undefined
0FFE20H	A/D converter mode register	ADM	R/W	●	●			00H
0FFEC0H	Interrupt mask flag register 0 (low)	MK0	MK0L	R/W	●	●	●	FFH
0FFEC1H	Interrupt mask flag register 0 (high)		MK0H	R/W	●	●		FFH
0FFEC2H	Interrupt mask flag register 1 (low)	MK1	MK1L	R/W	●	●	●	FFH
0FFEC3H	Interrupt mask flag register 1 (high)		MK1H	R/W	●	●		FFH
0FFEC4H	In-service priority register	ISPR	R	●	●			00H
0FFEC5H	Interrupt mode control register	IMC	R/W		●			80H
0FFEC9H	Interrupt request control register 09	IC09	R/W	●	●			43H
0FFECAH	Interrupt request control register 10	IC10	R/W	●	●			43H
0FFECBH	Interrupt request control register 11	IC11	R/W	●	●			43H
0FFECCH	Interrupt request control register 12	IC12	R/W	●	●			43H
0FFECDH	Interrupt request control register 13	IC13	R/W	●	●			43H

* 1. Varies according to input/output mode.
 2. Some bits R, others R/W (possible).

Table 3-5. Special Function Registers (2/7)

Address	Special Function Register Name	Symbol	R/W	Manipulable Bit Units				After Reset
				1 Bit	8 Bits	16 Bits	32 Bits	
0FFECEH	Interrupt request control register 14	IC14	R/W	●	●			43H
0FFED0H	Interrupt request control register 16	IC16	R/W	●	●			43H
0FFED1H	Interrupt request control register 17	IC17	R/W	●	●			43H
0FFED2H	Interrupt request control register 18	IC18	R/W	●	●			43H
0FFED3H	Interrupt request control register 19	IC19	R/W	●	●			43H
0FFED4H	Interrupt request control register 20	IC20	R/W	●	●			43H
0FFED5H	Interrupt request control register 21	IC21	R/W	●	●			43H
0FFED6H	Interrupt request control register 22	IC22	R/W	●	●			43H
0FFED7H	Interrupt request control register 23	IC23	R/W	●	●			43H
0FFED8H	Interrupt request control register 24	IC24	R/W	●	●			43H
0FFED9H	Interrupt request control register 25	IC25	R/W	●	●			43H
0FFEDA H	Interrupt request control register 26	IC26	R/W	●	●			43H
0FFEDB H	Interrupt request control register 27	IC27	R/W	●	●			43H
0FFEDC H	Interrupt request control register 28	IC28	R/W	●	●			43H
0FFEDD H	Interrupt request control register 29	IC29	R/W	●	●			43H
0FFEDE H	Interrupt request control register 30	IC30	R/W	●	●			43H
0FFEDF H	Interrupt request control register 31	IC31	R/W	●	●			43H
0FFEE0 H	Interrupt request control register 32	IC32	R/W	●	●			43H
0FFEE4 H	Interrupt request control register 36	IC36	R/W	●	●			43H
0FFEE5 H	Interrupt request control register 37	IC37	R/W	●	●			43H
0FFF00 H	Port 0	P0	R/W	●	●			Undefined
0FFF01 H	Port 1	P1	R	●	●			Undefined
0FFF02 H	Port 2	P2	R/W	●	●			Undefined
0FFF03 H	Port 3	P3	R/W	●	●			Undefined

Table 3–5. Special Function Registers (3/7)

Address	Special Function Register Name	Symbol	R/W	Manipulable Bit Units				After Reset
				1 Bit	8 Bits	16 Bits	32 Bits	
0FFF04H	Port 4	P4	R/W	●	●			Undefined
0FFF05H	Port 5	P5	R/W	●	●			Undefined
0FFF06H	Port 6	P6	R	●	●			Undefined
0FFF07H	Port 7	P7	R/W	●	●			Undefined
0FFF08H	Port 8	P8	R/W	●	●			Undefined
0FFF0CH	Port read control register	PRDC	R/W	●	●			00H
0FFF0EH	Real-time output port	RTP	R/W	●	●			Undefined
0FFF10H	Port 0 mode register	PM0	R/W	●	●			FFH
0FFF12H	Port 2 mode register	PM2	R/W	●	●			FFH
0FFF13H	Port 3 mode register	PM3	R/W	●	●			FFH
0FFF14H	Port 4 mode register	PM4	R/W	●	●			FFH
0FFF15H	Port 5 mode register	PM5	R/W	●	●			FFH
0FFF17H	Port 7 mode register	PM7	R/W	●	●			FFH
0FFF18H	Port 8 mode register	PM8	R/W	●	●			FFH
0FFF22H	Port 2 mode control register	PMC2	R/W	●	●			00H
0FFF23H	Port 3 mode control register	PMC3	R/W	●	●			00H
0FFF24H	Port 4 mode control register	PMC4	R/W	●	●			00H
0FFF25H	Port 5 mode control register	PMC5	R/W	●	●			00H
0FFF27H	Port 7 mode control register	PMC7	R/W	●	●			00H
0FFF28H	Port 8 mode control register	PMC8	R/W	●	●			00H
0FFF2CH	Real-time output port control register	RTPC	R/W	●	●			40H
0FFF2DH	Real-time output port delay specification register	RTPD	R/W	●	●			Undefined
0FFF2EH	Port 7 buffer (low)	P7L	R/W	●	●			Undefined
0FFF2FH	Port 7 buffer (high)	P7H	R/W	●	●			Undefined

Table 3-5. Special Function Registers (4/7)

Address	Special Function Register Name	Symbol		R/W	Manipulable Bit Units				After Reset
					1 Bit	8 Bits	16 Bits	32 Bits	
0FFF30H	Timer control register 0	TMC0		R/W	●	●	●		00H
0FFF31H	Timer control register 1	TMC1		R/W	●	●			00H
0FFF32H	Timer output control register 0	TOC0		R/W	●	●	●		00H
0FFF33H	Timer output control register 1	TOC1		R/W	●	●			00H
0FFF34H	External interrupt mode register 0	INTM	INTM0	R/W	●	●	●		00H
0FFF35H	External interrupt mode register 1		INTM1	R/W	●	●			00H
0FFF40H	Timer register 0	TM0		R/W			●		00H
0FFF42H	Timer register 1	TM1		R/W			●		00H
0FFF44H	Timer register 2	TM2		R/W			●		00H
0FFF46H	Timer register 3	TM3		R/W			●		00H
0FFF48H	Timer capture register 00	CT00		R/W			●		Undefined
0FFF4AH	Timer capture register 01	CT01		R/W			●		Undefined
0FFF4CH	Timer compare register 00	CM00		R/W			●		Undefined
0FFF4EH	Timer compare register 01	CM01		R/W			●		Undefined
0FFF50H	Timer capture register 10	CT10		R/W			●		Undefined
0FFF52H	Timer compare register 10	CM10		R/W			●		Undefined
0FFF54H	Timer compare register 11	CM11		R/W			●		Undefined
0FFF58H	Timer compare register 20	CM20		R/W			●		Undefined
0FFF5AH	Timer compare register 21	CM21		R/W			●		Undefined
0FFF5CH	Timer compare register 22	CM22		R/W			●		Undefined
0FFF5EH	Timer compare register 23	CM23		R/W			●		Undefined
0FFF60H	Watchdog timer mode register	WDM		R/W*	●	●			00H
0FFF64H	Timer compare register 30	CM30		R/W			●		Undefined

* WDT can only be written to by the RSTWDT instruction (8-bit unit only).

Table 3-5. Special Function Registers (5/7)

Address	Special Function Register Name	Symbol	R/W	Manipulable Bit Units				After Reset
				1 Bits	8 Bits	16 Bits	32 Bits	
0FFF66H	Timer compare register 31	CM31	R/W			●		Undefined
0FFF6CH	PWM register	PWM	R/W	●	●			00H
0FFF6DH	PWM control register	PWMC	R/W	●	●			00H
0FFF70H	Transmit baud rate generator register 0	TxBRG0	R/W	●	●			Undefined
0FFF71H	Receive baud rate generator register 0	RxBRG0	R/W	●	●			Undefined
0FFF72H	Prescaler register 0	PRS0	R/W	●	●			00H
0FFF73H	UART mode register 0 / clocked serial interface mode register 0	UARTM0/CSIM0	R/W	(●)	●			00H
0FFF74H	UART status register 0 / SBI control register 0	UARTS0/SBIC0	*1/*2	(●)	●			00H
0FFF75H	UART transmit buffer 0 / clocked serial I/O shift register 0	TxB0/SIO0	W		●			Undefined
0FFF76H	Receive buffer 0	RxB0	R		●			Undefined
0FFF78H	Transmit baud rate generator register 1	TxBRG1	R/W	●	●			Undefined
0FFF79H	Receive baud rate generator register 1	RxBRG1	R/W	●	●			Undefined
0FFF7AH	Prescaler register 1	PRS1	R/W	●	●			00H
0FFF7BH	UART mode register 1 / clocked serial interface mode register 1	UARTM1/CSIM1	R/W	(●)	●			00H
0FFF7CH	UART status register 1	UARTS1	*1/*2	(●)	●			00H
0FFF7DH	UART transmit buffer 1 / clocked serial I/O shift register 1	TxB1/SIO1	W		●			Undefined
0FFF7EH	Receive buffer 1	RxB1	R		●			Undefined
0FFF7FH	Protocol selection register	ASP	R/W	●	●			00H
0FFF80H	Terminal counter 0 (low)	TC0	TC0L	R/W		●		Undefined
0FFF82H	Terminal counter 0 (high)		TC0H	R/W		●	●	Undefined

- * 1. Some bits R, others R/W.
- 2. R or W in bit units.

Remark (): Depends on the mode.

Table 3-5. Special Function Registers (6/7)

Address	Special Function Register Name	Symbol		R/W	Manipulable Bit Units				After Reset
					1 Bit	8 Bits	16 Bits	32 Bits	
0FFF84H	Terminal counter modulo register 0 (low)	TCM0	TCM0L	R/W			●	●	Undefined
0FFF86H	Terminal counter modulo register 0 (high)		TCM0H	R/W		●	●		Undefined
0FFF88H	DMA up/down counter 0 (low)	UDC0	UDC0L	R/W			●	●	Undefined
0FFF8AH	DMA up/down counter 0 (high)		UDC0H	R/W		●	●		Undefined
0FFF8CH	DMA compare register 0 (low)	DCM0	DCM0L	R/W			●	●	Undefined
0FFF8EH	DMA compare register 0 (high)		DCM0H	R/W		●	●		Undefined
0FFF90H	DMA memory address register 0 (low)	MAR0	MAR0L	R/W			●	●	Undefined
0FFF92H	DMA memory address register 0 (high)		MAR0H	R/W		●	●		Undefined
0FFF94H	DMA read/write pointer 0 (low)	DPTC0	DPTC0L	R/W			●	●	Undefined
0FFF96H	DMA read/write pointer 0 (high)		DPTC0H	R/W		●	●		Undefined
0FFF9CH	DMA mode register 0	DMAM0		R/W	●	●			E0H
0FFF9DH	DMA control register 0	DMAC0		R/W	●	●			00H
0FFF9EH	DMA status register	DMAS		R/W	●*	●			00H
0FFFA0H	Terminal counter 1 (low)	TC1	TC1L	R/W			●	●	Undefined
0FFFA2H	Terminal counter 1 (high)		TC1H	R/W		●	●		Undefined
0FFFA4H	Terminal counter modulo register 1 (low)	TCM1	TCM1L	R/W			●	●	Undefined
0FFFA6H	Terminal counter modulo register 1 (high)		TCM1H	R/W		●	●		Undefined
0FFFA8H	DMA up/down counter 1 (low)	UDC1	UDC1L	R/W			●	●	Undefined
0FFFAAH	DMA up/down counter 1 (high)		UDC1H	R/W		●	●		Undefined
0FFFACH	DMA compare register 1 (low)	DCM1	DCM1L	R/W			●	●	Undefined
0FFFAEH	DMA compare register 1 (high)		DCM1H	R/W		●	●		Undefined
0FFFB0H	DMA memory address register 1 (low)	MAR1	MAR1L	R/W			●	●	Undefined
0FFFB2H	DMA memory address register 1 (high)		MAR1H	R/W		●	●		Undefined

* Bit clear operation possible.

Table 3-5. Special Function Registers (7/7)

Address	Special Function Register Name	Symbol		R/W	Manipulable Bit Units				After Reset
					1 Bit	8 Bits	16 Bits	32 Bits	
0FFFB4H	DMA read/write pointer 1 (low)	DPTC1	DPTC1L	R/W			●	●	Undefined
0FFFB6H	DMA read/write pointer 1 (high)		DPTC1H	R/W		●	●		Undefined
0FFFBCH	DMA mode register 1	DMAM1		R/W	●	●			E0H
0FFBBDH	DMA control register 1	DMAC1		R/W	●	●			00H
0FFFE0H	Software timer/counter	STC		R			●		Undefined
0FFFE2H	Software timer/counter compare register	STMC		R/W			●		FFFFH
0FFFE8H	Programmable wait control register 0	PWC0		R/W	●	●			EAH
0FFFE9H	Programmable wait control register 1	PWC1		R/W	●	●			AAH
0FFFEAH	Memory block control register	MBC		R/W	●	●			FCH
0FFFECH	Refresh mode register	RFM		R/W	●	●			77H
0FFFEEH	Standby control register	STBC		R/W *1	●	●			Undefined *2
0FFFEFH	Processor control register	PRC		R/W	●	●			EEH

*1 The SFB bit of the standby control register can be set (1) by instruction, but cannot be cleared (0). (Only '1' can be written.)

*2 After power-on reset: 00H, otherwise: no change

3.5.4 Vector Table Area

The 1K-byte area 00000H to 003FFH in the memory space holds 256 vectors (4 bytes used per vector) for the start addresses of interrupt routines initiated by interrupt requests, break instructions, etc.

In the initial state, vectors 0 to 47 are reserved as V55PI family dedicated on-chip peripheral and software interrupt vectors. For vectors 8 to 47, the vector address of hardware interrupts except NMI can be changed by means of bits V0 and V1 of the interrupt mode control register (IMC).

Vector 0	(00000H)	: Divide error
Vector 1	(00004H)	: Single step
Vector 2	(00008H)	: NMI instruction
Vector 3	(0000CH)	: BRK 3 instruction
Vector 4	(00010H)	: BRKV instruction
Vector 5	(00014H)	: CHKIND instruction
Vector 6	(00018H)	: Input/output instruction
Vector 7	(0001CH)	: FPO instruction/exception trap

When V1 = V0 = 0 :

Vector 8	(00020H)	: INTWDT
Vector 9	(00024H)	: INTP0
Vector 10	(00028H)	: INTP1
Vector 11	(0002CH)	: INTP2
Vector 12	(00030H)	: INTP3
Vector 13	(00034H)	: INTP4
Vector 14	(00038H)	: INTP5
Vector 15	(0003CH)	: System reserved
Vector 16	(00040H)	: INTCM00
Vector 17	(00044H)	: INTCM01
Vector 18	(00048H)	: INTCM10
Vector 19	(0004CH)	: INTCM11
Vector 20	(00050H)	: INTCM21
Vector 21	(00054H)	: INTCM31
Vector 22	(00058H)	: INTD0 DMA#0_MAIN
Vector 23	(0005CH)	: INTD0S DMA#0_SUB
Vector 24	(00060H)	: INTD1 DMA#1_MAIN
Vector 25	(00064H)	: INTD1S DMA#1_SUB
Vector 26	(00068H)	: INTSER0
Vector 27	(0006CH)	: INTSER1
Vector 28	(00070H)	: INTSR0/INTCSI0
Vector 29	(00074H)	: INTSR1/INTCSI1
Vector 30	(00078H)	: INTST0
Vector 31	(0007CH)	: INTST1
Vector 32	(00080H)	: INTSIT
Vector 33	(00084H)	: System reserved
Vector 34	(00088H)	: System reserved
Vector 35	(0008CH)	: System reserved
Vector 36	(00090H)	: INTPAI
Vector 37	(00094H)	: INTAD
Vector 38	(00098H)	: System reserved
Vector 39	(0009CH)	: System reserved

Vector 40 (000A0H) : System reserved
 Vector 41 (000A4H) : System reserved
 Vector 42 (000A8H) : System reserved
 Vector 43 (000ACH) : System reserved
 Vector 44 (000B0H) : System reserved
 Vector 45 (000B4H) : System reserved
 Vector 46 (000B8H) : System reserved
 Vector 47 (000BCH) : System reserved

When V1 = 0, V0 = 1 :

Vector 72 (00120H) : INTWDT
 Vector 73 (00124H) : INTPO
 : : :
 : : :
 : : :
 Vector 110 (001B8H) : System reserved
 Vector 111 (001BCH) : System reserved

When V1 = 1, V0 = 0 :

Vector 136 (00220H) : INTWDT
 Vector 137 (00224H) : INTPO
 : : :
 : : :
 : : :
 Vector 174 (002B8H) : System reserved
 Vector 175 (002BCH) : System reserved

When V1 = 1, V0 = 1 :

Vector 200 (00320H) : INTWDT
 Vector 201 (00324H) : INTPO
 : : :
 : : :
 : : :
 Vector 238 (003B8H) : System reserved
 Vector 239 (003BCH) : System reserved

3.6 REGISTER FILE SPACE

The register file space is shown in Figure 3-5.

The size of the register file space is 512 bytes, and a maximum 16-bank register set can be set.

The register file space is separate from the memory space, and in addition to accesses using a register manipulation instruction as with the V25 and V35, the register file space can be accessed as data memory by adding a special prefix instruction (IRAM:) to a memory manipulation instruction. (Access is performed asynchronously independently of the external bus cycle.

When the IRAM: prefix instruction is added to a memory manipulation instruction, the CPU performs a data access with the low-order 9 bits of the memory address offset value as the register file address. In this case, segment register and physical address addition is not performed, and an external bus cycle is not initiated.

Example

```
Label1: MOV  IRAM : [0024H], AW  .... <1>
        MOV  [0056H], BW       .... <2>
```

<1> This shows the case where data is transferred to the register file space using an "IRAM:" prefix instruction. The AW register value is stored in address 24H of the register file.

<2> This shows the case where an instruction for data transfer to the memory space is used.

If the IRAM prefix instruction is added to the primitive block transfer instruction and BCD operation instruction, which specify the source block and destination block, it becomes effective for the destination block.

Also, the macro service control word area (008H to 03FH), the macro service work area (000H to 007H), and the area used by the macro service channel (008H to 0FFH) are allocated in overlapping fashion in the file space. If a specific macro service which requires work area (RTOPTRN) is not used, these work areas can be used as data space.

Figure 3-5. Register File Space

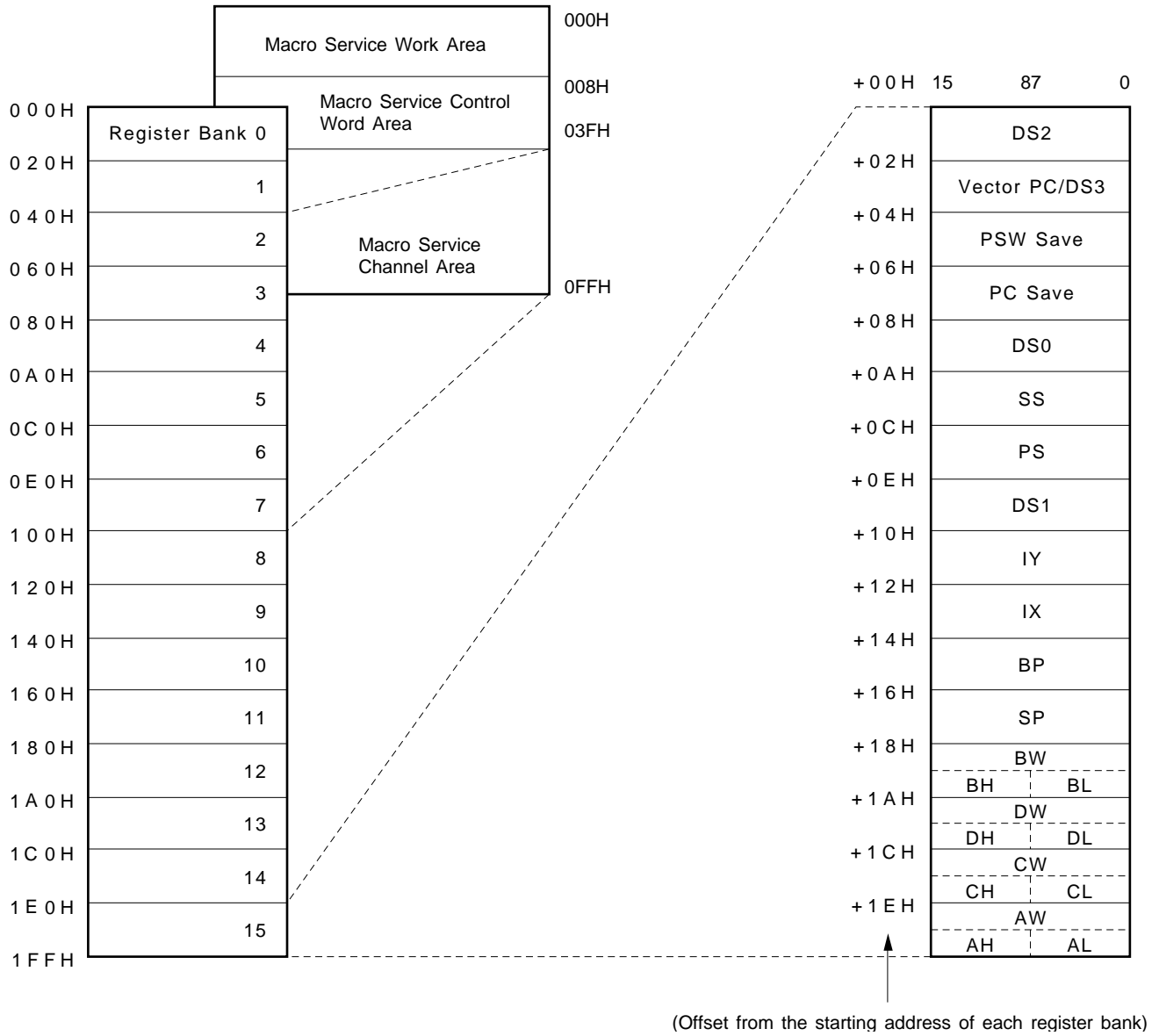

3.7 I/O SPACE

The V55PI has a 64K-byte I/O space.

The I/O space map is shown in Figure 3-6.

The I/O space is accessed using address bus/data bus and control signals (\overline{IORD} , \overline{IOWR} , etc).

0 is output from the unused high-order 8 bits of the address bus.

Wait cycles can be inserted in an I/O cycle by software and the READY pin.

The area FF80H to FFFFH of the I/O space is a reserved area, in which two V55PI on-chip peripheral DMA input/output read/write pointers (IOP) are allocated. The address of IOP0 is FF94H, and the address of IOP1 is FFB4H.

When the CPU executes an input/output instruction with an IOP address as an operand, the DMA controller performs a read/write of data in the DMA controller transfer buffer, with the IOP contents as the address value, and increments (or decrements) the IOP value automatically in accordance with the contents of the DMA control register. Therefore, data written by the DMA controller can be referenced by an input/output instruction, and conversely, data written by an input/output instruction can be transferred by the DMA controller.

Figure 3-6. I/O Map (64K Bytes)

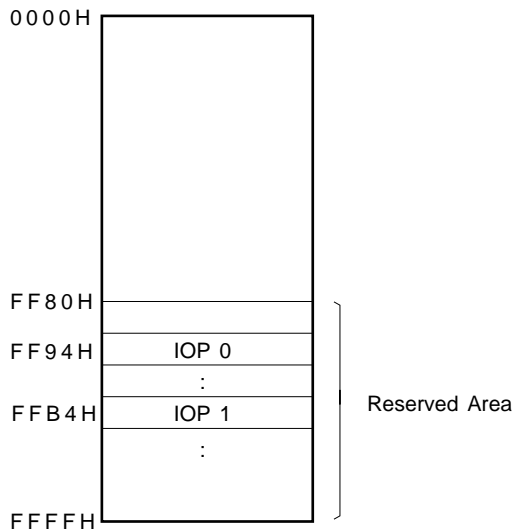

Remark IOPn corresponds to the DMA read/write pointer (DPTCn).

4. BUS CONTROL FUNCTIONS

With the V55PI pin, refer to 1.1.2 (1) "Pin function for bus control".

As regards pins which have an alternate function as port pins, when that function is used, the corresponding function must be selected by means of the port mode control register (PMCn).

4.1 WAIT FUNCTION

The V55PI divides the basic memory space (000000H to 0FFFFFFH) into a maximum of 4 blocks with a variable memory size, divides the uppermost extended memory space area (100000H to FFFFFFFH) into two areas with a variable memory size, and performs wait control for each block. The memory size of each block in the basic memory space is specified by the memory block control register (MBC).

Figure 4-1 shows the memory block configuration when A9H has been set for the MBC register value.

Figure 4-1. Partitioned Memory Control

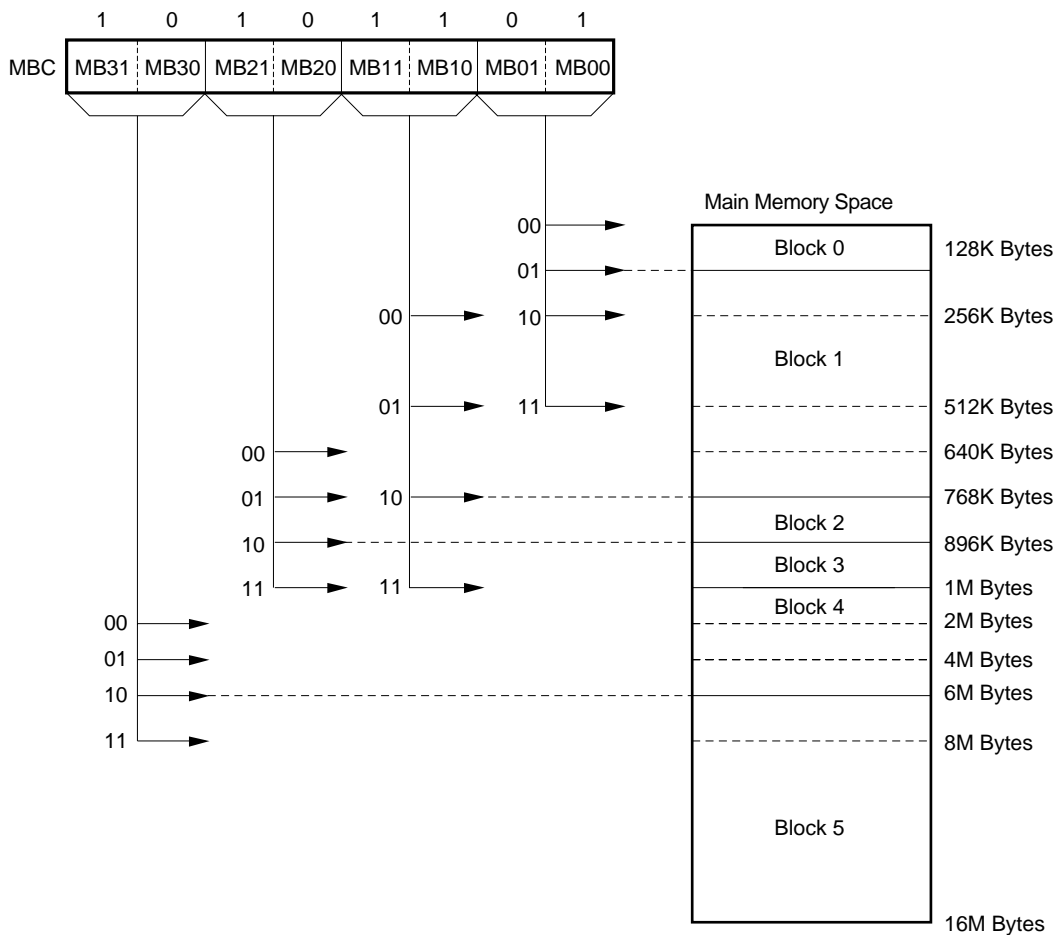
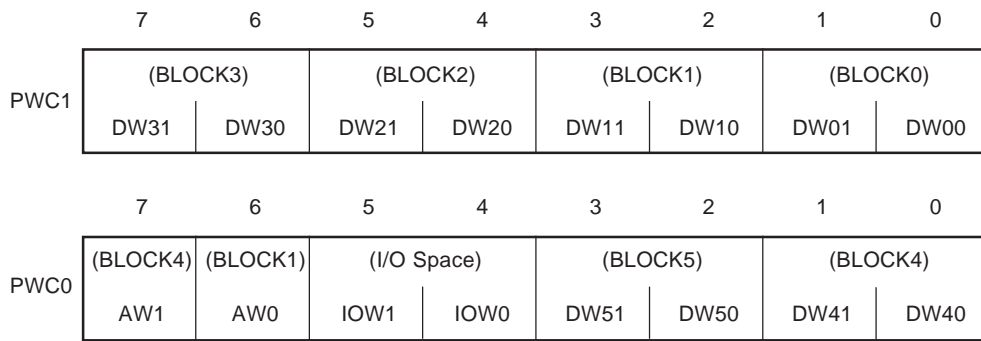

Figure 4-2. Memory Wait Control



Data Wait (DW, IOW)

DWn1/IOW1	DWn0/IOW0	Wait State
0	0	0 *1
0	1	1 *2
1	0	2 *2
1	1	3 *2

- * 1. READY signal is ignored.
- 2. Additional control by means of READY signal is also possible.

Address Wait (AW)

AWn		Wait State
AW0	0	Not inserted (block 1)
	1	Inserted (block 1)
AW1	0	Not inserted (block 4)
	1	Inserted (block 4)

4.2 REFRESH FUNCTION

The following functions are provided to refresh DRAM and pseudo-SRAM.

- Function to insert periodically a refresh cycle in a series of bus cycles
- Refresh address output function to refresh DRAM and pseudo-SRAM
- Function to generate a refresh cycle in hold mode and HALT mode.
- Function to insert a wait state in a refresh cycle

4.2.1 Refresh Mode Register (RFM)

The RFM register is an 8-bit register to control refresh operation.

A refresh cycle can be selected from the time base counter output tap.

While a refresh request is held by another bus cycle if the next refresh request is generated, only the latter is valid.

The RFM register value after a reset is 77H.

4.2.2 Wait Control in Refresh Cycle

A wait state can be inserted in a refresh cycle. The specified number of wait states is inserted for memory block 4 by the programmable wait control register (PWC0) or READY pin.

4.2.3 Refresh Address

Bus pins AD0 to AD15 and A16 to A19 are activated in a refresh cycle.

For each refresh cycle, the count is performed in one-address increments from x00000 to x1FFFFFF in the case of the external 8-bit bus width, and in two-address increments from x00001H to xFFFFFF in the case of the external 16-bit bus width (the minimum address is returned to after the maximum address).

After initialization by a reset, count-up is started from x00000H in the case of the external 8-bit bus width and x00001H in the case of the external 16-bit bus width.

In the case of the external 16-bit bus width, the refresh address minimum address bit (A0) is fixed at "1" and the $\overline{\text{DEX}}$ pin output is also fixed at "1".

A20 to A23 are undefined in a refresh cycle.

5. INTERRUPT FUNCTIONS

The V55PI incorporates a powerful interrupt controller (INTC) which controls multiple-interrupt servicing for a total of 25 maskable hardware interrupt requests: 19 internal and 6 external. The interrupt controller controls multiple-interrupt servicing based on programmable priority.

The following functions are provided as interrupt servicing modes: vectored interrupt function, macro service function, register bank switching function.

5.1 FEATURES

V55PI interrupt functions offer the following features:

- **Comprehensive servicing states for interrupt requests**

- Vectored interrupt function : Branch to interrupt service routine specified by vector table
- Register bank switching function : High-speed interrupt response by automatic register bank switching
- Macro service function : High-speed interrupt servicing by microprogram (firmware)

- 4-level programmable priority order control
- Interrupt multiprocessing control according to the priority
- Rich variety of macro service functions (following 7 modes) closely tied to V55PI on-chip peripheral hardware

EVCNT : Event count processing

BLKTRS : Data transfer between special function register and external memory buffer

BLKTRS-C : Data transfer between special function register and external memory buffer (with transfer data detection function)

DTACMP : Special function register status detection

DTADIF : Time measurement by timer capture function

RTOPTRN : Automatic control of real-time output port

DTACMP-M : Data transfer between external I/O and memory

- 7 external interrupt request inputs (NMI, INTP0 to INTP5)
- Maskable interrupt requests are individually maskable.

A list of interrupt sources is given in Table 5-1.

Table 5-1. Interrupt Sources (1/2)

Interrupt Classification	Default Priority	Interrupt Request Signal	Interrupt Source			Default Vector Table Number	Vectored Address	Macro Service	Register Bank Switching	Macro Service Control Word Address	
			Interrupt Request Control Register	Generating Source	Generating Unit						
Nonmaskable	1	NMI	—	NMI pin input	—	2	00008H	No	No	—	
	2	WDT		Watchdog timer overflow	WDT	8	00×20H	No	No		
Maskable	3	INTP0	IC9	INTP0 pin input	External	9	00×24H	Yes	Yes	012H	
	4	INTP1	IC10	INTP1 pin input		10	00×28H	Yes	Yes	014H	
	5	INTP2	IC11	INTP2 pin input		11	00×2CH	Yes	Yes	016H	
	6	INTP3	IC12	INTP3 pin input		12	00×30H	Yes	Yes	018H	
	7	INTP4	IC13	INTP4 pininput		13	00×34H	Yes	Yes	01AH	
	8	INTP5	IC14	INTP5 pin input		14	00×38H	Yes	Yes	01CH	
	Maskable	9	INTCM00	IC16	CM00 match detection	Timer	16	00×40H	Yes	Yes	020H
		10	INTCM01	IC17	CM01 match detection		17	00×44H	Yes	Yes	022H
		11	INTCM10	IC18	CM10 match detection		18	00×48H	Yes	Yes	024H
		12	INTCM11	IC19	CM11 match detection		19	00×4CH	Yes	Yes	026H
		13	INTCM21	IC20	CM21 match detection		20	00×50H	Yes	Yes	028H
		14	INTCM31	IC21	CM31 match detection		21	00×54H	Yes	Yes	02AH
	Maskable	15	INTD0	IC22	DMA channel 0_main	DMA	22	00×58H	Yes	Yes	02CH
		16	INTD0S	IC23	DMA channel 0_sub		23	00×5CH	Yes	Yes	02EH
		17	INTD1	IC24	DMA channel 1_main		24	00×60H	Yes	Yes	030H
		18	INTD1S	IC25	DMA channel 1_sub		25	00×64H	Yes	Yes	032H

Table 5-1. Interrupt Sources (2/2)

Interrupt Classification	Default Priority	Interrupt Request Signal	Interrupt Source			Default Vector Table Number	Vectored Address	Macro Service	Register Bank Switching	Macro Service Control Word Address
			Interrupt Request Control Register	Generating Source	Generating Unit					
Maskable	19	INTSER0	IC26	UART reception error (ch0)	Serial I/F	26	00x68H	No	Yes	034H
	20	INTSER1	IC27	UART reception error (ch1)		27	00x6CH	No	Yes	036H
	21	INTSR0/ INTCSI0	IC28	UART reception (ch0)/		28	00x70H	Yes	Yes	038H
				Serial transmission/reception (ch0)				Yes	Yes	
	22	INTSR1/ INTCSI1	IC29	UART reception (ch1)/		29	00x74H	Yes	Yes	03AH
				LDMA channel 5				Yes	Yes	
	23	INTST0	IC30	UART transmission (ch0)	30	00x78H	Yes	Yes	03CH	
	24	INTST1	IC31	UART transmission (ch1)	31	00x7CH	Yes	Yes	03EH	
	25	INTSIT	IC32	STM match detection	SIT	32	00x80H	No	Yes	—
26	INTPAI	IC36	Parallel I/F	Parallel I/F	36	00x90H	Yes	Yes	—	
27	INTAD	IC37	A/D converter	A/D converter	37	00x94H	Yes	Yes	008H	
Software	—	—	—	Divide error	—	0	00000H	No	No	—
				BRK flag (single-step)		1	00004H	No	No	
				BRK3 instruction		3	0000CH	No	No	
				BRKV instruction		4	00010H	No	No	
				CHKIND instruction		5	00014H	No	No	
				Input/output instruction (IBRK flag)		6	00018H	No	No	
				BRK imm8		*	00x*H	No	No	
				BRKCS instruction		—	—	No	Yes	
				FP0 instruction/ Exception trap		7	0001CH	No	No	

* Indicates that the value is variable in the range 0 to 255 (0 to FFH).

Remarks "x" indicates that the value is determined by the V0 and V1 bits of the IMC register.

5.2 INTERRUPT RESPONSE METHODS

The V55PI has three interrupt response methods: a vectored interrupt function, register bank switching function, and macro service function. In the case of a maskable interrupt request, one of these functions can be selected by means of the interrupt request control register (IC_{xx}) for each interrupt source according to the purpose of the interrupt. The on-chip interrupt controller handles interrupt requests according to the set response method.

5.2.1 Vectored Interrupts

A vectored interrupt can only be acknowledged in the interrupt enabled state (EI state). When a vectored interrupt is acknowledged, the CPU enters the interrupt disabled state (DI state), and the current PSW contents and PC and PS contents are saved to the stack. Then the corresponding vector is selected from the vector table, and the interrupt service routine is started at the address indicated by that vector. Vector numbers are fixed for each interrupt source. In the DI state, interrupts are held pending, and are acknowledged when the EI state is set again.

The return from the interrupt is performed by an RETI instruction. In the case of a hardware interrupt other than a non-maskable interrupt, an FINT instruction must be executed before the return instruction. When a return is made from an interrupt, the PC, PS and PSW are restored from the stack.

Figure 5-1. Interrupt Acknowledge Operation (Performed in Sequence <1> → <4>)

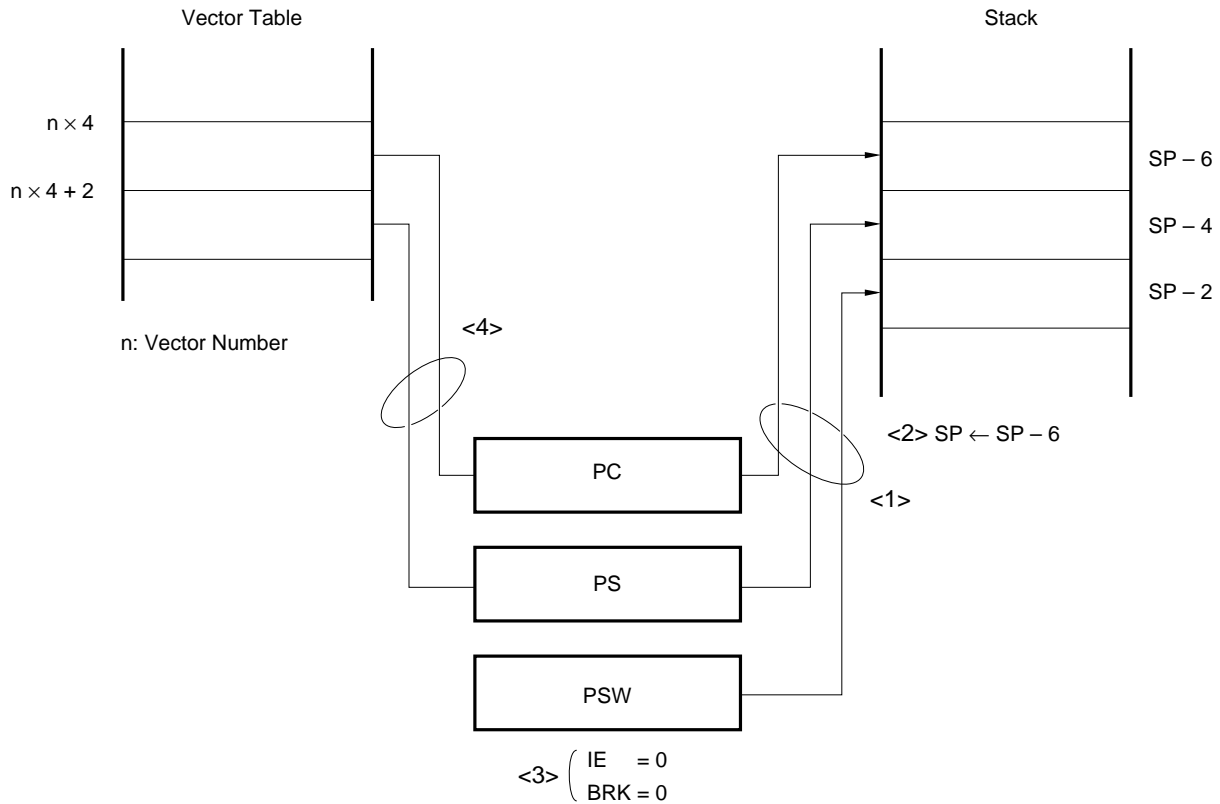

5.2.2 Register Bank Switching Function

In the V55PI, general register sets are mapped onto on-chip RAM, and register sets can be held in up to 16 banks. Interrupt servicing is performed by automatically switching the register bank when a BRKCS or TSKSW instruction is executed or when an interrupt is responded to. Because saving of registers to the stack previously performed by software is not required, high-speed switching of the program execution environment is possible.

The register bank switching sequence is performed as follows (See **Figure 5-2**).

- <1> The contents of PSW is saved to temporary register.
- <2> The register bank is switched.
- <3> IE and BRK are set to 0.
- <4> The contents of PSW which is saved to the PC and the temporary register are saved to the saving area, respectively.
- <5> The interrupt service routine start address offset value is loaded from the vector PC area in the register bank to PC.

**Figure 5-2. Register Bank Switching Sequence
(In Case of Register Bank Switching by Interrupt)**

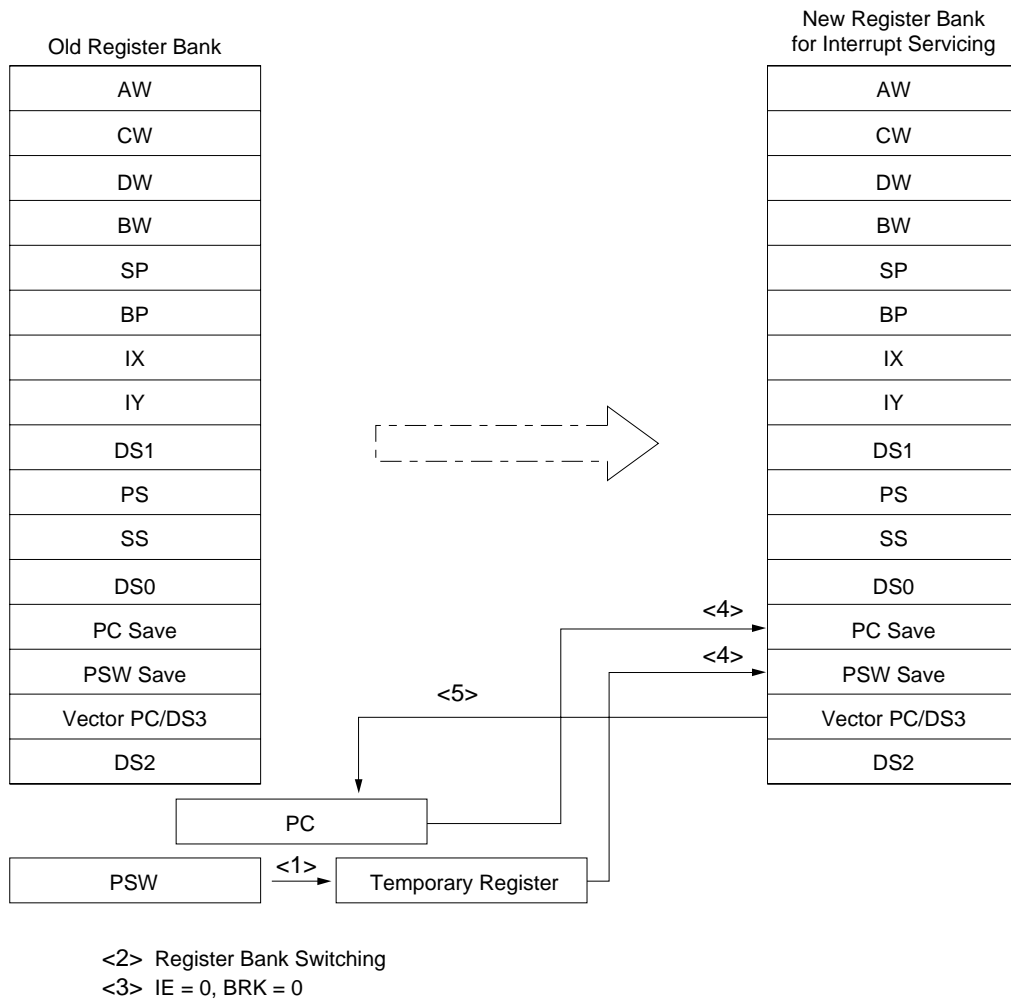

5.2.3 Macro Service Function

The macro service function performs processing of simple data transfers, etc., by means of a microprogram (CPU internal dedicated firmware) started by generation of an interrupt request. The simple, standardized interrupt servicing which was coded and executed by a user program is performed automatically.

Macro service processing is caused by an interrupt request and is performed. Macro service is designed to minimize as far as possible the frequency of generation of interrupts consisting mainly of software processing, hold down the software overhead due to a series of processes used in an interrupt (register saving, initialization, register restoration, return from the interrupt routine), and improve the CPU efficiency.

Processing performed by the macro service is transparent in terms of software, and it is possible to process as a single mass of data what was previously processed by software byte by byte, allowing more efficient programming.

The V55PI macro service supports not only the simple data transfers used in the V25 and V35, but also various operating modes closely linked to the on-chip V55PI peripheral hardware, as shown below.

(a) EVTCNT (EVENT COUNTER)

The counter is updated each time the macro service are generated, and when the counter reaches 0 the macro service for the corresponding interrupt source is terminated and a vectored interrupt or a register bank switching is generated.

(b) DTACMP (DATA COMPARE)

The interrupt source specific SFR and preset byte data are compared, and if they match, the macro service for the corresponding interrupt source is terminated and a vectored interrupt or register bank switching is generated.

(c) DTADIF (DATA DIFFERENCE)

The difference in using the timer/counter unit capture register is calculated. This is initiated by a timer interrupt: the value of the capture register latched last time is subtracted from the value of the capture register latched this time, and the result is stored in the previously specified memory buffer.

When processing has been performed the previously set number of times, the corresponding interrupt source macro service is terminated, and a vectored interrupt or register bank switching is generated.

(d) BLKTRS (BLOCK TRANSFER)

A data transfer is performed between the previously specified memory buffer and SFR.

When the previously set number of data transfers have been performed, the corresponding interrupt source macro service is terminated, and a vectored interrupt or register bank switching is generated.

(e) BLKTRS-C (BLOCK TRANSFER WITH CHARACTER SEARCH)

A data transfer is performed between the previously specified memory buffer and SFR. When the previously set number of data transfers have been completed, or when the transfer data matches the previously set character data, the corresponding interrupt source macro service is terminated, and a vectored interrupt or register bank switching is generated.

(f) RTOPRTN (RTOP TRANSFER)

Data to be output to the real-time output port is transferred to the port 7 buffer (P7H, P7L), and data which specifies interval for output to the real-time output port is transferred to the timer compare register (CM00, CM01).

(g) DTACMP-M (DATA COMPARE WITH CHARACTER MASK)

The logical product of the status data read from the external I/O and the previously set mask data is performed. The previously set byte data is compared with the result. If it matches, a data transfer is performed between the external I/O and memory. If it does not match, or if the previously set number of data transfers have been performed, the corresponding interrupt source macro service is terminated, and a vectored interrupt or register bank switching is generated.

6. DMA FUNCTION (DMA CONTROLLER)

The V55PI incorporates a 2-channel DMA controller which controls execution of memory-to-I/O or memory-to-memory DMA transfers on the basis of DMA requests generated by an on-chip peripheral hardware (serial interface, parallel interface, or timer), the external DMARQ pin or a software trigger.

Each channel of the DMA controller further comprises a main channel and a sub-channel: the operating mode determines whether the main channel and sub-channel are used as a single channel or as separate channels. When used as separate channels, function for a maximum of 4 channels can be constructed.

6.1 FEATURES

- Two independent DMA channels (max. 4-channel configuration possible)
- Four transfer modes
 - Single transfer mode ... One DMA transfer cycle is executed in response to one DMA request.
 - Demand release mode ... Consecutive DMA transfer cycles are executed while DMA request is active.
 - Single-step mode ... DMA transfer cycles and CPU bus cycles are executed alternately after DMA request generation.
 - Burst mode ... For each DMA request, the specified number of DMA transfer cycles are executed consecutively.
- Five operating modes
 - Intelligent DMA mode–1 (ring buffer system) ... DMA transfers to ring buffer are controlled.
 - Intelligent DMA mode–2 (counter control system) ... Transfer data is transferred consecutively, divided into an arbitrary number of bytes.
 - Next address specification mode ... Consecutive transfers are possible between different transfer buffers.
 - 2-channel operating mode ... Main channel and subchannel are used as independent channels.
 - Memory-to-memory transfer mode ... Two bus cycles are started for one DMA transfer cycle, and memory-to-memory transfer is executed.
- 3 clocks/1 bus cycle (no wait case)
- Transfer objects
 - External I/O \longleftrightarrow memory ... 1 DMA transfer cycle/1 bus cycle
 - SFR (internal I/O) \longleftrightarrow memory ... 1 DMA transfer cycle/1 bus cycle
 - Memory \longleftrightarrow memory (memory includes SFR) ... 1 DMA transfer cycle/2 bus cycles
- Byte transfer/word transfer selectable
- Transfer address increment/decrement/non-update selectable
- DMA transfer end signal (TCE0, TCE1) output
- 24-bit DMA memory address registers (MAR0, MAR1)
- 21-bit terminal counters (TC0, TC1)
- External DMA request signal input pins (DMARQ0, DMARQ1: alternate function as port P80 and P81 pins)
- External DMA acknowledge signal output pins (DMAAK0, DMAAK1)

Table 6-1. Transfer Modes

Transfer Mode	DMA Start Source			STOP Method	Interrupt
	On-Chip Peripheral	Software Trigger	DMARQ Pin		
Single transfer mode	Available	Available	Available	Reset of EDMA bit of DMAMn register	Acknowledged
Demand release mode	Not Available	Not Available	Available	Stops when the DMARQ pin is driven low during the transfer. Reset of EDMA bit of DMAMn register	Not acknowledged during transfer. Acknowledged at other times.
Single step mode	Available*	Available	Available	Reset of EDMA bit of DMAMn	Acknowledged register
Burst mode	Available*	Available	Available	None (stop disabled during the transfer)	Not acknowledged

* The DMA start source is an on-chip timer interrupt, and transfer is possible only when the transfer I/O specification is external.

Table 6-2. Correspondence Between Operating Modes and Transfer Modes

Operating Mode	Transfer Type	Possible Transfer Modes*				
		<1>	<2>	<3>	<4>	
Intelligent DMA mode-1 (ring buffer method)	I/O (SFR) → Memory	Yes	Yes	No	No	
Intelligent DMA mode-2 (counter control method)	Memory → I/O (SFR)	No	No	Yes	Yes	
Next address specification mode	I/O (SFR) ↔ Memory	Yes	Yes	No	No	
2-channel operating mode	(Stop at end)	I/O ↔ Memory	Yes	Yes	Yes	Yes
	(Repetition)	I/O ↔ Memory	Yes	Yes	Yes	No
Memory-memory transfer mode	(Stop at end)	Memory ↔ Memory	Yes	No	Yes	Yes
	(Repetition)	Memory ↔ Memory	Yes	No	Yes	No

* Transfer modes
 <1> Single transfer mode
 <2> Demand release mode
 <3> Single step mode
 <4> Burst mode

7. SERIAL INTERFACE FUNCTIONS

The V55PI is equipped with a 2-channel serial interface unit (ch0, ch1).
 The two communication protocols supported by the V55PI are as follows:

- (1) Asynchronous UART
- (2) Clocked CSI
 - SBI: 2-wire serial bus interface
 - IOE: I/O expansion 3-wire serial interface

7.1 FEATURES

- Two communication protocols supported
- Two serial channels
- Wake-up function
- On-chip dedicated baud rate generator
- DMA request generated by completion of transmission/reception (transmit/receive data DMA transfer is capable)

7.2 PROTOCOLS

The UART is an asynchronous serial interface which achieves data synchronization by means of start/stop bits, and is functionally enhanced UART functions compared with previous single-chip microcontroller.

The CSI (clocked serial interface) is a clocked serial interface which achieves synchronization by transmission/reception of a clock. The CSI is a subset of the standard serial bus interface specification for NEC single-chip microcontrollers, and I²C functions are not supported. The wake-up release function is implemented by using macro service.

Table 7-1. Supported Protocols

Serial Interface Unit	Supported Protocols		
	Clocked (CSI)		Asynchronous (UART)
	SBI	IOE	
Channel 0	Yes	Yes	Yes
Channel 1	No	Yes	Yes

The UART function or CSI function can be programmably selected for each channel. Protocol selection is performed by means of the protocol selection register (ASP).

7.3 UART

7.3.1 Features

- Transfer rate: 95 to 390 Kbps (with 12.5 MHz system clock ϕ)
123 to 500 Kbps (with 16 MHz system clock ϕ)
- Full-duplex operation capability
- On-chip dedicated (transmission and reception) baud rate generators
- Wake-up function
- Zero parity function
- Parity error detection
- Framing error detection
- Overrun error detection
- Three dedicated UART interrupt sources
 - UART receive error interrupts (INTSER0, INTSER1)
 - UART reception interrupts (INTSR0, INTSR1)
 - UART transmission interrupts (INTST0, INTST1)
- Macro service function
 - UART reception interrupts (INTSR0, INTSR1)
 - UART transmission interrupts (INTST0, INTST1)

Figure 7-1. UART Block Diagram

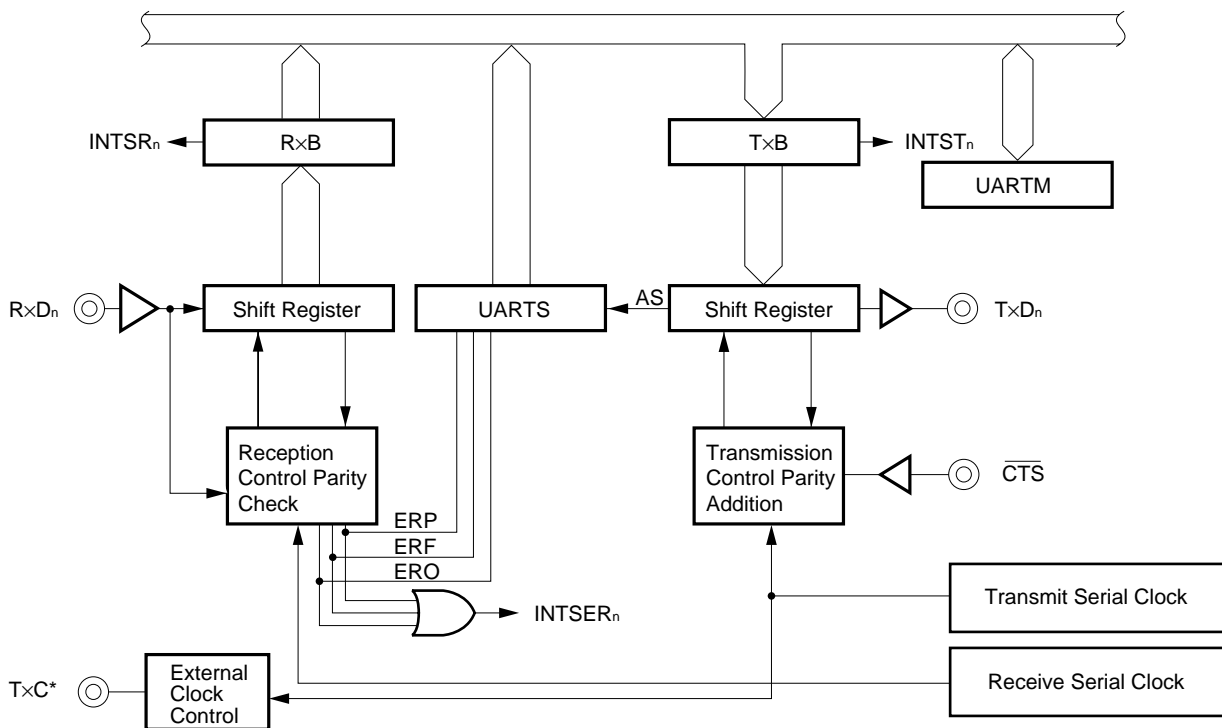

* Channel 0 only

7.4 CLOCKED SERIAL INTERFACE (CSI)

7.4.1 Features

- Transfer speed: Max. 3.125 Mbps (with 12.5 MHz system clock ϕ)
Max. 4.0 Mbps (with 16 MHz system clock ϕ)
- Half-duplex communication
- Data length: 8-bit unit
- External/internal clock selection function
- Data MSB-first/LSB-first selection function
- SBI mode (2-wire NEC type serial bus) ... ch0 only
 - Address/command/data identification function
 - Function for chip selection by address
 - Wake-up function
 - Acknowledge signal ($\overline{\text{ACK}}$) control function
 - Busy signal ($\overline{\text{BUSY}}$) control function

The V55PI clocked serial interface has the following two operating modes.

(1) 3-wire serial I/O mode (IOE mode)

In this mode, 8-bit data transfer is performed using three lines: the serial clock ($\overline{\text{SCK}}$), and serial data input and output (SI, SO). This mode is useful when connecting an I/O device, display controller, etc., which incorporates a conventional clocked serial interface.

The functions of the V25 and V25+™ have been enhanced, and data MSB-first/LSB-first selection is possible.

(2) Serial bus interface mode (SBI mode)

In the SBI mode, communication is performed with multiple devices by means of two lines: the serial clock ($\overline{\text{SCK}}$) and the serial bus interface (SB0 or SB1).

This mode conforms to the NEC serial bus format.

In the SBI mode, the sender can output to the serial data bus an address to select the target device for serial communication, a command which gives a directive to the target device, and actual data. Thus there is no need for the line for handshaking required when multiple devices are connected with a conventional clocked serial interface, allowing input/output ports to be used efficiently.

In addition, wake-up release is performed using macro service.

8. PARALLEL INTERFACE FUNCTIONS

The V55PI incorporates a parallel interface unit for data input on a Centronics specification interface, and general data input/output.

8.1 FEATURES

The following features are provided as parallel interface functions:

- Centronics specification interface compatibility
- Input/output mode switchable by software
- BUSY signal manipulable by software
- BUSY signal and $\overline{\text{ACK}}$ signal output timing settable
- Initialization by external interrupt
- Dedicated parallel interface interrupt source
 - Parallel interface interrupt (INTPAI)
- DMA request signal generation in parallel transmission/reception
 - INTPAI functions as a DMA start trigger.
- Signal pin input/output characteristic is TTL level (Centronics specification interface)

Figure 8-1. Parallel Interface Block Diagram

(a) Input mode

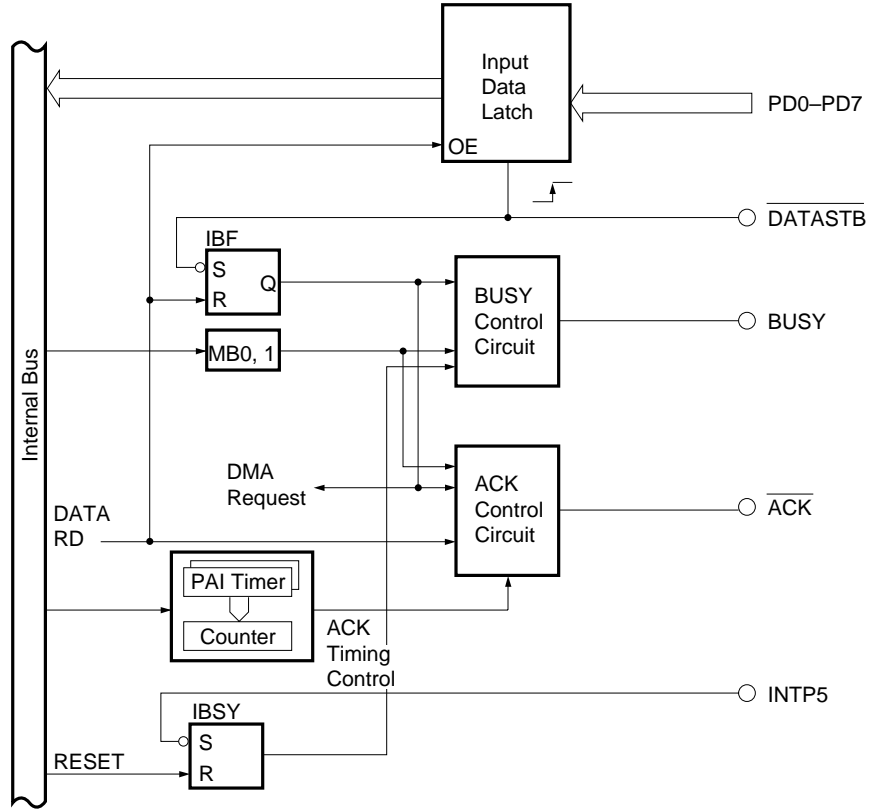

(b) Output mode

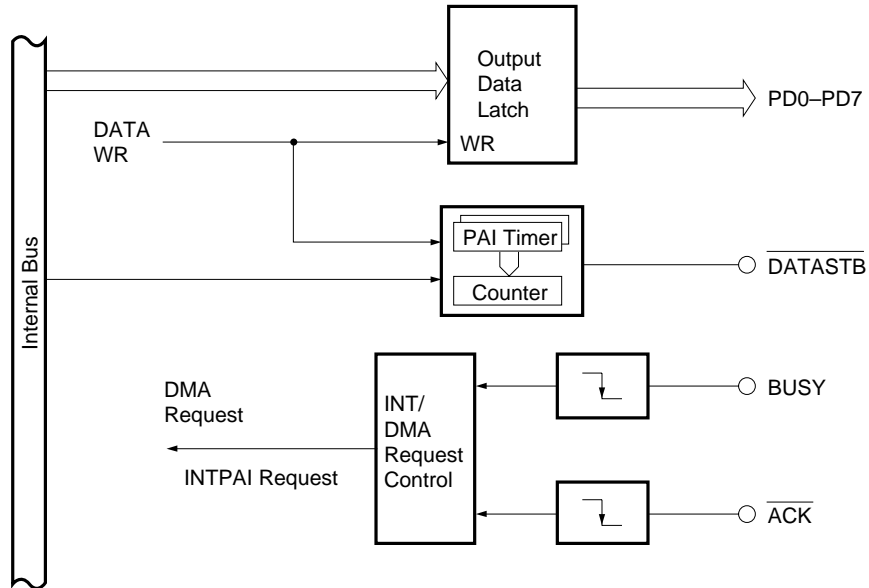

9. TIMER FUNCTION

The V55PI timer unit can be used as an interval timer, free-running timer and event counter. It is also possible to manipulate P7 as a real-time output port, synchronized with interrupt requests generated by the timer. The normal timer function and real-time output port function are described here.

9.1 FEATURES

The timer function offers the following features.

- 16-bit timer × 4
- Two count clock sources are selectable
 - System clock scaled output selectable ($\phi/8$, $\phi/32$: system clock ϕ)
 - External input pulses from TI pin
- External count output signal (TOn output)
- Three 16-bit capture registers on chip (external interrupt input signals INTP0 to INTP2 as triggers)
- Six dedicated timer unit interrupt source (INTCM00, INTCM01, INTCM10, INTCM11, INTCM21, INTCM31)
- Real-time output port function synchronized with timer interrupts

9.2 TIMER UNIT CONFIGURATION

The timer unit configuration is shown in Figure 9-1, and the function of each timer in Table 9-1.

Table 9-1. Timer Functions

		Timer 0	Timer 1	Timer 2	Timer 3	
Function	Count function	Available	Available	Available	Available	
	Capture function	Available	Available	Not Available	Not Available	
	Compare function	Available	Available	Available	Available	
	Timer output function	Toggle output	Available	Not Available	Available	Not Available
		Set/reset output	Not Available	Not Available	Available	Available
Cascading		Not Available	Not Available	Available		

Figure 9-1. Timer Unit Block Diagram

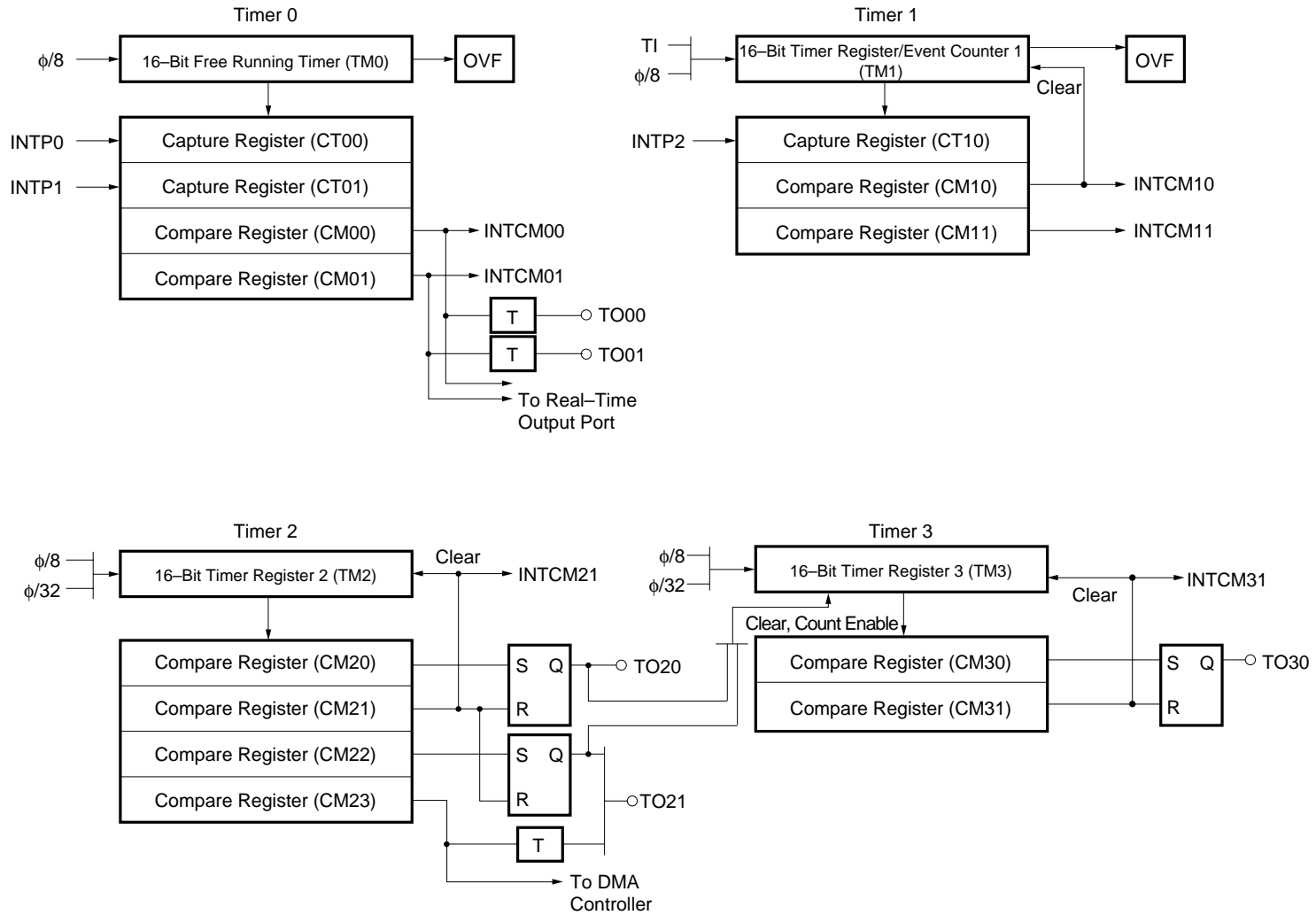

9.3 REAL-TIME OUTPUT PORT FUNCTION

Port 7 of the V55PI incorporates a real-time output port function, and can output the contents of the port 7 buffer (P7H, P7L) at programmable intervals from timer 0 bit-wise.

9.3.1 Real-Time Output Port Configuration

The real-time output port configuration is shown in Figure 9-2. It comprises the following buffer registers, output and control registers.

(1) Port 7 buffer (P7H, P7L)

The buffer registers hold the data to be output next when port 7 is set to the real-time output port mode.

The port 7 buffer contents are not affected by reset input.

(2) Real-time output port (RTP)

Real-time output port output data is held in this port after being taken from the port 7 buffer, and output from the pins.

RTP can be read or written to by an 8-bit or single-bit manipulation instruction (unlike the port 7 output port).

(3) Real-time output port delay specification register (RTPD) and delay counter

This register is set and used when using the mode in which a delay time is inserted in the timing for output from the real-time output port (RTP) to the output pins.

If the P7L bit is set to "0", "0" is output to the corresponding output pin bit after the elapse of the delay time equivalent to the count clock cycle time set in the real-time output port delay specification register after the time at which the transfer trigger is generated. The delay time in this case is counted by the delay counter.

(4) Real-time output port control register (RTPC)

RTPC specifies the operating mode of the real-time output port. It is possible to specify whether or not a delay is to be inserted when data is output, the timing for transferring data to the port 7 buffer, the transfer timing trigger, and so on.

Figure 9-2. Real-Time Output Port Operation

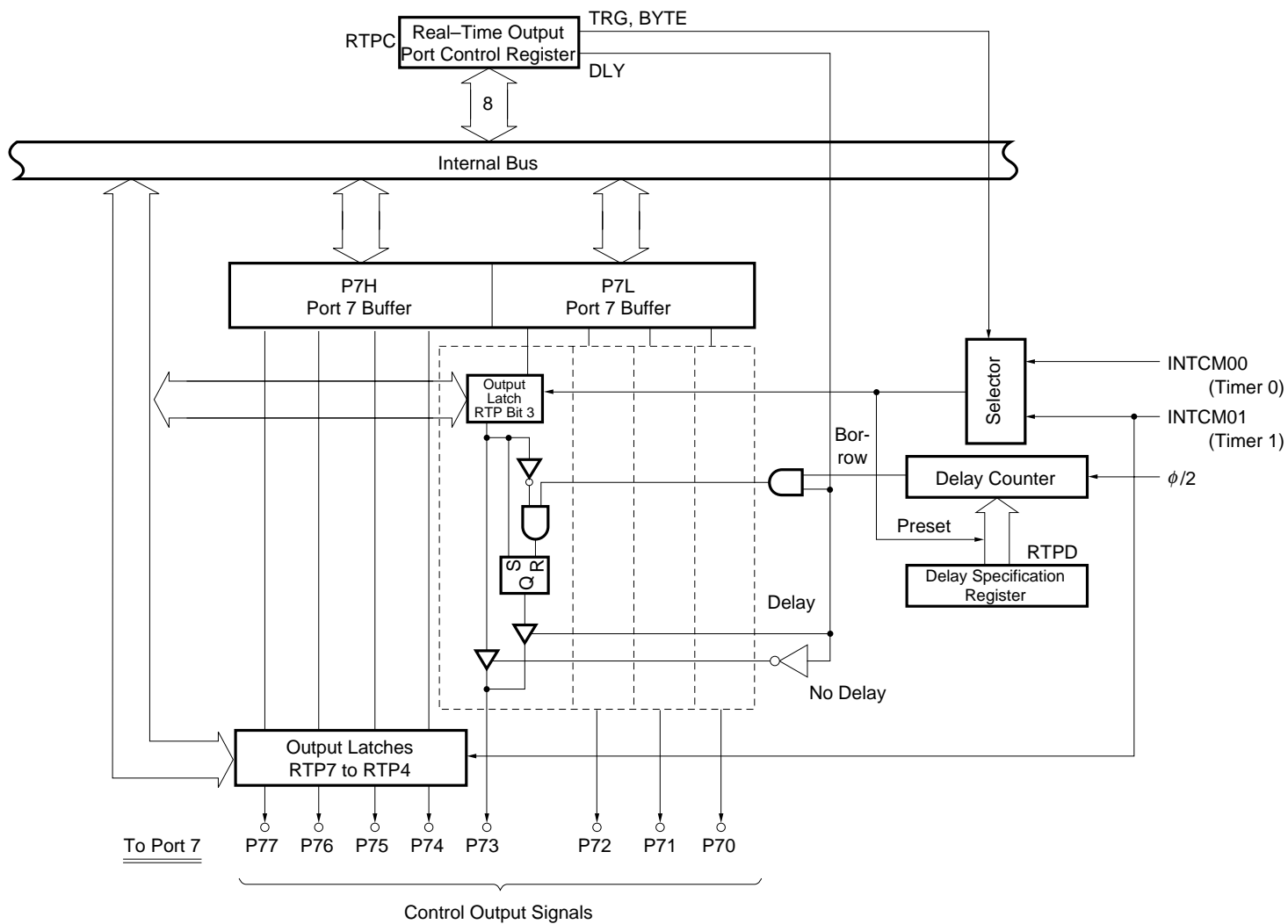

9.3.2 Real-Time Output Port Operation

Real-time output port specification is performed bit-wise by the port 7 mode control register (PCM7).

Port 7 (P7), the port 7 buffer (P7H, P7L) and the real-time output port can be accessed as real-time output ports.

Data output is performed as described below.

When output data is written in the port 7 buffer (P7H, P7L), the port 7 buffer contents are transferred to the real-time output port (RTP) and output to the pins in synchronization with the timing of an interrupt request from timer 0 (INTCM00, INTCM01), or a write to the TRG bit in the control register (RTPC).

An example of the direct control of the output pattern for a real-time output port and the output interval is shown in Figure 9-3.

Update data is transferred from the two data storage areas set beforehand in the external memory space to the real-time output function buffer registers (P7H, P7L) and compare registers (CM00, CM01).

Figure 9-3. Real-Time Output Port Stepping Motor Control

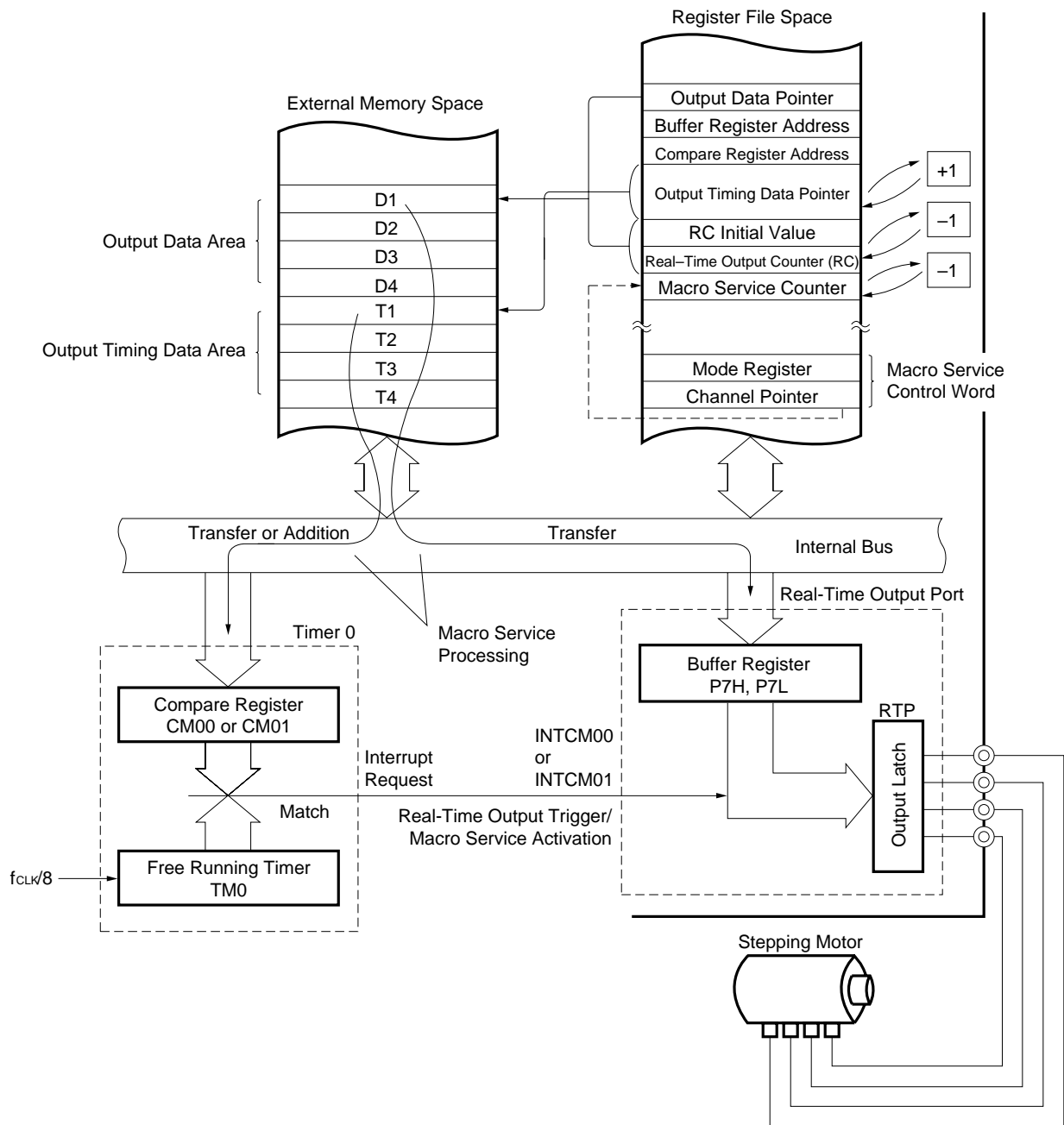

In particular, it is possible to insert a delay time in the timing for output by setting the real-time output port delay specification register (RTPD) pins. If the P7L bit is changed from "1" to "0", it is possible to perform output after inserting a delay time of $2 \times$ the system clock set in the RTPD from the timing at which the transfer trigger is generated. In this case, "0" is output from the corresponding output pin. This delay is counted by the delay counter.

10. PWM UNIT

The V55PI is provided with an 8-bit precision PWM (pulse width modulation) signal output function.

PWM output can be used as a digital-to-analog conversion output by connecting a low-pass filter, etc., externally. This is ideal for the actuator control signal for motors, etc.

10.1 FEATURES

The PWM unit offers the following features:

- PWM output pulse active level selectable
- Frequency: 25 MHz (with 12.5 MHz system clock ϕ)
 - PWM cycle: 40.96 μ s
 - : 32 MHz (with 16 MHz system clock ϕ)
 - PWM cycle: 32.00 μ s
- Output pulse width (duty): 0, 1/256,, 255/256
 - Resolution: 160 ns (with 12.5 MHz system clock ϕ)
 - 125 ns (with 16 MHz system clock ϕ)

10.2 PWM UNIT CONFIGURATION

The configuration of the PWM unit is shown in Figure 10-1.

The PWM unit consists of the PWM register (PWM) and PWM control register (PWMC), and an 8-bit counter.

The PWM register controls the pulse width (duty) in the PWM output mode. The 8-bit counter is set to 00H by reset input. The PWM register is not affected by reset input.

Figure 10-1. PWM Unit Block Diagram

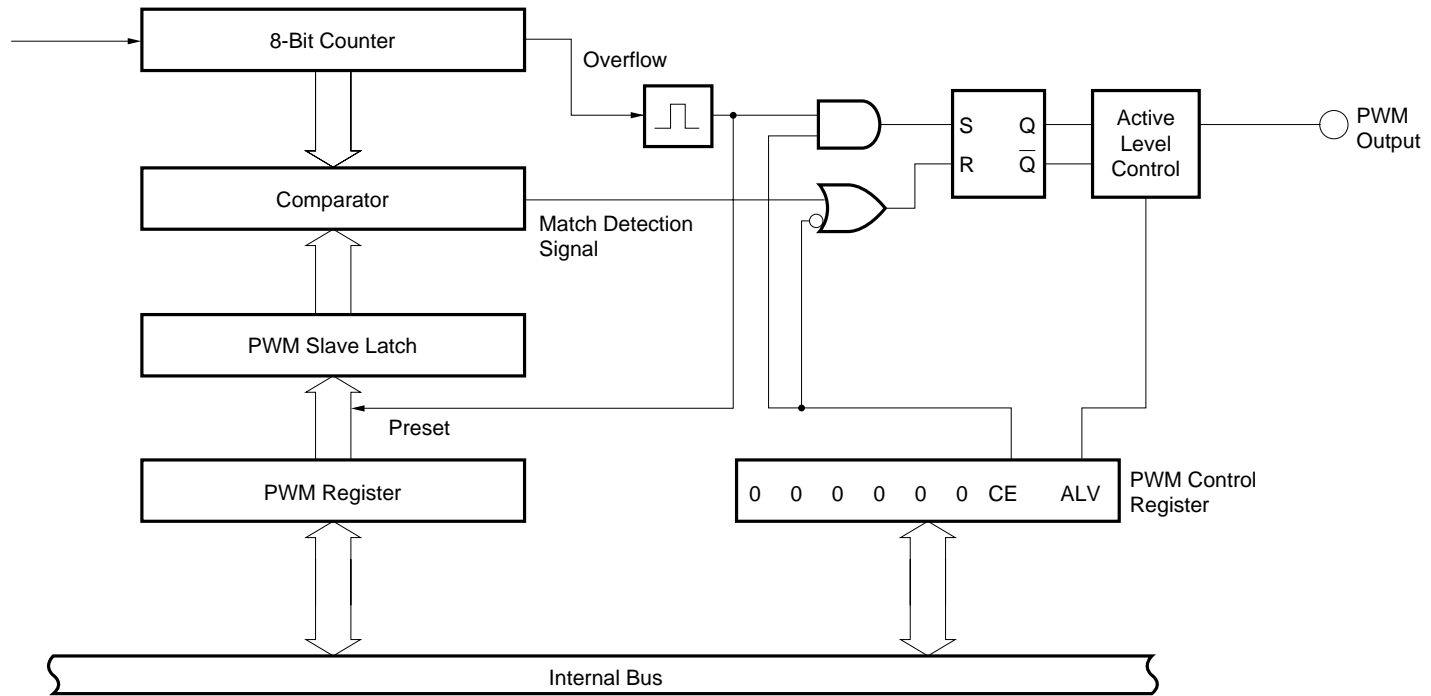

11. WATCHDOG TIMER FUNCTION

The watchdog timer is a function for preventing inadvertent program looping and deadlocks.

11.1 FEATURES

- Three overflow times settable (8.1, 32.7, 131.0 [ms]: system clock $\phi = 16$ MHz) (10.4, 41.9, 167.7 [ms]: system clock $\phi = 12.5$ MHz)
- Output pin provided ($\overline{\text{WDTOUT}}$ pin) which can be directly connected to the $\overline{\text{RESET}}$ pin

11.2 WATCHDOG TIMER CONFIGURATION AND OPERATION

Non-generation of a watchdog timer interrupt enables normal operation of the program or system to be confirmed. To use the watchdog function, an instruction (RSTWDT) to clear the watchdog timer (start the count) must be included in at fixed intervals in the program execution time, at the start of a subroutine, etc.

If the instruction which clears the watchdog timer is not executed within the set time and the watchdog timer overflows, a watchdog timer interrupt (INTWDT) is generated and the low-level signal is output to the $\overline{\text{WDTOUT}}$ pin to report a program error.

The watchdog timer configuration is shown in Figure 11-1.

Figure 11-1. Watchdog Timer Configuration Diagram

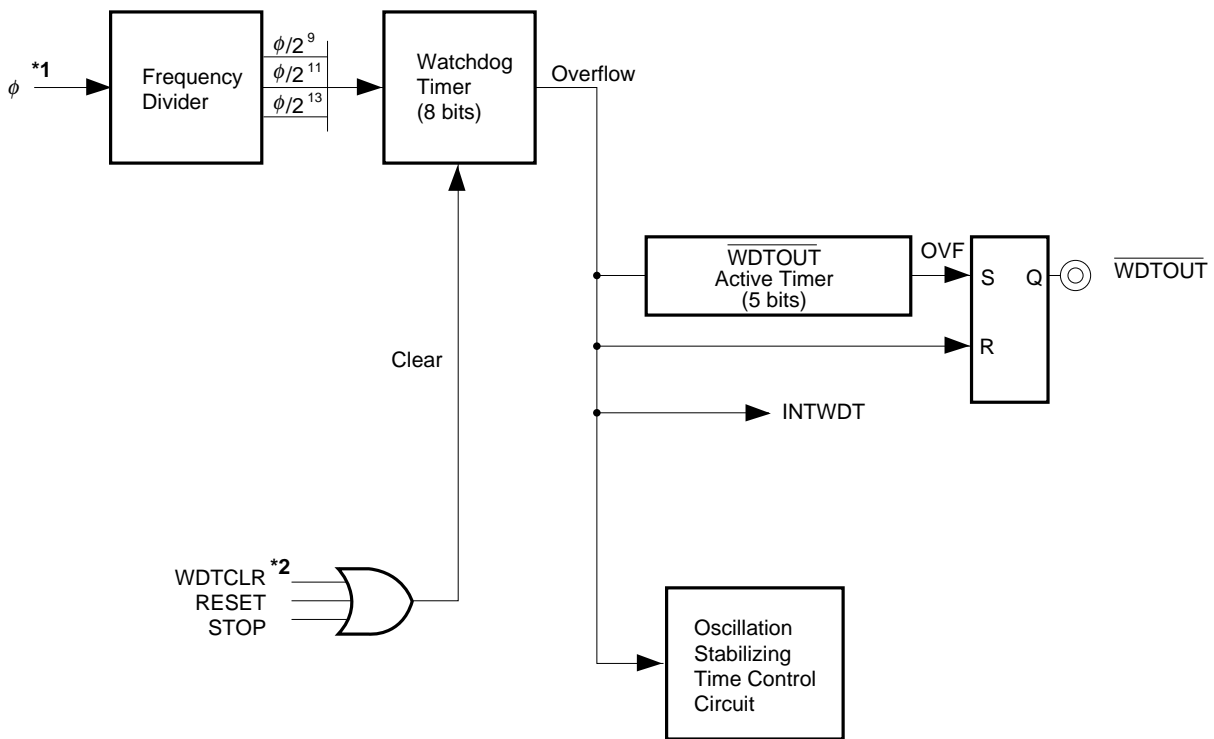

- * 1. ϕ : System clock
- * 2. WDTCLR: Watchdog timer clearance by instruction

12. A/D CONVERTER FUNCTION

The V55PI incorporates a high-speed, high-precision 8-bit analog/digital (A/D) converter with four analog inputs (ANI0 to ANI3). The A/D converter uses the successive approximation method, and is provided with four A/D conversion result registers (ADCR0 to ADCR3) which hold the conversion results.

12.1 FEATURES

The A/D converter offers the following features:

- Incorporates four 8-bit A/D conversion result registers.
- Four analog input pins (ANI0 to ANI3)
- Two A/D converter conversion operating modes
 - Scan mode : Performs conversion by selecting multiple analog inputs in sequence.
 - Select mode : Performs continuous conversion with only one pin used as the analog input.
- Two conversion start methods
 - Hardware start : Started by trigger input (INTP4)
 - Software start : Started by A/D converter mode register (ADM) bit setting
- Generation of conversion end interrupt request (INTAD)

Figure 12-1. A/D Converter Block Diagram

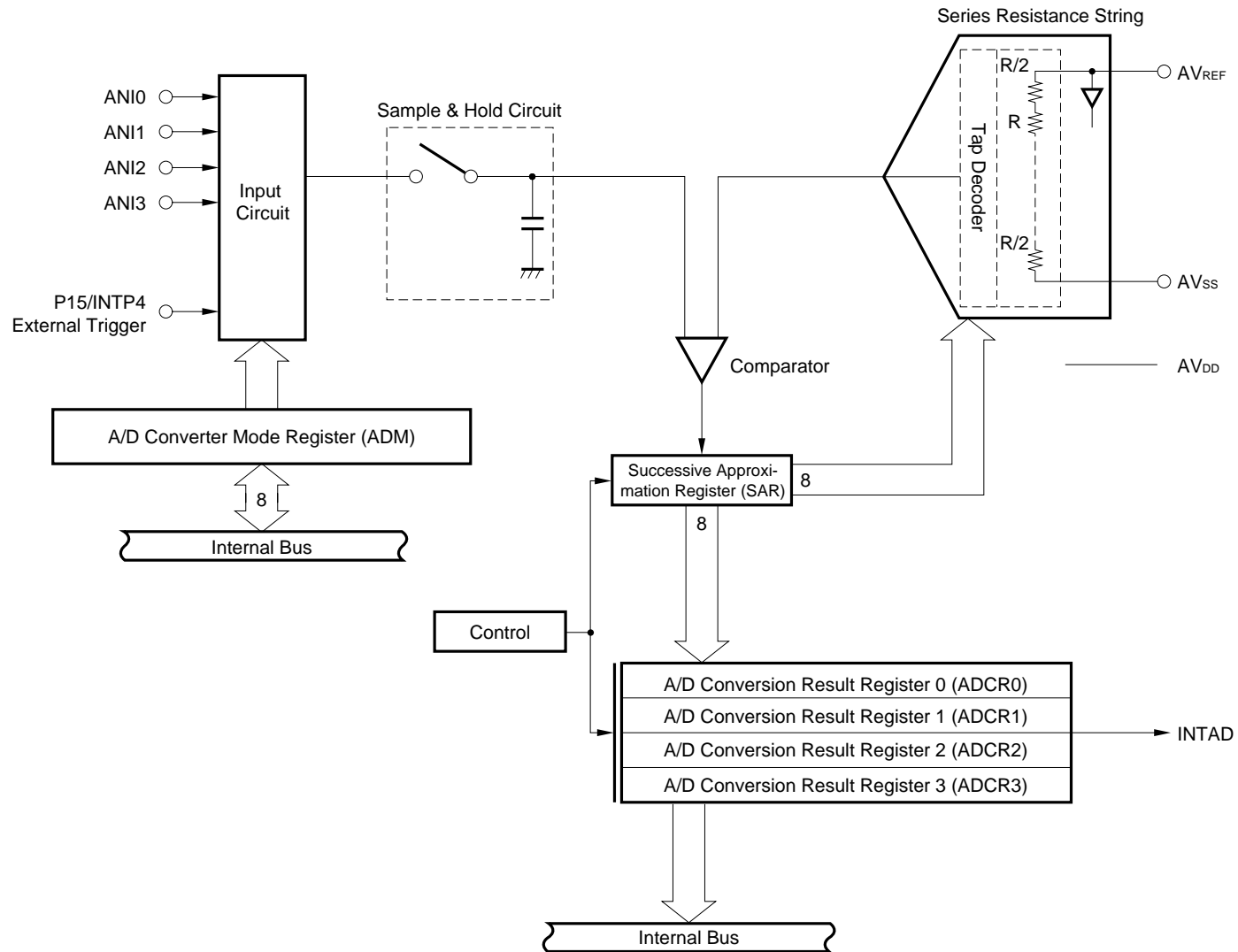

13. STANDBY FUNCTIONS

The V55PI has two methods for controlling the operating clock as standby functions designed to reduce power dissipation. Transition to either of these standby modes is possible by means of a dedicated instruction.

Table 13-1. HALT/STOP Mode Operating Status

Parameter		HALT Mode	STOP Mode
Clock generator		Operating	Stopped
Internal system clock		Stopped	
16-bit timer		Operating	
Watchdog timer			
Hold circuit			
Serial interface			
Parallel interface			
A/D Converter			
Interrupt request controller			
DMA controller			
★ $\overline{\text{IORD}}$, $\overline{\text{IOWR}}$			
Bus lines	AD0 to AD15	Change according to DMAC operating status	Retained
	A16 to A23		
R/W output		High level	High level
Refresh operation		Operating	Stopped
Data retention		All internal data retained (CPU status, RAM contents, etc.)	All internal data retained (CPU status, RAM contents, etc.)
Release method		<ul style="list-style-type: none"> • NMI • INTWDT • $\overline{\text{Maskable}}$ interrupt request • $\overline{\text{RESET}}$ input 	<ul style="list-style-type: none"> • $\overline{\text{NMI}}$ • $\overline{\text{RESET}}$ input

13.1 HALT MODE

In this mode, the CPU operating clock is halted.

Setting the CPU idle time to the HALT mode enables overall system power dissipation to be reduced. The HALT mode is entered by executing the HALT instruction.

In the HALT mode the CPU clock and program execution are stopped, and all register and on-chip RAM contents immediately prior to the stoppage are retained. The status of each hardware unit is shown in Table 13-1.

When the HALT instruction is executed during a DMA transfer, transition to the HALT mode is deferred until the transfer bus cycle for one DMA request is completed.

13.2 STOP MODE

In this mode, clock oscillation is stopped.

This is effective when the entire application system is stopped, and offers extremely low power dissipation. The STOP mode is entered by executing the STOP instruction. In this mode all clocks are stopped. Program execution is stopped, and all register and on-chip RAM contents immediately prior to the stoppage are retained. The status of each hardware unit is shown in Table 13-1.

When the STOP instruction is executed during a DMA transfer, transition to the STOP mode is deferred until the transfer bus cycle for one DMA request is completed. If there is contention between a refresh cycle and STOP instruction execution, transition to the STOP mode is deferred until the refresh cycle is completed.

14. CLOCK GENERATOR

The clock generator supplies various clocks to the CPU and peripheral hardware, and controls the CPU operating mode.

14.1 CLOCK GENERATOR CONFIGURATION AND OPERATION

The clock generator is configured as shown in Figure 14-1.

The clock generator clock is generated by a crystal resonator or ceramic resonator connected to the X1 and X2 pins. The clock generator output is subjected to waveform shaping (dividing frequency by 2) and selection of the scaling factor by means of the processor control register (PRC), and is then used as the system clock ϕ .

The system clock ϕ scaling factor is specified by the PCK1 and PCK0 bits of the PRC register, and can be selected as 1/2, 1/4, 1/8 or 1/16 the oscillator frequency (f_{xx}).

Selecting a low-speed system clock ϕ reduces the current consumption of internal circuit, allowing extended operation of a battery-driven system even when the voltage drops.

An external clock can be input. In this case, the clock signal should be input to the X1 pin, and leave the X2 pin open.

Figure 14-1. Clock Generator

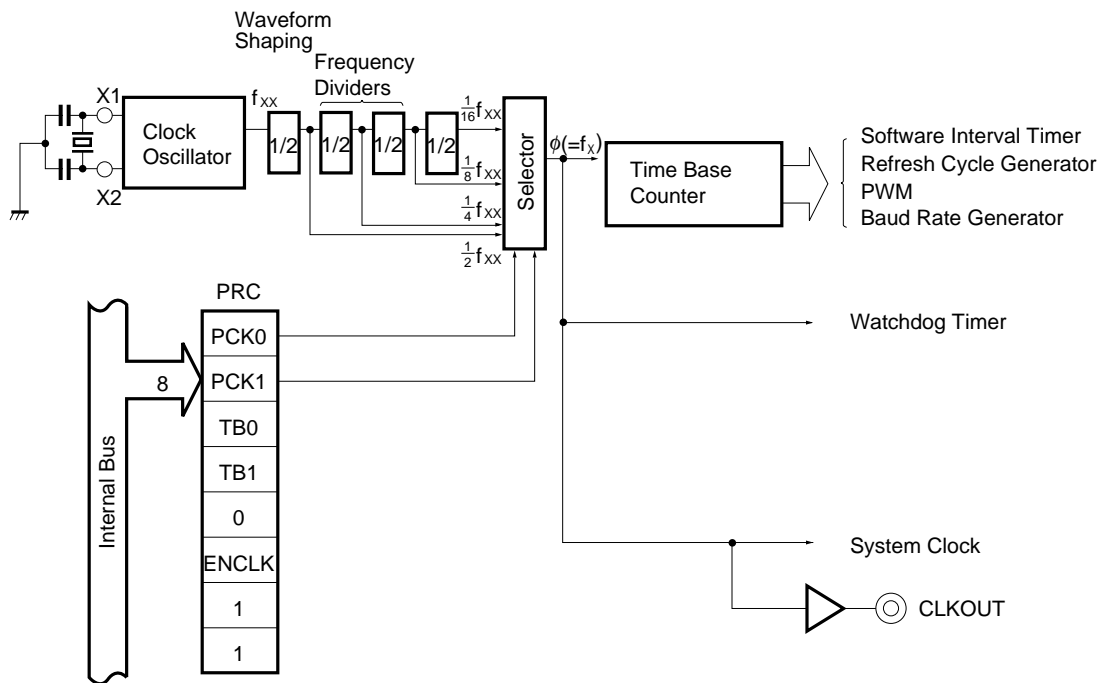

- f_{xx} : Oscillator frequency
- ϕ : System clock
- PRC: Processor control register

In the V55PI, the frequency divider (time base counter: TBC) which divides the internal system clock ϕ is shared by each timer unit.

The TBC cannot be read or written to by an instruction.

The TBC tap output (divide-by- 2^n clock) is supplied to the units shown below as a count clock.

- (1) Refresh cycle generator
- (2) Software interval timer
- (3) PWM unit
- (4) Baud rate generator

The TBC is cleared to 00H only by reset input, after which it is constantly incremented. TBC operation is stopped in the STOP mode. The configuration of the TBC is shown in Figure 14-2.

Figure 14-2. Frequency Divider (Time Base Counter, TBC) Configuration

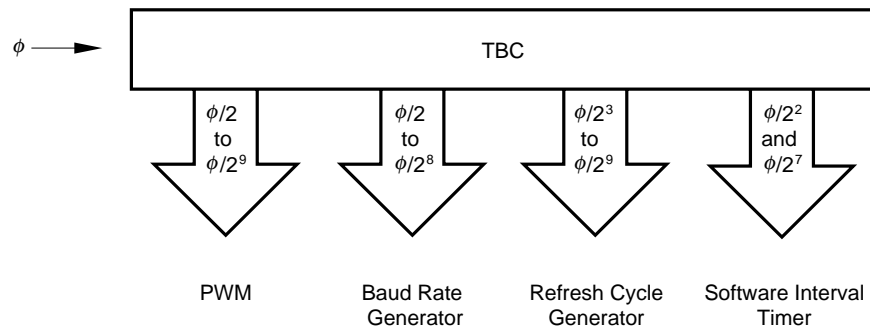

15. SOFTWARE INTERVAL TIMER FUNCTION

The V55PI incorporates a 16-bit software interval timer as a timer for software timer functions and watch functions.

15.1 SOFTWARE INTERVAL TIMER CONFIGURATION

The configuration of the software interval timer is shown in Figure 15-1.

Figure 15-1. Software Interval Timer Configuration

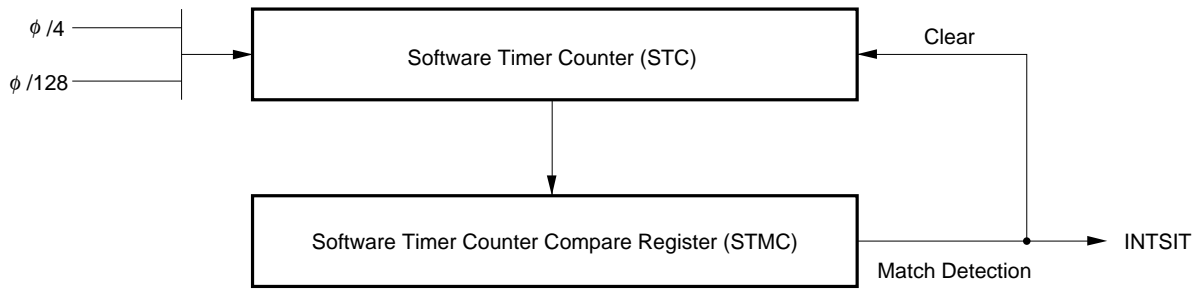

16. CODEC INSTRUCTIONS

The V55PI has 9 codec instructions.

Using these special instructions on the V55PI enables not only image information MH encoding but also MR encoding which previously required the use of a special device such as an ACEE (advanced compression/expansion engine) to be implemented by means of a small-scale, high-speed codec.

16.1 FEATURES

The V55PI has the following 9 codec instructions (4 for compression, 5 for expansion):

- Compression instructions
 - (1) Change point table creation instruction: COLTRP
 - (2) Data transmission instruction (transmission of EOL *1, FILL, RTC *2, etc.): ALBIT
 - (3) MH encoding instruction: MHENC
 - (4) MR encoding instruction: MRENC
- Expansion instructions
 - (5) EOL detection instruction: SCHEOL
 - (6) 1-bit (tag) detection instruction: GETBIT
 - (7) MH decoding change point table creation instruction: MHDEC
 - (8) MR decoding change point table creation instruction: MRDEC
 - (9) Pixel data creation instruction: CNVTRP

MH/MR encoding and MH/MR decoding using these instructions are performed as shown in Figures 16-1 and 16-2.

- * 1. EOL: End Of Line
- 2. RTC: Return To Control

Note When compression/expansion processing is performed using the V55PI codec instructions, the following should be specified as preconditions.

- Compression/expansion is to be performed line by line.
- Consideration must be given to task switching and interrupt generation during compression processing.
- The number of bits processed per line must not be changed during processing of one page.
- The segment value must be changed for data over 64 Kbytes that straddles segments during processing.

Figure 16-1. MH/MR Encoding Processing Flow

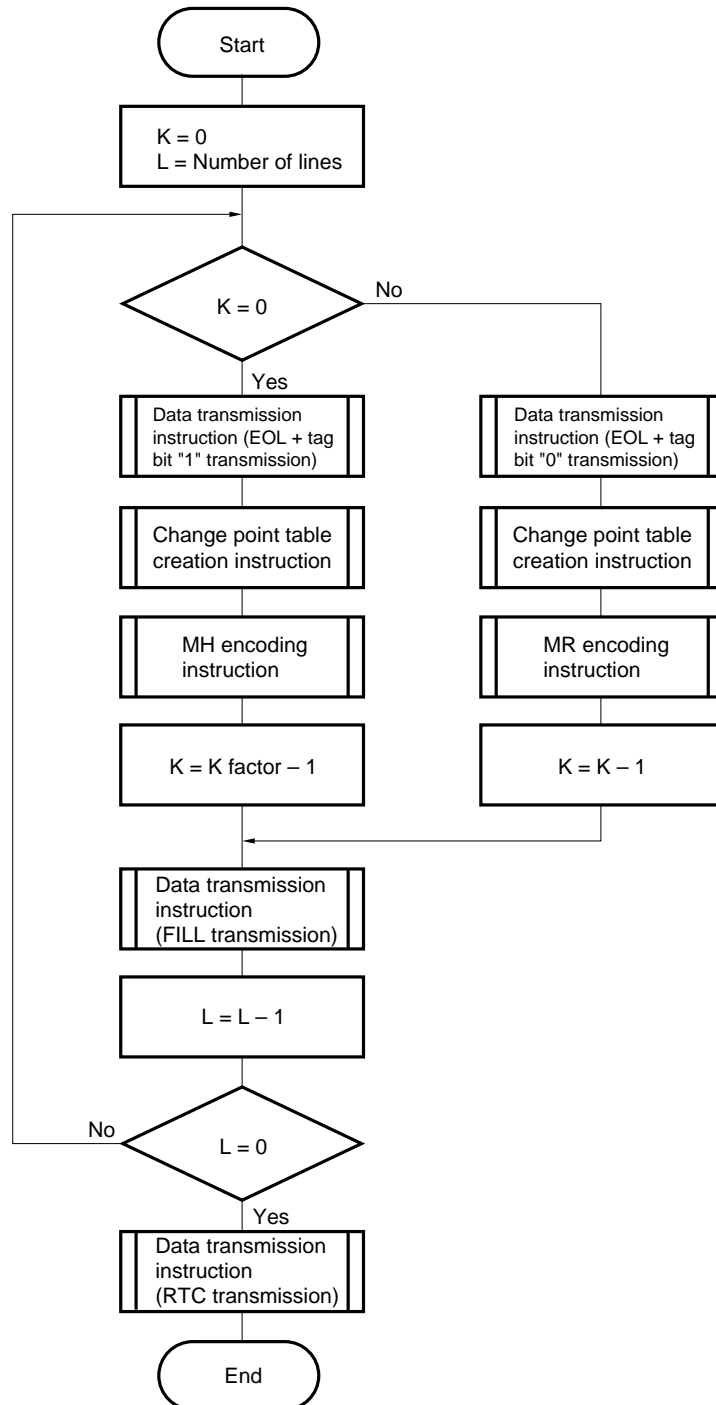
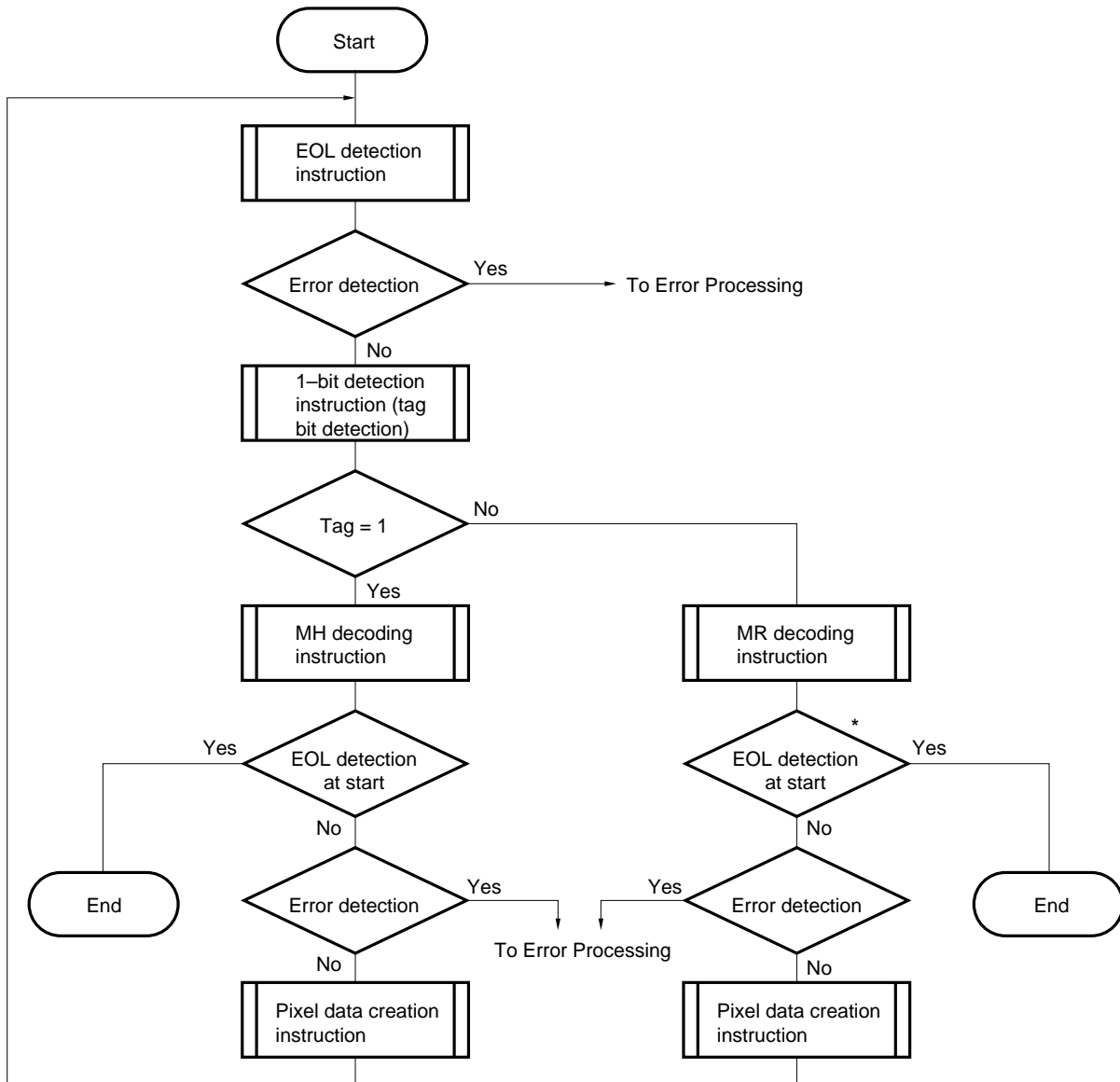

Figure 16-2. MH and MR Decoding Processing Flow



* RTC is detected by two EOLs.

16.2 MEMORY MAP

The data memory areas required by the V55PI's codec instructions are shown below.

(1) Register file space

This is the register bank for parameter setting.

(2) User RAM

Encoding line change point table : Storage area for change point information required for performing encoding
 In the case of n bit/lines, a maximum area of 2n + 4 bytes is required.

Reference line table : Reference line change point information storage area

Image data buffer : Storage area for pixel data read from scanner in encoding, or encoding data received from modem in decoding

Transmit/receive buffer : Buffer for transferring encoded data to modem/scanner

Print buffer : Buffer for transferring decoded pixel data to recording system

(3) User ROM

Encoding conversion table : Conversion table for MH/MR encoding

Decoding conversion table : Conversion table for MH/MR decoding

(4) Access to Expanded Memory Space

The 16-Mbyte expanded memory space can be accessed by using the expanded segment override prefix instruction (DS2: or DS3:).

However, the segment registers DS2 and DS3 that are used during instruction execution are DS2 and DS3 in the parameter setting register banks of each instruction.

Table 16-1. Instructions to which Expanded Segment Override Prefix Can Be Attached

DS2:	DS3:	CODEC Instruction
Yes	Yes	COLTRP
Yes	No	MHENC
Yes	Yes	MHDEC
Yes	No	MRENC
Yes	Yes	MRDEC
Yes	No	SCHEOL
Yes	No	GETBIT
Yes	Yes	CNVTRP

Example

DS2 : DS3 : COLTRP

DS2 : SCHEOL

The relationship between encoding instructions and data in memory is shown in Figure 16-3, and the relationship between decoding instruction and data in memory is shown in Figure 16-4.

Figure 16-3. Encoding Instructions and Data in Memory

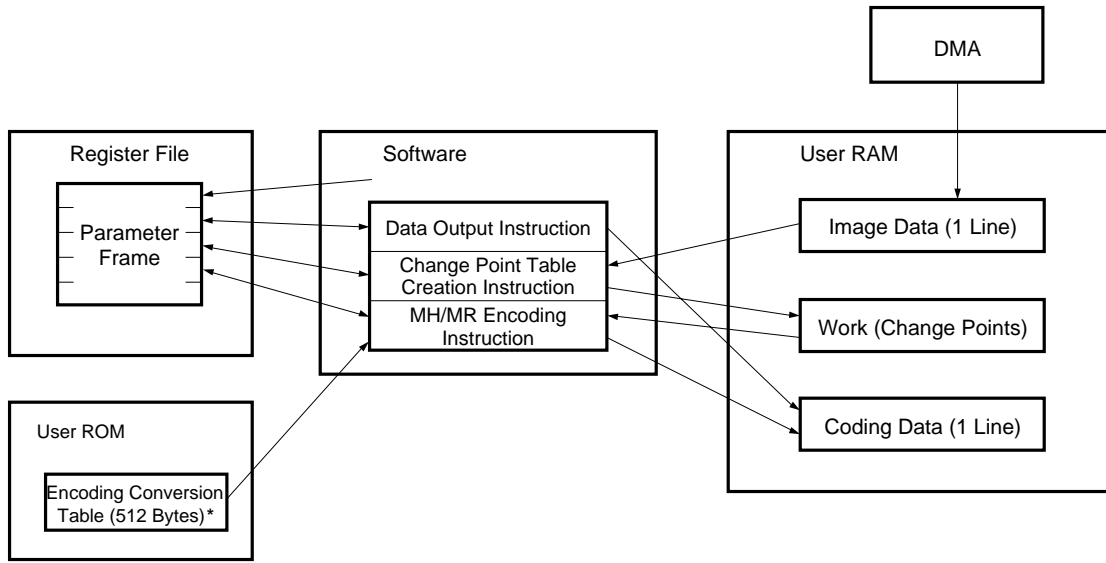

* In case of MH/MR encoding instructions

Figure 16-4. Decoding Instruction and Data in Memory

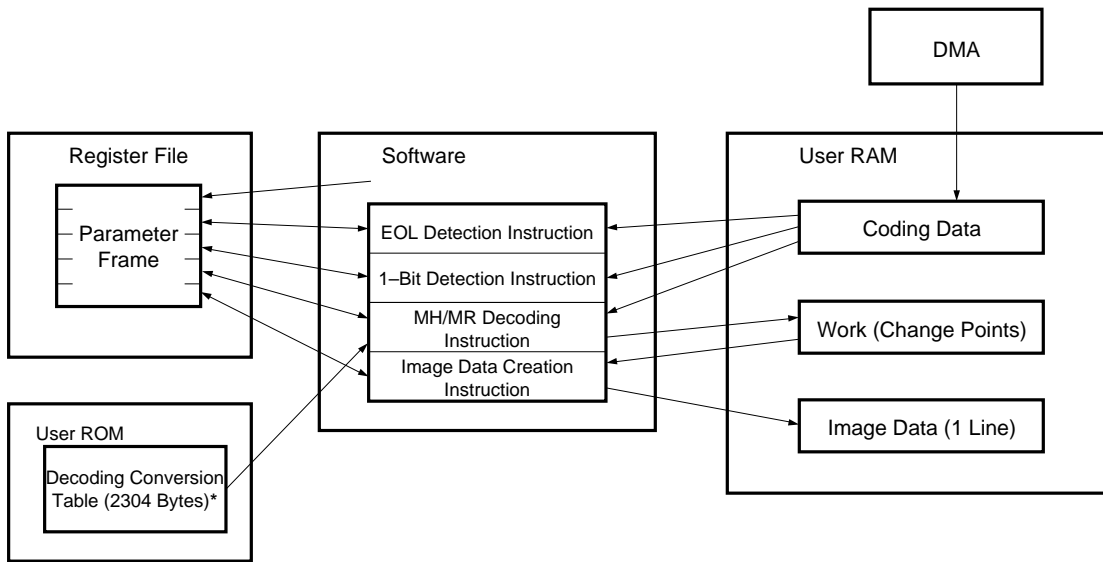

* In case of MH/MR decoding instructions

16.3 PROCESSING FLOW

The instructions shown in 16.1 "Features" are used in the order shown in Figures 16-5 and 16-6 in encoding/decoding processing.

Figure 16-5. Processing Flow for Encoding of One Line

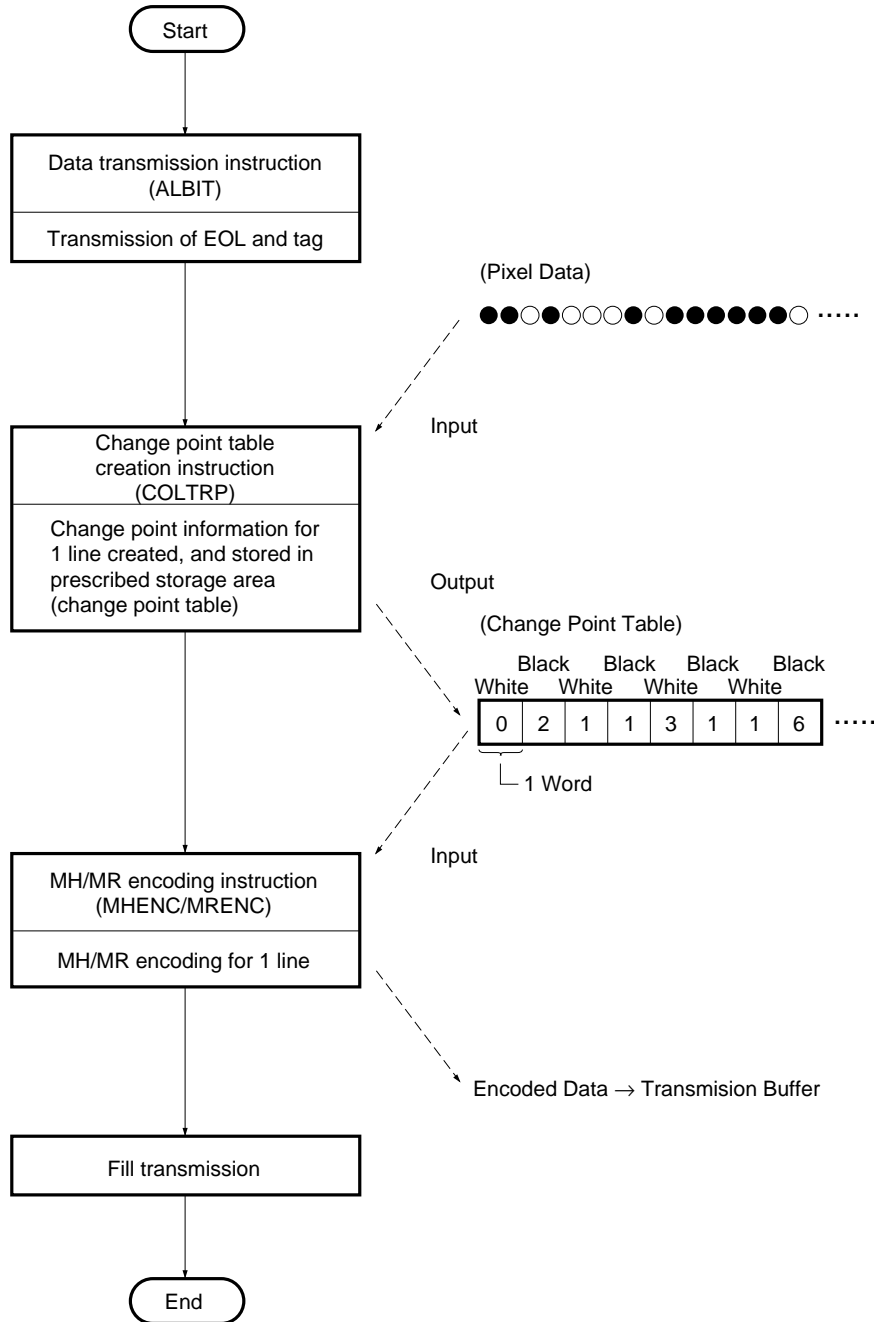
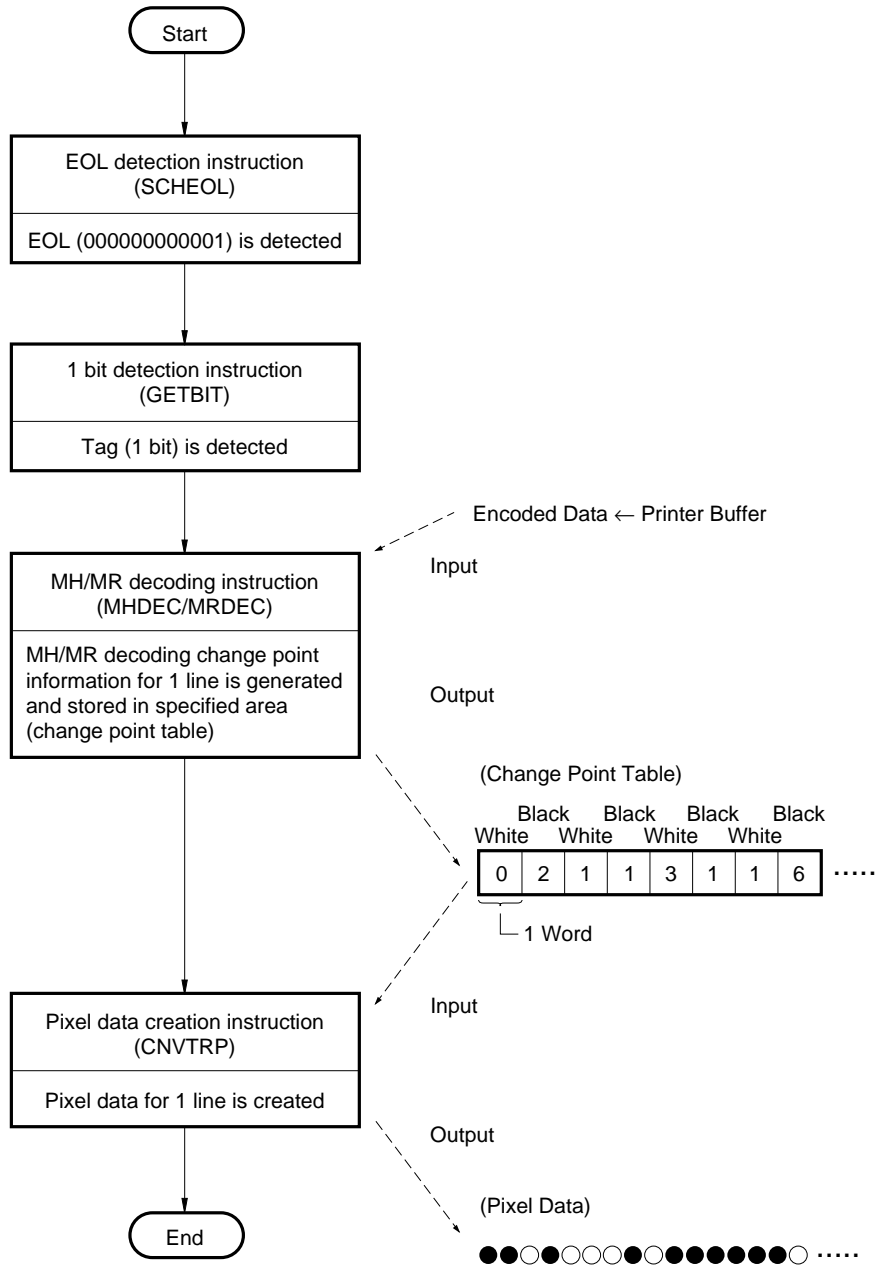

Figure 16-6. Processing Flow for Decoding of One Line



17. INSTRUCTION SET

The V55PI instruction set is upward compatible with the V20/V30 (native mode) and V25/V35 instruction sets.

17.1 INSTRUCTIONS NEWLY ADDED TO V20/V30 AND V25/V35

Instructions which have been added to the V20/V30 and V25/V35 instruction sets, and instructions whose application range has been extended, are shown below.

(1) Instructions added to V20/V30.

Mnemonic	Operand	Instruction Group
BRKCS	reg 16	Register bank switching instruction
TSKSW	reg 16	
MOVSPA	None	Data transfer instruction
MOVSPB	reg 16	
BTCLR	sfr, imm3, short-label	Conditional branch instruction
RETRBI	None	Interrupt instruction
FINT	None	
STOP	None	CPU control instruction

(2) Instructions added to V25/V35.

Mnemonic	Operand	Instruction Group
IRAM	None	Register file space access override prefix instruction
DS2	None	Extended segment override prefix instruction
DS3	None	
MOV	DS2, reg16, mem32	Data transfer instruction
	DS3, reg16, mem32	
	xsreg, reg16	
	xsreg, mem16	
	reg16, xsreg	
	mem16, xsreg	
PUSH	DS2	Stack manipulation instruction
	DS3/VPC	
POP	DS2	
	DS3/VPC	
RSTWDT	imm8, imm8'	Watchdog timer manipulation instruction
BTCLRL	sfrl, imm3, short-label	Conditional branch instruction
BSCH	reg8	Bit manipulation instruction
	mem8	
	reg16	
	mem16	
QHOUT	imm16	Queue manipulation instruction
QOUT	imm16	
QTIN	imm16	
ALBIT	None	Dedicated FAX instruction
COLTRP	None	
MHENC	None	
MRENC	None	
SCHEOL	None	
GETBIT	None	
MHDEC	None	
MRDEC	None	
CNVTRP	None	

Remark VPC: Vector PC

17.2 INSTRUCTION SET OPERATIONS

Table 17-1. Operand Type Legend

Identifier	Description
reg,	8/16-bit general register (Destination register in an instruction using two 8/16-bit general registers)
reg'	Source register in an instruction using two 8/16-bit general registers
reg8,	8-bit general register (Destination register in an instruction using two 8-bit general registers)
reg8'	Source register in an instruction using two 8-bit general registers
reg16,	16-bit general register (Destination register in an instruction using two 16-bit general registers)
reg16'	Source register in an instruction using two 16-bit general registers
mem	8/16-bit memory address
mem8	8-bit memory address
mem16	16-bit memory address
mem32	32-bit memory address
sfr	Special function register location: FFF00H to FFFEFH
sfrl	Special function register location: FFE00H to FFEFFH
dmem	16-bit direct memory address
imm	8/16-bit immediate data
imm3	3-bit immediate data
imm4	4-bit immediate data
imm8	8-bit immediate data
imm8'	8-bit immediate data (1's compliment of imm8)
imm16	16-bit immediate data
acc	Accumulator AW or AL
sreg	Segment register
xsgreg	Extended segment register
src-table	Name of 256-byte conversion table
src-block	Name of source block addressed by register IX
dst-block	Name of destination block addressed by register IY
src-string	Name of source string addressed by register IX
dst-string	Name of destination string addressed by register IY
near-proc	Procedure start address in current program segment
far-proc	Procedure start address in a different program segment
near-label	Absolute address in current program segment
short-label	Relative address of memory in range -128 to +127 bytes from end of instruction
far-label	Absolute address in a different program segment
regptr16	16-bit general register holding call address offset in current program segment
memptr16	16-bit memory address holding call address offset in current program segment
memptr32	32-bit memory address holding call address offset and segment data in a different program segment
pop-value	Number of bytes removed from stack (0 to 64K, normally an even number)
fp-op	Immediate value which identifies external floating point operation coprocessor operation code
repeat	Repeat prefix instruction
IRAM :	Register file space access override prefix instruction
R	Register set (AW, BW, CW, DW, SP, BP, IX, IY)
()	Omissible
or, /	Or

Table 17-2. Operation Code Legend

Identifier	Description
W	Word/byte specification bit (1: word, 0: byte). However, when s = 1, sign extension byte data is specified as 16-bit operand even if W = 1.
reg, reg'	8/16-bit general register specification bits (000 to 111)
mod, mem	Memory addressing specification bits (mod: 00 to 10, mem: 000 to 111)
(disp-low)	Optional 16-bit displacement low byte
(disp-high)	Optional 16-bit displacement high byte
disp-low	16-bit displacement low byte for PC relative addition
disp-high	16-bit displacement high byte for PC relative addition
imm3	3-bit immediate data
imm4	4-bit immediate data
imm8	8-bit immediate data
imm8'	8-bit immediate data (1's complement of imm8)
imm16-low	16-bit immediate data low byte
imm16-high	16-bit immediate data high byte
addr-low	16-bit direct address low byte
addr-high	16-bit direct address high byte
sreg	Segment register specification bits (00 to 11)
xsreg	Extended segment register specification bits (10 to 11)
s	Sign extension specification bit (1: sign extension, 0: no sign extension)
offset-low	Low byte of 16-bit offset data to be loaded in PC
offset-high	High byte of 16-bit offset data to be loaded in PC
seg-low	Low byte of 16-bit segment data to be loaded in PS
seg-high	High byte of 16-bit segment data to be loaded in PS
pop-value-low	Low byte of 16-bit data which specifies number of bytes to be removed from stack
pop-value-high	High byte of 16-bit data which specifies number of bytes to be removed from stack
disp8	8-bit displacement for relative addition to PC
X	} Operation code of an external floating point operation coprocessor
XXX	
YYY	
ZZZ	

Table 17-3. Operation Description Legend

Identifier	Description
AW	Accumulator (16 bits)
AH	Accumulator (high byte)
AL	Accumulator (low byte)
BW	Register BW (16 bits)
CW	Register CW (16 bits)
CL	Register CL (low byte)
DW	Register DW
SP	Stack pointer (16 bits)
BP	Base Pointer (16 bits)
PC	Program counter (16 bits)
PSW	Program status word (16 bits)
IX	Index register (source) (16 bits)
IY	Index register (destination) (16 bits)
PS	Program segment register (16 bits)
DS3	Extended data segment 3 register (16 bits)
DS2	Extended data segment 2 register (16 bits)
DS1	Data segment 1 register (16 bits)
DS0	Data segment 0 register (16 bits)
SS	Stack segment register (16 bits)
AC	Auxiliary carry flag
CY	Carry flag
P	Parity flag
S	Sign flag
Z	Direction flag
IE	Interrupt enable flag
V	Overflow flag
IBRK	I/O break flag
BRK	Break flag
RB0	Register bank 0 flag
RB1	Register bank 1 flag
RB2	Register bank 2 flag
RB3	Register bank 3 flag
VPC	Vector PC
(...)	Contents of memory indicated by contents of in parenthesis
disp	Displacement (8/16-bit)
temp	Temporary register (8/16/32 bits)
ext-disp8	16 bits with 8-bit displacement sign-extended
seg	Immediate segment data (16 bits)
offset	Immediate offset data (16 bits)
←	Transfer direction
+	Addition
-	Subtraction
×	Multiplication
÷	Division
%	Modulo
^	Logical product (AND)
∨	Logical sum (OR)
⊕	Exclusive logical sum (exclusive OR)
xxH	2-digit hexadecimal number
xxxxH	4-digit hexadecimal number
/	Alternate function, or

Table 17-4. Flag Operation Legend

Identifier	Description
(Blank)	No change
0	Cleared to 0
1	Set to 1
×	Set or cleared depending on result
U	Undefined
R	Previously saved value is restored

Table 17-5. Memory Addressing

mem \ mod	00	01	10
000	BW + IX	BW + IX + disp8	BW + IX + disp16
001	BW + IY	BW + IY + disp8	BW + IY + disp16
010	BP + IX	BP + IX + disp8	BP + IX + disp16
011	BP + IY	BP + IY + disp8	BP + IY + disp16
100	IX	IX + disp8	IX + disp16
101	IY	IY + disp8	IY + disp16
110	Direct address	BP + disp8	BP + disp16
111	BW	BW + disp8	BW + disp16

Note When BP is used in memory addressing other than in a primitive instruction, the default segment register is SS. When BP is not used, the default segment register is DS0. In primitive instruction memory addressing, the destination block default segment register is DS1. In memory addressing, the source block default segment register is DS0.

Table 17-6. 8/16-Bit General Register Selection

reg	W = 0	W = 1
000	AL	AW
001	CL	CW
010	DL	DW
011	BL	BW
100	AH	SP
101	CH	BP
110	DH	IX
111	BH	IY

Table 17-7. Segment Register Selection

sreg	
00	DS1
01	PS
10	SS
11	DS0

Table 17-8. Extended Segment Register Selection

xsreg	
10	DS3/VPC
11	DS2

Number of Clock Cycles

In the case of a memory operand the number of clock cycles depends on the addressing mode. The following numbers should be used for “EA” in **Table 17-9 “Number of Clock Cycles”**.

mod mem	00	Clock Cycles	01	Clock Cycles	10	Clock Cycles
	000	BW + IX	3	BW + IX + disp8	3	BW + IX + disp16
001	BW + IY	3	BW + IY + disp8	3	BW + IY + disp16	3
010	BP + IX	3	BP + IX + disp8	3	BP + IX + disp16	3
011	BP + IY	3	BP + IY + disp8	3	BP + IY + disp16	3
100	IX	2	IX + disp8	2	IX + disp16	2
101	IY	2	IY + disp8	2	IY + disp16	2
110	Direct address	2	BP + disp8	2	BP + disp16	2
111	BW	2	BW + disp8	2	BW + disp16	2

“T” indicates the number of wait states. Any number of wait states from "0" (no wait) up can be used.

Table 17-9. Number of Clock Cycles (1/20)

Instruction Group	Mnemonic	Operands	Bus Width*	Byte Processing		Word Processing		
				On-Chip RAM Access	Other Access	On-Chip RAM Access	Other Access	
Data transfer instructions	MOV	reg, reg'	—	2	2	2	2	
		mem, reg	—	EA + 2	EA + 3	EA + 2	EA + 3	
		reg, mem	8	EA + 2	EA + 5 + T	EA + 2	EA + 8 + 2T	
			16				EA + 5 + T	
		mem, imm	—	EA + 2	EA + 3	EA + 2	EA + 3	
		reg, imm	—	2	2	2	2	
		acc, dmem	8	4	7 + T	4	10 + 2T	
			16				7 + T	
		dmem, acc	—	4	5	4	5	
		sreg, reg16	—	—	—	2	2	
		xsreg, reg16 VPC, reg16	8	—	—	2	2	
			16				2	
		sreg, mem16	8	—	—	EA + 2	EA + 8 + 2T	
			16				EA + 5 + T	
		xsreg, mem16/ VPC, mem16	8	—	—	EA + 2	EA + 8 + 2T	
			16				EA + 5 + T	
		reg16, sreg	—	—	—	2	2	
		reg16, xsreg/ reg16, VPC	8	—	—	2	2	
			16				2	
		mem16, sreg	—	—	—	EA + 2	EA + 3	
		mem16, xsreg/ mem16, VPC	8	—	—	EA + 2	EA + 3	
			16				EA + 3	
		DS0, reg16, mem32	8	—	—	EA + 5	EA + 17 + 4T	
			16				EA + 11 + 2T	
DS2, reg16, mem32	8	—	—	EA + 5	EA + 17 + 4T			
	16				EA + 11 + 2T			
DS1, reg16, mem32	8	—	—	EA + 5	EA + 17 + 4T			
	16				EA + 11 + 2T			
DS3, reg16, mem32	8	—	—	EA + 5	EA + 17 + 4T			
	16				EA + 11 + 2T			

* 8 : 8-bit width 16 : 16-bit width — : Both 8-bit and 16-bit bus width

Table 17-9. Number of Clock Cycles (2/20)

Instruction Group	Mnemonic	Operands	Bus Width*	Byte Processing		Word Processing		
				On-Chip RAM Access	Other Access	On-Chip RAM Access	Other Access	
Data transfer instructions	MOV	AH, PSW	—	2	2	—	—	
		PSW, AH	8	3	3	—	—	
			16	2	2	—	—	
	LDEA	reg16, mem16	—	—	—	EA + 2	EA + 2	
	TRANS/ TRANSB	src-table	—	6	9 + T	—	—	
	XCH	reg, reg'	—	—	4	4	4	4
		mem, reg/ reg, mem	—	EA + 4	EA + 7 + T	EA + 4	EA + 10 + 2T	
			—	—	—	—	EA + 7 + T	
AW, reg16/ reg16, AW	—	—	—	—	4	4		
MOVSPA		—	—	—	8	8		
MOVSPB	reg16	—	—	—	9	9		
Repeat prefixes	REPC		—	0 to 1	0 to 1	0 to 1	0 to 1	
	REPNC		—	0 to 1	0 to 1	0 to 1	0 to 1	
	REP/ REPE/ REPZ		—	0 to 1	0 to 1	0 to 1	0 to 1	
	REPNE/ REPZ		—	0 to 1	0 to 1	0 to 1	0 to 1	
Primitive block transfer instructions	MOVBK	dst-block, src-block	8	18 + T	19 + T	21 + 2T	22 + 2T	
				(rep) 9 + (11 + T)n	9 + (12 + 2T)n	9 + (14 + 2T)n	9 + (18 + 4T)n	
	MOVBKB/ MOVBKW		16	(rep CW = 0)	5	18 + T	19 + T	
				5	5	9 + (11 + T)n	9 + (12 + 2T)n	
	CMPBK	src-block, dst-block	8	20 + T	22 + 2T	23 + 2T	28 + 4T	
				(rep) 9 + (13 + T)n	9 + (15 + 2T)n	9 + (16 + 2T)n	9 + (21 + 4T)n	
	CMPBKB/ CMPBKW		16	(rep CW = 0)	5	20 + T	22 + 2T	
				5	5	9 + (13 + T)n	9 + (15 + 2T)n	

* 8 : 8-bit width
 16 : 16-bit width
 — : Both 8-bit and 16-bit bus width

Remark n: Number of repetitions

Table 17-9. Number of Clock Cycles (3/20)

Instruction Group	Mnemonic	Operands	Bus Width*	Byte Processing		Word Processing	
				On-Chip RAM Access	Other Access	On-Chip RAM Access	Other Access
Primitive block transfer instructions	CMPM	dst-block	8	15	17 + T	15	20 + T
	CMPMB/ CMPMW			(rep)	10 + 7n		10 + (9 + T)n
			(rep CW = 0)	5	5	5	5
			16	17 + T	10 + (9 + T)n	5	
			5				
	LDM	src-block	8	10	13 + T	10	16 + T
	LDMB/ LDMW			(rep)	9 + 3n		9 + (6 + T)n
			(rep CW = 0)	5	5	5	5
			16	13 + T	9 + (6 + T)n	5	
			5				
	STM	dst-block	8	12	13	12	13
	STMB/ STMW			(rep)	9 + 5n		9 + (6 + T)n
(rep CW = 0)			5	5	5	5	
16			13	9 + (6 + T)n	5		
5							
Bit field manipulation instructions	INS	reg8, reg8'	8	—	—	22 to 63	31 to 72
			16				23 to 64
		reg8, imm4	8	—	—	22 to 63	31 to 72
			16				23 to 64
	EXT	reg8, reg8'	8	—	—	19 to 41	19 + 2T to 48 + 4T
			16				19 to 42 + 2T
		reg8, imm4	8	—	—	19 to 41	19 + 2T to 48 + 4T
			16				19 to 42 + 2T

* 8 : 8-bit width
 16 : 16-bit width
 — : Both 8-bit and 16-bit bus width

Remark n: Number of repetitions

Table 17-9. Number of Clock Cycles (4/20)

Instruction Group	Mnemonic	Operands	Bus Width *1	Byte Processing		Word Processing		
				On-Chip RAM Access	Other Access	On-Chip RAM Access	Other Access	
Input/output instructions	IN*2	acc8, imm8	8	—	7 + T	—	10 + 2T	
			16				7 + T	
		acc, DW	8	—	7 + T	—	10 + 2T	
			16				7 + T	
	OUT*2	imm8, acc	8	—	5	—	5	
			16				5	
		DW, acc	8	—	5	—	5	
			16				5	
Primitive input/output instructions	INM*2	dst-block, DW	8	17 + T	18 + T	20 + 2T	21 + 2T	
				-----		9 + (13 + 2T)n	9 + (17 + 4T)n	
				(rep) 9 + (10 + T)n	9 + (11 + 2T)n	5	5	
			16	(rep CW = 0)	5	5	17 + T	18 + T
				-----		9 + (10 + T)n	9 + (11 + 2T)n	
				5	5	5	5	
	OUTM*2	DW, src-block	8	14 + T	17 + 2T	17 + 2T	23 + 4T	
				-----		9 + (10 + 2T)n	9 + (16 + 4T)n	
				(rep) 9 + (7 + T)n	9 + (10 + 2T)n	5	5	
			16	(rep CW = 0)	5	5	14 + T	17 + 2T
				-----		9 + (7 + T)n	9 + (10 + 2T)n	
				5	5	5	5	

* 1. 8 : 8-bit width
 16 : 16-bit width
 2. When $\overline{IBRK} = 1$. As shown in the next page when $\overline{IBRK} = 0$.

Remark n: Number of repetitions

Table 17-9. Number of Clock Cycles (5/20)

Instruction Group	Mnemonic	Operands	Bus Width*	Byte Processing		Word Processing	
				On-Chip RAM Access	Other Access	On-Chip RAM Access	Other Access
Input/output instructions	IN	acc8, imm8	8	—	60 + 10T	—	60 + 10T
			16		40 + 5T		40 + 5T
		acc, DW	8	—	60 + 10T	—	60 + 10T
			16		40 + 5T		40 + 5T
	OUT	imm8, acc	8	—	60 + 10T	—	60 + 10T
			16		40 + 5T		40 + 5T
		DW, acc	8	—	60 + 10T	—	60 + 10T
			16		40 + 5T		40 + 5T
Primitive input/output instructions	INM	dst-block, DW	8	—	60 + 10T	—	60 + 10T
			16		40 + 5T		40 + 5T
	OUTM	DW, src-block	8	—	60 + 10T	—	60 + 10T
			16		40 + 5T		40 + 5T

* 8 : 8-bit width
 16 : 16-bit width

Table 17-9. Number of Clock Cycles (6/20)

Instruction Group	Mnemonic	Operands	Bus Width*	Byte Processing		Word Processing	
				On-Chip RAM Access	Other Access	On-Chip RAM Access	Other Access
Addition/subtraction instructions	ADD	reg, reg'	—	3	3	3	3
		mem, reg	8	EA + 4	EA + 7 + T	EA + 4	EA + 10 + 2T
			16				EA + 7 + T
		reg, mem	8	EA + 2	EA + 6 + T	EA + 2	EA + 9 + 2T
			16				EA + 6 + T
		reg, imm	—	2	2	2	2
		mem, imm	8	EA + 4	EA + 7 + T	EA + 4	EA + 10 + 2T
	16		EA + 7 + T				
	acc, imm	—	2	2	2	2	
	ADDC	reg, reg'	—	3	3	3	3
		mem, reg	8	EA + 4	EA + 7 + T	EA + 4	EA + 10 + 2T
			16				EA + 7 + T
		reg, mem	8	EA + 2	EA + 6 + T	EA + 2	EA + 9 + 2T
			16				EA + 6 + T
		reg, imm	—	2	2	2	2
		mem, imm	8	EA + 4	EA + 7 + T	EA + 4	EA + 10 + 2T
	16		EA + 7 + T				
	acc, imm	—	2	2	2	2	
	SUB	reg, reg'	—	3	3	3	3
		mem, reg	8	EA + 4	EA + 7 + T	EA + 4	EA + 10 + 2T
			16				EA + 7 + T
reg, mem		8	EA + 2	EA + 6 + T	EA + 2	EA + 9 + 2T	
		16				EA + 6 + T	
reg, imm		—	2	2	2	2	
mem, imm		8	EA + 4	EA + 7 + T	EA + 4	EA + 10 + 2T	
	16	EA + 7 + T					
acc, imm	—	2	2	2	2		

* 8 : 8-bit width
 16 : 16-bit width
 — : Both 8-bit and 16-bit bus width

Table 17-9. Number of Clock Cycles (7/20)

Instruction Group	Mnemonic	Operands	Bus Width*	Byte Processing		Word Processing	
				On-Chip RAM Access	Other Access	On-Chip RAM Access	Other Access
Addition/subtraction instructions	SUBC	reg, reg'	—	3	3	3	3
		mem, reg	8	EA + 4	EA + 7 + T	EA + 4	EA + 10 + 2T
			16				EA + 7 + T
		reg, mem	8	EA + 2	EA + 6 + T	EA + 2	EA + 9 + 2T
			16				EA + 6 + T
		reg, imm	—	2	2	2	2
		mem, imm	8	EA + 4	EA + 7 + T	EA + 4	EA + 10 + 2T
16					EA + 7 + T		
acc, imm	—	2	2	2	2		
BCD operation instructions	ADD4S	dst-string, src-string	8	6 + (15 + T)n	6 + (19 + 3T)n	—	—
			16				
	SUB4S	dst-string, src-string	8	6 + (16 + T)n	6 + (20 + 3T)n	—	—
			16				
	CMP4S	dst-string, src-string	8	6 + (15 + T)n	6 + (18 + 2T)n	—	—
			16				
ROL4	reg8	8	5	5	—	—	
	mem8	16	EA + 5	EA + 8 + T	—	—	
ROR4	reg8	8	5	5	—	—	
	mem8	16	EA + 5	EA + 8 + T	—	—	
Increment/decrement instructions	INC	reg8	—	2	2	—	—
		mem	8	EA + 3	EA + 7 + T	EA + 3	EA + 10 + 2T
			16				EA + 7 + T
	reg16	—	—	—	2	2	
	DEC	reg8	—	2	2	—	—
		mem	8	EA + 3	EA + 7 + T	EA + 3	EA + 10 + 2T
16						EA + 7 + T	
reg16	—	—	—	2	2		

* 8 : 8-bit width
 16 : 16-bit width
 — : Both 8-bit and 16-bit bus width

Remark n: Half of number of BCD digits

Table 17-9. Number of Clock Cycles (8/20)

Instruction Group	Mnemonic	Operands	Bus Width*	Byte Processing		Word Processing		
				On-Chip RAM Access	Other Access	On-Chip RAM Access	Other Access	
Multiplication instructions	MULU	reg8	—	11	11	15	15	
		mem8	8	EA + 12	EA + 14 + T	EA + 16	EA + 21 + 2T	
			16				EA + 18 + T	
		reg16	—	11	11	15	15	
		mem16	8	EA + 12	EA + 14 + T	EA + 16	EA + 21 + 2T	
			16				EA + 18 + T	
		MUL	reg8	—	10	10	14	14
			mem8	8	EA + 11	EA + 13 + T	EA + 15	EA + 20 + 2T
	16			EA + 17 + T				
	reg16		—	10	10	14	14	
	mem16		8	EA + 11	EA + 13 + T	EA + 15	EA + 20 + 2T	
			16				EA + 17 + T	
	reg16, reg16', imm8/reg16, imm8		—	—	—	14	14	
	reg16, mem16, imm8		8	—	—	EA + 15	EA + 20 + 2T	
16		EA + 17 + T						
reg16, reg16', imm16/reg16, imm16	—	—	—	14	14			
reg16, mem16, imm1616	8	—	—	EA + 15	EA + 20 + 2T			
	16				EA + 17 + T			

* 8 : 8-bit width
 16 : 16-bit width
 — : Both 8-bit and 16-bit bus width

Table 17-9. Number of Clock Cycles (9/20)

Instruction Group	Mnemonic	Operands	Bus Width*	Byte Processing		Word Processing		
				On-Chip RAM Access	Other Access	On-Chip RAM Access	Other Access	
Division instructions	DIVU	reg8	8	15/62 + 10T	15/62 + 10T	23/57 + 10T	23/57 + 10T	
			16	15/42 + 5T	15/42 + 5T	23/42 + 5T	23/42 + 5T	
		mem8	8	EA + 16/63 + 10T	EA + 18 + T/63 + 10T	EA + 24/58 + 10T	EA + 30 + 2T/58 + 10T	
			16	EA + 16/43 + 5T	EA + 18 + T/63 + 5T	EA + 24/43 + 5T	EA + 26 + T/43 + 5T	
		reg16	8	15/62 + 10T	15/62 + 10T	23/57 + 10T	23/57 + 10T	
			16	15/42 + 5T	15/42 + 5T	23/42 + 5T	23/42 + 5T	
		mem16	8	EA + 16/63 + 10T	EA + 18 + T/63 + 10T	EA + 24/58 + 10T	EA + 30 + 2T/58 + 10T	
			16	EA + 16/43 + 5T	EA + 18 + T/43 + 5T	EA + 24/43 + 5T	EA + 26 + T/43 + 5T	
		DIV	reg8	8	17/64 + 10T	17/64 + 10T	25/59 + 10T	25/59 + 10T
				16	17/44 + 5T	17/44 + 5T	25/44 + 5T	25/44 + 5T
			mem8	8	EA + 18/65 + 10T	EA + 20 + T/65 + 10T	EA + 26/60 + 10T	EA + 31 + 2T/60 + 10T
				16	EA + 18/45 + 5T	EA + 20 + T/45 + 5T	EA + 26/45 + 5T	EA + 28 + T/45 + 5T
	reg16		8	17/64 + 10T	17/64 + 10T	25/59 + 10T	25/59 + 10T	
			16	17/44 + 5T	17/44 + 5T	25/44 + 5T	25/44 + 5T	
mem16	8		EA + 18/65 + 10T	EA + 20 + T/65 + 10T	EA + 26/60 + 10T	EA + 31 + 2T/60 + 10T		
	16		EA + 18/45 + 5T	EA + 20 + T/45 + 5T	EA + 26/45 + 5T	EA + 28 + T/45 + 5T		
BCD adjustment instructions	ADJBA	8	6	9	—	—		
		16	9					
	ADJ4A	—	3	3	—	—		
	ADJBS	8	6	6	—	—		
		16	9	9				
ADJ4S	—	3	3	—	—			
Data conversion instructions	CVTBD	—	18	18	—	—		
	CVTDB	—	8	8	—	—		
	CVTBW	—	3	3	—	—		
	CVTWL	—	—	—	3	3		

* 8 : 8-bit width
 16 : 16-bit width
 — : Both 8-bit and 16-bit bus width

Remark Figures on right of / (slash) apply in case of a divide error.

Phase-out/Discontinued

Table 17-9. Number of Clock Cycles (10/20)

Instruction Group	Mnemonic	Operands	Bus Width*	Byte Processing		Word Processing	
				On-Chip RAM Access	Other Access	On-Chip RAM Access	Other Access
Comparison instructions	CMP	reg, reg'	—	3	3	3	3
		mem, reg	8	EA + 4	EA + 6 + T	EA + 4	EA + 9 + 2T
			16				EA + 6 + T
		reg, mem	8	EA + 2	EA + 6 + T	EA + 2	EA + 9 + 2T
			16				EA + 6 + T
		reg, imm	—	2	2	2	2
		mem, imm	8	EA + 4	EA + 6 + T	EA + 4	EA + 9 + 2T
16	EA + 6 + T						
acc, imm	—	2	2	2	2		
Complement operation instructions	NOT	reg	—	2	2	2	2
		mem	8	EA + 3	EA + 7 + T	EA + 3	EA + 10 + 2T
	16		EA + 7 + T				
	NEG	reg	—	2	2	2	2
mem		8	EA + 3	EA + 7 + T	EA + 3	EA + 10 + 2T	
	16	EA + 7 + T					
Logical operation instructions	TEST	reg, reg'	—	3	3	3	3
		mem, reg/ reg, mem	8	EA + 4	EA + 6 + T	EA + 4	EA + 9 + 2T
			16				EA + 6 + T
		reg, imm	—	2	2	2	2
		mem, imm	8	EA + 4	EA + 6 + T	EA + 4	EA + 9 + 2T
	16		EA + 6 + T				
	acc, imm	—	2	2	2	2	
	AND	reg, reg'	—	3	3	3	3
		mem, reg	8	EA + 4	EA + 7 + T	EA + 4	EA + 10 + 2T
			16				EA + 7 + T
		reg, mem	8	EA + 2	EA + 6 + T	EA + 2	EA + 9 + 2T
			16				EA + 6 + T
reg, imm		—	2	2	2	2	
mem, imm	8	EA + 4	EA + 7 + T	EA + 4	EA + 10 + 2T		
	16				EA + 7 + T		
acc, imm	—	2	2	2	2		

* 8 : 8-bit width 16 : 16-bit width — : Both 8-bit and 16-bit bus width

Table 17-9. Number of Clock Cycles (11/20)

Instruction Group	Mnemonic	Operands	Bus Width*	Byte Processing		Word Processing	
				On-Chip RAM Access	Other Access	On-Chip RAM Access	Other Access
Logical operation instructions	OR	reg, reg'	—	3	3	3	3
		mem, reg	8	EA + 4	EA + 7 + T	EA + 4	EA + 10 + 2T
			16				EA + 7 + T
		reg, mem	8	EA + 2	EA + 6 + T	EA + 2	EA + 9 + 2T
			16				EA + 6 + T
		reg, imm	—	2	2	2	2
	mem, imm	8	EA + 4	EA + 7 + T	EA + 4	EA + 10 + 2T	
		16				EA + 7 + T	
	acc, imm	—	2	2	2	2	
	XOR	reg, reg'	—	3	3	3	3
		mem, reg	8	EA + 4	EA + 7 + T	EA + 4	EA + 10 + 2T
			16				EA + 7 + T
reg, mem		8	EA + 2	EA + 6 + T	EA + 2	EA + 9 + 2T	
		16				EA + 6 + T	
reg, imm		—	2	2	2	2	
mem, imm	8	EA + 4	EA + 7 + T	EA + 4	EA + 10 + 2T		
	16				EA + 7 + T		
acc, imm	—	2	2	2	2		
Bit manipulation instructions	TEST1	reg8, CL	—	3	3	3	3
		mem8, CL	8	EA + 4	EA + 6 + T	EA + 4	EA + 9 + 2T
			16				EA + 6 + T
		reg16, CL	—	3	3	3	3
		mem16, CL	8	EA + 4	EA + 6 + T	EA + 4	EA + 9 + 2T
			16				EA + 6 + T
		reg8, imm3	—	2	2	2	2
		mem8, imm3	8	EA + 4	EA + 6 + T	EA + 4	EA + 9 + 2T
16	EA + 6 + T						
reg16, imm4	—	2	2	2	2		
mem16, imm4	8	EA + 4	EA + 6 + T	EA + 4	EA + 9 + 2T		
	16				EA + 6 + T		

* 8 : 8-bit width 16 : 16-bit width — : Both 8-bit and 16-bit bus width

Table 17-9. Number of Clock Cycles (12/20)

Instruction Group	Mnemonic	Operands	Bus Width*	Byte Processing		Word Processing			
				On-Chip RAM Access	Other Access	On-Chip RAM Access	Other Access		
Bit manipulation instructions	NOT1	reg8, CL	—	3	3	3	3		
		mem8, CL	8	EA + 4	EA + 7 + T	EA + 4	EA + 10 + 2T		
			16				EA + 7 + T		
		reg16, CL	—	3	3	3	3		
		mem16, CL	8	EA + 4	EA + 7 + T	EA + 4	EA + 10 + 2T		
			16				EA + 7 + T		
		reg8, imm3	—	2	2	2	2		
		mem8, imm3	8	EA + 4	EA + 7 + T	EA + 4	EA + 10 + 2T		
			16				EA + 7 + T		
		reg16, imm4	—	2	2	2	2		
		mem16, imm4	8	EA + 4	EA + 7 + T	EA + 4	EA + 10 + 2T		
			16				EA + 7 + T		
		CY	—	2	2	2	2		
		Bit manipulation instructions	CLR1	reg8, CL	—	3	3	3	3
				mem8, CL	8	EA + 4	EA + 7 + T	EA + 4	EA + 10 + 2T
					16				EA + 7 + T
				reg16, CL	—	3	3	3	3
				mem16, CL	8	EA + 4	EA + 7 + T	EA + 4	EA + 10 + 2T
16	EA + 7 + T								
reg8, imm3	—			2	2	2	2		
mem8, imm3	8			EA + 4	EA + 7 + T	EA + 4	EA + 10 + 2T		
	16						EA + 7 + T		
reg16, imm4	—			2	2	2	2		
mem16, imm4	8			EA + 4	EA + 7 + T	EA + 4	EA + 10 + 2T		
	16						EA + 7 + T		
CY	—			2	2	2	2		
DIR	—			2	2	2	2		

* 8 : 8-bit width
 16 : 16-bit width
 — : Both 8-bit and 16-bit bus width

Table 17-9. Number of Clock Cycles (13/20)

Instruction Group	Mnemonic	Operands	Bus Width*	Byte Processing		Word Processing	
				On-Chip RAM Access	Other Access	On-Chip RAM Access	Other Access
Bit manipulation instructions	SET1	reg8, CL	—	3	3	3	3
		mem8, CL	8	EA + 4	EA + 7 + T	EA + 4	EA + 10 + 2T
			16				EA + 7 + T
		reg16, CL	—	3	3	3	3
		mem16, CL	8	EA + 4	EA + 7 + T	EA + 4	EA + 10 + 2T
			16				EA + 7 + T
		reg8, imm3	—	2	2	2	2
		mem8, imm3	8	EA + 4	EA + 7 + T	EA + 4	EA + 10 + 2T
			16				EA + 7 + T
		reg16, imm4	—	2	2	2	2
	mem16, imm4	8	EA + 4	EA + 7 + T	EA + 4	EA + 10 + 2T	
		16				EA + 7 + T	
	CY	—	2	2	2	2	
	DIR	—	2	2	2	2	
	BSCH	mem	8	EA + 8 + 3n + T	EA + 8 + 3n + T	EA + 11 + 3n + 2T	EA + 11 + 3n + 2T
			16	EA + 8 + 3n + T	EA + 8 + 3n + T	EA + 8 + 3n + T	EA + 8 + 3n + T
		reg	—	4 + 3n	4 + 3n	4 + 3n	4 + 3n
	Shift instructions	SHL	reg, 1	—	3	3	3
mem, 1			8	EA + 3	EA + 7 + T	EA + 3	EA + 10 + 2T
			16				EA + 7 + T
reg, CL			—	5 + n	5 + n	5 + n	5 + n
mem, CL			8	EA + 5 + n	EA + 8 + T + n	EA + 6 + n	EA + 11 + 2T + n
			16				EA + 8 + T + n
reg, imm8			—	5 + n	5 + n	5 + n	5 + n
mem, imm8			8	EA + 6 + n	EA + 8 + T + n	EA + 6 + n	EA + 11 + 2T + n
	16	EA + 8 + T + n					

* 8 : 8-bit width
 16 : 16-bit width
 — : Both 8-bit and 16-bit bus width

Remark Number of shifts (n in a bit manipulation instruction indicates the bit number searched for)

Table 17-9. Number of Clock Cycles (14/20)

Instruction Group	Mnemonic	Operands	Bus Width*	Byte Processing		Word Processing	
				On-Chip RAM Access	Other Access	On-Chip RAM Access	Other Access
Shift instructions	SHR	reg, 1	—	3	3	3	3
		mem, 1	8	EA + 3	EA + 7 + T	EA + 3	EA + 10 + 2T
			16				EA + 7 + T
		reg, CL	—	5 + n	5 + n	5 + n	5 + n
		mem, CL	8	EA + 5 + n	EA + 8 + T + n	EA + 6 + n	EA + 11 + 2T + n
			16				EA + 8 + T + n
		reg, imm8	—	5 + n	5 + n	5 + n	5 + n
	mem, imm8	8	EA + 6 + n	EA + 8 + T + n	EA + 6 + n	EA + 11 + 2T + n	
		16				EA + 8 + T + n	
	SHRA	reg, 1	—	3	3	3	3
		mem, 1	8	EA + 3	EA + 7 + T	EA + 3	EA + 10 + 2T
			16				EA + 7 + T
		reg, CL	—	5 + n	5 + n	5 + n	5 + n
		mem, CL	8	EA + 5 + n	EA + 8 + T + n	EA + 6 + n	EA + 11 + 2T + n
16			EA + 8 + T + n				
reg, imm8		—	5 + n	5 + n	5 + n	5 + n	
mem, imm8	8	EA + 6 + n	EA + 8 + T + n	EA + 6 + n	EA + 11 + 2T + n		
	16				EA + 8 + T + n		
Rotate instructions	ROL	reg, 1	—	3	3	3	3
		mem, 1	8	EA + 3	EA + 7 + T	EA + 3	EA + 10 + 2T
			16				EA + 7 + T
		reg, CL	—	5 + n	5 + n	5 + n	5 + n
		mem, CL	8	EA + 5 + n	EA + 8 + T + n	EA + 6 + n	EA + 11 + 2T + n
			16				EA + 8 + T + n
		reg, imm8	—	5 + n	5 + n	5 + n	5 + n
	mem, imm8	8	EA + 6 + n	EA + 8 + T + n	EA + 6 + n	EA + 11 + 2T + n	
		16				EA + 8 + T + n	

* 8 : 8-bit width
 16 : 16-bit width
 — : Both 8-bit and 16-bit bus width

Remark Number of shifts (n in a bit manipulation instruction indicates the bit number searched for)

Table 17-9. Number of Clock Cycles (15/20)

Instruction Group	Mnemonic	Operands	Bus Width*	Byte Processing		Word Processing	
				On-Chip RAM Access	Other Access	On-Chip RAM Access	Other Access
Rotate instructions	ROR	reg, 1	—	3	3	3	3
		mem, 1	8	EA + 3	EA + 7 + T	EA + 3	EA + 10 + 2T
			16				EA + 7 + T
		reg, CL	—	5 + n	5 + n	5 + n	5 + n
		mem, CL	8	EA + 5 + n	EA + 8 + T + n	EA + 6 + n	EA + 11 + 2T + n
			16				EA + 8 + T + n
		reg, imm8	—	5 + n	5 + n	5 + n	5 + n
	mem, imm8	8	EA + 6 + n	EA + 8 + T + n	EA + 6 + n	EA + 11 + 2T + n	
		16				EA + 8 + T + n	
	ROL	reg, 1	—	3	3	3	3
		mem, 1	8	EA + 3	EA + 7 + T	EA + 3	EA + 10 + 2T
			16				EA + 7 + T
		reg, CL	—	5 + n	5 + n	5 + n	5 + n
		mem, CL	8	EA + 5 + n	EA + 8 + T + n	EA + 6 + n	EA + 11 + 2T + n
			16				EA + 8 + T + n
		reg, imm8	—	5 + n	5 + n	5 + n	5 + n
	mem, imm8	8	EA + 6 + n	EA + 8 + T + n	EA + 6 + n	EA + 11 + 2T + n	
		16				EA + 8 + T + n	
	RORC	reg, 1	—	3	3	3	3
		mem, 1	8	EA + 3	EA + 7 + T	EA + 3	EA + 10 + 2T
			16				EA + 7 + T
reg, CL		—	5 + n	5 + n	5 + n	5 + n	
mem, CL		8	EA + 5 + n	EA + 8 + T + n	EA + 6 + n	EA + 11 + 2T + n	
		16				EA + 8 + T + n	
reg, imm8		—	5 + n	5 + n	5 + n	5 + n	
mem, imm8	8	EA + 6 + n	EA + 8 + T + n	EA + 6 + n	EA + 11 + 2T + n		
	16				EA + 8 + T + n		

* 8 : 8-bit width
 16 : 16-bit width
 — : Both 8-bit and 16-bit bus width

Remark Number of shifts

Table 17-9. Number of Clock Cycles (16/20)

Instruction Group	Mnemonic	Operands	Bus Width *1	Byte Processing		Word Processing		
				On-Chip RAM Access	Other Access	On-Chip RAM Access	Other Access	
Subroutine control instructions	CALL	near-proc	8	—	—	—	19 + 2T	
			16				16 + T	
		regptr16	8	—	—	—	18 + 2T	
			16				15 + T	
		memptr16	8	—	—	EA + 19 + 2T	EA + 24 + 4T	
			16			EA + 16 + T	EA + 18 + 2T	
		far-proc	8	—	—	—	29 + 4T	
			16				23 + 2T	
		memptr32	8	—	—	EA + 32 + 4T	EA + 44 + 8T	
			16			EA + 26 + 2T	EA + 32 + 4T	
		RET		8	—	—	—	18 + 2T
				16				15 + T
	pop-value		8	—	—	—	19 + 2T	
			16				16 + T	
*2	8		—	—	—	26 + 4T		
	16					20 + 2T		
pop-value*2	8		—	—	—	27 + 4T		
	16					21 + 2T		
Stack manipulation instructions	PUSH	mem16	8	—	—	EA + 7	EA + 13 + 2T	
			16			EA + 10 + T		
		reg16	—	—	—	7		
		sreg	—	—	—	7		
		xsreg/VPC	—	—	—	7		
		PSW	—	—	—	6		
		R	8	—	—	—	57 + 14T	
			16				36 + 7T	
	imm8	—	—	—	—	6		
imm16	—	—	—	—	6			

* 1. 8 : 8-bit width
 16 : 16-bit width
 — : Both 8-bit and 16-bit bus width

2. Segment-external

Remark n: Number of shifts

Table 17-9. Number of Clock Cycles (17/20)

Instruction Group	Mnemonic	Operands	Bus Width *1	Byte Processing		Word Processing		
				On-Chip RAM Access	Other Access	On-Chip RAM Access	Other Access	
Stack manipulation instructions	POP	mem16	8	—	—	EA + 13 + 2T	EA + 14 + 2T	
			16			EA + 10 + T	EA + 11 + T	
		reg16	8	—	—	—	10 + 2T	
			16				7 + T	
		sreg	8	—	—	—	10 + 2T	
			16				7 + T	
		xsreg/VPC	8	—	—	—	10 + 2T	
			16				7 + T	
		PSW	8	—	—	—	11 + 2T	
			16				8 + T	
		R	8	—	—	—	76 + 16T	
			16				52 + 8T	
		PREPARE*2	imm16, imm8	—	—	—	—	9
		DISPOSE		8	—	—	—	10 + 2T
16	7 + T							
Branch instructions	BR	near-label	—	—	—	—	9	
		short-label	—	—	—	—	9	
		regptr16	—	—	—	—	8	
		memptr16	8	—	—	EA + 9	EA + 14 + 2T	
			16				EA + 11 + T	
		far-label	—	—	—	—	9	
		memptr32	8	—	—	EA + 12	EA + 24 + 4T	
16	EA + 18 + 2T							

- * 1. 8 : 8-bit width
 16 : 16-bit width
 — : Both 8-bit and 16-bit bus width
2. When imm8 = 0. As shown below when imm8 ≥ 1.

PREPARE	imm16, imm8	8	—	—	—	15+2T+(16+4T)n
		16				14 + (12 + T)n

n : imm8

Table 17-9. Number of Clock Cycles (18/20)

Instruction Group	Mnemonic	Operands	Bus Width*	Byte Processing		Word Processing	
				On-Chip RAM Access	Other Access	On-Chip RAM Access	Other Access
Conditional branch instructions	BV	short-label	—	—	—	9/3	9/3
	BNV	short-label	—	—	—	9/3	9/3
	BC/BL	short-label	—	—	—	9/3	9/3
	BNC/BNL	short-label	—	—	—	9/3	9/3
	BE/BZ	short-label	—	—	—	9/3	9/3
	BNE/BNZ	short-label	—	—	—	9/3	9/3
	BNH	short-label	—	—	—	9/3	9/3
	BH	short-label	—	—	—	9/3	9/3
	BN	short-label	—	—	—	9/3	9/3
	BP	short-label	—	—	—	9/3	9/3
	BPE	short-label	—	—	—	9/3	9/3
	BPO	short-label	—	—	—	9/3	9/3
	BLT	short-label	—	—	—	9/3	9/3
	BGE	short-label	—	—	—	9/3	9/3
	BLE	short-label	—	—	—	9/3	9/3
	BGT	short-label	—	—	—	9/3	9/3
	DBNZNE	short-label	—	—	—	10/5	10/5
	DBNZE	short-label	—	—	—	10/5	10/5
	DBNZ	short-label	—	—	—	10/5	10/5
	BCWZ	short-label	—	—	—	10/5	10/5
BTCLR	sfr, imm3 short-label	8	—	21/14	—	—	
		16					
BTCLRL	sfrl, imm3 short-label	8	—	20/13	—	—	
		16					

* 8 : 8-bit width
 16: 16-bit width
 —: Both 8-bit and 16-bit bus width

Table 17-9. Number of Clock Cycles (19/20)

Instruction Group	Mnemonic	Operands	Bus Width *1	Byte Processing		Word Processing	
				On-Chip RAM Access	Other Access	On-Chip RAM Access	Other Access
Interrupt instructions	BRK*2	3	8	—	—	—	50 + 10T
			16	—	—	—	36 + 4T + t
		imm8 (≠3)	8	—	—	—	52 + 10T
			16	—	—	—	38 + 4T + t
	BRKV*2		8	—	—	—	51 + 10 T
			16	—	—	—	37 + 4T + t
	RETI		8	—	—	—	28 + 4T
			16	—	—	—	22 + 2T
	RETRBI		—	—	—	—	9
	FINT		—	3	3	3	3
CHKIND*3		8	—	—	EA + 11	EA + 21 + 4T	
		16	—	—	EA + 11	EA + 15 + 2T	
*4	BRKCS	reg16	—	—	—	12	12
	TSKSW	reg16	—	—	—	13	13
CPU control instructions	HALT		—	—	—	—	—
	STOP		—	—	—	—	—
	IDLE		—	—	—	—	—
	POLL		—	—	—	—	—
	DI		—	3	3	3	3
	EI		—	3	3	3	3
	BUSLOCK		—	0 to 1	0 to 1	0 to 1	0 to 1

- * 1. 8 : 8-bit width
16 : 16-bit width
— : Both 8-bit and 16-bit bus width
- 2. When BRK = 1, add 50 + 10T in case of 8-bit bus width, and 34 + 4T in case of 16-bit bus.
- 3. When (mem32) > reg16 or (mem32 + 2) < reg16, add 50 + 10T in case of 8-bit bus width, and 34 + 4T + t in case of 16-bit bus width.
- 4. Register bank switching instructions

Remarks When T ≥ 2, t = T - 1

Table 17-9. Number of Clock Cycles (20/20)

Instruction Group	Mnemonic	Operands	Bus Width *1	Byte Processing		Word Processing	
				On-Chip RAM Access	Other Access	On-Chip RAM Access	Other Access
CPU control instructions	FPO1	fp-op	8	—	—	—	50 + 10T
			16				36 + 4T + t
		fp-op, mem	8	—	—	—	EA + 50 + 10 T
			16				EA + 36 + 4T + t
	FPO2	fp-op	8	—	—	—	50 + 10T
			16				36 + 4T + t
		fp-op, mem	8	—	—	—	EA + 50 + 10 T
			16				EA + 36 + 4T + t
	NOP		—	4	4	4	4
	*2	RSTWDT	imm8, imm8'	8	—	9/54 + 10T*3	—
16				9/40 + 4T + t*3			
*4			—	0 to 1	0 to 1	0 to 1	0 to 1
Queue manipulation instructions	QHOUT	imm16	—	—	—	—	—
	QOUT	imm16	—	—	—	—	—
	QTIN	imm16	—	—	—	—	—
Dedicated fax instructions	ALBIT		—	—	—	—	—
	COLTRP		—	—	—	—	—
	MHENC		—	—	—	—	—
	MRENC		—	—	—	—	—
	SCHEOL		—	—	—	—	—
	GETBIT		—	—	—	—	—
	MHDEC		—	—	—	—	—
	MRDEC		—	—	—	—	—
CNVTRP		—	—	—	—	—	

- * 1. 8 : 8-bit width
16 : 16-bit width
— : Both 8-bit and 16-bit bus width
- 2. Watchdog timer manipulation instruction
- 3. Figure after / (slash) applies when word processing is performed during data error.
When T ≥ 2, t = T - 1
- 4. Segment override prefix instructions (DS0:, DS1:, PS:, SS:)
Extended segment override prefix instructions (DS2: DS3:)
Register file space access override prefix instruction (IRAM)

Instruction Group	Mnemonic	Operand(s)	Operation Code		Bytes	Operation	Flags													
			7 6 5 4 3 2 1 0	7 6 5 4 3 2 1 0			AC	CY	V	P	S	Z								
Data transfer instructions	MOV	reg, reg'	1 0 0 0 1 0 1 W	1 1 reg reg'	2	reg←reg'														
		mem, reg	1 0 0 0 1 0 0 W	mod reg mem	2 to 4	(mem)←reg														
		reg, mem	1 0 0 0 1 0 1 W	mod reg mem	2 to 4	reg←(mem)														
		mem, imm	1 1 0 0 0 1 1 W	mod0 0 0 mem	3 to 6	(mem)←imm														
		reg, imm	1 0 1 1 W reg		2 to 3	reg←imm														
		acc, dmem	1 0 1 0 0 0 0 W		3	If W = 0, AL←(dmem) If W = 1, AH←(dmem + 1), AL←(dmem)														
		dmem, acc	1 0 1 0 0 0 1 W		3	If W = 0, (dmem)←AL If W = 1, (dmem + 1)←AH, (dmem)←AL														
		sreg, reg16	1 0 0 0 1 1 1 0	1 1 0 sreg reg	2	sreg←reg16	sreg : SS, DS0, DS1													
		xsreg, reg16*	1 0 0 0 1 1 1 0	1 1 1 xsreg reg	2	xsreg←reg16	xsreg : DS2, DS3													
		sreg, mem16	1 0 0 0 1 1 1 0	mod 0 sreg mem	2 to 4	sreg←(mem16)	sreg : SS, DS0, DS1													
		xsreg, mem16*	1 0 0 0 1 1 1 0	mod 1 xsreg mem	2 to 4	xsreg←(mem16)														
		reg16, sreg	1 0 0 0 1 1 0 0	1 1 0 sreg reg	2	reg16←sreg														
		reg16, xsreg*	1 0 0 0 1 1 0 0	1 1 1 xsreg reg	2	reg16←xsreg														
		mem16, sreg	1 0 0 0 1 1 0 0	mod 0 sreg mem	2 to 4	(mem16)←sreg														
		mem16, xsreg*	1 0 0 0 1 1 0 0	mod 1 xsreg mem	2 to 4	(mem16)←xsreg														
		DS0, reg16, mem32	1 1 0 0 0 1 0 1	mod reg mem	2 to 4	reg16←(mem32) DS0←(mem32 + 2)														
		DS1, reg16, mem32	1 1 0 0 0 1 0 0	mod reg mem	2 to 4	reg16←(mem32) DS1←(mem32 + 2)														
		DS2, reg16*, mem32	0 0 0 0 1 1 1 1	0 0 1 1 1 1 1 0	3 to 5	reg16←(mem32) DS2←(mem32 + 2)														
mod reg mem																				
DS3, reg16*, mem32	0 0 0 0 1 1 1 1	0 0 1 1 0 1 1 0	3 to 5	reg16←(mem32) DS3←(mem32 + 2)																
	mod reg mem																			

* This instruction is newly added to the V25 or V35.

Phase-out/Discontinued

Instruction Group	Mnemonic	Operand(s)	Operation Code		Bytes	Operation	Flags							
			7 6 5 4 3 2 1 0	7 6 5 4 3 2 1 0			AC	CY	V	P	S	Z		
Data transfer instructions	MOV	AH, PSW	1 0 0 1 1 1 1 1		1	AH←S, Z, F1, AC, F0, P, $\overline{\text{IBRK}}$, CY								
		PSW, AH	1 0 0 1 1 1 1 0		1	S, Z, F1, AC, F0, P, $\overline{\text{IBRK}}$, CY←AH	×	×		×	×	×		
	LDEA	reg16, mem16	1 0 0 0 1 1 0 1	mod reg mem	2 to 4	reg16←mem16								
	TRANS TRANSB*1	src-table	1 1 0 1 0 1 1 1		1	AL←(BW + AL)								
	XCH	reg, reg'	1 0 0 0 0 1 1 W	1 1 reg reg'	2	reg↔reg'								
		mem, reg reg, mem	1 0 0 0 0 1 1 W	mod reg mem	2 to 4	(mem)↔reg								
		AW, reg16 reg16, AW	1 0 0 1 0 reg		1	AW↔reg16								
	MOVSPA*2		0 0 0 0 1 1 1 1	0 0 1 0 0 1 0 1	2	New register bank SS, SP ← Old register bank SS, SP								
MOVSPB*2	reg16	0 0 0 0 1 1 1 1	1 0 0 1 0 1 0 1	3	SS, SP of register bank indicated by reg16 ← current register bank SS, SP									
		1 1 1 1 1 reg												
Repeat prefixes	REPC		0 1 1 0 0 1 0 1		1	While CW ≠ 0, the following byte primitive block transfer instruction is executed and CW is decremented (-1). If there is a pending interrupt, it is serviced. If CY ≠ 1, the loop is exited.								
	REPNC		0 1 1 0 0 1 0 0		1	Same as above. If CY ≠ 0, the loop is exited.								
	REP		1 1 1 1 0 0 1 1		1	While CW ≠ 0, the following byte primitive block transfer instruction is executed and CW is decremented (-1). If there is a pending interrupt, it is serviced. If the primitive block transfer instruction is CMPBK or CPM, and Z ≠ 1, the loop is exited.								
	REPE													
	REPZ													
REPNE REPNZ		1 1 1 1 0 0 1 0		1	Same as above. If Z ≠ 0, the loop is exited.									

- * 1. The operand can be omitted in the case of the TRANS instruction. The TRANSB instruction has no operand.
2. This instruction is newly added to the V20 or V30.

Phase-out/Discontinued

Instruction Group	Mnemonic	Operand(s)	Operation Code		Bytes	Operation	Flags					
			7 6 5 4 3 2 1 0	7 6 5 4 3 2 1 0			AC	CY	V	P	S	Z
Primitive block transfer instructions	MOVBK MOVBKB MOVBKW	dst-block, src-block	1 0 1 0 0 1 0 W		1	If W = 0, (IY)←(IX) DIR = 0: IX←IX + 1, IY←IY + 1 DIR = 1: IX←IX - 1, IY←IY - 1 If W = 1, (IY + 1, IY)←(IX + 1, IX) DIR = 0: IX←IX + 2, IY←IY + 2 DIR = 1: IX←IX - 2, IY←IY - 2						
	CMPBK CMPBKB CMPBKW	src-block, dst-block	1 0 1 0 0 1 1 W		1	If W = 0, (IX) - (IY) DIR = 0: IX←IX + 1, IY←IY + 1 DIR = 1: IX←IX - 1, IY←IY - 1 If W = 1, (IX + 1, IX) - (IY + 1, IY) DIR = 0: IX←IX + 2, IY←IY + 2 DIR = 1: IX←IX - 2, IY←IY - 2	×	×	×	×	×	×
	CMPM CMPMB CMPMW	dst-block	1 0 1 0 1 1 1 W		1	If W = 0, AL - (IY) DIR = 0: IY←IY + 1 ; DIR = 1: IY←IY - 1 If W = 1, AW - (IY + 1, IY) DIR = 0: IY←IY + 2 ; DIR = 1: IY←IY - 2	×	×	×	×	×	×
	LDM LDMB LDMW	src-block	1 0 1 0 1 1 0 W		1	If W = 0, AL←(IX) DIR = 0: IX←IX + 1 ; DIR = 1: IX←IX - 1 If W = 1, AW + (IX + 1, IX) DIR = 0: IX + 2 ; DIR = 1: IX←IX - 2						
	STM STMB STMW	dst-block	1 0 1 0 1 0 1 W		1	If W = 0, (IY)←AL DIR = 0: IY←IY + 1 ; DIR = 1: IY←IY - 1 If W = 1, AW - (IY + 1, IY)←AW DIR = 0: IY←IY + 2 ; DIR = 1: IY←IY - 2						

Instruction Group	Mnemonic	Operand(s)	Operation Code		Bytes	Operation	Flags					
			7 6 5 4 3 2 1 0	7 6 5 4 3 2 1 0			AC	CY	V	P	S	Z
Bit field manipulation instructions	INS	reg8, reg8'	0 0 0 0 1 1 1 1	0 0 1 1 0 0 0 1	3	16-bit field←AW						
			1 1 reg' reg									
	reg8, imm4	0 0 0 0 1 1 1 1	0 0 1 1 1 0 0 1	4	16-bit field←AW							
		1 1 0 0 0 reg										
EXT	reg8, reg8'	reg8, reg8'	0 0 0 0 1 1 1 1	0 0 1 1 0 0 1 1	3	AW←16-bit field						
			1 1 reg' reg									
	reg8, imm4	reg8, imm4	0 0 0 0 1 1 1 1	0 0 1 1 1 0 1 1	4	AW←16-bit field						
			1 1 0 0 0 reg									
Input/output instructions	IN*	acc, imm8	1 1 1 0 0 1 0 W		2	If W = 0, AL←(imm8) If W = 1, AH←(imm8 + 1), AL←(imm8)						
		acc, DW	1 1 1 0 1 1 0 W		1	If W = 0, AL←(DW) If W = 1, AH←(DW + 1), AL←(DW)						
	OUT*	imm8, acc	1 1 1 0 0 1 1 W		2	If W = 0, (imm8)←AL If W = 1, (imm8 + 1)←AH, (imm8)←AL						
		DW, acc	1 1 1 0 1 1 1 W		1	If W = 0, (DW)←AL If W = 1, (DW + 1)←AH, (DW)←AL						
Primitive input/output instructions	INM*	dst-block, DW	0 1 1 0 1 1 0 W		1	If W = 0, (IY)←(DW) DIR = 0: IY←IY + 1 ; DIR = 1: IY←IY - 1 If W = 1, (IY + 1, IY)←(DW + 1, DW) DIR = 0: IY←IY + 2 ; DIR = 1: IY←IY - 2						
	OUTM*	DW, src-block	0 1 1 0 1 1 1 W			If W = 0, (DW)←(IX) DIR = 0: IX←IX + 1 ; DIR = 1: IX←IX - 1 If W = 1, (DW + 1, DW)←(IX + 1, IX) DIR = 0: IX←IX + 2 ; DIR = 1: IX←IX - 2						

* When $\overline{\text{IBRK}} = 0$, a software interrupt is generated automatically and the instruction is not executed.

Instruction Group	Mnemonic	Operand(s)	Operation Code		Bytes	Operation	Flags					
			7 6 5 4 3 2 1 0	7 6 5 4 3 2 1 0			AC	CY	V	P	S	Z
Addition/subtraction instructions	ADD	reg, reg'	0 0 0 0 0 0 1 W	1 1 reg reg'	2	reg←reg + reg'	×	×	×	×	×	×
		mem, reg	0 0 0 0 0 0 0 W	mod reg mem	2 to 4	(mem)←(mem) + reg	×	×	×	×	×	×
		reg, mem	0 0 0 0 0 0 1 W	mod reg mem	2 to 4	reg←reg + (mem)	×	×	×	×	×	×
		reg, imm	1 0 0 0 0 0 s W	1 1 0 0 0 reg	3 to 4	reg←reg + imm	×	×	×	×	×	×
		mem, imm	1 0 0 0 0 0 s W	mod 0 0 0 mem	3 to 6	(mem)←(mem) + imm	×	×	×	×	×	×
		acc, imm	0 0 0 0 0 1 0 W		2 to 3	If W = 0, AL←AL + imm If W = 1, AW←AW + imm	×	×	×	×	×	×
	ADDC	reg, reg'	0 0 0 1 0 0 1 W	1 1 reg reg'	2	reg←reg + reg' + CY	×	×	×	×	×	×
		mem, reg	0 0 0 1 0 0 0 W	mod reg mem	2 to 4	(mem)←(mem) + reg + CY	×	×	×	×	×	×
		reg, mem	0 0 0 1 0 0 1 W	mod reg mem	2 to 4	reg←reg + (mem) + CY	×	×	×	×	×	×
		reg, imm	1 0 0 0 0 0 s W	1 1 0 1 0 reg	3 to 4	reg←reg + imm + CY	×	×	×	×	×	×
		mem, imm	1 0 0 0 0 0 s W	mod 0 1 0 mem	3 to 6	(mem)←(mem) + imm + CY	×	×	×	×	×	×
		acc, imm	0 0 0 1 0 1 0 W		2 to 3	If W = 0, AL←AL + imm + CY If W = 1, AW←AW + imm + CY	×	×	×	×	×	×
	SUB	reg, reg'	0 0 1 0 1 0 1 W	1 1 reg reg'	2	reg←reg – reg'	×	×	×	×	×	×
		mem, reg	0 0 1 0 1 0 0 W	mod reg mem	2 to 4	(mem)←(mem) – reg	×	×	×	×	×	×
		reg, mem	0 0 1 0 1 0 1 W	mod reg mem	2 to 4	reg←reg – (mem)	×	×	×	×	×	×
		reg, imm	1 0 0 0 0 0 s W	1 1 1 0 1 reg	3 to 4	reg←reg – imm	×	×	×	×	×	×
		mem, imm	1 0 0 0 0 0 s W	mod 1 0 1 mem	3 to 6	(mem)←(mem) – imm	×	×	×	×	×	×
		acc, imm	0 0 1 0 1 1 0 W		2 to 3	If W = 0, AL←AL – imm If W = 1, AW←AW – imm	×	×	×	×	×	×
	SUBC	reg, reg'	0 0 0 1 1 0 1 W	1 1 reg reg'	2	reg←reg – reg' – CY	×	×	×	×	×	×
		mem, reg	0 0 0 1 1 0 0 W	mod reg mem	2 to 4	(mem)←(mem) – reg – CY	×	×	×	×	×	×
		reg, mem	0 0 0 1 1 0 1 W	mod reg mem	2 to 4	reg←reg – (mem) – CY	×	×	×	×	×	×
reg, imm		1 0 0 0 0 0 s W	1 1 0 1 1 reg	3 to 4	reg←reg – imm – CY	×	×	×	×	×	×	
mem, imm		1 0 0 0 0 0 s W	mod 0 1 1 mem	3 to 6	(mem)←(mem) – imm – CY	×	×	×	×	×	×	
acc, imm		0 0 0 1 1 1 0 W		2 to 3	If W = 0, AL←AL – imm – CY If W = 1, AW←AW – imm – CY	×	×	×	×	×	×	

Phase-out/Discontinued

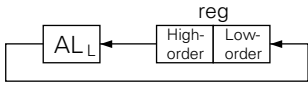
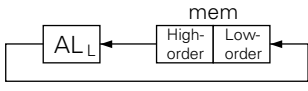
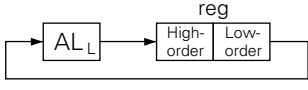
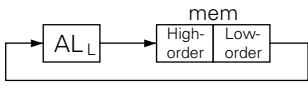
Instruction Group	Mnemonic	Operand(s)	Operation Code		Bytes	Operation	Flags					
			7 6 5 4 3 2 1 0	7 6 5 4 3 2 1 0			AC	CY	V	P	S	Z
BCD operation instructions	ADD4S*1	(dst-string, src-string)	0 0 0 0 1 1 1 1	0 0 1 0 0 0 0 0	2	dst BCD string ← dst BCD string + src BCD string*2	U	×	U	U	U	×
	SUB4S*1	(dst-string, src-string)	0 0 0 0 1 1 1 1	0 0 1 0 0 0 1 0	2	dst BCD string ← dst BCD string – src BCD string*2	U	×	U	U	U	×
	CMP4S*1	(dst-string, src-string)	0 0 0 0 1 1 1 1	0 0 1 0 0 1 1 0	2	dst BCD string – src BCD string*2	U	×	U	U	U	×
	ROL4	reg8	0 0 0 0 1 1 1 1 1 1 0 0 0 reg	0 0 1 0 1 0 0 0	3							
		mem8	0 0 0 0 1 1 1 1 mod 0 0 0 mem	0 0 1 0 1 0 0 0	3 to 5							
	ROR4	reg8	0 0 0 0 1 1 1 1 1 1 0 0 0 reg	0 0 1 0 1 0 1 0	3							
mem8		0 0 0 0 1 1 1 1 mod 0 0 0 mem	0 0 1 0 1 0 1 0	3 to 5								
Increment/decrement instructions	INC	reg8	1 1 1 1 1 1 1 0	1 1 0 0 0 reg	2	reg8 ← reg8 + 1	×		×	×	×	×
		mem	1 1 1 1 1 1 1 W	mod 0 0 0 mem	2 to 4	(mem) ← (mem) + 1	×		×	×	×	×
		reg16	0 1 0 0 0 reg		1	reg16 ← reg16 + 1	×		×	×	×	×
	DEC	reg8	1 1 1 1 1 1 1 0	1 1 0 0 1 reg	2	reg8 ← reg8 – 1	×		×	×	×	×
		mem	1 1 1 1 1 1 1 W	mod 0 0 1 mem	2 to 4	(mem) ← (mem) – 1	×		×	×	×	×
		reg16	0 1 0 0 1 reg		1	reg16 ← reg16 – 1	×		×	×	×	×

- * 1. The operand can be omitted.
 2. The number of BCD digits is given by the CL register: a value between 1 and 254 can be set.

Instruction Group	Mnemonic	Operand(s)	Operation Code		Bytes	Operation	Flags					
			7 6 5 4 3 2 1 0	7 6 5 4 3 2 1 0			AC	CY	V	P	S	Z
Multiplication instructions	MULU	reg8	1 1 1 1 0 1 1 0	1 1 1 0 0 reg	2	AW←AL × reg8 AH = 0: CY←0, V←0 AH ≠ 0: CY←1, V←1	U	×	×	U	U	U
		mem8	1 1 1 1 0 1 1 0	mod 1 0 0 mem	2 to 4	AW←AL × (mem8) AH = 0: CY←0, V←0 AH ≠ 0: CY←1, V←1	U	×	×	U	U	U
		reg16	1 1 1 1 0 1 1 1	1 1 1 0 0 reg	2	DW, AW←AW × reg16 DW = 0: CY←0, V←0 DW ≠ 0: CY←1, V←1	U	×	×	U	U	U
		mem16	1 1 1 1 0 1 1 1	mod 1 0 0 mem	2 to 4	DW, AW←AW × (mem16) DW = 0: CY←0, V←0 DW ≠ 0: CY←1, V←1	U	×	×	U	U	U
	MUL	reg8	1 1 1 1 0 1 1 0	1 1 1 0 1 reg	2	AW←AL × reg8 AH = AL sign extension: CY←0, V←0 AH ≠ AL sign extension: CY←1, V←1	U	×	×	U	U	U
		mem8	1 1 1 1 0 1 1 0	mod 1 0 1 mem	2 to 4	AW←AL × (mem8) AH = AL sign extension: CY←0, V←0 AH ≠ AL sign extension: CY←1, V←1	U	×	×	U	U	U
		reg16	1 1 1 1 0 1 1 1	1 1 1 0 1 reg	2	DW, AW←AW × reg16 DW = AW sign extension: CY←0, V←0 DW ≠ AW sign extension: CY←1, V←1	U	×	×	U	U	U
		mem16	1 1 1 1 0 1 1 1	mod 1 0 1 mem	2 to 4	DW, AW←AW × (mem16) DW = AW sign extension: CY←0, V←0 DW ≠ AW sign extension: CY←1, V←1	U	×	×	U	U	U
		reg16, (reg16')* imm8	0 1 1 0 1 0 1 1	1 1 reg reg'	3	reg16←reg16' × imm8 Product ≤ 16 bits: CY←0, V←0 Product > 16 bits: CY←1, V←1	U	×	×	U	U	U
		reg16, mem16, imm8	0 1 1 0 1 0 1 1	mod reg mem	3 to 5	reg16←(mem16) × imm8 Product ≤ 16 bits: CY←0, V←0 Product > 16 bits: CY←1, V←1	U	×	×	U	U	U
		reg16, (reg16')* imm16	0 1 1 0 1 0 0 1	1 1 reg reg'	4	reg16←reg16' × imm16 Product ≤ 16 bits: CY←0, V←0 Product > 16 bits: CY←1, V←1	U	×	×	U	U	U
		reg16, mem16, imm16	0 1 1 0 1 0 0 1	mod reg mem	4 to 6	reg16←(mem16) × imm16 Product ≤ 16 bits: CY←0, V←0 Product > 16 bits: CY←1, V←1	U	×	×	U	U	U

* The 2nd operand can be omitted, in which case the same register as the 1st operand is taken as being specified.

Phase-out/Discontinued

Instruction Group	Mnemonic	Operand(s)	Operation Code		Bytes	Operation	Flags					
			7 6 5 4 3 2 1 0	7 6 5 4 3 2 1 0			AC	CY	V	P	S	Z
			Unsigned division instructions	DIVU			reg8	1 1 1 1 0 1 1 0	1 1 1 1 0 reg	2	temp←AW If temp ÷ reg8 ≤ FFH AH←temp%reg8, AL←temp ÷ reg8 If temp ÷ reg8 > FFH (SP - 1, SP - 2)←PSW, (SP - 3, SP - 4)←PS (SP - 5, SP - 6)←PC, SP←SP - 6 IE←0, BRK←0, PS←(3, 2), PC←(1, 0)	U
mem8	1 1 1 1 0 1 1 0	mod 1 1 0 mem	2 to 4		temp←AW If temp ÷ (mem8) ≤ FFH AH←temp%(mem8), AL←temp ÷ (mem8) If temp ÷ (mem8) > FFH (SP - 1, SP - 2)←PSW, (SP - 3, SP - 4)←PS (SP - 5, SP - 6)←PC, SP←SP - 6 IE←0, BRK←0, PS←(3, 2), PC←(1, 0)	U	U	U	U	U	U	
reg16	1 1 1 1 0 1 1 1	1 1 1 1 0 reg	2		temp←DW, AW If temp ÷ reg16 ≤ FFFFH DW←temp%reg16, AW←temp ÷ reg16 If temp ÷ reg16 > FFFFH (SP - 1, SP - 2)←PSW, (SP - 3, SP - 4)←PS (SP - 5, SP - 6)←PC, SP←SP - 6 IE←0, BRK←0, PS←(3, 2), PC←(1, 0)	U	U	U	U	U	U	
mem16	1 1 1 1 0 1 1 1	mod 1 1 0 mem	2 to 4		temp←DW, AW If temp ÷ (mem16) ≤ FFFFH DW←temp%(mem16), AW←temp ÷ (mem16) If temp ÷ (mem16) > FFFFH (SP - 1, SP - 2)←PSW, (SP - 3, SP - 4)←PS (SP - 5, SP - 6)←PC, SP←SP - 6 IE←0, BRK←0, PS←(3, 2), PC←(1, 0)	U	U	U	U	U	U	

Instruction Group	Mnemonic	Operand(s)	Operation Code		Bytes	Operation	Flags					
			7 6 5 4 3 2 1 0	7 6 5 4 3 2 1 0			AC	CY	V	P	S	Z
Signed division instructions	DIV	reg8	1 1 1 1 0 1 1 0	1 1 1 1 1 reg	2	temp←AW If temp ÷ reg8 > 0 and temp ÷ reg8 ≤ 7FH; or if temp ÷ reg8 < 0 and temp ÷ reg8 > 0 - 7FH - 1 AH←temp%reg8, AL←temp ÷ reg8 If temp ÷ reg8 > 0 and temp ÷ reg8 > 7FH; or if temp ÷ reg8 < 0 and temp ÷ reg8 ≤ 0 - 7FH - 1 (SP - 1, SP - 2)←PSW, (SP - 3, SP - 4)←PS (SP - 5, SP - 6)←PC, SP←SP - 6 IE←0, BRK←0, PS←(3, 2), PC←(1, 0)	U	U	U	U	U	U
		mem8	1 1 1 1 0 1 1 0	mod 1 1 1 mem	2 to 4	temp←AW If temp ÷ (mem8) > 0 and temp ÷ (mem8) ≤ 7FH; or if temp ÷ (mem8) < 0 and temp ÷ (mem8) > 0 - 7FH - 1 AH←temp%(mem8), AL←temp ÷ (mem8) If temp ÷ (mem8) > 0 and temp ÷ (mem8) > 7FH; or if temp ÷ (mem8) < 0 and temp ÷ (mem8) ≤ 0 - 7FH - 1 (SP - 1, SP - 2)←PSW, (SP - 3, SP - 4)←PS (SP - 5, SP - 6)←PC, SP←SP - 6 IE←0, BRK←0, PS←(3, 2), PC←(1, 0)	U	U	U	U	U	U
		reg16	1 1 1 1 0 1 1 1	1 1 1 1 1 reg	2	temp←DW, AW If temp ÷ reg16 > 0 and temp ÷ reg16 ≤ 7FFFH; or if temp ÷ reg16 < 0 and temp ÷ reg16 > 0 - 7FFFH - 1 DW←temp%reg16, AW←temp ÷ reg16 If temp ÷ reg16 > 0 and temp ÷ reg16 > 7FFFH; or if temp ÷ reg16 < 0 and temp ÷ reg16 ≤ 0 - 7FFFH - 1 (SP - 1, SP - 2)←PSW, (SP - 3, SP - 4)←PS (SP - 5, SP - 6)←PC, SP←SP - 6 IE←0, BRK←0, PS←(3, 2), PC←(1, 0)	U	U	U	U	U	U
		mem16	1 1 1 1 0 1 1 1	mod 1 1 1 mem	2 to 4	temp←DW, AW If temp ÷ (mem16) > 0 and temp ÷ (mem16) ≤ 7FFFH; or if temp ÷ (mem16) < 0 and temp ÷ (mem16) > 0 - 7FFFH - 1 AH←temp%(mem16), AW←temp ÷ (mem16) If temp ÷ (mem16) > 0 and temp ÷ (mem16) > 7FFFH; or if temp ÷ (mem16) < 0 and temp ÷ (mem16) ≤ 0 - 7FFFH - 1 (SP - 1, SP - 2)←PSW, (SP - 3, SP - 4)←PS (SP - 5, SP - 6)←PC, SP←SP - 6 IE←0, BRK←0, PS←(3, 2), PC←(1, 0)	U	U	U	U	U	U

Phase-out/Discontinued

Instruction Group	Mnemonic	Operand(s)	Operation Code		Bytes	Operation	Flags					
			7 6 5 4 3 2 1 0	7 6 5 4 3 2 1 0			AC	CY	V	P	S	Z
BCD adjustment instructions	ADJBA		0 0 1 1 0 1 1 1		1	If AL \wedge 0FH > 9 or AC = 1: AL \leftarrow AL + 6 AH \leftarrow AH + 1, AC \leftarrow 1, CY \leftarrow AC, AL \leftarrow AL \wedge 0FH	×	×	U	U	U	U
	ADJ4A		0 0 1 0 0 1 1 1		1	If AL \wedge 0FH > 9 or AC = 1: AL \leftarrow AL + 6, AC \leftarrow 1 If AL > 9FH or CY = 1: AL \leftarrow AL + 60H, CY \leftarrow 1	×	×	U	×	×	×
	ADJBS		0 0 1 1 1 1 1 1		1	If AL \wedge 0FH > 9 or AC = 1: AL \leftarrow AL - 6, AC \leftarrow 1 CY \leftarrow AC, AL \leftarrow AL \wedge 0FH	×	×	U	U	U	U
	ADJ4S		0 0 1 0 1 1 1 1		1	If AL \wedge 0FH > 9 or AC = 1: AL \leftarrow AL - 6, CY \leftarrow CY \vee AC, AC \leftarrow 1 If AL > 9FH or CY = 1: AL \leftarrow AL - 60H, CY \leftarrow 1	×	×	U	×	×	×
Data conversion instructions	CVTBD		1 1 0 1 0 1 0 0	0 0 0 0 1 0 1 0	2	AH \leftarrow AH \div 0AH, AL \leftarrow AL%0AH	U	U	U	×	×	×
	CVTDB		1 1 0 1 0 1 0 1	0 0 0 0 1 0 1 0	2	AL \leftarrow AH \times 0AH + AL, AH \leftarrow 0	U	U	U	×	×	×
	CVTBW		1 0 0 1 1 0 0 0		1	If AL < 80H: AH \leftarrow 0, otherwise: AH \leftarrow FFH						
	CVTWL		1 0 0 1 1 0 0 1		1	If AW < 8000H: DW \leftarrow 0, otherwise: DW \leftarrow FFFFH						
Comparison instruction	CMP	reg, reg'	0 0 1 1 1 0 1 W	1 1 reg reg'	2	reg - reg'	×	×	×	×	×	×
		mem, reg	0 0 1 1 1 0 0 W	mod reg mem	2 to 4	(mem) - reg	×	×	×	×	×	×
		reg, mem	0 0 1 1 1 0 1 W	mod reg mem	2 to 4	reg - (mem)	×	×	×	×	×	×
		reg, imm	1 0 0 0 0 0 s W	1 1 1 1 1 reg	3 to 4	reg - imm	×	×	×	×	×	×
		mem, imm	1 0 0 0 0 0 s W	mod 1 1 1 mem	3 to 6	(mem) - imm	×	×	×	×	×	×
		acc, imm	0 0 1 1 1 1 0 W		2 to 3	If W = 0, AL - imm If W = 1, AW - imm	×	×	×	×	×	×
*	NOT	reg	1 1 1 1 0 1 1 W	1 1 0 1 0 reg	2	reg \leftarrow $\overline{\text{reg}}$						
		mem	1 1 1 1 0 1 1 W	mod 0 1 0 mem	2 to 4	(mem) - ($\overline{\text{mem}}$)						
	NEG	reg	1 1 1 1 0 1 1 W	1 1 0 1 1 reg	2	reg \leftarrow $\overline{\text{reg}}$ + 1	×	×	×	×	×	×
		mem	1 1 1 1 0 1 1 W	mod 0 1 1 mem	2 to 4	(mem) \leftarrow $\overline{(\text{mem})}$ + 1	×	×	×	×	×	×

* Complement operation instructions

Instruction Group	Mnemonic	Operand(s)	Operation Code		Bytes	Operation	Flags					
			7 6 5 4 3 2 1 0	7 6 5 4 3 2 1 0			AC	CY	V	P	S	Z
Logical operation instructions	TEST	reg, reg'	1 0 0 0 0 1 0 W	1 1 reg' reg	2	reg \wedge reg'	U	0	0	×	×	×
		mem, reg reg, mem	1 0 0 0 0 1 0 W	mod reg mem	2 to 4	(mem) \wedge reg	U	0	0	×	×	×
		reg, imm	1 1 1 1 0 1 1 W	1 1 0 0 0 reg	3 to 4	reg \wedge imm	U	0	0	×	×	×
		mem, imm	1 1 1 1 0 1 1 W	mod 0 0 0 mem	3 to 6	(mem) \wedge imm	U	0	0	×	×	×
		acc, imm	1 0 1 0 1 0 0 W		2 to 3	If W = 0, AL \wedge imm8 If W = 1, AW \wedge imm16	U	0	0	×	×	×
	AND	reg, reg'	0 0 1 0 0 0 1 W	1 1 reg reg'	2	reg \leftarrow reg \wedge reg'	U	0	0	×	×	×
		mem, reg	0 0 1 0 0 0 0 W	mod reg mem	2 to 4	(mem) \leftarrow (mem) \wedge reg	U	0	0	×	×	×
		reg, mem	0 0 1 0 0 0 1 W	mod reg mem	2 to 4	reg \leftarrow reg \wedge (mem)	U	0	0	×	×	×
		reg, imm	1 0 0 0 0 0 0 W	1 1 1 0 0 reg	3 to 4	reg \leftarrow reg \wedge imm	U	0	0	×	×	×
		mem, imm	1 0 0 0 0 0 0 W	mod 1 0 0 mem	3 to 6	(mem) \leftarrow (mem) \wedge imm	U	0	0	×	×	×
		acc, imm	0 1 0 0 1 0 W		2 to 3	If W = 0, AL \leftarrow AL \wedge imm8 If W = 1, AW \leftarrow AW \wedge imm16	U	0	0	×	×	×
	OR	reg, reg'	0 0 0 0 1 0 1 W	1 1 reg reg'	2	reg \leftarrow reg \vee reg'	U	0	0	×	×	×
		mem, reg	0 0 0 0 1 0 0 W	mod reg mem	2 to 4	(mem) \leftarrow (mem) \vee reg	U	0	0	×	×	×
		reg, mem	0 0 0 0 1 0 1 W	mod reg mem	2 to 4	reg \leftarrow reg \vee (mem)	U	0	0	×	×	×
		reg, imm	1 0 0 0 0 0 0 W	1 1 0 0 1 reg	3 to 4	reg \leftarrow reg \vee imm	U	0	0	×	×	×
		mem, imm	1 0 0 0 0 0 0 W	mod 0 0 1 mem	3 to 6	(mem) \leftarrow (mem) \vee imm	U	0	0	×	×	×
		acc, imm	0 0 0 0 1 1 0 W		2 to 3	If W = 0, AL \leftarrow AL \vee imm8 If W = 1, AW \leftarrow AW \vee imm16	U	0	0	×	×	×
	XOR	reg, reg'	0 0 1 1 0 0 1 W	1 1 reg reg'	2	reg \leftarrow reg ∇ reg'	U	0	0	×	×	×
		mem, reg	0 0 1 1 0 0 0 W	mod reg mem	2 to 4	(mem) \leftarrow (mem) ∇ reg'	U	0	0	×	×	×
		reg, mem	0 0 1 1 0 0 1 W	mod reg mem	2 to 4	reg \leftarrow reg ∇ (mem)	U	0	0	×	×	×
		reg, imm	1 0 0 0 0 0 0 W	1 1 1 1 0 reg	3 to 4	reg \leftarrow reg ∇ imm	U	0	0	×	×	×
mem, imm		1 0 0 0 0 0 0 W	mod 1 1 0 mem	3 to 6	(mem) \leftarrow (mem) ∇ imm	U	0	0	×	×	×	
acc, imm		0 0 1 1 0 1 0 W		2 to 3	If W = 0, AL \leftarrow AL ∇ imm8 If W = 1, AW \leftarrow AW ∇ imm16	U	0	0	×	×	×	

Phase-out/Discontinued

Instruction Group	Mnemonic	Operand(s)	Operation Code		Bytes	Operation	Flags					
			7 6 5 4 3 2 1 0	7 6 5 4 3 2 1 0			AC	CY	V	P	S	Z
			Bit manipulation instructions									
TEST1	reg8, CL		0 0 0 1 0 0 0 0	1 1 0 0 0 reg	3	reg8 bit NO.CL = 0 : Z←1 reg8 bit NO.CL = 1 : Z←0	U	0	0	U	U	×
	mem8, CL		0 0 0 0	mod 0 0 0 mem	3 to 5	(mem8) bit NO.CL = 0 : Z←1 (mem8) bit NO.CL = 1 : Z←0	U	0	0	U	U	×
	reg16, CL		0 0 0 1	1 1 0 0 0 reg	3	reg16 bit NO.CL = 0 : Z←1 reg16 bit NO.CL = 1 : Z←0	U	0	0	U	U	×
	mem16, CL		0 0 0 1	mod 0 0 0 mem	3 to 5	(mem16) bit NO.CL = 0 : Z←1 (mem16) bit NO.CL = 1 : Z←0	U	0	0	U	U	×
	reg8, imm3		1 0 0 0	1 1 0 0 0 reg	4	reg8 bit NO.imm3 = 0 : Z←1 reg8 bit NO.imm3 = 1 : Z←0	U	0	0	U	U	×
	mem8, imm3		1 0 0 0	mod 0 0 0 mem	4 to 6	(mem8) bit NO.imm3 = 0 : Z←1 (mem8) bit NO.imm3 = 1 : Z←0	U	0	0	U	U	×
	reg16, imm4		1 0 0 1	1 1 0 0 0 reg	4	reg16 bit NO.imm4 = 0 : Z←1 reg16 bit NO.imm4 = 1 : Z←0	U	0	0	U	U	×
	mem16, imm4		1 0 0 0	mod 0 0 0 mem	4 to 6	(mem16) bit NO.imm4 = 0 : Z←1 (mem16) bit NO.imm4 = 1 : Z←0	U	0	0	U	U	×
	reg8, CL		0 1 1 0	1 1 0 0 0 reg	3	reg8 bit NO.CL←reg8 bit NO.CL						
	mem8, CL		0 1 1 0	mod 0 0 0 mem	3 to 5	(mem8) bit NO.CL←(mem8) bit NO.CL						
	reg16, CL		0 1 1 1	1 1 0 0 0 reg	3	reg16 bit NO.CL←reg16 bit NO.CL						
	mem16, CL		0 1 1 1	mod 0 0 0 mem	3 to 5	(mem16) bit NO.CL←(mem16) bit NO.CL						
	reg8, imm3		1 1 1 0	1 1 0 0 0 reg	4	reg8 bit NO.imm3←reg8 bit NO.imm3						
	mem8, imm3		1 1 1 0	mod 0 0 0 mem	4 to 6	(mem8) bit NO.imm3←(mem8) bit NO.imm3						
reg16, imm4		1 1 1 1	1 1 0 0 0 reg	4	reg16 bit NO.imm4←reg16 bit NO.imm4							
mem16, imm4		1 1 1 1	mod 0 0 0 mem	4 to 6	(mem16) bit NO.imm4←(mem16) bit NO.imm4							

2nd byte *

3rd byte *

* 1st byte = 0FH

NOT1	CY	1 1 1 1 0 1 0 1		1	CY←CY		×				
------	----	-----------------	--	---	-------	--	---	--	--	--	--

Phase-out/Discontinued

Instruction Group	Mnemonic	Operand(s)	Operation Code		Bytes	Operation	Flags						
			7 6 5 4 3 2 1 0	7 6 5 4 3 2 1 0			AC	CY	V	P	S	Z	
			Bit manipulation instructions	CLR1			reg8, CL	0 0 0 1 0 0 1 0	1 1 0 0 0 reg	3	reg8 bit NO.CL←0		
mem8, CL		0 0 1 0	mod 0 0 0 mem		3 to 5	(mem8) bit NO.CL←0							
reg16, CL		0 0 1 1	1 1 0 0 0 reg		3	reg16 bit NO.CL←0							
mem16, CL		0 0 1 1	mod 0 0 0 mem		3 to 5	(mem16) bit NO.CL←0							
reg8, imm3		1 0 1 0	1 1 0 0 0 reg		4	reg8 bit NO.imm3←0							
mem8, imm3		1 0 1 0	mod 0 0 0 mem		4 to 6	(mem8) bit NO.imm3←0							
reg16, imm4		1 0 1 1	1 1 0 0 0 reg		4	reg16 bi NO.imm4←0							
mem16, imm4		1 0 1 1	mod 0 0 0 mem		4 to 6	(mem16) bit NO.imm4←0							
SET1	reg8, CL		0 1 0 0		1 1 0 0 0 reg	3	reg8 bit NO.CL←1						
	mem8, CL		0 1 0 0		mod 0 0 0 mem	3 to 5	(mem8) bit NO.CL←1						
	reg16, CL		0 1 0 1		1 1 0 0 0 reg	3	reg16 bit NO.CL←1						
	mem16, CL		0 1 0 1		mod 0 0 0 mem	3 to 5	(mem16) bit NO.CL←1						
	reg8, imm3		1 1 0 0		1 1 0 0 0 reg	4	reg8 bit NO.imm3←1						
	mem8, imm3		1 1 0 0		mod 0 0 0 mem	4 to 6	(mem8) bit NO.imm3←1						
	reg16, imm4		1 1 0 1	1 1 0 0 0 reg	4	reg16 bi NO.imm4←1							
	mem16, imm4		1 1 0 1	mod 0 0 0 mem	4 to 6	(mem16) bit NO.imm4←1							

2nd byte *

3rd byte *

* 1st byte = 0FH

CLR1	CY	1 1 1 1 1 0 0 0		1	CY←0		0				
	DIR	1 1 1 1 1 1 0 0		1	DIR←0						
SET1	CY	1 1 1 1 1 0 0 1		1	CY←1		1				
	DIR	1 1 1 1 1 1 0 1		1	DIR←0						

Phase-out/Discontinued

Instruction Group	Mnemonic	Operand(s)	Operation Code		Bytes	Operation	Flags					
			7 6 5 4 3 2 1 0	7 6 5 4 3 2 1 0			AC	CY	V	P	S	Z
Bit manipulation instruction	BSCH*	reg8	0 0 0 0 1 1 1 1	0 0 1 1 1 1 0 0	3	<1> CL← 0 <2> [When reg8 bit No.CL=0] if CL<7, re-executed from CL← CL+1, <2> if CL=7 Z← 1 [When reg8 bit No.CL=1] Z← 0	U	U	U	U	U	×
			1 1 0 0 0 reg									
		mem8	0 0 0 0 1 1 1 1	0 0 1 1 1 1 0 0	3 to 5	<1> CL← 0 <2> [When mem8 bit No.CL=0] if CL<7, re-executed from CL← CL+1, <2> if CL=7 Z← 1 [When mem8 bit No.CL=1] Z← 0	U	U	U	U	U	×
			mod 0 0 0 mem									
		reg16	0 0 0 0 1 1 1 1	0 0 1 1 1 1 0 1	3	<1> CL← 0 <2> [When reg16 bit No.CL=0] if CL<15, re-executed from CL← CL+1, <2> if CL=15 Z← 1 [When reg16 bit No.CL=1] Z← 0	U	U	U	U	U	×
			1 1 0 0 0 reg									
		mem16	0 0 0 0 1 1 1 1	0 0 1 1 1 1 0 1	3 to 5	<1> CL← 0 <2> [When mem16 bit No.CL=0] if CL<15, re-executed from CL← CL+1, <2> if CL=15 Z← 1 [When mem16 bit No.CL=1] Z← 0	U	U	U	U	U	×
			mod 0 0 0 mem									
Queue manipulation instructions	QHOUT*	imm16	0 0 0 0 1 1 1 1	0 1 1 1 0 0 0 0	4	Removes block queued at head of queue and stores its segment address in P2.	U	U	U	U	U	×
	QOUT*	imm16	0 0 0 0 1 1 1 1	0 1 1 1 0 0 0 1	4	Removes queue block indicated by P2.	U	U	U	U	U	×
	QTIN*	imm16	0 0 0 0 1 1 1 1	0 1 1 1 0 0 1 0	4	Queues block indicated by P2 at end of queue.						

* This instruction is newly added to the V25 or V35.

Remarks P2: Parameter table (in register file)

Instruction Group	Mnemonic	Operand(s)	Operation Code		Bytes	Operation	Flags					
			7 6 5 4 3 2 1 0	7 6 5 4 3 2 1 0			AC	CY	V	P	S	Z
Shift instructions	SHL	reg, 1	1 1 0 1 0 0 0 W	1 1 1 0 0 reg	2	CY←reg MSB, reg←reg × 2 If reg MSB ≠ CY, V←1 If reg MSB = CY, V←0	U	×	×	×	×	×
		mem, 1	1 1 0 1 0 0 0 W	mod 1 0 0 mem	2 to 4	CY←(mem) MSB, (mem)←(mem) × 2 If (mem) MSB ≠ CY, V←1 If (mem) MSB = CY, V←0	U	×	×	×	×	×
		reg, CL	1 1 0 1 0 0 1 W	1 1 1 0 0 reg	2	temp←CL, while temp ≠ 0, the following operations are repeated: CY←reg MSB, reg←reg × 2 temp←temp - 1	U	×	U	×	×	×
		mem, CL	1 1 0 1 0 0 1 W	mod 1 0 0 mem	2 to 4	temp←CL, while temp ≠ 0, the following operations are repeated: CY←(mem) MSB, (mem)←(mem) × 2 temp←temp - 1	U	×	U	×	×	×
		reg, imm8	1 1 0 0 0 0 0 W	1 1 1 0 0 reg	3	temp←imm8, while temp ≠ 0, the following operations are repeated: CY←reg MSB, reg←reg × 2 temp←temp - 1	U	×	U	×	×	×
		mem, imm8	1 1 0 0 0 0 0 W	mod 1 0 0 mem	3 to 5	temp←imm8, while temp ≠ 0, the following operations are repeated: CY←(mem) MSB, (mem)←(mem) × 2 temp←temp - 1	U	×	U	×	×	×
	SHR	reg, 1	1 1 0 1 0 0 0 W	1 1 1 0 1 reg	2	CY←reg LSB, reg←reg ÷ 2 If reg MSB ≠ bit after reg MSB: V←1 If reg MSB = bit after reg MSB: V←0	U	×	×	×	×	×
		mem, 1	1 1 0 1 0 0 0 W	mod 1 0 1 mem	2 to 4	CY←(mem) LSB, (mem)←(mem) ÷ 2 If (mem) MSB ≠ bit after (mem) MSB: V←1 If (mem) MSB = bit after (mem) MSB: V←0	U	×	×	×	×	×
		reg, CL	1 1 0 1 0 0 1 W	1 1 1 0 1 reg	2	temp←CL, while temp ≠ 0, the following operations are repeated: CY←reg LSB, reg←reg ÷ 2 temp←temp - 1	U	×	U	×	×	×
		mem, CL	1 1 0 1 0 0 1 W	mod 1 0 1 mem	2 to 4	temp←CL, while temp ≠ 0, the following operations are repeated: CY←(mem) LSB, (mem)←(mem) ÷ 2 temp←temp - 1	U	×	U	×	×	×
		reg, imm8	1 1 0 0 0 0 0 W	1 1 1 0 1 reg	3	temp←imm8, while temp ≠ 0, the following operations are repeated: CY←reg LSB, reg←reg ÷ 2 temp←temp - 1	U	×	U	×	×	×
		mem, imm8	1 1 0 0 0 0 0 W	mod 1 0 1 mem	3 to 5	temp←imm8, while temp ≠ 0, the following operations are repeated: CY←(mem) LSB, (mem)←(mem) ÷ 2 temp←temp - 1	U	×	U	×	×	×

Instruction Group	Mnemonic	Operand(s)	Operation Code		Bytes	Operation	Flags					
			7 6 5 4 3 2 1 0	7 6 5 4 3 2 1 0			AC	CY	V	P	S	Z
Shift instruction	SHRA	reg, 1	1 1 0 1 0 0 0 W	1 1 1 1 1 reg	2	CY←reg LSB, reg←reg ÷ 2, V←0 MSB of operand is unchanged.	U	×	0	×	×	×
		mem, 1	1 1 0 1 0 0 0 W	mod 1 1 1 mem	2 to 4	CY←(mem) LSB, (mem)←(mem) ÷ 2, V←0 MSB of operand is unchanged.	U	×	0	×	×	×
		reg, CL	1 1 0 1 0 0 1 W	1 1 1 1 1 reg	2	temp←CL, while temp ≠ 0, the following operations are repeated: CY←reg LSB, reg←reg ÷ 2 temp←temp - 1, MSB of operand is unchanged.	U	×	U	×	×	×
		mem, CL	1 1 0 1 0 0 1 W	mod 1 1 1 mem	2 to 4	temp←CL, while temp ≠ 0, the following operations are repeated: CY←(mem) LSB, (mem)←(mem) ÷ 2 temp←temp - 1, MSB of operand is unchanged.	U	×	U	×	×	×
		reg, imm8	1 1 0 0 0 0 0 W	1 1 1 1 1 reg	3	temp←imm8, while temp ≠ 0, the following operations are repeated: CY←reg LSB, reg←reg ÷ 2 temp←temp - 1, MSB of operand is unchanged.	U	×	U	×	×	×
		mem, imm8	1 1 0 0 0 0 0 W	mod 1 1 1 mem	3 to 5	temp←imm8, while temp ≠ 0, the following operations are repeated: CY←(mem) LSB, (mem)←(mem) ÷ 2 temp←temp - 1, MSB of operand is unchanged.	U	×	U	×	×	×
Rotate instruction	ROL	reg, 1	1 1 0 1 0 0 0 W	1 1 0 0 0 reg	2	CY←reg MSB, reg←reg × 2 + CY reg MSB ≠ CY: V←1 reg MSB = CY: V←0		×	×			
		mem, 1	1 1 0 1 0 0 0 W	mod 0 0 0 mem	2 to 4	CY←(mem) MSB, (mem)←(mem) × 2 + CY (mem) MSB ≠ CY: V←1 (mem) MSB = CY: V←0		×	×			
		reg, CL	1 1 0 1 0 0 1 W	1 1 0 0 0 reg	2	temp←CL, while temp ≠ 0, the following instructions are repeated: CY←reg MSB, reg←reg × 2 + CY temp←temp - 1		×	U			
		mem, CL	1 1 0 1 0 0 1 W	mod 0 0 0 mem	2 to 4	temp←CL, while temp ≠ 0, the following instructions are repeated: CY←(mem) MSB, (mem)←(mem) × 2 + CY temp←temp - 1		×	U			
		reg, imm8	1 1 0 0 0 0 0 W	1 1 0 0 0 reg	3	temp←imm8, while temp ≠ 0, the following instructions are repeated: CY←reg MSB, reg←reg × 2 + CY temp←temp - 1		×	U			
		mem, imm8	1 1 0 0 0 0 0 W	mod 0 0 0 mem	3 to 5	temp←imm8, while temp ≠ 0, the following instructions are repeated: CY←(mem) MSB, (mem)←(mem) × 2 + CY temp←temp - 1		×	U			

Instruction Group	Mnemonic	Operand(s)	Operation Code		Bytes	Operation	Flags						
			7 6 5 4 3 2 1 0	7 6 5 4 3 2 1 0			AC	CY	V	P	S	Z	
Rotate instructions	ROR	reg, 1	1 1 0 1 0 0 0 W	1 1 0 0 1 reg	2	CY←reg LSB, reg←reg ÷ 2 reg MSB←CY reg MSB ≠ bit after reg MSB: V←1 reg MSB = bit after reg MSB: V←0		×	×				
		mem, 1	1 1 0 1 0 0 0 W	mod 0 0 1 mem	2 to 4	CY←(mem) LSB, (mem)←(mem) ÷ 2 (mem) MSB←CY (mem) MSB ≠ bit after (mem) MSB: V←1 (mem) MSB = bit after (mem) MSB: V←0		×	×				
		reg, CL	1 1 0 1 0 0 1 W	1 1 0 0 1 reg	2	temp←CL, while temp ≠ 0, the following operations are repeated: CY←reg LSB, reg←reg ÷ 2 reg MSB←CY temp←temp - 1		×	U				
		mem, CL	1 1 0 1 0 0 1 W	mod 0 0 1 mem	2 to 4	temp←CL, while temp ≠ 0, the following operations are repeated: CY←(mem) LSB, (mem)←(mem) ÷ 2 (mem) MSB←CY temp←temp - 1		×	U				
		reg, imm8	1 1 0 0 0 0 0 W	1 1 0 0 1 reg	3	temp←imm8, while temp ≠ 0, the following operations are repeated: CY←reg LSB, reg←reg ÷ 2 reg MSB←CY temp←temp - 1		×	U				
		mem, imm8	1 1 0 0 0 0 0 W	mod 0 0 1 mem	3 to 5	temp←imm8, while temp ≠ 0, the following operations are repeated: CY←(mem) LSB, (mem)←(mem) ÷ 2 (mem) MSB←CY temp←temp - 1		×	U				
	ROLC	reg, 1	1 1 0 1 0 0 0 W	1 1 0 1 0 reg	2	tmpcy←CY, CY←reg MSB reg←reg × 2 + tmpcy reg MSB ≠ CY: V←1 reg MSB = CY: V←0		×	×				
		mem, 1	1 1 0 1 0 0 0 W	mod 0 1 0 mem	2 to 4	tmpcy←CY, CY←(mem) MSB (mem)←(mem) × 2 + tmpcy (mem) MSB ≠ CY: V←1 (mem) MSB = CY: V←0		×	×				
		reg, CL	1 1 0 1 0 0 1 W	1 1 0 1 0 reg	2	temp←CL, while temp ≠ 0, the following operations are repeated: tmpcy←CY, CY←reg MSB reg←reg × 2 + tmpcy temp←temp - 1		×	U				
		mem, CL	1 1 0 1 0 0 1 W	mod 0 1 0 mem	2 to 4	temp←CL, while temp ≠ 0, the following operations are repeated: tmpcy←CY, CY←(mem) MSB (mem)←(mem) × 2 + tmpcy temp←temp - 1		×	U				

Instruction Group	Mnemonic	Operand(s)	Operation Code		Bytes	Operation	Flags					
			7 6 5 4 3 2 1 0	7 6 5 4 3 2 1 0			AC	CY	V	P	S	Z
			Rotate instructions									
ROL	reg, imm8	1 1 0 0 0 0 0 W	1 1 0 1 0 reg	3	temp←imm8, while temp ≠ 0, the following instructions are repeated: tmpcy←CY, CY←reg MSB reg←reg × 2 + tmpcy temp←temp - 1	×	U					
	mem, imm8	1 1 0 0 0 0 0 W	mod 0 1 0 mem	3 to 5	temp←imm8, while temp ≠ 0, the following instructions are repeated: tmpcy←CY, CY←(mem) MSB (mem)←(mem) × 2 + tmpcy temp←temp - 1	×	U					
ROR	reg, 1	1 1 0 1 0 0 0 W	1 1 0 1 1 reg	2	tmpcy←CY, CY←reg LSB reg←reg ÷ 2 reg MSB←tmpcy reg MSB ≠ bit after reg MSB: V←1 reg MSB = bit after reg MSB: V←0	×	×					
	mem, 1	1 1 0 1 0 0 0 W	mod 0 1 1 mem	2 to 4	tmpcy←CY, CY←(mem) LSB (mem)←(mem) ÷ 2 (mem) MSB←tmpcy (mem) MSB ≠ bit after (mem) MSB: V←1 (mem) MSB = bit after (mem) MSB: V←0	×	×					
	reg, CL	1 1 0 1 0 0 1 W	1 1 0 1 1 reg	2	temp←CL, while temp ≠ 0, the following operations are repeated: tmpcy←CY, CY←reg LSB reg←reg ÷ 2 reg MSB←tmpcy temp←temp - 1	×	U					
	mem, CL	1 1 0 1 0 0 1 W	mod 0 1 1 mem	2 to 4	temp←CL, while temp ≠ 0, the following operations are repeated: tmpcy←CY, CY←(mem) LSB (mem)←(mem) ÷ 2 (mem) MSB←tmpcy temp←temp - 1	×	U					
	reg, imm8	1 1 0 0 0 0 0 W	1 1 0 1 1 reg	3	temp←imm8, while temp ≠ 0, the following operations are repeated: tmpcy←CY, CY←reg LSB reg←reg ÷ 2 reg MSB←tmpcy temp←temp - 1	×	U					
	mem, imm8	1 1 0 0 0 0 0 W	mod 0 1 1 mem	3 to 5	temp←imm8, while temp ≠ 0, the following operations are repeated: tmpcy←CY, CY←(mem) LSB (mem)←(mem) ÷ 2 (mem) MSB←tmpcy temp←temp - 1	×	U					

Instruction Group	Mnemonic	Operand(s)	Operation Code		Bytes	Operation	Flags					
			7 6 5 4 3 2 1 0	7 6 5 4 3 2 1 0			AC	CY	V	P	S	Z
Subroutine control instructions	CALL	near-proc	1 1 1 0 1 0 0 0		3	(SP - 1, SP - 2) ← PC, SP ← SP - 2 PC ← PC + disp						
		regptr16	1 1 1 1 1 1 1 1	1 1 0 1 0 reg	2	(SP - 1, SP - 2) ← PC, SP ← regptr16 SP ← SP - 2						
		memptr16	1 1 1 1 1 1 1 1	mod 0 1 0 mem	2 to 4	(SP - 1, SP - 2) ← PC, SP ← SP - 2 PC ← (memptr16)						
		far-proc	1 0 0 1 1 0 1 0		5	(SP - 1, SP - 2) ← PS, (SP - 3, SP - 4) ← PC SP ← SP - 4 PC ← seg, PC ← offset						
		memptr32	1 1 1 1 1 1 1 1	mod 0 1 1 mem	2 to 4	(SP - 1, SP - 2) ← PS, (SP - 3, SP - 4) ← PC SP ← SP - 4 PC ← (memptr32 + 2), PC ← (memptr32)						
	RET		1 1 0 0 0 0 1 1		1	PC ← (SP + 1, SP) SP ← SP + 2						
		pop-value	1 1 0 0 0 0 1 0		3	PC ← (SP + 1, SP) SP ← SP + 2, SP ← SP + pop-value						
			1 1 0 0 1 0 1 1		1	PC ← (SP + 1, SP) PS ← (SP + 3, SP + 2) SP ← SP + 4						
pop-value		1 1 0 0 1 0 1 0		3	PC ← (SP + 1, SP) PS ← (SP + 3, SP + 2) SP ← SP + 4, SP ← SP + pop-value							
Stack manipulation instruction	PUSH	mem16	1 1 1 1 1 1 1 1	mod 1 1 0 mem	2 to 4	(SP - 1, SP - 2) ← (mem16) SP ← SP - 2						
		reg16	0 1 0 1 0 reg		1	(SP - 1, SP - 2) ← reg16 SP ← SP - 2						
		sreg	0 0 0 sreg 1 1 0		1	(SP - 1, SP - 2) ← sreg SP ← SP - 2						
		PSW	1 0 0 1 1 1 0 0		1	(SP - 1, SP - 2) ← PSW SP ← SP - 2						
		R	0 1 1 0 0 0 0 0		1	Push registers on the stack						
		imm8	0 1 1 0 1 0 1 0		2	(SP - 1, SP - 2) ← imm8 sign extension SP ← SP - 2						
		imm16	0 1 1 0 1 0 0 0		3	(SP - 1, SP - 2) ← imm16 SP ← SP - 2						
		DS2*	0 0 0 0 1 1 1 1	0 0 1 1 1 1 1 0	2	(SP - 1, SP - 2) ← DS2 SP ← SP - 2						

* This instruction is newly added to the V25 or V35.

Instruction Group	Mnemonic	Operand(s)	Operation Code		Bytes	Operation	Flags					
			7 6 5 4 3 2 1 0	7 6 5 4 3 2 1 0			AC	CY	V	P	S	Z
Stack manipulation instructions	PUSH	DS3/VPC*	0 0 0 0 1 1 1 1	0 0 1 1 0 1 1 0	2	$(SP - 1, SP - 2) \leftarrow DS3/VPC$ $SP \leftarrow SP - 2$						
	POP	mem16	1 0 0 0 1 1 1 1	mod 0 0 0 mem	2 to 4	$SP \leftarrow SP + 2$ $(mem16) \leftarrow (SP - 1, SP - 2)$						
		reg16	0 1 0 1 1 reg		1	$SP \leftarrow SP + 2$ $reg16 \leftarrow (SP - 1, SP - 2)$						
		sreg	0 0 0 sreg 1 1 1		1	$SP \leftarrow SP + 2$ $sreg16 \leftarrow (SP - 1, SP - 2)$ sreg : SS, DS0, DS1						
		PSW	1 0 0 1 1 1 0 1		1	$SP \leftarrow SP + 2$ $PSW \leftarrow (SP - 1, SP - 2)$	R	R	R	R	R	R
		R	0 1 1 0 0 0 0 1		1	Pop registers from the stack						
		DS2*	0 0 0 0 1 1 1 1	0 0 1 1 1 1 1 1	2	$SP \leftarrow SP + 2$ $DS2 \leftarrow (SP - 1, SP - 2)$						
		DS3/VPC*	0 0 0 0 1 1 1 1	0 0 1 1 0 1 1 1	2	$SP \leftarrow SP + 2$ $DS3/VPC \leftarrow (SP - 1, SP - 2)$						
	PREPARE	imm16, imm8	1 1 0 0 1 0 0 0		4	Prepare New Stack Frame						
DISPOSE		1 1 0 0 1 0 0 1		1	Dispose of Stack Frame							
Branch instruction	BR	near-label	1 1 1 0 1 0 0 1		3	$PC \leftarrow PC + disp$						
		short-label	1 1 1 0 1 0 1 1		2	$PC \leftarrow PC + ext-disp8$						
		regptr16	1 1 1 1 1 1 1 1	1 1 1 0 0 reg	2	$PC \leftarrow regptr16$						
		memptr16	1 1 1 1 1 1 1 1	mod 1 0 0 mem	2 to 4	$PC \leftarrow (memptr16)$						
		far-label	1 1 1 0 1 0 1 0		5	$PS \leftarrow seg$ $PC \leftarrow offset$						
		memptr32	1 1 1 1 1 1 1 1	mod 1 0 1 mem	2 to 4	$PS \leftarrow (memptr32 + 2)$ $PC \leftarrow (memptr32)$						

* This instruction is newly added to the V25 or V35.

Phase-out/Discontinued

Instruction Group	Mnemonic	Operand(s)	Operation Code		Bytes	Operation	Flags					
			7 6 5 4 3 2 1 0	7 6 5 4 3 2 1 0			AC	CY	V	P	S	Z
Conditional branch instructions	BV	short-label	0 1 1 1 0 0 0 0		2	if V = 1 PC←PC + ext-disp8						
	BNV	short-label		0 0 0 1	2	if V = 0 PC←PC + ext-disp8						
	BC BL	short-label		0 0 1 0	2	if CY = 1 PC←PC + ext-disp8						
	BNC BNL	short-label		0 0 1 1	2	if CY = 0 PC←PC + ext-disp8						
	BE BZ	short-label		0 1 0 0	2	if Z = 1 PC←PC + ext-disp8						
	BNE BNZ	short-label		0 1 0 1	2	if Z = 0 PC←PC + ext-disp8						
	BNH	short-label		0 1 1 0	2	if CY ∨ Z = 1 PC←PC + ext-disp8						
	BH	short-label		0 1 1 1	2	if CY ∨ Z = 0 PC←PC + ext-disp8						
	BN	short-label		1 0 0 0	2	if S = 1 PC←PC + ext-disp8						
	BP	short-label		1 0 0 1	2	if S = 0 PC←PC + ext-disp8						
	BPE	short-label		1 0 1 0	2	if P = 1 PC←PC + ext-disp8						
	BPO	short-label		1 0 1 1	2	if P = 0 PC←PC + ext-disp8						
	BLT	short-label		1 1 0 0	2	if S ∨ V = 1 PC←PC + ext-disp8						
	BGE	short-label		1 1 0 1	2	if S ∨ V = 0 PC←PC + ext-disp8						
	BLE	short-label		1 1 1 0	2	if (S ∨ Z) ∨ Z = 1 PC←PC + ext-disp8						
	BGT	short-label		▼ 1 1 1 1	2	if (S ∨ V) ∨ Z = 0 PC←PC + ext-disp8						
	DBNZNE	short-label		1 1 1 0 0 0 0 0	2	CW = CW - 1 if Z = 0 and CW ≠ 0 PC←PC + ext-disp8						
	DBNZE	short-label			0 0 0 1	2	CW = CW - 1 if Z = 1 and CW ≠ 0 PC←PC + ext-disp8					
	DBNZ	short-label			0 0 1 0	2	CW = CW - 1 if CW ≠ 0 PC←PC + ext-disp8					
	BCWZ	short-label		▼ 0 0 1 1	2	if CW = 0 PC←PC + ext-disp8						
BTCLR ^{*1}	sfr, imm3, short-label	0 0 0 0 1 1 1 1	1 0 0 1 1 1 0 0	5	If (sfr) bit No. imm3 = 1: PC←PC + ext-disp8, (sfr) bit No.imm3←0							
BTCLRL ^{*2}	sfrl, imm3, short-label	0 0 0 0 1 1 1 1	1 0 0 1 1 1 0 1	5	If (sfrl) bit No. imm3 = 1: PC←PC + ext-disp8, (sfrl) bit No.imm3←0							

* 1. This instruction is newly added to the V20 or V30.
 2. This instruction is newly added to the V25 or V35.

Instruction Group	Mnemonic	Operand(s)	Operation Code		Bytes	Operation	Flags					
			7 6 5 4 3 2 1 0	7 6 5 4 3 2 1 0			AC	CY	V	P	S	Z
Interrupt instructions	BRK	3	1 1 0 0 1 1 0 0		1	(SP - 1, SP - 2)←PSW, (SP - 3, SP - 4)←PS (SP - 5, SP - 6)←PC, SP←SP - 6 IE←0, BRK←0 PS←(15, 14), PC←(13, 12)						
		imm8 (≠ 3)	1 1 0 0 1 1 0 1		2	(SP - 1, SP - 2)←PSW, (SP - 3, SP - 4)←PS (SP - 5, SP - 6)←PC, SP←SP - 6 IE←0, BRK←0 PS←(n × 4 + 3, n × 4 + 2), PC←(n × 4 + 1, n × 4) n = imm8						
	BRKV		1 1 0 0 1 1 1 0		1	If V = 1: (SP - 1, SP - 2)←PSW, (SP - 3, SP - 4)←PS (SP - 5, SP - 6)←PC, SP←SP - 6 IE←0, BRK←0 PS←(19, 18), PC←(17, 16)						
	RETI		1 1 0 0 1 1 1 1		1	PC←(SP + 1, SP), PS←(SP + 3, SP + 2) PSW←(SP + 5, SP + 4), SP←SP + 6	R	R	R	R	R	R
	RETRBI*		0 0 0 0 1 1 1 1	1 0 0 1 0 0 0 1	2	PC←Value of PC save area in currently selected bank register, PSW←Value of PSW save area in currently selected bank register	R	R	R	R	R	R
	FINT*		0 0 0 0 1 1 1 1	1 0 0 1 0 0 1 0	2	Indicates to interrupt controller incorporated in CPU that interrupt servicing has ended.						
	CHKIND	reg, mem32	0 1 1 0 0 0 1 0	mod reg mem	2 to 4	If (mem32) > reg16 or (mem32 + 2) < reg16 (SP - 1, SP - 2)←PSW, (SP - 3, SP - 4)←PS (SP - 5, SP - 6)←PC, SP←SP - 6 IE←0, BRK←0 PS←(23, 22), PC←(21, 20)						
Register bank switching instructions	BRKCS*	reg16	0 0 0 0 1 1 1 1	0 0 1 0 1 1 0 1	3	temp←PSW RB3 to 0←reg16 low-order 4 bits, IE←0, BRK←0 PSW save area in newly selected register bank←temp PC save area in newly selected register bank←PC						
			1 1 0 0 0 reg									
	TSKSW*	reg16	0 0 0 0 1 1 1 1	1 0 0 1 0 1 0 0	3	PSW save area in currently selected register bank←PSW PC save area in currently selected register bank←PC RB3-0←reg16 low-order 4 bits PSW←Value of PSW save area in newly selected register bank PC←Value of PC save area in newly selected register bank	×	×	×	×	×	×
			1 1 1 1 1 reg									
Dedicated fax instructions	ALBIT		0 0 0 0 1 1 1 1	1 0 0 1 1 0 1 0	2	If CH + CL ≥ 16: BW, DW→DS1:IY output to transmit buffer If CH + CL < 16: CH + CL→CH, BW, DW→BW Part exceeding 16 bits: CH+CL-16→CH, BW, DW→BW	U	×	U	U	U	×
	COLTRP		0 0 0 0 1 1 1 1	1 0 0 1 1 0 1 1	2	Stores 1 line pixel data change point information in change point table (start white run length).						
	MHENC		0 0 0 0 1 1 1 1	1 0 0 1 0 0 1 1	2	Generates MH code from change point table.	U	×	U	U	U	×
	MRENC		0 0 0 0 1 1 1 1	1 0 0 1 0 1 1 1	2	Generates MR code from change point table.	U	×	U	U	U	×

* This instruction is newly added to the V20 or V30.

Phase-out/Discontinued

Instruction Group	Mnemonic	Operand(s)	Operation Code		Bytes	Operation	Flags						
			7 6 5 4 3 2 1 0	7 6 5 4 3 2 1 0			AC	CY	V	P	S	Z	
Dedicated fax instructions	SCEOL		0 0 0 0 1 1 1 1	0 1 1 1 1 0 0 0	2	"EOL" detection in MH/MR code	U	×	U	U	U	×	
	GETBIT		0 0 0 0 1 1 1 1	0 1 1 1 1 0 0 1	2	Fetches pixel data start bit and sets it to CY flag.	U	×	U	U	U	×	
	MHDEC		0 0 0 0 1 1 1 1	0 1 1 1 1 1 0 0	2	Generates change point table from MH code.	U	×	U	U	U	×	
	MRDEC		0 0 0 0 1 1 1 1	0 1 1 1 1 1 0 1	2	Generates change point table from MR code.	U	×	U	U	U	×	
	CNVTRP		0 0 0 0 1 1 1 1	0 1 1 1 1 0 1 0	2	Converts 1 line change point information in change point table to pixel data.							
CPU control instructions	HALT		1 1 1 1 0 1 0 0		1	CPU Halt							
	STOP*1		0 0 0 0 1 1 1 1	1 0 0 1 1 1 1 0	2	CPU Stop							
	POLL		1 0 0 1 1 0 1 1		1	Poll and wait							
	DI		1 1 1 1 1 0 1 0		1	IE←0							
	EI		1 1 1 1 1 0 1 1		1	IE←1							
	BUSLOCK		1 1 1 1 0 0 0 0		1	Bus Lock Prefix							
	FPO1	fp-op		1 1 0 1 1 X X X	1 1 Y Y Y Z Z Z	2	(SP - 1, SP - 2)←PSW, (SP - 3, SP - 4)←PS						
		fp-op, mem		1 1 0 1 1 X X X	mod Y Y Y mem	2 to 4	(SP - 5, SP - 6)←PC - x*6, SP←SP - 6						
	FPO2	fp-op		0 1 1 0 0 1 1 X	1 1 Y Y Y Z Z Z	2	IE←0, BRK←0						
		fp-op, mem		0 1 1 0 0 1 1 X	mod Y Y Y mem	2 to 4	PC←(01DH; 01CH), PS←(01FH, 01EH)						
NOP		1 0 0 1 0 0 0 0		1	No Operation								
*3	RSTWDT*2	imm8, imm8	0 0 0 0 1 1 1 1	1 0 0 1 0 1 1 0	4	When imm8 = imm8' WDM register←imm8 When imm8 ≠ imm8' (SP - 1, SP - 2)←PSW, (SP - 3, SP - 4)←PS (SP - 5, SP - 6)←PC - x*6, SP←SP - 6 IE←0, BRK←0 PC←(20H, 21H), PS←(22H, 23H)							
		imm8		imm8									
	*4		0 0 1 sreg 1 1 0		1	Segment override prefix							
	DS2: *2		0 1 1 0 0 0 1 1		1	Extended segment override prefix							
	DS3: *2		1 1 0 1 0 1 1 0		1	Extended segment override prefix							
*5	IRAM: *2		1 1 1 1 0 0 0 1		1	Register file override prefix							

- * 1. This instruction is newly added to the V20 or V30.
 2. This instruction is newly added to the V25 or V35.
 3. Watchdog timer manipulation instruction
 4. Four kinds: DS0:, DS1:, PS:, SS:
 5. Register file space access override prefix instruction
 6. x: Number of instruction bytes + number of prefixes

18. ELECTRICAL SPECIFICATIONS

This section shows the electrical specifications of the V55PI™ using the three categories below.

μ PD70433GD/R/GJ-12: μ PD70433-12

μ PD70433GD/R/GJ-16: μ PD70433-16

ABSOLUTE MAXIMUM RATINGS ($T_A = 25\text{ }^\circ\text{C}$)

PARAMETER	SYMBOL	TEST CONDITIONS	RATINGS	UNIT
Supply voltage	V_{DD}		-0.5 to +7.0	V
	AV_{DD}		-0.5 to $V_{DD} + 0.5$	V
	AV_{SS}		-0.5 to +0.5	V
	AV_{REF}		-0.5 to $AV_{DD} + 0.3$	V
Input voltage	V_I		-0.5 to $V_{DD} + 0.5$	V
Output voltage	V_O		-0.5 to $V_{DD} + 0.5$	V
Output current low	I_{OL}	One pin	4.0	mA
		Total of all pins	100	mA
Output current high	I_{OH}	One pin	-1.0	mA
		Total of all pins	-20	mA
Operating ambient temperature	T_A		-40 to +85	$^\circ\text{C}$
Storage temperature	T_{stg}		-65 to +150	$^\circ\text{C}$

Notes 1. The IC product output (or input/output) pins should not be directly connected between V_{DD} , V_{CC} or GND. However, direct connection between the open-drain pins or between the open collector pins is possible. Direct connection is also possible for an external circuit via timing design that avoids collision of output at pins which become high impedance.

2. Exceeding the absolute maximum ratings even in one of the parameters even for an instant may affect the product quality.

That is, the absolute maximum ratings are rated values at which the product is on the verge of suffering physical damage, and therefore avoid using the product close to the rated values. The specifications and conditions shown in the DC characteristics and AC characteristics comprise the normal operation and guaranteed quality range.

DC Characteristics (T_A = -40 to +85 °C, V_{DD} = +5.0 V ± 10 %)

PARAMETER	SYMBOL	TEST CONDITIONS	MIN.	TYP.	MAX.	UNIT
Input voltage low	V _{IL1}	*1	0		0.8	V
	V _{IL2}	*2	0		0.2V _{DD}	V
Input voltage high	V _{IH1}	*1	2.2		V _{DD}	V
	V _{IH2}	*2	0.8V _{DD}		V _{DD}	V
Schmitt-triggered input threshold voltage	V _T ⁺	*3, rise		3.3		V
	V _T ⁻	*3, fall		1.6		V
Schmitt-triggered input hysteresis width	V _T ⁺ - V _T ⁻	*3	0.5			V
Output voltage low	V _{OL}	I _{OL} = 2.0 mA			0.45	V
Output voltage high	V _{OH}	I _{OH} = -0.4 mA	V _{DD} - 1.0			V
Input leakage current	I _{LI}	0 V ≤ V _i ≤ V _{DD}			±10	μA
Output leakage current	I _{LO}	0 V ≤ V _o ≤ V _{DD}			±10	μA
V _{DD} supply current*4	I _{DD1}	Operating mode		5.4f _x + 30	5.4f _x + 50	mA
	I _{DD2}	HALT mode		3.7 f _x	3.7f _x + 20	mA
	I _{DD3}	STOP mode		10	50	μA
AV _{DD} supply current	A _{DD1}	Operating mode		1.5	2.5	mA
	A _{DD2}	HALT mode		0.6	1	mA
	A _{DD3}	STOP mode		10	50	μA

* 1. Other than *2

2. RESET, P10/NMI, X1, P11/INTP0 to P16/INTP5, P30/TxD0/SO0/SB0, P31/RxD0/SB1/SI0, P32/TxC/SCK0, P33/CTS0, P35/RxD1/SI1, P36/SCK1/CTS1

3. RESET, P10/NMI, P11/INTP0 to P16/INTP5

4. The unit for the constants 5.4 and 3.7 is mA/MHz.

CAPACITANCE (T_A = 25 °C, V_{DD} = 0 V)

PARAMETER	SYMBOL	TEST CONDITIONS	MIN.	TYP.	MAX.	UNIT
Input capacitance	C _I	f _c = 1 MHz Unmeasured pins are returned to 0 V.			10	pF
Output capacitance	C _O				20	pF
I/O capacitance	C _{IO}				20	pF

OPERATING CONDITIONS

PART NUMBER	INT. CLOCK FREQUENCY	OPERATING TEMPERATURE (T _A)	SUPPLY VOLTAGE (V _{DD})
μPD70433-12	0.25 MHz ≤ f _x ≤ 12.5 MHz	-40 to +85 °C	+5.0 V ± 10 %
μPD70433-16	0.25 MHz ≤ f _x ≤ 12.5 MHz		

RECOMMENDED OSCILLATION CIRCUIT

The circuit shown below is recommended for a clock input.

(1) Ceramic resonator connection ($T_A = -40$ to $+85$ °C ± 10 %, $V_{DD} = 5$ V ± 10 %)

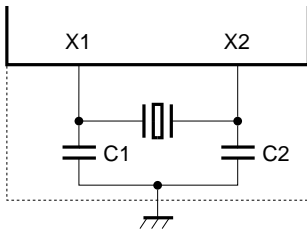

MANUFACTURER	OSCILLATOR FREQUENCY f_{xx} [MHz]	PRODUCT NAME	RECOMMENDED CONSTANTS	
			C1 [pF]	C2 [pF]
Murata Mfg. Co., Ltd.	25	CSA25.00MXZ040	5	5
	32	CSA32.00MXZ040	3	3

- Notes 1. The oscillator should be located as close to the X1 and X2 pins as possible.
- 2. Other signal lines should not cross the dotted area.
- 3. When matching the μPD70433 with a resonator, careful evaluation is required.

(2) Crystal resonator connection

(a) Basic-wave recommended condition ($T_A = -10$ to $+70$ °C, $V_{DD} = 5$ V ± 10 %)

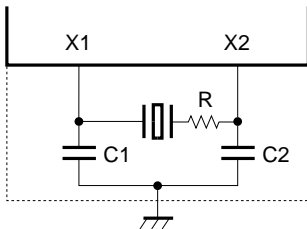

MANUFACTURER	OSCILLATOR FREQUENCY f_{xx} [MHz]	PRODUCT NAME	RECOMMENDED CONSTANTS		
			C1 [pF]	C2 [pF]	R [Ω]
★ Kinseki	25	HC-49/U-S	5	5	200
			10	10	-

- Notes 1. The oscillator should be located as close to the X1 and X2 pins as possible.
- 2. Other signal lines should not cross the dotted area.
- 3. When matching the μPD70433 with a resonator, careful evaluation is required.

(b) 3rd-overtone recommended condition ($T_A = -20$ to $+70$ °C, $V_{DD} = 5\text{ V} \pm 10\%$)

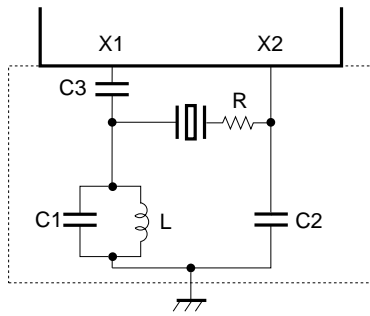

MANUFACTURER	OSCILLATOR FREQUENCY f_{xx} [MHz]	PRODUCT NAME	RECOMMENDED CONSTANTS				
			C1 [pF]	C2 [pF]	C3 [pF]	L [μ H]	R [Ω]
Kinseki	25	HC-49/U	15	15	1000	3.3	100
	32		10	5	1000	3.3	100

★

- Notes**
1. The oscillator should be located as close to the X1 and X2 pins as possible.
 2. Other signal lines should not cross the dotted area.
 3. When matching the μPD70433 with a resonator, careful evaluation is required.

(3) External clock input

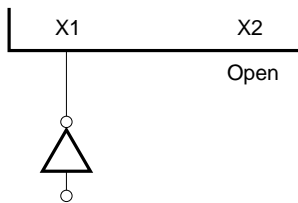

AC CHARACTERISTICS (T_A = -40 to +85 °C, V_{DD} = +5.0 V ± 10 %)

(1) μPD70433-12

★

PARAMETER	SYMBOL	TEST CONDITIONS	MIN.	MAX.	UNIT
X1 input cycle time	① t _{CYX}		40	250	ns
X1 input high-level width	② t _{WXH}		15		ns
X1 input low-level width	③ t _{WXL}		15		ns
X1 input rise time	④ t _{XR}			10	ns
X1 input fall time	⑤ t _{XF}			10	ns
CLKOUT output cycle time	⑥ t _{CYK}		80	4000	ns
CLKOUT output high-level width	⑦ t _{WKH}		0.5T - 5		ns
CLKOUT output low-level width	⑧ t _{WKL}		0.5T - 5		ns
CLKOUT output rise time	⑨ t _{KR}			7	ns
CLKOUT output fall time	⑩ t _{KF}			7	ns
Input rise time	⑪ t _{IR1}	*1		10	ns
	⑫ t _{IR2}	*2		20	ns
Input fall time	⑬ t _{IF1}	*1		10	ns
	⑭ t _{IF2}	*2		20	ns
Output rise time	⑮ t _{OR}			10	ns
Output fall time	⑯ t _{OF}			10	ns
CLKOUT delay time from X1↑	⑰ t _{DXK}	X2: open		18	ns
Address delay time from CLKOUT↑	⑱ t _{DKA}		5	27	ns
Address hold time (from CLKOUT↑)	⑲ t _{HKA1}		0		ns
	⑳ t _{HKA2}		0		ns
Address float delay time from CLKOUT↑	㉑ t _{FKA}		t _{HKA1}	36	ns
Address setup time (to $\overline{\text{ASTB}}\downarrow$)	㉒ t _{SAST}		(n + 0.5)T - 25		ns
Address hold time (from $\overline{\text{ASTB}}\downarrow$)	㉓ t _{HSTA}		0.5T - 15		ns
$\overline{\text{ASTB}}\downarrow$ delay time from CLKOUT↓	㉔ t _{DKSTL}		0	22	ns
$\overline{\text{ASTB}}\uparrow$ delay time from CLKOUT↓	㉕ t _{DKSTH}		0	22	ns
$\overline{\text{ASTB}}$ high-level width	㉖ t _{WSTH}		(n + 1)T - 15		ns
$\overline{\text{RD}}\downarrow$ delay time from CLKOUT↑	㉗ t _{DKRL}		0	22	ns
$\overline{\text{RD}}\uparrow$ delay time from CLKOUT↑	㉘ t _{DKRH}		0	22	ns
$\overline{\text{RD}}$ low-level width	㉙ t _{WR}		(N + 1.5)T - 15		ns
$\overline{\text{RD}}\downarrow$ delay time from address float	㉚ t _{FARL}		0		ns
Address delay time from $\overline{\text{RD}}\uparrow$	㉛ t _{DRA}		0.5T		ns

n : Number of address wait states
 N : Number of data wait states
 T : t_{CYK}

- * 1. Other than *2
- 2. RESET, P10 NMI, X1, P11/INTP0 to P16/INTP5, P30/TxD0/SO0/SB0, P31/RxD0/SB1/SI0, P32/TxC/SCK0, P33/CTS0, P35/RxD1/SI1, P36/SCK1/CTS1

Remark Numbers in the Symbol column correspond to numbers in the timing charts.

PARAMETER	SYMBOL	TEST CONDITIONS	MIN.	MAX.	UNIT
$\overline{ASTB}\uparrow$ delay time from $\overline{RD}\uparrow$, $\overline{IORD}\uparrow$	(119) tDRSTH		0		ns
$\overline{RD}\uparrow$, $\overline{IORD}\uparrow$ delay time from $\overline{WRL}\uparrow$, $\overline{WRH}\uparrow$, $\overline{IOWR}\uparrow$	(120) tDWRH		0		ns
$\overline{DEX}\downarrow$ delay time from $\overline{CLKOUT}\downarrow$	(31) tDKDX		0	27	ns
\overline{DEX} hold time (from $\overline{CLKOUT}\downarrow$)	(32) tHKDX		0		ns
Data input setup time (to $\overline{CLKOUT}\downarrow$)	(33) tSDK		11		ns
Data input hold time (from $\overline{CLKOUT}\downarrow$)	(34) tHKDR		0		ns
$\overline{WR}\downarrow$ delay time from $\overline{CLKOUT}\downarrow$	(35) tDKWL		0	22	ns
$\overline{WR}\uparrow$ delay time from $\overline{CLKOUT}\downarrow$	(36) tDKWH		0	22	ns
\overline{WR} low-level width	(37) tWWL		(N + 1)T - 12		ns
Data output delay time from $\overline{CLKOUT}\uparrow$	(38) tDKD		3	27	ns
Data output hold time (from $\overline{CLKOUT}\downarrow$)	(39) tHKDW		0		ns
$\overline{ASTB}\uparrow$ delay time from $\overline{WR}\uparrow$	(40) tDWSTH		0		ns
$\overline{RAS}\downarrow$ delay time from $\overline{CLKOUT}\uparrow$	(41) tDKRAL		nT	nT + 22	ns
$\overline{RAS}\uparrow$ delay time from $\overline{CLKOUT}\uparrow$	(42) tDKRAH		0	22	ns
\overline{RAS} high-level width	(43) tWRAH		(n + 1)T - 15		ns
$\overline{RAS}\uparrow$ delay time from $\overline{WRH}\downarrow$, $\overline{WRL}\downarrow$	(121) tDWRAH		(N + 0.5)T - 10		ns
Address setup time (to $\overline{RAS}\downarrow$)	(122) tSARAL		nT - 12		ns
READY setup time (to $\overline{CLKOUT}\downarrow$)	(44) tSRYHK		18		ns
READY hold time (from $\overline{CLKOUT}\downarrow$)	(45) tHKRYL		12		ns
READY setup time (to $\overline{CLKOUT}\downarrow$)	(46) tSRYLK		18		ns
READY hold time (from $\overline{CLKOUT}\downarrow$)	(47) tHKRYH		12		ns
\overline{RESET} low-level width	(48) tWRSL1	STOP release/power-on reset	30		ms
	(49) tWRSL2	System reset	1000 + 2T		ns
NMI high-level width	(50) tWNIH		5		μs
NMI low-level width	(51) tWNIL		5		μs
INTPm setup time (to $\overline{CLKOUT}\downarrow$)	(52) tSIQK	m = 0 to 5	25		ns
INTPm high-level width	(53) tWIQH	m = 0 to 5	10T		ns
INTPm low-level width	(54) tWQIL	m = 0 to 5	10T		ns
\overline{POLL} setup time (to $\overline{CLKOUT}\downarrow$)	(55) tSPLK		25		ns
HLDRQ setup time (to $\overline{CLKOUT}\downarrow$)	(56) tSHQK		25		ns
$\overline{HLDAK}\downarrow$ delay time from $\overline{CLKOUT}\uparrow$	(57) tDKHA		0	27	ns
$\overline{HLDAK}\downarrow$ delay time from bus float	(58) tFCHA		0		ns
Bus output delay time from $\overline{HLDAK}\uparrow$	(59) tDHAC		T - 22.5		ns

n : Number of address wait states

N : Number of data wait states

T : t_{cyk}

Remark Numbers in the Symbol column correspond to numbers in the timing charts.

PARAMETER	SYMBOL	TEST CONDITIONS	MIN.	MAX.	UNIT
$\overline{\text{HLDAK}}\uparrow$ delay time from $\text{HLDRQ}\downarrow$	(60) t_{DHQA}		0.5T – 15	3.5T + 35	ns
Bus output delay time from $\text{HLDRQ}\downarrow$	(61) t_{DHQC}		0.5T + 45		ns
HLDRQ low-level width	(62) t_{WHQL}		2T		ns
$\overline{\text{HLDAK}}$ low-level width	(63) t_{WHAL}		3T – 10		ns
$\overline{\text{BUSLOCK}}\uparrow$ delay time from $\text{CLKOUT}\uparrow$	(64) t_{DKBL}		0	27	ns
DMARQm setup time (to $\text{CLKOUT}\downarrow$)	(65) t_{SDQK}	Except demand release mode; m = 0, 1	25		ns
DMARQm high-level width	(66) t_{WDQH}	Except demand release mode; m = 0, 1	2T		ns
DMARQm low-level width	(67) t_{WDQL}	Except demand release mode; m = 0, 1	2T		ns
DMARQm setup time (to $\text{CLKOUT}\uparrow$)	(68) t_{SKDQ}	Demand release mode; m = 0 or 1		5	ns
DMARQm low-level hold time (from $\text{CLKOUT}\downarrow$)	(69) t_{HKDQ}	Demand release mode; m = 0 or 1	12		ns
$\overline{\text{DMAAKm}}\downarrow$ delay time from $\text{CLKOUT}\uparrow$	(70) t_{DKDA}	m = 0 or 1	0	27	ns
$\overline{\text{DMAAKm}}$ low-level width	(71) t_{WDAL}	m = 0 or 1	$(3 + n + N)T - 10$		ns
$\overline{\text{TCEm}}\downarrow$ delay time from $\text{CLKOUT}\uparrow$	(72) t_{DKTE}	m = 0 or 1	0	27	ns
$\overline{\text{TCEm}}$ low-level width	(73) t_{WTCL}	m = 0 or 1	T – 10		ns
TOUT high-level width	(74) t_{WTOH}		8T – 10		ns
TOUT low-level width	(75) t_{WTOL}		8T – 10		ns
$\overline{\text{WDTOUT}}$ low-level width	(76) t_{WWTL}		32T – 10		ns
$\overline{\text{SCK}}$ cycle time	(77) t_{CYSK}	Input	8T		ns
		Output	8T – 10		ns
$\overline{\text{SCK}}$ high-level width	(78) t_{WSKH}	Input	4T – 10		ns
		Output	4T – 10		ns
$\overline{\text{SCK}}$ low-level width	(79) t_{WSKL}	Input	4T – 10		ns
		Output	4T – 10		ns
SI, SB setup time (to $\overline{\text{SCK}}\uparrow$)	(80) t_{SSSK}		50		ns
SI, SB hold time (from $\overline{\text{SCK}}\uparrow$)	(81) t_{HSKS}		150		ns
SO, SB delay time from $\overline{\text{SCK}}\downarrow$	(82) t_{DSKSB1}	IOE mode (CMOS push-pull output)	0	90	ns
	(83) t_{DSKSB2}	SBI mode (open-drain output, RL = 1 kΩ)	0	190	ns
SB high-level hold time (from $\overline{\text{SCK}}\uparrow$)	(84) t_{HSKSB}	SBI mode	4T		ns
SB low-level setup time (to $\overline{\text{SCK}}\downarrow$)	(85) t_{SSBSK}		4T		ns
SB high-level width	(86) t_{WSBH}		4T		ns
SB low-level width	(87) t_{WSBL}		4T		ns

n : Number of address wait states
 N : Number of data wait states
 T : t_{CYK}

Remark Numbers in the Symbol column correspond to numbers in the timing charts.

PARAMETER	SYMBOL	TEST CONDITIONS	MIN.	MAX.	UNIT	
$\overline{\text{CTS}}$ high-level width	(88) t_{WCTH}		2T		ns	
$\overline{\text{CTS}}$ low-level width	(89) t_{WCTL}		2T		ns	
Transmit/receive data cycle	(90) t_{CYD}	UART	32T		ns	
TxC output clock cycle	(91) t_{CYC}	UART	32T		ns	
TxC output clock high-level width	(92) t_{WCH}		16T – 10		ns	
TxC output clock low-level width	(93) t_{WCL}		16T – 10		ns	
TxD delay time from $\overline{\text{TxC}}\downarrow$	(94) t_{DTCTD}		0	90	ns	
TxD delay time from $\overline{\text{CTS}}\downarrow$	(95) t_{DCTTD}			2 t_{CYC}	ns	
$\overline{\text{DATASTB}}$ setup time	(96) t_{SDSK}		Input mode	25		ns
$\overline{\text{DATASTB}}$ low-level width	(97) t_{WDSL1}		Input mode	2T		ns
	(98) t_{WDSL2}	Output mode	2T – 10	512T	ns	
PD setup time (to $\overline{\text{DATASTB}}\downarrow$)	(99) t_{SPDDS1}	Input mode ($\overline{\text{DATASTB}}\downarrow$ latch mode)	45		ns	
PD hold time (from $\overline{\text{DATASTB}}\downarrow$)	(100) t_{HDSPD1}		4T		ns	
BUSY delay time from $\overline{\text{DATASTB}}\downarrow$	(101) t_{DDBY1}			4T	ns	
PD setup time (to $\overline{\text{DATASTB}}\uparrow$)	(102) t_{SPDDS2}	Input mode ($\overline{\text{DATASTB}}\uparrow$ latch mode)	45		ns	
PD hold time (from $\overline{\text{DATASTB}}\uparrow$)	(103) t_{HDSPD2}		4T		ns	
BUSY delay time from $\overline{\text{DATASTB}}\uparrow$	(104) t_{DDBY2}			4T	ns	
$\overline{\text{DATASTB}}\downarrow$ delay time from PD	(105) t_{DPDSSL}	Output mode	2T – 30	512T	ns	
$\overline{\text{DATASTB}}$ setup time (to $\overline{\text{ACK}}\downarrow$)	(106) t_{SDSAK}		0		ns	
$\overline{\text{ACK}}$ input low-level width	(107) t_{WAKL}		2T		ns	
$\overline{\text{DATASTB}}$ setup time (to $\overline{\text{BUSY}}\uparrow$)	(108) t_{SDSBY}		0		ns	
BUSY input high-level width	(109) t_{WBYH}		2T		ns	
Port output delay time (from $\overline{\text{CLKOUT}}\downarrow$)	(123) t_{DKP}		8	50	ns	
Port input setup time (to $\overline{\text{CLKOUT}}\downarrow$)	(124) t_{SPK}		25		ns	
Port input hold time (from $\overline{\text{CLKOUT}}\downarrow$)	(125) t_{HKP}	16		ns		
DMARQ _m high-level hold time (from $\overline{\text{ASTB}}\downarrow$)	(126) t_{HSTDQ}	Demand release mode; m = 0 or 1	0		ns	
$\overline{\text{REFRQ}}\downarrow$ delay time from $\overline{\text{CLKOUT}}\uparrow$	(127) t_{DKREL}		0	25	ns	
$\overline{\text{REFRQ}}\uparrow$ delay time from $\overline{\text{CLKOUT}}\uparrow$	(128) t_{DKREH}		0	25	ns	
$\overline{\text{RAS}}$ delay time from $\overline{\text{REFRQ}}\downarrow$	(129) t_{DRERA}		nT – 5		ns	
$\overline{\text{RD}}\downarrow$ delay time from $\overline{\text{ASTB}}\downarrow$	(130) t_{DSTLRL}		0.5T – 5		ns	

n : Number of address wait states
 N : Number of data wait states
 T : t_{CYC}

Remark Numbers in the Symbol column correspond to numbers in the timing charts.

(2) μPD70433-16

PARAMETER	SYMBOL	TEST CONDITIONS	MIN.	MAX.	UNIT
X1 input cycle time	① t _{CYX}		31.25	250	ns
X1 input high-level width	② t _{WXH}		12		ns
X1 input low-level width	③ t _{WXL}		12		ns
X1 input rise time	④ t _{XR}			5	ns
X1 input fall time	⑤ t _{XF}			5	ns
CLKOUT output cycle time	⑥ t _{CYK}		62.5	4000	ns
CLKOUT output high-level width	⑦ t _{WKH}		0.5T – 5		ns
CLKOUT output low-level width	⑧ t _{WKL}		0.5T – 5		ns
CLKOUT output rise time	⑨ t _{KR}			5	ns
CLKOUT output fall time	⑩ t _{KF}			5	ns
Input rise time	⑪ t _{IR1}	*1		10	ns
	⑫ t _{IR2}	*2		20	ns
Input fall time	⑬ t _{IF1}	*1		10	ns
	⑭ t _{IF2}	*2		20	ns
Output rise time	⑮ t _{OR}			10	ns
Output fall time	⑯ t _{OF}			10	ns
CLKOUT delay time from X1↓	⑰ t _{DXK}	X2: open		18	ns
Address delay time from CLKOUT↑	⑱ t _{DKA}		5	27	ns
Address hold time (from CLKOUT↑)	⑲ t _{HKA1}		0		ns
	⑳ t _{HKA2}		0		ns
Address float delay time from CLKOUT↑	㉑ t _{FKA}		t _{HKA1}	36	ns
Address setup time (to $\overline{\text{ASTB}}\downarrow$)	㉒ t _{SAST}		(n + 0.5)T – 25		ns
Address hold time (from $\overline{\text{ASTB}}\downarrow$)	㉓ t _{HSTA}		0.5T – 15		ns
$\overline{\text{ASTB}}\downarrow$ delay time from CLKOUT↓	㉔ t _{DKSTL}		0	22	ns
$\overline{\text{ASTB}}\uparrow$ delay time from CLKOUT↓	㉕ t _{DKSTH}		0	22	ns
$\overline{\text{ASTB}}$ high-level width	㉖ t _{WSTH}		(n + 1)T – 15		ns
$\overline{\text{RD}}\downarrow$ delay time from CLKOUT↑	㉗ t _{DKRL}		0	22	ns
$\overline{\text{RD}}\uparrow$ delay time from CLKOUT↓	㉘ t _{DKRH}		0	22	ns
$\overline{\text{RD}}$ low-level width	㉙ t _{WRL}		(N + 1.5)T – 15		ns
$\overline{\text{RD}}\downarrow$ delay time from address float	㉚ t _{FARL}		0		ns
Address delay time from $\overline{\text{RD}}\uparrow$	㉛ t _{DRA}		0.5T		ns

n : Number of address wait states

N : Number of data wait states

T : t_{CYK}

* 1. Other than *2

2. $\overline{\text{RESET}}$, P10 NMI, X1, P11/INTP0 to P16/INTP5, P30/TxD0/SO0/SB0, P31/RxD0/SB1/SI0, P32/TxC/SKC0, P33/CTS0, P35/RxD1/SI1, P36/SCK1/CTS1

Remark Numbers in the Symbol column correspond to numbers in the timing charts.

PARAMETER	SYMBOL	TEST CONDITIONS	MIN.	MAX.	UNIT
$\overline{ASTB}\uparrow$ delay time from $\overline{RD}\uparrow, \overline{IORD}\uparrow$	(119) tDRSTH		0		ns
$\overline{RD}\uparrow, \overline{IORD}\uparrow$ delay time from $\overline{WRL}\uparrow, \overline{WRH}\uparrow, \overline{IOWR}\uparrow$	(120) tDWRH		0		ns
$\overline{DEX}\downarrow$ delay time from CLKOUT \downarrow	(31) tDKDX		0	27	ns
\overline{DEX} hold time (from CLKOUT \downarrow)	(32) tHKDX		0		ns
Data input setup time (to CLKOUT \downarrow)	(33) tSDK		11		ns
Data input hold time (from CLKOUT \downarrow)	(34) tHKDR		0		ns
$\overline{WR}\downarrow$ delay time from CLKOUT \downarrow	(35) tDKWL		0	22	ns
$\overline{WR}\uparrow$ delay time from CLKOUT \downarrow	(36) tDKWH		0	22	ns
\overline{WR} low-level width	(37) tWWL		(N + 1)T - 12		ns
Data output delay time from CLKOUT \uparrow	(38) tDKD		3	27	ns
Data output hold time (from CLKOUT \downarrow)	(39) tHKDW		0		ns
$\overline{ASTB}\uparrow$ delay time from $\overline{WR}\uparrow$	(40) tDWSTH		0		ns
$\overline{RAS}\downarrow$ delay time from CLKOUT \uparrow	(41) tDKRAL		nT	nT + 22	ns
$\overline{RAS}\uparrow$ delay time from CLKOUT \uparrow	(42) tDKRAH		0	22	ns
\overline{RAS} high-level width	(43) tWRAH		(n + 1)T - 15		ns
$\overline{RAS}\uparrow$ delay time from $\overline{WRH}\downarrow, \overline{WRL}\downarrow$	(121) tDWRAH		(N + 0.5)T - 10		ns
Address setup time (to $\overline{RAS}\downarrow$)	(122) tSARAL		nT - 12		ns
READY setup time (to CLKOUT \downarrow)	(44) tSRYHK		18		ns
READY hold time (from CLKOUT \downarrow)	(45) tHKRYL		12		ns
READY setup time (to CLKOUT \downarrow)	(46) tSRYLK		18		ns
READY hold time (from CLKOUT \downarrow)	(47) tHKRYH		12		ns
\overline{RESET} low-level width	(48) tWRSL1	STOP release/power-on reset	30		ms
	(49) tWRSL2	System reset	1000 + 2T		ns
NMI high-level width	(50) tWNIH		5		μs
NMI low-level width	(51) tWNIL		5		μs
INTPm setup time (to CLKOUT \downarrow)	(52) tSIQK	m = 0 to 5	25		ns
INTPm high-level width	(53) tWIQH	m = 0 to 5	10T		ns
INTPm low-level width	(54) tWQIL	m = 0 to 5	10T		ns
\overline{POLL} setup time (to CLKOUT \downarrow)	(55) tSPLK		25		ns
HLDRQ setup time (to CLKOUT \downarrow)	(56) tSHQK		25		ns
$\overline{HLDAK}\downarrow$ delay time from CLKOUT \uparrow	(57) tDKHA		0	27	ns
$\overline{HLDAK}\downarrow$ delay time from bus float	(58) tFCHA		0		ns
Bus output delay time from $\overline{HLDAK}\uparrow$	(59) tDHAC		T - 22.5		ns

n : Number of address wait states
 N : Number of data wait states
 T : t_{cyk}

Remark Numbers in the Symbol column correspond to numbers in the timing charts.

PARAMETER	SYMBOL	TEST CONDITIONS	MIN.	MAX.	UNIT
$\overline{\text{HLDA}}\uparrow$ delay time from $\text{HLDRQ}\downarrow$	(60) t_{DHOHA}		0.5T – 15	3.5T + 35	ns
Bus output delay time from $\text{HLDRQ}\downarrow$	(61) t_{DHQC}		0.5T + 45		ns
HLDRQ low-level width	(62) t_{WHQL}		2T		ns
$\overline{\text{HLDA}}\downarrow$ low-level width	(63) t_{WHAL}		3T – 10		ns
$\overline{\text{BUSLOCK}}\uparrow$ delay time from $\text{CLKOUT}\uparrow$	(64) t_{DKBL}		0	27	ns
DMARQ_m setup time (to $\text{CLKOUT}\downarrow$)	(65) t_{SDQK}	Except demand release mode; $m = 0$ or 1	25		ns
DMARQ_m high-level width	(66) t_{WDQH}	Except demand release mode; $m = 0$ or 1	2T		ns
DMARQ_m low-level width	(67) t_{WDQL}	Except demand release mode; $m = 0$ or 1	2T		ns
DMARQ_m setup time (to $\text{CLKOUT}\uparrow$)	(68) t_{SKDQ}	Demand release mode; $m = 0$ or 1		5	ns
DMARQ_m low-level hold time (from $\text{CLKOUT}\downarrow$)	(69) t_{HKDQ}	Demand release mode; $m = 0$ or 1	12		ns
$\overline{\text{DMAAK}}_m\downarrow$ delay time from $\text{CLKOUT}\uparrow$	(70) t_{DKDA}	$m = 0$ or 1	0	27	ns
$\overline{\text{DMAAK}}_m$ low-level width	(71) t_{WDAL}	$m = 0$ or 1	$(3 + n + N)T - 10$		ns
$\overline{\text{TCE}}_m\downarrow$ delay time from $\text{CLKOUT}\uparrow$	(72) t_{DKTE}	$m = 0$ or 1	0	27	ns
$\overline{\text{TCE}}_m$ low-level width	(73) t_{WTCL}	$m = 0$ or 1	$T - 10$		ns
TOUT high-level width	(74) t_{WTOH}		8T – 10		ns
TOUT low-level width	(75) t_{WTOL}		8T – 10		ns
$\overline{\text{WDTOUT}}$ low-level width	(76) t_{WWTL}		32T – 10		ns
$\overline{\text{SCK}}$ cycle time	(77) t_{CYSK}	Input	8T		ns
		Output	8T – 10		ns
$\overline{\text{SCK}}$ high-level width	(78) t_{WSKH}	Input	4T – 10		ns
		Output	4T – 10		ns
$\overline{\text{SCK}}$ low-level width	(79) t_{WSKL}	Input	4T – 10		ns
		Output	4T – 10		ns
SI, SB setup time (to $\overline{\text{SCK}}\uparrow$)	(80) t_{SSSK}		50		ns
SI, SB hold time (from $\overline{\text{SCK}}\uparrow$)	(81) t_{HSKS}		150		ns
SO, SB delay time from $\overline{\text{SCK}}\downarrow$	(82) t_{DSKSB1}	IOE mode (CMOS push-pull output)	0	90	ns
	(83) t_{DSKSB2}	SBI mode (open-drain output, $R_L = 1 \text{ k}\Omega$)	0	190	ns
SB high-level hold time (from $\overline{\text{SCK}}\uparrow$)	(84) t_{HSKSB}	SBI mode	4T		ns
SB low-level setup time (to $\overline{\text{SCK}}\downarrow$)	(85) t_{SSBSK}		4T		ns
SB high-level width	(86) t_{WSBH}		4T		ns
SB low-level width	(87) t_{WSBL}		4T		ns

n : Number of address wait states
 N : Number of data wait states
 T : t_{CYK}

Remark Numbers in the Symbol column correspond to numbers in the timing charts.

PARAMETER	SYMBOL	TEST CONDITIONS	MIN.	MAX.	UNIT	
$\overline{\text{CTS}}$ high-level width	(88) t_{WCTH}		2T		ns	
$\overline{\text{CTS}}$ low-level width	(89) t_{WCTL}		2T		ns	
Transmit/receive data cycle	(90) t_{CYD}	UART	32T		ns	
TxC output clock cycle	(91) t_{CYC}	UART	32T		ns	
TxC output clock high-level width	(92) t_{WCH}		16T – 10		ns	
TxC output clock low-level width	(93) t_{WCL}		16T – 10		ns	
TxD delay time from TxC↓	(94) t_{DCTD}		0	90	ns	
TxD delay time from $\overline{\text{CTS}}$ ↓	(95) t_{DCTD}			2 t_{CYC}	ns	
$\overline{\text{DATASTB}}$ setup time	(96) t_{SDSK}		Input mode	25		ns
$\overline{\text{DATASTB}}$ low-level width	(97) t_{WDSL1}		Input mode	2T		ns
	(98) t_{WDSL2}	Output mode	2T – 10	512T	ns	
PD setup time (to $\overline{\text{DATASTB}}$ ↓)	(99) t_{SPDSD1}	Input mode ($\overline{\text{DATASTB}}$ ↓ latch mode)	45		ns	
PD hold time (from $\overline{\text{DATASTB}}$ ↓)	(100) t_{HSPD1}		4T		ns	
BUSY delay time from $\overline{\text{DATASTB}}$ ↓	(101) t_{DDSBY1}			4T	ns	
PD setup time (to $\overline{\text{DATASTB}}$ ↑)	(102) t_{SPDSD2}		Input mode ($\overline{\text{DATASTB}}$ ↑ latch mode)	45		ns
PD hold time (from $\overline{\text{DATASTB}}$ ↑)	(103) t_{HSPD2}	4T			ns	
BUSY delay time from $\overline{\text{DATASTB}}$ ↑	(104) t_{DDSBY2}			4T	ns	
$\overline{\text{DATASTB}}$ ↓ delay time from PD	(105) t_{DPDSDL}	Output mode		2T – 30	512T	ns
$\overline{\text{DATASTB}}$ setup time (to $\overline{\text{ACK}}$ ↓)	(106) t_{SDSAK}		0		ns	
$\overline{\text{ACK}}$ input low-level width	(107) t_{WAKL}		2T		ns	
$\overline{\text{DATASTB}}$ setup time (to BUSY↑)	(108) t_{SDSBY}		0		ns	
BUSY input high-level width	(109) t_{WBYH}		2T		ns	
Port output delay time (from CLKOUT↓)	(123) t_{DKP}			8	50	ns
Port input setup time (to CLKOUT↓)	(124) t_{SPK}			25		ns
Port input hold time (from CLKOUT↓)	(125) t_{HKP}		16		ns	
DMARQ _m high-level hold time (from $\overline{\text{ASTB}}$ ↓)	(126) t_{HSTDQ}	Demand release mode; m = 0 or 1	0		ns	
$\overline{\text{REFRQ}}$ ↓ delay time from CLKOUT↑	(127) t_{DKREL}		0	25	ns	
$\overline{\text{REFRQ}}$ ↑ delay time from CLKOUT↑	(128) t_{DKREH}		0	25	ns	
$\overline{\text{RAS}}$ delay time from $\overline{\text{REFRQ}}$ ↓	(129) t_{DRERA}		nT – 5		ns	
$\overline{\text{RD}}$ ↓ delay time from $\overline{\text{ASTB}}$ ↓	(130) t_{DSTLRL}		0.5T – 5		ns	
TI high-level width	(131) t_{WTIH}		4T		ns	
TI low-level width	(132) t_{WTIL}		4T		ns	
TO _m setup time (to CLKOUT↓)	(133) t_{DKT}	m = 00, 01, 20, 21, 30	5	30	ns	

★
★
★

n : Number of address wait states
 N : Number of data wait states
 T : t_{CYC}

Remark Numbers in the Symbol column correspond to numbers in the timing charts.

A/D CONVERTER CHARACTERISTICS (T_A = -40 to +85 °C, V_{DD} = +5.0 V ± 10 %, AV_{SS} = 0 V, V_{DD} - 0.5 V ≤ AV_{DD} ≤ V_{DD})

PARAMETER	SYMBOL	TEST CONDITIONS	MIN.	TYP.	MAX.	UNIT
Resolution			8			Bit
Total error *1		3.4 V ≤ AV _{REF} ≤ AV _{DD}			0.8	%
		4.5 V ≤ AV _{REF} ≤ AV _{DD}			0.6	%
Quantization error					±1/2	LSB
Conversion time	t _{CONV}	80 ns ≤ T ≤ 125 ns (for μPD70433, 70433-12)	160T			ns
		65 ns ≤ T ≤ 125 ns (for μPD70433-16)				
		125 ns ≤ T ≤ 250 ns	120T			ns
Sampling time	t _{SAMP}	80 ns ≤ T ≤ 125 ns (for μPD70433, 70433-12)	32T			ns
		65 ns ≤ T ≤ 125 ns (for μPD70433-16)				
		125 ns ≤ T ≤ 250 ns	24T			ns
Analog input voltage	V _{IAN}		-0.3		AV _{REF} + 0.3	V
Analog input impedance	R _{AN}	Non-sampling		1000		MΩ
		Sampling		*2		
Reference voltage	AV _{REF}		3.4		AV _{DD}	V
AV _{REF} current	AI _{REF}	T = 80 ns		1.5	5.0	mA

T: t_{CYK}

- * 1. Excluding quantization error
- 2. Analog input impedance is identical with the equivalent circuit shown below. (The values in the figure are not guaranteed, but are TYP. values)

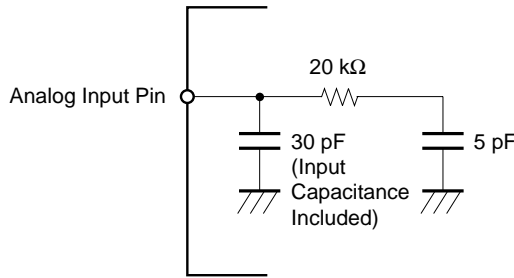

DATA MEMORY STOP MODE LOW SUPPLY VOLTAGE DATA RETENTION CHARACTERISTICS (T_A = -40 to +85 °C)

PARAMETER	SYMBOL	TEST CONDITIONS	MIN.	MAX.	UNIT
Data retention supply voltage	(115) V _{DDDR}		2.5	5.5	V
Supply voltage rise time	(116) t _{rVD}		200		μs
Supply voltage fall time	(117) t _{fVD}		200		μs

Remark Numbers in the Symbol column correspond to number in the timing chart.

AC Test Input Waveform *1

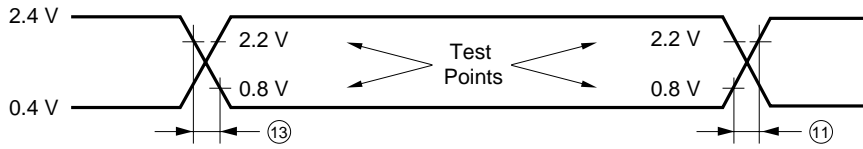

* 1. Except *2

AC Test Input Waveform *2

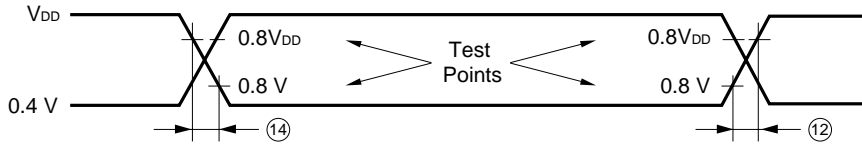

* 2. $\overline{\text{RESET}}$, P10/NMI, X1, P11/INTP0 to P16/INTP5, P30/TxD0/SO0/SB0, P31/RxD0/SB1/SI0, P32/TxC/SCK0, P33/CTS0, P35/RxD1/SI1, P36/SCK1/CTS1

AC Test Output Test Points

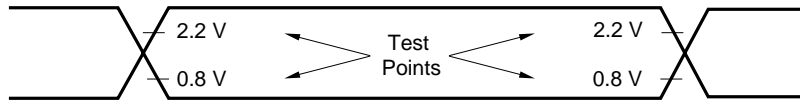

Load Conditions

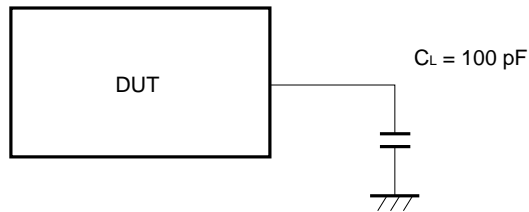

Note If the load capacitance exceeds 100 pF due to the configuration of the circuit, the load capacitance of this device should be reduced to 100 pF or less by insertion of a buffer, etc.

Remark DUT: Measured device

★ Clock Input/Output Timing

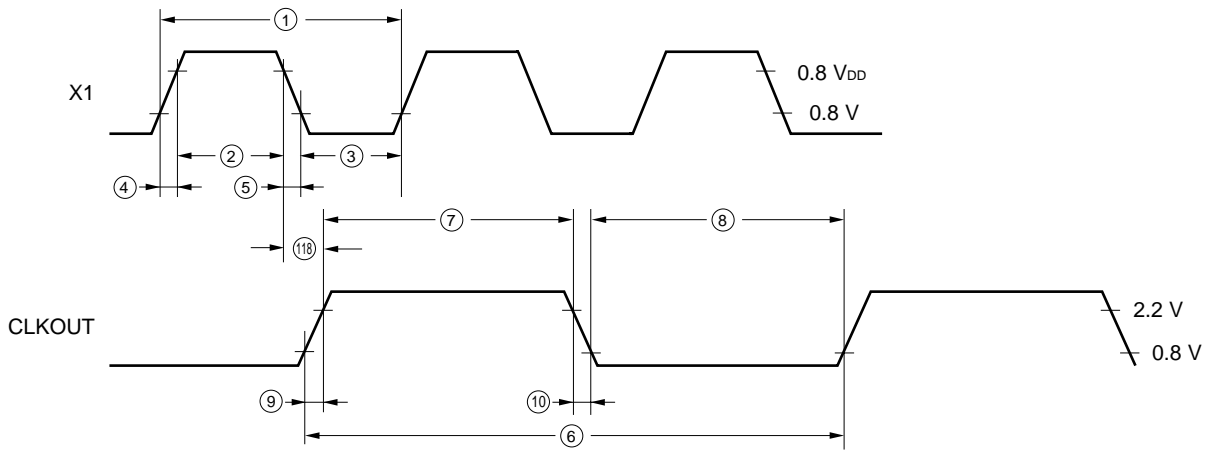

Output Waveform (Except CLKOUT)

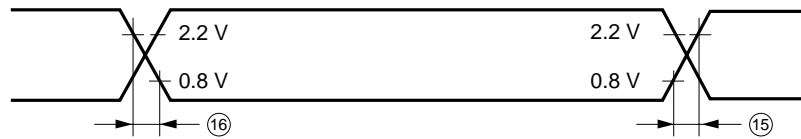

Read Timing

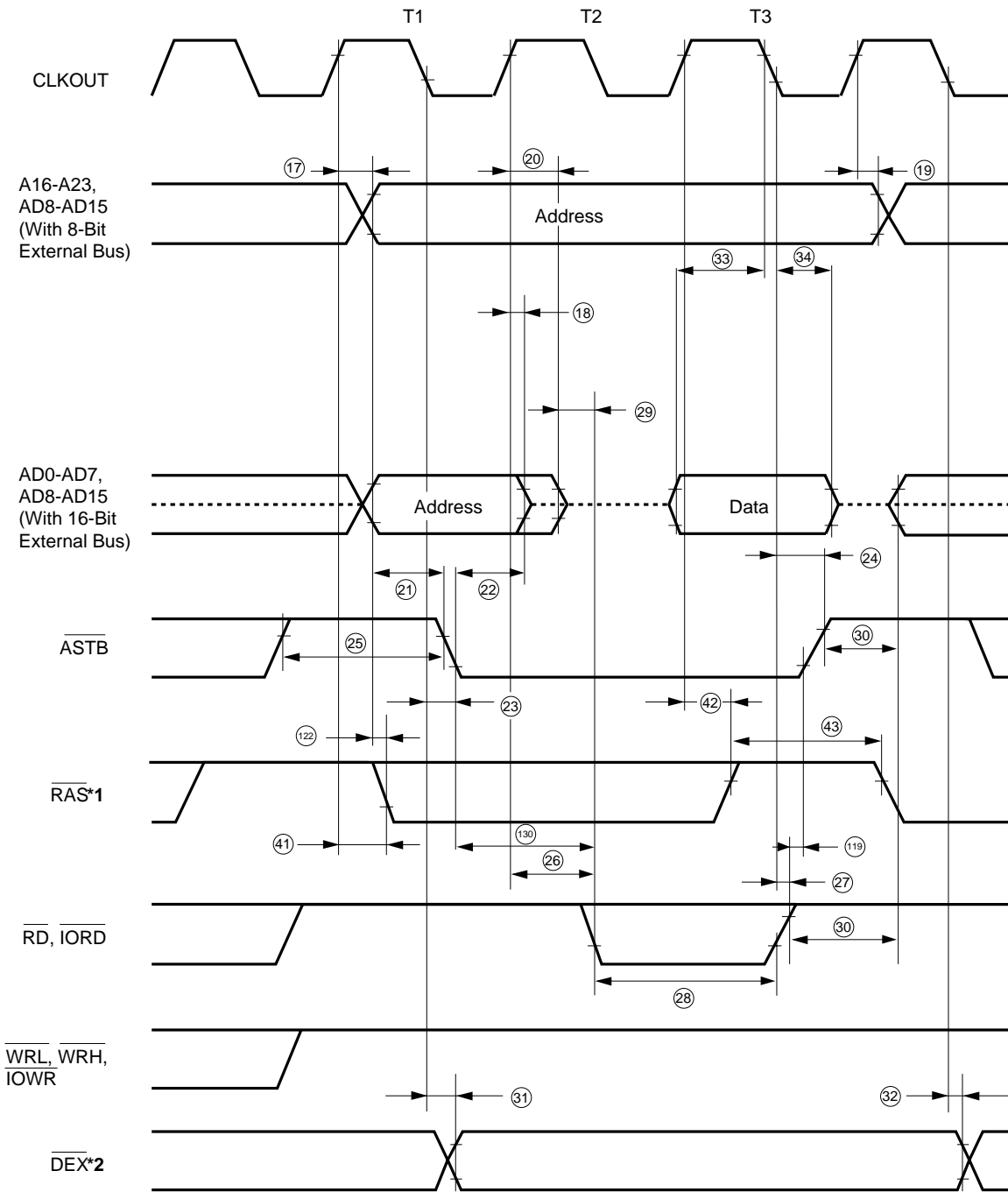

- * 1. Only activated when memory block 1 or 4 (set by the MBS register) is accessed.
- 2. Only valid when the external bus width is 16 bits.

Remark The dotted line indicates high-impedance.

Write Timing

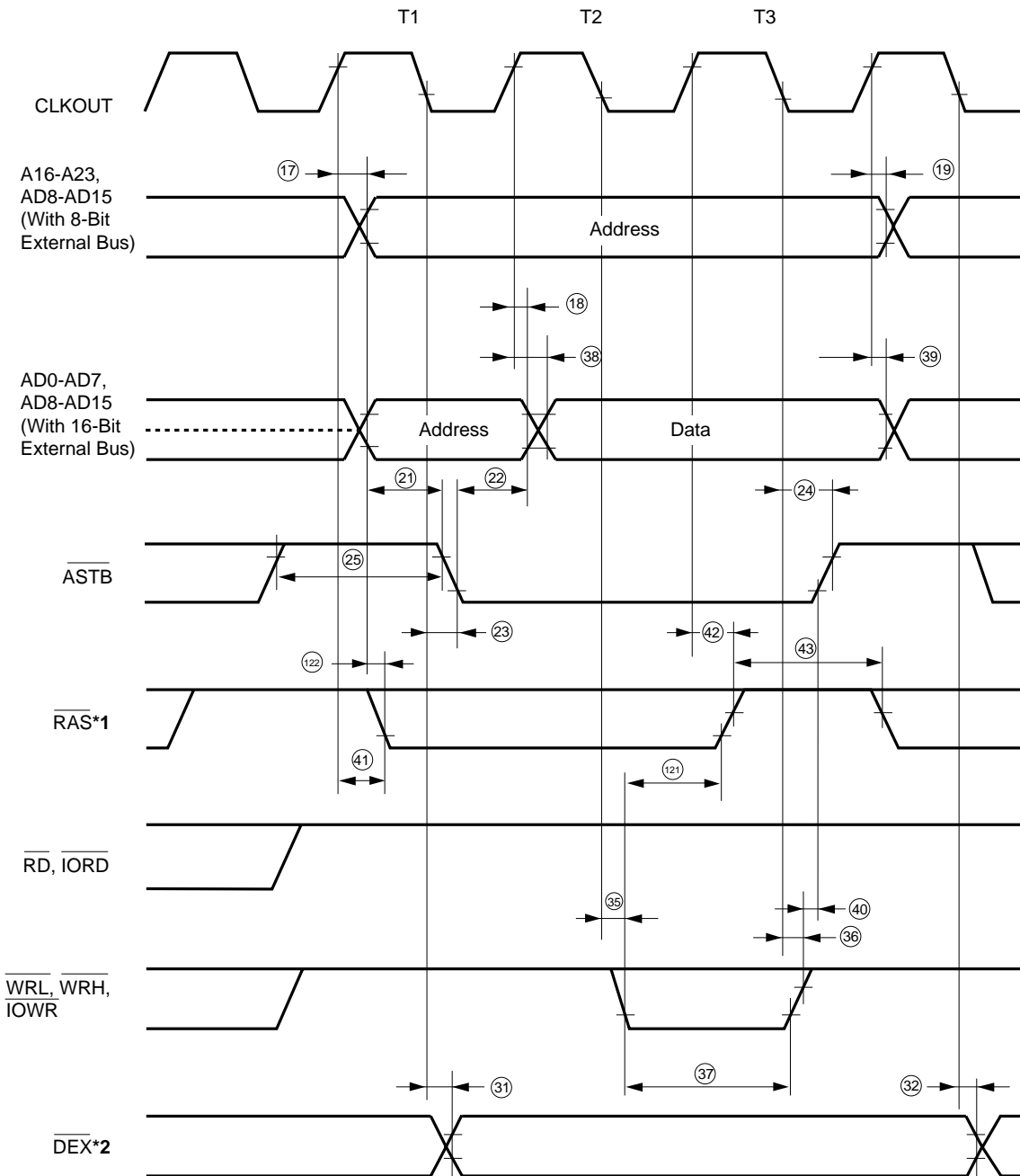

- * 1. Only activated when memory block 1 or 4 (set by the MBC register) is accessed.
- 2. Only valid when the external bus width is 16 bits.

Remark The dotted line indicates high-impedance.

Refresh Timing

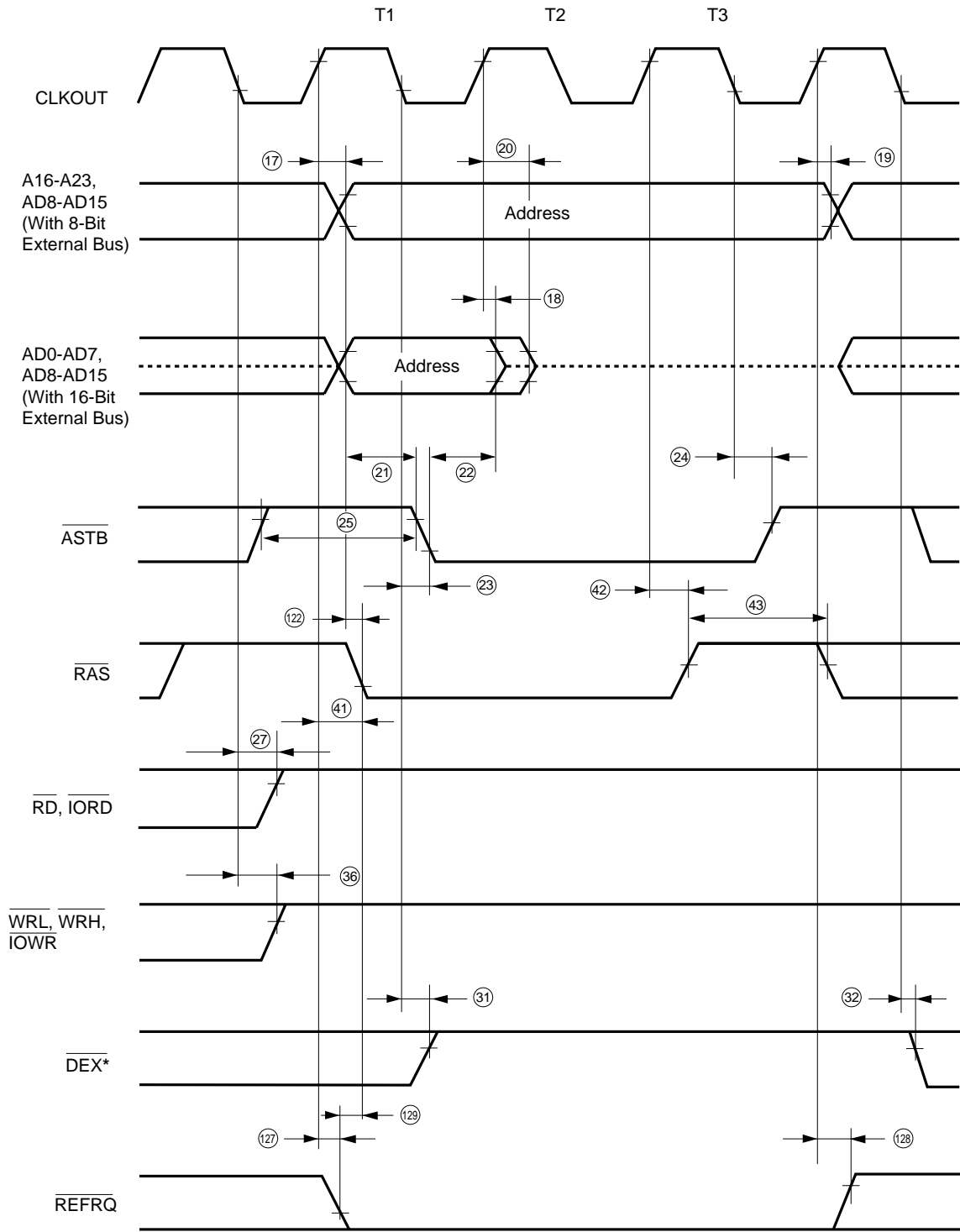

* Only valid when the external bus width is 16 bits.

Remark The dotted line indicates high-impedance.

Ready Input Timing

(1) 1 data wait inserted

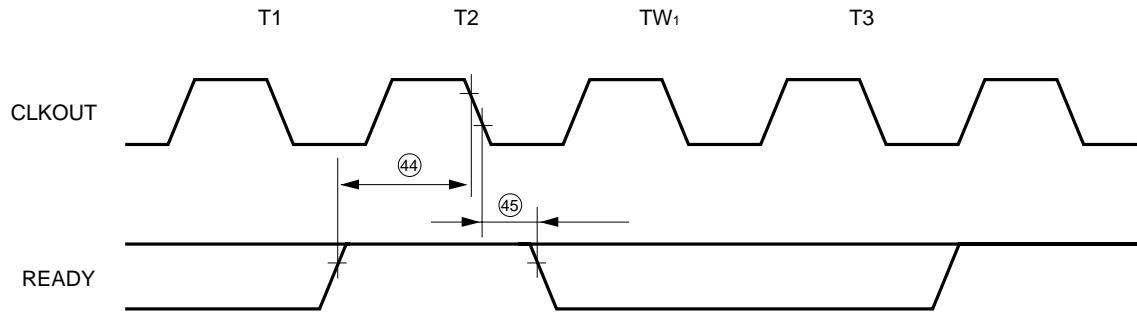

(2) 2 data waits inserted

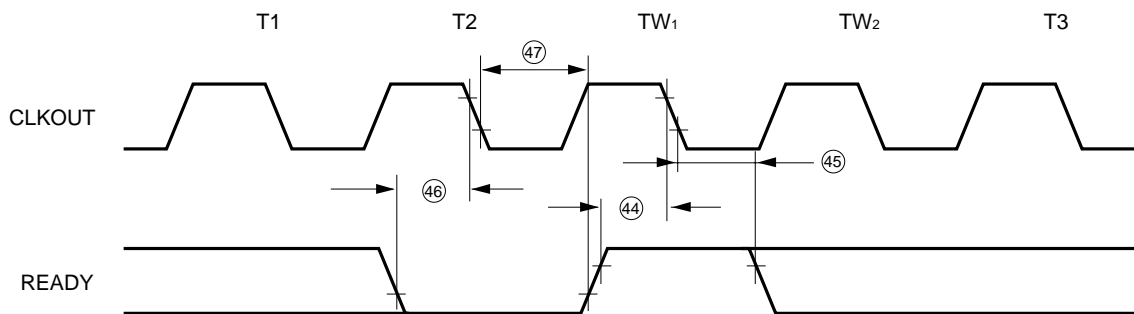

(3) n data waits inserted (n ≥ 3)

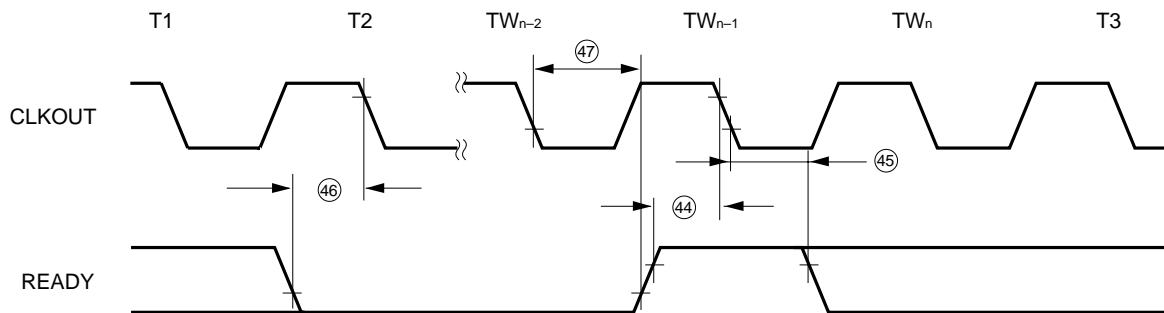

Remark The READY input becomes valid when the corresponding field of the PWCn register (n = 0 or 1) is other than "00" (binary).

DMA Timing (External Memory → External I/O)

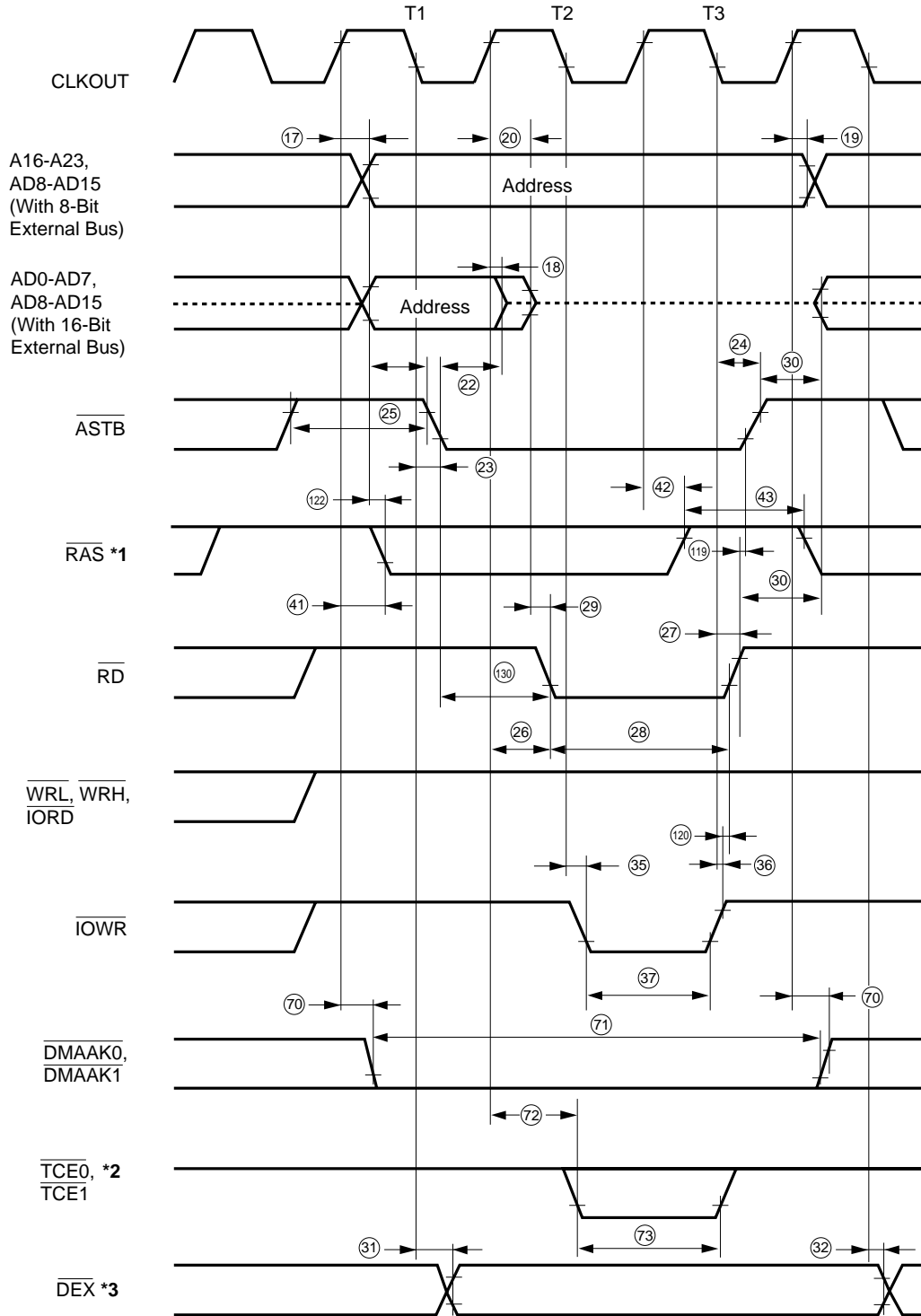

- * 1. Only activated when a DMA transfer is performed on memory block 1 or 4 (set by the MBC register).
- 2. The bus is activated at the last transfer in intelligent DMA mode-2, 2-channel operating mode (stop in termination), or memory-to-memory transfer mode (stop in termination).
- 3. Only valid when the external bus width is 16 bits.

Remark The dotted line indicates high-impedance.

DMA Timing (External I/O → External Memory)

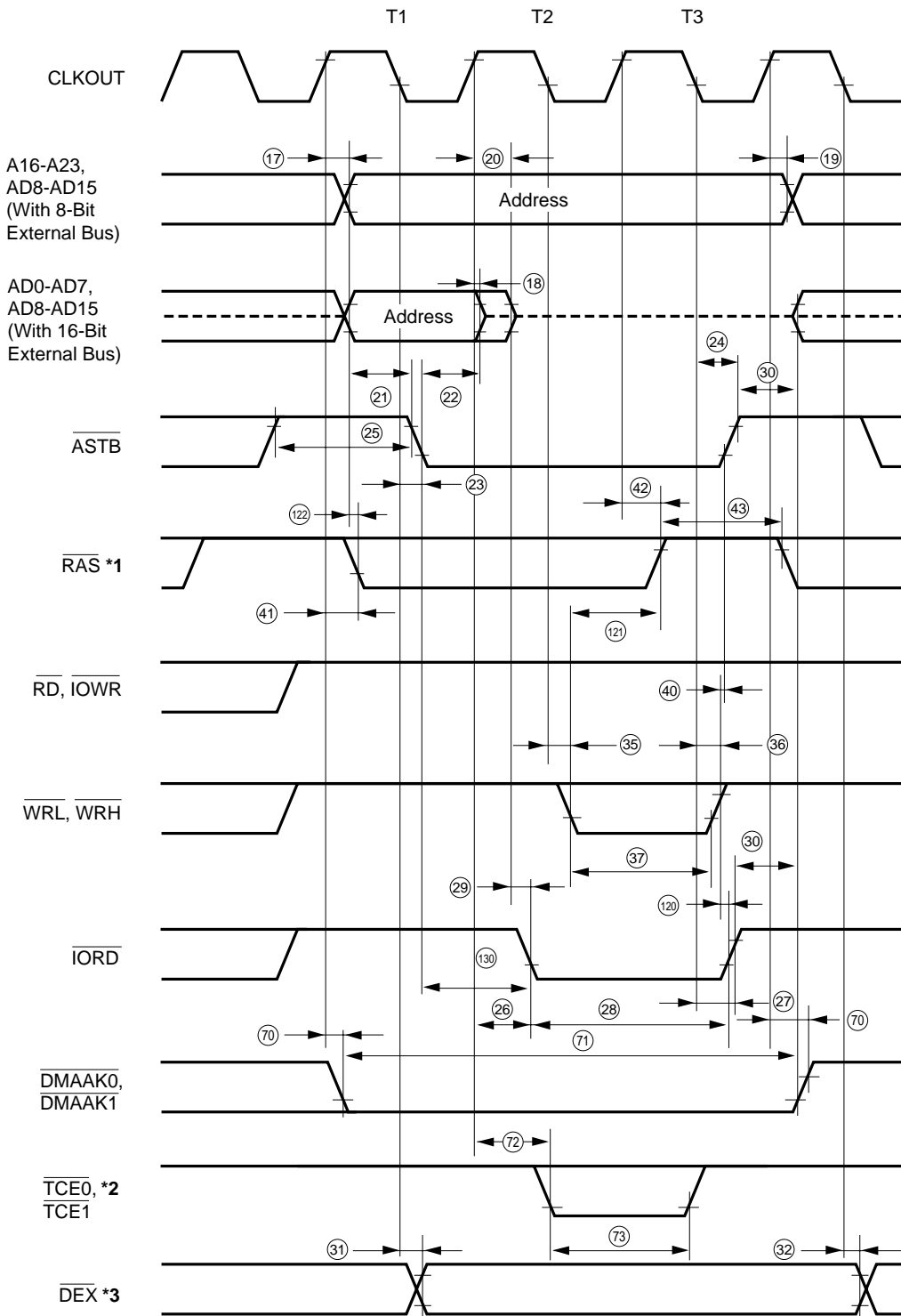

- * 1. Only activated when a DMA transfer is performed on memory block 1 or 4 (set by the MBC register).
- 2. The bus is activated at the last transfer in intelligent DMA mode-2, 2-channel operating mode (stop in termination), or memory-to-memory transfer mode (stop in termination).
- 3. Only valid when the external bus width is 16 bits.

Remark The dotted line indicates high-impedance.

INRPm Input Timing (m = 0 to 5)

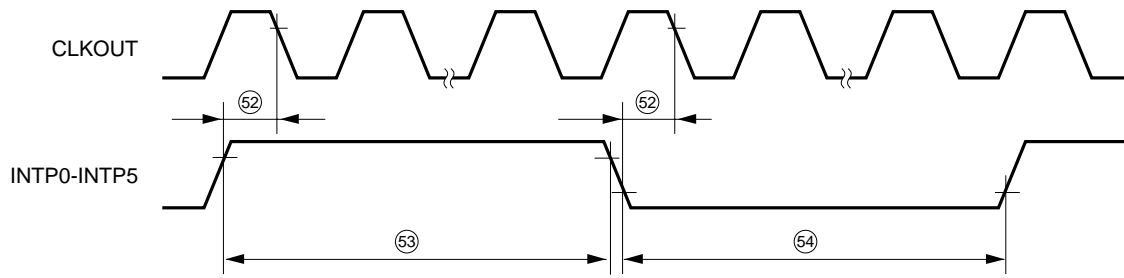

NMI Input Timing

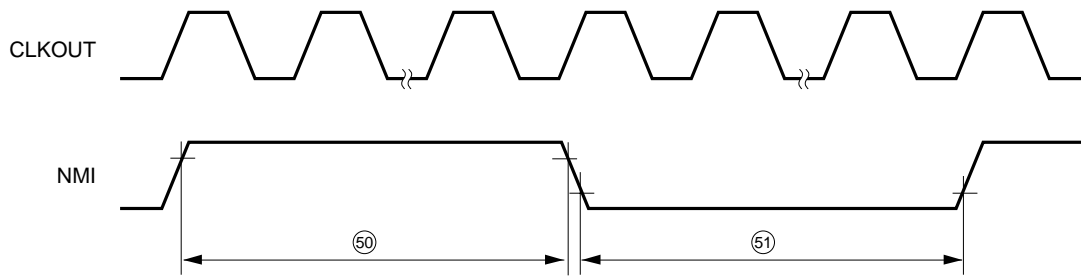

POLL Input Timing

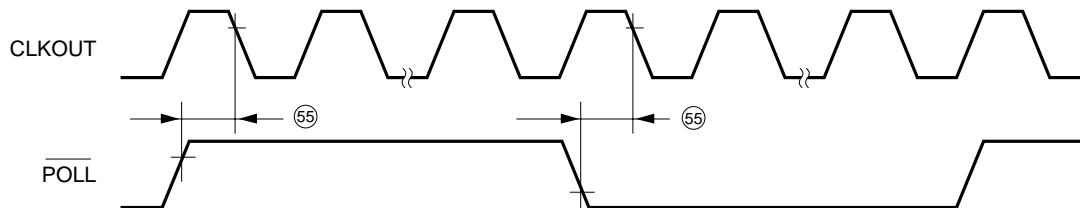

DMARQm Input Timing (m = 0 or 1)

(1) In demand release mode (I/O-to-memory transfer)

(a) Address wait not inserted

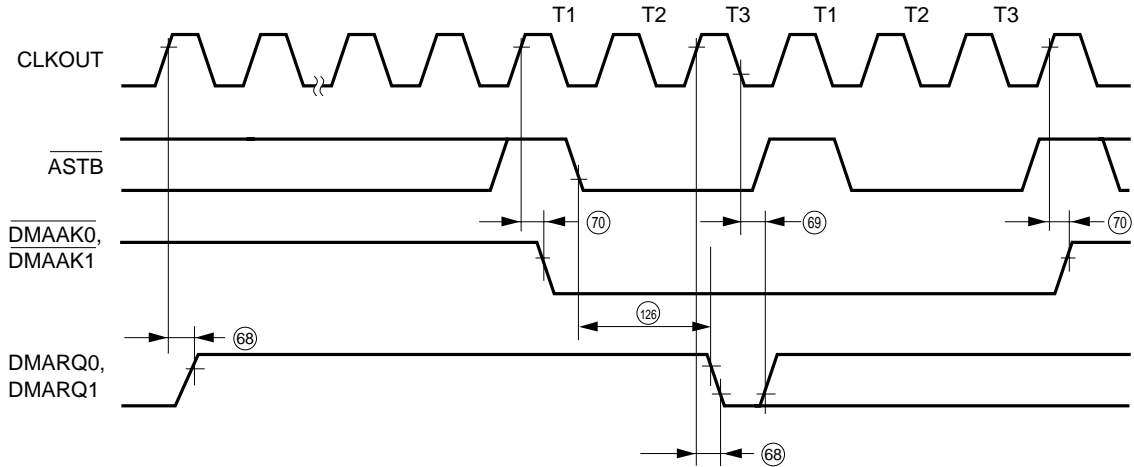

(b) Address wait inserted

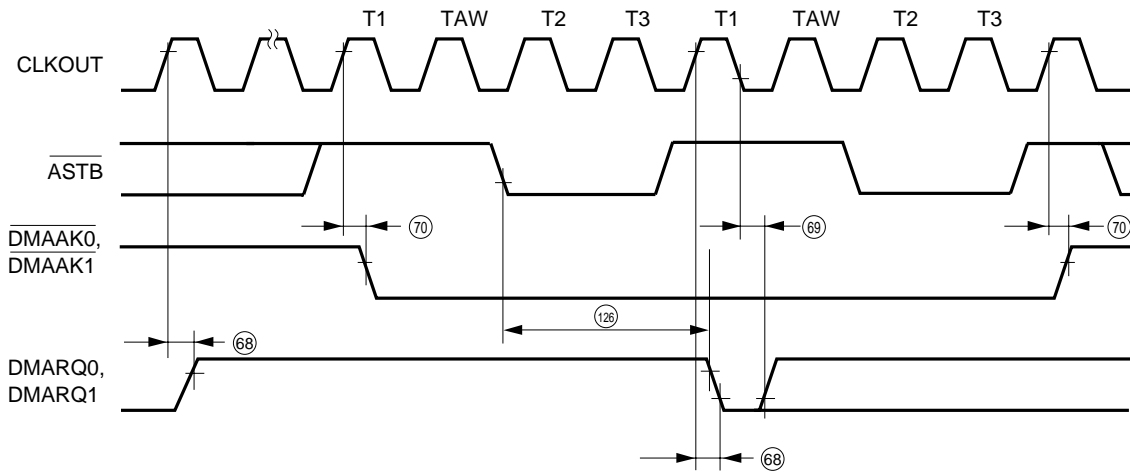

(2) In the mode other than demand release mode

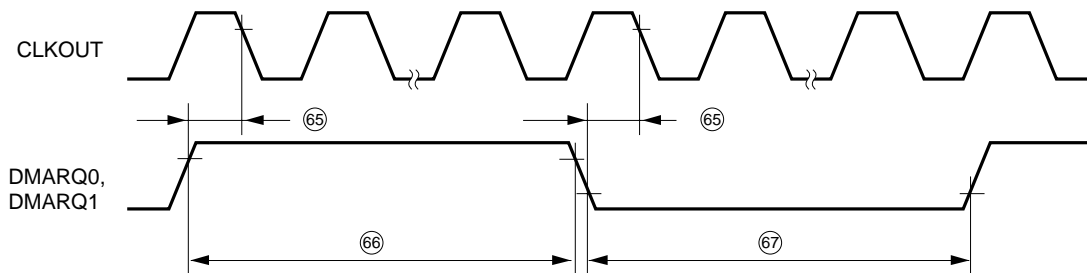

Timer Output Timing

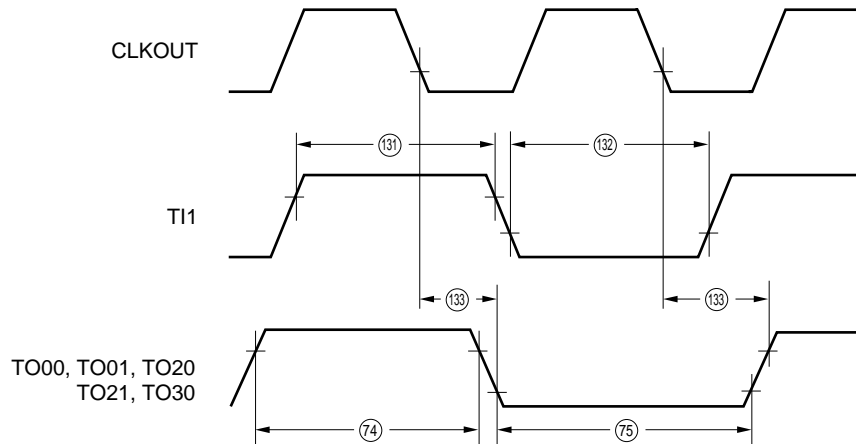

WDTOUT Output Timing

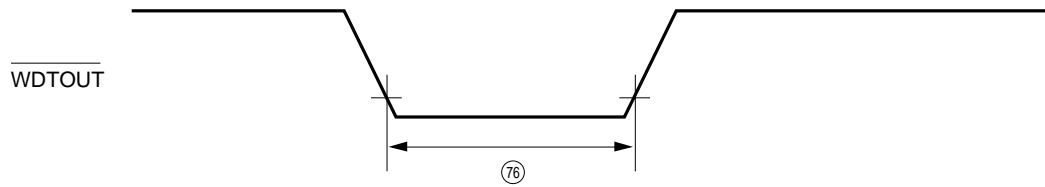

BUSLOCK Output Timing

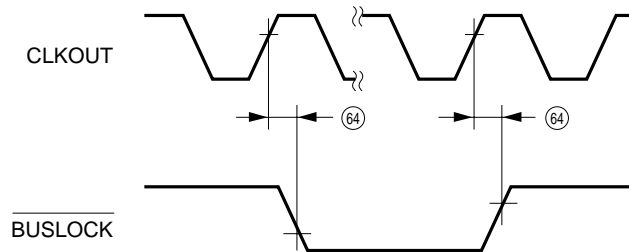

Data Retention Timing (STOP Mode)

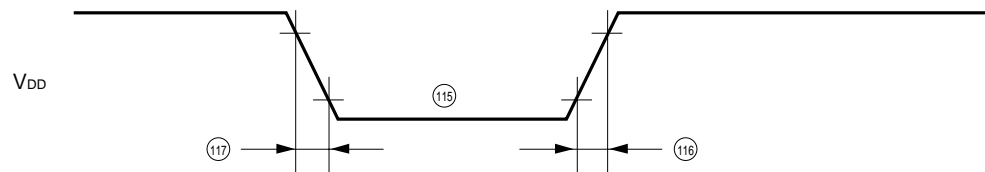

Hold Request/Acknowledge Timing

(1) In normal mode

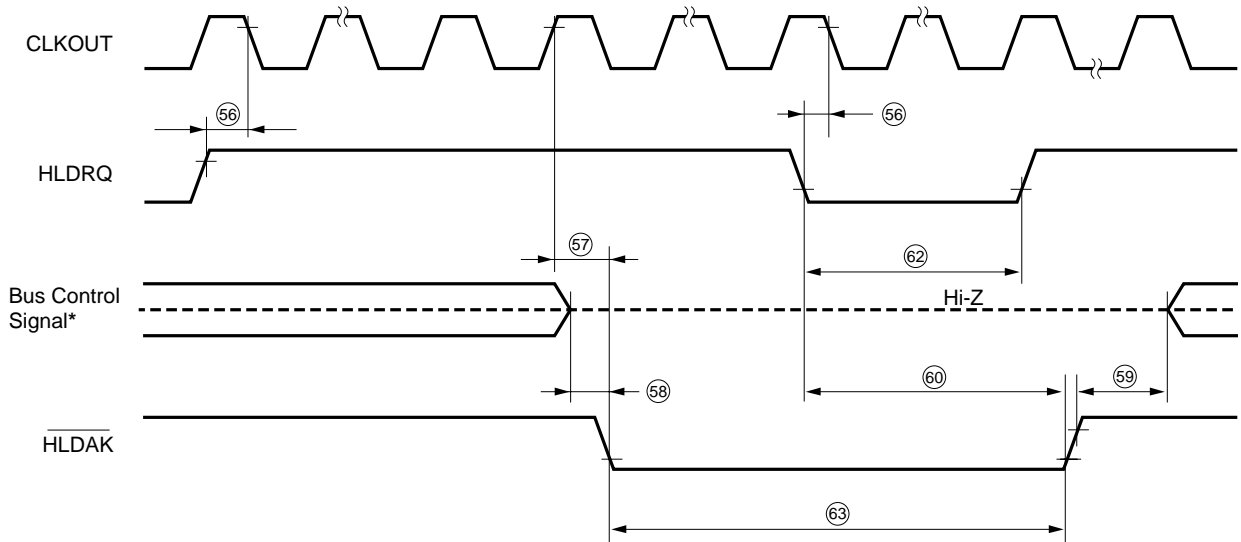

* $\overline{\text{ASTB}}$, $\overline{\text{RD}}$, $\overline{\text{WRH}}$, $\overline{\text{WRL}}$, $\overline{\text{DEX}}$, $\overline{\text{RAS}}$, $\overline{\text{BUSLOCK}}$, $\overline{\text{IORD}}$, $\overline{\text{IOWR}}$, AD0 to AD15, A16 to A23

(2) Release of hold mode for refresh cycle insertion

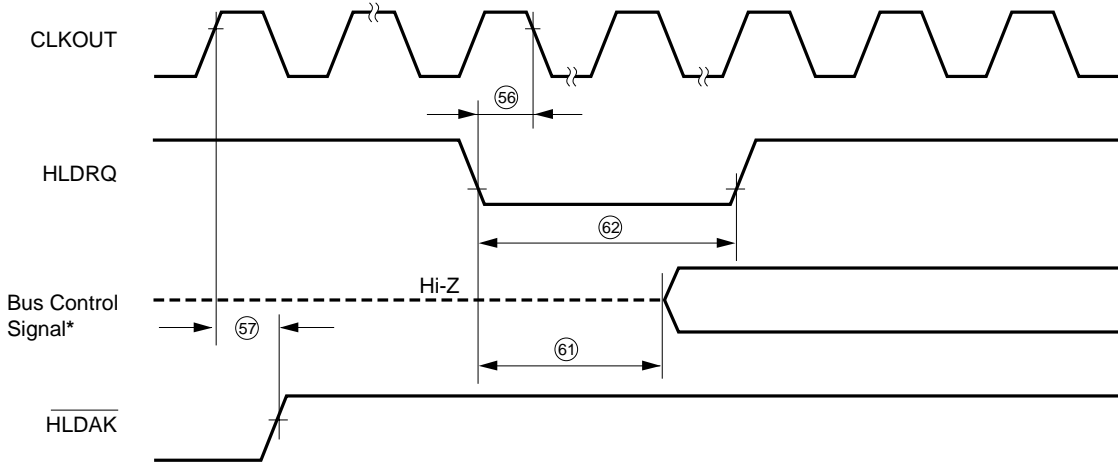

* $\overline{\text{ASTB}}$, $\overline{\text{RD}}$, $\overline{\text{WRH}}$, $\overline{\text{WRL}}$, $\overline{\text{DEX}}$, $\overline{\text{RAS}}$, $\overline{\text{BUSLOCK}}$, $\overline{\text{IORD}}$, $\overline{\text{IOWR}}$, AD0 to AD15, A16 to A23

RESET Input Timing

(1) STOP mode release/power-on reset

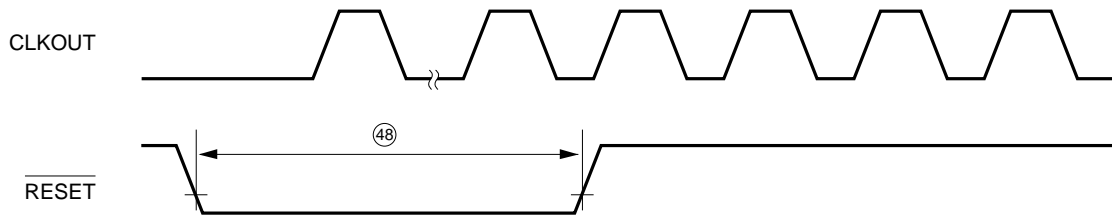

(2) System reset

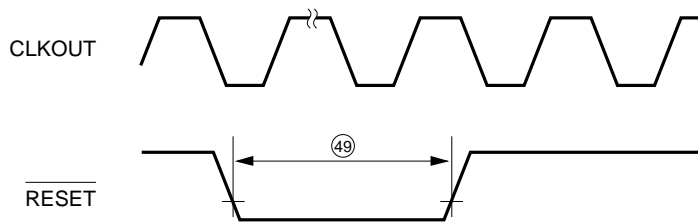

CTS_m Input Timing (m = 0 or 1)

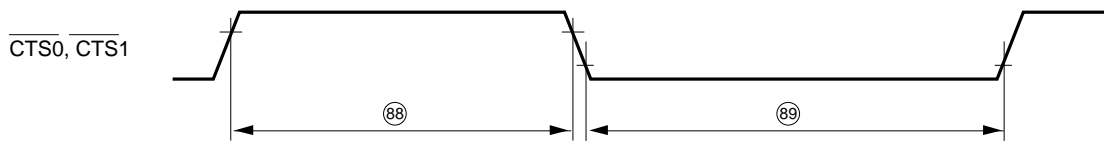

Serial Interface Timing

(1) 3-wire serial I/O mode

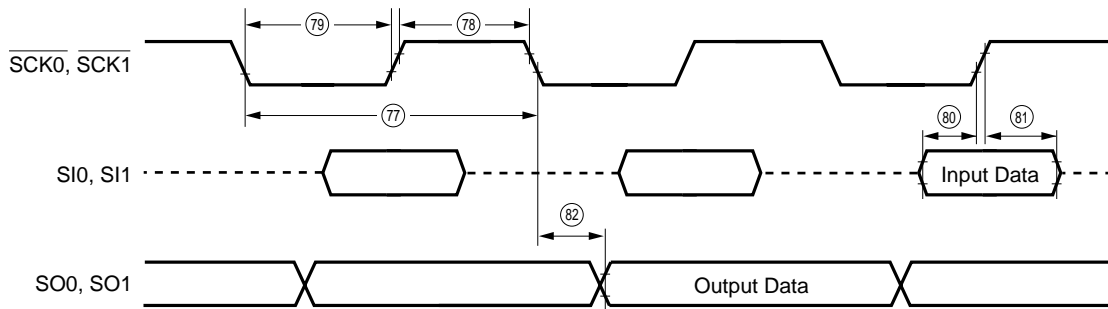

(2) SBI mode

Bus release signal transfer timing

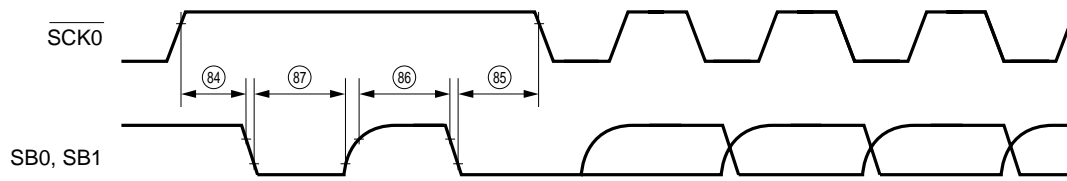

Command signal transfer timing

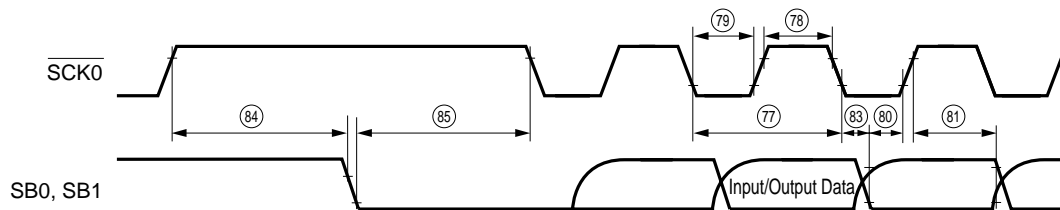

(3) UART mode

Transmit timing

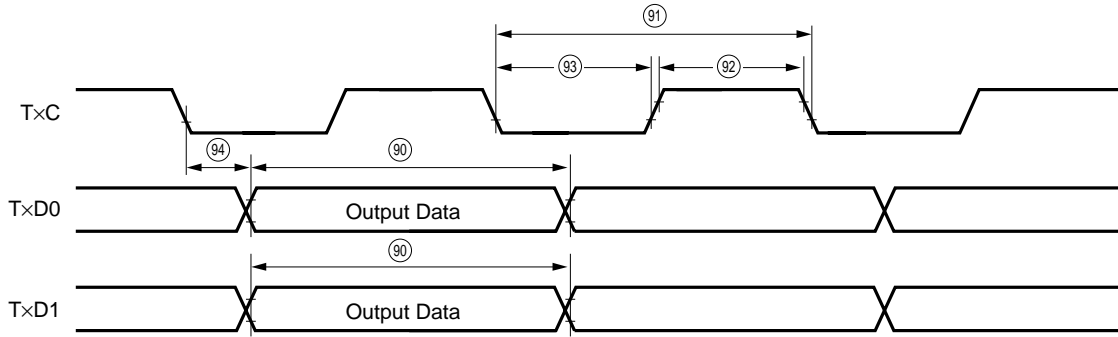

Receive timing

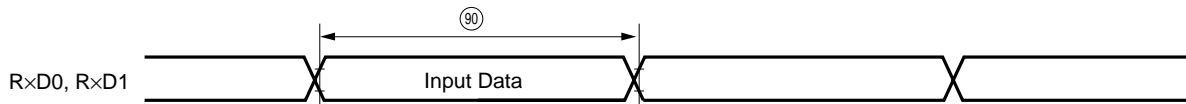

Transmission enable timing

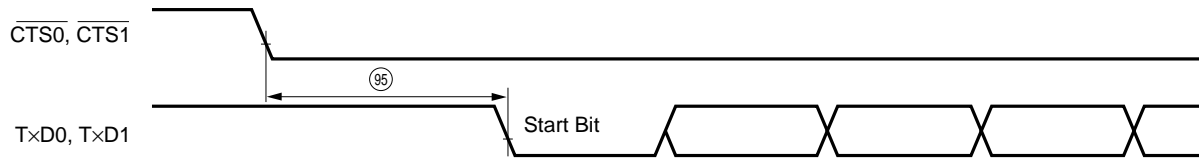

Parallel Interface Timing

(1) Input mode

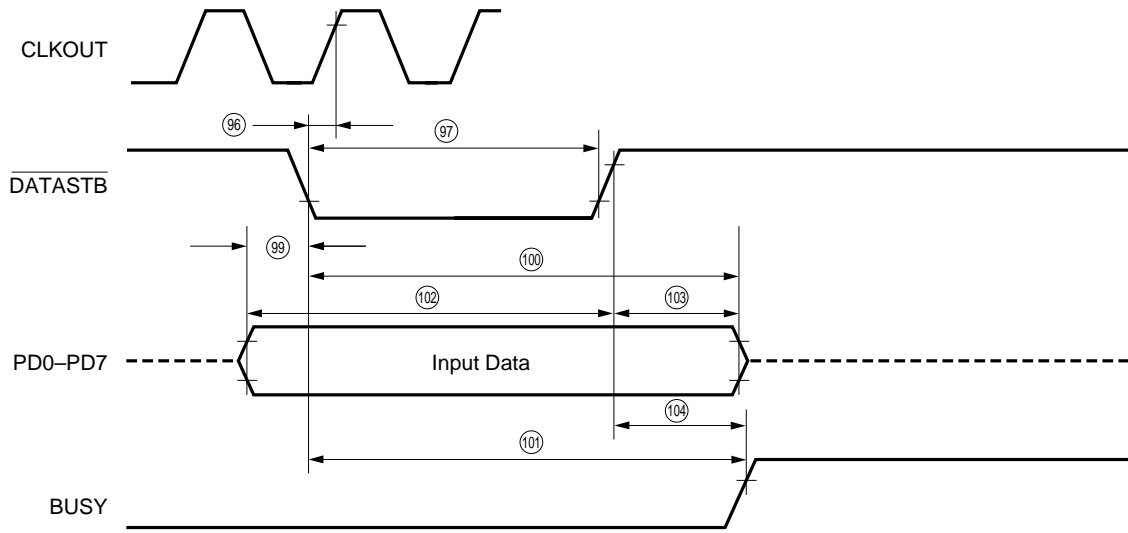

(2) Output mode

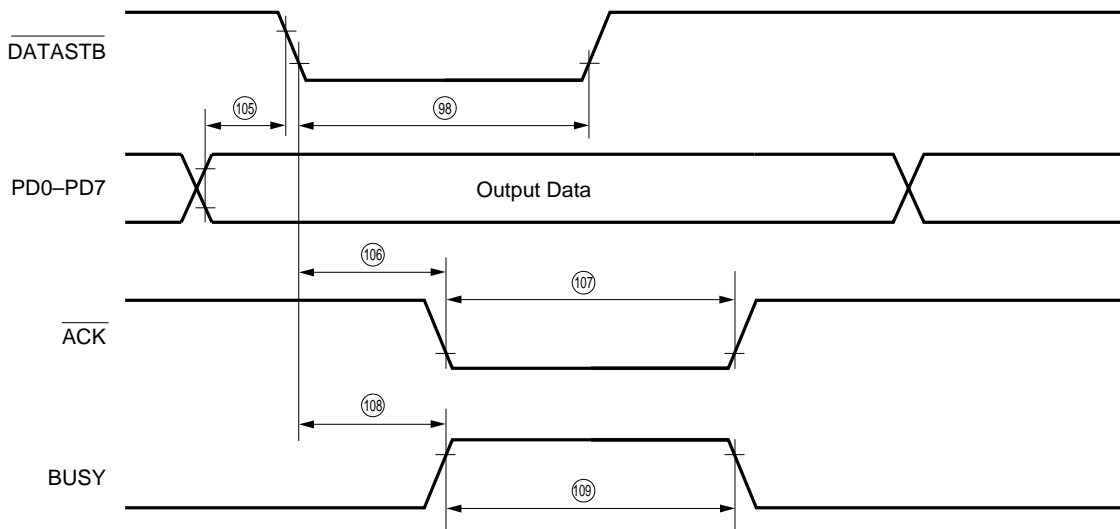

Port Input/Output Timing

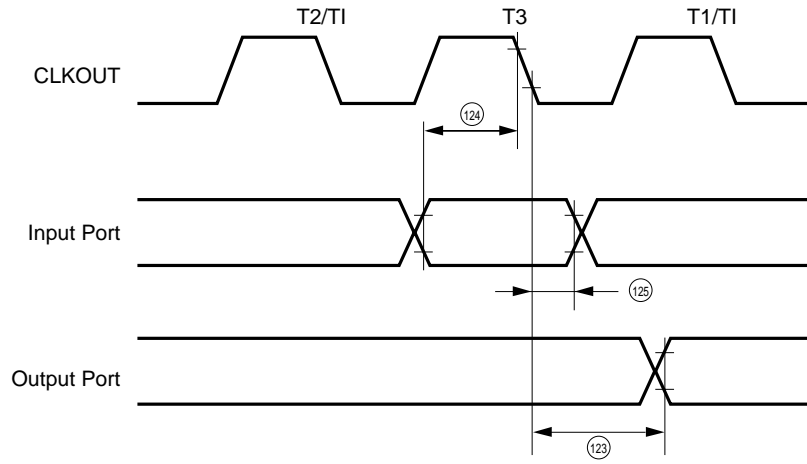

19. CHARACTERISTIC CURVES (FOR REFERENCE ONLY)

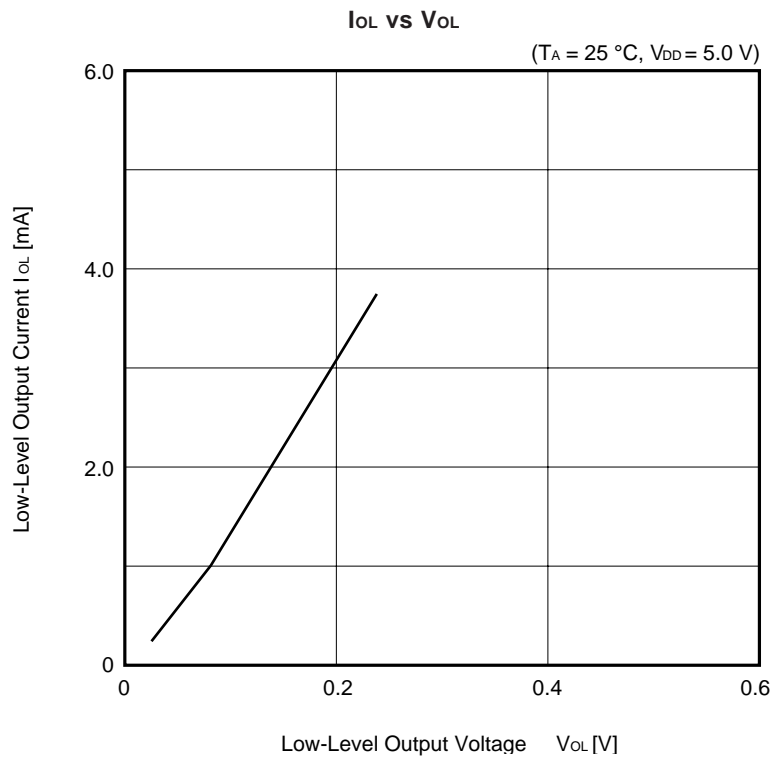
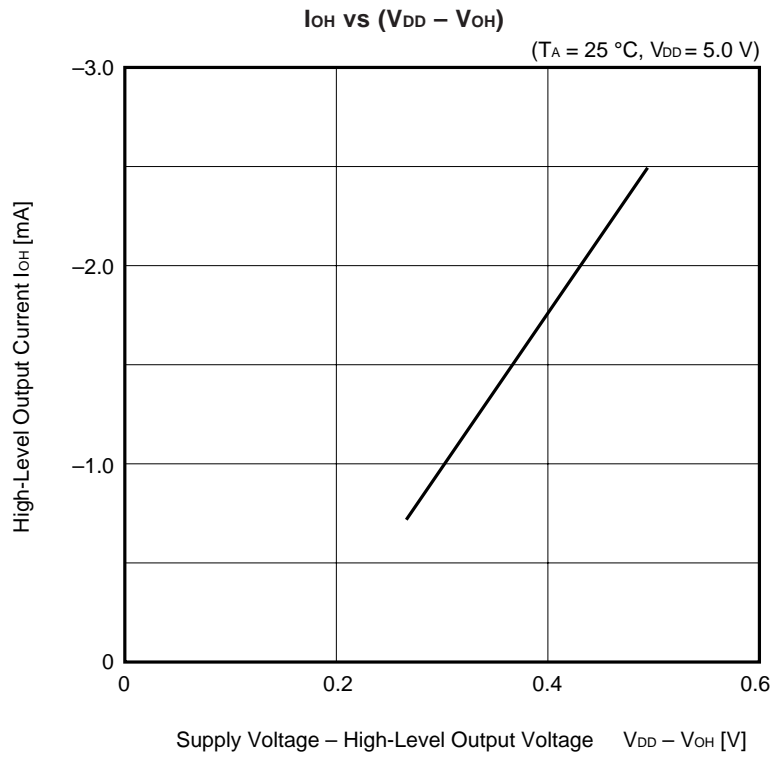

20. PACKAGE DRAWINGS

120 PIN PLASTIC QFP (□28)

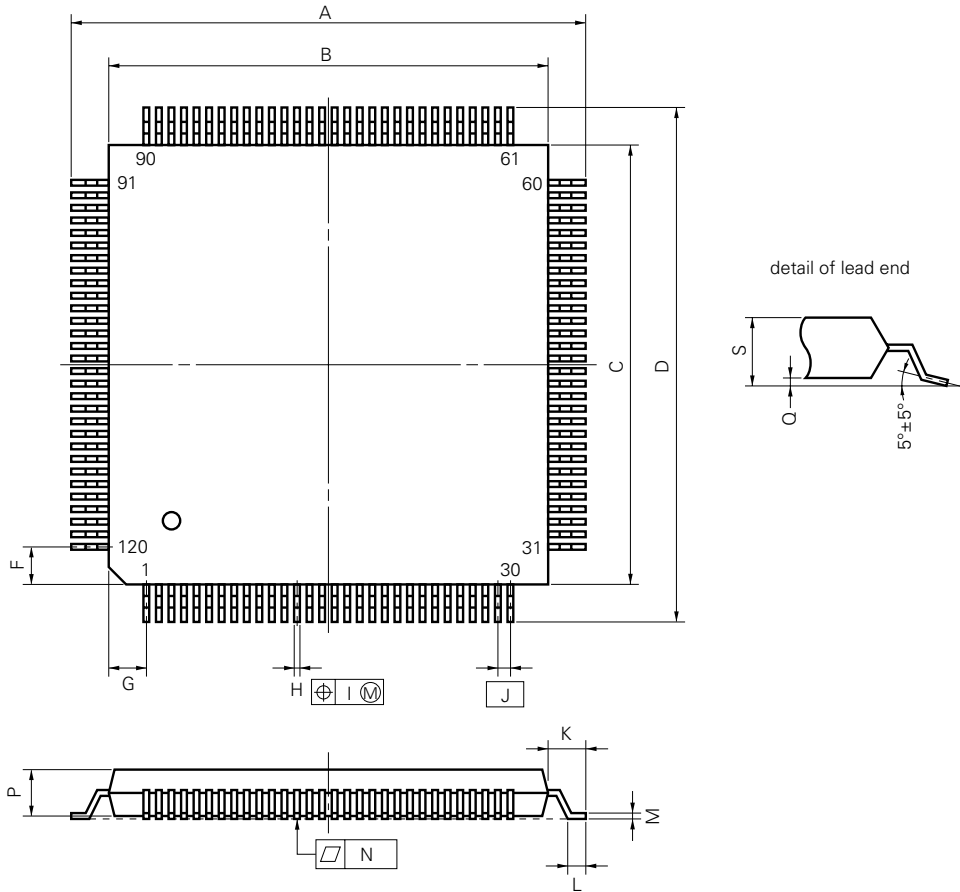

NOTE

Each lead centerline is located within 0.15 mm (0.006 inch) of its true position (T.P.) at maximum material condition.

P120GD-80-5BB-3

ITEM	MILLIMETERS	INCHES
A	32.0±0.4	1.260±0.016
B	28.0±0.2	1.102 ^{+0.009} _{-0.008}
C	28.0±0.2	1.102 ^{+0.009} _{-0.008}
D	32.0±0.4	1.260±0.016
F	2.4	0.094
G	2.4	0.094
H	0.35±0.10	0.014 ^{+0.004} _{-0.005}
I	0.15	0.006
J	0.8 (T.P.)	0.031 (T.P.)
K	2.0±0.2	0.079 ^{+0.009} _{-0.008}
L	0.8±0.2	0.031 ^{+0.003} _{-0.008}
M	0.15 ^{+0.10} _{-0.05}	0.006 ^{+0.004} _{-0.003}
N	0.10	0.004
P	3.7	0.146
Q	0.1±0.1	0.004±0.004
S	4.0 MAX.	0.157 MAX.

120 PIN PLASTIC QFP (FINE PITCH) (□ 20)

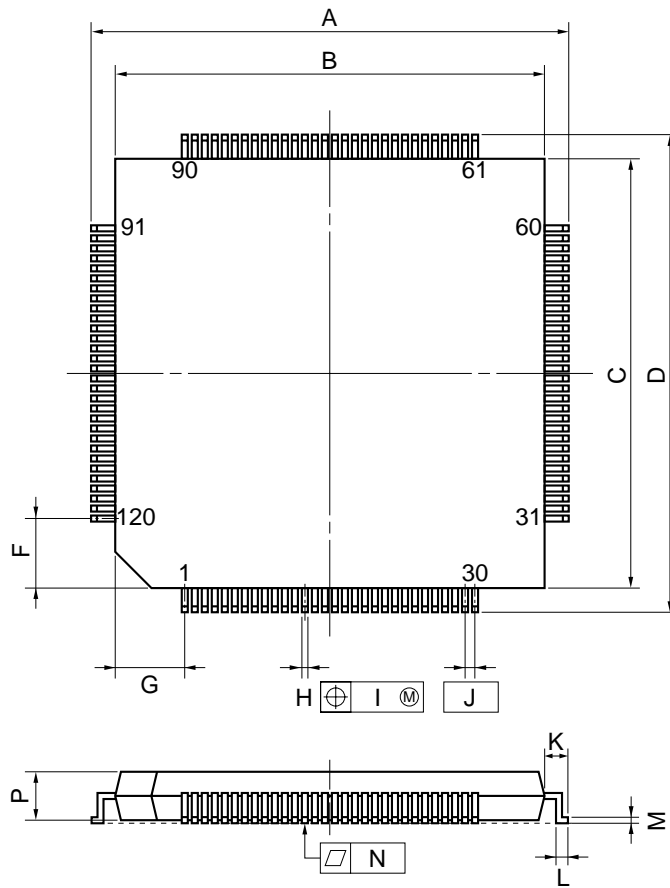

detail of lead end

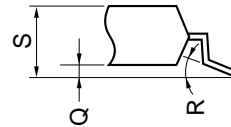

NOTE

Each lead centerline is located within 0.10 mm (0.004 inch) of its true position (T.P.) at maximum material condition.

ITEM	MILLIMETERS	INCHES
A	22.0±0.2	0.866±0.008
B	20.0±0.2	0.787 ^{+0.009} _{-0.008}
C	20.0±0.2	0.787 ^{+0.009} _{-0.008}
D	22.0±0.2	0.866±0.008
F	2.75	0.108
G	2.75	0.108
H	0.22 ^{+0.05} _{-0.04}	0.009±0.002
I	0.10	0.004
J	0.5 (T.P.)	0.020 (T.P.)
K	1.0±0.2	0.039 ^{+0.009} _{-0.008}
L	0.5±0.2	0.020 ^{+0.008} _{-0.009}
M	0.17 ^{+0.03} _{-0.07}	0.007 ^{+0.001} _{-0.003}
N	0.10	0.004
P	2.7	0.106
Q	0.125±0.075	0.005±0.003
R	5°±5°	5°±5°
S	3.0 MAX.	0.119 MAX.

S120GJ-50-3EB-2

132 PIN CERAMIC PGA

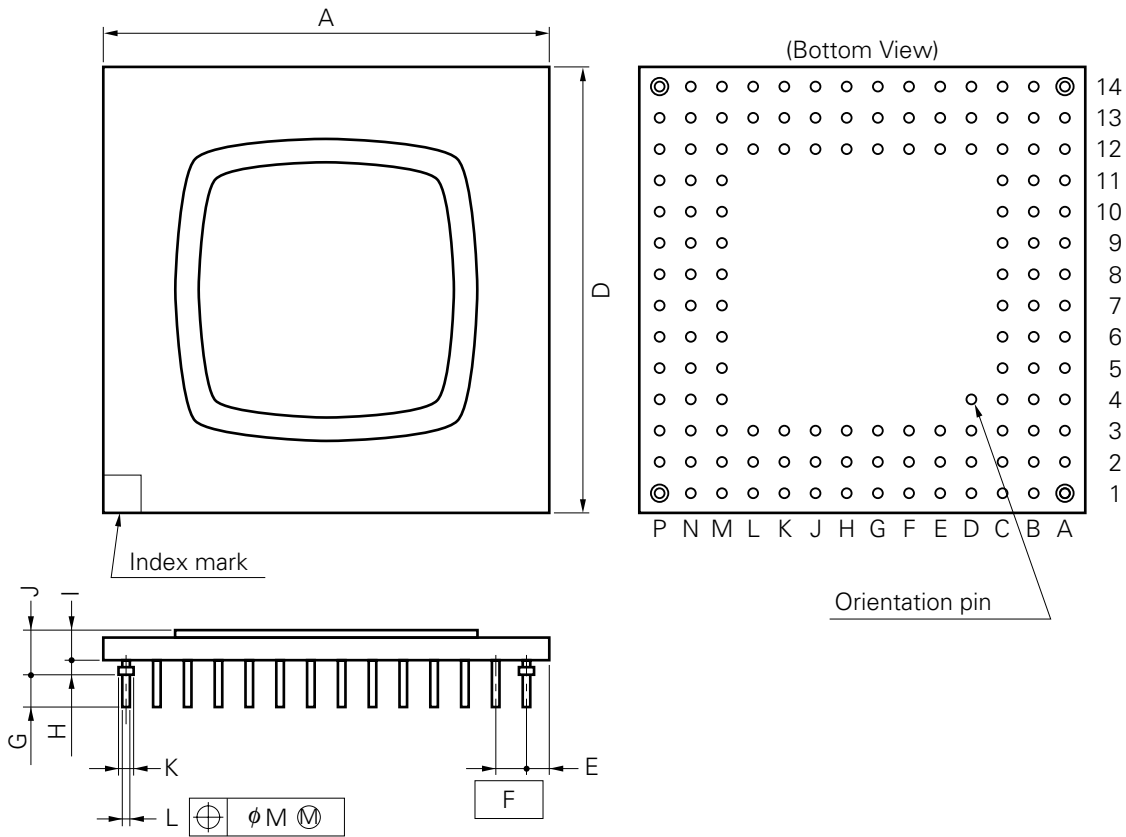

NOTE

Each lead centerline is located within $\phi 0.5$ mm ($\phi 0.020$ inch) of its true position (T.P.) at maximum material condition.

X132R-100A-1

ITEM	MILLIMETERS	INCHES
A	35.56±0.3	1.400±0.012
D	35.56±0.3	1.400±0.012
E	1.27	0.050
F	2.54 (T.P.)	0.100 (T.P.)
G	2.8±0.3	0.110±0.012
H	0.9 MIN.	0.035 MIN.
I	2.95	0.116
J	4.57 MAX.	0.180 MAX.
K	$\phi 1.2 \pm 0.2$	$\phi 0.047^{+0.009}_{-0.008}$
L	$\phi 0.46 \pm 0.05$	$\phi 0.018 \pm 0.002$
M	0.254	0.010

21. RECOMMENDED SOLDERING CONDITIONS

This product should be soldered and mounted under the conditions recommended in the table below.

For details of recommended soldering conditions, refer to the information document “**Semiconductor Device Mounting Technology Manual**” (C10535E).

For soldering methods and conditions other than those recommended, contact our sales personnel.

Table 21-1. Surface Mount Type Soldering Conditions

★ (1) μPD70433GD-xx-5BB : 120-Pin Plastic QFP (28 × 28 mm)

Soldering Method	Soldering Conditions	Recommended Condition Symbol
Infrared reflow	Package peak temperature: 235 °C, Duration: 30 sec. max. (at 210 °C or above), Number of times: Within twice, Time limit: 7 days* (thereafter 36 hours 125 °C prebanking required)	IR35-367-2
VPS	Package peak temperature: 215 °C, Duration: 40 sec. max. (at 200 °C or above), Number of times: Within twice, Time limit: 7 days* (thereafter 36 hours 125 °C prebanking required)	VP15-367-2
Wave soldering	Solder bath temperature: 260 °C or less, Time: 10 sec. max., Number of times: Once, Time limit: 7 days* (thereafter 35 hours 125 °C prebanking required), Preheating temperature: 120 °C max. (Package surface temperature)	WS60-367-1
Partial heating	Pin temperature: 300 °C or below, Duration: 3 sec. max. (per pin row)	—

* For the storage period after dry-pack decompression, storage conditions are max. 25 °C, 65 % RH.

Note Use of more than one soldering method should be avoided (except in the case of partial heating method).

★ (2) μPD70433GJ-xx-3EB : 120-Pin Plastic QFP (Fine Pitch) (20 × 20 mm)

Soldering Method	Soldering Conditions	Recommended Condition Symbol
Infrared reflow	Package peak temperature: 235 °C, Duration: 30 sec. max. (at 210 °C or above), Number of times: Within twice	IR35-00-2
VPS	Package peak temperature: 215 °C, Duration: 40 sec. max. (at 200 °C or above), Number of times: Within twice	VP15-00-2
Partial heating	Pin temperature: 300 °C or below, Duration: 3 sec. max. (per pin row)	—

Note Use of more than one soldering method should be avoided (except in the case of partial heating method).

Table 21-2. Insertion Type Soldering Conditions

μPD70433R-xx : 132-Pin Ceramic PGA

Soldering Method	Soldering Conditions
Wave soldering (lead part only)	Solder temperature: 260 °C or less, Duration: 10 sec. max.
Partial heating	Pin temperature: 300 °C or less, Duration: 3 sec. max. (per pin row)

Note Wave soldering is used on the lead part only, and care must be taken to prevent solder from coming into direct contact with the body.

Regional Information

Some information contained in this document may vary from country to country. Before using any NEC product in your application, please contact the NEC office in your country to obtain a list of authorized representatives and distributors. They will verify:

- Device availability
- Ordering information
- Product release schedule
- Availability of related technical literature
- Development environment specifications (for example, specifications for third-party tools and components, host computers, power plugs, AC supply voltages, and so forth)
- Network requirements

In addition, trademarks, registered trademarks, export restrictions, and other legal issues may also vary from country to country.

NEC Electronics Inc. (U.S.)

Santa Clara, California
Tel: 800-366-9782
Fax: 800-729-9288

NEC Electronics (Germany) GmbH

Duesseldorf, Germany
Tel: 0211-65 03 02
Fax: 0211-65 03 490

NEC Electronics (UK) Ltd.

Milton Keynes, UK
Tel: 01908-691-133
Fax: 01908-670-290

NEC Electronics Italiana s.r.l.

Milano, Italy
Tel: 02-66 75 41
Fax: 02-66 75 42 99

NEC Electronics (Germany) GmbH

Benelux Office
Eindhoven, The Netherlands
Tel: 040-2445845
Fax: 040-2444580

NEC Electronics (France) S.A.

Velizy-Villacoublay, France
Tel: 01-30-67 58 00
Fax: 01-30-67 58 99

NEC Electronics (France) S.A.

Spain Office
Madrid, Spain
Tel: 01-504-2787
Fax: 01-504-2860

NEC Electronics (Germany) GmbH

Scandinavia Office
Taebly, Sweden
Tel: 08-63 80 820
Fax: 08-63 80 388

NEC Electronics Hong Kong Ltd.

Hong Kong
Tel: 2886-9318
Fax: 2886-9022/9044

NEC Electronics Hong Kong Ltd.

Seoul Branch
Seoul, Korea
Tel: 02-528-0303
Fax: 02-528-4411

NEC Electronics Singapore Pte. Ltd.

United Square, Singapore 1130
Tel: 253-8311
Fax: 250-3583

NEC Electronics Taiwan Ltd.

Taipei, Taiwan
Tel: 02-719-2377
Fax: 02-719-5951

NEC do Brasil S.A.

Sao Paulo-SP, Brasil
Tel: 011-889-1680
Fax: 011-889-1689

[MEMO]

NOTES FOR CMOS DEVICES

① PRECAUTION AGAINST ESD FOR SEMICONDUCTORS

Note: Strong electric field, when exposed to a MOS device, can cause destruction of the gate oxide and ultimately degrade the device operation. Steps must be taken to stop generation of static electricity as much as possible, and quickly dissipate it once, when it has occurred. Environmental control must be adequate. When it is dry, humidifier should be used. It is recommended to avoid using insulators that easily build static electricity. Semiconductor devices must be stored and transported in an anti-static container, static shielding bag or conductive material. All test and measurement tools including work bench and floor should be grounded. The operator should be grounded using wrist strap. Semiconductor devices must not be touched with bare hands. Similar precautions need to be taken for PW boards with semiconductor devices on it.

② HANDLING OF UNUSED INPUT PINS FOR CMOS

Note: No connection for CMOS device inputs can be cause of malfunction. If no connection is provided to the input pins, it is possible that an internal input level may be generated due to noise, etc., hence causing malfunction. CMOS devices behave differently than Bipolar or NMOS devices. Input levels of CMOS devices must be fixed high or low by using a pull-up or pull-down circuitry. Each unused pin should be connected to V_{DD} or GND with a resistor, if it is considered to have a possibility of being an output pin. All handling related to the unused pins must be judged device by device and related specifications governing the devices.

③ STATUS BEFORE INITIALIZATION OF MOS DEVICES

Note: Power-on does not necessarily define initial status of MOS device. Production process of MOS does not define the initial operation status of the device. Immediately after the power source is turned ON, the devices with reset function have not yet been initialized. Hence, power-on does not guarantee out-pin levels, I/O settings or contents of registers. Device is not initialized until the reset signal is received. Reset operation must be executed immediately after power-on for devices having reset function.

[MEMO]

The documents referred to in this publication may include preliminary versions. However, preliminary versions are not marked as such.

V20, V30, V25, V35, V25+, V55PI are trademarks of NEC Corporation.

No part of this document may be copied or reproduced in any form or by any means without the prior written consent of NEC Corporation. NEC Corporation assumes no responsibility for any errors which may appear in this document.

NEC Corporation does not assume any liability for infringement of patents, copyrights or other intellectual property rights of third parties by or arising from use of a device described herein or any other liability arising from use of such device. No license, either express, implied or otherwise, is granted under any patents, copyrights or other intellectual property rights of NEC Corporation or others.

While NEC Corporation has been making continuous effort to enhance the reliability of its semiconductor devices, the possibility of defects cannot be eliminated entirely. To minimize risks of damage or injury to persons or property arising from a defect in an NEC semiconductor device, customers must incorporate sufficient safety measures in its design, such as redundancy, fire-containment, and anti-failure features.

NEC devices are classified into the following three quality grades:

"Standard", "Special", and "Specific". The Specific quality grade applies only to devices developed based on a customer designated "quality assurance program" for a specific application. The recommended applications of a device depend on its quality grade, as indicated below. Customers must check the quality grade of each device before using it in a particular application.

Standard: Computers, office equipment, communications equipment, test and measurement equipment, audio and visual equipment, home electronic appliances, machine tools, personal electronic equipment and industrial robots

Special: Transportation equipment (automobiles, trains, ships, etc.), traffic control systems, anti-disaster systems, anti-crime systems, safety equipment and medical equipment (not specifically designed for life support)

Specific: Aircrafts, aerospace equipment, submersible repeaters, nuclear reactor control systems, life support systems or medical equipment for life support, etc.

The quality grade of NEC devices is "Standard" unless otherwise specified in NEC's Data Sheets or Data Books. If customers intend to use NEC devices for applications other than those specified for Standard quality grade, they should contact an NEC sales representative in advance.

Anti-radioactive design is not implemented in this product.