

## General Description

The IDTVS330 is a true bidirectional Quad 2-channel multiplexer/ demultiplexer recommended for both RGB and composite video switching applications. The video switch can be driven from a current output RAMDAC or voltage output composite video source.

Low On-Resistance and wide bandwidth make it ideal for video and other applications. Also this device has exceptionally high current capability which is far greater than most analog switches offered today. A single 5V supply is all that is required for operation.

The IDTVS330 offers a high-performance, low-cost solution to switch between video sources. The application section describes the IDTVS330 replacing the HC4053 multiplier and buffer/ amplifier.

## Features

- High-performance solution to switch between video sources
- Wide bandwidth: 600MHz
- Low On-Resistance: 5Ω typical
- Low crosstalk at 10MHz: -80dB
- Ultra-low quiescent power (0.1μA typical)
- Fast switching: 10ns
- 8KV ESD HBM on connector side
- Available in SOIC and QSOP packages

## Block Diagram

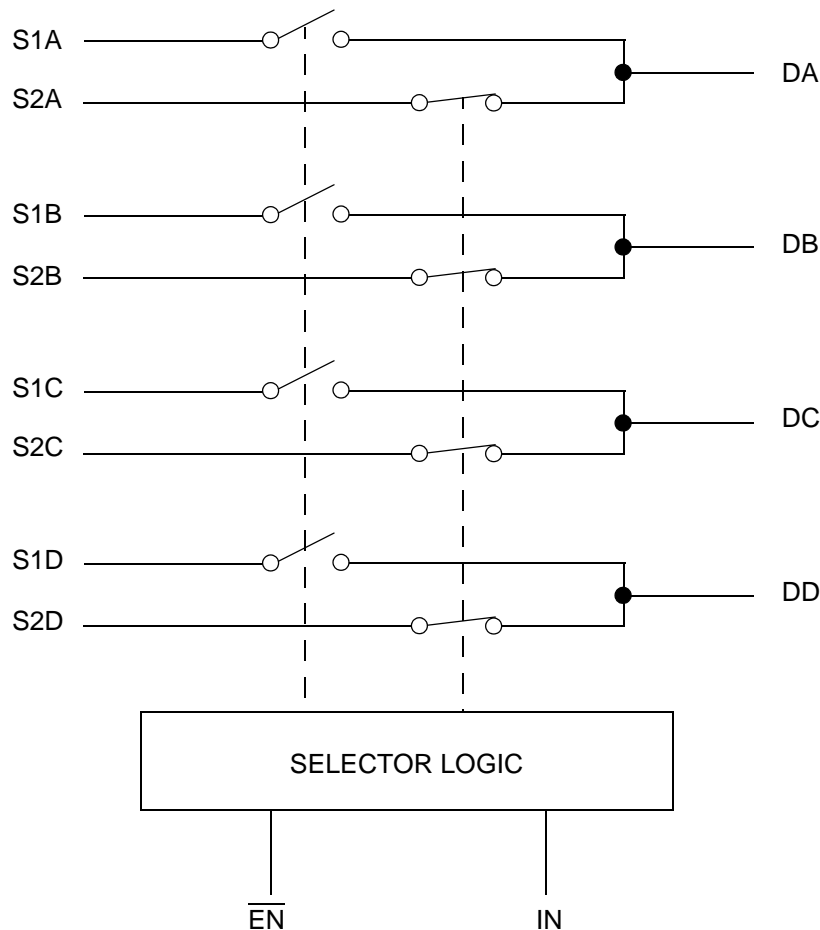

## Pin Configuration

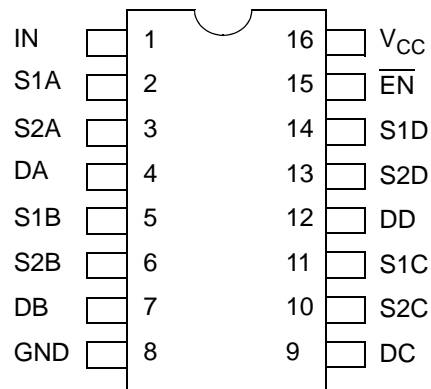

SOIC/ QSOP  
TOP VIEW

## Absolute Maximum Ratings

Symbol	Rating	Min	Max <sup>1</sup>	Unit
TSTG	Storage Temperature Range	- 65	+150	°C
	Ambient Temperature with Power Applied	0	+70	°C
	Supply Voltage to GND Potential	- 0.5	+5.5	V
	DC Input Voltage	- 0.5	+5.5	V
	DC Output Current	—	120	mA
	Power Dissipation	—	0.5	W

1. Stresses greater than those listed under ABSOLUTE MAXIMUM RATINGS may cause permanent damage to the device. This is a stress rating only and functional operation of the device at these or any other conditions above those indicated in the operational sections of this specification is not implied. Exposure to absolute maximum rating conditions for extended periods may affect reliability.

## Truth Table

$\overline{\text{EN}}$	IN	ON Switch
L	L	S1A, S1B, S1C, S1D
L	H	S2A, S2B, S2C, S2D
H	X	Disabled

## Pin Description

Name	Function
S1, S2	Analog Video I/Os
IN	Select Input
EN	Enable
D	Analog Video I/O
GND	Ground
V <sub>CC</sub>	Power Supply

## DC Electrical Characteristics Over Operating Range

Following Conditions Apply Unless Otherwise Specified:

T<sub>A</sub> = 0°C to +70°C, V<sub>CC</sub> = 3.3V ± 5%.

Symbol	Parameter	Conditions <sup>1</sup>	Min.	Typ. <sup>2</sup>	Max.	Unit
V <sub>ANALOG</sub>	Analog Signal Range		0	—	V <sub>CC</sub>	V
V <sub>IH</sub>	Input HIGH Voltage	Guaranteed Logic HIGH level	2	—	—	V
V <sub>IL</sub>	Input LOW Voltage	Guaranteed Logic LOW level	0	—	0.8	
I <sub>IH</sub>	Input HIGH Current	V <sub>CC</sub> = Max., V <sub>IN</sub> = V <sub>CC</sub>	—	—	±1	μA
I <sub>IL</sub>	Input LOW Current	V <sub>CC</sub> = Max., V <sub>IN</sub> = V <sub>SS</sub>	—	—	±1	
I <sub>O</sub>	Analog Output Leakage Current	0 ≤ S1, S2 or D ≤ V <sub>CC</sub> , Switch OFF	—	—	±1	μA
V <sub>IK</sub>	Clamp Diode Voltage	V <sub>CC</sub> = Min., I <sub>IN</sub> = -18mA	-0.7	-1.2	—	V
V <sub>H</sub>	Input Hysteresis at Control Pins		—	150	—	mV
R <sub>ON</sub> <sup>3</sup>	Switch On-Resistance	V <sub>CC</sub> = Min., V <sub>IN</sub> = 1V, I <sub>ON</sub> = 13mA	—	5	7	Ω
		V <sub>CC</sub> = Min., V <sub>IN</sub> = 2V, I <sub>ON</sub> = 26mA	—	7	10	

1. For Max. or Min. conditions, use appropriate value specified under Electrical Characteristics for the applicable device type.
2. Typical values are at V<sub>CC</sub> = 3.3V, T<sub>A</sub> = 25°C ambient and maximum loading.
3. Measured by the voltage drop between S1, S2, and D I/O pins at indicated current through the switch. On-Resistance is determined by the lower of the voltages on the S1, S2, and D I/O pins.

## Dynamic Electrical Characteristics Over Operating Range

Following Conditions Apply Unless Otherwise Specified:

$T_A = 0^\circ\text{C}$  to  $+70^\circ\text{C}$ ,  $V_{CC} = 3.3\text{V} \pm 5\%$ .

Symbol	Parameter	Conditions	Min.	Typ.	Max.	Unit
$t_{ON}$	Turn On Time	$R_L = 75\Omega$ , $C_L = 20\text{pF}$	—	2.5	5	ns
$t_{OFF}$	Turn Off Time	$R_L = 75\Omega$ , $C_L = 20\text{pF}$	—	1.1	5	
$B_W^1$	-3dB Bandwidth		—	—	570	MHz
$X_{TALK}^1$	Crosstalk	10MHz, $C_L = 0\text{pF}$	—	-80	—	dB
$C_{IN}^1$	Input/Enable Capacitance	$V_{IN} = 0\text{V}$ , $f = 1\text{MHz}$	—	—	6	pF
$C_{OFF}^1$	Capacitance, Switch Off		—	—	6	
$C_{ON}^1$	Capacitance, Switch On		—	—	9	
$O_{IRR}$	Off Isolation	10MHz, $C_L = 0\text{pF}$	—	-48	—	dB

1. This parameter is determined by device characterization but is not production tested.

## DC Electrical Characteristics Over Operating Range

Following Conditions Apply Unless Otherwise Specified:

$T_A = 0^\circ\text{C}$  to  $+70^\circ\text{C}$ ,  $V_{CC} = 5\text{V} \pm 5\%$ .

Symbol	Parameter	Conditions <sup>1</sup>	Min.	Typ. <sup>2</sup>	Max.	Unit
$V_{ANALOG}$	Analog Signal Range		0	—	$V_{CC}$	V
$V_{IH}$	Input HIGH Voltage	Guaranteed Logic HIGH level	2	—	—	V
$V_{IL}$	Input LOW Voltage	Guaranteed Logic LOW level	-0.5	—	0.8	
$I_{IH}$	Input HIGH Current	$V_{CC} = \text{Max.}$ , $V_{IN} = V_{CC}$	—	—	$\pm 1$	$\mu\text{A}$
$I_{IL}$	Input LOW Current	$V_{CC} = \text{Max.}$ , $V_{IN} = V_{SS}$	—	—	$\pm 1$	
$I_O$	Analog Output Leakage Current	$0 \leq S1, S2$ or $D \leq V_{CC}$ , Switch OFF	—	—	$\pm 1$	$\mu\text{A}$
$V_{IK}$	Clamp Diode Voltage	$V_{CC} = \text{Min.}$ , $I_{IN} = -18\text{mA}$	-0.7	-1.2	—	V
$I_{OS}^3$	Short Circuit Current		100	—	—	mA
$V_H$	Input Hysteresis at Control Pins	$V_{CC} = \text{Min.}$ , $V_{IN} = 1\text{V}$ , $R_L = 75\Omega$ , $I_{ON} = 13\text{mA}$	—	150	—	mV
$R_{ON}^4$	Switch On-Resistance	$V_{CC} = \text{Min.}$ , $V_{IN} = 2\text{V}$ , $R_L = 75\Omega$ , $I_{ON} = 26\text{mA}$	3	7	10	$\Omega$

1. For Max. or Min. conditions, use appropriate value specified under Electrical Characteristics for the applicable device type.

2. Typical values are at  $V_{CC} = 5\text{V}$ ,  $T_A = 25^\circ\text{C}$  ambient and maximum loading.

3. Not more than one output should be shorted at one time. Duration of the test should not exceed one second.

4. Measured by the voltage drop between S1, S2, and D I/O pins at indicated current through the switch. On-Resistance is determined by the lower of the voltages on the S1, S2, and D I/O pins.

## Dynamic Electrical Characteristics Over Operating Range

Following Conditions Apply Unless Otherwise Specified:

$T_A = 0^\circ\text{C}$  to  $+70^\circ\text{C}$ ,  $V_{CC} = 3.3\text{V} \pm 5\%$ .

Symbol	Parameter	Conditions	Min.	Typ.	Max.	Unit
$t_{ON}$	Turn On Time	$R_L = 75\Omega$ , $C_L = 20\text{pF}$	—	2.5	5	ns
$t_{OFF}$	Turn Off Time	$R_L = 75\Omega$ , $C_L = 20\text{pF}$	—	1.1	5	
$B_W^1$	-3dB Bandwidth	$R_L = 150\Omega$	—	—	570	MHz
$X_{TALK}$	Crosstalk	$R_{IN} = 10\Omega$ , $R_L = 150\Omega$ , 10MHz	—	-58	—	dB
$D_G$	Differential Gain	$R_L = 150\Omega$ , $f = 3.58\text{MHz}$	—	0.64	—	%
$D_P$	Differential Phase	$R_L = 150\Omega$ , $f = 3.58\text{MHz}$	—	0.27	—	Deg.
$C_{IN}^1$	Input/Enable Capacitance	$V_{IN} = 0\text{V}$ , $f = 1\text{MHz}$	—	—	6	pF
$C_{OFF}^1$	Capacitance, Switch Off		—	—	6	
$C_{ON}^1$	Capacitance, Switch On		—	—	8	
$O_{IRR}$	Off Isolation	$R_L = 150\Omega$ , 10MHz	—	-38	—	dB

1. This parameter is determined by device characterization but is not production tested.

## Power Supply Characteristics

Symbol	Parameter	Conditions <sup>1</sup>	Min.	Typ. <sup>2</sup>	Max.	Unit
$I_{CC}$	Quiescent Power Supply Current	$V_{CC} = \text{Max.}$ , $I_N = \text{GND}$ or $V_{CC}$	—	0.1	3	$\mu\text{A}$
$\Delta I_{CC}$	Power Supply Current per Input @ TTL HIGH	$V_{CC} = \text{Max.}$ , $I_N = 3.4\text{V}^3$	—	—	2.5	mA
$I_{CCD}^4$	Supply Current per Input per MHz	$V_{CC} = \text{Max.}$ , S1, S2 and D Pins Open, $\overline{EN} = \text{GND}$ Control Input Toggling, 50%Duty Cycle	—	—	0.25	mA/MHz

1. For Max. or Min. conditions, use appropriate value specified under Electrical Characteristics for the applicable device.
2. Typical values are at  $V_{CC} = 5.0\text{V}$ ,  $+25^\circ\text{C}$  ambient.
3. Per TTL driven input ( $V_{IN} = 3.4\text{V}$ , control inputs only); S1, S2, and D pins do not contribute to  $I_{CC}$ .
4. This current applies to the control inputs only and represent the current required to switch internal capacitance at the specified frequency. The S1, S2, and D I/O pins generate no significant AC or DC currents as they transition. This parameter is not tested, but is guaranteed by design.

### Test Circuit for Electrical Characteristics

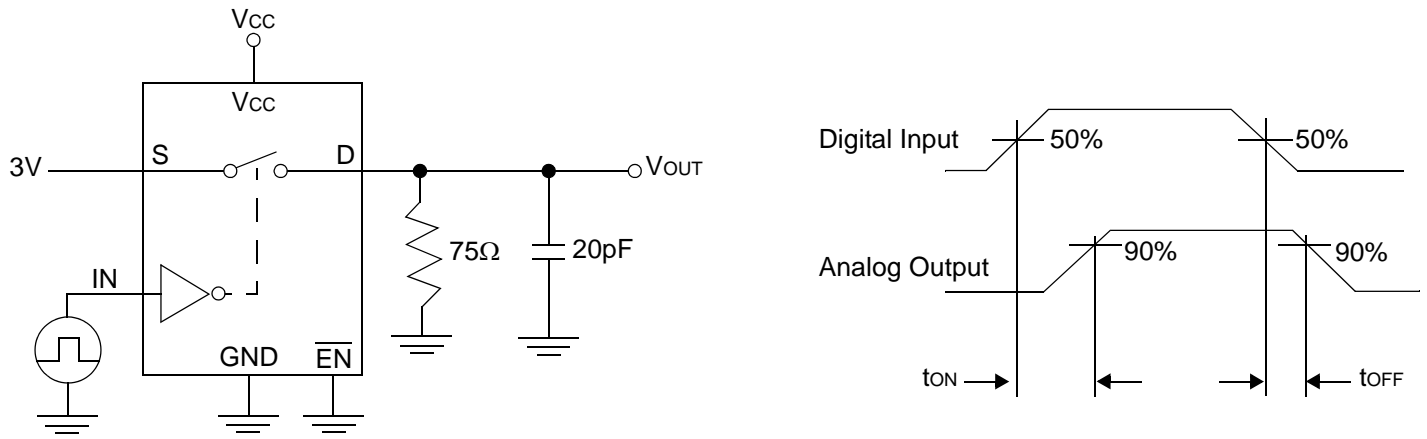

Figure 1. Switching Time

### Test Circuit for Dynamic Electrical Characteristics

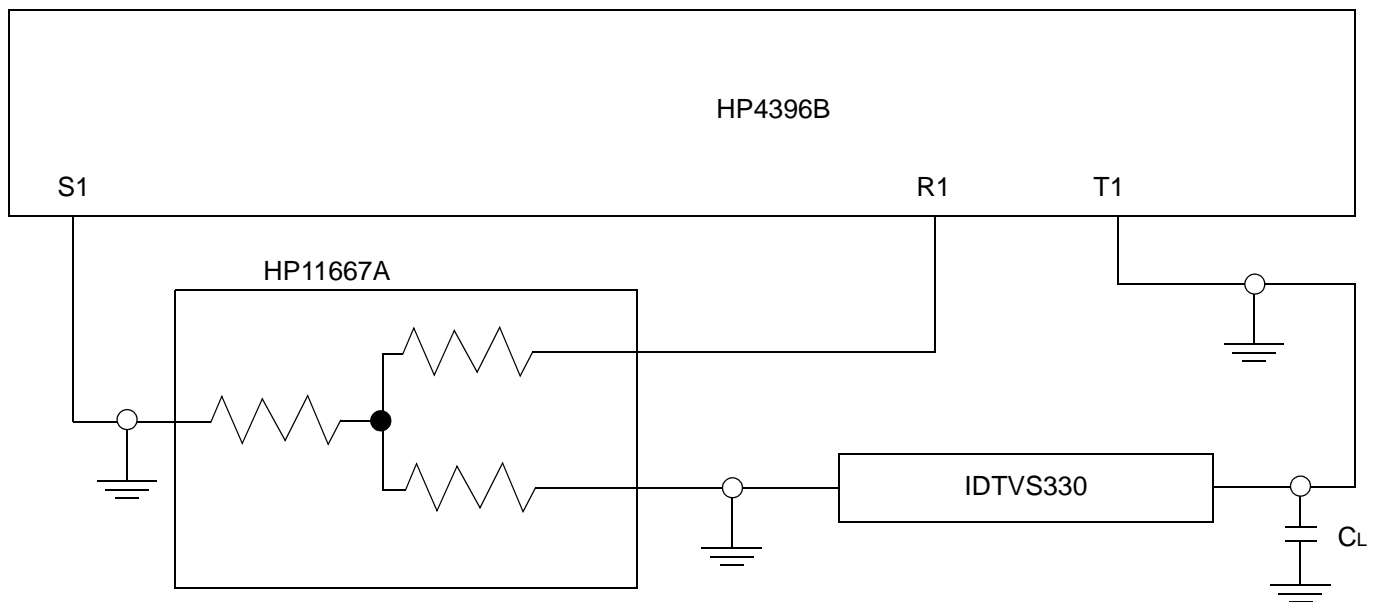
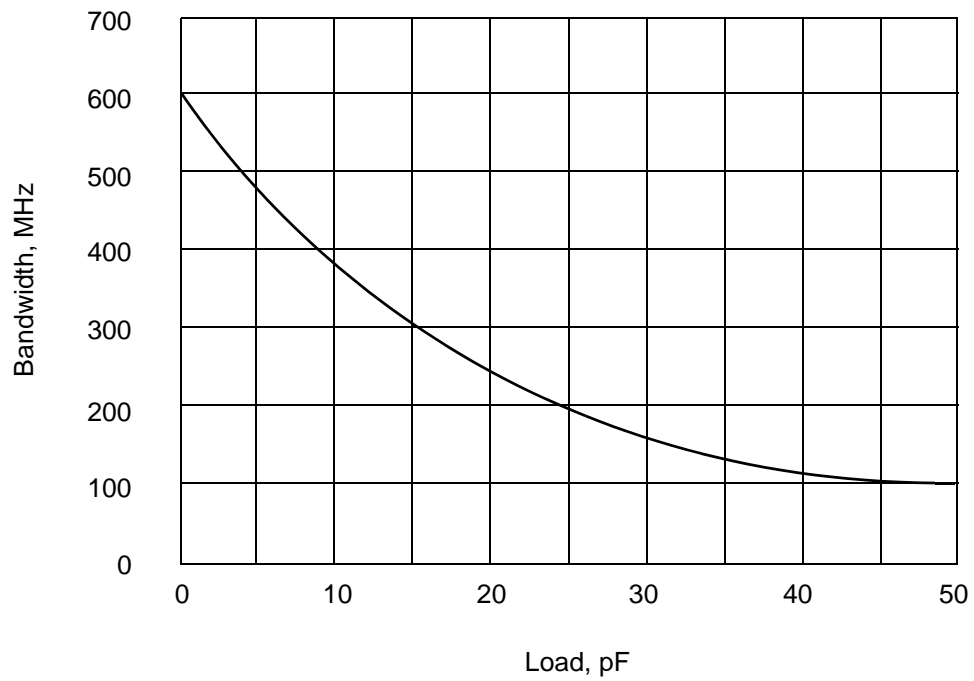
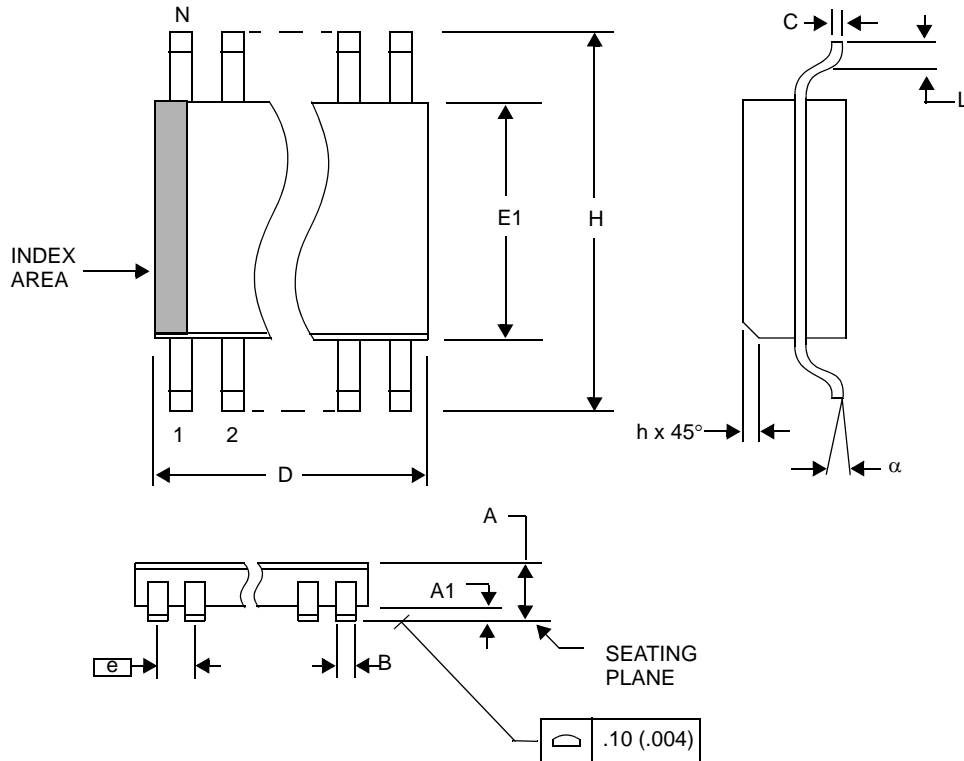

Figure 2. Gain/Phase, Crosstalk, Off-Isolation



**Figure 3.** Bandwidth vs Load

### Package Dimensions - SOIC



### 150 mil (Narrow Body) SOIC

Symbol	In Millimeters Common Dimensions		In Inches Common Dimensions <sup>1</sup>	
	MIN	MAX	MIN	MAX
A	1.35	1.75	.0532	.0688
A1	0.10	0.25	.0040	.0098
B	0.33	0.51	.0130	.0200
C	0.19	0.25	.0075	.0098
D	9.80	10.00	.3859	.3937
E	3.80	4.00	.1497	.1574
e	1.27 BASIC		0.050 BASIC	
H	5.80	6.20	.2284	.2440
h	0.25	0.50	.010	.020
L	0.40	1.27	.016	.050
N	16		16	
α	0°	8°	0°	8°

1. For reference only. Controlling dimensions are in mm.



### Package Dimensions - QSOP

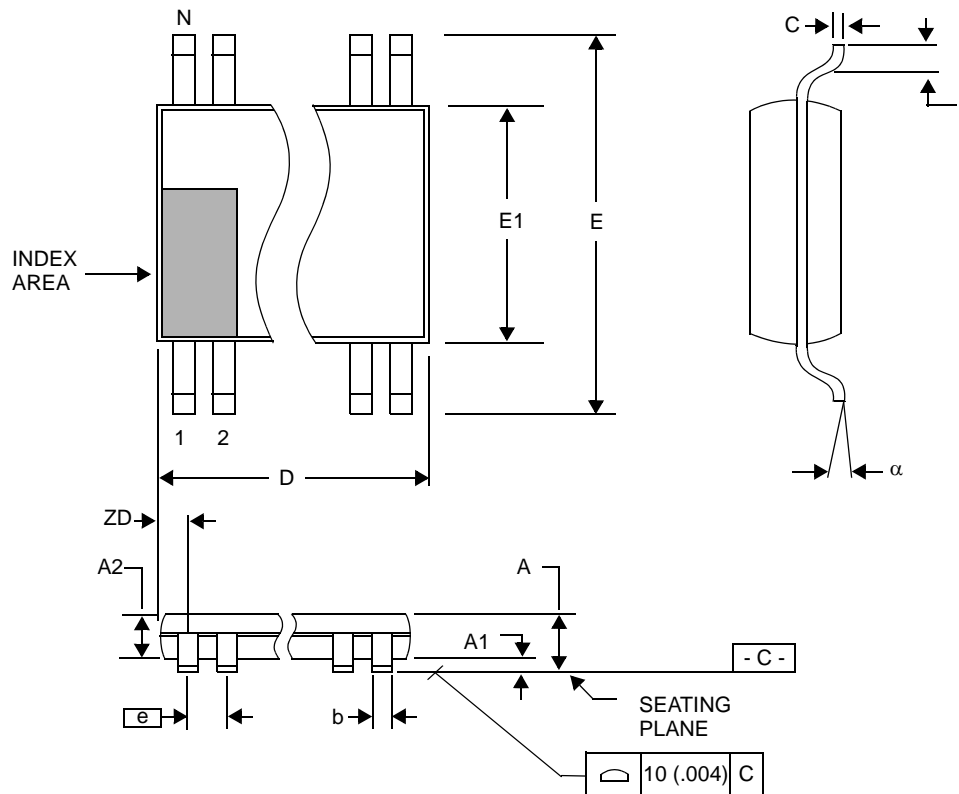

### 150 mil SSOP (QSOP)

Symbol	In Millimeters Common Dimensions <sup>1</sup>		In Inches Common Dimensions	
	MIN	MAX	MIN	MAX
A	1.35	1.75	.053	.069
A1	0.10	0.25	.004	.010
A2	—	1.50	—	.059
b	0.20	0.30	.008	.012
c	0.18	0.25	.007	.010
D	4.80	5.00	.189	.197
E	5.80	6.20	.228	.244
E1	3.80	4.00	.150	.157
e	0.635 BASIC		0.025 BASIC	
L	0.40	1.27	.016	.050
N	16		16	
á	0°	8°	0°	8°
ZD	.23 Ref		.009 Ref	

1. For reference only. Controlling dimensions are in inches.

## Ordering Information

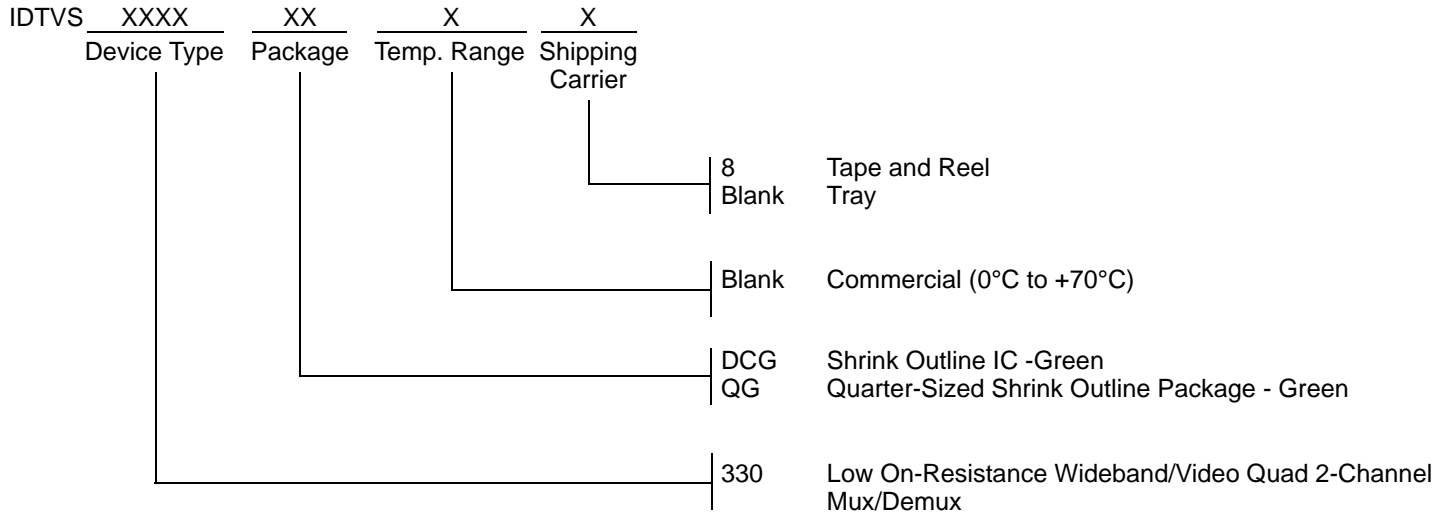

## IMPORTANT NOTICE AND DISCLAIMER

RENESAS ELECTRONICS CORPORATION AND ITS SUBSIDIARIES (“RENESAS”) PROVIDES TECHNICAL SPECIFICATIONS AND RELIABILITY DATA (INCLUDING DATASHEETS), DESIGN RESOURCES (INCLUDING REFERENCE DESIGNS), APPLICATION OR OTHER DESIGN ADVICE, WEB TOOLS, SAFETY INFORMATION, AND OTHER RESOURCES “AS IS” AND WITH ALL FAULTS, AND DISCLAIMS ALL WARRANTIES, EXPRESS OR IMPLIED, INCLUDING, WITHOUT LIMITATION, ANY IMPLIED WARRANTIES OF MERCHANTABILITY, FITNESS FOR A PARTICULAR PURPOSE, OR NON-INFRINGEMENT OF THIRD-PARTY INTELLECTUAL PROPERTY RIGHTS.

These resources are intended for developers who are designing with Renesas products. You are solely responsible for (1) selecting the appropriate products for your application, (2) designing, validating, and testing your application, and (3) ensuring your application meets applicable standards, and any other safety, security, or other requirements. These resources are subject to change without notice. Renesas grants you permission to use these resources only to develop an application that uses Renesas products. Other reproduction or use of these resources is strictly prohibited. No license is granted to any other Renesas intellectual property or to any third-party intellectual property. Renesas disclaims responsibility for, and you will fully indemnify Renesas and its representatives against, any claims, damages, costs, losses, or liabilities arising from your use of these resources. Renesas' products are provided only subject to Renesas' Terms and Conditions of Sale or other applicable terms agreed to in writing. No use of any Renesas resources expands or otherwise alters any applicable warranties or warranty disclaimers for these products.

(Disclaimer Rev.1.01)

### Corporate Headquarters

TOYOSU FORESIA, 3-2-24 Toyosu,  
Koto-ku, Tokyo 135-0061, Japan  
[www.renesas.com](http://www.renesas.com)

### Trademarks

Renesas and the Renesas logo are trademarks of Renesas Electronics Corporation. All trademarks and registered trademarks are the property of their respective owners.

### Contact Information

For further information on a product, technology, the most up-to-date version of a document, or your nearest sales office, please visit [www.renesas.com/contact-us/](http://www.renesas.com/contact-us/).