

## Brief Description

The ZSSC3122 is a CMOS integrated circuit for accurate capacitance-to-digital conversion and sensor-specific correction of capacitive sensor signals. Digital compensation of sensor offset, sensitivity, and temperature drift is accomplished via an internal digital signal processor running a correction algorithm with calibration coefficients stored in a non-volatile EEPROM.

The ZSSC3122 is configurable for capacitive sensors with capacitances up to 10pF and a sensitivity of 125aF/LSB. It is compatible with both single capacitive sensors (both terminals must be accessible) and differential capacitive sensors. Measured and corrected sensor values can be output as I2C, SPI, PDM, or alarms.

The I2C interface can be used for a simple PC-controlled calibration procedure to program a set of calibration coefficients into an on-chip EEPROM. The calibrated ZSSC3122 and a specific sensor are mated digitally: fast, precise, and without the cost overhead of trimming by external devices or laser.

## Available Support

- ZSSC3122 SSC Evaluation Kit available: SSC Evaluation Board, samples, software, documentation.
- Support for industrial mass calibration available.
- Quick circuit customization option for large production volumes.

## Application Circuit: Digital Output, Alarms

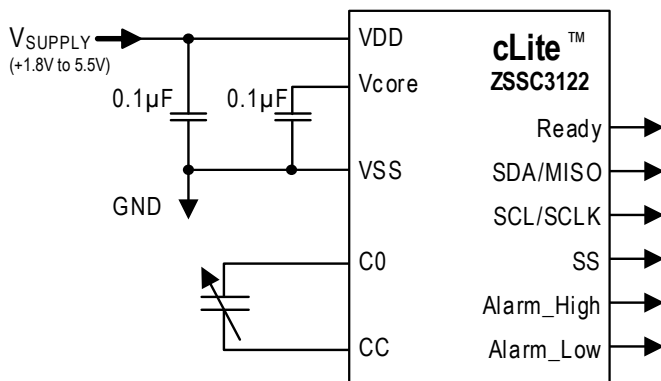

## Features

- Maximum target input capacitance: 10pF
- Sampling rates as fast as 0.7ms at 8-bit resolution; 1.6ms at 10-bit; 5.0ms at 12-bit; 18.5ms at 14-bit
- Digital compensation of sensor: piece-wise 1st and 2nd order sensor compensation or up to 3<sup>rd</sup> order single-region sensor compensation
- Digital compensation of 1st and 2nd order temperature gain and offset drift
- Internal temperature compensation reference (no external components)
- Programmable capacitance span and offset
- Layout customized for die-die bonding with sensor for low-cost, high-density chip-on-board assembly
- Accuracy as high as ±0.25% FSO@ -20 to 125°C, 3V, 5V, V<sub>supply</sub> ±10% (see data sheet section 1.3 for restrictions)
- Minimized calibration costs: no laser trimming, one-pass calibration using a digital interface
- Excellent for low-power battery applications
- Two interface options
  - I2C or SPI interface—easy connection to a microcontroller
  - PDM outputs (Filtered Analog Ratiometric) for both capacitance and temperature
- Up to two alarms that can act as full push-pull or open-drain switches
- Supply voltage: 1.8 to 5.5V
- Typical current consumption 650µA down to 60µA depending on configuration
- Typical Sleep Mode current: ≤ 1µA at 85°C
- Operation temperature: -20°C to +125°C
- Die or TSSOP14 package

## Contents

1. Pin Assignments .....	6
2. Pin Descriptions .....	6
3. Absolute Maximum Ratings .....	7
4. Operating Conditions .....	7
5. Electrical Characteristics .....	8
6. Current Consumption Graphs .....	11
6.1 Update Mode Current Consumption .....	11
6.2 Sleep Mode Current Consumption .....	11
7. Output Pad Drive Strength .....	12
8. Temperature Sensor Nonlinearity .....	13
9. Circuit Description .....	14
9.1 Signal Flow and Block Diagram .....	14
9.2 Analog Front-End .....	15
9.2.1 Capacitance-to-Digital Converter .....	15
9.2.2 Temperature Measurement .....	18
9.3 Digital Core .....	19
10. Normal Operation Mode .....	20
10.1 Power-On Sequence .....	21
10.2 Measurement Cycle .....	21
10.3 Measurement Modes .....	22
10.3.1 Update Mode .....	22
10.3.2 Sleep Mode .....	25
10.4 Status and Diagnostics .....	26
10.4.1 EEPROM Error Detection and Correction .....	27
10.4.2 Alarm Diagnostics .....	27
10.5 Output Modes .....	28
10.6 I2C and SPI .....	28
10.6.1 I2C Features and Timing .....	28
10.6.2 SPI Features and Timing .....	30
10.6.3 I2C and SPI Commands .....	30
10.6.4 Data Fetch (DF) .....	31
10.6.5 Measurement Request (MR) .....	32
10.6.6 Ready Pin .....	33
10.7 PDM (Pulse Density Modulation) .....	33
10.8 Alarm Output .....	34
10.8.1 Alarm Registers .....	35
10.8.2 Alarm Operation .....	35
10.8.3 Alarm Output Configuration .....	36
10.8.4 Alarm Polarity .....	36

11. Command Mode .....	37
11.1 Command Format.....	37
11.2 Command Encodings .....	38
11.3 Command Response and Data Fetch .....	38
12. EEPROM .....	41
12.1 IDT Configuration Register (ZMDI_Config, EEPROM Word 02 <sub>HEX</sub> ).....	43
12.2 Capacitance Analog Front-End Configuration (C_Config, EEPROM Word 06 <sub>HEX</sub> ).....	44
12.3 Temperature Analog Front-End Configuration (T_Config, EEPROM Word 11 <sub>HEX</sub> ).....	45
12.4 Customer Configuration Register (Cust_Config, EEPROM Word 1C <sub>HEX</sub> ).....	46
13. Calibration and Signal Conditioning Math.....	47
13.1 Capacitance Signal Conditioning.....	47
13.2 Temperature Signal Compensation.....	48
13.3 Limits on Coefficient Ranges.....	48
14. Application Circuit Examples .....	49
14.1 Digital Output with Optional Alarms.....	49
14.2 Analog Output with Optional Alarms.....	50
14.3 Bang-Bang Control System .....	51
14.4 Differential Input Capacitance .....	52
14.5 External Reference Capacitor .....	53
15. ESD/Latch-Up-Protection .....	54
16. Test.....	54
17. Reliability .....	54
18. Customization.....	54
19. Package Outline Drawings .....	55
20. Example Marking Diagram for TSSOP14 Parts.....	55
21. Storage and Soldering Conditions.....	55
22. Glossary .....	55
23. Ordering Information.....	56
24. Document Revision History .....	56

## List of Figures

Figure 1.1	Pin Assignments for 4.4 × 5.0 mm 14-TSSOP – Top View.....	6
Figure 6.1	Best Case Settings (Typical Part).....	11
Figure 6.2	Worst Case Settings (Typical Part) .....	11
Figure 6.3	Typical Current Consumption during Sleep Mode (No Measurements) .....	11
Figure 7.1	Output High Drive Strength Graph .....	12
Figure 7.2	Output Low Drive Strength Graph .....	12
Figure 8.1	First Order Fit (Typical Part) .....	13
Figure 8.2	Second Order Fit (Typical Part).....	13
Figure 9.1	ZSSC3122 Block Diagram.....	14
Figure 10.1	General Operation .....	20
Figure 10.2	Power-On Sequence with Fast Startup Bit Set in EEPROM .....	21
Figure 10.3	Measurement Cycle Timing .....	22
Figure 10.4	Measurement Sequence in Update Mode .....	23
Figure 10.5	I2C and SPI Data Fetching in Update Mode.....	24
Figure 10.6	Measurement Sequence in Sleep Mode (Only I2C, SPI, or Alarms) .....	25
Figure 10.7	I2C and SPI Data Fetching in Sleep Mode .....	26
Figure 10.8	I2C Timing Diagram.....	29
Figure 10.9	SPI Timing Diagram .....	30
Figure 10.10	I2C Measurement Packet Reads.....	31
Figure 10.11	SPI Output Packet with Positive Edge Sampling.....	32
Figure 10.12	I2C MR .....	32
Figure 10.13	SPI MR .....	33
Figure 10.14	Example of Alarm Function .....	35
Figure 10.15	Alarm Output Flow Chart.....	36
Figure 11.1	I2C Command Format .....	37
Figure 11.2	Command Mode Data Fetch .....	40
Figure 14.1	Digital Output with Optional Alarms Example.....	49
Figure 14.2	Analog Output with Optional Alarms Example.....	50
Figure 14.3	Bang-Bang Control System Example .....	51
Figure 14.4	Differential Input Capacitance Example .....	52
Figure 14.5	Ext. Reference Input Capacitance Example.....	53

## List of Tables

Table 2.1	ZSSC3122 Pin Assignments for TSSOP-14.....	6
Table 9.1	Selection Settings for $C_{REF}$ and $C_{OFF}$ .....	17
Table 10.1	CDC Resolution and Conversion Times.....	22
Table 10.2	Update Rate Settings.....	23
Table 10.3	Time Periods between Capacitance Measurements and Temperature Measurements for Different Resolution and Update Rates.....	24
Table 10.4	Status Table.....	27
Table 10.5	Diagnostic Detection.....	27
Table 10.6	Normal Operation Diagnostic Table.....	27
Table 10.7	Output Modes.....	28
Table 10.8	Pin Assignment for Output Selections.....	28
Table 10.9	I2C Parameters.....	29
Table 10.10	SPI Parameters.....	30
Table 10.11	I2C and SPI Command Types.....	30
Table 10.12	Low Pass Filter Example for $R = 10k\Omega$ .....	34
Table 11.1	Command List and Encodings.....	38
Table 11.2	Response Bits.....	39
Table 11.3	Command Diagnostic Bits.....	39
Table 12.1	EEPROM Word Assignments.....	41
Table 12.2	ZMDI_Config Bit Assignments.....	43
Table 12.3	C_Config Bit Assignments.....	44
Table 12.4	T_Config Bit Assignments.....	45
Table 12.5	Cust_Config Bit Assignments.....	46
Table 13.1	Limits on Coefficient Ranges.....	48
Table 14.1	Example 1: Configuration Settings.....	49
Table 14.2	Example 2: Configuration Settings.....	50
Table 14.3	Example 3: Configuration Settings.....	51
Table 14.4	Example 4: Configuration Settings.....	52
Table 14.5	Example 5: Configuration Settings.....	53
Table 21.1	TSSOP14 Storage and Soldering Conditions.....	55

## 1. Pin Assignments

The standard package for the ZSSC3122 is a 14-TSSOP (4.4 ±0.1mm × 5.0 ±0.1mm) with lead-pitch 0.65mm.

**Figure 1.1 Pin Assignments for 4.4 × 5.0 mm 14-TSSOP – Top View**

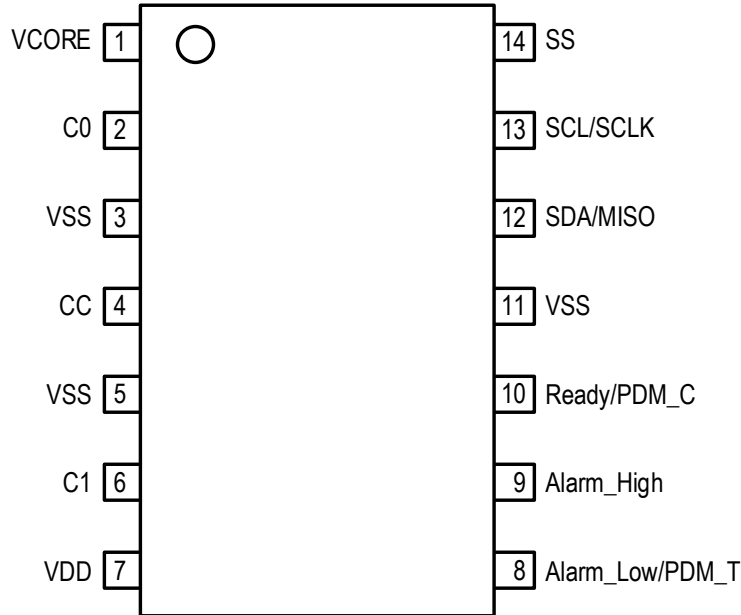

## 2. Pin Descriptions

**Table 2.1 ZSSC3122 Pin Assignments for TSSOP-14**

Pin	Name	Description	Notes
1	VCORE	Core voltage	Always connect to an external capacitor to Gnd that is within the specifications given in section 5 for C <sub>VCORE_SM</sub> and C <sub>VCORE_UM</sub> . This is the only internal module pin. Refer to section 15 for ESD details.
2	C0	Capacitor input 0	
3	VSS	Ground supply	Connecting to GND for shielding is strongly recommended.
4	CC	Common capacitor input	
5	VSS	Ground supply	Connecting to GND for shielding is strongly recommended.
6	C1	Capacitor input 1	If not used, must be unconnected.
7	VDD	Supply voltage (1.8V to 5.5V)	Must connect to V <sub>supply</sub> .
8	Alarm_Low/PDM_T	Low alarm output Temperature PDM (see Table 10.8)	If not used, must be unconnected.

Pin	Name	Description	Notes
9	Alarm_High	High alarm output	If not used, must be unconnected.
10	Ready/PDM_C	Ready signal (conversion complete output) Capacitance PDM (see Table 10.8)	If not used, must be unconnected.
11	VSS	Ground supply	Must connect to GND.
12	SDA/MISO	I2C data if in I2C Mode Master-In-Slave-Out if in SPI Mode (see Table 10.8)	If not used, must connect to VDD.
13	SCL/SCLK	I2C clock if in I2C Mode Serial clock if in SPI Mode (see Table 10.8)	If not used, must connect to VDD.
14	SS	Slave Select (input) if in SPI Mode (see Table 10.8)	If not used, must be unconnected.

### 3. Absolute Maximum Ratings

Parameter	Symbol	Min	Typ	Max	Units
Analog Supply Voltage	$V_{DD}$	-0.3		6.0	V
Voltages at Analog I/O – In Pin	$V_{INA}$	-0.3		$V_{DD}+0.3$	V
Voltages at Analog I/O – Out Pin	$V_{OUTA}$	-0.3		$V_{DD}+0.3$	V
Storage Temperature Range	$T_{STOR}$	-55		150	°C

### 4. Operating Conditions

See important footnotes at the end of the following table.

Parameter	Symbol	Min	Typ	Max	Units
Supply Voltage to Gnd	$V_{SUPPLY}$	1.8		5.5	V
Ambient Temperature Range <sup>[a]</sup>	$T_{AMB}$	-20		125	°C
Output Pads/Pins Drive Strength <sup>[b]</sup>	$I_{OUT}$	1.5		20	mA
External Capacitance between $V_{DD}$ pin and Gnd	$C_{VSUPPLY}$	100	220	470	nF
External Capacitance between $V_{core}$ and Gnd—Sleep Mode	$C_{VCORE\_SM}$	10		110	nF
External Capacitance between $V_{core}$ and Gnd—Update Mode	$C_{VCORE\_UM}$	90		330	nF

Parameter	Symbol	Min	Typ	Max	Units
Input Capacitance Span (Full Scale Values)	$C_0$	2		10	pF
External Reference Capacitance	$C_1$	2		10	pF
External Isolating Capacitance (CC pin to sensor common node) <sup>[c]</sup>	$C_{CC}$			16	pF
I2C Pull-Up Resistor	$R_{PU}$	1	2.2		$k\Omega$
SDA/MISO Load Capacitance	$C_{SDA}$			200	pF

[a] Caution: If buying die, select the proper package to ensure that the maximum junction temperature is not exceeded.

[b] See section 7 for full details on output pad drive strengths.

[c] An external isolating capacitor allows a non-galvanic connection to special differential or external reference sensor types.  $C_{CC}$  could also be used to lower the overall capacitance level to a value that is supported by the ZSSC3122 because it limits the maximum capacitance seen by the ZSSC3122 input to CC even if  $C_0$  and  $C_1$  have higher values. See section 9.2.1.3 for more details.

## 5. Electrical Characteristics

See important table notes at the end of the following table.

Parameter	Symbol	Conditions	Min	Typ	Max	Units
<b>Supply Current</b>						
Update Mode Current (varies with part configuration) <sup>[a]</sup>	$I_{DD}$	Best case settings: 8-bit, 125ms Power Down <sup>[b]</sup>		60	100	$\mu A$
		Worst case settings: 14-bit, 0ms Power Down		750	1100	
Extra Current with PDM Enabled <sup>[b]</sup>	$I_{PDM}$			150		$\mu A$
Sleep Mode Current <sup>[a]</sup>	$I_{SLEEP}$	-20 to 85°C		0.6	1	$\mu A$
		-20 to 125°C		1	3	$\mu A$
<b>Voltage Levels</b>						
Power-On-Reset Level	$V_{POR}$		1.6	1.7	1.75	V
Active Regulated Voltage	$V_{REG}$	Note: Regulated voltage can be measured on the Vcore pin.	2.4	2.55	2.7	V
<b>Capacitance-to-Digital Converter (CDC)</b>						
Resolution	$RES_{CDC}$		8		14	Bits
Excitation Frequency of External Capacitances $C_0$ and $C_1$ (for a system frequency $f_{SYS}$ )	$f_{EXC}$			$f_{SYS}/2$		kHz
Integral Nonlinearity (INL) <sup>[c]</sup>	$INL_{CDC}$	10% to 90% input, 14-bit			0.2	%
Differential Nonlinearity (DNL) <sup>[b]</sup>	$DNL_{CDC}$	10% to 90% input, 14-bit			0.9	LSB



Parameter	Symbol	Conditions	Min	Typ	Max	Units
<b>EEPROM</b>						
Number of Erase/Write Cycles	$n_{WRI\_EEP}$	At 85°C			100k	
Data Retention	$t_{WRI\_EEP}$	At 100°C			10	Year
<b>Temperature Conversion</b>						
Resolution in °C <sup>[b]</sup>	RES <sub>TEMP</sub>	-20 to 125°C, 8-bit mode	0.64	0.96	1.6	°C
		-20 to 125°C, 14-bit mode	0.01	0.015	0.025	
Nonlinearity First Order Fit <sup>[b], [d]</sup>	IN <sub>LDCDC</sub>	-20 to 125°C		±0.5	±1	°C
Nonlinearity Second Order Fit <sup>[b], [e]</sup>	IN <sub>LDCDC</sub>	-20 to 125°C		±0.2	±0.4	°C
Voltage Dependency <sup>[b]</sup>	PSR <sub>TEMP</sub>	$V_{SUPPLY} > V_{REG} + 0.25V$		0.03	0.1	°C/V
		$1.8V \leq V_{SUPPLY} \leq V_{REG} + 0.25V$		1.25	2.25	
<b>PDM Output</b>						
Output Range <sup>[b]</sup>	$V_{PDM\_Range}$		10		90	% $V_{SUPPLY}$
PDM Frequency	$f_{PDM}$			$f_{SYS}/8$		kHz
Filter Settling Time <sup>[b], [f]</sup>	$t_{SETT}$	0% to 90% LP filter 10k $\Omega$ /400nF			9.2	ms
Ripple <sup>[b], [f]</sup>	$V_{RIPP}$	0% to 90% LP filter 10k $\Omega$ /400nF			1.0	mV/V
PDM Additional Error (Including Ratiometricity Error) <sup>[b]</sup>	E <sub>PDM</sub>	-20 to 125°C		0.1	0.5	%
<b>Digital I/O</b>						
Voltage Output Level Low	$V_{OL}$			0	0.2	$V_{SUPPLY}$
Voltage Output Level High	$V_{OH}$		0.8	1		$V_{SUPPLY}$
Voltage Input Level Low	$V_{IL}$			0	0.2	$V_{SUPPLY}$
Voltage Input Level High	$V_{IH}$		0.8	1		$V_{SUPPLY}$
Communication Pin Input Capacitance <sup>[b]</sup>	$C_{IN}$				10	pF
<b>Total System</b>						
Capacitive Tolerance Between Parts <sup>[b]</sup>	$C_{tol}$	All capacitive values in the specification are subject to this variation			±10	%
Trimmed System Frequency	$f_{SYS}$	All timing in this specification is subject to this variation.	1.76	1.85	2.25	MHz
Frequency Variation Over Voltage and Temperature	$f_{var}$	All timing in this specification is subject to this variation.			±10	%
Start-Up-Time <sup>[b], [g], [h]</sup> Power-on (POR) to Data Ready	$t_{STA}$	Fastest and slowest settings	4.25		55	ms
Update Rate (Update Mode) <sup>[b], [g], [h]</sup>	$t_{RESP\_UP}$	Fastest and slowest settings	0.70		165	ms
Response Time (Sleep Mode) <sup>[b], [g], [h]</sup>	$t_{RESP\_SL}$	Fastest and slowest settings	1.25		45	ms

Parameter	Symbol	Conditions	Min	Typ	Max	Units
Parasitic to Gnd Tolerance Including Package Parasitics (Pins C0, CC, and C1) <sup>[b]</sup> .					10	pF
Peak-to-Peak Noise at Output (100 measurements in 14 bit) <sup>[b]</sup>	N <sub>OUT</sub>			5	20	LSB
<b>Accuracy</b>						
Error, -20 to 125°C <sup>[b], [i], [j], [k]</sup>	AE <sub>out</sub>	3V±10%, 3.3V±10%, 5V±10%		±0.25	±0.75	%FSO
		2.5V±10%		±0.50	±1.25	
		2.0V±10%			±2.5	

[a] See section 6 for full details for current consumption in each mode.

[b] Parameter not tested during production but guaranteed by design.

[c] Parameter measured using internal test capacitors (0pF to 7pF in Mult 1).

[d] Assumes optimal calibration points of 0°C and 100°C; see section 8 for more details.

[e] Assumes optimal calibration points of -20°C, 40°C, and 100°C; see section 8 for more details.

[f] See section 10.7 for more details.

[g] See section 10 for more details.

[h] Timing values are for a nominal oscillator; for worst case, ±10% total frequency variation, multiply by 0.9 (min time) or 1.1 (max time).

[i] Accuracy specification includes a 2-point temperature calibration for correcting the internal TC.

[j] Accuracy specification assumes maximum parasitics of 10pF to ground.

[k] Accuracy specification does not include PDM errors; see the PDM Output electrical parameters for additional errors when using PDM.

## 6. Current Consumption Graphs

Part current consumption depends on a number of different factors including voltage, temperature, capacitive input, resolution, and power down time. The best way to calculate the ZSSC3122's power consumption is to measure the current consumption with the actual setup. If measurement is not possible, then the graphs in this section can provide a starting point for estimating the current consumption.

### 6.1 Update Mode Current Consumption

**Figure 6.1 Best Case Settings (Typical Part)**

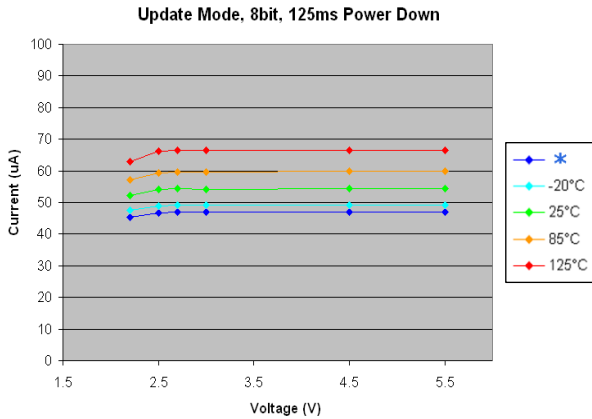

\* Parameter is not within required temperature specifications (-40°C).

**Figure 6.2 Worst Case Settings (Typical Part)**

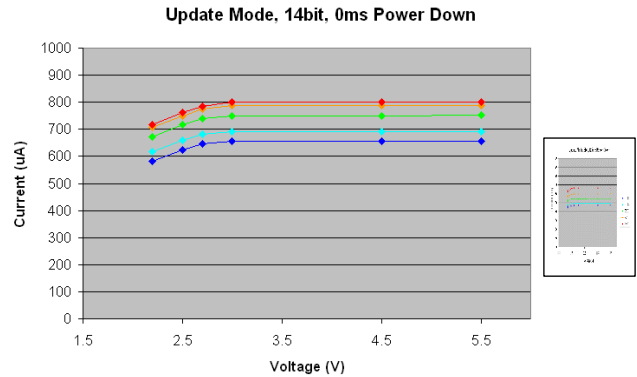

\* Parameter is not within required temperature specifications (-40°C).

### 6.2 Sleep Mode Current Consumption

**Figure 6.3 Typical Current Consumption during Sleep Mode (No Measurements)**

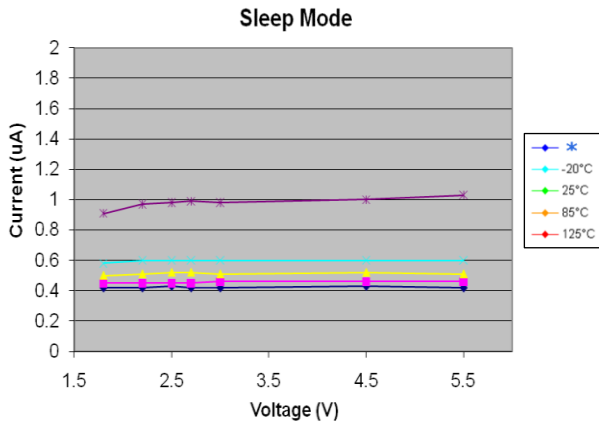

\* Parameter is not within required temperature specifications (-40°C)

## 7. Output Pad Drive Strength

Figure 7.1 Output High Drive Strength Graph

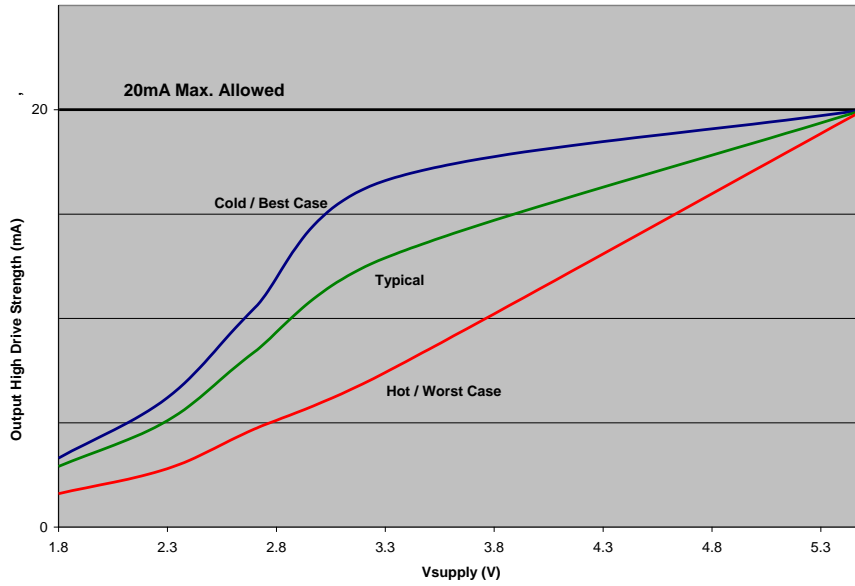
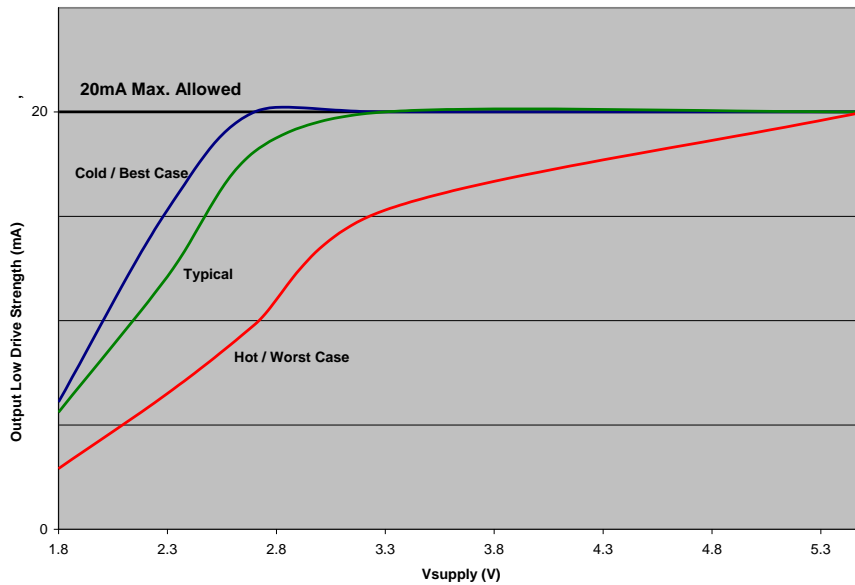

Figure 7.2 Output Low Drive Strength Graph



## 8. Temperature Sensor Nonlinearity

Temperature sensor nonlinearity can vary depending on the type of calibration and the selected calibration points. It is highly recommended that a temperature calibration is done with calibration points at least 20°C apart from each other. Figure 8.1 and Figure 8.2 show the resulting nonlinearity error for the full temperature range (-20°C to 125°C) using the optimal calibration points, 0°C and 100°C for a first-order fit and -20°C, 40°C, and 100°C for a second-order fit.

**Figure 8.1 First Order Fit (Typical Part)**

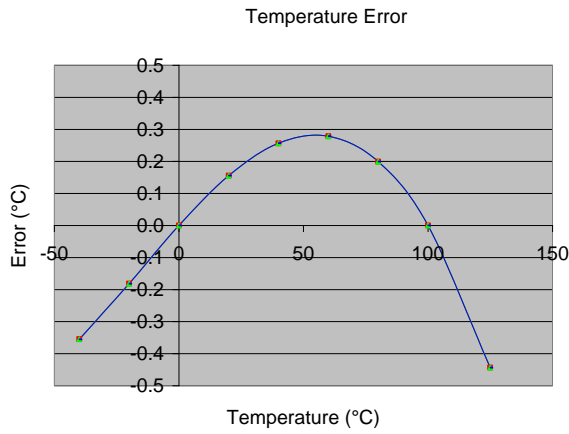

**Figure 8.2 Second Order Fit (Typical Part)**

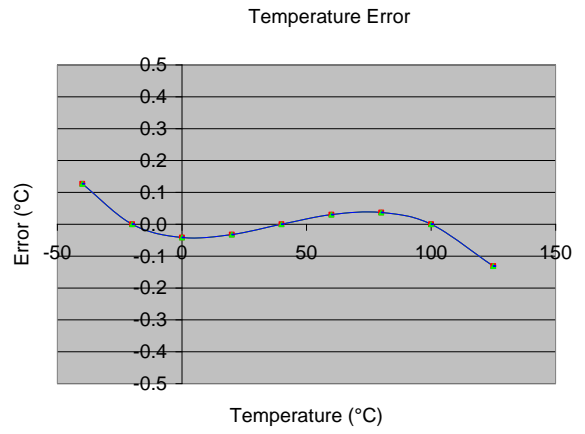

## 9. Circuit Description

### 9.1 Signal Flow and Block Diagram

As seen in Figure 9.1, the ZSSC3122 comprises three main blocks: the analog core, digital core, and output communication. The capacitive input is first sampled by the analog core using a charge-balancing CDC and is adjusted for the appropriate capacitance range using the CDC\_Offset, and CDC\_Reference. The digital core corrects the digital sample with an on-chip digital signal processor (DSP), which uses coefficients stored in EEPROM for precise conditioning. An internal temperature sensor can be used to compensate for temperature effects of the capacitive input. A temperature value can also be calibrated and output as a 14-bit reading.

The corrected capacitance value can be read using four different output types, I2C, SPI, PDM, and alarms. They can all be directly interfaced with a microcontroller, and optional filtering of the PDM output can provide a ratiometric analog output. The alarm pins can also be used to control a variety of analog circuitry.

**Figure 9.1 ZSSC3122 Block Diagram**

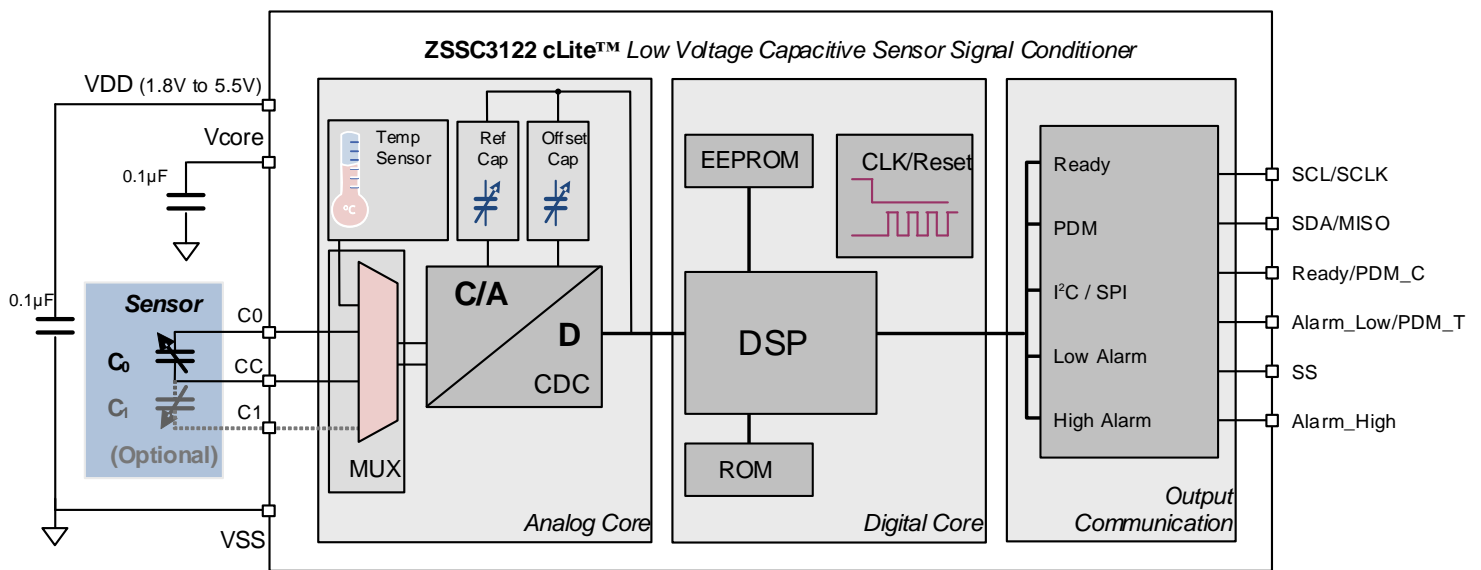

## 9.2 Analog Front-End

### 9.2.1 Capacitance-to-Digital Converter

A 1<sup>st</sup> order charge-balancing capacitance-to-digital converter (CDC) is used to convert the input capacitance to the digital domain. The CDC uses a chopper-stabilized design to decrease any drift over temperature. The CDC interfaces to the sensor capacitor through the input multiplexer that controls whether the measurement is a capacitance or a temperature measurement. The input multiplexer also allows for two sensor capacitance configurations: a single sensor capacitance or a ratio based differential capacitive sensor, two-sensor, capacitor configuration, where the reference capacitor is part of the sensor.

As part of a switched-capacitor network the reference capacitor  $C_1$  is driven by a square wave voltage of the frequency  $f_{EXC}$  (refer to section 5). The sensor capacitance  $C_0$  is not exposed to DC voltages in order to prevent aging effects of some sensor types. The configuration of the CDC is controlled by programming settings in EEPROM word C\_Config. (See Table 12.3 for settings.)

#### 9.2.1.1 Single Ended

In the case of a single-sensor capacitor, the CDC output is proportional to the ratio of the sensor capacitor to an internal reference capacitor ( $C_{REF}$ ). This internal reference capacitor value can be adjusted using the 3-bit trim CDC\_Reference (bit settings in Table 12.3). To optimize the measured end-resolution further, another internal capacitor ( $C_{OFF}$ ) allows the subtraction of a defined offset capacitance using the 3-bit trim CDC\_Offset (bit setting in Table 12.3). Equations (1) to (2) describe the CDC output for a single sensor capacitance measurement. Select the values of CDC\_Offset and CDC\_Reference by using the tables in section 9.2.1.4.

$$Z_{SENSOR} = \frac{(C_0 - C_{OFF})}{C_{REF}} \quad (1)$$

$$Z_{CDC} = 2^{RES} * Z_{SENSOR} \quad (2)$$

With

$$C_{OFF} = 1.44 * CDC\_Offset * 1pF \quad (3)$$

And

$$C_{REF} = 1.44 * CDC\_Reference * 1pF \quad (4)$$

Where:

$Z_{SENSOR}$	Measured sensor ratio, must be in the range [0 to 1]
$C_0$	Input sensor capacitance
$C_{OFF}$	Zero shift of CDC
$C_{REF}$	Reference capacitance
$Z_{CDC}$	Digital raw converted capacitance value
$RES$	Programmable CDC resolution of 8, 10, 12, or 14 bits (bit setting in Table 12.3)
$CDC\_Offset$	CDC offset trim setting (for selection, see section 9.2.1.4 and for bit setting, see Table 12.3)
$CDC\_Reference$	CDC reference setting (for selection, see section 9.2.1.4 and for bit setting, see Table 12.3)

### 9.2.1.2 Single Ended with External Reference

Some sensors include an external reference capacitor as part of the sensor construction. If the external reference capacitance ( $C_1$ ) is constant or increases with increasing input sensor capacitance ( $C_0$ ), then use CDC output equations (5) to (7). In this case, the CDC\_Reference should be set to zero (see bit setting in Table 12.3).

$$Z_{SENSOR} = \frac{(C_0 - C_{OFF})}{C_1} \quad (5)$$

$$Z_{CDC} = 2^{RES} * Z_{SENSOR} \quad (6)$$

$$C_{OFF} = 1.44 * CDC\_Offset * 1pF \quad (7)$$

Where

$Z_{SENSOR}$	Measured sensor ratio; must be in the range [0 to 1]
$C_0$	Input sensor capacitance
$C_{OFF}$	Zero shift of CDC
$C_1$	External reference capacitance
$Z_{CDC}$	Digital raw converted capacitance value
$RES$	Programmable CDC resolution of 8, 10, 12, or 14 bits (see bit setting in Table 12.3)
$CDC\_Offset$	CDC offset trim setting (for selection, see section 9.2.1.4 and for bit setting see Table 12.3)

### 9.2.1.3 Differential

A differential capacitive sensor includes two capacitors  $C_0$  and  $C_1$  that are captured as a ratio. The differential sensor is built so that the sensor input capacitance  $C_0$  increases while the external reference capacitance  $C_1$  decreases over the input signal range, but the total sum always remains constant. Equations (8) and (9) describe the CDC output for a differential sensor capacitance measurement. The CDC\_Reference and CDC\_Offset capacitor trim bits must be set to zero, and the Differential bit must be set to one. (See Table 12.3 for bit numbers and settings.) The sum of  $C_0$  and  $C_1$  must not exceed the maximum input range of 10pF, except when CC is used as a decoupling capacitor.

In differential mode, special sensor types can allow a non-galvanic connection with an external isolating capacitor  $C_{CC}$  between the sensor and the CC pin to avoid wear caused by mechanical moving parts.

$$Z_{SENSOR} = \frac{C_0}{(C_0 + C_1)} \quad (8)$$

$$Z_{CDC} = 2^{RES} * Z_{SENSOR} \quad (9)$$

Where

$Z_{SENSOR}$	Measured sensor ratio, must be in the range [0 to 1]
$C_0$	Input sensor capacitance (moves in the opposite direction of $C_1$ )
$C_1$	External reference capacitance (moves in the opposite direction of $C_0$ )
$Z_{CDC}$	Digital raw converted capacitance value
$RES$	Programmable CDC resolution of 8, 10, 12, or 14 bits (bit setting in Table 12.3)



**9.2.1.4 Capacitive Range Selection**

For singled ended sensors, use Table 9.1 as guidance to select appropriate values for the CDC ( $C_{OFF}$ ) and ( $C_{REF}$ ) for a particular capacitance input range. The CDC\_Offset and CDC\_Reference bits are found in EEPROM word C\_Config. (See Table 12.3 for bit numbers). Using the settings given in Table 9.1, the CDC input range can be adjusted to optimize the coverage of the sensor signal and offset values to give the maximum sensor span that can be processed without losing resolution. Choose a range by fitting the input sensor span within the narrowest range in the table, but note that these tables are only approximate, so the range should be chosen by experimenting with the actual setup. Also note that since internal capacitance values can vary over process (see specification parameter  $C_{tol}$  in section 5), the minimum and maximum sensor span should be at least  $\pm 10\%$  within the minimum and maximum of the chosen range respectively.

**Note:** A  $C_{REF}$  setting of 0 (marked with \* in the following tables) is only supported with an external reference capacitor (C1) for single-ended sensors. C1 capacitance values should be within the defined range.

**Table 9.1 Selection Settings for  $C_{REF}$  and  $C_{OFF}$**

Note: Capacitance ranges are nominal values.

Note: Production-related tolerances can change the nominal capacitance values by  $\pm 10\%$ .

		CDC_Reference															
3-bit set		0*		1		2		3		4		5		6		7	
CDC_Offset	0	0.0	C1	0.0	1.4	0.0	2.9	0.0	4.3	0.0	5.8	0.0	7.2	0.0	8.6	0.0	10.1
	1	1.4	C1	1.4	2.9	1.4	4.3	1.4	5.8	1.4	7.2	1.4	8.6	1.4	10.1	1.4	11.5
	2	2.9	C1	2.9	4.3	2.9	5.8	2.9	7.2	2.9	8.6	2.9	10.1	2.9	11.5		
	3	4.3	C1	4.3	5.8	4.3	7.2	4.3	8.6	4.3	10.1	4.3	11.5				
	4	5.8	C1	5.8	7.2	5.8	8.6	5.8	10.1	5.8	11.5						
	5	7.2	C1	7.2	8.6	7.2	10.1	7.2	11.5								
	6	8.6	C1	8.6	10.1	8.6	11.5										
	7	10.1	C1	10.1	11.5												
		not recommended				PROHIBITED											

## 9.2.2 Temperature Measurement

The temperature signal comes from an internal PTAT (proportional to absolute temperature) circuit that is a measure of the die temperature. The PTAT ( $V_{PTAT}$ ) voltage is used in the CDC to charge an internal capacitor ( $C_T$ ), while the bandgap voltage ( $V_{BG}$ ) is used to charge the offset and the reference trimmable capacitors. The CDC temperature output ( $Z_{TEMP}$ ) is defined by equations (10) to (13):

$$Z_{TEMP} = 2^{RES} * \frac{(V_{PTAT} / V_{BG}) * C_T - C_{TOFF}}{C_{TREF}} \quad (10)$$

With

$$C_T = 1.44 * Temp\_Trim * 1pF \quad (11)$$

With

$$C_{TOFF} = 1.44 * CDC\_Offset * 1pF \quad (12)$$

And

$$C_{TREF} = 1.44 * CDC\_Reference * 1pF \quad (13)$$

Where

$Z_{TEMP}$	Measured internal temperature
$RES$	Programmable CDC resolution of 8, 10, 12, or 14 bits (bit setting in Table 12.4)
$V_{PTAT}$	Internal PTAT voltage
$V_{BG}$	Internal bandgap voltage
$C_T$	Temperature measurement capacitor
$C_{TOFF}$	Temperature CDC zero shift
$C_{TREF}$	Temperature reference capacitance
$Temp\_Trim$	Temperature trim setting (bit setting in Table 12.4)
$CDC\_Offset$	CDC offset trim setting (bit setting in Table 12.4)
$CDC\_Reference$	CDC reference setting (bit setting in Table 12.4)

**Note:** The factory settings for  $Temp\_Trim$ ,  $CDC\_Offset$ , and  $CDC\_Reference$  are optimized for the full temperature range of -20°C to 125°C guaranteeing a minimum effective resolution of 13 bits when 14 bits of resolution is selected. Unless a different temperature range is needed, it is strongly recommended that these settings not be changed.

### **9.3 Digital Core**

The digital core provides control logic for the analog front-end, performs input signal conditioning, and handles external communication. A digital signal processor (DSP) is used for conditioning and correcting the converted sensor and temperature inputs. The DSP can correct for up to a two-region piece-wise nonlinear sensor input, and up to a second-order nonlinear temperature input. Alternatively a third-order correction of the sensor input for one region and up to a second-order nonlinear temperature input can be selected. Refer to section 13 for details on the signal conditioning and correction math. The analog front-end configuration and correction coefficients for both the capacitive sensor and the temperature sensor are stored in an on-chip EEPROM (see section 12).

Four different types of outputs are available: I2C, SPI, PDM, and the Alarms. These output modes are used in combination with the two measurement modes: Update Mode and Sleep Mode. For a full description of normal operation in each mode, refer to section 10.

The ZSSC3122 has an internal 1.85MHz temperature-compensated oscillator that provides the time base for all operations. When VDD exceeds the POR level, the reset signal de-asserts and the clock generator starts. See section 10.1 for the subsequent power-up sequence. The exact clock frequency influences the measurement cycle time (see the frequency variation spec in section 5). To minimize the oscillator error as the VDD voltage changes, an on-chip regulator supplies the oscillator block.

## 10. Normal Operation Mode

Figure 10.1 gives a general overview of ZSSC3122 operation. Details of operation, including the power-up sequence, measurement modes, output modes, diagnostics, and commands, are given in the subsequent sections.

**Figure 10.1 General Operation**

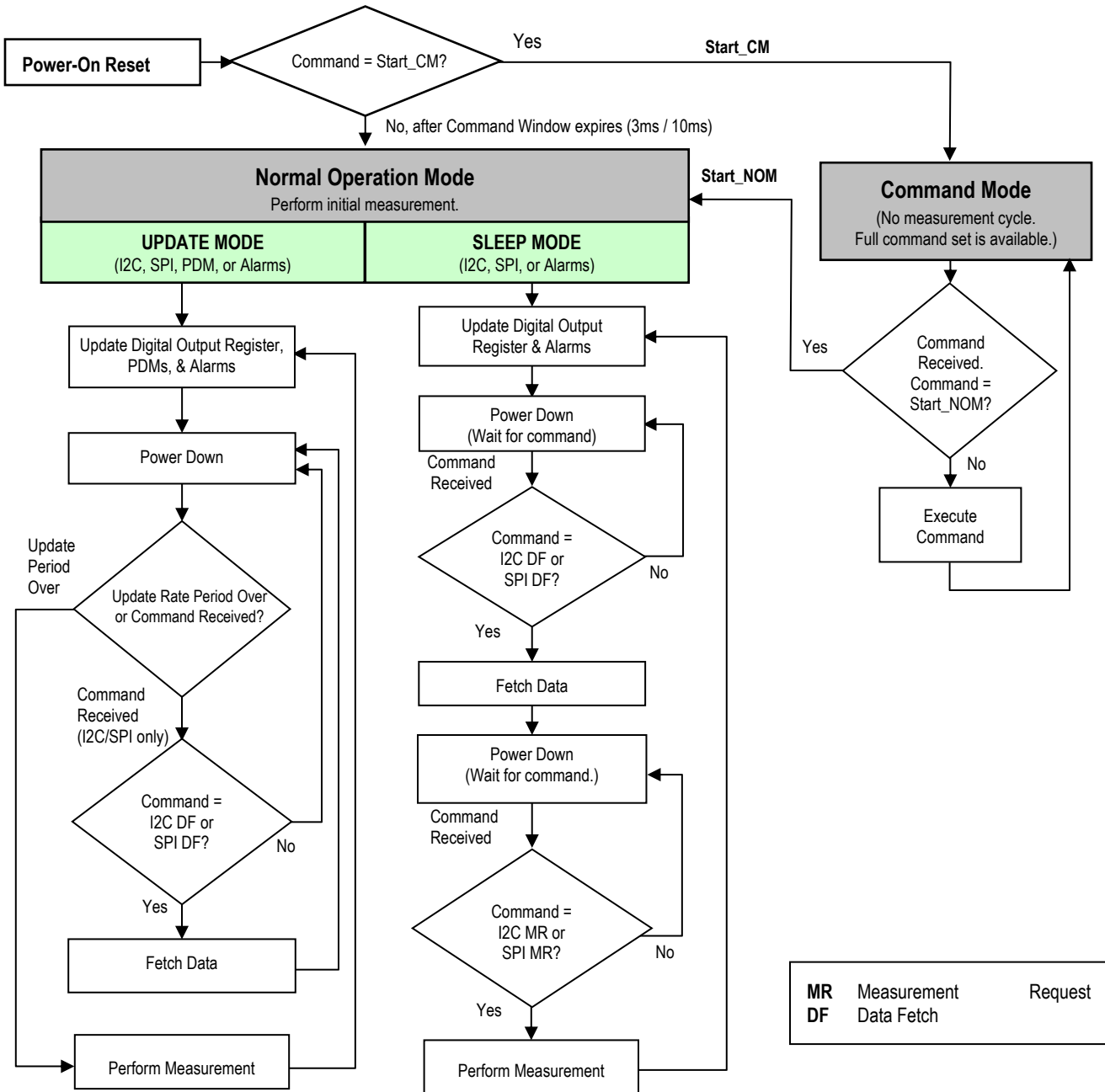

## 10.1 Power-On Sequence

Figure 10.2 shows the power-on sequence of the ZSSC3122. On system power-on reset (POR), the ZSSC3122 wakes as an I2C device regardless of the output protocol programmed in EEPROM. After power-on reset, the ZSSC3122 enters the command window. It then waits for a Start\_CM command for 3ms if the Fast\_Startup EEPROM bit is set or 10ms otherwise (see Table 12.5). If the ZSSC3122 receives the Start\_CM command during the command window, it enters and remains in Command Mode. Command Mode is primarily used in the calibration environment. See section 11 for details on Command Mode.

If during the power-on sequence, the command window expires without receiving a Start\_CM or if the part receives a Start\_NOM command in Command Mode, the device will immediately assume its programmed output mode and will perform one complete measurement cycle. Timing for the initial measurement is described in section 10.2. At the end of the capacitance DSP calculation, the first data is written to the output register. Beyond this point, conversions are performed according to the programmed measurement mode settings (see section 10.3).

**Figure 10.2 Power-On Sequence with Fast Startup Bit Set in EEPROM**

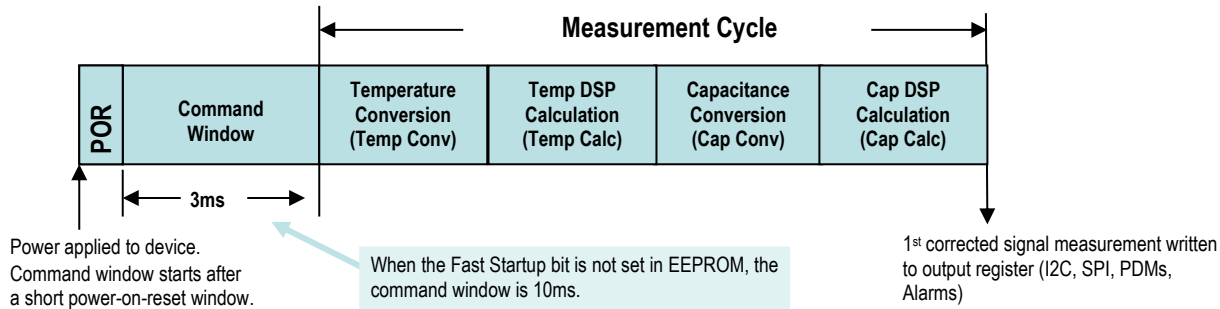

**Note:** See section 10.2 for timing of the measurement cycle. Timing values shown are typical; for the worst case values, multiply by 1.1 (nominal frequency  $\pm 10\%$ ).

## 10.2 Measurement Cycle

Figure 10.3 shows a typical measurement cycle. At the start of a measurement, there is a small wakeup period and then an internal temperature conversion/temperature DSP calculation is performed followed by a capacitance conversion/capacitance DSP calculation. The length of these conversions depends on the setting of the Resolution bits (see Table 10.1). The resolution can be found in EEPROM words C\_Config and T\_Config (see Table 12.3 and Table 12.4 for bit numbers). Each conversion cycle is followed by a DSP calculation, which uses the programmed calibration coefficients to calculate corrected temperature and capacitance measurements. In Update Mode, a temperature conversion is not performed every measurement cycle because it is considered a slower moving quantity. In this case, the measurement cycle timing is the same as Figure 10.3 without the temperature conversion/ temperature DSP calculation (see section 10.3.1 for more information).

**Figure 10.3 Measurement Cycle Timing**

Note: All time values shown are typical; for the worst case values, multiply by 1.1 (nominal frequency ±10%).

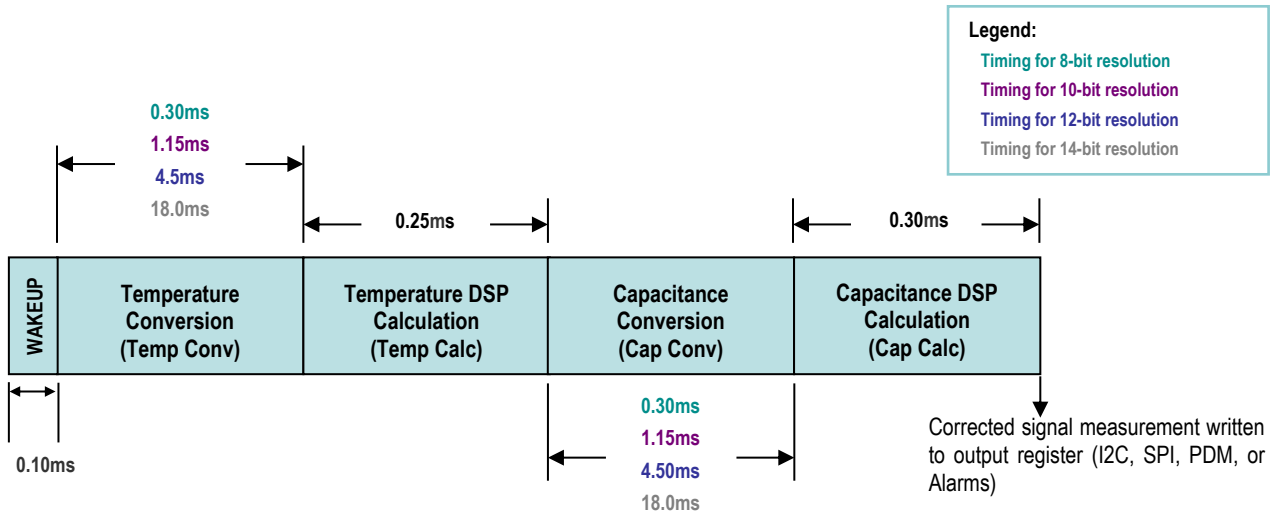

**Table 10.1 CDC Resolution and Conversion Times**

EEPROM Encoding	CDC Resolution (Bits)	Temperature Conversion Time (ms) [a]	Capacitance Conversion Time (ms) [a]
00 <sub>BIN</sub>	8	0.30	0.30
01 <sub>BIN</sub>	10	1.15	1.15
10 <sub>BIN</sub>	12	4.50	4.50
11 <sub>BIN</sub>	14	18.0	18.0

[a] All time values shown are typical; for the worst case values, multiply by 1.1 (nominal frequency ±10%).

## 10.3 Measurement Modes

The ZSSC3122 can be programmed to operate in either Sleep Mode or Update Mode. The measurement mode is selected with the Measurement\_Mode bit in the ZMDI\_Config EEPROM word (see Table 12.2). In Update Mode, measurements are taken at a fixed, selectable rate (see section 10.3.1). In Sleep Mode, the part waits for commands from the master before taking measurements (see section 10.3.2).

Figure 10.1 shows the differences in operation between the two measurement modes.

### 10.3.1 Update Mode

In Update Mode, the digital core will perform conversions at an update rate selected with the Update\_Rate bits in the ZMDI\_Config EEPROM word (see Table 12.2). Table 10.2 shows the power-down periods between conversions for the four Update\_Rate settings. The benefit of slower update rates is power savings. Update Mode is compatible with all the different output modes; I2C, SPI, PDMs, and the Alarms. As shown in Figure 10.4, at the completion of a measurement cycle, the digital output register, PDMs, and/or Alarms will be updated before powering down. When the power-down period expires, the ZSSC3122 will wake up and perform another measurement cycle. If the part is programmed for the fastest update rate, there is no power down period, and measurements happen continuously.

**Table 10.2 Update Rate Settings**

Note: All time values shown are typical; for the worst case values, multiply by 1.1 (nominal frequency ±10%).

Update_Rate	Power Down Period (ms)
00 <sub>BIN</sub>	0
01 <sub>BIN</sub>	5
10 <sub>BIN</sub>	25
11 <sub>BIN</sub>	125

**Figure 10.4 Measurement Sequence in Update Mode**

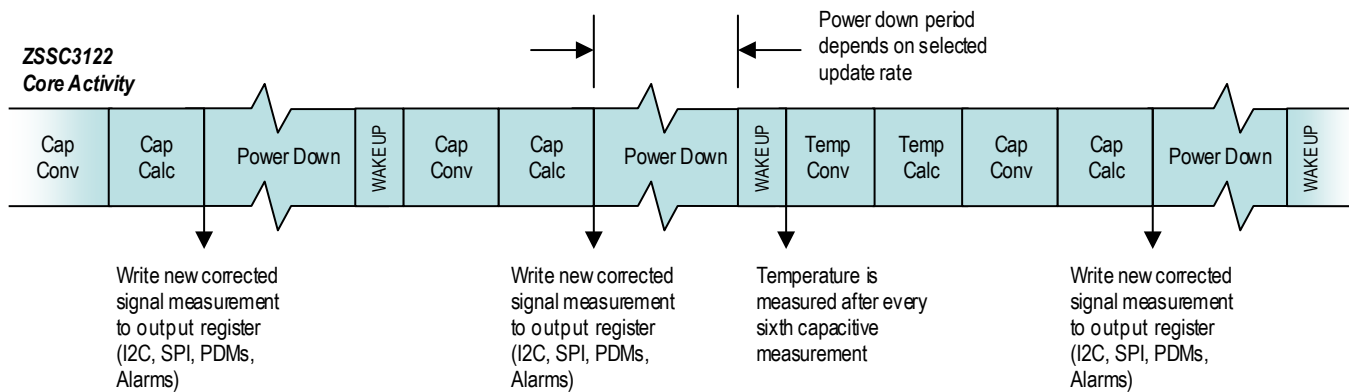

**Note:** See section 10.2 for measurement cycle timing.

To calculate the total time between capacitive measurements in Update Mode, add the measurement cycle timing from section 10.2 and the power down timing from Table 10.2. Typical settings might be a capacitance measurement with a resolution of 12-bits.

In this example, the time between measurements = (4.5ms + 0.1ms + 0.3ms) + (power down period). Table 10.3 shows the time between measurements for the different update rate settings and bit resolutions.

Temperature measurements are performed every six capacitive measurements. The actual frequency of temperature conversions varies with the update rate and AFE configuration settings. As shown in Figure 10.4, when a temperature measurement is performed, a capacitance measurement occurs immediately after; as a result, the total measurement cycle time is increased by the length of the temperature conversion/temperature DSP calculation.

To calculate the total time between temperature measurements in Update Mode, multiply the time between capacitive measurements as calculated in the above text by six (there are six capacitive measurements to every temperature measurement) and then add the temperature conversion time/temperature DSP calculation time from Table 10.1. For example, a temperature measurement with a resolution of 12-bits has a conversion time/DSP calculation time of 4.5ms + 0.25ms (from Table 10.1). Continuing with the above example (12-bit capacitive measurement), the time between temperature measurements is (capacitance update time \* 6) + 4.75ms.

**Table 10.3 Time Periods between Capacitance Measurements and Temperature Measurements for Different Resolution and Update Rates**

CDC Resolution (Bits)	Total Time between Capacitance Measurements (ms)				Total Time between Temperature Measurements (ms)			
	Update Rate 00 <sub>BIN</sub>	Update Rate 01 <sub>BIN</sub>	Update Rate 10 <sub>BIN</sub>	Update Rate 11 <sub>BIN</sub>	Update Rate 00 <sub>BIN</sub>	Update Rate 01 <sub>BIN</sub>	Update Rate 10 <sub>BIN</sub>	Update Rate 11 <sub>BIN</sub>
8	0.70	5.70	25.70	125.70	4.75	34.75	154.75	754.75
10	1.55	6.55	26.55	126.55	10.70	40.70	160.70	760.70
12	4.90	9.90	29.90	129.90	34.15	64.15	184.15	784.15
14	18.40	23.40	43.40	143.40	128.65	158.65	278.65	878.65

**10.3.1.1 Data Fetch in Update Mode**

In Update Mode, I2C and SPI are used to fetch data from the digital output register using a Data Fetch (DF) command (see section 10.6.3).

Detecting when data is ready to be fetched can be handled either by polling or by monitoring the Ready pin (see section 10.6.6 for details on the Ready pin). The status bits of a DF tell whether or not the data is valid or stale (see section 10.4 regarding the status bits). As shown in Figure 10.5 after a measurement cycle is complete, valid data can be fetched. If the next data fetch is performed too early, the data will be the same as the previous fetch with stale status bits. As shown in Figure 10.5, a rise on the Ready pin can also be used to tell when valid data is ready to be fetched.

**Figure 10.5 I2C and SPI Data Fetching in Update Mode**

Note: See section 10.2 for timing of measurements.

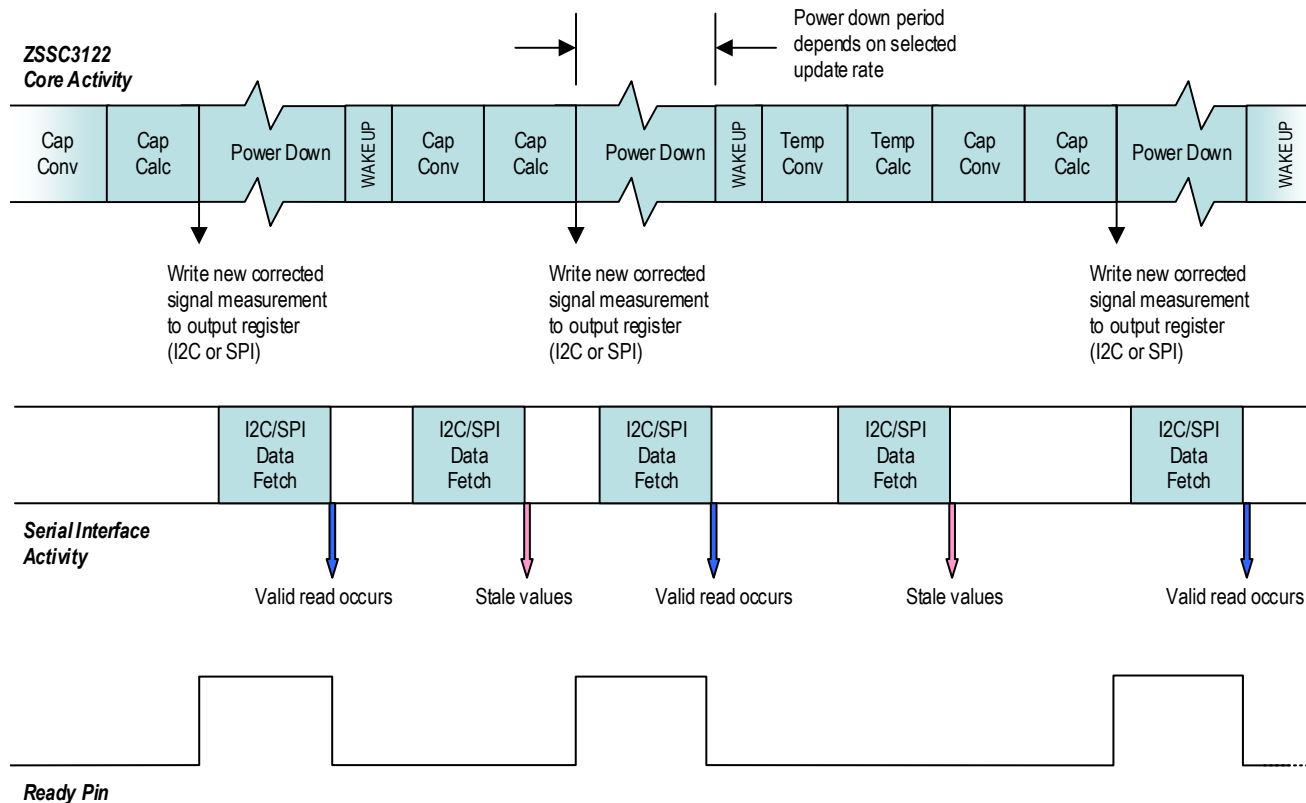



### 10.3.2 Sleep Mode

In Sleep Mode, the digital core will only perform conversions when the ZSSC3122 receives a Measurement Request command (MR); otherwise, the ZSSC3122 is always powered down. Measurement Request commands can only be sent using I2C or SPI, so PDM is not available. The Alarms can be used in Sleep Mode but only in combination with I2C or SPI. More details about MR commands in Sleep Mode operation can be found in section 10.3.2.1.

**Note:** Sleep Mode power consumption is significantly lower than Update Mode power consumption (see section 5 for exact values).

Figure 10.6 shows the measurement and communication sequence for Sleep Mode. The master sends an MR command to wake the ZSSC3122 from power down. After the ZSSC3122 wakes up, a measurement cycle is performed consisting of both a temperature and a capacitance conversion followed by the DSP correction calculations.

At the end of a measurement cycle, the digital output register and Alarms will be updated before powering down. An I2C or SPI data fetch (DF) is performed during the power-down period to fetch the data from the output register. In I2C the user can send another MR to start a new measurement cycle without fetching the previous data, but in SPI, a DF must be done before another MR can be sent. After the data has been fetched, the ZSSC3122 remains powered down until the master sends an MR command. The timing for measurements is given in section 10.2.

**Figure 10.6 Measurement Sequence in Sleep Mode (Only I2C, SPI, or Alarms)**

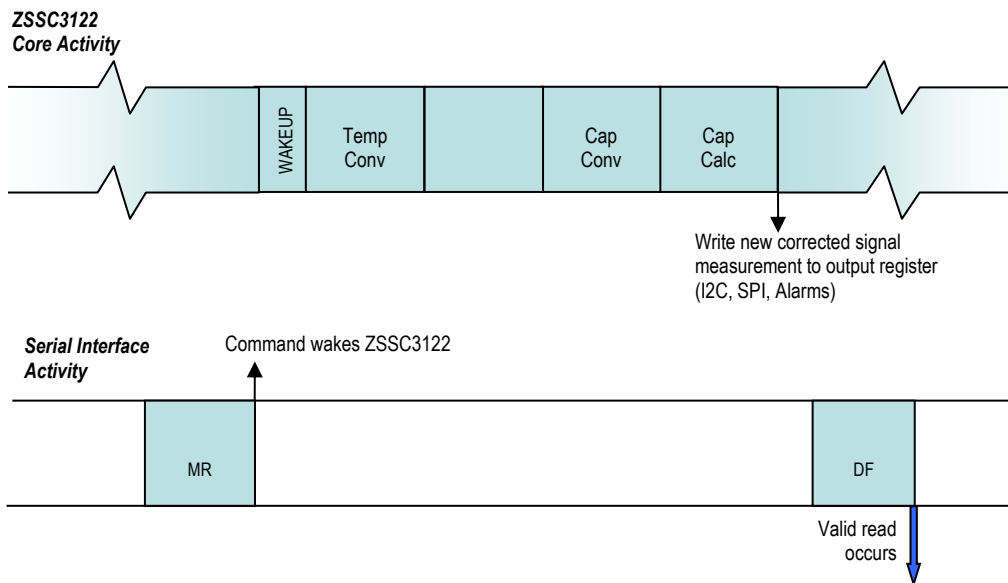

**Note:** See section 10.2 for timing of measurements.

#### 10.3.2.1 Data Fetch in Sleep Mode

In Sleep Mode, I2C and SPI are used to request a measurement with a MR command and to fetch data from the digital output register using a Data Fetch (DF) command (see section 10.6.3).

As shown in Figure 10.7, after a measurement cycle is complete, valid data can be fetched. The preferred method of detecting valid data is to wait for a rise on the Ready pin (see section 10.6.6 for details on the Ready pin). If the Ready pin is not available, the user must wait for the measurements to complete before performing the DF (see section 10.2 for measurement timing). The status bits of the DF can be used to tell whether the data is valid or stale (see section 10.4 regarding the status bits), but polling for the result must not be done before the time required for conversion has elapsed.

**Figure 10.7 I2C and SPI Data Fetching in Sleep Mode**

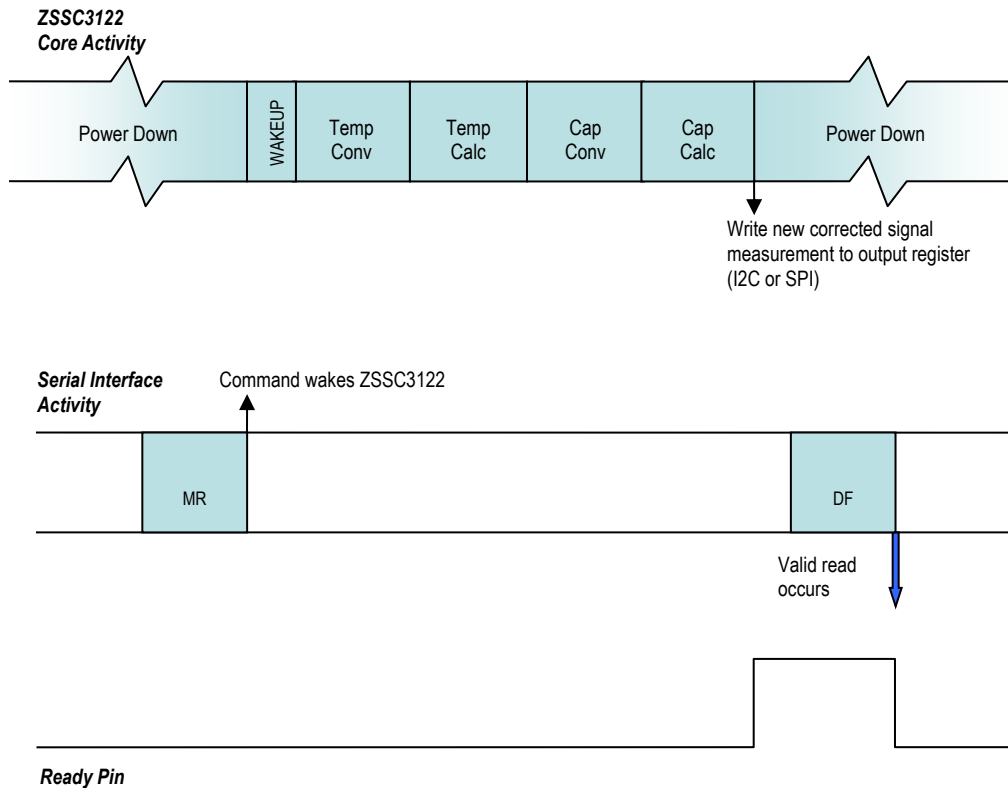

**Note:** See section 10.2 for timing of measurements.

### 10.4 Status and Diagnostics

Status bits (the two MSBs of the fetched high data byte, see Table 10.4) are provided in I2C and SPI but not in PDM. The status bits are used to indicate the current state of the fetched data. Diagnostic detection is available in I2C, SPI, and PDM. In I2C and SPI diagnostics are reported as a saturated high capacitance and temperature output (see Table 10.5). In PDM, diagnostics are reported as a railed high output level for both PDM\_C (capacitive PDM) and PDM\_T (temperature PDM). If a diagnostic value is reported then one or more of the errors that are shown in Table 10.6 occurred in normal operation.

Configuration EEPROM diagnostics are detected at initial power-up of the ZSSC3122 or a wakeup in Sleep Mode and are permanent diagnostics. All other diagnostics are detected during a measurement cycle and reported in the subsequent data fetch for I2C or SPI or output register update for PDM.

**Table 10.4 Status Table**

Status Bits (I2C or SPI)	PDM Output	Definition
00 <sub>BIN</sub>	Clipped normal output	Valid data: Data that has not been fetched since the last measurement cycle.
01 <sub>BIN</sub>	Not applicable	Stale data: Data that has already been fetched since the last measurement cycle. <b>Note:</b> If a data fetch is performed before or during the first measurement after power-on reset, then Stale will be returned, but this data is actually invalid since the first measurement has not been completed.
10 <sub>BIN</sub>	Not applicable	Command Mode: The ZSSC3122 is in Command Mode.
11 <sub>BIN</sub>	Not used	Not used

**Table 10.5 Diagnostic Detection**

I2C or SPI Output	PDM Output	Definition
Saturated output 3FFF <sub>HEX</sub>	High output (railed) level	A diagnostic has occurred in normal operation (see Table 10.6).

**Table 10.6 Normal Operation Diagnostic Table**

Diagnostic	Type	Definition
Configuration Error	Permanent	An EEPROM or RAM Parity Error occurred in the initial loading of the configuration registers.
RAM Parity Error	Transient	A RAM Parity Error occurred during a microcontroller instruction in the last measurement cycle.
EEPROM Error	Transient	A DED EEPROM error occurred in the last measurement cycle (see section 10.4.1).
Math Warning	Transient	An internal math overflow has occurred in the last measurement cycle and the output might be invalid.

#### 10.4.1 EEPROM Error Detection and Correction

The contents of the EEPROM are protected via error checking and correction (ECC). Each of the 32 16-bit words contains 6 parity bits enabling single-bit error correction and double-bit error detection (SEC and DED) per word. In Command Mode both SEC and DED errors are reported in the response byte (see section 11.3). If the fetched EEPROM data has a DED error, then the fetched data will be incorrect; however, if a SEC error was reported then the fetched data has been corrected, and it is the user's choice to write the data back to attempt to correct the error. During Normal Operation Mode, a diagnostic will be flagged on any DED error, but an SEC error will be automatically corrected and not flagged as a diagnostic.

#### 10.4.2 Alarm Diagnostics

The alarm outputs do not report diagnostics. If diagnostics are needed with alarm outputs, then either digital or PDM outputs must also be used.

## 10.5 Output Modes

The ZSSC3122 has four different output modes as shown in Table 10.7. See the corresponding reference sections for specifics on each mode.

**Table 10.7 Output Modes**

Output Mode	Reference Sections
I2C	Section 10.6
Read only SPI	
PDM	Section 10.7
Alarms	Section 10.8

As described in the pin configuration in section 2, the output communication modes share pins. The Output\_Selection bits in EEPROM word ZMDI\_Config (see section 12.1) select which of these outputs will be enabled. Table 10.8 shows the pin configuration for the different output selections.

**Table 10.8 Pin Assignment for Output Selections**

	Output Selection			
	I2C (001 <sub>BIN</sub> )	SPI (011 <sub>BIN</sub> )	PDM_C (100 <sub>BIN</sub> )	PDM_C+T (110 <sub>BIN</sub> )
Pin 8	Alarm_Low	Alarm_Low	Alarm_Low	PDM_T
Pin 9	Alarm_High	Alarm_High	Alarm_High	Alarm_High
Pin 10	Ready	Ready	PDM_C	PDM_C
Pin 12	SDA	MISO	SDA	SDA
Pin 13	SCL	SCLK	SCL	SCL
Pin 14	No input	SS	No input	No Input

## 10.6 I2C and SPI

Two wire I2C and three-wire read-only SPI are available for fetching data from the ZSSC3122. I2C is used to send calibration commands to the ZSSC3122. To choose I2C or SPI, set the corresponding Output\_Selection Bits in EEPROM word ZMDI\_Config.

### 10.6.1 I2C Features and Timing

The ZSSC3122 uses an I2C-compatible communication protocol<sup>1</sup> with support for 100kHz and 400kHz bit rates. The ZSSC3122 I2C slave address (00<sub>HEX</sub> to 7F<sub>HEX</sub>) is selected by the Device\_ID bits in the Cust\_Config EEPROM word (see Table 12.5 for bit assignments). The device will respond only to this address if the communication lock is set by programming 011<sub>BIN</sub> in the Comm\_lock bits in the ZMDI\_Config EEPROM word (see Table 12.2 for bit assignments); otherwise, the device will respond to all I2C addresses. The factory setting for the I2C slave address is 28<sub>HEX</sub> with Comm\_lock set. See Figure 10.8 for the I2C timing diagram and Table 10.9 for definitions of the parameters shown in the diagram.

<sup>1</sup> For details, refer to <http://www.standards.nxp.com/literature/books/i2c/pdf/i2c.bus.specification.pdf> or other websites for this specification.

**Figure 10.8 I2C Timing Diagram**

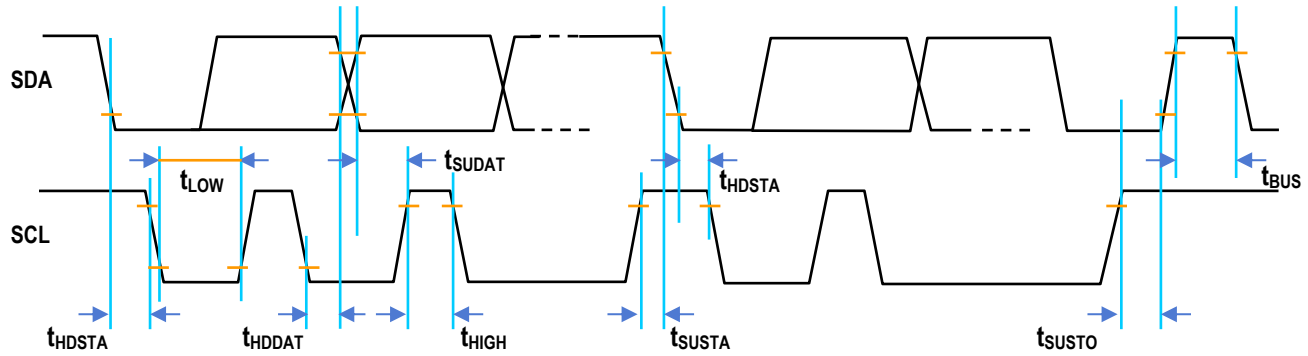

**Table 10.9 I2C Parameters**

Parameter	Symbol	Min	Typ	Max	Units
SCL clock frequency <sup>[a]</sup>	$f_{SCL}$	20		400	kHz
Start condition hold time relative to SCL edge	$t_{HDSTA}$	0.1			$\mu s$
Minimum SCL clock low width <sup>[b]</sup>	$t_{LOW}$	0.6			$\mu s$
Minimum SCL clock high width <sup>[b]</sup>	$t_{HIGH}$	0.6			$\mu s$
Start condition setup time relative to SCL edge	$t_{SUSTA}$	0.1			$\mu s$
Data hold time on SDA relative to SCL edge	$t_{HDDAT}$	0		0.5	$\mu s$
Data setup time on SDA relative to SCL edge	$t_{SUDAT}$	0.1			$\mu s$
Stop condition setup time on SCL	$t_{SUSTO}$	0.1			$\mu s$
Bus free time between stop condition and start condition	$t_{BUS}$	1			$\mu s$

[a] The minimum frequency of 20kHz applies to calibration/test only (required to meet Command Window timing). There is no minimum for NOM.

[b] Combined low and high widths must equal or exceed minimum SCL period.

### 10.6.2 SPI Features and Timing

SPI is available only as half duplex (read-only from the ZSSC3122). SPI speeds of up to 800kHz can be supported. The SPI interface can be programmed to allow the master to sample MISO on the falling-edge or rising-edge of SCLK via the SPI\_Phase bit in EEPROM word Cust\_Config (see Table 12.5 for bit assignments). See Figure 10.9 for the SPI timing diagram and Table 10.10 for definitions of the parameters shown in the timing diagram.

**Figure 10.9 SPI Timing Diagram**

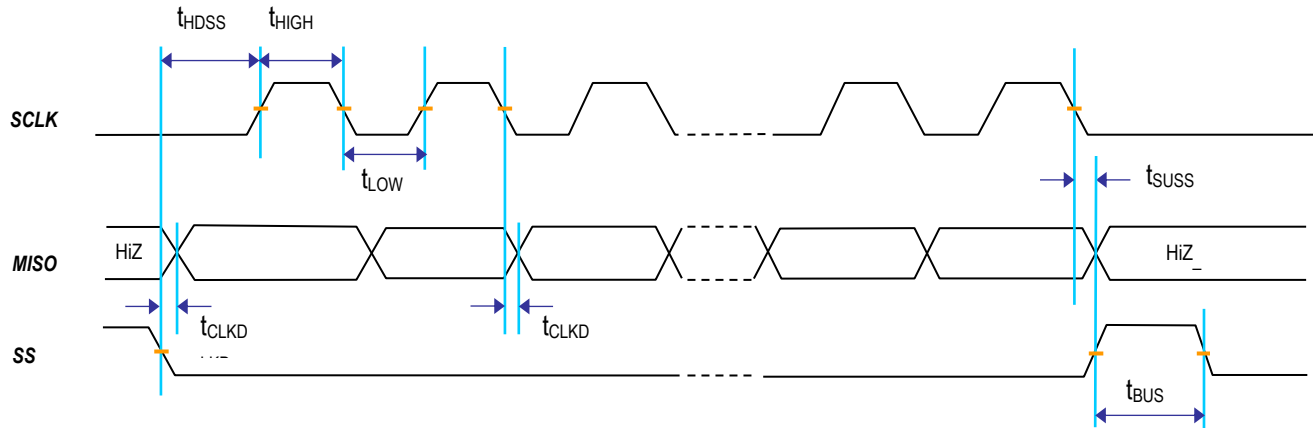

**Table 10.10 SPI Parameters**

Parameter	Symbol	Min	Typ	Max	Units
SCLK clock frequency	$f_{SCL}$	50		800	kHz
SS drop to first clock edge	$t_{HDSS}$	2.5			$\mu s$
Minimum SCLK clock low width <sup>[a]</sup>	$t_{LOW}$	0.6			$\mu s$
Minimum SCLK clock high width <sup>[a]</sup>	$t_{HIGH}$	0.6			$\mu s$
Clock edge to data transition	$t_{CLKD}$	0		0.5	$\mu s$
Rise of SS relative to last clock edge	$t_{SUSS}$	0.1			$\mu s$
Bus free time between rise and fall of SS	$t_{BUS}$	2			$\mu s$

[a] Combined low and high widths must equal or exceed minimum SCLK period.

### 10.6.3 I2C and SPI Commands

As detailed in Table 10.11, there are three types of commands that allow the user to interface with the ZSSC3122 in the I2C or SPI modes.

**Table 10.11 I2C and SPI Command Types**

Type	Description	Communication Supported	Reference Sections
Data Fetch (DF)	Used to fetch data in any digital mode	I2C and SPI	Section 10.6.4
Measurement Request (MR)	Used to start measurements in Sleep Mode	I2C and SPI	Section 10.6.5
Calibration Commands	Used in Command Mode during the calibration process	I2C Only	Section 11.2

### 10.6.4 Data Fetch (DF)

The Data Fetch (DF) command is used to fetch data in any digital output mode. With the start of communication (for I2C after reading the slave address; for SPI at the falling edge of SS) the entire output packet will be loaded in a serial output register. The register will be updated after the communication is finished. The output is always scaled to 14 bits independent of the programmed resolution. The ordering of the bits is big-endian.

#### 10.6.4.1 I2C Data Fetch

An I2C Data Fetch command starts with the 7-bit slave address and the 8<sup>th</sup> bit = 1 (READ). The ZSSC3122 as the slave sends an acknowledge (ACK) indicating success. The number of data bytes returned by the ZSSC3122 is determined by when the master sends the NACK and stop condition. Figure 10.10 shows examples of fetching two and three bytes respectively. The full 14 bits of capacitive data are fetched in the first two bytes. The MSBs of the first byte are the status bits.

If temperature data is needed, additional temperature bytes can be fetched. In Figure 10.10, the three-byte data fetch returns 1 byte of temperature data (8-bit accuracy) after the capacitive data. A fourth byte can be fetched where the six MSBs of the fetched byte are the six LSBs of a 14-bit temperature measurement. The last two bits of the fourth byte are undetermined and should be masked off in the application.

**Figure 10.10 I2C Measurement Packet Reads**

*I2C DF – 2 Bytes: Slave returns only capacitance data to the master in 2 bytes*

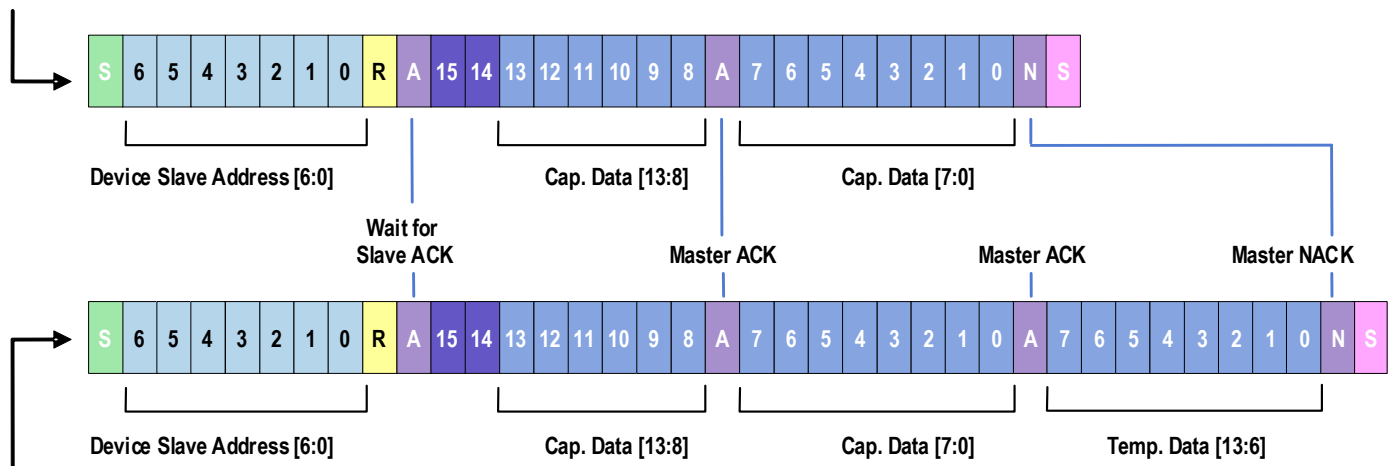

*I2C DF – 3 Bytes: Slave returns 2 capacitance data bytes & temperature high byte (T[13:6]) to the master*

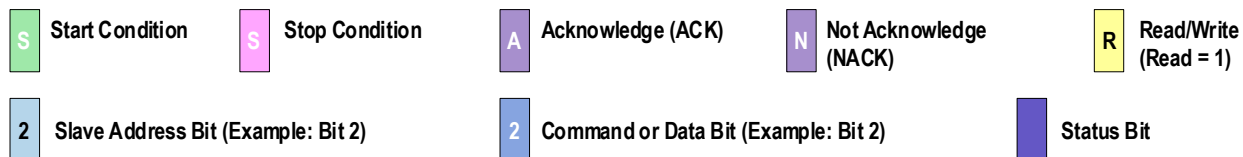

### 10.6.4.2 SPI Data Fetch

By default the SPI interface will have data change after the falling edge of SCLK. The master should sample MISO on the rising (opposite) edge of SCLK. This is configurable via the SPI\_Phase bit in EEPROM word Cust\_Config (see Table 12.5 for bit assignments). The SPI protocol can handle high and low polarity of the clock line without configuration change.

As seen in Figure 10.11 the entire output packet is 4 bytes (32 bits). The high capacitive data byte comes first, followed by the low byte. Then 14 bits of corrected temperature (T[13:0]) are sent: first the T[13:6] byte and then the {T[5:0],xx} byte. The last 2 bits of the final byte are undetermined and should be masked off in the application. If the user only requires the corrected capacitance value, the read can be terminated after the 2<sup>nd</sup> byte. If the corrected temperature is also required but only at an 8-bit resolution, the read can be terminated after the 3<sup>rd</sup> byte is read.

**Figure 10.11 SPI Output Packet with Positive Edge Sampling**

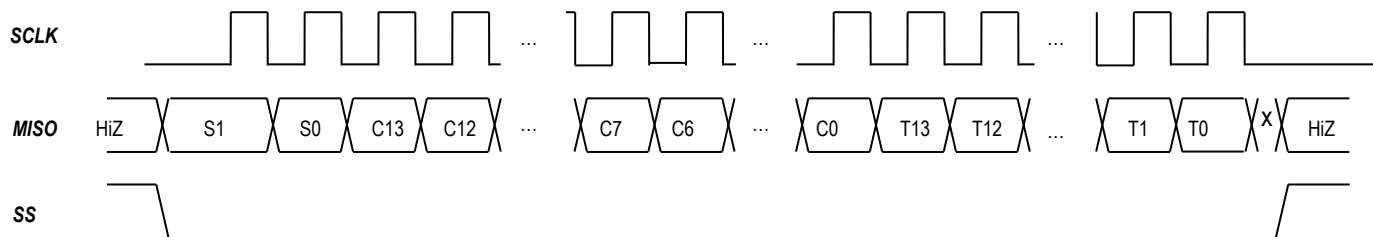

Packet = [ {S(1:0),C(13:8)}, {C(7:0)}, {T(13:6)}, {T(5:0),xx} ] Where  
 S(1:0) = Status bits of packet (normal, command, busy, diagnostic)  
 C(13:8) = Upper 6 bits of 14-bit capacitance data.  
 C(7:0) = Lower 8 bits of 14-bit capacitance data.  
 T(13:6) = Corrected temperature data (if application does not require corrected temperature, terminate read early)  
 T(5:0),xx = Remaining bits of corrected temperature data for full 14-bit resolution  
 HiZ = High impedance

### 10.6.5 Measurement Request (MR)

A measurement request (MR) is a Sleep-Mode-only command sent by the master to wake up the ZSSC3122 and start a new measurement cycle in both I2C and SPI modes. See section 10.3.2 for more information on Sleep Mode.

#### 10.6.5.1 I2C Measurement Request

The I2C MR is used to wake up the device in Sleep Mode and start a complete measurement cycle starting with a temperature measurement, followed by a capacitance measurement, followed by the DSP calculations, and then the results are written to the digital output register. As shown in Figure 10.12, the communication contains only the slave address and the WRITE bit (0) sent by the master. After the ZSSC3122 responds with the slave ACK, the master creates a stop condition.

**Note:** The I2C MR function can also be accomplished by sending “don’t care” data after the address instead of immediately sending a stop bit.

**Figure 10.12 I2C MR**

*I2C MR– Measurement Request: Slave starts a measurement cycle*

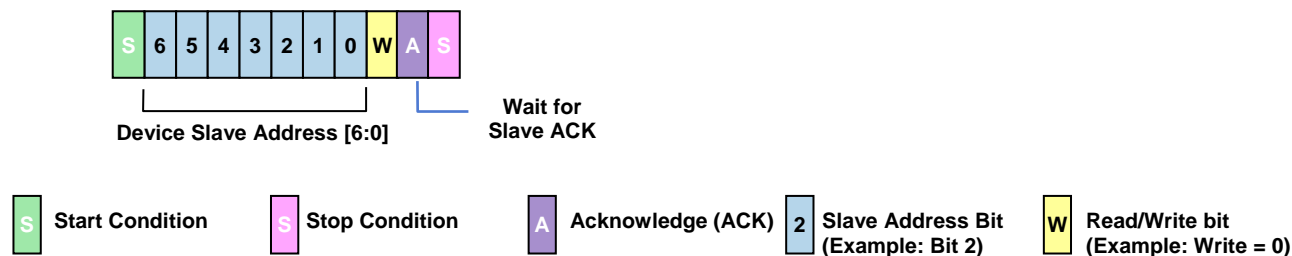



### 10.6.5.2 SPI Measurement Request

The SPI MR is used to wake up the device in Sleep Mode and start a complete measurement cycle starting with a temperature measurement/temperature DSP calculation, followed by a capacitance measurement / capacitance DSP calculations, and then the results are written to the digital output register. As shown in Figure 10.13, executing an SPI MR command is a read of 8 bits, ignoring the data that is returned.

**Note:** The SPI MR function can also be accomplished by performing a full SPI Data Fetch (see section 10.6.4.2) and ignoring the invalid data that will be returned.

**Figure 10.13 SPI MR**

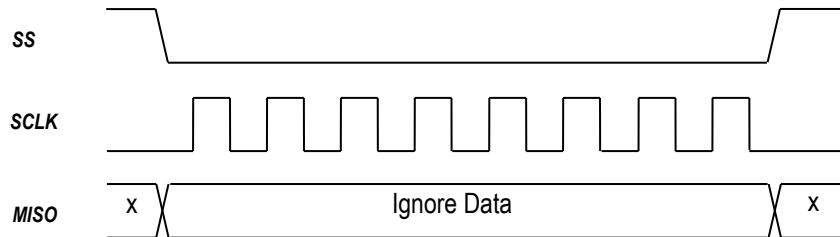

### 10.6.6 Ready Pin

A rise on the Ready pin indicates that new data is ready to be fetched from either the I2C or SPI interface. The Ready pin stays high until a Data Fetch (DF) command is sent (see section 10.6.3); it stays high even if additional measurements are performed before the DF. In Sleep Mode, sending a Measurement Request (MR) command resets the Ready pin.

The Ready pin's output driver type is selectable as either full push-pull or open drain via the Ready\_Open\_Drain bit in EEPROM word Cust\_Config (see Table 12.5 for bit assignments and settings). Point-to-point communication most likely uses the full push-pull driver. If an application requires interfacing to multiple parts, then the open-drain option can allow for just one wire and one pull-up resistor to connect all the parts in a bus format.

## 10.7 PDM (Pulse Density Modulation)

PDM outputs for both corrected capacitance and temperature are available. PDM\_C (capacitance PDM) appears on the READY/PDM\_C pin, and PDM\_T (temperature PDM) appears on the ALARM\_LOW/PDM\_T pin if enabled using the Output\_Selection bits (see Table 12.2). The typical PDM frequency is 231.25kHz (i.e., the oscillator frequency 1.85MHz  $\pm$  minimum/maximum corners of the oscillator frequency divided by 8). Both PDM signals are 14-bit values. In PDM Mode, the ZSSC3122 must be programmed to Update Mode (see section 10.3.1). Every time a conversion cycle has finished, the PDM will begin outputting the new value.

An analog output value is created by low-pass filtering the output; a simple first-order RC filter will work in this application.

Select the time constant of the filter based on the requirements for settling time and/or peak-to-peak ripple.

**Important:** The resistor of the RC filter must be  $\geq 10k\Omega$ .

Table 10.12 shows some filter examples using a 10k $\Omega$  resistor.

**Table 10.12 Low Pass Filter Example for R = 10kΩ**

Filter Capacitance (nF)	PDM_C		Desired Analog Output Resolution
	VPP Ripple (mV/V)	0 to 90% Settling Time (ms)	
100	4.3	2.3	8
400	1.0	9.2	10
1600	0.3	36.8	12
6400	0.1	147.2	14

For a different (higher) resistor, the normalized ripple VPP[mV/V] can be calculated as

$$VPP[mV/V] = \frac{4324}{(R[k\Omega] * C[nF])} \tag{14}$$

or the settling time t<sub>SETT</sub> for a 0% to 90% settling can be calculated as

$$t_{SETT} [ms] = 0.0023 * R[k\Omega] * C[nF] \tag{15}$$

ZSSC3122 provides high and low clipping limits for the PDM output. EEPROM words PDM\_Clip\_High and PDM\_Clip\_Low (EEPROM registers 16<sub>HEX</sub> and 17<sub>HEX</sub>; see Table 12.1) are the 14-bit high and low clipping limit registers respectively. The 14-bit values map directly to the output of the IC and can be calculated as

$$PDM\_Clip = ROUND\left(\frac{2^{14} * clip\_level\_ \%}{100}\right) \tag{16}$$

These registers apply to both PDM\_C and PDM\_T. Since diagnostics are reported in the PDM pin (see section 10.4), clipping limits allow diagnostics to be differentiated from the normal output. For detection of the diagnostic signal, a PDM\_Clip\_High limit of 97.5% (3E6<sub>HEX</sub>) or lower is recommended.

**Important:** The default values for the high and low clipping limits (00<sub>HEX</sub>) are not compatible with PDM output, so the clipping limits must be changed if the PDM output is used. Otherwise, the PDM output will not work as expected. If the PDM output is not used, it is important to retain the default values of 00<sub>HEX</sub> for the clipping limits.

## 10.8 Alarm Output

The alarm output can be used to monitor whether a corrected capacitance reading has exceeded or fallen below pre-programmed values. The alarm can be used to drive an open-drain load connected to VDD, as demonstrated in section 14.2, or it can function as a full push-pull driver. If a high voltage application is required, external devices can be controlled with the Alarm pins, as demonstrated in section 14.3.

The two alarm outputs can be used at the same time, and these alarms can be used in combination with any of the other three modes; I2C, SPI, or PDM.

**Note:** When both PMD\_C and PDM\_T are selected only Alarm\_High is available (see section 10.5).

The alarm outputs are updated when a conversion cycle is completed. The alarm outputs can be used in both Update Mode and Sleep Mode, but if Sleep Mode is used, I2C or SPI must also be used to control the measurements (see section 10.3).

### 10.8.1 Alarm Registers

Four registers are associated with the alarm functions: Alarm\_High\_On, Alarm\_High\_Off, Alarm\_Low\_On, and Alarm\_Low\_Off (see Table 12.1 for EEPROM addresses). Each of these four registers is a 14-bit value that determines where the alarms turn on or off. The two high alarm registers form the output with hysteresis for the Alarm\_High pin, and the two low alarm registers form the output with hysteresis for the Alarm\_Low pin. Each of the two alarm pins can be configured independently using Alarm\_Low\_Cfg and Alarm\_High\_Cfg located in EEPROM word Cust\_Config (see Table 12.5 for bit assignments).

**Note:** If two high alarms or two low alarms are needed, see section 10.8.4.

### 10.8.2 Alarm Operation

As shown in Figure 10.14, the Alarm\_High\_On register determines where the high alarm trip point is and the Alarm\_High\_Off register determines where the high alarm turns off if the high alarm has been activated. The high alarm hysteresis value is equal to Alarm\_High\_On – Alarm\_High\_Off. The same is true for the low alarm where Alarm\_Low\_On is the low alarm trip point with Alarm\_Low\_Off determining the alarm shut off point. The low alarm hysteresis value is equal to Alarm\_Low\_Off – Alarm\_Low\_On. Figure 10.15 shows output operation flowcharts for both the Alarm\_High and Alarm\_Low pins.

**Figure 10.14 Example of Alarm Function**

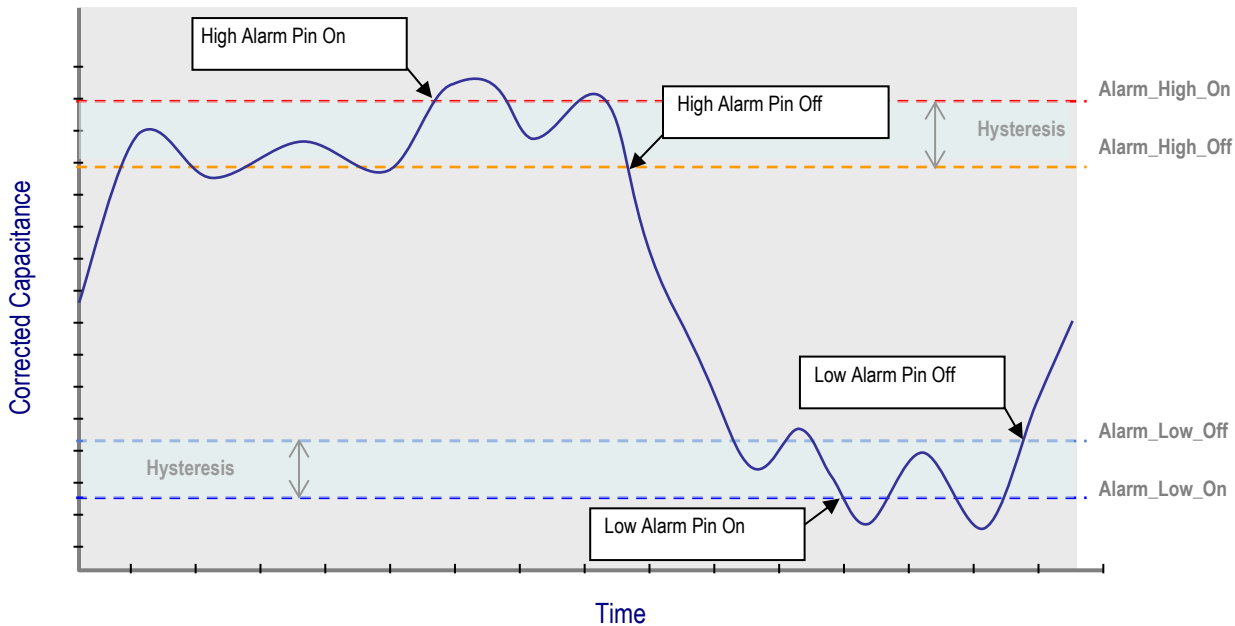

**Figure 10.15 Alarm Output Flow Chart**

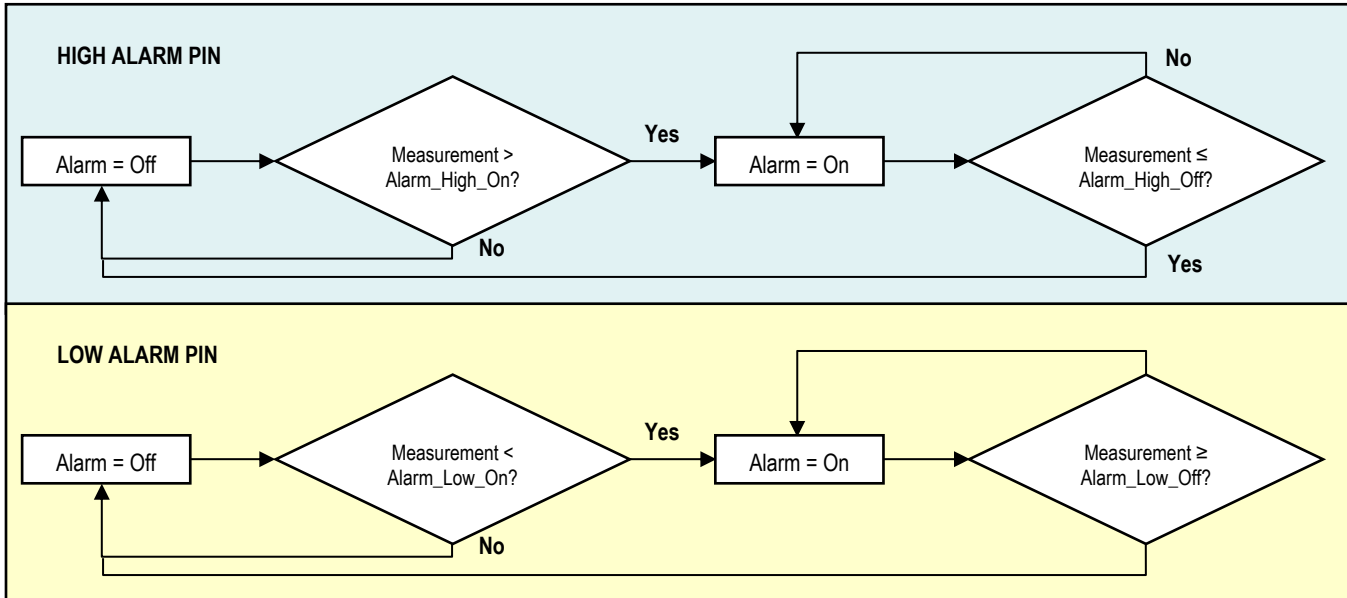

**10.8.3 Alarm Output Configuration**

The user can select the output driver configuration for each alarm using the Output Configuration bit in the Alarm\_High\_Cfg and Alarm\_Low\_Cfg registers in EEPROM word Cust\_Config (see Table 12.5 for bit assignments). For applications, such as interfacing with a microcontroller or controlling an external device (as seen in section 14.3), select the full push-pull driver for the alarm output type. For an application that directly drives a load connected to VDD, as demonstrated in section 14.2, the typical selection is the open-drain output type.

An advantage of making an alarm output open drain is that in a system with multiple devices, the alarm outputs of each ZSSC3122 can be connected together with a single pull-up resistance so that one can detect an alarm on any device with a single wire.

**10.8.4 Alarm Polarity**

For both alarm pins, the polarity of the alarm output is selected using the Alarm Polarity bit in the Alarm\_High\_Cfg and Alarm\_Low\_Cfg registers in EEPROM word Cust\_Config (see Table 12.5 for bit assignments). As shown in the example in section 14.3, the alarms can be used to drive a high voltage humidity control system. Since the humidifier or dehumidifier relays must be on when the alarms are on, the alarm polarity bits are set to 0 (active high). In the example given in section 14.2, an alarm is used to turn on an LED in an open drain configuration. In order for the LED to be on when the alarm is on, the output must be low, so the alarm polarity bit is set to 1 (active low).

Another feature of the polarity bits is the ability to create two high alarms or two low alarms. For example, with applications requiring two high alarms, flip the polarity bit of the Alarm\_Low pin, and it will act as a high alarm. However, in this case, the effect of the alarm low registers is also changed: the Alarm\_Low\_On register would act like the Alarm\_High\_Off register and the Alarm\_Low\_Off register would act like the Alarm\_High\_On register. The same can be done to achieve two low alarms: the Alarm\_High pin would have the polarity bit flipped, and the two Alarm\_High registers would have opposite meanings.

## 11. Command Mode

Command Mode is primarily used for calibrating the ZSSC3122. Command Mode is entered by sending a Start\_CM during the command window (see section 10.1 for more details on how to enter Command Mode). In Command Mode, a set of commands are available to the user to calibrate the part (see Table 11.1).

### 11.1 Command Format

Command Mode commands are only supported for the I2C protocol. As shown in Figure 11.1, commands are 4-byte packets with the first byte being a 7-bit slave address followed by 0 for write. The second byte is the command byte and the last two bytes form a 16-bit data field.

**Figure 11.1 I2C Command Format**

*I2C WRITE, Command Byte, and 2 Command Data Bytes*

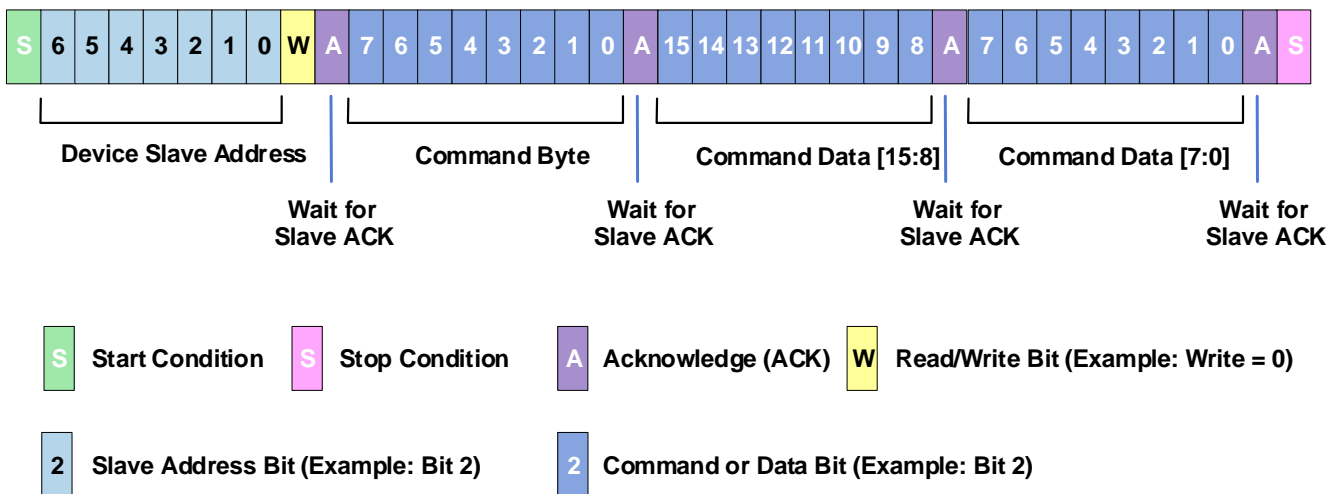

## 11.2 Command Encodings

Table 11.1 describes all the commands that are offered in Command Mode.

**Note:** Only the commands listed in Table 11.1 are valid. Other encodings might cause unpredictable results. If data is not needed for the command, zeros must be supplied as data to complete the 4-byte packet.

**Table 11.1 Command List and Encodings**

Command Byte 8 Command Bits (Hex)	Third and Fourth Bytes 16 Data Bits(Hex)	Description	Response Time <sup>[a]</sup>
00 <sub>HEX</sub> to 1F <sub>HEX</sub>	0000 <sub>HEX</sub>	EEPROM read of addresses 00 <sub>HEX</sub> to 1F <sub>HEX</sub> . After this command has been sent and executed, a data fetch must be performed (see section 10.6.4).	100μs
40 <sub>HEX</sub> to 5F <sub>HEX</sub>	YYYY <sub>HEX</sub> (Y = data)	Write to EEPROM addresses 00 <sub>HEX</sub> to 1F <sub>HEX</sub> . The 2 bytes of data sent will be written to the address specified in the 6 LSBs of the command byte.	12ms
80 <sub>HEX</sub>	0000 <sub>HEX</sub>	Start_NOM. Ends Command Mode and transitions to Normal Operation Mode.	Length of initial conversions depends on temperature and capacitance resolution settings (see section 10).
A0 <sub>HEX</sub>	0000 <sub>HEX</sub>	Start_CM. Start Command Mode: used to enter the command interpreting mode. Start_CM is only valid during the power-on command window (see section 10.1).	100μs
B0 <sub>HEX</sub>	0000 <sub>HEX</sub>	Get Revision. Get the revision of the part. After this command has been sent and executed, a data fetch must be performed (see section 10.6.4).	100μs

[a] All time values shown are typical; for the worst case values, multiply by 1.1 (nominal frequency ±10%).

## 11.3 Command Response and Data Fetch

After a command has been sent and the execution time defined in Table 11.1 has expired, an I2C Data Fetch (DF) can be performed to fetch the response. As shown in Figure 11.2, after the slave address has been sent, the first byte fetched is the response byte. The upper two status bits will always be 10<sub>BIN</sub> to represent Command Mode (see section 10.4). The lower two bits are the response bits.

Table 11.3 describes the different responses that can be fetched. To determine if a command has finished executing, poll the part until a Busy response is no longer received. The middle four bits of the response byte are command diagnostic bits where each bit represents a different diagnostic (see Table 11.3). For more information on EEPROM errors see section 10.4.1.

**Note:** Regardless of what the response bits are, one or more of the diagnostic bits may be set indicating an error occurred during the execution of the command.

**Note:** Only one command can be executed at a time. After a command is sent, another command must not be sent until the execution time of the first command defined in Table 11.1 has expired.

For all commands except EEPROM Read and Get Revision, the data fetch should be terminated after the response byte is read. If the command was a Get Revision, then the user will fetch a one-byte Revision as shown in Figure 11.2, example 2. The revision is coded with the upper nibble being the letter corresponding to a full layer change and the lower nibble being the metal change number, for example A0. If the command was an EEPROM Read, then the user will fetch two more bytes as shown in Figure 11.2, example 3. If a Corrected EEPROM Error diagnostic was flagged after an EEPROM read, the user has the option to write this data back to attempt to fix the error.

Instead of polling to determine if a command has finished executing, the user can use the Ready pin. In this case, wait for the Ready pin to rise, which indicates that the command has executed. Then a data fetch can be performed to get the response and data (see Figure 11.2). See section 10.6.6 for more information on the Ready pin.

**Table 11.2 Response Bits**

Encoding	Name	Description
00 <sub>BIN</sub>	Busy	The command is busy executing.
01 <sub>BIN</sub>	Positive Acknowledge	The command executed successfully.
10 <sub>BIN</sub>	Negative Acknowledge	The command was not recognized or an EEPROM write was attempted while the EEPROM was locked.

**Table 11.3 Command Diagnostic Bits**

Bit Position	Name	Description
2	Corrected EEPROM Error	A corrected EEPROM error occurred in execution of the last command.
3	Uncorrectable EEPROM Error	An uncorrectable EEPROM error occurred in execution of the last command.
4	RAM Parity Error	A RAM parity error occurred during a microcontroller instruction in the execution of the last command.
5	Configuration Error	An EEPROM or RAM parity error occurred in the initial loading of the configuration registers.

**Figure 11.2 Command Mode Data Fetch**

(1) *I2C DF* – Command Status Response – 1 Byte

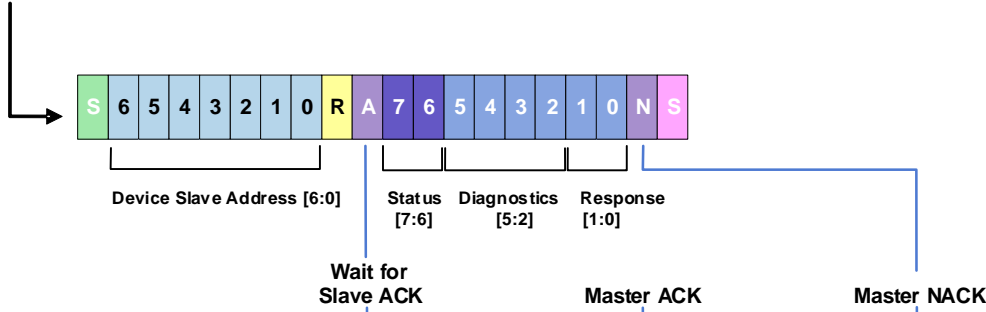

(2) *I2C Get Revision DF* – Command Status Response and cLite™ Revision – 2 Bytes

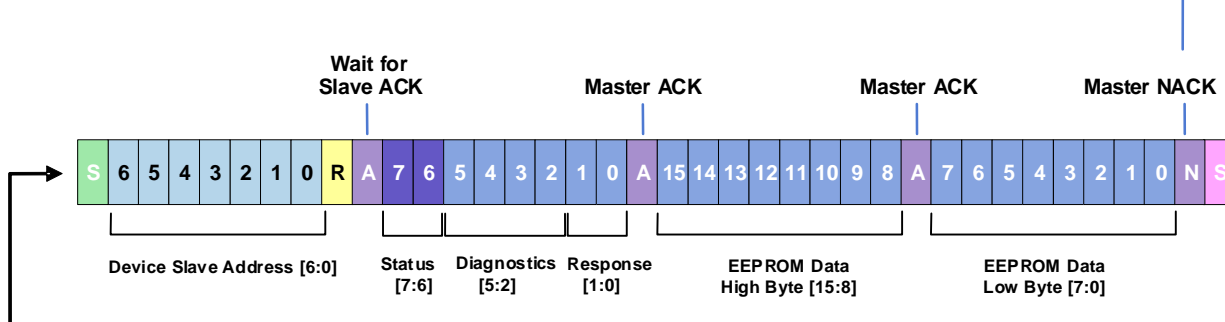

(3) *I2C EEPROM DF* – Command Status Response and EEPROM Data Fetch – 3 Bytes

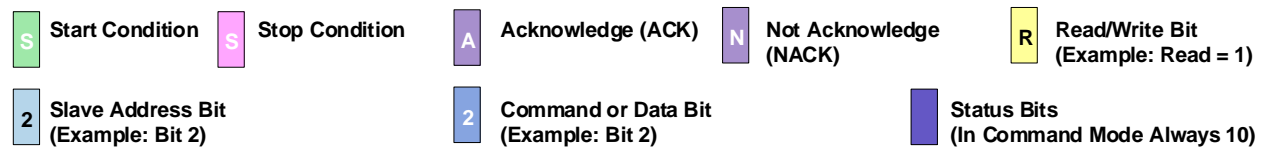



## 12. EEPROM

The EEPROM array contains the calibration coefficients for gain and offset, etc., and the configuration bits for the analog front-end, output modes, measurement modes, etc. The ZSSC3122 EEPROM is arranged as 32 16-bit words (see Table 12.1). The EEPROM is divided into two sections. Words 0<sub>HEX</sub> to 15<sub>HEX</sub> can only be written to if the EEPROM is unlocked. After the EEPROM is locked, these locations can no longer be written to. The EEPROM lock bits are in the ZMDI\_Config register (see Table 12.2 for the bit assignment). Words 16<sub>HEX</sub> to 1F<sub>HEX</sub> (highlighted blue in Table 12.1) are always unlocked and available to write to at all times. See section 11 for instructions on reading and writing to the EEPROM in Command Mode via the I2C interface. When programming the EEPROM, an internal charge pump voltage is used; therefore a high voltage supply is not needed.

**Note:** If the EEPROM was accidentally locked, it can be unlocked with the following instructions (see section 11 for how to send commands).

1. Enter Command Mode with a Start\_CM command.
2. Send an A2<sub>HEX</sub> for the command byte and 0000<sub>HEX</sub> for the command data.
3. Send an F0<sub>HEX</sub> for the command byte and 0021<sub>HEX</sub> for the command data.
4. Clear the EEPROM\_Lock bits in the ZMDI\_Config register with an EEPROM Write command.
5. Reset the part.

There are four Customer\_ID words available for customer use: two in the locked region and two in the unlocked region. They can be used as a customer serial number for module traceability. (See Table 12.1 for Customer\_ID EEPROM addresses.) The integrity of the contents of the EEPROM array is ensured via ECC (see section 10.4.1).

Table 12.1 provides a summary of the EEPROM contents. The configuration register bits are explained in detail in the following subsections.

**Table 12.1 EEPROM Word Assignments**

EEPROM Word	Bit Range	IC Default	Name	Description and Notes
00 <sub>HEX</sub>	15:0	XXXX <sub>HEX</sub>	Cust_ID0	Customer ID byte 0: For use by customer (default value is the upper 16 bits of the lot number).
01 <sub>HEX</sub>	15:0	XXXX <sub>HEX</sub> (LLLLLLLL <sub>BIN</sub> 0000SSSS <sub>BIN</sub> )	Cust_ID1	Customer ID byte 1: For use by customer (default value is the lower 8 bits of the lot number and an 8 bit wafer number).
02 <sub>HEX</sub>	15:0	0B00 <sub>HEX</sub>	ZMDI_Config	IDT configuration register (see section 12.1).
03 <sub>HEX</sub>	15:0	0006 <sub>HEX</sub>	Not Available	Do not change; must leave at factory settings.
04 <sub>HEX</sub>	15:0	00FT <sub>HEX</sub>	Not Available	Do not change; must leave at factory settings. Note: The T in the default setting for EEPROM word 04 <sub>HEX</sub> represents the custom trim value determined by final test. Do not change this setting.
05 <sub>HEX</sub>	15:0	0000 <sub>HEX</sub>	Not Available	Do not change; must leave at factory settings.
06 <sub>HEX</sub>	15:0	0C06 <sub>HEX</sub>	C_Config	AFE capacitance configuration register (see Table 12.3).
07 <sub>HEX</sub>	15:0	0000 <sub>HEX</sub>	SOT_tco	2 <sup>nd</sup> order temperature offset correction for capacitance.
08 <sub>HEX</sub>	15:0	0000 <sub>HEX</sub>	Tco	Temperature offset correction for capacitance.
09 <sub>HEX</sub>	15:0	0000 <sub>HEX</sub>	SOT_tcg	2 <sup>nd</sup> order temperature gain correction for capacitance.
0A <sub>HEX</sub>	15:0	0000 <sub>HEX</sub>	Tcg	Temperature gain correction for capacitance.
0B <sub>HEX</sub>	15:0	0000 <sub>HEX</sub>	Offset	Offset correction for capacitance.

EEPROM Word	Bit Range	IC Default	Name	Description and Notes
0C <sub>HEX</sub>	15:0	2000 <sub>HEX</sub>	Gain_1	Gain correction for capacitance (region 1).
0D <sub>HEX</sub>	15:0	0000 <sub>HEX</sub>	SOT_1	2 <sup>nd</sup> order correction for capacitance (region 1).
0E <sub>HEX</sub>	15:0	2000 <sub>HEX</sub>	Gain_2	Gain correction for capacitance (region 2).
0F <sub>HEX</sub>	15:0	0000 <sub>HEX</sub>	SOT_2 Or TOT_1	2 <sup>nd</sup> order correction for capacitance (region 2); alternatively 3 <sup>rd</sup> order correction (only one region).
10 <sub>HEX</sub>	15:0	7FFF <sub>HEX</sub>	Raw_Break	Break point dividing region 1 from region 2.
11 <sub>HEX</sub>	15:0	8D92 <sub>HEX</sub>	T_Config	AFE temperature configuration register (see Table 12.4).
12 <sub>HEX</sub>	15:0	0000 <sub>HEX</sub>	Offset_T	Offset correction for temperature.
13 <sub>HEX</sub>	15:0	2000 <sub>HEX</sub>	Gain_T	Gain correction for temperature.
14 <sub>HEX</sub>	15:0	0000 <sub>HEX</sub>	SOT_T	2 <sup>nd</sup> order correction for temperature.
15 <sub>HEX</sub>	15:0	0000 <sub>HEX</sub>	T <sub>REF</sub>	Raw temperature reading reference point.
16 <sub>HEX</sub>	13:0	0000 <sub>HEX</sub>	PDM_Clip_High	PDM high clipping limit (keep at zero unless PDM is enabled; must change default if PDM is used).
17 <sub>HEX</sub>	13:0	0000 <sub>HEX</sub>	PDM_Clip_Low	PDM low clipping limit (keep at zero unless PDM is enabled; may be changed if PDM is used).
18 <sub>HEX</sub>	13:0	3FFF <sub>HEX</sub>	Alarm_High_On	High alarm on trip point.
19 <sub>HEX</sub>	13:0	3FFF <sub>HEX</sub>	Alarm_High_Off	High alarm off trip point.
1A <sub>HEX</sub>	13:0	0000 <sub>HEX</sub>	Alarm_Low_On	Low alarm on trip point.
1B <sub>HEX</sub>	13:0	0000 <sub>HEX</sub>	Alarm_Low_Off	Low alarm off trip point.
1C <sub>HEX</sub>	15:0	0028 <sub>HEX</sub>	Cust_Config	Customer configuration register (see section 12.4.)
1D <sub>HEX</sub>	15:0	0000 <sub>HEX</sub>	Not Available	Do not change; must leave at factory settings.
1E <sub>HEX</sub>	15:0	XXXX <sub>HEX</sub>	Cust_ID2	Customer ID byte 2: For use by customer (default value is the 8-bit x and 8-bit y coordinates on the wafer).
1F <sub>HEX</sub>	15:0	0000 <sub>HEX</sub>	Cust_ID3	Customer ID byte 3: For use by customer.

## 12.1 IDT Configuration Register (ZMDI\_Config, EEPROM Word 02<sub>HEX</sub>)

This register is loaded at power-on reset and upon exiting Command Mode using a Start\_NOM command.

**Table 12.2 ZMDI\_Config Bit Assignments**

Bit Range	IC Default	Name	Description and Notes
0	0 <sub>BIN</sub>	Measurement_Mode	0 = Update Mode 1 = Sleep Mode
2:1	00 <sub>BIN</sub>	Power_Down_Period	Power Down Period: 00 <sub>BIN</sub> = 0ms 01 <sub>BIN</sub> = 5ms 10 <sub>BIN</sub> = 25ms 11 <sub>BIN</sub> = 125ms Note: All time values shown are typical; for the worst case values, multiply by 1.1 (nominal frequency $\pm 10\%$ ).
3	0 <sub>BIN</sub>	Scale_Sot_Tc	Scales the SOT TC Terms: 0 = Scale x 1 1 = Scale x 2
4	0 <sub>BIN</sub>	Gain4x_C	Multiply Gain_1 and Gain_2 by 0 = multiply by 1 1 = multiply by 4
7:5	000 <sub>BIN</sub>	EEPROM_lock	011 <sub>BIN</sub> = locked All other = unlocked When EEPROM is locked, the internal charge pump is disabled and the EEPROM can no longer be programmed. <b>Note:</b> If the EEPROM was accidentally locked, see section 12 for instructions for unlocking it.
10:8	011 <sub>BIN</sub>	Comm_lock	011 <sub>BIN</sub> = locked All other = unlocked When communication is locked, I2C communication will only respond to its programmed address. Otherwise if communication is unlocked, I2C will respond to any address.
13:11	001 <sub>BIN</sub>	Output_Selection	001 <sub>BIN</sub> = I2C 011 <sub>BIN</sub> = SPI 100 <sub>BIN</sub> = PDM Capacitance (+ 2 alarms) 110 <sub>BIN</sub> = PDM Capacitance + Temperature (+ 1 alarm) All other configurations are not allowed. See Table 10.8 for more details.
14	0 <sub>BIN</sub>	Third_order	0 = Piece-wise linear calibration with breakpoint 1 = Third-order calibration
15	0 <sub>BIN</sub>	Not Available	<b>Do Not Change</b> – must leave at factory settings

## 12.2 Capacitance Analog Front-End Configuration (C\_Config, EEPROM Word 06<sub>HEX</sub>)

This register is loaded immediately before a capacitance measurement is taken, so a power cycle is not needed for changes to take effect.

**Table 12.3 C\_Config Bit Assignments**

Bit Range	IC Default	Name	Description and Notes
2:0	110 <sub>BIN</sub>	CDC_Reference	CDC reference capacitor selection (see Table 9.1).
5:3	000 <sub>BIN</sub>	CDC_Offset	CDC offset capacitor selection (see Table 9.1)
9:6	0000 <sub>BIN</sub>	Not Available	<b>Do Not Change</b> – must leave at factory settings.
11:10	11 <sub>BIN</sub>	Resolution	CDC resolution and sample rate: 00 <sub>BIN</sub> = 8 bits at 0.7 ms rate 01 <sub>BIN</sub> = 10 bits at 1.6 ms rate 10 <sub>BIN</sub> = 12 bits at 5.0 ms rate 11 <sub>BIN</sub> = 14 bits at 18.5 ms rate Note: All time values shown are typical; for the worst case values, multiply by 1.1 (nominal frequency ±10%). See section 10.2 for additional timing factors.
13:12	00 <sub>BIN</sub>	Not Available	<b>Do Not Change</b> – must leave at factory settings.
14	0 <sub>BIN</sub>	Differential	Differential input capacitance selection: 0 = Single-ended 1 = Differential
15	0 <sub>BIN</sub>	Not Available	<b>Do Not Change</b> – must leave at factory settings.

## 12.3 Temperature Analog Front-End Configuration (T\_Config, EEPROM Word 11<sub>HEX</sub>)

This register is loaded immediately before a capacitance measurement is taken, so a power cycle is not needed for changes to take effect.

**Table 12.4 T\_Config Bit Assignments**

Bit Range	IC Default	Name	Description and Notes
2:0	010 <sub>BIN</sub>	CDC_Reference	CDC reference capacitor selection. The factory settings are set for a full span temperature range from -20°C to +125°C. <b>Note:</b> Do not change this setting from the factory setting unless a different temperature range is needed.
5:3	010 <sub>BIN</sub>	CDC_Offset	CDC offset capacitor selection. The factory settings are set for a full span temperature range from -20°C to +125°C. <b>Note:</b> Do not change this setting from the factory setting unless a different temperature range is needed.
8:6	110 <sub>BIN</sub>	Temp_Trim	Trim setting used for the temperature measurement. The factory settings are set for a full span temperature range from -20°C to +125°C. <b>Note:</b> Do not change this setting from the factory setting unless a different temperature range is needed.
9	0 <sub>BIN</sub>	Not Available	<b>Do Not Change</b> – must leave at factory settings.
11:10	11 <sub>BIN</sub>	Resolution	Temperature resolution and sample rate: 00 <sub>BIN</sub> = 8 bits at 0.7ms rate 01 <sub>BIN</sub> = 10 bits at 1.6ms rate 10 <sub>BIN</sub> = 12 bits at 5.0ms rate 11 <sub>BIN</sub> = 14 bits at 18.5ms rate <b>Note:</b> All time values shown are typical; for the worst case values, multiply by 1.1 (nominal frequency ±10%).
15:12	1000 <sub>BIN</sub>	Not Available	<b>Do Not Change</b> – must leave at factory settings.

## 12.4 Customer Configuration Register (Cust\_Config, EEPROM Word 1C<sub>HEX</sub>)

This register is loaded at power-on reset and upon exiting Command Mode after receiving a Start\_NOM command.

**Table 12.5 Cust\_Config Bit Assignments**

Bit Range	IC Default	Name	Description and Notes						
6:0	0101000 <sub>BIN</sub>	Device_ID	I2C slave address.						
8:7	00 <sub>BIN</sub>	Alarm_Low_Cfg	Configure the Alarm_Low output pin: <table border="1"> <thead> <tr> <th>Bits</th> <th>Description</th> </tr> </thead> <tbody> <tr> <td>7</td> <td>Alarm Polarity: 0 = Active High 1 = Active Low</td> </tr> <tr> <td>8</td> <td>Output Configuration: 0 = Full push-pull 1 = Open drain</td> </tr> </tbody> </table>	Bits	Description	7	Alarm Polarity: 0 = Active High 1 = Active Low	8	Output Configuration: 0 = Full push-pull 1 = Open drain
Bits	Description								
7	Alarm Polarity: 0 = Active High 1 = Active Low								
8	Output Configuration: 0 = Full push-pull 1 = Open drain								
10:9	00 <sub>BIN</sub>	Alarm_High_Cfg	Configure the Alarm_High output pin: <table border="1"> <thead> <tr> <th>Bits</th> <th>Description</th> </tr> </thead> <tbody> <tr> <td>9</td> <td>Alarm Polarity: 0 = Active High 1 = Active Low</td> </tr> <tr> <td>10</td> <td>Output Configuration: 0 = Full push-pull 1 = Open drain</td> </tr> </tbody> </table>	Bits	Description	9	Alarm Polarity: 0 = Active High 1 = Active Low	10	Output Configuration: 0 = Full push-pull 1 = Open drain
Bits	Description								
9	Alarm Polarity: 0 = Active High 1 = Active Low								
10	Output Configuration: 0 = Full push-pull 1 = Open drain								
11	0 <sub>BIN</sub>	SPI_Phase	The edge of SCLK that the master samples MISO on: 0 = positive edge 1 = negative edge						
12	0 <sub>BIN</sub>	Ready_Open_Drain	Ready pin is 0 = Full push-pull 1 = Open drain						
13	0 <sub>BIN</sub>	Fast_Startup	Sets the Command Window length: 0 = 10ms Command Window 1 = 3ms Command Window						
15:14	00 <sub>BIN</sub>	Not Available	<b>Do Not Change</b> – must leave at factory settings.						

## 13. Calibration and Signal Conditioning Math

IDT can provide software and hardware with samples to perform the calibration. For a complete description and detailed examples, see the *ZSSC3122/ZSSC3123\_SSC\_Modular\_Evaluation\_Kit\_Description\_RevX\_xy.pdf*.

**Note** For best results, the calibration should be done with all settings set to the final application including supply voltage, measurement mode, update rate, output mode, resolution, and AFE settings in the final packaging.

### 13.1 Capacitance Signal Conditioning

The ZSSC3122 supports up to a two-region piece-wise, nonlinear sensor input or a third-order correction selectable. The general form of the capacitance signal conditioning equation is provided below.

**Note:** The following equations are only meant to show the general form and capabilities of the ZSSC3122 sensor signal conditioning.

#### Two-region piece-wise, nonlinear sensor input

$$RawTC = \frac{Raw\_C + OFFSET + \Delta T * (Tco + \Delta T * SOT\_tco)}{1 + \Delta T * (Tcg + \Delta T * SOT\_tcg)} \quad (17)$$

$$Raw_1 = MIN(RawTC, Raw\_Break) \quad (18)$$

$$Raw_2 = MAX(0, RawTC - Raw\_Break) \quad (19)$$

$$Out = SOT\_1 * (Gain\_1 * Raw_1)^2 + Gain\_1 * Raw_1 + SOT\_2 * (Gain\_2 * Raw_2)^2 + Gain\_2 * Raw_2 \quad (20)$$

Or alternatively

#### Nonlinear sensor input up to third-order correction

$$Raw_1 = \frac{Raw\_C + OFFSET + \Delta T * (Tco + \Delta T * SOT\_tco)}{1 + \Delta T * (Tcg + \Delta T * SOT\_tcg)} \quad (21)$$

$$Out = TOT\_1 * (Gain\_1 * Raw_1)^3 + SOT\_1 * (Gain\_1 * Raw_1)^2 + Gain\_1 * Raw_1 \quad (22)$$

Where:

<i>Raw_C</i>	Raw sensor reading.
<i>RawTC</i>	Temperature corrected raw value.
<i>Raw<sub>1</sub></i>	Raw value to be used for region 1 correction.
<i>Raw<sub>2</sub></i>	Raw value used for region 2 correction.
<i>Raw_Break</i>	Raw value at which the transition from region 1 to region 2 occurs.
<i>Offset</i>	Offset correction for sensor applied at 50% full scale input.
<i>Gain<sub>1</sub></i>	Gain correction for sensor applied to region 1.
<i>SOT<sub>1</sub></i>	Second-order correction for sensor region 1.

<i>Gain_2</i>	Gain correction for sensor applied to region 2 – not used if only 1 region is used.
<i>SOT_2</i> <i>alternatively</i> <i>TOT_1</i>	Second-order correction for sensor region 2 – not used if only 1 region is used. Used as third-order term TOT_1 for third-order correction.
<i>Tco</i>	Correction for offset drift due to temperature.
<i>Tcg</i>	Correction for sensitivity (gain) change due to temperature.
<i>SOT_tco</i>	Second-order correction for offset drift due to temperature.
<i>SOT_tcg</i>	Second-order correction for sensitivity change due to temperature.
<i>T<sub>REF</sub></i>	Raw temperature reading used as a reference temperature for the removal of all TC components.
$\Delta T$	Difference between current raw temperature and the reference temperature.
<i>OUT</i>	Corrected capacitance output value.

### 13.2 Temperature Signal Compensation

Temperature is measured internally. Temperature correction contains both linear gain and offset terms as well as a second-order term to correct for any nonlinearity.

**Note:** The following equation is only meant to show the general form and capabilities of the internal ZSSC3122 temperature signal conditioning.

$$T = SOT\_T * (Raw\_T)^2 + Gain\_T * Raw\_T + Offset\_T \tag{23}$$

Where:

Raw_T	[0,16383]	Raw temperature reading
Gain_T	[-32768,32767]	Gain correction for internal temperature
Offset_T	[-32768,32767]	Offset correction for internal temperature
SOT_T	[-32768,32767]	Second-order correction for internal temperature
T	[-32768,32767]	Corrected temperature output value

### 13.3 Limits on Coefficient Ranges

There are range limits on some of the calibration coefficients that will be enforced by the calibration routine provided by IDT. These limits ensure the integrity of the internal calculations and would only limit the most extreme cases of sensor correction.

**Note:** For Alarm-only applications, it is critical that the coefficient verification feature of the calibration routine is used since diagnostics are not reported for the Alarms (see section 10.4 for more details)

Table 13.1 shows the limits for correction for the grade of temperature dependency and 2<sup>nd</sup> nonlinearity of this dependency.

**Table 13.1 Limits on Coefficient Ranges**

Coefficient	Correction	Condition
TCO	6060 PPM/K	
SOT_TCO	74 PPM/K <sup>2</sup>	
TCG	12120 PPM/K	Based on raw temperature values
SOT_TCG	147 PPM/K <sup>2</sup>	Based on raw temperature values



## 14. Application Circuit Examples

The ZSSC3122 provides functionality for many different configurations. The following examples correspond to the example circuits shown at the beginning of the specification; however, there are many other possibilities. Combinations of these examples and many other options can give the user maximum design flexibility. Settings for the configuration registers are given with each example. See Table 12.1 for register addresses. In the examples below bits 3 and 4 of the ZMDI\_Config register are marked with an X because they are calculated during calibration and are coefficient dependent (see section 13).

### 14.1 Digital Output with Optional Alarms

In this example, a single-ended input capacitance is converted to the digital domain, corrected, and output via I2C. The configuration settings are shown in Table 14.1 below. The ZSSC3122 operates in Sleep Mode, in which measurement commands are used during normal operation. In this example, the I2C address is 28<sub>HEX</sub> and the Comm\_lock is set.

In this application, both Alarm\_High and Alarm\_Low are used for digital communication. As shown in Table 14.1 below, both alarms are configured as active high and full push-pull drivers for digital communication.

The AFE configuration registers select 14-bit resolution for capacitance with a capacitance range from 2.9pF to 7.2pF. The internal temperature is set to 14-bit resolution.

**Figure 14.1 Digital Output with Optional Alarms Example**

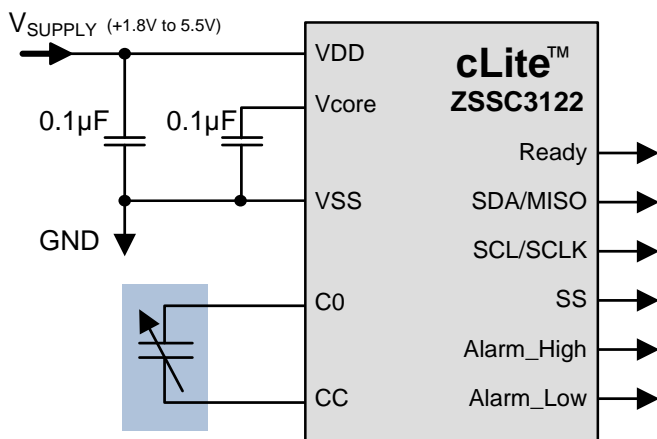

**Table 14.1 Example 1: Configuration Settings**

Configuration Register	15	14	13	12	11	10	9	8	7	6	5	4	3	2	1	0
ZMDI_Config (Table 12.2)	0 [a]	0	0	0	1	0	1	1	0	0	0	X	X	0	0	1
Cust_Config (Table 12.5)	0 [a]	0 [a]	0	0	0	0	0	0	0	0	1	0	1	0	0	0
C_Config (Table 12.3)	0 [a]	0	0	0	1	1	0 [a]	0 [a]	0 [a]	0 [a]	0	1	0	0	1	1
T_Config (Table 12.4)	1 [a]	0 [a]	0 [a]	0 [a]	1	1	0 [a]	1 [b]	1 [b]	0 [b]	0 [b]	1 [b]	0 [b]	0 [b]	1 [b]	0 [b]

[a] Reserved setting – do not change factory settings.

[b] The factory settings are set for a full span temperature range from -20°C to +125°C. Do not change this setting unless a different temperature range is needed.

## 14.2 Analog Output with Optional Alarms

In this example, a single-ended input capacitance is converted and corrected, and then both capacitance and temperature are output via PDM, which are then low-pass filtered for analog outputs. One of the optional alarms controls an LED. The configuration settings are shown below in Table 14.2. In the ZMDI\_Config register, the output selection bits are set to 10 to select PDM. Example low-pass filter values are given in section 10.7.

For PDM, Update Mode must be selected. In this application example, a 25ms power-down period has been used.

In this application, Alarm\_High is used to turn on an LED in an open-drain configuration. The output must be low for the LED to be on, so the Alarm\_High polarity bit is set to active low. The PDM clipping limits are set for 10% (666<sub>HEX</sub>) to 90% (3999<sub>HEX</sub>) output.

The AFE configuration registers show a resolution of 14 bits for capacitance; however, the PDM low pass filter may be set for a lower resolution with a faster settling time (see section 10.7). A capacitance range of 1.4pF to 8.6pF has been chosen. The internal temperature is set to 12-bit resolution.

**Figure 14.2 Analog Output with Optional Alarms Example**

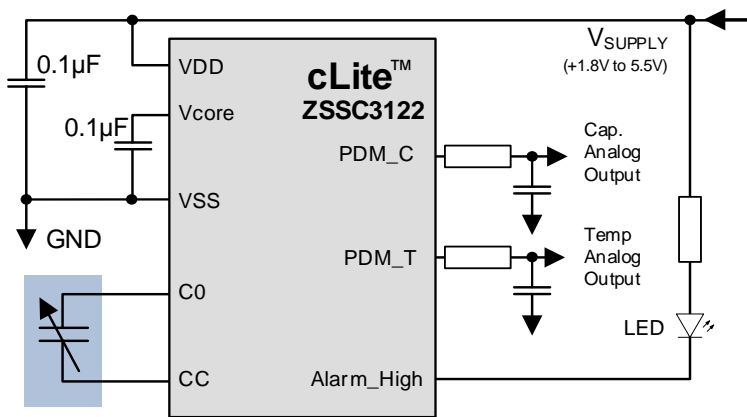

**Table 14.2 Example 2: Configuration Settings**

Configuration Register	15	14	13	12	11	10	9	8	7	6	5	4	3	2	1	0
ZMDI_Config (Table 12.2)	0 [a]	0	1	1	0	0	1	1	0	0	0	X	X	1	0	0
Cust_Config (Table 12.5)	0 [a]	0 [a]	0	0	0	0	1	0	0	0	1	0	1	0	0	0
C_Config (Table 12.3)	0 [a]	0	0	0	1	1	0 [a]	0 [a]	0 [a]	0 [a]	0	0	1	1	0	1
T_Config (Table 12.4)	1 [a]	0 [a]	0 [a]	0 [a]	1	0	0 [a]	1 [b]	1 [b]	0 [b]	0 [b]	1 [b]	0 [b]	0 [b]	1 [b]	0 [b]
PDM_Clip_High	0	0	1	1	1	0	0	1	1	0	0	1	1	0	0	1
PDM_Clip_Low	0	0	0	0	0	1	1	0	0	1	1	0	0	1	1	0

[a] Reserved setting – do not change factory settings.

[b] The factory settings are set for a full span temperature range from -20°C to +125°C. Do not change this setting unless a different temperature range is needed.

### 14.3 Bang-Bang Control System

In this example, the only outputs are the alarm pins. They are programmed to control a high voltage bang-bang humidity control system. External devices are not needed if not using high voltage.

If the humidity gets too high, the ZSSC3122 activates the dehumidifier using the Alarm\_High pin. If the humidity gets too low, it activates the humidifier with the Alarm\_Low pin. The alarm registers must be set to appropriate trip and hysteresis points (see section 10.8). The configuration settings are shown in Table 14.3.

The output selection bits should either be set to I2C or SPI since depending on the PDM configuration, both alarms are not supported. Additionally, I2C and SPI are lower power than PDM. This application does not use I2C or SPI, so Update Mode must be used because Sleep Mode commands cannot be sent. The fastest update rate is used for this example. External devices are needed to control the outputs because a voltage source greater than VDD is used.

**Figure 14.3 Bang-Bang Control System Example**

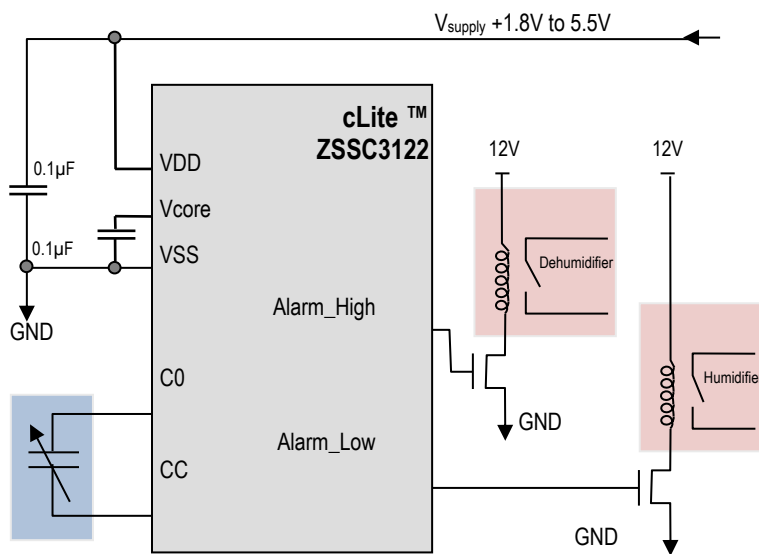

The alarm pins control NMOS devices so the alarm pins must be full push-pull and output high when the alarm is on, so the polarity bits are set to 0 and the open drain bits are set to 0.

In this example application, a faster response time may be needed, so the AFE configuration settings show 10-bit resolution for both capacitance and internal temperature. C\_Config settings have been selected for a capacitance range of 5.8pF to 7.2pF (see Table 9.1).

**Table 14.3 Example 3: Configuration Settings**

Configuration Register	15	14	13	12	11	10	9	8	7	6	5	4	3	2	1	0
ZMDI_Config (Table 12.2)	0 [a]	0	0	0	1	0	1	1	0	0	0	X	X	0	0	0
Cust_Config (Table 12.5)	0 [a]	0 [a]	0	0	0	0	0	0	0	0	1	0	1	0	0	0
C_Config (Table 12.3)	0 [a]	0	0	0	0	1	0 [a]	0 [a]	0 [a]	0 [a]	1	0	0	0	0	1
T_Config (Table 12.4)	1 [a]	0 [a]	0 [a]	0 [a]	0	1	0 [a]	1 [b]	1 [b]	0 [b]	0 [b]	1 [b]	0 [b]	0 [b]	1 [b]	0 [b]

[a] Reserved setting – do not change factory settings.

[b] The factory settings are set for a full span temperature range from -20°C to +125°C. Do not change this setting unless a different temperature range is needed.

### 14.4 Differential Input Capacitance

This example shows that the full functionality of the ZSSC3122 including the applications illustrated in examples 1, 2, and 3, can be implemented with a differential input capacitance. The capacitor  $C_{CC}$  allows a non-galvanic connection (e.g., to the moving part of a motion sensor as part of the sensor construction), but it is not needed for sensor types with existing galvanic connections.

The configuration settings are shown in Table 14.4. The differential bit is set to select differential input capacitance. In this example, SPI has been selected in Update Mode at the fastest update rate. The SPI phase is set to 1 so that the master samples MISO on the negative edge of SCLK. The EEPROM has been locked.

The AFE configuration registers select 14-bit resolution for capacitance and 10-bit resolution for internal temperature. Because this is the differential configuration, both the internal reference and offset capacitors are set to zero.

**Figure 14.4 Differential Input Capacitance Example**

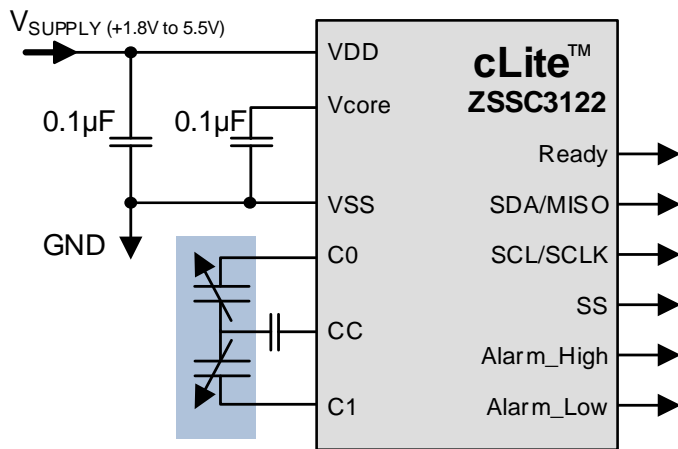

**Table 14.4 Example 4: Configuration Settings**

Configuration Register	15	14	13	12	11	10	9	8	7	6	5	4	3	2	1	0
ZMDI_Config (Table 12.2)	0 [a]	0	0	1	1	0	0	0	0	1	1	X	X	0	0	0
Cust_Config (Table 12.5)	0 [a]	0 [a]	0	0	1	0	0	0	0	0	1	0	1	0	0	0
C_Config (Table 12.3)	0 [a]	1	0	0	1	1	0 [a]	0 [a]	0 [a]	0 [a]	0	0	0	0	0	0
T_Config (Table 12.4)	1 [a]	0 [a]	0 [a]	0 [a]	0	1	0 [a]	1 [b]	1 [b]	0 [b]	0 [b]	1 [b]	0 [b]	0 [b]	1 [b]	0 [b]

[a] Reserved setting – do not change factory settings.

[b] The factory settings are set for a full span temperature range from -20°C to +125°C. Do not change this setting unless a different temperature range is needed.

### 14.5 External Reference Capacitor

This example demonstrates that the full functionality of the ZSSC3122, including the applications illustrated in examples 1, 2, and 3, can be implemented with an external reference capacitor in conjunction with a single-ended input capacitance. In this example, the digital output is used. The external reference is used. The configuration settings are shown in Table 14.5.

Example configuration settings show I2C in Sleep Mode with the Comm\_lock off so that the ZSSC3122 can respond to any I2C slave address. Also the Ready pin is configured for open drain so that the Ready lines for multiple devices can be connected together.

The AFE configuration registers select 12-bit resolution for capacitance and 12-bit resolution for internal temperature. This example also shows an offset setting of 4.3pF.

**Figure 14.5 Ext. Reference Input Capacitance Example**

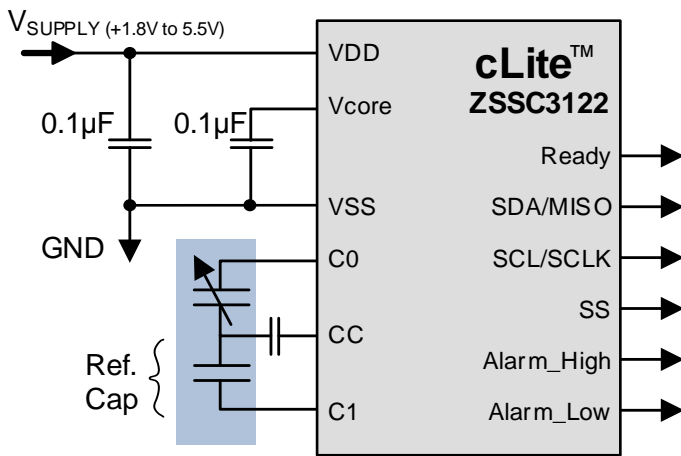

**Table 14.5 Example 5: Configuration Settings**

Configuration Register	15	14	13	12	11	10	9	8	7	6	5	4	3	2	1	0
ZMDI_Config (Table 12.2)	0 [a]	0	0	0	1	0	0	0	0	0	0	X	X	0	0	0
Cust_Config (Table 12.5)	0 [a]	0 [a]	0	1	0	0	0	0	0	0	1	0	1	0	0	0
C_Config (Table 12.3)	0 [a]	0	0	0	1	0	0 [a]	0 [a]	0 [a]	0 [a]	0	1	1	0	0	0
T_Config (Table 12.4)	1 [a]	0 [a]	0 [a]	0 [a]	1	0	0 [a]	1 [b]	1 [b]	0 [b]	0 [b]	1 [b]	0 [b]	0 [b]	1 [b]	0 [b]

[a] Reserved setting – do not change factory settings.

[b] The factory settings are set for a full span temperature range from -20°C to +125°C. Do not change this setting unless a different temperature range is needed.

## **15. ESD/Latch-Up-Protection**

All external module pins have an ESD protection of >4000V and a latch-up protection of  $\pm 100\text{mA}$  or (up to +8V / down to -4V) relative to VSS/VSSA. The internal module pin VCORE has an ESD protection of > 2000V. ESD protection referenced to the Human Body Model is tested with devices in TSSOP14 packages during product qualification. The ESD test follows the Human Body Model with 1.5kOhm/100pF based on MIL 883, Method 3015.7.

## **16. Test**

The test program is based on this datasheet. The final parameters, which are tested during production, are listed in the tables and graphs of section 1.

## **17. Reliability**

A reliability investigation according to the in-house non-automotive standard will be performed.

## **18. Customization**

For high-volume applications that require an upgraded or downgraded functionality compared to the ZSSC3122, IDT can customize the circuit design by adding or removing certain functional blocks.

For this customization, IDT has a considerable library of sensor-dedicated circuitry blocks, which enable IDT to provide a custom solution quickly. Please contact IDT for further information.

## 19. Package Outline Drawings

The package outline drawings are appended at the end of this document and are accessible from the link below. The package information is the most current data available.

<https://www.idt.com/document/psc/14-tssop-package-outline-drawing-44mm-body-065mm-pitch-pgg14t1>

## 20. Example Marking Diagram for TSSOP14 Parts

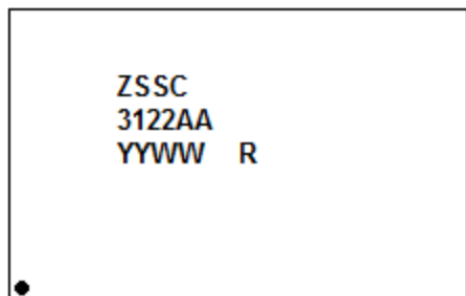

Line1: Partial part number.

Line 2: Next characters in the partial part number. Refer to section 23 for the available part code variations.

Line 3: “YYWW” represents the last two digits of the year followed by two digits for the work week that the part was assembled. “R” indicates “RoHS compliant.”

## 21. Storage and Soldering Conditions

**Table 21.1 TSSOP14 Storage and Soldering Conditions**

Parameter	Symbol	Conditions	Min	Typ	Max	Units
Maximum Storage Temperature	$T_{\text{max\_storage}}$	Less than 10hrs, before mounting			150	°C
Minimum Storage Temperature	$T_{\text{min\_storage}}$	At original packing only	-55			°C
Maximum Drybake Temperature	$T_{\text{drybake}}$	Less than 100hrs total, before mounting			125	°C
Soldering Peak Temperature	$T_{\text{peak}}$	Less than 30s (IPC/JEDEC-STD-020 Standard)			260	°C

## 22. Glossary

Term	Description
ADC	Analog-to-Digital Converter
CDC	Capacitance-to-Digital Converter
DAC	Digital-to-Analog Converter
ECC	Error Checking and Correction
SSC	Sensor Signal Conditioner

## 23. Ordering Information

Note: Contact IDT Sales for additional information and for sales and support for the ZSSC3122 Mass Calibration System.

Orderable Part Number	Description and Package	MSL Rating	Carrier Type	Temperature
ZSSC3122AA1BN	ZSSC3122 Die: Tested dice on un-sawn wafer, wafer thickness: 370µm	N/A	Wafer	-20°C to +125°C
ZSSC3122AI1BN	ZSSC3122 Die: Tested dice on un-sawn wafer, wafer thickness: 370µm	N/A	Wafer	-20°C to +85°C
ZSSC3122AI3BN	ZSSC3122 Die: Tested dice on un-sawn wafer, wafer thickness: 725µm	N/A	Wafer	-20°C to +85°C
ZSSC3122AA3BN	ZSSC3122 Die: Tested dice on un-sawn wafer, wafer thickness: 725µm	N/A	Wafer	-20°C to +125°C
ZSSC3122AA1CN	ZSSC3122 Die: Tested dice on frame, wafer thickness: 370µm	N/A	Wafer	-20°C to +125°C
ZSSC3122AI1CN	ZSSC3122 Die: Tested dice on frame, wafer thickness: 370µm	N/A	Wafer	-20°C to +85°C
ZSSC3122AA2RN	ZSSC3122 TSSOP14, lead-free package (PGG14T1)	1	Reel	-20°C to +125°C
ZSSC3122AA2TN	ZSSC3122 TSSOP14, lead-free package (PGG14T1)	1	Tube	-20°C to +125°C
ZSSC3122AI2RN	ZSSC3122 TSSOP14, lead-free package (PGG14T1)	1	Reel	-20°C to +85°C
ZSSC3122AI2TN	ZSSC3122 TSSOP14, lead-free package (PGG14T1)	1	Tube	-20°C to +85°C
ZSSC312223KITV1P0	ZSSC3122 SSC Evaluation Kit: Communication Board, SSC Board, Sensor Replacement Board, USB Cable, 5 IC Samples (Software can be downloaded from <a href="http://www.IDT.com/ZSSC3122">www.IDT.com/ZSSC3122</a> )			

## 24. Document Revision History

Date	Description
June 8, 2018	<ul style="list-style-type: none"> <li>▪ Update for template, including reorganization of sections.</li> <li>▪ Removal of related documents section. Visit <a href="http://www.IDT.com/zssc3122">www.IDT.com/zssc3122</a> for related documents.</li> <li>▪ Removal of references to ZSSC3122 <i>Technical Note—Detailed Equations for ZSSC3122 Rev C Silicon Math</i>.</li> <li>▪ Correction for kit order code.</li> <li>▪ Update for automatic web appending of the package outline drawing (POD). The POD is now located at the end of the document.</li> <li>▪ Addition of the moisture sensitivity levels to the part order information table.</li> <li>▪ Addition of the marking diagram description.</li> <li>▪ Minor edits.</li> </ul>
January 25, 2016	Changed to IDT branding. The release date is now the revision reference.
August 28, 2014 (Rev. 1.62)	Minor edit regarding die information on page 2.
June 13, 2014 (Rev. 1.61)	Addition of ZSSC3122AA3BN part number in section 19 and on page 3.



Date	Description
May 16, 2014 (Rev. 1.60)	<ul style="list-style-type: none"> <li>▪ Revised specifications for lower temperature range of -20°C to 125°C in section 1.2 and in data sheet text.</li> <li>▪ Revised specifications for upper internal clock frequency limit in section 1.3.</li> <li>▪ Revised specification for PDM frequency in section 3.7.</li> <li>▪ Revised part ordering codes.</li> </ul>
December 11, 2013 (Rev. 1.52)	<ul style="list-style-type: none"> <li>▪ Update to kit description in the part order tables: software is no longer included in kit. Instead it is downloaded from the product page <a href="http://www.IDT.com/ZSSC3122">www.IDT.com/ZSSC3122</a>.</li> <li>▪ Minor edits to refer to product by alphanumeric name ZSSC3122, rather than cLite™.</li> </ul>
July 4, 2013 (Rev. 1.51)	Update for part order codes.
May 22, 2013 (Rev. 1.50)	<ul style="list-style-type: none"> <li>▪ Revisions to section 10.3.2.1 to explain preferred method for detecting valid data.</li> <li>▪ Revision to section 10.6.6 to update Ready pin behavior in Sleep Mode.</li> <li>▪ Revision to Figure 10.7.</li> </ul>
July 23, 2012 (Rev. 1.40)	<ul style="list-style-type: none"> <li>▪ Added note for clarity to “Active Regulated Voltage” specification in section 5.</li> <li>▪ Deleted redundant specification for fOSC in section 5.</li> <li>▪ Revised specifications for CVCORE_SM and CVCORE_UM in specifications in section 4.</li> <li>▪ Updated IDT contact information.</li> </ul>
April 30, 2012 (Rev.1.30 )	<ul style="list-style-type: none"> <li>▪ Update for part numbers.</li> <li>▪ Update for contact information.</li> </ul>
August 16, 2011 (Rev. 1.20)	<ul style="list-style-type: none"> <li>▪ Added specifications in section 5 for VPOR maximum, VREG typical and maximum, and PSRTEMP.</li> <li>▪ Revisions to section 10.3.2.1 to explain preferred method for detecting valid data.</li> <li>▪ Revised product ordering codes.</li> </ul>
June 29, 2011 (Rev. 1.10)	<ul style="list-style-type: none"> <li>▪ Added specification for “Excitation Frequency of External Capacitances C0 and C1” in section 5 and 9.2.1.</li> <li>▪ Added “PDM frequency” specification to table in section 5. In section 10.7, clarified that clipping limit default values must be adjusted for PDM output functionality. Revised PDM frequency in sections 5 and 10.7. Revised PDM ripple and settling time specifications in section 5. Revised related examples in Table 10.12 and corrected equation (14) for calculating ripple. Revisions to text explaining equation (16) and subsequent text recommending limits for PDM_Clip_High. Revised Table 12.1 for PDM_Clip_High and PDM_Clip_Low. Added new settings for PDM clipping limits to section 14.2 and revised related settings in Table 14.2.</li> <li>▪ Revised section 8 for addition of specifications for “Voltage Dependency” for the temperature channel to section 5.</li> <li>▪ Revised section 9.2.1.3 regarding total capacitance.</li> <li>▪ Revised default value for EEPROM word 04HEX from 007THEX to 00FTHEX in Table 12.1.</li> <li>▪ Minor edits for clarity in section 14.3.</li> <li>▪ Revised notes for VCORE pin 1 in Table 2.1.</li> <li>▪ Revisions to section 10.3.2.1.</li> </ul>
February 15, 2011 (Rev. 1.00)	First release.



## IMPORTANT NOTICE AND DISCLAIMER

RENESAS ELECTRONICS CORPORATION AND ITS SUBSIDIARIES (“RENESAS”) PROVIDES TECHNICAL SPECIFICATIONS AND RELIABILITY DATA (INCLUDING DATASHEETS), DESIGN RESOURCES (INCLUDING REFERENCE DESIGNS), APPLICATION OR OTHER DESIGN ADVICE, WEB TOOLS, SAFETY INFORMATION, AND OTHER RESOURCES “AS IS” AND WITH ALL FAULTS, AND DISCLAIMS ALL WARRANTIES, EXPRESS OR IMPLIED, INCLUDING, WITHOUT LIMITATION, ANY IMPLIED WARRANTIES OF MERCHANTABILITY, FITNESS FOR A PARTICULAR PURPOSE, OR NON-INFRINGEMENT OF THIRD-PARTY INTELLECTUAL PROPERTY RIGHTS.

These resources are intended for developers who are designing with Renesas products. You are solely responsible for (1) selecting the appropriate products for your application, (2) designing, validating, and testing your application, and (3) ensuring your application meets applicable standards, and any other safety, security, or other requirements. These resources are subject to change without notice. Renesas grants you permission to use these resources only to develop an application that uses Renesas products. Other reproduction or use of these resources is strictly prohibited. No license is granted to any other Renesas intellectual property or to any third-party intellectual property. Renesas disclaims responsibility for, and you will fully indemnify Renesas and its representatives against, any claims, damages, costs, losses, or liabilities arising from your use of these resources. Renesas' products are provided only subject to Renesas' Terms and Conditions of Sale or other applicable terms agreed to in writing. No use of any Renesas resources expands or otherwise alters any applicable warranties or warranty disclaimers for these products.

(Disclaimer Rev.1.01 Jan 2024)

### Corporate Headquarters

TOYOSU FORESIA, 3-2-24 Toyosu,  
Koto-ku, Tokyo 135-0061, Japan  
[www.renesas.com](http://www.renesas.com)

### Trademarks

Renesas and the Renesas logo are trademarks of Renesas Electronics Corporation. All trademarks and registered trademarks are the property of their respective owners.

### Contact Information

For further information on a product, technology, the most up-to-date version of a document, or your nearest sales office, please visit [www.renesas.com/contact-us/](http://www.renesas.com/contact-us/).