

Brief Description

The ZSSC3135 is a member of the ZSSC313x family of CMOS integrated circuits designed for automotive/industrial sensor applications. All family members are well suited for highly accurate amplification and sensor-specific correction of resistive bridge sensor signals. An internal 16-bit RISC microcontroller running a correction algorithm compensates sensor offset, sensitivity, temperature drift, and non-linearity of the connected sensor element. The required calibration coefficients are stored by the one-pass calibration procedure in an on-chip EEPROM.

The ZSSC3135 is specially designed for piezoresistive bridge sensor elements. The amplification stage with an analog gain of 105 in combination with optional temperature compensation via an external temperature sensor meets or exceeds the requirements of piezoresistive sensor applications.

Features

- Adjustable to nearly all resistive bridge sensor types: analog gain of up to 105, maximum overall gain of 420
- Sample rate up to 200 Hz
- ADC resolution 13/14 bit
- Safety functionality sensor connection
- External temperature sensor
- Digital compensation of sensor offset, sensitivity, temperature drift, and non-linearity
- Output options: ratiometric analog voltage output (5 - 95% maximum, 12.4 bit resolution) or ZACwire™ (digital One-Wire Interface (OWI))
- Sensor biasing by voltage
- High voltage protection up to 33 V
- Supply current: max. 5.5mA
- Reverse polarity and short circuit protection
- Wide operation temperature range: -40 to +150°C
- Traceability by user-defined EEPROM entries

* Note: I²C™ is a trademark of NXP.

** FSO = Full Scale Output.

Benefits

- Family approach offers the best fitting IC selection to build cost-optimized applications
- No external trimming components required
- Low number of external components needed
- PC-controlled configuration and one-pass/end-of-line calibration via I²C™* or ZACwire™ interface: simple, cost-efficient, quick, and precise
- High accuracy: 0.25% FSO** @ -25 to +85°C; 0.5% FSO @ -40 to +125°C
- Optimized for automotive/industrial environments due to robust protection circuitries, excellent electromagnetic compatibility and AEC-Q100 qualification

Available Support

- Evaluation Kits
- Application Notes
- Mass Calibration System

Physical Characteristics

- Supply voltage: 4.5 to 5.5 V
- Operation temperature: -40°C to +125°C (-40°C to +150°C extended temperature range depending on product version)
- Available in RoHS-compliant JEDEC-SSOP14 package or delivery as die

ZSSC3135 Minimum Application Requirements

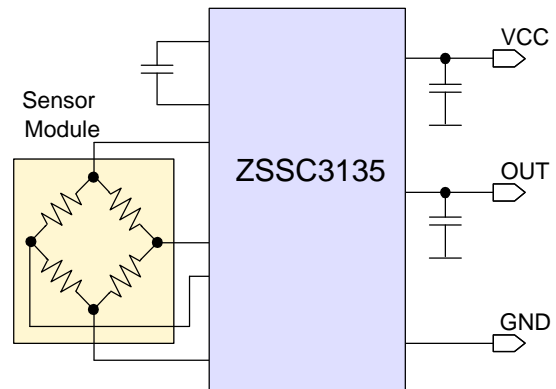

ZSSC3135 Application Example

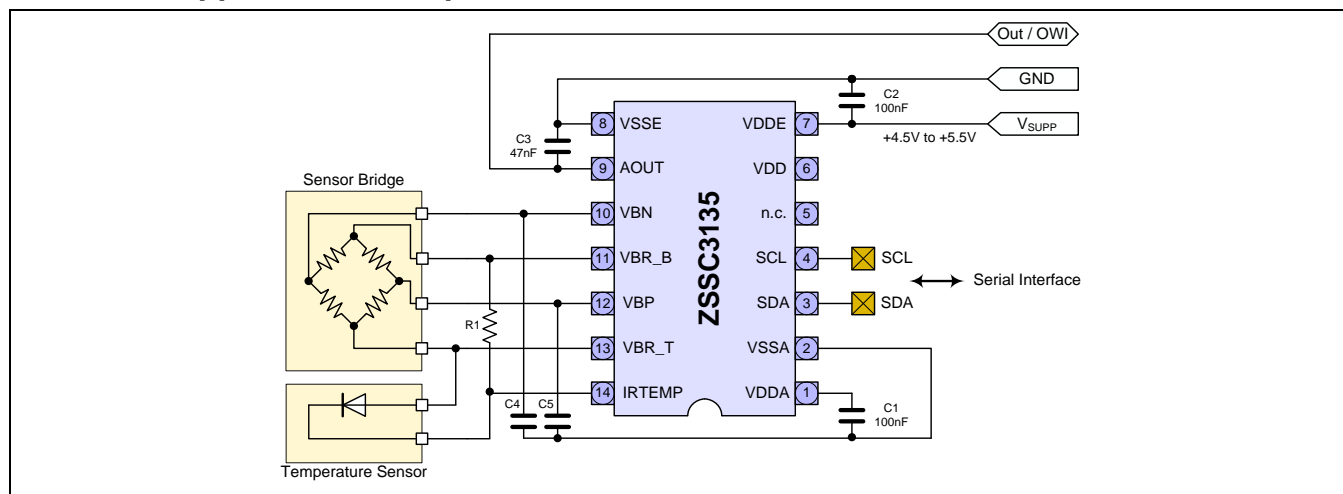

Ordering Information (See data sheet section 8 for complete delivery options.)

Product Sales Code	Description	Package
ZSSC3135BE1	ZSSC3135 die – tested; temperature range -40 to +150°C	Unsaun wafer: add “B” to sales code Die on frame: add “C” to sales code
ZSSC3135BA1	ZSSC3135 die – tested; temperature range -40 to +125°C	Unsaun wafer: add “B” to sales code Die on frame: add “C” to sales code
ZSSC3135BE2	ZSSC3135 SSOP14 – temperature range -40 to +150°C	Tube: add “T” to sales code Tape & Reel: add “R”
ZSSC3135BA2	ZSSC3135 SSOP14 – temperature range -40 to +125°C	Tube: add “T” to sales code Tape & Reel: add “R”
ZSSC313xKITV1.1	ZSSC313x Evaluation Kit, revision 1.1 including Evaluation Board, ZSSC3135 IC samples, USB cable (software can be downloaded from the product page www.IDT.com/ZSSC3135)	Kit
ZSSC313x Mass Calibration System V1.1	Modular Mass Calibration System (MSC) for ZSSC313x including MCS boards, cable, connectors (software can be downloaded from the product page www.IDT.com/ZSSC3135)	Kit

Contents

1	Electrical Characteristics	5
1.1.	Absolute Maximum Ratings	5
1.2.	Operating Conditions	5
1.3.	Electrical Parameters	6
1.3.1.	Supply Current and System Operation Conditions	6
1.3.2.	Analog Front-End (AFE) Characteristics	6
1.3.3.	Temperature Measurement ²⁾	6
1.3.4.	A/D Conversion	7
1.3.5.	Sensor Check	7
1.3.6.	DAC and Analog Output	7
1.3.7.	System Response	8
1.4.	Interface Characteristics and EEPROM	9
1.4.1.	I ² C TM Interface ¹⁾	9
1.4.2.	ZACwire TM One-Wire Interface (OWI) ¹⁾	9
1.4.3.	EEPROM	9
2	Circuit Description	10
2.1.	Signal Flow	10
2.2.	Application Modes	11
2.3.	Analog Front-End (AFE)	11
2.3.1.	Programmable Gain Amplifier (PGA)	11
2.3.2.	Offset Compensation	12
2.3.3.	Measurement Cycle	12
2.3.4.	Analog-to-Digital Converter	13
2.4.	Temperature Measurement	14
2.5.	System Control and Conditioning Calculation	14
2.5.1.	General Working Modes	14
2.5.2.	Startup Phase	14
2.5.3.	Conditioning Calculation	15
2.6.	Analog or Digital Output	15
2.7.	Serial Digital Interface	16
2.8.	Failsafe Features	16
2.9.	High Voltage, Reverse Polarity, and Short Circuit Protection	16
3	Application Circuit Examples	17
4	Pin Configuration and Package	19
5	ESD Protection	20
6	Quality and Reliability	20
7	Customization	20
8	Ordering Information	20
9	Related Documents	21

10	Glossary	21
11	Document Revision History	23

List of Figures

Figure 2.1	Block Diagram of the ZSSC3135.....	10
Figure 2.2	Measurement Cycle with 1 Bridge Sensor Signal Measurement per Special Measurement.....	12
Figure 3.1	Application with On-Chip Diode Temperature Sensor.....	17
Figure 3.2	Application with External Diode Temperature Sensor	18
Figure 3.3	Application with External Thermistor	18
Figure 4.1	ZSSC3135 SSOP14 Pin Diagram	19

List of Tables

Table 1.1	Absolute Maximum Ratings	5
Table 1.2	Operating Conditions	5
Table 1.3	Electrical Parameters.....	6
Table 1.4	Interface Characteristics and EEPROM	9
Table 2.1	Adjustable Gains, Resulting Sensor Signal Spans and Common Mode Ranges	11
Table 2.2	ADC Resolution versus Output Resolution and Sample Rate.....	14
Table 3.1	External Components for Application Circuit Examples	17
Table 4.1	Pin Configuration and Definition	19

1 Electrical Characteristics

1.1. Absolute Maximum Ratings

Note: The absolute maximum ratings are stress ratings only. The device might not function or be operable above the operating conditions given in section 1.2. Stresses exceeding the absolute maximum ratings might also damage the device. In addition, extended exposure to stresses above the recommended operating conditions might affect device reliability. IDT does not recommend designing to the “Absolute Maximum Ratings.”

Parameters apply in operation temperature range and without time limitations.

Table 1.1 Absolute Maximum Ratings

No.	Parameter	Symbol	Conditions	Min	Max	Unit
1.1.1	Supply voltage ¹⁾	VDDE _{AMR}	To VSSE, refer to section 3 for application circuits	-33	33	VDC
1.1.2	Potential at AOUT pin ¹⁾	V _{OUT}	Referenced to VSSE	-33	33	VDC
1.1.3	Analog supply voltage ¹⁾	VDDA _{AMR}	Referenced to VSSA, VDDE - VDDA < 0.35V	-0.3	6.5	VDC
1.1.4	Voltage at all analog and digital IO pins	V _{A_IO} V _{D_IO}	Referenced to VSSA	-0.3	VDDA + 0.3	VDC
1.1.5	Storage temperature	T _{STG}		-55	150	°C

¹⁾ Refer to the ZSSC313x High Voltage Protection Description for specification and detailed conditions.

1.2. Operating Conditions

All voltages are referenced to VSSA.

Table 1.2 Operating Conditions

No.	Parameter	Symbol	Conditions	Min	Typ	Max	Unit
1.2.1	Ambient temperature ^{1) 2)}	T _{AMB_TQE}	Extended Temperature Range (TQE)	-40		150	°C
		T _{AMB_TQA}	Advanced-Performance Temperature Range (TQA)	-40		125	°C
		T _{AMB_TQI}	Best-Performance Temperature Range (TQI)	-25		85	°C
1.2.2	Supply voltage	VDDE		4.5	5.0	5.5	VDC
1.2.3	Bridge resistance ^{3) 4)}	R _{BR}		2		25	kΩ

1) Maximum operation temperature range depends on product version (refer to section 8).
 2) See the temperature profile description in the ZSSC313x Technical Note—Die & Package Dimensions.
 3) No measurement in mass production; parameter is guaranteed by design and/or quality observation.
 4) Symmetric behavior and identical electrical properties (especially the low pass characteristic) of both sensor inputs of the ZSSC3135 are required. Unsymmetrical conditions of the sensor and/or external components connected to the sensor input pins of the ZSSC3135 can generate a failure in signal operation.

1.3. Electrical Parameters

All parameter values are valid under the operating conditions specified in section 1.2 (special definitions excluded). All voltages referenced to VSSA.

Note: See important notes at the end of Table 1.3.

Table 1.3 Electrical Parameters

No.	Parameter	Symbol	Conditions	Min	Typ	Max	Unit
1.3.1. Supply Current and System Operation Conditions							
1.3.1.1	Supply current	I_S	Without bridge and load current, $f_{OSC} \leq 3$ MHz			5.5	mA
1.3.1.2	Oscillator frequency ¹⁾	f_{OSC}	Adjustment guaranteed for full temperature range (T_{AMB_TQE})	2	3	4	MHz
1.3.2. Analog Front-End (AFE) Characteristics							
1.3.2.1	Input span	V_{IN_SP}	Analog gain: 105 to 2.8	8		275	mV/V
1.3.2.2	Parasitic differential input offset current ¹⁾	I_{IN_OFF}	Temperature range T_{AMB_TQE}	-10		10	nA
			Temperature range T_{AMB_TQI}	-2		2	nA
1.3.2.3	Common mode input range	V_{IN_CM}	Depends on gain adjustment; see section 2.3.1	0.29		0.65	VDDA
1.3.3. Temperature Measurement ²⁾							
1.3.3.1	Internal temperature diode sensitivity	ST_{TSI}	Raw values, without conditioning	700		2700	ppm FS / K
1.3.3.2	External temperature diode channel gain	AT_{SED}		300		1300	ppm FS / (mV/V)
1.3.3.3	External temperature diode bias current	IT_{SED}		6	10	20	μ A
1.3.3.4	External temperature diode input range ¹⁾	V_{TSED}		0		1.5	V
1.3.3.5	External temperature resistor channel gain	AT_{SER}		1200		3500	ppm FS / (mV/V)
1.3.3.6	External temperature resistor input range ¹⁾	V_{TSER}		0		600	mV/V

No.	Parameter	Symbol	Conditions	Min	Typ	Max	Unit
1.3.4. A/D Conversion							
1.3.4.1	A/D resolution ¹⁾	r _{ADC}		13		14	Bit
1.3.4.2	DNL ¹⁾	DNL _{ADC}	r _{ADC} =13bit, f _{OSC} =3MHz, best fit, complete AFE, range according to 1.3.4.5			0.95	LSB
1.3.4.3	INL TQA	INL _{ADC}	r _{ADC} =13bit, f _{OSC} =3MHz, best fit, complete AFE, range according to 1.3.4.5			4	LSB
1.3.4.4	INL TQE	INL _{ADC_TQE}	r _{ADC} =13bit, f _{OSC} =3MHz, best fit, complete AFE, range according to 1.3.4.5, temperature range T _{AMB_TQE}			5	LSB
1.3.4.5	ADC input range	V _{ADC_IN}		0.1		0.9	VDDA
1.3.5. Sensor Check							
1.3.5.1	Sensor connection loss	R _{SSC_min}	Detection threshold	100			kΩ
1.3.5.2	Sensor input short	R _{SSC_short}	Short detection guaranteed	0		50	Ω
1.3.5.3	Sensor input no short	R _{SSC_pass}	Corresponds with minimum sensor output resistance	1000			Ω
1.3.6. DAC and Analog Output							
1.3.6.1	D/A resolution	r _{DAC}	Analog output, 10-90%		12		Bit
1.3.6.2	Output current sink and source for VDDE=5V	I _{OUT_SRC/SINK}	V _{OUT} : 5-95%, R _{LOAD} ≥ 2kΩ			2.5	mA
			V _{OUT} : 10-90%, R _{LOAD} ≥ 1kΩ			5	mA
1.3.6.3	Short circuit current	I _{OUT_max}	To VDDE or VSSE ³⁾	-25		25	mA
1.3.6.4	Output signal range	V _{OUT_RANGE}	With R _{LOAD} ≥ 2kΩ	0.05		0.95	VDDE
			With R _{LOAD} ≥ 1kΩ	0.1		0.90	VDDE
1.3.6.5	Output slew rate ¹⁾	SR _{OUT}	C _{LOAD} < 50nF	0.1			V/μs
1.3.6.6	Output resistance in diagnostic mode	R _{OUT_DM}	Diagnostic range: <4 to 96>%, R _{LOAD} ≥ 2kΩ <8 to 92>%, R _{LOAD} ≥ 1kΩ			82	Ω
1.3.6.7	Load capacitance ¹⁾	C _{LOAD}	C3 + C _{LOAD} (refer to section 3)			150	nF
1.3.6.8	DNL	DNL _{OUT}		-1.5		1.5	LSB
1.3.6.9	INL TQA	INL _{OUT}	Best fit, r _{DAC} =12bit	-5		5	LSB
1.3.6.10	INL TQE	INL _{OUT_TQE}	Best fit, r _{DAC} =12bit, temperature range T _{AMB_TQE}	-8		8	LSB
1.3.6.11	Output leakage current at 150°C	I _{OUT_LEAK}	In case of power or ground loss	-25		25	μA

No.	Parameter	Symbol	Conditions	Min	Typ	Max	Unit
1.3.7. System Response							
1.3.7.1	Startup time ^{1) 4)} (To 1 st output, ROM check disabled)	t _{STARTUP}	1-step ADC, f _{OSC} =3MHz r _{ADC} =14bit)			35	ms
1.3.7.2	Response time ¹⁾ (100% input step; refer to Table 2.2)	t _{RESPONSE}	1-step ADC, f _{OSC} =4MHz, r _{ADC} =13bit	8.7	13.1	17.4	ms
1.3.7.3	Bandwidth ¹⁾ (In comparison to an equivalent analog SSC. Refer to Table 2.2)	BW	1-step ADC			200	Hz
1.3.7.4	Analog output noise peak-to-peak ¹⁾	V _{NOISE_PP}	Shorted inputs bandwidth ≤ 10kHz			10	mV
1.3.7.5	Analog output noise RMS ¹⁾	V _{NOISE_RMS}	Shorted inputs bandwidth ≤ 10kHz			3	mV
1.3.7.6	Ratiometricity error	RE	Maximum error for VDDE=5V to 4.5/5.5V			1000	ppm
1.3.7.7	Overall failure Deviation from ideal line including INL, gain, offset and temperature errors. No sensor-caused effects. Failure for digital readout shown in parenthesis.	F _{OVERALL_TQI}	f _{OSC} ≤3MHz, r _{ADC} =13bit, temperature range T _{AMB_TQI}		0.25 (0.1)		% FS
		F _{OVERALL_TQA}	f _{OSC} ≤3MHz, r _{ADC} =13bit, temperature range T _{AMB_TQA}		0.5 (0.25)		% FS
		F _{OVERALL_TQE}	f _{OSC} ≤3MHz, r _{ADC} =13bit, temperature range T _{AMB_TQE}		1.0 (0.5)		% FS
1) No measurement in mass production; parameter is guaranteed by design and/or quality observation. 2) Refer to section 2.4 for important details. 3) Minimum output voltage to VDDE or maximum output voltage to VSSE. 4) Depends on resolution and configuration. Start routine begins approximately 0.8ms after power on.							

1.4. Interface Characteristics and EEPROM

Table 1.4 Interface Characteristics and EEPROM

No.	Parameter	Symbol	Conditions	Min	Typ	Max	Unit
1.4.1. I²C™ Interface ¹⁾							
1.4.1.1	I ² C™ voltage level HIGH	V _{I²C,HIGH}		0.8			VDDA
1.4.1.2	I ² C™ voltage level LOW ²⁾	V _{I²C,LOW}				0.2	VDDA
1.4.1.3	Slave output level LOW ²⁾	V _{I²C,LOW_OUT}	Open drain, I _{OL} <2mA			0.15	VDDA
1.4.1.4	SDA load capacitance ²⁾	C _{SDA}				400	pF
1.4.1.5	SCL clock frequency ²⁾	f _{I²C}	f _{OSC} ≥2MHz			400	kHz
1.4.1.6	Internal pull-up resistor ²⁾	R _{I²C,PULLUP}		25		100	kΩ
1.4.2. ZACwire™ One-Wire Interface (OWI) ¹⁾							
1.4.2.1	OWI voltage level HIGH ²⁾	V _{OWI,HIGH}		0.75			VDDA
1.4.2.2	OWI voltage level LOW ²⁾	V _{OWI,LOW}				0.2	VDDA
1.4.2.3	Slave output level LOW ²⁾	V _{OWI,LOW_OUT}	Open drain, I _{OL} <2mA			0.15	VDDA
1.4.2.4	Start window ²⁾	t _{OWI,STARTWIN}	At f _{OSC} =3MHz	96	175	455	ms
1.4.3. EEPROM							
1.4.3.1	Ambient temperature for EEPROM programming ²⁾	T _{AMB_EEP}		-40		150	°C
1.4.3.2	Write cycles ²⁾	n _{EEP_WRI}	Write ≤ 85°C			100 000	
			Write up to 150°C			100	
1.4.3.3	Read cycles ^{2) 3)}	n _{EEP_READ}	≤175°C			8 * 10 ⁸	
1.4.3.4	Data retention ^{2) 4)}	t _{EEP_RETENTION}	1300h at 175°C (= 3000h at 150°C + 27000h at 125°C + 100000h at 55°C)			15	a
1.4.3.5	Programming time ²⁾	t _{EEP_WRI}	Per written word		12		ms
1) Refer to the ZSSC313x <i>Functional Description</i> for timing details. 2) No measurement in mass production, parameter is guaranteed by design and/or quality observation. 3) Valid for the dice. Note that the package and the temperature version cause additional restrictions. 4) Over lifetime and valid for the dice. Use the calculation sheet <i>IDT Temperature Profile Calculation Sheet</i> for temperature stress calculation. Note that the package and the temperature version cause additional restrictions.							

2 Circuit Description

2.1. Signal Flow

The ZSSC3135's signal path is partly analog and partly digital. The analog section is differential – this means the differential bridge sensor signal is internally handled via two signal lines that are rejected symmetrically around an internal common mode potential (analog ground = $V_{DDA}/2$).

As a result of the differential design, it is possible to amplify positive and negative input signals that are within the common mode range of the signal input.

Figure 2.1 Block Diagram of the ZSSC3135

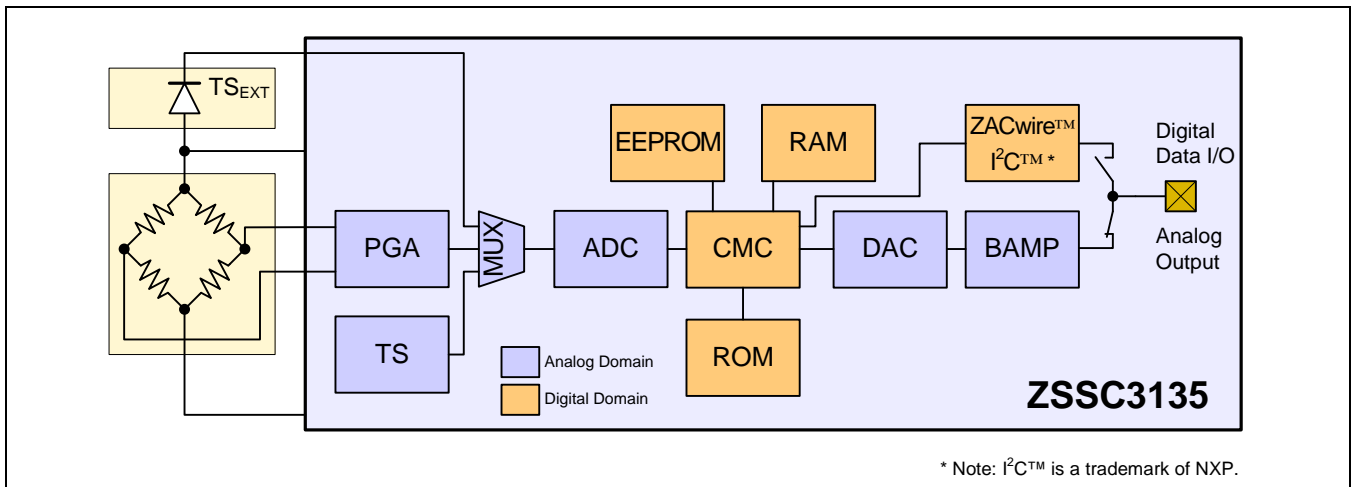

PGA	Programmable Gain Amplifier
TS	On-Chip Temperature Sensor (pn-junction)
TS _{EXT}	External Temperature Sensor (pn-junction)
MUX	Multiplexer
ADC	Analog-to-Digital Converter
CMC	Calibration Microcontroller
ROM	Read-Only Memory for Correction Formula and Algorithm
RAM	Volatile Memory for Calibration Parameters and Configuration
EEPROM	Non-volatile Memory for Calibration Parameters and Configuration
DAC	Digital-to-Analog Converter
BAMP	Output Buffer Amplifier

The differential signal from the bridge sensor is pre-amplified by the programmable gain amplifier (PGA). The multiplexer (MUX) transmits the signals from either the bridge sensor or the internal or external temperature sensor to the analog-to-digital converter (ADC) in a specific sequence. The ADC converts these signals into digital values.

The digital signal conditioning is processed by the calibration microcontroller (CMC). It is based on a correction formula that uses sensor-specific coefficients determined during calibration. The formula is located in ROM, and the sensor-specific coefficients are stored in EEPROM. Depending on the programmed output configuration, the conditioned sensor signal is output as an analog signal or alternatively can be readout via a digital serial interface (I²C™ or ZACwire™). The configuration data and the correction parameters must also be programmed into the EEPROM via the digital interfaces.

2.2. Application Modes

For each application, a configuration set must be established by programming the on-chip EEPROM for the following modes:

- Sensor channel
 - Input range: The gain adjustment of the analog front-end (AFE) with respect to the maximum sensor signal span and the zero point of the A/D conversion must be selected.
 - Resolution/response time: The A/D converter must be configured for resolution. These settings influence the sampling rate and the signal integration time, and thus, the noise immunity.
- Temperature
 - Temperature measurement: Select the internal or external temperature sensor.

2.3. Analog Front-End (AFE)

The analog front-end (AFE) consists of the three-stage programmable gain amplifier (PGA), the multiplexer (MUX), and the analog-to-digital converter (ADC).

2.3.1. Programmable Gain Amplifier (PGA)

Table 2.1 shows the adjustable gains, the sensor signal spans, and the valid common mode range.

Table 2.1 Adjustable Gains, Resulting Sensor Signal Spans and Common Mode Ranges

PGA Gain a_{IN}	Maximum Span V_{IN_SP} [mV/V] ¹⁾	Input Common Mode Range V_{IN_CM} [% VDDA]
105	7.1	29 to 65
70	10.7	29 to 65
52.5	14.3	29 to 65
35	21.4	29 to 65
26.3	28.5	29 to 65
14	53.75	29 to 65
9.3	80	29 to 65
7	107	29 to 65
2.8	267	32 to 57

1) Recommended maximum internal signal range is 75% of the supply voltage.
Span is calculated by the following formula: $Span = 0.75 (VBR_T - VBR_B) / Gain$.

2.3.2. Offset Compensation

The ZSSC3135 processes a sensor-offset correction during the digital signal conditioning by the calibration microcontroller (CMC).

2.3.3. Measurement Cycle

The measurement cycle is controlled by the CMC. Depending on EEPROM settings, the multiplexer (MUX) selects the following input signals in a defined sequence:

- Pre-amplified bridge sensor signal
- Temperature sensor signal
- Internal offset of the input channel (V_{OFF})

The cycle diagram in Figure 2.2 shows the basic structure of the measurement cycle. After power-on, the startup routine is processed, which performs all required measurements to expedite acquiring an initial valid conditioned sensor output. After the startup routine, the normal measurement cycle runs.

Figure 2.2 Measurement Cycle with 1 Bridge Sensor Signal Measurement per Special Measurement

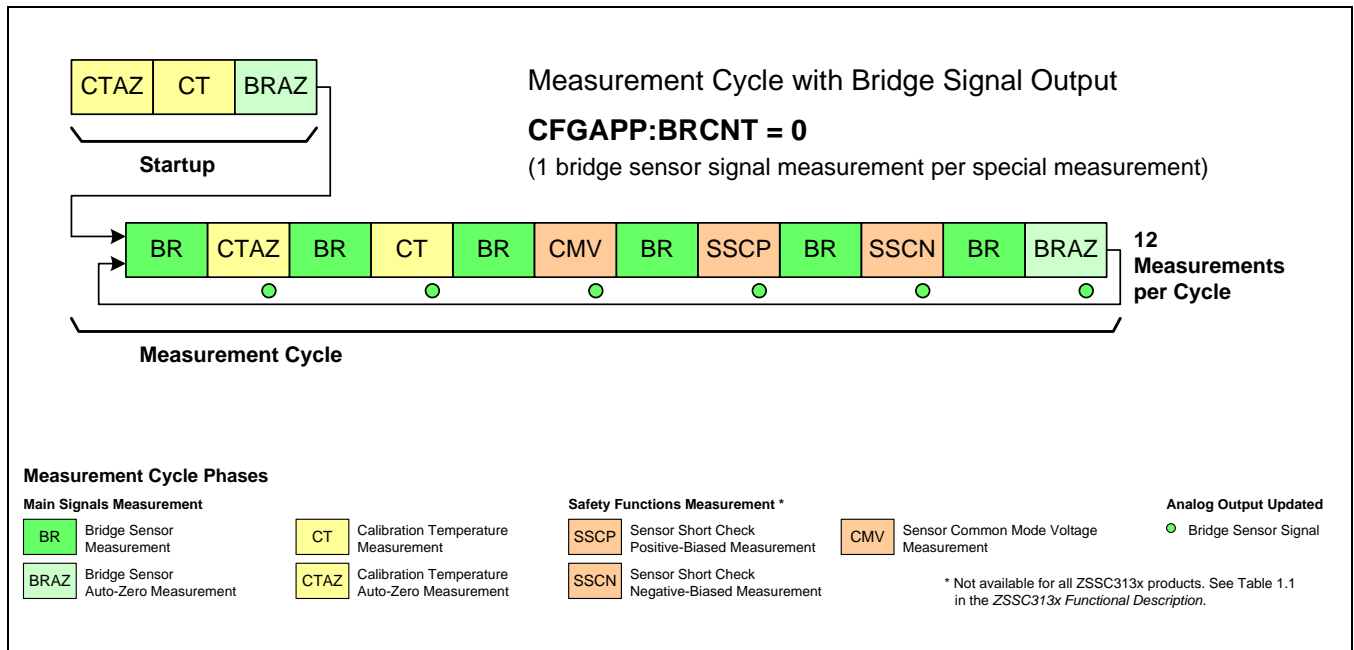

2.3.4. Analog-to-Digital Converter

The A/D converter is implemented using full-differential switched-capacitor technique.

Programmable ADC resolutions are $r_{ADC} = \langle 13, 14 \rangle$ bit.

The A/D conversion is integrating, inherently monotone, and insensitive to short and long term instability of the clock frequency. The conversion time t_{ADC} depends on the desired resolution and can be roughly calculated by equation (1):

$$t_{ADC} = \frac{2^{r_{ADC}}}{\left(\frac{f_{OSC}}{2}\right)} \quad (1)$$

Where

- r_{ADC} Resolution of A/D conversion
- f_{OSC} Frequency of internal oscillator (refer to 1.3.1)

Refer to the *ZSSC313x Bandwidth Calculation Sheet* for a detailed calculation of sampling time and bandwidth.

The result of the A/D conversion is a relative counter result Z corresponding to the following equation:

$$Z = 2^{r_{ADC}} \cdot \left(\frac{V_{ADC_DIFF}}{V_{ADC_REF}} - RS\right) \quad (2)$$

Where

- r_{ADC} Resolution of A/D conversion
- V_{ADC_DIFF} Differential ADC input voltage
- V_{ADC_REF} ADC reference voltage as selected by the BRREF bits in the EEPROM configuration word CFGAPP ($V_{VBR_T} - V_{VBR_B}$ if BRREF= 0) or ($V_{VDDA} - V_{VSSA}$ if BRREF=1) *
- RS Digital ADC Range Shift (RS = 1/16, 1/8, 1/4, or 1/2; controlled by the ADCRS bits in the EEPROM configuration word CFGAFE) *

With the RS value, a sensor input signal can be shifted in the optimal input range of the ADC.

The condition required for ensuring the specified accuracy, stability, and non-linearity parameters of the analog front-end is that the differential ADC input voltage V_{ADC_DIFF} does not exceed the range of 10% to 90% of the ADC reference voltage V_{ADC_REF} . This requirement must be met for the whole temperature range and for all sensor tolerances.

* Refer to the *ZSSC313x Functional Description* for more information on EEPROM contents.

Table 2.2 ADC Resolution versus Output Resolution and Sample Rate

ADC Adjustment	Output Resolution ¹⁾		Sample Rate ²⁾		Averaged Bandwidth ²⁾	
	r _{ADC} [bit]	Digital [bit]	Analog [bit]	f _{osc} =3MHz [Hz]	f _{osc} =4MHz [Hz]	f _{osc} =3MHz [Hz]
13	13	12	345	460	130	172
14	14	12	178	237	67	89

1) Output resolution does not exceed ADC resolution. PGA gain should be such that the differential ADC input signal uses at least 50% of the ADC input range to ensure maximum achievable output resolution.
 2) Refer to the ZSSC313x *Bandwidth Calculation Sheet* for a detailed calculation of sampling time and bandwidth.

2.4. Temperature Measurement

The ZSSC3135 supports different methods for acquiring temperature data needed for conditioning of the sensor signal. Temperature data can be acquired using

- an internal pn-junction temperature sensor,
- an external pn-junction temperature sensor connected to the sensor top potential (V_{BR_T}), or
- an external resistive half bridge temperature sensor.

Refer to the ZSSC313x *Functional Description* for a detailed explanation of temperature sensor adaptation and adjustment.

2.5. System Control and Conditioning Calculation

The system control supports the following tasks/features:

- Managing the startup sequence
- Controlling the measurement cycle regarding to the EEPROM-stored configuration data
- Sensor signal conditioning (calculation of the 16-bit correction for each measurement signal using the EEPROM-stored conditioning coefficients and the ROM-based formulas)
- Processing communication requests received via the digital interfaces
- Performing failsafe tasks and message detected errors by setting diagnostic states

2.5.1. General Working Modes

ZSSC3135 supports three different working modes:

- Normal Operation Mode (NOM) – for continuous processing of signal conditioning
- Command Mode (CM) – for calibration and access to all internal registers
- Diagnostic Mode (DM) – for failure messages

2.5.2. Startup Phase *

After power-on, the startup phase is processed, which includes

- Internal supply voltage settling including reset of the circuitry by the power-on reset block (POR). Refer to the ZSSC313x *High Voltage Protection Description* for power-on/off thresholds. Duration (beginning with V_{VDDA}-V_{VSSA}=0V): 500µs to 2ms; AOUT: high impedance.

* All timing values are roughly estimated for an oscillator frequency f_{osc}=3MHz and are proportional to that frequency.

- System start and configuration, EEPROM readout, and signature check.
Duration: ~200µs; AOUT: lower diagnostic range (LDR).
- Processing the measurement cycle start routine.
Duration: 5x A/D conversion time; AOUT behavior depends on configured one-wire communication mode (refer to section 2.6):
 - OWIANA or OWIDIS → AOUT: lower diagnostic range (LDR)
 - OWIWIN or OWIENA → AOUT: tri-state

If an error is detected during the startup phase, the Diagnostic Mode (DM) is activated and the analog output at the AOUT pin remains in the lower diagnostic range.

After the startup phase, the continuous running measurement and sensor signal conditioning cycle is started, and analog or digital output of the conditioned sensor signal is activated. If the one-wire communication mode OWIWIN is selected, the OWI startup window expires before analog output is available.

2.5.3. Conditioning Calculation

The digitalized value for the bridge signal is processed with a conditioning formula to remove offset and temperature dependency and to compensate nonlinearity up to 3rd order. The result is a non-negative 15-bit value for the measured bridge sensor signal in the range [0; 1). This value is available for readout via I²C™ or OWI communication. For the analog output, the value is clipped to the programmed output limits.

Note: The extent of signal deviation that can be compensated by the conditioning calculation depends on the specific sensor signal characteristics. For a rough estimation, assume the following: offset compensation and gain correction are not limited. Note that resolution of the digitally gained signal is determined by the ADC resolution in respect to the dynamic input range used. The temperature correction includes first and second order terms and should be adequate for practically all relevant cases. The non-linearity correction of the sensor signal is possible for second-order up to approximately 30% FS regarding ideal fit and for third-order up to about 20% FS. Overall, the conditioning formula applied is able to reduce the non-linearity of the sensor signal by a factor of 10.

2.6. Analog or Digital Output

The AOUT pin is used for analog output and for one-wire communication (OWI). The latter can be used for digital readout of the conditioned sensor signal and for end-of-line sensor module calibration. The ZSSC3135 supports different modes for the analog output in interaction with OWI communication as selected by EEPROM configuration or by command:

- OWIENA: Analog output is deactivated; OWI readout of the signal data is enabled.
- OWIWIN: Analog output starts after the startup phase and after the OWI startup window if OWI communication is not initiated; OWI communication for configuration or for end-of-line calibration can be started during the OWI startup window (maximum ~500ms) by sending the START_CM command.
- OWIANA: Analog output starts after the startup phase; OWI communication for configuration or for end-of-line calibration can be started during the OWI startup window (maximum ~500ms) by sending the START_CM command; for command transmission, the analog output driven at the AOUT pin must be overwritten by the external communication master (AOUT drive capability is current-limited).
- OWIDIS: Analog output starts after the startup phase; OWI readout of the signal data is disabled.

The analog output signal is driven by an offset compensated, rail-to-rail output buffer that is current-limited to prevent damage to the ZSSC3135 in the event of a short circuit between the analog output and power supply or ground. Output resolution of at least 12-bit in the range of 10% to 90% FS is ensured by a 12.4-bit resistor string DAC.

2.7. Serial Digital Interface

The ZSSC3135 includes a serial digital I²C™ interface and a ZACwire™ interface for one-wire communication (OWI). The digital interfaces allow configuration and calibration of the sensor module. OWI communication can be used to perform an end-of-line calibration via the analog output pin AOUT of a completely assembled sensor module. The interfaces also provide the readout of the conditioned sensor signal data during normal operation.

Refer to the *ZSSC313x Functional Description* for a detailed description of the serial interfaces and the communication protocols.

2.8. Failsafe Features

The ZSSC3135 detects various failures. When a failure is detected, Diagnostic Mode (DM) is activated. DM is indicated by setting the output pin AOUT to the Lower Diagnostic Range (LDR). When using digital serial communication protocols (I²C™ or OWI) to read conditioning results data, the error status is indicated by a specific error code.

A watchdog timer controls the proper operation of the microcontroller. The operation of the internal oscillator is monitored by an oscillator-failure detection circuit. EEPROM and RAM content are checked when accessed. Control registers are parity protected.

The sensor connection is checked with regard to broken wires or short circuits (sensor connection check, sensor short check).

The connection of an external temperature sensor can be monitored by the temperature sensor check.

Refer to the *ZSSC313x Functional Description* for a detailed description of failsafe features and methods of error indication.

2.9. High Voltage, Reverse Polarity, and Short Circuit Protection

The ZSSC3135 is designed for 5V power supply operation.

The ZSSC3135 and the connected sensor are protected from overvoltage and reverse polarity damage by an internal supply voltage limiter. The analog output AOUT can be connected (short circuit, overvoltage, and reverse polarity) with all potentials in the protection range under all potential conditions at the pins VDDE and VSSE.

To guarantee this operation, all external components (see application circuit in section 3) are required. The protection is not time-limited.

Refer to the *ZSSC313x High Voltage Protection Description* for a detailed description of protection cases and conditions.

3 Application Circuit Examples

The application circuits contain external components that are needed for overvoltage, reverse polarity, and short circuit protection.

Note: Also refer to *ZSSC313x Technical Note—EMC Design Guidelines* and other ZSSC313x application notes available on the ZSSC3135 product web page (www.IDT.com/zssc3135) for additional application examples and board layout recommendations.

Table 3.1 External Components for Application Circuit Examples

Symbol	Component	Min	Typ ²⁾	Max	Unit	Remarks
C1	Capacitor	100		470	nF	
C2	Capacitor	100			nF	
C3 ¹⁾	Capacitor	4	47	160	nF	Value includes the load capacitor C3 and the capacitance of the connection cable.
C4, C5 ¹⁾	Capacitor	0		10	nF	Recommended to increase EMI immunity. Value includes the filter capacitor C4 and C5 and the sensor connection line capacitance.
R1	Resistor		10		kΩ	See Figure 3.3 for location.

1) Increasing capacitors C3, C4, and C5 increases EMI immunity.
 2) Dimensioning is only for example and must be adapted to the requirements of the application.

Figure 3.1 Application with On-Chip Diode Temperature Sensor

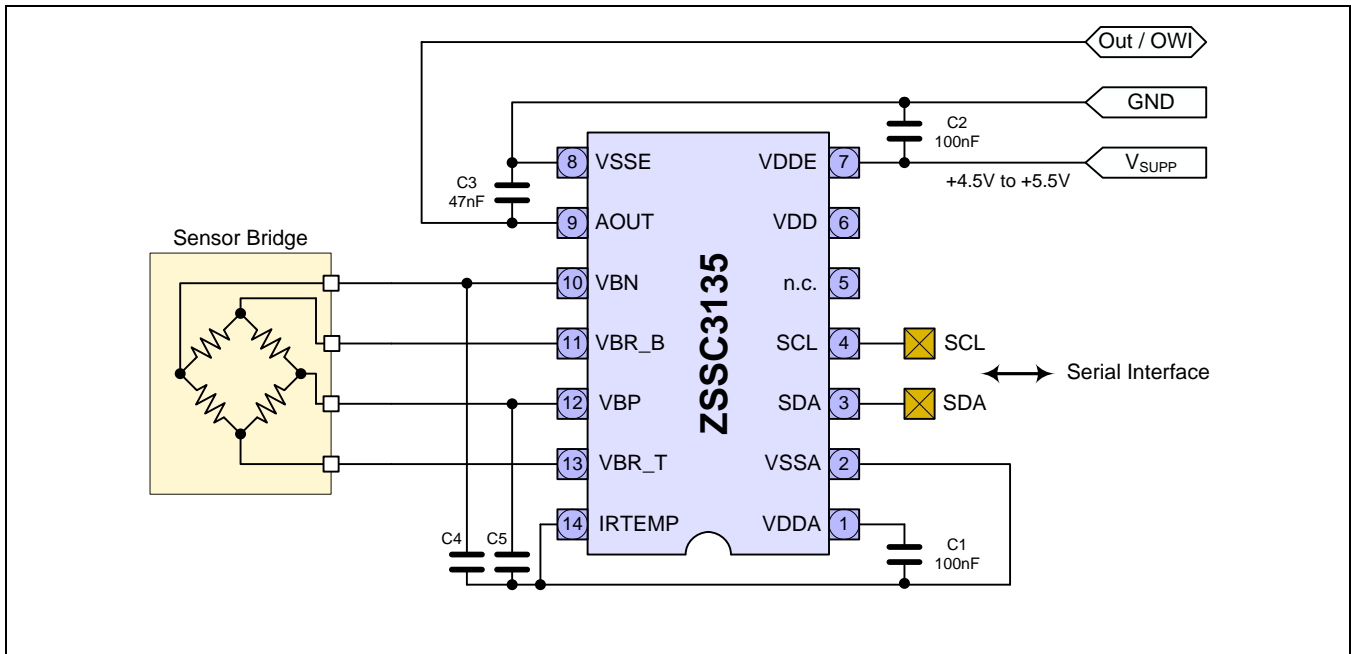

Figure 3.2 Application with External Diode Temperature Sensor

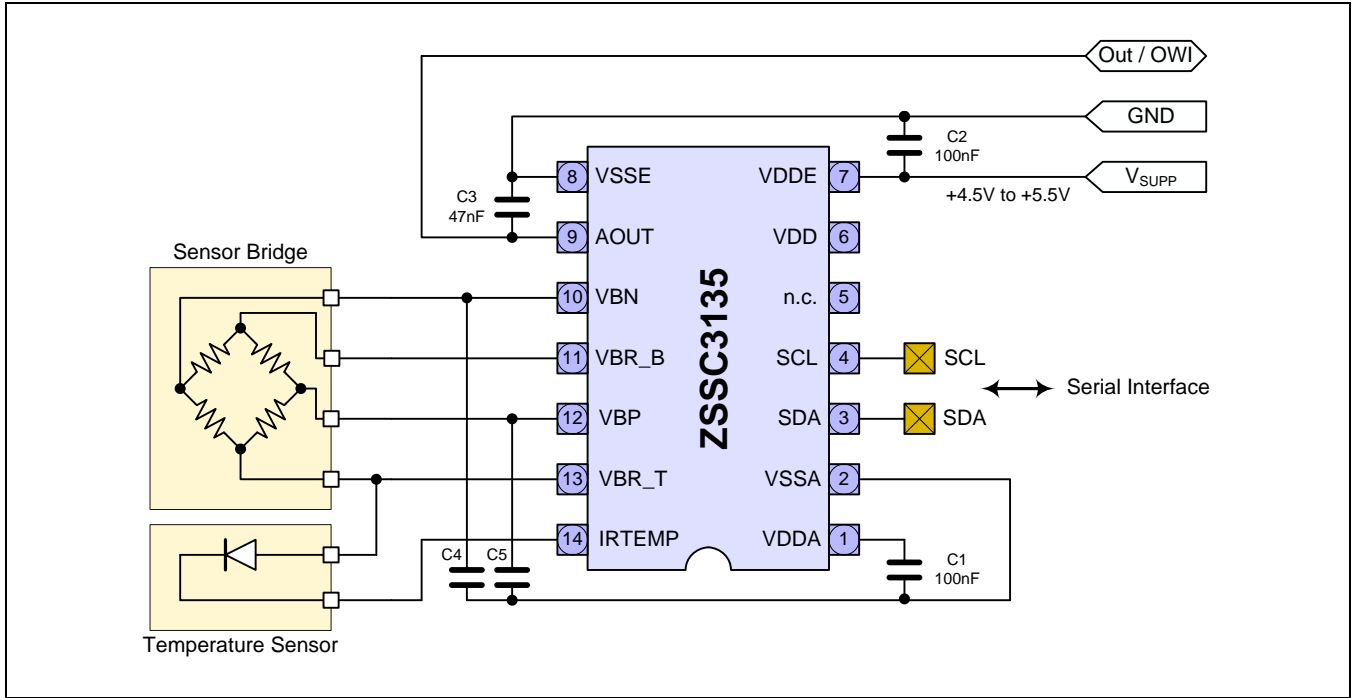
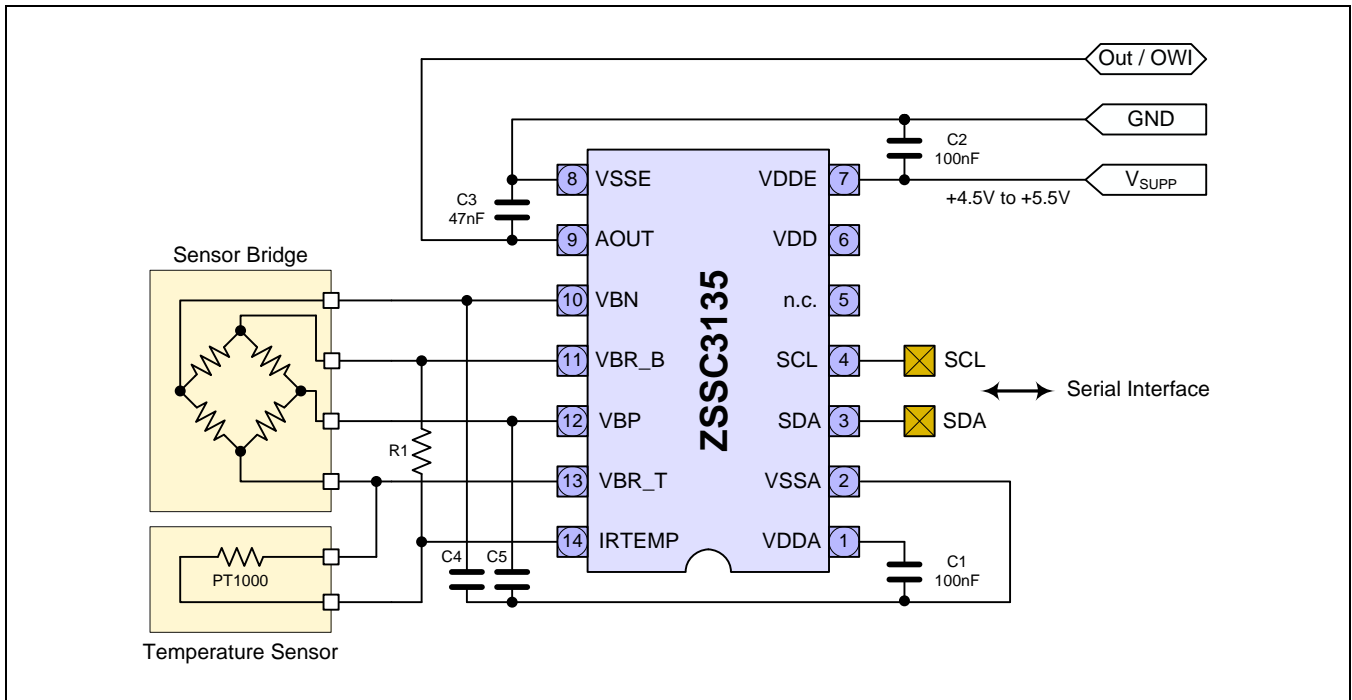

Figure 3.3 Application with External Thermistor



4 Pin Configuration and Package

Table 4.1 Pin Configuration and Definition

Pin No	Pin Name	Description	Remarks
1	VDDA	Positive Analog Supply Voltage	Internal analog supply
2	VSSA	Negative Analog Supply Voltage	Internal analog ground
3	SDA	I ² C™ Serial Data	Digital I/O; internal pull-up to VDDA
4	SCL	I ² C™ Clock	Digital input; internal pull-up to VDDA
5	N.C.	Not connected	
6	VDD	Positive Digital Supply Voltage	Internal digital supply
7	VDDE	Positive External Supply Voltage	High voltage analog supply
8	VSSE	Negative External Supply Voltage	Ground
9	AOUT	Analog Output and ZACwire™ Serial Data	High voltage analog I/O
10	VCN	Negative Input from Sensor Bridge	Analog input
11	VBR_B	Negative Sensor Bridge Supply Voltage	Analog I/O Depending on application circuit, short to VSSA
12	VBP	Positive Input from Sensor Bridge	Analog input
13	VBR_T	Positive Sensor Bridge Supply Voltage	Analog I/O Depending on application circuit, short to VDDA
14	IRTEMP	External Temperature Sensor	Analog I/O

The standard package of the ZSSC3135 is an RoHS-compliant SSOP14 “green” package (5.3mm body width) with a lead pitch of 0.65 mm.

Figure 4.1 ZSSC3135 SSOP14 Pin Diagram

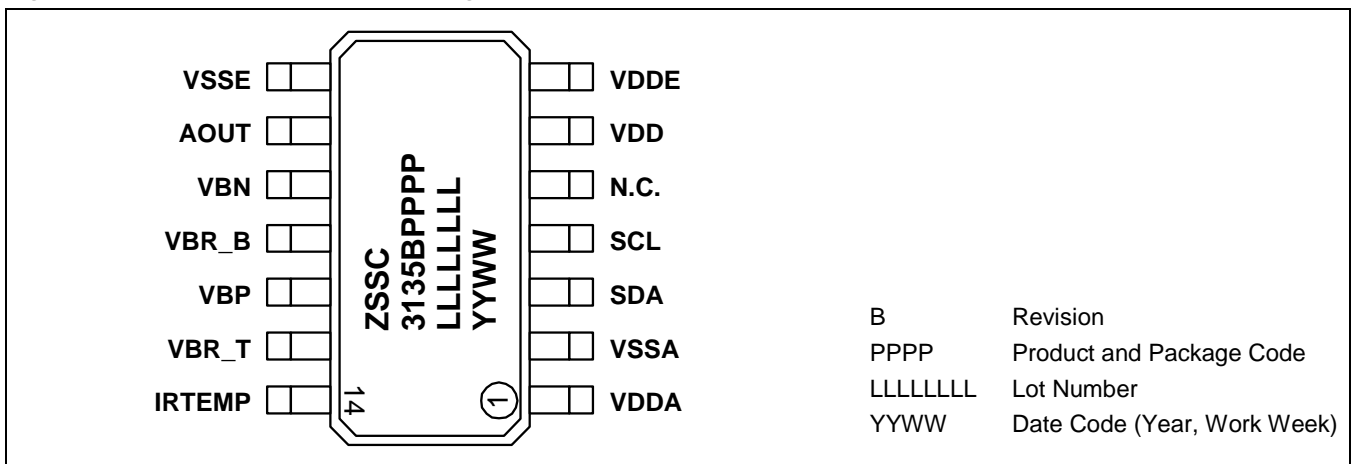

5 ESD Protection

All pins have an ESD protection of >2000V according to the Human Body Model (HBM). The pins VDDE, VSSE and AOUT have an additional ESD protection of >4000V (HBM).

ESD protection is tested with devices in SSOP14 packages during product qualification. The ESD test follows the Human Body Model with 1.5kOhm/100pF based on MIL 883, Method 3015.7.

6 Quality and Reliability

The ZSSC3135 is qualified according to the AEC-Q100 standard, operating temperature grade 0.

A fit rate <5fit (T=55°C, S=60%) is guaranteed. A typical fit rate of the semiconductor technology used is 2.5fit.

7 Customization

For high-volume applications that require an upgraded or downgraded functionality compared to the ZSSC3135, IDT can customize the circuit design by adding or removing certain functional blocks.

Please contact IDT for further information.

8 Ordering Information

Product Sales Code	Description	Package
ZSSC3135BA2T	ZSSC3135 SSOP14 – temperature range -40 to +125°C	Tube
ZSSC3135BA2R	ZSSC3135 SSOP14 – temperature range -40 to +125°C	Reel
ZSSC3135BA1B	ZSSC3135 die – temperature range -40 to +125°C	Tested dice on unsawn wafer
ZSSC3135BA1C	ZSSC3135 die – temperature range -40 to +125°C	Tested dice on frame
ZSSC3135BE2T	ZSSC3135 SSOP14 – temperature range -40 to +150°C	Tube
ZSSC3135BE2R	ZSSC3135 SSOP14 – temperature range -40 to +150°C	Reel
ZSSC3135BE1B	ZSSC3135 die – temperature range -40 to +150°C	Tested dice on unsawn wafer
ZSSC3135BE1C	ZSSC3135 die – temperature range -40 to +150°C	Tested dice on frame
ZSSC313xKITV1.1	ZSSC313x Evaluation Kit, revision 1.1, including Evaluation Board, ZSSC3135 IC samples, USB cable (software can be downloaded from the product page www.IDT.com/ZSSC3135)	Kit
ZSSC313x Mass Calibration System V1.1	Modular Mass Calibration System (MSC) for ZSSC313x including MCS boards, cable, connectors (software can be downloaded from the product page www.IDT.com/ZSSC3135)	Kit

9 Related Documents

Document
ZSSC3135 Feature Sheet
ZSSC313x Functional Description
ZSSC313x Evaluation Kit Description
ZSSC313x Technical Note—EMC Design Guidelines*
ZSSC313x Technical Note—High Voltage Protection*
ZSSC313x Technical Note Die & Package Dimensions**
IDT Wafer Dicing Guidelines
ZSSC313x Temperature Profile Calculation Spread Sheet
ZSSC313x Bandwidth Calculation Spread Sheet**

Visit the ZSSC3135 product page (www.IDT.com/ZSSC3135) or contact your nearest sales office for the latest version of these documents.

* Documents marked with an asterisk (*) require a login account for access on the web.

** Documents marked with a double asterisk (**) are available only on request.

10 Glossary

Term	Description
ADC	Analog-to-Digital Converter
AEC	Automotive Electronics Council
AFE	Analog Front-end
AOUT	Analog Output
BAMP	Buffer Amplifier
BR	Bridge Sensor Signal
CM	Command Mode
CMC	Calibration Microcontroller
CMOS	Complementary Metal Oxide Semiconductor
DAC	Digital-to-Analog Converter
DM	Diagnostic Mode
EEPROM	Electrically Erasable Programmable Read-Only Memory
ESD	Electrostatic Device

Term	Description
LDR	Lower Diagnostic Range
MUX	Multiplexer
NOM	Normal Operation Mode
OWI	One-Wire Communication
PGA	Programmable Gain Amplifier
POR	Power-on Reset
RAM	Random-Access Memory
RISC	Reduced Instruction Set Computer
ROM	Read-Only Memory
SCC	Sensor Connection Check
SSC	Sensor Signal Conditioner or Sensor Short Check depending on context.
T	Temperature Sensor Signal
TS	Temperature Sensor

11 Document Revision History

Revision	Date	Description
1.00	October 18, 2011	First released revision.
1.10	January 20, 2012	Full revision.
1.20	September 25, 2012	Minor edits. Update for IDT contact information.
1.21	February 15, 2013	Updates to specifications in section 1.3.7. Addition of RS factor (ADC Range Shift) to equation (2). Minor edits. Update for ZMD America contact information.
1.22	October 21, 2013	Update for available part codes. Update for contact information and imagery for cover and header. Update for related documents. Minor edits for clarity.
1.23	April 21, 2014	Update to description for kits: software is no longer included in kits. It is downloaded from the product page www.IDT.com/ZSSC3135 . Update for kit revision. Update for cover imagery, contact information, and related documents.
1.24	April 10, 2015	Update for contact information.
	January 27, 2016	Changed to IDT branding.

IMPORTANT NOTICE AND DISCLAIMER

RENESAS ELECTRONICS CORPORATION AND ITS SUBSIDIARIES (“RENESAS”) PROVIDES TECHNICAL SPECIFICATIONS AND RELIABILITY DATA (INCLUDING DATASHEETS), DESIGN RESOURCES (INCLUDING REFERENCE DESIGNS), APPLICATION OR OTHER DESIGN ADVICE, WEB TOOLS, SAFETY INFORMATION, AND OTHER RESOURCES “AS IS” AND WITH ALL FAULTS, AND DISCLAIMS ALL WARRANTIES, EXPRESS OR IMPLIED, INCLUDING, WITHOUT LIMITATION, ANY IMPLIED WARRANTIES OF MERCHANTABILITY, FITNESS FOR A PARTICULAR PURPOSE, OR NON-INFRINGEMENT OF THIRD-PARTY INTELLECTUAL PROPERTY RIGHTS.

These resources are intended for developers who are designing with Renesas products. You are solely responsible for (1) selecting the appropriate products for your application, (2) designing, validating, and testing your application, and (3) ensuring your application meets applicable standards, and any other safety, security, or other requirements. These resources are subject to change without notice. Renesas grants you permission to use these resources only to develop an application that uses Renesas products. Other reproduction or use of these resources is strictly prohibited. No license is granted to any other Renesas intellectual property or to any third-party intellectual property. Renesas disclaims responsibility for, and you will fully indemnify Renesas and its representatives against, any claims, damages, costs, losses, or liabilities arising from your use of these resources. Renesas' products are provided only subject to Renesas' Terms and Conditions of Sale or other applicable terms agreed to in writing. No use of any Renesas resources expands or otherwise alters any applicable warranties or warranty disclaimers for these products.

(Disclaimer Rev.1.01)

Corporate Headquarters

TOYOSU FORESIA, 3-2-24 Toyosu,
Koto-ku, Tokyo 135-0061, Japan
www.renesas.com

Trademarks

Renesas and the Renesas logo are trademarks of Renesas Electronics Corporation. All trademarks and registered trademarks are the property of their respective owners.

Contact Information

For further information on a product, technology, the most up-to-date version of a document, or your nearest sales office, please visit www.renesas.com/contact-us/.