

## Introduction

The ISL28474EVAL1Z evaluation board is a design platform containing all the circuitry needed to characterize critical performance parameters of the ISL28474 instrumentation and precision operational amplifiers, using a variety of user defined test circuits.

The ISL28474 is the combination of two micropower instrumentation amplifiers (Amp A) and two low power precision amplifiers (Amp B) in a single package. This device is optimized for 2.4V to 5V single supplies, and can be operated from one lithium cell or two Ni-Cd batteries.

## Ordering Information

- ISL28474EVAL1Z

## Reference Documents

- ISL28274, ISL28474 Data Sheet

## Evaluation Board Key Features

The ISL28474EVAL1Z is designed to be operated from a single supply (+2.4VDC to +5VDC), or from split supplies ( $\pm 1.2$ VDC to  $\pm 2.5$ V). Amp A is compensated for a gain of 100, and Amp B is compensated for a gain of 10. Each precision amplifier contains its own VREF input to establish an input common mode reference. An  $\overline{\text{ENABLE}}$  select switch is provided for each amplifier to be used to save power by powering the device down.

## Power Supplies (Refer to Figure 1)

External power connections are made through the VSP (+V), VSM (-V) and Ground connections on the evaluation board. For single supply operation, the VSM and Ground pins are tied together to the power supply negative terminal. For split supplies VSP and VSM connect to their respective power supply terminals. Resistors  $R_3$  and  $R_{34}$  are  $0\Omega$  but can be changed by the user to provide power supply filtering, or to reduce the voltage rate-of-rise to less than  $\pm 1$ V/ $\mu$ s. Anti-reverse diodes  $D_1$ ,  $D_2$  and  $D_3$  protect the circuit in the case of accidental polarity reversal.

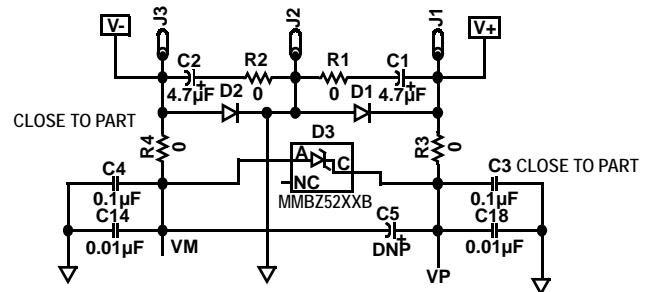

FIGURE 1. POWER SUPPLY CIRCUIT

## Amplifier Configuration (Figures 2 and 3)

The schematic of instrumentation amplifiers (Amp A) is shown with components supplied in Figure 2, and the schematic of precision amplifiers (Amp B), is shown with components supplied in Figure 3.

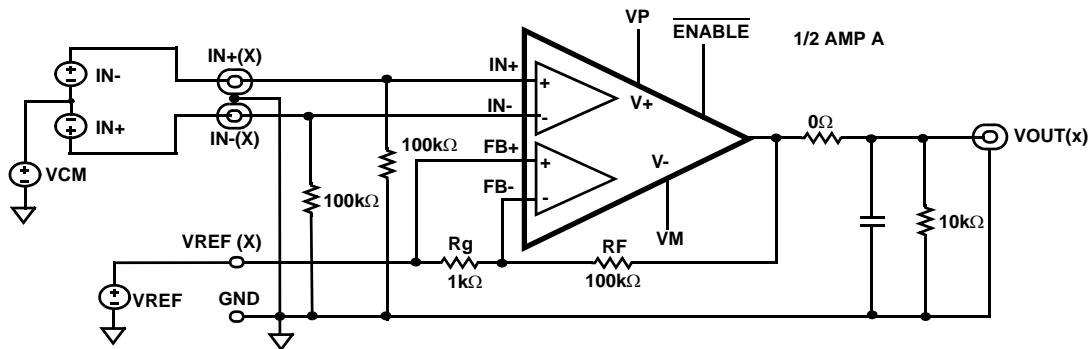

FIGURE 2. BASIC INSTRUMENTATION AMPLIFIER CIRCUIT

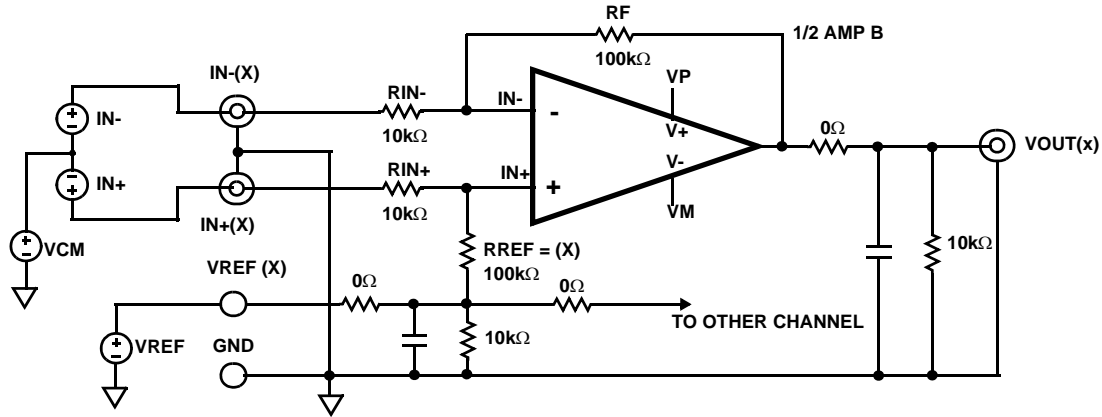

FIGURE 3. BASIC PRECISION AMPLIFIER CIRCUIT

**User-selectable Options (Figures 4 and 5)**

Component pads are included to enable a variety of user-selectable circuits to be added to the amplifier differential inputs, the VREF input, outputs and the amplifier feedback loop. The outputs (Figure 4) have additional resistor and capacitor placements for loading.

A voltage divider and filter option (Figure 5) can be added to establish a power supply tracking common mode reference at the VREF input. The differential inputs have additional resistor placements for adding input attenuation, or to establish input DC offsets through the VREF pin (AMP B). For Amp A (Figure 5, Top), a coaxial connection to the amplifier FB+ pin can be made at the FB+ BNC connector. For Amp B (Figure 5, Bottom), the additional unpopulated components allow the user to configure the board for a variety of other applications such as cascaded gain stages, active feedback loops, etc.

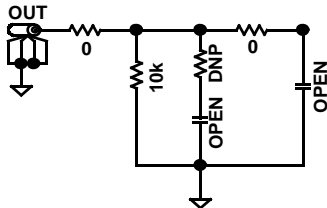

FIGURE 4. OUTPUT STAGE

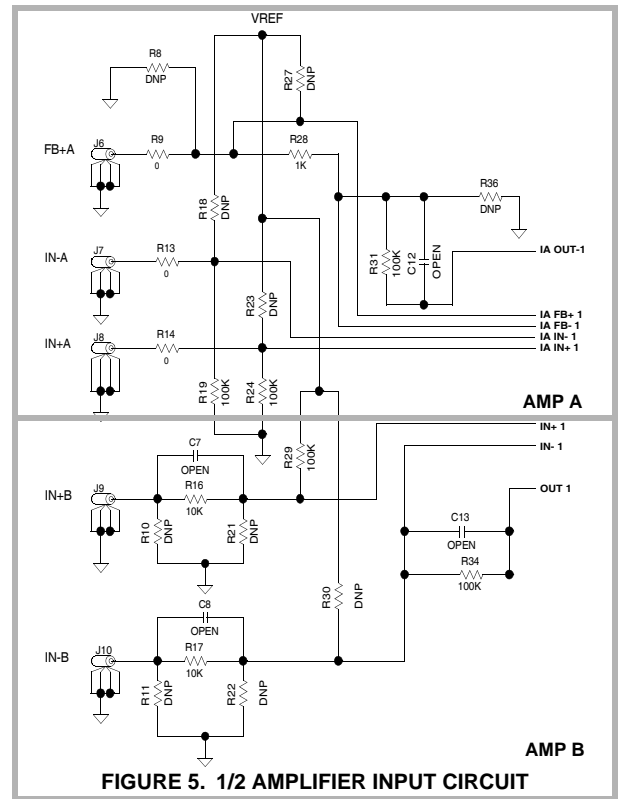

FIGURE 5. 1/2 AMPLIFIER INPUT CIRCUIT

## Application Note 1353

### ISL28474EVAL1Z Components Parts List

DEVICE NUMBER	DESCRIPTION	COMMENTS
C <sub>1</sub> , C <sub>2</sub> , C <sub>6</sub>	CAP, SMD, 1206, 4.7μF, 25V, 10%, X7R, ROHS	Power Supply Decoupling
C <sub>3</sub> , C <sub>4</sub> , C <sub>23</sub>	CAP, SMD, 0805, 0.1μF, 25V, 10%, X7R, ROHS	Power Supply Decoupling
C <sub>14</sub> , C <sub>18</sub>	CAP, SMD, 0805, 0.01μF, 25V, 10%, X7R, ROHS	Power Supply Decoupling
C <sub>7</sub> -C <sub>13</sub> , C <sub>15</sub> -C <sub>17</sub> , C <sub>19</sub> -C <sub>22</sub>	CAP, SMD, 0805, DNP-PLACE HOLDER, ROHS	Optional Caps Not Populated
C <sub>5</sub>	CAP-TANTALUM, SMD, D, 10μF, 35V, 10%, LOW ESR, ROHS	Optional Filter Not Populated
D <sub>1</sub> , D <sub>2</sub> , D <sub>3</sub>	DIODE-RECTIFIER, SMD, ROHS	Reverse Power Protection
U <sub>1</sub>	ISL28474FAZ INSTRUMENTATION AMP/PRECISION AMP COMBINATION ,24P, QSOP, ROHS	
R <sub>8</sub> , R <sub>10</sub> , R <sub>11</sub> , R <sub>18</sub> , R <sub>20</sub> -R <sub>23</sub> , R <sub>27</sub> , R <sub>30</sub> , R <sub>32</sub> , R <sub>35</sub> -R <sub>37</sub> , R <sub>39</sub> -R <sub>42</sub> , R <sub>47</sub> , R <sub>48</sub> , R <sub>51</sub> , R <sub>54</sub> -R <sub>56</sub> , R <sub>58</sub> , R <sub>66</sub> , R <sub>68</sub> , R <sub>69</sub>	RES, SMD, 0805, DNP-PLACE HOLDER, ROHS	User Selectable Resistors Not Populated
R <sub>1</sub> -R <sub>5</sub> , R <sub>7</sub> , R <sub>9</sub> , R <sub>13</sub> , R <sub>14</sub> , R <sub>25</sub> , R <sub>26</sub> , R <sub>53</sub> , R <sub>57</sub> , R <sub>64</sub> , R <sub>65</sub> , R <sub>67</sub> , R <sub>70</sub>	RES, SMD, 0805, 0W, 1/8W, TF, ROHS	0W User Selectable Resistors
R <sub>28</sub> , R <sub>49</sub>	RES, SMD, 0805, 1k, 1/8W, 1%, TF, ROHS	User Selectable Resistors
R <sub>6</sub> , R <sub>12</sub> , R <sub>15</sub> -R <sub>17</sub> , R <sub>33</sub> , R <sub>38</sub> , R <sub>44</sub> , R <sub>45</sub> , R <sub>60</sub> , R <sub>63</sub>	RES, SMD, 0805, 10k, 1/8W, 1%, TF, ROHS	User Selectable Resistors
R <sub>19</sub> , R <sub>24</sub> , R <sub>29</sub> , R <sub>31</sub> , R <sub>34</sub> , R <sub>43</sub> , R <sub>46</sub> , R <sub>50</sub> , R <sub>52</sub> , R <sub>59</sub>	RES, SMD, 0805, 100k, 1/10W, 1%, TF, ROHS	User Selectable Resistors
S <sub>1</sub> -S <sub>4</sub>	SWITCH-SEALED MINI TOGGLE, TH, 3P, SP, ON/NONE/ON, GOLD	Enable/Disable Select Switches

ISL28474EVAL1Z Top View

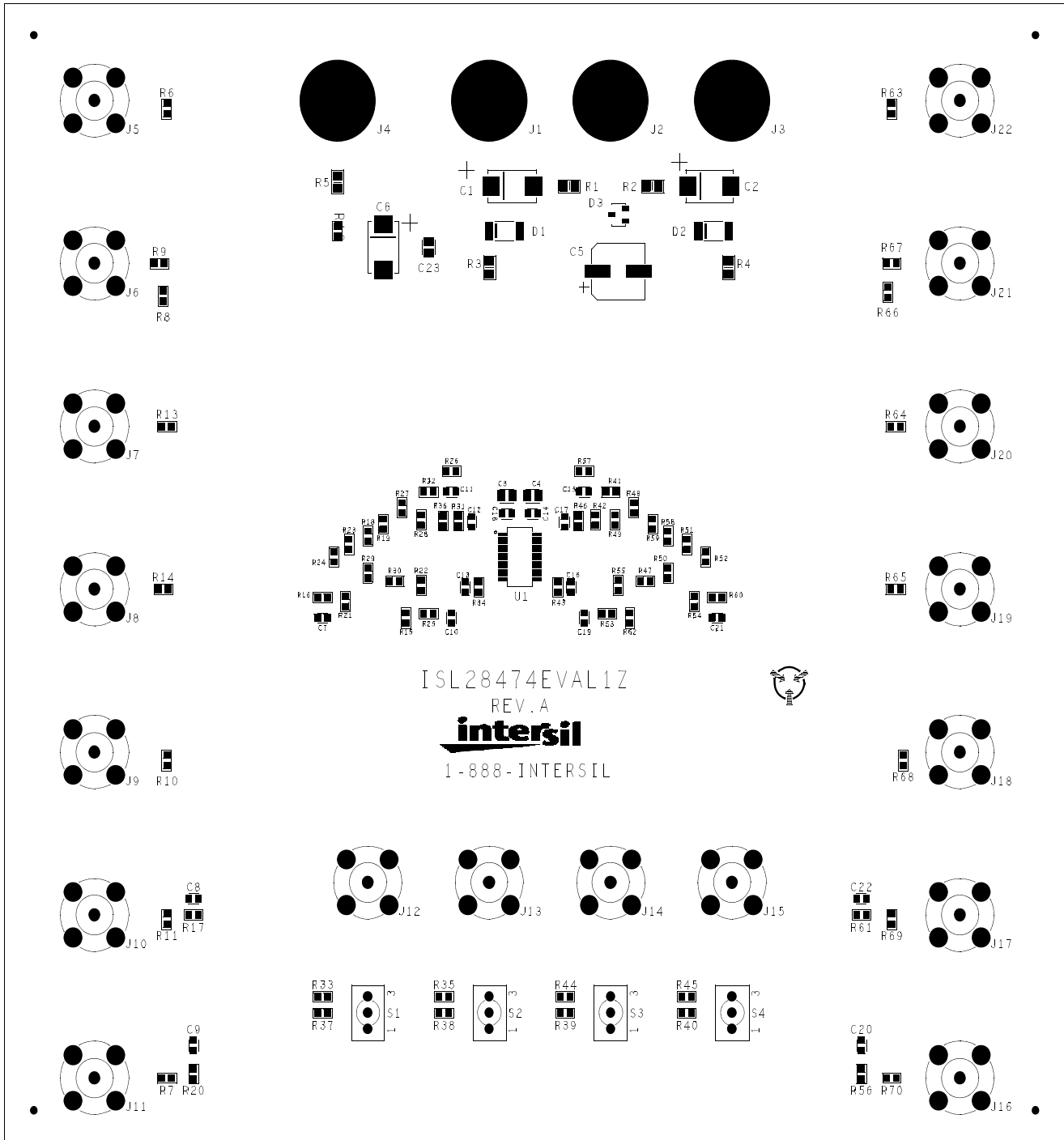

Intersil Corporation reserves the right to make changes in circuit design, software and/or specifications at any time without notice. Accordingly, the reader is cautioned to verify that the Application Note or Technical Brief is current before proceeding.

For information regarding Intersil Corporation and its products, see [www.intersil.com](http://www.intersil.com)

# ISL28474EVAL1Z Schematic Diagram

