

Introduction

The ISL59442EVAL1 evaluation board contains all the circuitry needed to characterize critical performance parameters of the ISL59442 single 4:1 MUX-amplifier, over a variety of applications.

The ISL59442 is a single-output 4:1 MUX-amp. The output amplifier unity-gain bandwidth is 1GHz. The device contains logic inputs for channel selection (S0, S1), and a three-state output control (HIZ) for individual selection of MUX amps that share a common video output line.

The evaluation board circuit and layout is optimized for either 50Ω or 75Ω terminations, and implements a basic single 4:1 video MUX-amp. The board is supplied with 75Ω input signal terminations and a 75Ω back-termination resistor on each of the 3 outputs, making it suitable for driving video cable. The user has the option of replacing the 75Ω resistors with 50Ω resistors for other applications. The control lines contain 50Ω resistors to match the 50Ω output impedance of high speed pulse generators. Control line termination resistors are recommended for rise and fall times under 10ns to minimize unwanted transients. If DC is used for the control logic, the resistors may be removed; or the applied DC voltage can be reduced to 2.5V to reduce the dissipation in the termination resistor.

The layout contains component options to include an output series resistor (R_S) followed by a parallel resistor (R_L) capacitor (C_L) network to ground. This option allows the user to select several different output configurations. Examples are shown in Figures 2A, 2B, and 2C. The evaluation board is supplied with the 75Ω back termination resistors shown in Figure 2C.

Amplifier Performance and Output Configurations

The ISL59442 output amplifier is sensitive to capacitance at the output. For best AC performance, a series output resistor is required to reduce excessive gain peaking, particularly when long PB board traces are used. The output amplifier is ideally suited for driving high impedance high speed selectable-gain buffers when gain compensation is needed. GBW decreases slightly at the lower output load impedances typical of back-terminated cable driving applications. Reference data sheets for additional performance data.

High Frequency Layout Considerations

At frequencies of 500MHz and higher, circuit board layout may limit performance. The following layout guidelines are implemented on the evaluation board:

- Signal I/O lines are the same lengths and widths to match propagation delay and trace parasitics.
- No series connected vias are used in signal I/O lines, as they can add unwanted inductance.
- Signal trace lengths are minimized to reduce transmission line effects and the need for strip-line tuning of the signal traces.
- High frequency decoupling caps are placed as close to the device power supply pin as possible - without series vias between the capacitor and the device pin.

Power Sequencing

Proper power supply sequencing is -V first, then +V. In addition, the +V and -V supply pin voltage rate-of-rise must be limited to $\pm 1V/\mu s$ or less. The evaluation board contains parallel-connected low V_{ON} Schottky diodes on each supply terminal to minimize the risk of latch up due to incorrect sequencing. In addition, extra 10μF decoupling capacitors are added to each supply to aid in reducing the applied voltage rate-of-rise.

Reference Documents

- ISL59442 Data Sheet, FN7452

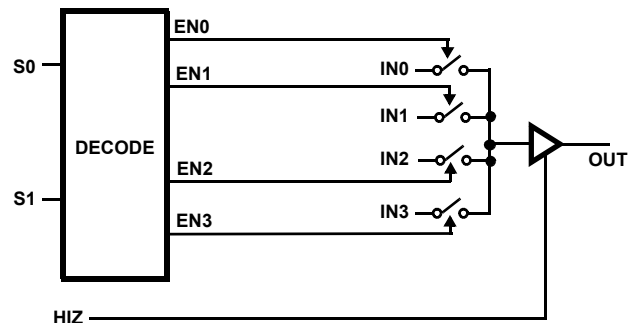
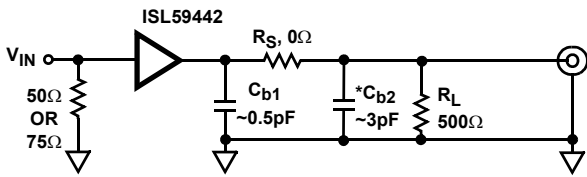

FIGURE 1. ISL59442 FUNCTIONAL BLOCK DIAGRAM

Application Note 1185

TABLE 1. LOGIC TABLE

S0	S1	HIZ	OUT
0	0	0	IN0
1	0	0	IN1
0	1	0	IN2
1	1	0	IN3
-	-	1	High Z



* C_{b1} , C_{b2} are approximate PCB trace capacitances.

FIGURE 2A. TEST CIRCUIT WITH OPTIMAL OUTPUT LOAD

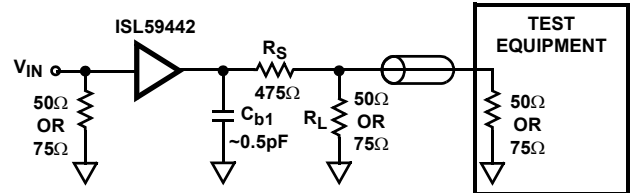

* C_{b1} is approximate PCB trace capacitance.

FIGURE 2B. TEST CIRCUIT FOR 50Ω OR 75Ω TERMINATIONS

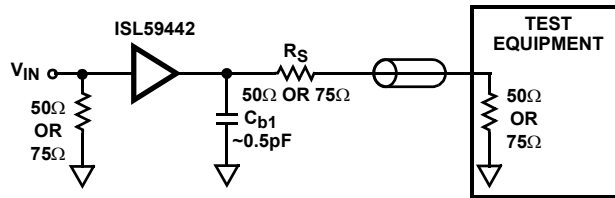

* C_{b1} is approximate PCB trace capacitance.

FIGURE 2C. BACK-TERMINATED TEST CIRCUIT FOR CABLE APPLICATION

ISL59442EVAL1 Top View

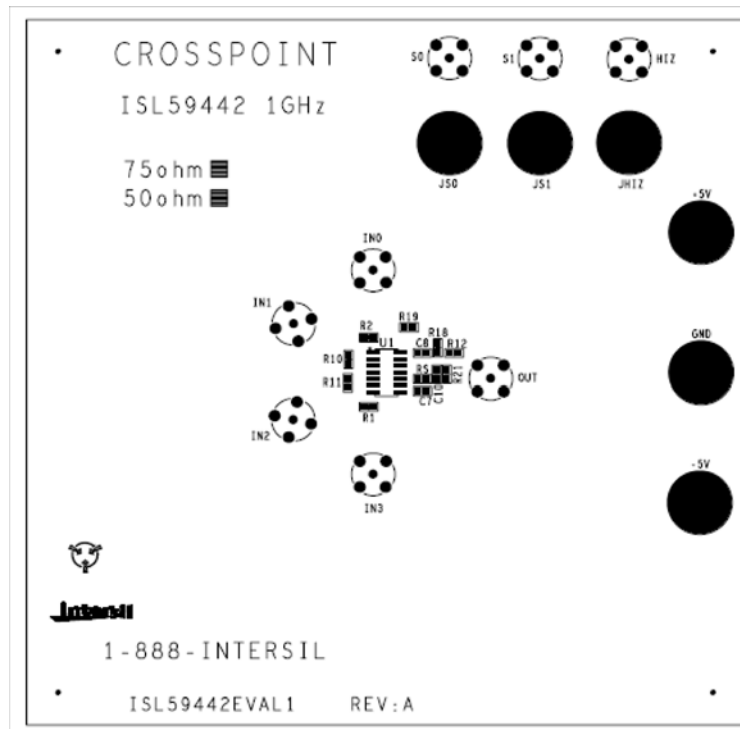

ISL59442EVAL1 Schematic Diagram

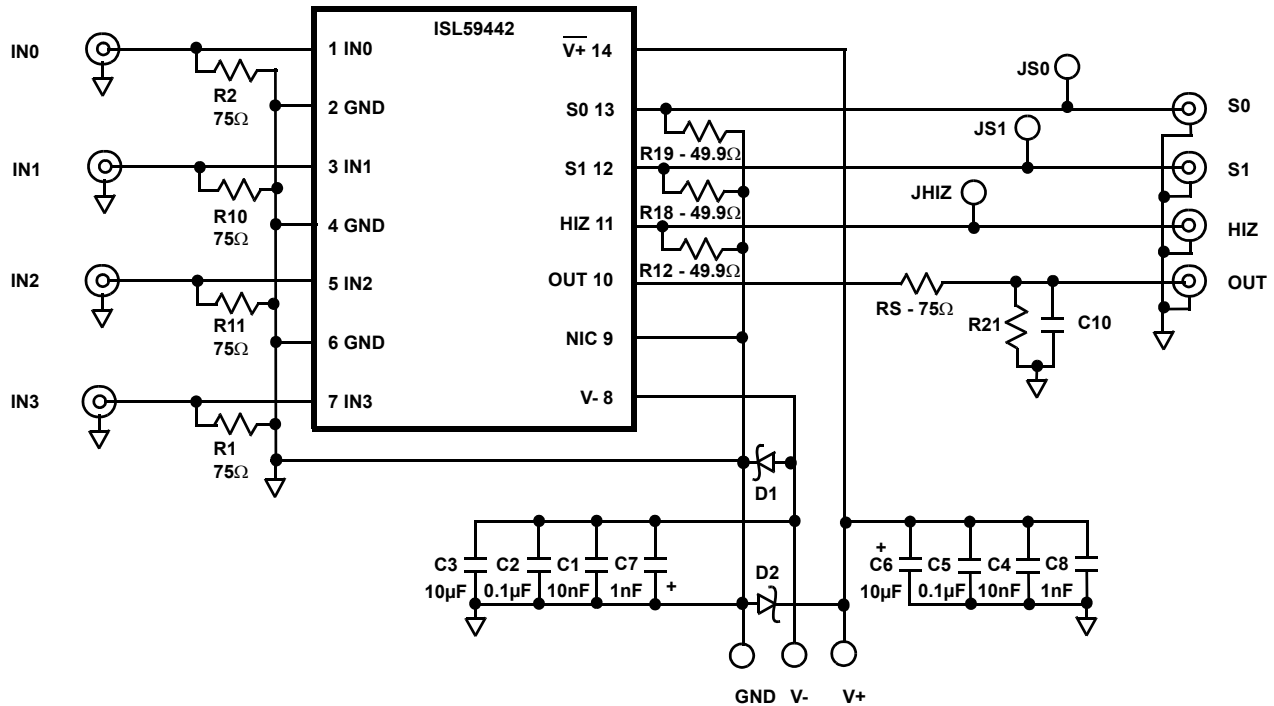

ISL59442EVAL1 Components Parts List

DEVICE #	DESCRIPTION	COMMENTS
C7, C8	CAP, SMD, 0603, 1000pF, 25V, 10%, X7R	Power Supply Decoupling
C1, C4	CAP, SMD, 0603, 0.01μF, 25V, 10%, X7R	Power Supply Decoupling
C2, C5	CAP, SMD, 0603, 0.1μF, 25V, 10%, X7R	Power Supply Decoupling
C3, C6	CAP, SMD, 0805, 10μF, 6.3V, 10%, X5R	Power Supply Decoupling
D1, D2	Diode-Schottky, 2 Pin, 45V, 7.5A	MBR0550T (Motorola) Reverse Polarity Protection
R1, R2, R10, R11, RS	Resistor, SMD, 0603, 75Ω, 1/10W, 1%	Signal Input/output Termination
R12, R18, R19	Resistor, SMD, 0603, 49.9Ω, 1/16W, 1%	Logic Input Termination
C10	Resistor, SMD, 0603	Optional, not populated
R21	Resistor, SMD, 0603	Optional, not populated
U1	ISL59442 - 1GHz Multiplexing Amplifier, 14P, QSOP	Device Under Test

Intersil Corporation reserves the right to make changes in circuit design, software and/or specifications at any time without notice. Accordingly, the reader is cautioned to verify that the Application Note or Technical Brief is current before proceeding.

For information regarding Intersil Corporation and its products, see www.intersil.com