

This application note describes the ISL6237 evaluation board intended for applications in notebook computers and other battery-powered devices.

Description

As notebook computer and battery-powered equipment complexity increases, higher levels of power management integration are required to meet market demands. To respond to the dynamic needs of its customers, Intersil introduces the quad outputs, multi-function power supply controller ISL6237. Its two fully programmable Switch-Mode Power Supplies (SPMS), one programmable and one fixed LDO outputs provide a robust power management solution for an extremely wide range of applications. In addition, it includes an optional 14V charge pump. For more information on the detailed workings of the ISL6237, please consult the ISL6237 Data Sheet on the Intersil Company website (<http://www.intersil.com>)

What's Inside

The Evaluation Board Kit contains the following materials:

- ISL6237 EVAL1 REV B Board
- ISL6237 Data Sheet
- ISL6237 Application Note (this document)

What's Needed

The following materials will be needed to perform testing:

- +25V, 20A Power Supply
- +5.0V, 750mA Power Supply
- Electronic Load up to 15A
- Precision digital multimeter
- 4-Channel oscilloscope

Note: amperage rating of power supplies are determined by maximum expected loading plus a percentage margin of error.

Quick Setup Guide

1. Set the +25V power supply to +7V and place in the "STANDBY" or "OFF" position. Connect the positive terminal (+) of the supply to the +VIN terminal P1 and the negative terminal (-) of the supply to GND P2.
2. Connect the positive terminal (+) of the electronic load to the VOUT1 terminal P5. Connect the negative terminal (-) of the electronic load to the GND terminal P6. Make sure the electronic load is set to the 0A condition.
3. Check to ensure all switches are in their default positions prior to application of power (refer to "Detailed Description of Switch Settings." on page 2).
4. Set all power supplies to the "ON" position. Check both 5V and 25V power supply outputs with a DMM to ensure correct voltage levels. Adjust if necessary.
5. Measure the default output voltages using DMM across the test points.
 - VOUT1: P7(+) to P8(-), it should read 5.0V
 - VOUT2: P5(+) to P6(-), It should read 3.3V
 - LDO: P3(+) to P4(-), It should read 3.3V
 - VREF3: P14(+) to P8(-), It should read 3.3V
 - CHARGE PUMP: P28(+) to P8(-), it should read 14.0V.

At this point, the board has been properly powered up. Normal testing can begin.

Summary

The ISL6237EVAL1 is an adaptable evaluation tool which showcases the performance of the ISL6237 chipset designed to meet the power management requirements of personal notebook computers or portable devices.

The following pages provide jumper settings, pinout, schematic of the board, bill of materials and layout drawings to support implementation of this solution.

The Intersil's total power management portfolio continues to expand with new selections to better fit our customer's needs. Refer to our web site for updated information: <http://www.intersil.com>

For technical assistance or other assistance please call 1-888-INTERSIL (468-3774).

Detailed Description of Switch Settings.

SWITCH	NAME	FUNCTION	POSITION	CONNECTION	RESULT
SW1	EN2	VOUT2 OUTPUT CONTROL	1	EN2 to GND.	VOUT2 output shut-down.
			2	EN2 to VCC.	VOUT2 output active.
			3	EN2 to REF.	VOUT2 sequence to VOUT1 output.
SW2	BYP	OPERATING MODE	1	BYP to GND	Sets BYP to 0V, no LDO switchover
			2	BYP to Vout1	Sets BYP to Vout1
			3	BYP to Vout2	Sets BYP to Vout2
SW3	EN_LDO	LDO CONTROL	1	LDO to GND	LDO output shut-down
			2	LDO to VCC	LDO output active
			3	N/C	No connect
SW4	EN1		1	EN1 to GND.	VOUT1 output shut-down.
			2	EN1 to VCC.	VOUT1 output active.
			3	EN1 to REF.	VOUT1 sequence to VOUT2 output.
SW5	SKIP#		1	SKIP# to GND	Normal Operation Mode, allow automatic PWM/PFM switchover for pulse -skipping at light load
			2	SKIP# to VCC	Low Noise, Fixed-frequency PWM Mode
			3	SKIP# to REF	Ultrasonic pulse-skipping mode(20KHz Min)

Evaluating Variable Output Voltage

The ISL6237EVAL1 kit outputs are preset to 5V/7A, 3.3V/11A and 5V/200mA on LDO.

The VOUT1 can also be adjusted between 0.7V to 5.5V by changing the value of R13 and R14 given by Equation :

$$R14 = \frac{R13}{(V_{OUT}/V_{FB}) - 1} \quad (EQ. 1)$$

where $V_{FB} = 0.7V$

The VOUT2 can track REFIN2 at 1:1 ratio with input voltage range from 0.7V to 2.5V. Likewise, the LDO output can also track LDOREFIN at 1:2 with voltage range from 0.35V to 2.25V.

Pinouts

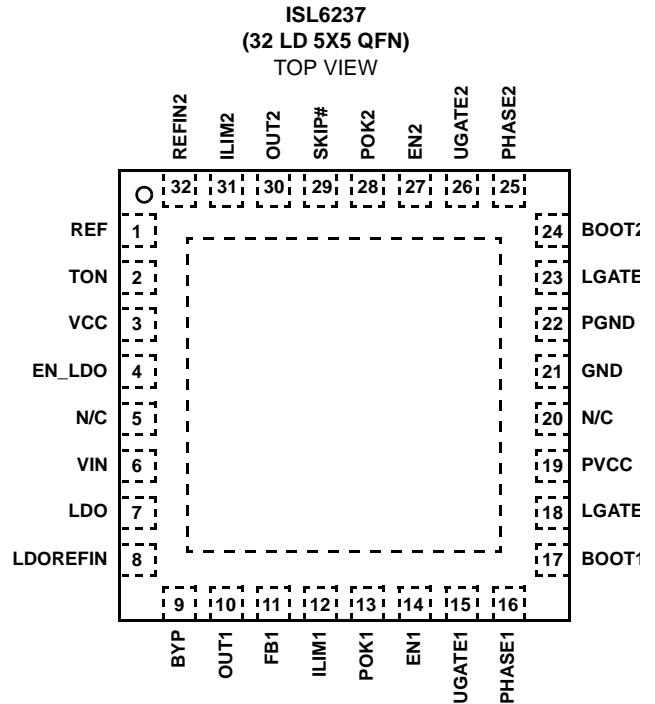

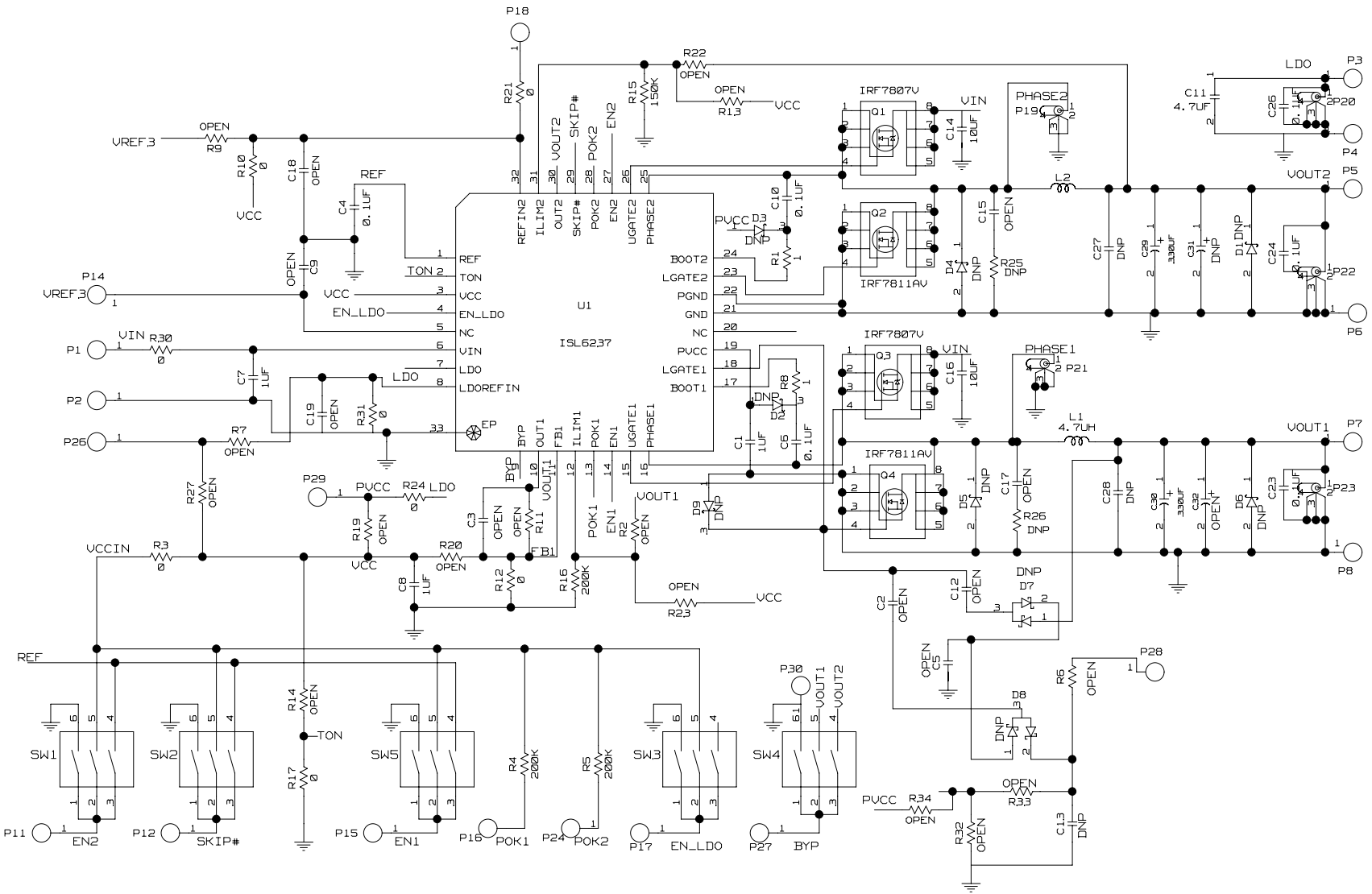

FIGURE 1. ISL6237EVAL1 REV B KIT SCHEMATIC

Components List

REF DES	PART NUMBER	QTY	MANUFACTURER	DESCRIPTION
C1, C7, C8	08053D105KAT2A	3	AVX	1µF, 25V, X7R, 0805
C11	H1065-00475-10V10	1	GENERIC	4.7µF, 10V X5R 1206
C14, C16	TMK432BJ106KM	2	TAIYO-YUDEN	10µF, 25V X5R 1210
C4, C6, C10, C23, C24, C26	H1046-00104-50V10	6	GENERIC	0.1µF, 50V, X7R, 0805
C27, C28	OPEN	0		Cap, SMD, 1206, Do Not Populate(DNP)
C29, C30	6TPD330M	2	POSCAP SANYO	330µF, 6.3V, POS CAP 9mΩ, D size
C2, C3, C5, C9, C12, C13, C15, C17, C18, C19	OPEN	0		Cap, SMD, 0805, Do Not Populate(DNP)
C31, C32	OPEN	0	POSCAP	Cap, SMD, Size D, DNP
D1, D4, D5, D6	OPEN	0	DIODES-INC	DNP
D2, D3	OPEN	0	ON-SEMI	DNP
D7, D8	OPEN	0	DIODES	DNP, 0.2A, 30V, Schottky SOT23
D9	Open	0	ON-SEMI	2A, 30V, Schottky SOT23
L1, L2	SD1003	2	FALCO	4.7µH, 20% 8.3A, 12.5mmx12.5mm Shielded
P1, P2, P5 to P8	1514-2	6	KEYSTONE	Test Point Turret 0.150 Pad 0.100 Thole
P19 to P23	131-4353-00	5	TEKTRONIX	Scope Probe Test Point PCB Mount
P3, P11, P12, P14 to P18, P24, P26, P27, P28, P29	5000	13	KEYSTONE	Miniature Red Test Point 0.100 Pad 0.040 Thole
P4, P30	5001	2	KEYSTONE	Miniature Black Test Point 0.100 Pad 0.040 Thole
Q1	IRF7821	1	IR	30V 13.6A HEXFET Power MOSFET
Q2	IRF7832	1	IR	30V 20A HEXFET Power MOSFET
Q3	IRF7807V	1	IR	30V 8.3A N-Channel Power MOSFET
Q4	IRF7811AV	1	IR	30V 10.8A N-Channel Power MOSFET
R1, R8	H2512-00010-1/8W	2	GENERIC	1Ω, 1%, 0805
R15	H2512-01503-1/10W1	1	GENERIC	150kΩ, 1%, 0805
R2, R6, R7, R9, R11, R13, R14, R19, R20, R22, R23, R27, R32, R33, R34	OPEN	0		Res, SMD, 0805, DNP
R25, R26	OPEN	0		CAP, SMD, 1206, DNP
R3, R10, R12, R17, R21, R24, R30, R31	H2512-00R00-1/10W	8	GENERIC	0Ω, 1%, 0805
R4, R5, R16,	H2512-02003-1/10W1	3	GENERIC	200kΩ, 1%, 0805
SW1 to SW5	78B03S	5	GRAYHILL	Dip Switch SPST (Raised Slide)
U1	ISL6237IRZA	1	INTERSIL	High-Efficiency, Quad Output Controller

Layout

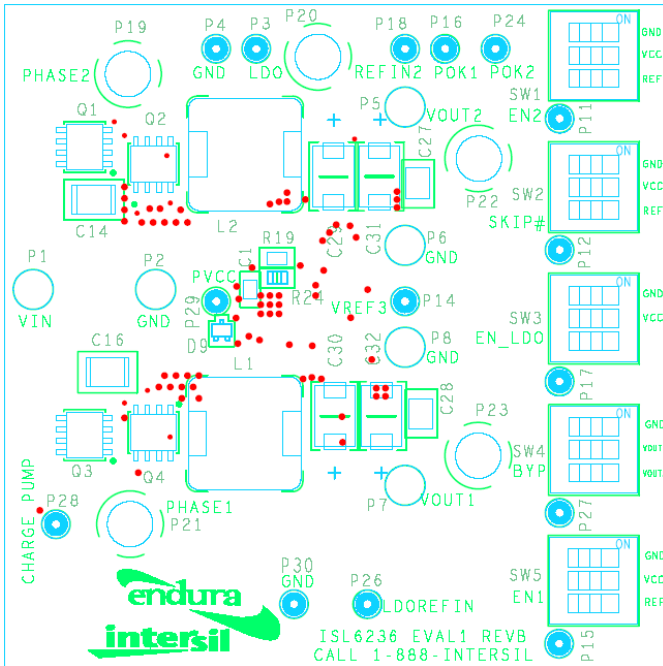

FIGURE 2. TOP COMPONENTS

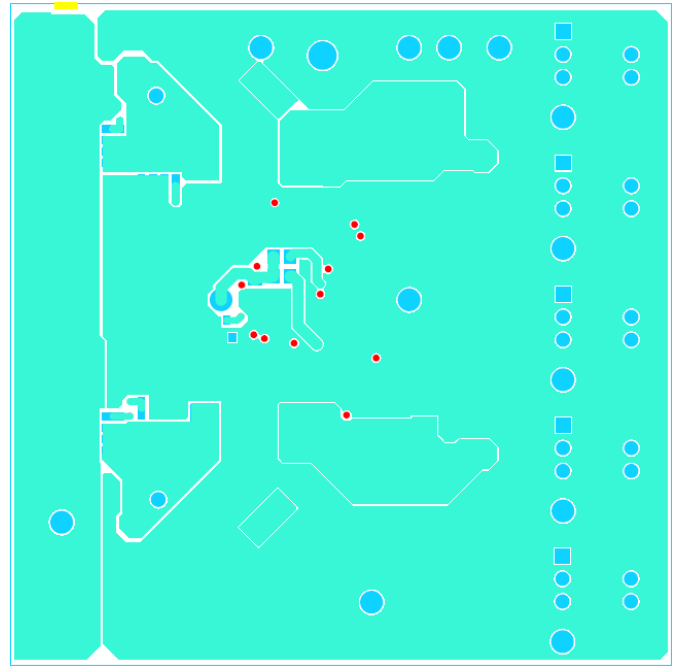

FIGURE 3. TOP ETCH

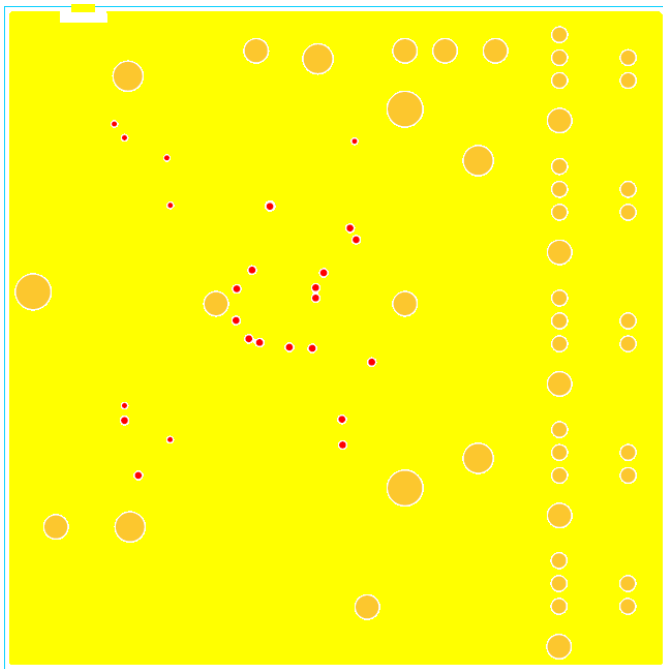

FIGURE 4. 2nd LAYER

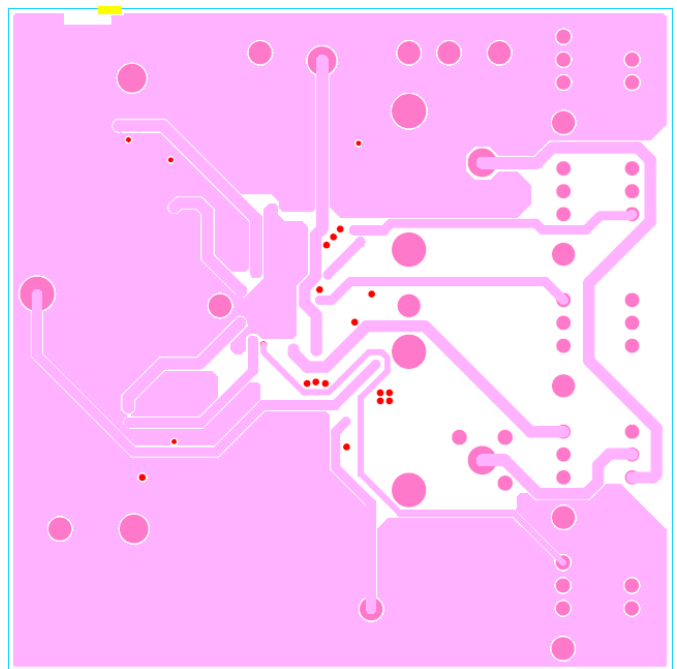

FIGURE 5. 3rd LAYER

Layout (Continued)

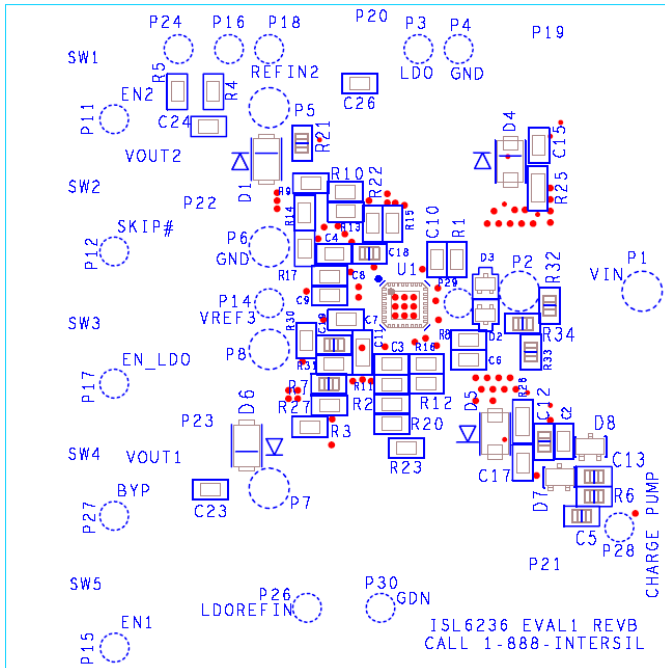

FIGURE 6. BOTTOM COMPONENTS (MIRRORED)

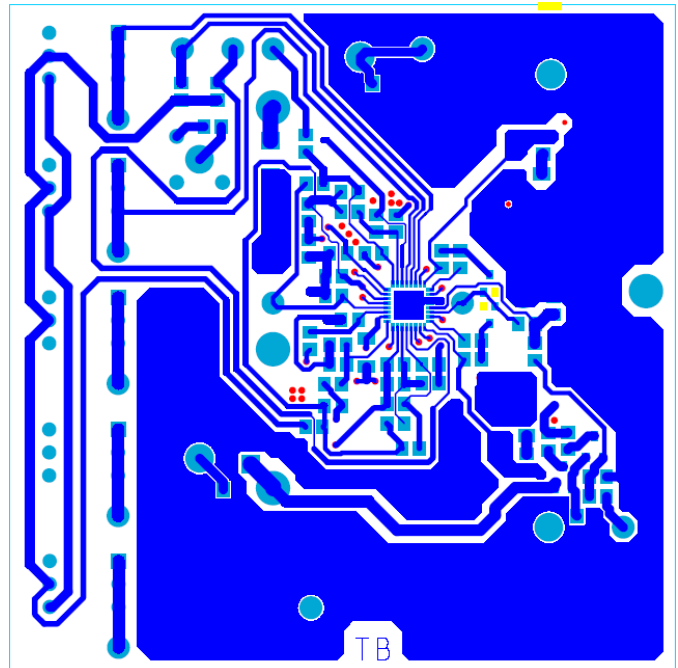

FIGURE 7. BOTTOM ETCH (MIRRORED)

Intersil Corporation reserves the right to make changes in circuit design, software and/or specifications at any time without notice. Accordingly, the reader is cautioned to verify that the Application Note or Technical Brief is current before proceeding.

For information regarding Intersil Corporation and its products, see www.intersil.com