

Description

The ISL6299AEVAL1 is an evaluation tool for the ISL6299A single-cell Li-ion battery charger. The evaluation tool provides a complete evaluation platform addressing all datasheet specifications and functionality. The jumpers on the board facilitate the programming of the charge current, different charging conditions, and can be used to make other necessary connections, such as current measurement.

The ISL6299A is a dual input, fully integrated single-cell Li-ion battery charger. The ISL6299A charger accepts two input sources: one from a USB port and the other from a desktop cradle. The cradle input accepts input voltages ranging from 4.5V up to 28V. Due to the high voltage capability, the components associated with the cradle input circuit on the evaluation board are good for a 28V supply. The charger's USB input and the associated components on the evaluation board are good for a maximum 6V input.

The components assembled in the center square constitute a complete charger, indicating the space saving advantage of the typical ISL6299A installation in space-limited applications.

Ordering Information

PART #	DESCRIPTION
ISL6299AEVAL1	Evaluation Board for ISL6299A

Pinout

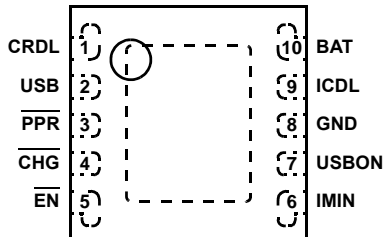

Features

- A Complete Evaluation Platform for the ISL6299A Charger
- The Center Square Suggesting the Space Saving Advantage of the Typical Components Assembly
- Cradle Input Accepts Voltage up to 28V
- Flexible Power Connectors Each with a Hook and a Solder Pad Providing Variety to Users
- USB Port On Board Accepts Power Directly From USB Cable
- Convenient Jumpers for Programming the Charge Current, Charge Mode, and for Current Measurement
- 3.5 x 2.5 Square Inches Board Size Handy for Evaluation
- Thermal Vias in the Thermal Pad Similar To Customers' Thermally Enhanced Environment
- On-Board LEDs for Input $\overline{\text{PPR}}$ and $\overline{\text{CHG}}$ State Indication

What is Needed

The following instruments will be needed to perform testing:

- Power supplies:
 - 1) PS1: DC 30V/2A
 - 2) PS2: DC 10V/2A
 - 3) PS3: DC 10V/2A
- DC Electronic load: 20V/2A
- Multimeters
- Function generator
- Oscilloscope
- Cables and wires

Quick Setup Guide (Refer to Figure 1)

DO NOT APPLY POWER UNTIL STEP 5

For Cradle Input:

- Step 1: Connect a 5V supply PS1 to CRDL input (J1, upper +) with the current limit set at 1.3A
- Step 2: Connect a 3.7V supply PS3 to BAT output (J2, upper +) with the current limit set at 1.3A
- Step 3: Connect a current meter to JP6 as shown in Figure 1
- Step 4: Connect the dc electronic load of 1.2A to BAT (J2, upper +)
- Step 5: Insert a jumper shunt on JP2 and JP3, all other jumper shunts are not installed
- Step 6: Turn on Power Supplies and dc electronic load, adjust the power supply PS3 such that the voltmeter V2 reads 3.7V
- Step 7: Both the red and the green LEDs should be on, indicating power on and charging condition
- Step 8: The current meter I2 should read about 0.26A as the charging current
- Step 9: Insert a jumper shunt on JP5 and the current meter I2 should read about 0.55A charging current
- Step 10: Insert a jumper shunt on both JP5 and JP7, the current meter I2 should read about 0.95A charging current
- Step 11: Remove the jumper shunt on JP3 and apply a 3.3V supply, positive to pin 1 (at the right) of JP3, negative to GND
- Step 12: Slowly reduce the dc electronic load current until the green LED turns off, the current meter I2 should read about 84mA EOC current
- Step 13: Insert a jumper shunt on JP4 and repeat Step 11, the current meter I2 should read 40mA EOC current

For USB Input:

- Step 1: Connect a 5V supply PS2 to USB with the current limit set at 0.7A
- Step 2: Connect a 3.7V supply PS3 to BAT (upper +) with the current limit set at 0.7A
- Step 3: Connect the dc electronic load of 0.6A to BAT (upper +)
- Step 4: Install a jumper shunt on JP 8 to USBON position
- Step 5: Turn on Power Supplies and dc electronic load, adjust the power supply PS3 such that the voltmeter V2 reads 3.7V
- Step 6: Both the red and the green LEDs should be on, indicating power on and charging condition
- Step 7: The current meter I2 should read about 0.38A charging current
- Step 8: Remove the jumper shunt on JP3 and apply a 3.3V supply, positive to pin 1 (at the right) of JP3, negative to GND
- Step 9: Slowly reduce the electronic load current until the green LED turns off, the current meter I2 should read about 75mA EOC current

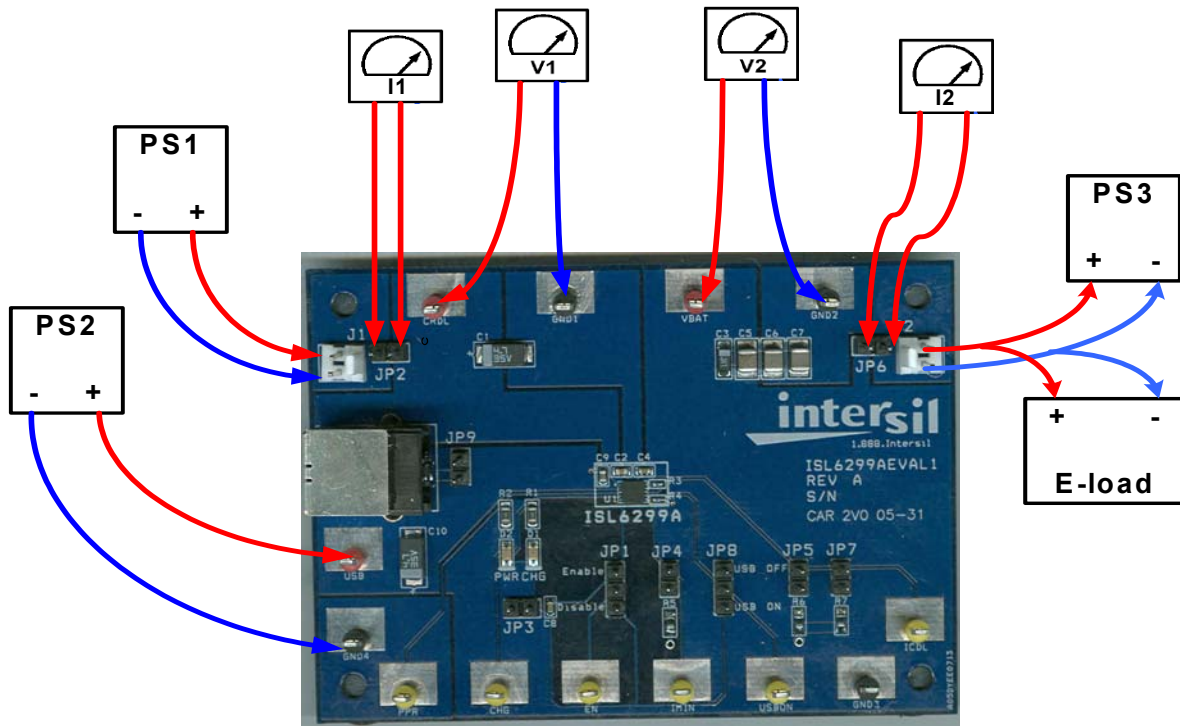

FIGURE 1. CONNECTION OF INSTRUMENTS

Description of Jumper Settings

JP1 - Connects the \overline{EN} pin to a pull-up voltage or GND. The pull-up voltage is either the BAT voltage (When a shunt is installed on JP3) or an external 3.3V power source (when the shunt on JP3 is removed and a +3.3V supply is connected to pin 1(at the right) of JP3. If there is no shunt installed on JP1, the \overline{EN} pin is internally pulled down to logic LOW, which enables the charger. If a shunt is installed across the two jumper pins labeled as “Enable”, the \overline{EN} pin is driven to logic LOW, the charger is enabled, same as floating. If the shunt is installed across the two jumper pins labeled as “Disable” and the pull-up voltage is above 2V, the \overline{EN} pin is driven to logic HIGH, which disables the charger.

JP2 - A shunt installed on JP2 connects the input source from connector J1 to the circuit if input current measurement is not needed. The shunt can be replaced by a current meter if input current measurement is needed, as shown in Figure 1.

JP3 - Selects the power source for logic pull-up and the LED supply. If a shunt is installed, the BAT voltage is selected as the power source. If the shunt is removed, an external power supply of +3.3V can be connected from Pin1 (at the right) to GND to provide the pull-up and LED supply power. The purpose is to exclude the extra current through the charger when characterizing small currents such as EOC and quiescent currents.

JP4 - Parallels an additional 316K resistor to the IMIN pin (total R_{IMIN} = 158K), such that the End-of-Charge Current will be increased to 84mA (R_{IMIN} is 316K and the EOC current is 40mA without the shunt).

JP5 - Parallels an additional 57.6K resistor to the ICDL pin (total RICDL = 28.8K), such that the cradle charge current will be increased to 0.55A (R_{IREF} is 57.6K and the charge current is 0.26A if the shunts on both JP5 and JP7 are removed).

JP6 - A shunt installed on JP6 connects the BAT pin to the output connector J2 if output current measurement is not needed. The shunt can be replaced by a current meter if output current measurement is needed as shown in Figure 1.

JP7 - Parallels an additional 57.6K resistor to the ICDL pin (total RICDL = 19.2K), such that the cradle charge current will be increased to 0.95A.

JP8 - ON/OFF control for USB input. Install a jumper shunt on USB OFF position to turn off the USB charge but has no impact on the cradle input charge.

JP9 - A shunt installed on JP9 connects the input source from the USB port connector to the USB pin if a USB port is used for the evaluation.

TABLE 1. JUMPER SETTING SUMMARY

JUMPER	POSITION	FUNCTION
JP1	Shunt on Disable	Charger disabled
	Shunt on Enable	Charger enabled
	Shunt not installed	Charger enabled
JP2	Shunt installed	Connects input source at J1 to CRDL pin
JP3	Shunt installed	Select BAT as the pull-up source
JP4	Shunt installed	Sets CRDL EOC current to 84mA
JP5	Shunt installed	Sets CRDL charging current to 0.55A, if shunt on JP7 is not installed
JP6	Shunt installed	Connects BAT to J2
JP7	Shunt installed	Sets CRDL charging current to 0.95A, if shunt on JP5 is also installed
JP8	Shunt on USB OFF	Turns off USB charge
	Shunt on USB ON	Turns on USB charge
	Shunt not installed	Turns off USB charge
JP9	Shunt installed	Connects input source from USB port connector to USB pin

Board Design

Schematic

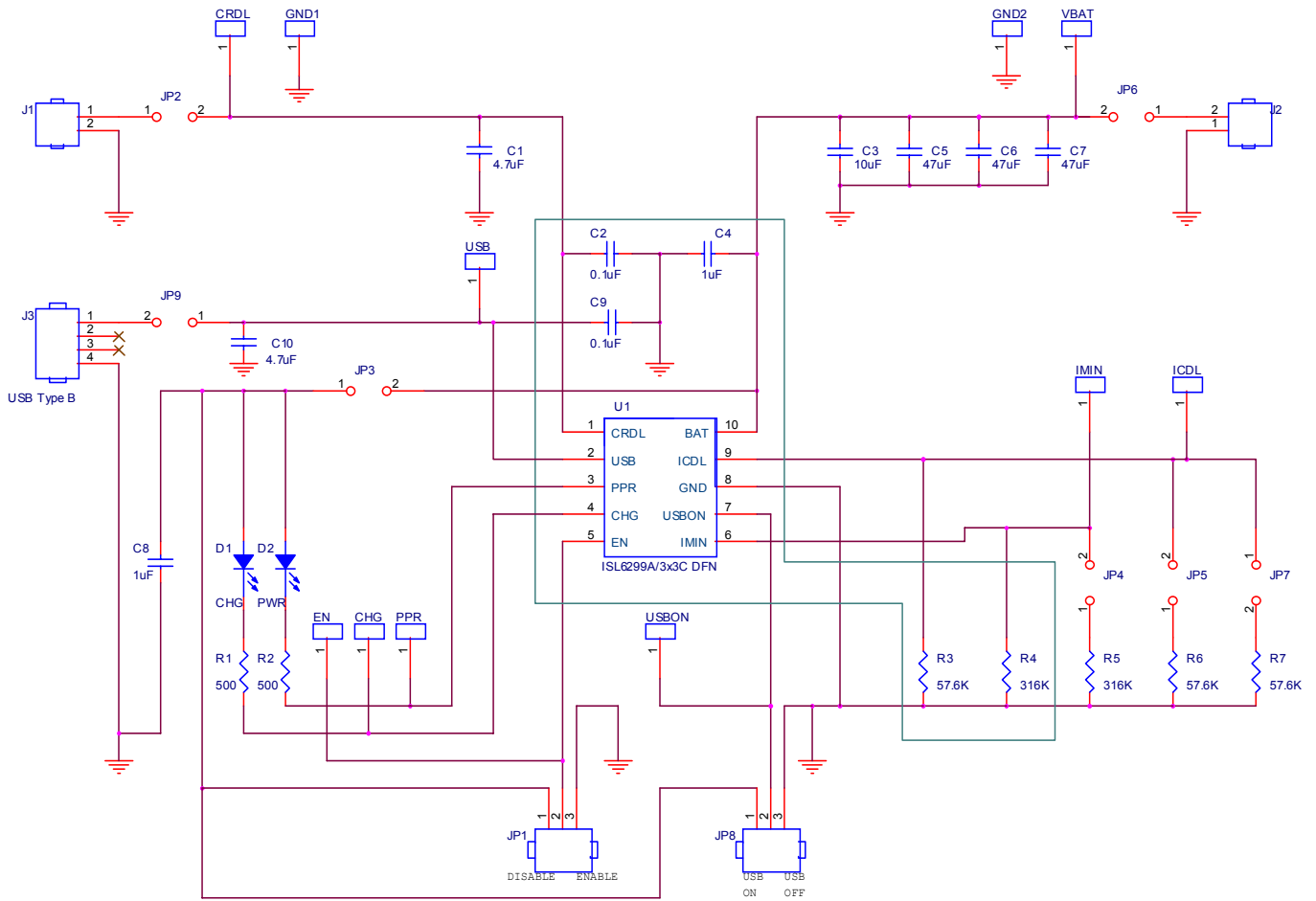

FIGURE 2. SCHEMATIC

Application Note 1170

TABLE 2. ISL6299AEVAL1 BILL OF MATERIALS

ITEM	QTY	REFERENCE	PART DESCRIPTION	PCB FOOTPRINT	PART NUMBER	VENDOR
1	1	U1	ISL6299A Charger IC	3x3C DFN	ISL6299A	Intersil
2	2	R1, R2	470Ω, 5%, 1/8W Resistor	0805	ERJ-6GEYJ471V	Panasonic
3	1	R3	57.6K, 1%, 1/16W Resistor	0402	ERJ-2RKF5762X	Panasonic
4	1	R4	316K, 1%, 1/16W Resistor	0402	ERJ-2RKF3163X	Panasonic
5	1	R5	316K, 1%, 1/8W Resistor	0805	ERJ-6ENF3163V	Panasonic
6	2	R6, R7	57.6K, 1% 1/8W Resistor	0805	ERJ-6ENF5762V	Panasonic
7	2	C1, C10	4.7μF, 35V, Tantalum	6032	ECS-T1VC475R	Panasonic
8	2	C2, C9	0.1μF, 50V, X7R Ceramic	0603	C1608X7R1H104K	TDK
9	1	C3	10μF, 6.3V, Tantalum	0603	ECS-T0JY106R	Panasonic
10	2	C4, C8	1.0μF, 6.3V, X5R Ceramic	0603	ECJ-1VB0J105K	Panasonic
11	3	C5, C6, C7	47μF, 6.3V, X5R Ceramic	1210	ECJ-4YB0J476M	Panasonic
12	2	J1, J2	2.54mm Center Header, 2ckt		22-11-2022	Molex
13	3	CRDL, USB, VBAT	Test point, Red		5010	Keystone
14	6	EN, CHG, PPR, IMIN, USBON, ICDL	Test point, Yellow		5014	Keystone
15	4	GND1, GND2, GND3, GND4	Test point, Black		5011	Keystone
16	7	JP2, JP3, JP4, JP5, JP6, JP7, JP9	2.54mm header, 2ckt		22-28-4020	Molex
17	2	JP1, JP8	2.54mm header, 3ckt		22-28-4030	Molex
18	1	D1	Green LED	0805	SML-LXT0805GW-TR	Lumex Opto
19	1	D2	Red LED	0805	SML-LXT0805IW-TR	Lumex Opto
20	1	J3	Type B, Female, USB		787780-1	Tyco Elec

PCB Layout

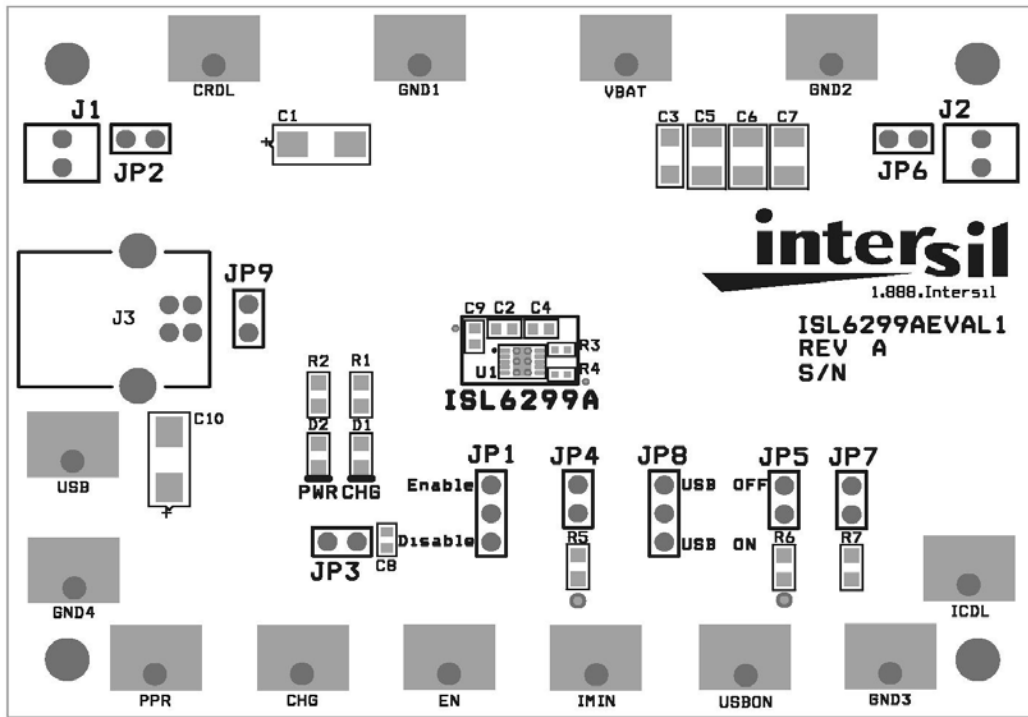

SILK LAYER

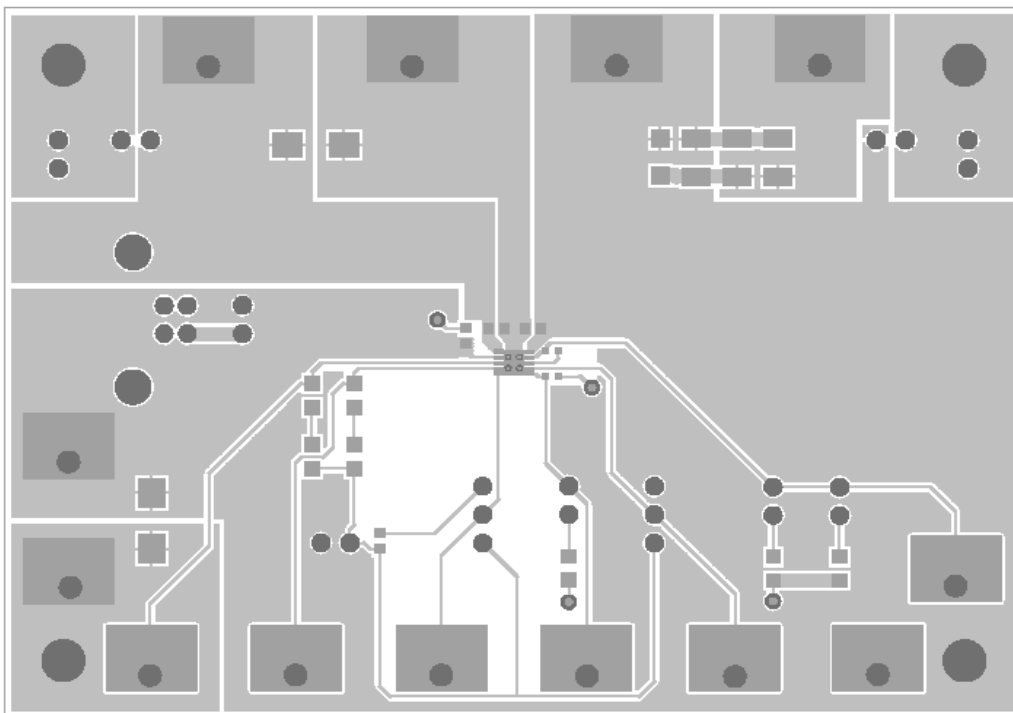

TOP LAYER

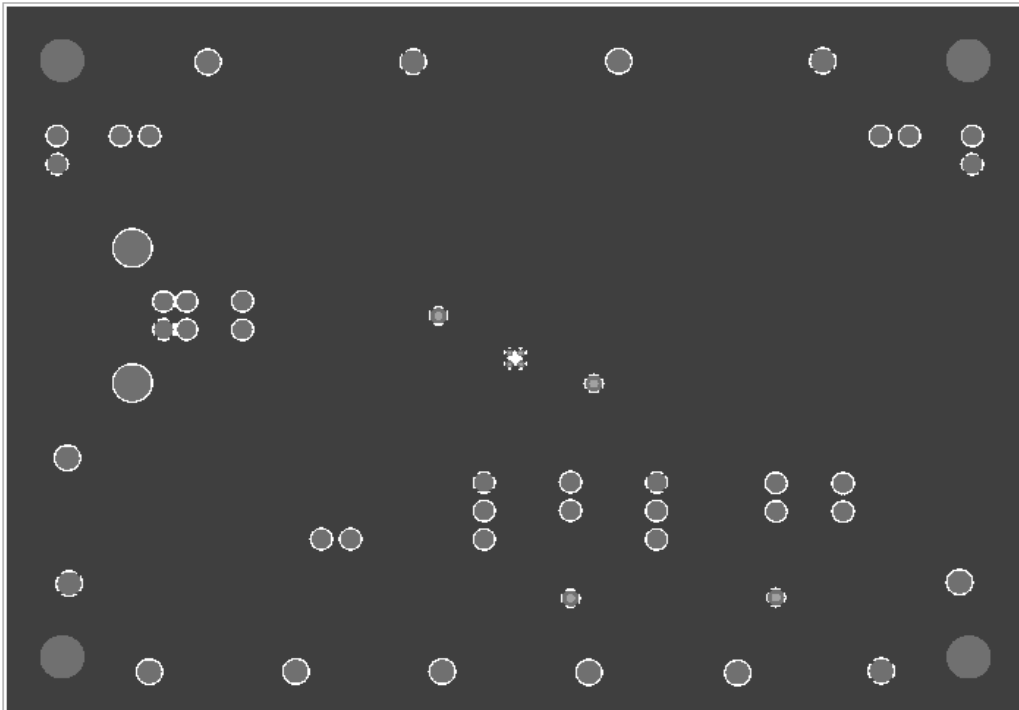

BOTTOM LAYER

All Intersil U.S. products are manufactured, assembled and tested utilizing ISO9000 quality systems.
Intersil Corporation's quality certifications can be viewed at www.intersil.com/design/quality

Intersil products are sold by description only. Intersil Corporation reserves the right to make changes in circuit design, software and/or specifications at any time without notice. Accordingly, the reader is cautioned to verify that data sheets are current before placing orders. Information furnished by Intersil is believed to be accurate and reliable. However, no responsibility is assumed by Intersil or its subsidiaries for its use; nor for any infringements of patents or other rights of third parties which may result from its use. No license is granted by implication or otherwise under any patent or patent rights of Intersil or its subsidiaries.

For information regarding Intersil Corporation and its products, see www.intersil.com