

ZSSC3281

The calibration DLL file described in this document is created to expedite the calibration process for the ZSSC3281. Section 1 provides a short overview of the main calibration steps using the file. Section 3 describes how to implement a DLL (CalibrationL6.DLL) in customer-specific software.

**Contents**

**1. Calibration Sequence ..... 2**

1.1 Set-up and Initialization ..... 3

    1.1.1. Assigning a Unique Identification Number to the IC ..... 3

    1.1.2. Analog Front End Configuration ..... 3

    1.1.3. Temperature Configuration ..... 4

1.2 Data Collection ..... 4

    1.2.1. Data Collection by Raw Measurement Requests ..... 6

1.3 Coefficient Calculations ..... 8

1.4 Programming CCP ..... 8

1.5 Verification ..... 9

**2. CalibrationL6.DLL ..... 9**

2.1 DLL Setup ..... 9

2.2 DLL Use ..... 10

    2.2.1. Using Customer Default Values as Coefficients ..... 10

2.3 CalibrationL6.DLL Application Programming Interface (API) ..... 10

    2.3.1. Constants Used with CalibrationL6.DLL ..... 10

    2.3.2. Conversion Routines ..... 12

    2.3.3. Coefficients Calculation ..... 14

    2.3.4. Verification Routine ..... 16

**3. Glossary ..... 19**

**4. Revision History ..... 19**

**Figures**

Figure 1. AFEs and Signal Paths ..... 2

Figure 2. Calibration Flow Chart ..... 3

Figure 3. Calibration Point Locations for Selected Calibration Methods ..... 5

Figure 4. Assignment Input Resistive Range to SSC-output ..... 7

Figure 5. Raw Data Handling for Coefficient Calculation (DLL) ..... 8

**Tables**

Table 1. Calibration Types ..... 4

Table 2. ZSSC3281 Coefficients CCP Addresses ..... 8

Table 3. Overview of the Routines ..... 12

Table 4. Parameter Bridge Routines ..... 12  
 Table 5. Overview of the Routines ..... 13  
 Table 6. Parameter Temperature Routines ..... 14  
 Table 7. Overview of the Routine ..... 14  
 Table 8. Parameter CalculateCoefficients Function ..... 16  
 Table 9. Parameter BackClacRawTemp/BackCalcRawBridge Functions ..... 18

# 1. Calibration Sequence

A typical calibration flow for the ZSSC3281 contains five steps in the following order:

1. Set-up and initialization
2. Data collection
3. Coefficient calculation
4. Memory programming
5. Verification

The recommended approach for data collection with the ZSSC3281 can be performed using the raw measurement commands described in section 1.2.1.2, which requires a simpler initialization of the IC's memory (customer ID and AFE setup).

The ZSSC3281 has two Analog Front Ends (AFEs); the calibration sequence must be applied separately for Sensor 1 + Temp Ch1, Sensor 2 + Temp Ch2, and Temp Ch3 (see the overview diagram in Figure 1).

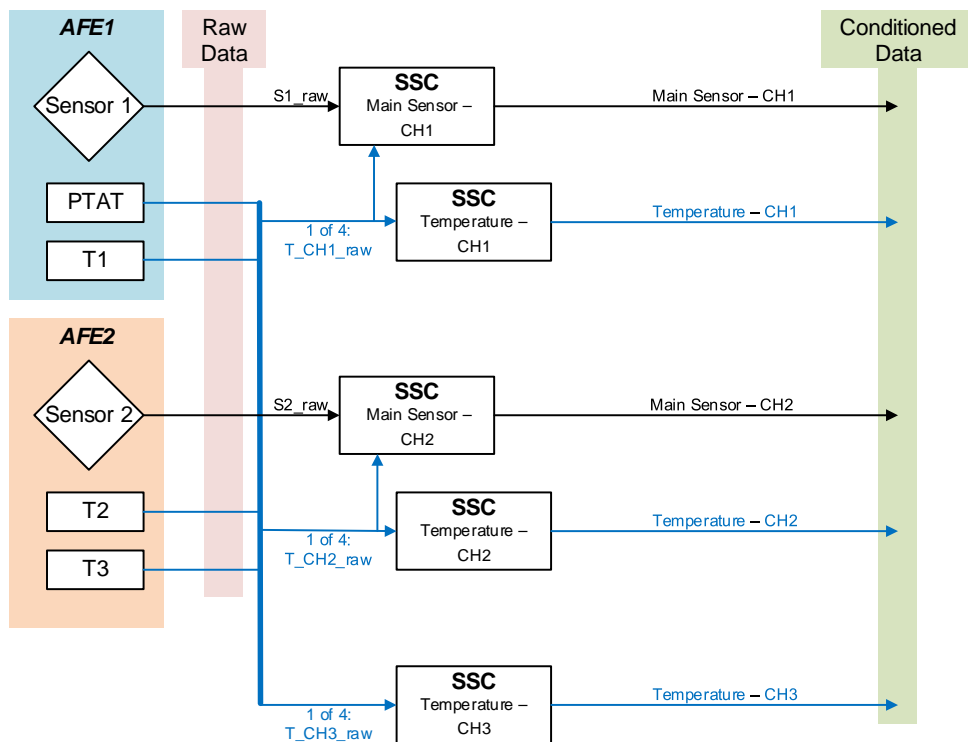

Figure 1. AFEs and Signal Paths

For a more detailed calibration flow graph, see Figure 2.

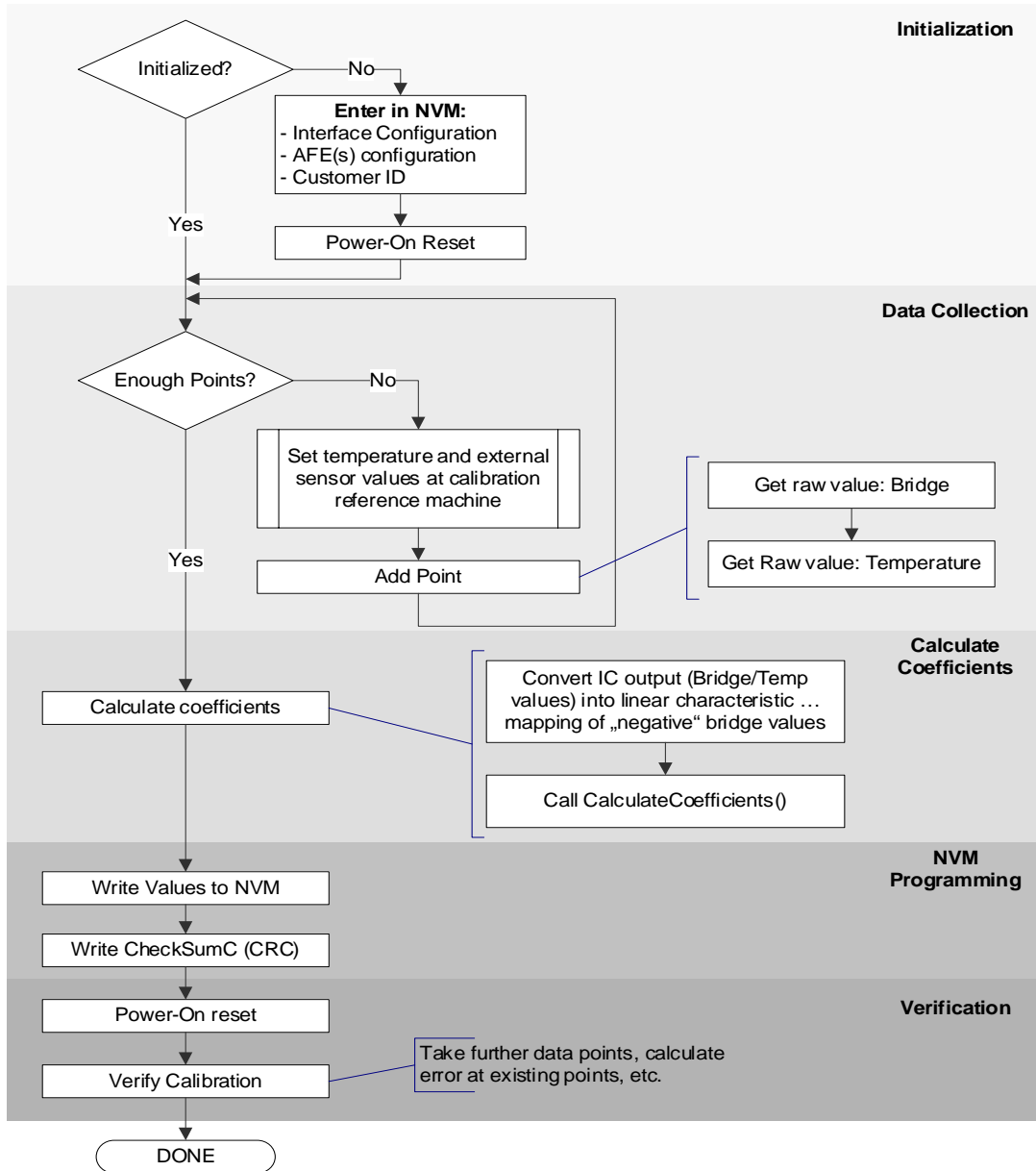

Figure 2. Calibration Flow Chart

## 1.1 Set-up and Initialization

### 1.1.1. Assigning a Unique Identification Number to the IC

This identification is programmed in the IC's memory and can be used as an index in the database stored on the calibration PC. This type of a database can contain all the raw values of external sensor readings (and temperature readings if applied, or vice versa) for that part, as well as the according reference values for the calibration. For a detailed description of the registers Cust\_ID0 (0xFD) and Cust\_ID1 (0xFE) dedicated to the customer for his product identification, see the *ZSSC3281 Datasheet*.

### 1.1.2. Analog Front End Configuration

Before useful raw data can be collected from the IC, the circuitry must be initialized. The initialization step involves setting the AFE (Analog Front End) configuration bits for the end application and optionally programming the math coefficients to their default value. For detailed description for the single parameters of the AFE, and for the default settings of the AFE parameters and coefficients, which have been already programmed during the wafer test, see the *ZSSC3281 Datasheet*.

### 1.1.3. Temperature Configuration

For a possible temperature measurement with the IC-internal temperature sensor, the default configuration is programmed into the temperature configuration registers. These default settings allow the full temperature range of -40°C to +125°C to be used.

## 1.2 Data Collection

The minimum number of calibration points used depends on the precision required and the behavior of the resistive bridge in use (it is normally between two and seven). There is no maximum number of calibration points that can be used; in general, taking more calibration points results in a better calibration.

Descriptions of the standard set of calibration points are displayed in Figure 3.

- 2-point calibration can be used either to:
  - Obtain only a gain and offset terms for bridge compensation with no temperature compensation for either term
  - Obtain only a gain and offset terms for temperature compensation, without using any external sensor
- 3-point calibration can be used either to:
  - Obtain the additional term SOT for 2<sup>nd</sup> order correction for the bridge (SOT\_sens), but no temperature compensation of the bridge output
  - Obtain the additional term SOT for 2<sup>nd</sup> order correction for the temperature (SOT\_temp); temperature only is compensated, without using any external sensor
- 4-point calibration can be used to obtain bridge offset and gain, and both the Tco term and the Tcg term, which provides 1<sup>st</sup> order temperature compensation of the bridge offset and gain term. Additionally, the temperature sensor's offset and gain can be compensated based on the same calibration points.
- 5-point calibration can be used to obtain bridge sensor's gain, offset and 2<sup>nd</sup>-order term, Tco (bridge sensor related temperature offset term) and 2<sup>nd</sup>-order term that provides correction applied to the bridge's temperature coefficient's offset. Additionally, the temperature sensor's offset, gain and 2<sup>nd</sup>-order nonlinearity can be compensated based on the same calibration points.
- 6-point calibration can be used to obtain bridge sensor's gain, offset, Tcg, Tco, SOT\_tco, and SOT\_tcg. Additionally, the temperature sensor's offset, gain and 2<sup>nd</sup>-order nonlinearity can be compensated based on the same calibration points.
- 7-point calibration can be used to obtain the complete set of supported signal correction coefficients for the sensor bridge and IC-internal temperature sensor.

**Table 1. Calibration Types**

Type	Calculated Coefficients <sup>[1]</sup>	Required Number of Data Points	
		Bridge	Temp
2 Points	OFFSET_S, GAIN_S	2	0
2 Points	OFFSET_T, GAIN_T	0	2
3 Points	OFFSET_S, GAIN_S, SOT_S	3	0
3 Points	OFFSET_T, GAIN_T, SOT_T	0	3
4 Points	OFFSET_S, GAIN_S, TCO, TCG, OFFSET_T, GAIN_T	2	2
5 Points	OFFSET_S, GAIN_S, TCO, OFFSET_T, GAIN_T, SOT_TCO, SOT_S, SOT_T	3	3
6 Points	OFFSET_S, GAIN_S, TCO, TCG, OFFSET_T, GAIN_T, SOT_TCO, SOT_TCG, SOT_T	2	3
7 Points	OFFSET_S, GAIN_S, TCO, TCG, OFFSET_T, GAIN_T, SOT_TCO, SOT_TCG, SOT_T, SOT_S	3	3

1. Coefficients notation as used in the Calibration.dll / Calibration.h.

- Gain\_S – External Sensor/Bridge gain term
- Offset\_S – External Sensor/Bridge offset term
- Tcg – Temperature coefficient gain term
- Tco – Temperature coefficient offset term
- SOT\_tcg – Second-order term for Tcg non-linearity
- SOT\_tco – Second-order term for Tco non-linearity
- SOT\_sens – Second-order term for bridge non-linearity
- Gain\_T – Gain coefficient for temperature
- Offset\_T – Offset coefficient for temperature
- SOT\_T – Second-order term for temperature source non-linearity

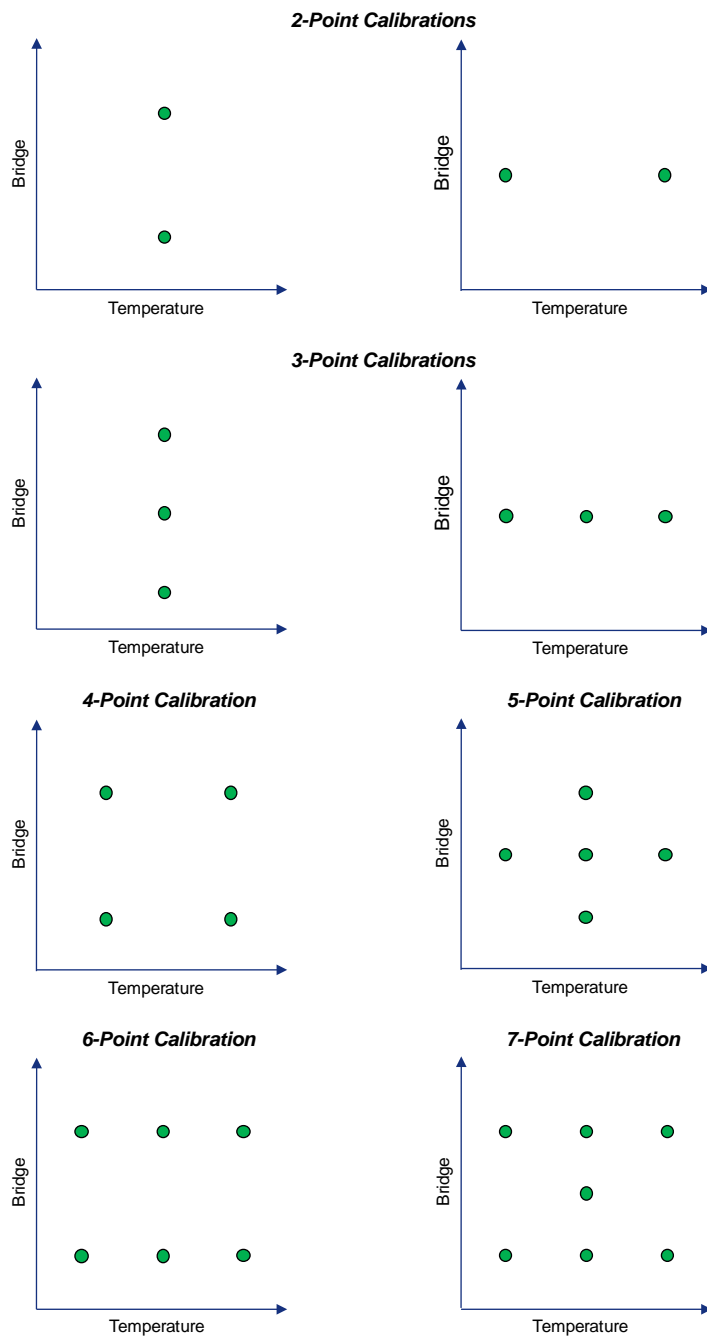

Figure 3. Calibration Point Locations for Selected Calibration Methods

Figure 3 shows the expected, recommended placement of calibration points for the different calibration options. The order of the points taken is not important; however, the number of points per temperature must be followed or the calibration may fail. It is important to keep the calibration points as orthogonal as possible to maximize calibration accuracy.

In addition, the provided calibration DLL can also generate other subsets and combinations of calibration coefficients based on calibration points at different locations than described in Figure 3.

### 1.2.1. Data Collection by Raw Measurement Requests

The number of unique points (external sensor and/or temperature) at which calibration must be performed generally depends on the requirements of the application and the behavior of the resistive bridge in use. The minimum number of points required is equal to the number of bridge/temperature coefficients to be calculated. For a full calibration resulting in values for all seven possible bridge coefficients and three possible temperature coefficients, a minimum of seven pairs of bridge with temperature measurements must be collected.

#### 1.2.1.1. Definition of Reference Values for Raw Measurements

The reference points for the resistive sensor calibration are usually defined in percent in relation to the full target application range. After that, they must be converted into digital value relative to the full scale (FS) output of 24-bit, by a given function in the DLL.

The reference values for the raw temperature measurements are defined in degree Celsius (°C). In combination with user-defined temperature limits (also in °C), the reference input for each point is then converted into the according digital reference value for the DLL.

For example, defining pressure reference points for calibration dependent on a customer's target range can be the following:

- Customer's target application range: 0 to 16bar
- Customer's pressure reference points: 2bar/6bar/14bar.
- Exact assignment would be:
  - 0bar → 0% of the range
  - 16bar → 100% of the range
- The defined reference points have the following assignments:
  - 2bar → 12.5% of the range
  - 6bar → 37.5% of the range
  - 14bar → 87.5% of the range
- To add buffers for parasitic impact and to have integer percentage values for the calibration, it is recommended to change the points slightly as follows:
  - 2bar → 15% of the range
  - 6bar → 35% of the range
  - 14bar → 85% of the range

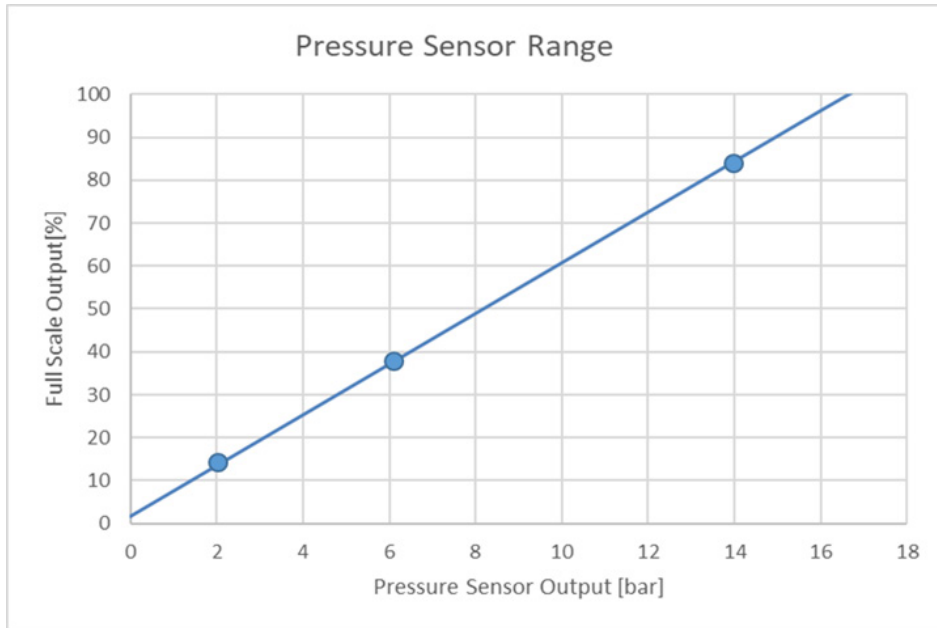

**Figure 4. Assignment Input Resistive Range to SSC-output**

To obtain the potentially best and most robust coefficients, it is recommended that measurement pairs (temperature vs. pressure) are collected near the outer corners of the intended operation range or at points that are located far from each other. It is essential to provide highly precise reference values as nominal, expected values. The measurement precision of the external calibration-measurement equipment must be ten times more accurate than the expected ZSSC3281 output precision after calibration to avoid precision losses caused by the nominal reference values (i.e., resistive sensor signal and temperature deviations).

*Note:* There is an inherent redundancy in the seven resistive sensor-related and three temperature-related coefficients. Since the temperature is a necessary output (which also needs correction), the temperature-related information is mathematically separated, which supports faster and more efficient calculations during the normal usage of the sensor-IC system.

**1.2.1.2. Raw Measurement Commands**

Before data collection, it is recommended to find the optimal AFE configuration for the applied sensor and the target voltage input range, and then program it to the CCP configuration registers (for a description of registers from 0x13 to 0x1C, see the *ZSSC3281 Datasheet*). After AFE configuration, raw data can be acquired.

For data collection, the command A7<sub>HEX</sub> must be used: it returns measurements raw data values for sensors and temperatures for all channels activated.

**1.2.1.3. Raw Data Output**

The raw data measurement results are always MSB (Most Significant Bit)-aligned. The internal temperature sensor has a preconfigured setup with an ADC resolution of 14 bits.

*Note:* In cases of the use of measurements from the third temperature channel, note that the device provides these in a 32-bit format. The 8 least significant should be discarded and the remaining 3 bytes contains raw data MSB aligned, and then can be processed as data relevant to the other channels.

In order to adapt both resistive and temperature raw values to the expected format (integer representation, 24-bit, MSB-aligned in the range of -2<sup>23</sup>..2<sup>23</sup> in), they must be converted from the two's complement representation to integer values in a range from -2<sup>23</sup>..2<sup>23</sup>.

Figure 5 summarizes the recommended raw data process before passing it to the *CalculateCoefficients* function of the DLL.

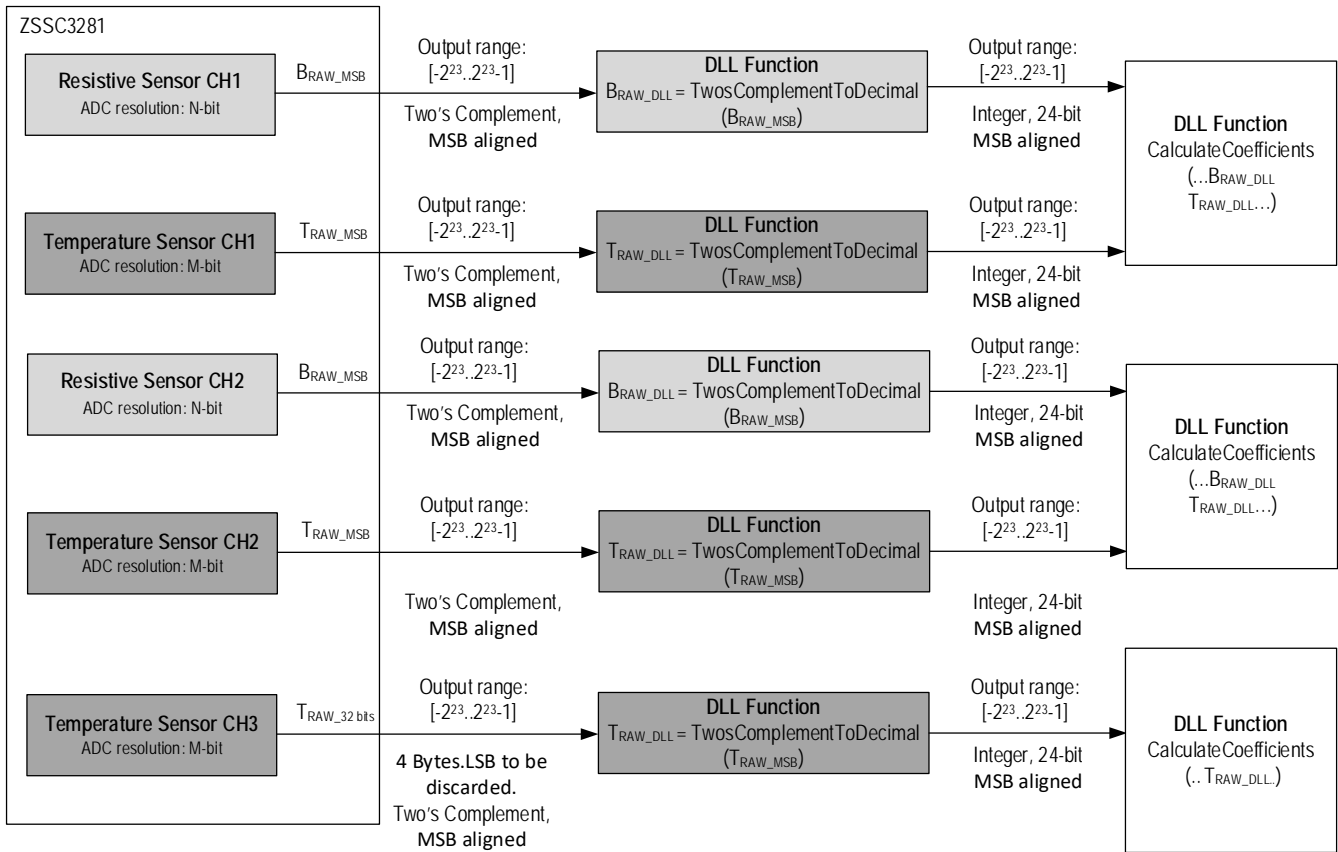

Figure 5. Raw Data Handling for Coefficient Calculation (DLL)

### 1.3 Coefficient Calculations

The coefficients are calculated after all calibration data points are collected. The DLL exposes a C code interface and can be used directly from code (see section 2 for details). Features of the DLL are:

- Coefficient calculation
- Verification at calibration points
- Extended range verification

### 1.4 Programming CCP

After the coefficients are calculated, they must be written to the CCP. The following table lists the commands necessary to program the coefficients to the according registers. Every coefficient is saved in the CCP in a 32-bit register; each coefficient is a 24-bit wide value. Examples displayed in the following sections of the document are based on Main Sensor Ch1 and Temperature Sensor Ch1. Other channels can be considered equivalent. Sensor Temperature Ch3 measurement requires upfront formatting to 24 bits as explained in Section 1.2.1.3.

Table 2. ZSSC3281 Coefficients CCP Addresses

Register [Hex]	Data from Coefficients for the According Register	Description	Provided by
4D	coefficients[INDEX_OFFSET_S]	Offset_S[31:0]	DLL
4E	coefficients[INDEX_GAIN_S]	Gain_S[[31:0]	DLL
53	coefficients[INDEX_TCG]	Tcg[31:0]	DLL
51	coefficients[INDEX_TCO]	Tco[31:0]	DLL



Register [Hex]	Data from Coefficients for the According Register	Description	Provided by
52	coefficients[INDEX_SOT_TCO]	SOT_tco[31:0]	DLL
54	coefficients[INDEX_SOT_TCG]	SOT_tcg[31:0]	DLL
4F	coefficients[INDEX_SOT_S]	SOT_sens[31:0]	DLL
61	coefficients[INDEX_OFFSET_T]	Offset_T[[31:0]	DLL
62	coefficients[INDEX_GAIN_T]	Gain_T[31:0]	DLL
63	coefficients[INDEX_SOT_T]	SOT_T[31:0]	DLL
<p><b>Assignment to the 32 bit register of coefficients calculated by the dll</b></p> <pre> if (coefficients[INDEX_OFFSET_S] &lt; 0) Offset_S = (-coefficients[INDEX_OFFSET_S]   0x800000); else Offset_S = coefficients[INDEX_OFFSET_S];  if (coefficients[INDEX_GAIN_S] &lt; 0) Gain_S = (coefficients[INDEX_GAIN_S]   0x800000); else Gain_S = coefficients[INDEX_GAIN_S]; </pre> <p><b>Numerical example:</b></p> <pre> // results from coefficients calculation coefficients[INDEX_OFFSET_S] = -520831 // = 0x0087F27F (32 bit sign-magnitude //representation) coefficients[INDEX_GAIN_S] = 5880722 // = 0x0059BB92 (32 bit sign-magnitude //representation) </pre>			

## 1.5 Verification

The DLL interface provides verification at calibration time (see section 2.3.4). To verify if the results are consistent with expected results, also perform an online verification at a different bridge measurand / temperature combination than was used for calibration.

## 2. CalibrationL6.DLL

The CalibrationL6.DLL's properties, interfacing, and variable declaration, and the available routines with the respective returns of the available methods, are characterized in detail. The main focus in this document is to enable the user to integrate the DLL in a customer software environment for production purposes.

### 2.1 DLL Setup

Complete the following setup steps to use the CalibrationL6.DLL in a user program:

1. Declare all functions to be used from the DLL:
  - In C/C++, link *CalibrationL6.lib* into the final executable.
  - In VB (Visual Basic), add *CalibrationL6.DLL* as a reference and verify that it is in the path.
2. Create *CalibrationL6.h* that must contain the same declarations for the functions used in *CalibrationL6.DLL*. The user's program must be set up to use Windows™ calling conventions (stdcall), not "C" style calling conventions (cdecl).

All functions listed in section 2 can be called as if they were local functions.

## 2.2 DLL Use

CalibrationL6.DLL typically is used for the following calibration steps:

1. Data Conversion – All raw and target data input for both bridge and temperature (if applicable) must be converted into the correct format (see section 1.2).
2. Coefficient Calculation – The converted data along with control information is passed to the CalculateCoefficients method which generates all necessary coefficients (see section 2.3.3).
3. Verification – The coefficients are verified both for accuracy and proper operation across the entire region of operation. The CalibrationL6.DLL provides methods to do this verification offline (see section 2.3.4).

### 2.2.1. Using Customer Default Values as Coefficients

The *CalibrationL6.DLL* library supports calibration using customer-calculated default values. These values can be applied to all calibrations without recalculating each time, allowing one less calibration point for every used default value. The pre-condition for using customer default values is a known, repeatable sensor characteristic. The result of a calibration using default values is always less accurate than a complete calibration. To use a default value during calibration, do not select coefficient for calculation.

## 2.3 CalibrationL6.DLL Application Programming Interface (API)

### 2.3.1. Constants Used with CalibrationL6.DLL

Within CalibrationL6.DLL many different enumerations are used to clarify the control and separation of data going to and from the DLL.

#### 2.3.1.1. COEFFICIENT\_COUNT

COEFFICIENT\_COUNT is a constant that represents the number of coefficients. All coefficient arrays passed to CalibrationL6.DLL are expected to be of size COEFFICIENT\_COUNT.

Example: Declaration of an array of integers for the coefficients and initialize the array to 0.

```
int coefficients[COEFFICIENT_COUNT] = {0}; //c compiler will 0 fill remaining entries
```

#### 2.3.1.2. Calibration Type

The programmable coefficients have the listed flag values (see the following C code declaration) in the DLL. The most common combinations of coefficients are shown in the source code *Example* of this section. The type of calibration desired is indicated through the coefficients selected for calibration. For best results, use the pre-defined combinations. The coefficients can be individually OR'ed together in order to form other calibration types.

C code declaration:

```
#define CO_OFFSET_S          0x1
#define CO_GAIN_S           0x2
#define CO_TCG              0x4
#define CO_TCO              0x8
#define CO_SOT_TCO          0x10
#define CO_SOT_TCG          0x20
#define CO_SOT_S            0x40
#define CO_OFFSET_T         0x80
#define CO_GAIN_T           0x100
#define CO_SOT_T            0x200
```

Example: The following C code lines show applicable combinations of coefficients and a possible definition of a variable which passes this information validly to the *CalculateCoefficients* method.

```
int errorCode;
int negCoeffs;
```

```

// Variable definition for required coefficients
int P2_S = (CO_OFFSET_S|CO_GAIN_S);
int P3_S = (CO_OFFSET_S|CO_GAIN_S|CO_SOT_S);
int P3_T = (CO_OFFSET_T|CO_GAIN_T|CO_SOT_T);
int P4_S = (CO_OFFSET_S|CO_GAIN_S|CO_TCO|CO_TCG|CO_OFFSET_T|CO_GAIN_T);
int P5_S = (CO_OFFSET_S|CO_GAIN_S|CO_TCO|CO_OFFSET_T|CO_GAIN_T|CO_SOT_TCO|CO_SOT_S|CO_SOT_T);
int P6_S = (CO_OFFSET_S|CO_GAIN_S|CO_TCO|CO_TCG|CO_OFFSET_T|CO_GAIN_T|CO_SOT_TCO|CO_SOT_TCG|CO_SOT_T);
int P7_S =
(CO_OFFSET_S|CO_GAIN_S|CO_TCO|CO_TCG|CO_OFFSET_T|CO_GAIN_T|CO_SOT_TCO|CO_SOT_TCG|CO_SOT_T|CO_SOT_S);
...

// calculate just bridge coefficients -> P3_S
// possible function call
errorcode = CalculateCoefficients(    coefficients,
                                     &negCoeffs
                                     2,
                                     P3_S,
                                     0,
                                     rawBridge,
                                     desiredBridge,
                                     rawDummy,
                                     desiredDummy, /* Not calibrating anything with temp */
                                     );

```

### 2.3.1.3. Indexes for Coefficients

After calculating coefficients, the CalibrationL6.DLL provides them in a certain order in the coefficients array. The access with these indexes returns the signed value of each coefficient.

C code declaration:

```

//INDEXES for coefficients array
#define INDEX_OFFSET_S      0
#define INDEX_GAIN_S       1
#define INDEX_TCG          2
#define INDEX_TCO          3
#define INDEX_SOT_TCO      4
#define INDEX_SOT_TCG      5
#define INDEX_SOT_S        6
#define INDEX_OFFSET_T     7
#define INDEX_GAIN_T       8
#define INDEX_SOT_T        9

```

Example: Accessing the OFFSET\_S coefficient value after calculation with *CalculateCoefficients* method:

```

//assuming int coefficients[COEFFICIENT_COUNT]; has been previously declared
int offset_s = coefficients[INDEX_OFFSET_S];

```

### 2.3.1.4. Sign Flags of the Coefficients

The sign flags allow excluding a certain sign from the representative “sign number,” which contains the sign information for all coefficients. The coefficients themselves are signed, too. This “sign number” makes data processing more comfortable. Gain coefficients do not have a flag for negative presentation; the results are always positive.

C code declaration:

```

//FLAGS for negCoeffs
#define NEG_SOT_S          0x1
#define NEG_SOT_TCO       0x2
#define NEG_SOT_TCG       0x4
#define NEG_SOT_T         0x8
#define NEG_TCO           0x10
#define NEG_TCG           0x20
#define NEG_OFFSET_S      0x40
#define NEG_OFFSET_T      0x80

```

Example:

```
int negSOT_S =0;

//negSOT_S=0 when the coefficient is positive, = 1 when it's negative.
negSOT_S = negCoeffs & NEG_SOT_S;
```

### 2.3.2. Conversion Routines

The following conversion routines are used for translation of an input value into the necessary format to complete the calculations.

#### 2.3.2.1. Bridge Conversion Routines

**Table 3. Overview of the Routines**

Name	Description
ConvertBridgeFromPercent	Converts a percentage value [0,100] into the proper domain for use by <i>CalibrationL6.DLL</i> . 100 percent correspond to the full scale output ( $16777215 = 2^{24}-1$ ) of the 24-bit wide IC output
ConvertBridgeToPercent	Converts result from the IC (corrected measurement) or DLL's calculation domain into a percentage reading for use in error calculations.

The percentage declarations for the bridge input are useful for defining the common range of the measured item (e.g., pressure). For calculation or verification routines listed in sections 2.3.3 and 2.3.4, the sensor inputs must be processed through *ConvertBridgeFromPercent* routine which maps the bridge sensor precentral values (0% to 100%) to the full scale range of 24 bits.

C code declaration:

```
double ConvertBridgeFromPercent(double percent);
```

Returns: The desired (reference) sensor value in counts according to the input in percent.

Example: One calibration input represents the desired and reference value of 10%. To convert this sensor value for valid use in further process of coefficients calculation, this function must be applied:

```
double desired_s1 = ConvertBridgeFromPercent(10.0);
```

*ConvertBridgeToPercent* can be used to convert any output from *CalibrationL6.DLL* back into the percentage domain for error analysis. This routine should be used for the external sensor output after calibration; otherwise the percentage numbers is meaningless.

C code declaration:

```
double ConvertBridgeToPercent(double codes);
```

Returns: The sensor value in percent according to the input in code is provided.

**Table 4. Parameter Bridge Routines**

Parameter	Description
codes	24-bit digital result value from the IC or DLL's calculation (corrected measurement).
percent	Bridge value in percent, referring to the applied measurement range.

2.3.2.2. Temperature Conversion Routines

Table 5. Overview of the Routines

Name	Description
ConvertTempFromDegrees	Converts a Celsius value [-45,150] into the proper domain for use by CalibrationL6.DLL. User entered limit for the maximum temperature corresponds to the full scale output (16777215 = 2 <sup>24</sup> -1) of the 24-bit wide IC output.
ConvertTempToDegrees	Converts result from the IC (corrected measurement) or DLLs domain back into Celsius to use in error calculations or to display values in Celsius.

All “°C” temperature inputs must be run through the *ConvertTempFromDegrees* function before coefficients calculation. It expects a value between [-45, +150°C]. The result in code is saved to the variable, which is passed as first argument as a reference.

C code declaration:

```
__int32 ConvertTempFromDegrees( double *tempInCodes,
                               double tempInDegrees,
                               double minTemp,
                               double maxTemp);
```

Returns: An error code denoting the status of the calculations. 0 is returned if the method passes successfully. 1 is returned if the input parameters are out of the expected ranges.

Example: During calibration, an environmental temperature of 50°C is applied as a calibration point. It must be converted for further coefficient determination. The limits for minimum and maximum temperature must be provided to the function.

```
double desiredTemp;
int errorcode = 0;

errorcode = ConvertTempFromDegrees(&desiredTemp, 50.0, -40.0, 125.0);
```

*ConvertTempToDegrees* can be used to convert a 24-bit temperature as returned by *GetCorrectedTemp* into degrees Celsius.

C code declaration:

```
__int32 ConvertTempToDegrees( double *tempInDegrees,
                              __int32 tempInCodes,
                              double minTemp,
                              double maxTemp);
```

Returns: An error code denoting the status of the calculations. 0 is returned if the method passes successfully. 1 is returned if the input parameters are out of expected ranges.

Example: It is assumed that calibration is performed successfully. The coefficients are calculated and stored in coefficients [COEFFICIENT\_COUNT].

```
double tempCorrectedCodes;
double tempDegreesC;
int errorcode = 0;

tempCorrectedCodes = GetCorrectedTemp(coefficients, 320000);
errorcode += ConvertTempToDegrees(&tempDegreesC, tempCorrectedCodes, -40, 85);
```

Table 6. Parameter Temperature Routines

Parameter	Description
*tempInCodes	Pointer to the variable where the calculated raw temperature value is stored.
tempInDegrees	Temperature in Celsius to be converted to codes.
minTemp	The lower temperature limit of the calibration range, in Celsius.
maxTemp	The upper temperature limit for of the calibration range, in Celsius.

2.3.2.3. Raw Values Conversion

Table 7. Overview of the Routine

Name	Description
TwosComplementToDecimal	Converts a raw measurement value into a signed integer number in the range $[-2^{23}..2^{23}-1]$ .

Raw bridge measurement results are provided from the ZSSC3240 as N-bit two’s complement numbers, where N is the customer configured ADC-resolution. For a proper input to the *CalculateCoefficients* function or for common display in as a signed integer values, they must be converted accordingly (for more information, see section 1.2.1.3).

For the conversion from a 24-bit two's complement value to a 24-bit decimal value, the *TwosComplementToDecimal* function can be used.

C code declaration:

```
__int32 TwosComplementToDecimal (__int32 input);
```

Returns: Digital value in signed magnitude representation.

Example:

```
__int32 testTwosComp = 0;
__int32 signMagn = 0;

testTwosComp = 0xfffff6;
signMagn = TwosComplementToDecimal(testTwosComp);
// signMagn = -10

testTwosComp = 0x7000A3;
signMagn = TwosComplementToDecimal(testTwosComp);
// signMagn = 7340195

testTwosComp = 0x5;
signMagn = TwosComplementToDecimal(testTwosComp);
// signMagn = 5

testTwosComp = 0x800005;
signMagn = TwosComplementToDecimal(testTwosComp);
// signMagn = -8388603
```

2.3.3. Coefficients Calculation

*CalculateCoefficients* is the main function for doing the actual calibration calculations. It determines a set of coefficients that provides calibrated output based on the provided set of data points. This function provides the calibrated coefficients, which can be used in all the verification methods listed in section 2.3.4.

C code declaration:

```
__int32 CalculateCoefficients(__int32 coefficients[COEFFICIENT_COUNT],
                             __int32 *negCoeffs
                             __int32 numPoints,
                             __int32 selCoeffs,
                             __int32 calType,
                             double *bridgeRaw,
                             double *bridgeDesired,
                             double *tempRaw,
                             double *tempDesired);
```

Returns: An error code denoting the status of the calculations. 0 is passed if the method passes completely.

Before using the *CalculateCoefficients* function, the collected raw data must be converted to the expected format. For more information on the IC-provided measurement data, see section 1.2.

Example:

```
int errorcode = 0;

int numPoints = 2;
int negCoeffs=0;

double rawBridge[2], desiredBridge[2];

// temperature input not relevant
double rawDummy[2] = {NULL,NULL};
double desiredDummy[2] = {NULL,NULL};

int selCoeffs = CO_OFFSET_S | CO_GAIN_S;

// set coefficient array to zero
int coefficients[COEFFICIENT_COUNT] = {0};

// calibration type, default value
int calType = 0;

// raw data as double values
rawBridge[0] = -10000.0;
rawBridge[1] = 8236410.0;

// convert percentage reference values into the digital representative
desiredBridge [0] = ConvertBridgeFromPercent(10.0);
desiredBridge [1] = ConvertBridgeFromPercent(90.0);

// run coefficients calculation
errorcode = CalculateCoefficients(    coefficients,
                                     &negCoeffs,
                                     numPoints,
                                     selCoeffs,
                                     calType,
                                     rawBridge,
                                     desiredBridge,
                                     rawDummy,      /* Not calibrating anything with temp */
                                     desiredDummy   /* Not calibrating anything with temp */
                                     );

/*****resulting coefficients*****/
coefficients[0] = coefficients[INDEX_OFFSET_S] = -1028301
coefficients[1] = coefficients[INDEX_GAIN_S] = 3413303
errorcode = 0
*****/
```

Table 8. Parameter CalculateCoefficients Function

Parameter	Description
coefficients[COEFFICIENT_COUNT]	This array contains the calculated coefficients (functions' return). The array must be zero-filled prior to calling CalculateCoefficients unless using default values.
*negCoeffs	Pointer to the representative sign parameter, with bitwise negative coefficient flags.
numPoints	Number of calibration points used.
selCoeffs	In binary representation, this parameter indicates which coefficient is to be calculated.
calType	The type of calibration desired. A default value of 0 is recommended, which represents the parabolic correction function and provides the best calculation approach.
*bridgeRaw <sup>[1]</sup>	Array of raw sensor values. Must be converted for DLL input and have the length of numPoints. If not calibrating for bridge correction, the array elements can be NULL.
*bridgeDesired <sup>[1]</sup>	Array of target sensor values. Must be converted for DLL input and have the length of numPoints. If not calibrating for bridge correction, the array elements can be NULL.
*tempRaw <sup>[1]</sup>	Array of raw temperature values. Must be converted for DLL input and have the length of numPoints. If not calibrating for temperature correction, the array elements can be NULL.
*tempDesired <sup>[1]</sup>	Array of target temperature values. Must be converted for DLL input and have the length of numPoints. If not calibrating for temperature correction, the array elements can be NULL.

1. The array must have matching indices to the according calibration points.

### 2.3.4. Verification Routine

The function checks whether the DLL calculation produced coefficients, or has a size exceeding the destined dimensions. It is recommended to apply this function after each calculation of coefficients.

C code declaration:

```
__int32 VerifyCoefficients(const __int32 coefficients[COEFFICIENT_COUNT]);
```

Returns: An \_\_int32 error code denoting the status of the calculations: 1 on failure, 0 on success.

Example:

```
int errorcode = 0;
errorcode = VerifyCoefficients(coefficients);

if (errorcode != 0) // coefficients out of range
```

#### 2.3.4.1. GetCorrectedTemp

GetCorrectedTemp calculates the calibrated temperature output based on the given calculated coefficients and a raw temperature value.

C code declaration:

```
double GetCorrectedTemp(const __int32 coefficients[COEFFICIENT_COUNT], double rawTemp);
```

Returns: The calibrated temperature in double-precision floating-point format is provided. It can be converted to Celsius using the *ConvertTempToDegree* function, see section 2.3.2.2.



### 2.3.4.2. GetCorrectedBridge

GetCorrectedBridge calculates the calibrated bridge output based on the given calculated coefficients and raw sensor and raw temperature values.

C code declaration:

```
double GetCorrectedBridge(const __int32 coefficients[COEFFICIENT_COUNT],
                        double rawBridge, double rawTemp);
```

Returns: The calibrated output in double-precision floating-point format is provided. It can be converted to percentage using Bridge Conversion Routines (see section 2.3.2.1).

Example: Assuming a seven point bridge/temperature calibration is accomplished with raw data (rawBridge[], rawTemp[]) and the result of a set of valid coefficients. Then a possible verification of the target accuracy (here: 1.5% for the external bridge sensor and 3°C for temperature) at the calibration points can be done as the following source code shows. Such verification does not include the inaccuracies caused by the sensor and measurement, but the deviations caused by correction calculation.

```
// rawBridge[], rawTemp[] -> contain raw bridge/temperature data
// coefficients[] -> contain a set of valid coefficients
// refTempDeg[] -> contain reference temperature values in degree Celsius
// rawBridgePerc[] -> contain reference pressure values in percent

int errorCode = 0;

double outBridgeCodes, outBridgePerc, outTempCodes, outTempDeg;

// loop over calibration points
for(int i=0; i<3; i++) {

    //Verify Temperature accuracy
    outTempCodes = GetCorrectedTemp(coefficients, rawTemp[i]);
    errorCode += ConvertTempToDegrees(&outTempDeg, outTempCodes, -40.0, 125.0);

    // check ambient temperature accuracy comparing degC values
    // between measured and reference values
    if( fabs(refTempDeg[i]-outTempDeg) > 3.0 ) //ERROR

    outBridgeCodes = GetCorrectedBridge(coefficients, rawBridge[i], rawTemp[i]);
    outBridgePerc = ConvertBridgeToPercent(outBridgeCodes);

    // check external sensor accuracy comparing percentage values
    // between measured and reference values
    if( fabs(outBridgePerc-rawBridgePerc[i]) > 1.5 ){...} //ERROR

};
```

### 2.3.4.3. BackCalcRawTemp

BackCalcRawTemp is the inverse function of GetCorrectedTemp. It calculates the raw temperature value based on the given calculated coefficients and a corrected temperature value.

C code declaration:

```
__int32 BackCalcRawTemp(const __int32 coefficients[COEFFICIENT_COUNT],
                       double *rawTemp, double correctedTempInDeg,
                       double minTemp, double maxTemp);
```

Returns: An error code denoting the status of the calculations. 0 is returned if the method passes successfully. 1 is returned if the input parameters are out of expected ranges.

2.3.4.4. BackCalcRawBridge

BackCalcRawBridge is the inverse function of GetCorrectedBridge. It calculates the raw bridge value based on the given calculated coefficients and a corrected temperature value. Since the correction of bridge values is processing also raw temperature values for specific calibration types, BackCalcRawBridge also expects the passing of it.

C code declaration:

```
__int32 BackCalcRawBridge(const __int32 coefficients[COEFFICIENT_COUNT],
                        double * rawBridge,
                        double correctedBridgeInPerc,
                        double rawTemp);
```

Returns: An error code denoting the status of the calculations. 0 is returned if the method passes successfully. 1 is returned if the input parameters are out of expected ranges.

Example:

```
// rawBridge[], rawTemp[] -> contain raw bridge/temperature data
// coefficients[] -> contain a set of valid coefficients
// caliPoints -> number of calibration points
// T_min,T_max -> temperature calibration limits

double correctedTempInCodes[caliPoints], correctedTempInDegC[caliPoints];
double correctedBridgeInCodes[caliPoints], correctedBridgeInPerc[caliPoints];
double rawT = 0, rawB = 0;

// correction functions applied in this loop calculating corrected output
for (i = 0;i<caliPoints;i++){

    correctedTempInCodes[i] = GetCorrectedTemp(coefficients, rawTemp[i]);
    // convert corrected codes into degree celsius
    ConvertTempToDegrees(&correctedTempInDegC[i], (int)correctedTempInCodes[i], T_min, T_max);

    correctedBridgeInCodes[i] = GetCorrectedBridge (coefficients, rawBridge[i] , rawTemp[i]);
    // convert corrected codes into percent
    correctedBridgeInPerc[i] = ConvertBridgeToPercent(correctedBridgeInCodes[i]);
}

// back calculation functions applied in this loop calculating raw values
// from corrected degree celsius/percentage values
for (i = 0;i<cali_points;i++){

    BackCalcRawTemp(coefficients, &rawT, CorrectedTempInDegC[i], T_min, T_max );
    BackCalcRawBridge(coefficients, &rawB, correctedBridgeInPerc[i], rawT);

    // origin and recalculated raw values should be the same
    // rawTemp[i] == rawT -> True
    // rawBridge[i] == rawB -> True
}
```

Table 9. Parameter BackClacRawTemp/BackCalcRawBridge Functions

Parameter	Description
coefficients[COEFFICIENT_COUNT]	This array contains the applied coefficients.
*rawTemp [1]	Array of raw temperature values (functions' return).
correctedTempInDeg	The corrected temperature measurement output, should be provided in degree Celsius
*rawBridge [1]	Array of raw sensor values. Must be converted for DLL input and have the length of numPoints. If not calibrating for bridge correction, the array elements can be NULL.

Parameter	Description
correctedBridgeInPerc	The corrected bridge measurement output, should be provided in percent
minTemp	The lower temperature limit of the calibration range, in Celsius.
maxTemp	The upper temperature limit for of the calibration range, in Celsius.

1. The array must have matching indices to the according calibration points.

### 3. Glossary

Term	Description
AFE	Analog Front End
API	Application Programming Interface
CMD	Command
CRC	Cyclic Redundancy Check
DLL	Dynamic-Link Library. An executable file that enables programs to share code and resources for completing specific tasks.
FS	Full Scale
GUI	Graphical User Interface
IC	Integrated Circuit
ID	Identifier
LSB	Least Significant Bit
MSB	Most Significant Bit
CCP	Configuration and Calibration Page (non volatile memory)
PC	Personal Computer
SSC	Sensor Signal Conditioner
T	Temperature
VB	Visual Basic

### 4. Revision History

Revision	Date	Description
1.00	Jun 29, 2022	Initial release.

## Notice

1. Descriptions of circuits, software and other related information in this document are provided only to illustrate the operation of semiconductor products and application examples. You are fully responsible for the incorporation or any other use of the circuits, software, and information in the design of your product or system. Renesas Electronics disclaims any and all liability for any losses and damages incurred by you or third parties arising from the use of these circuits, software, or information.
2. Renesas Electronics hereby expressly disclaims any warranties against and liability for infringement or any other claims involving patents, copyrights, or other intellectual property rights of third parties, by or arising from the use of Renesas Electronics products or technical information described in this document, including but not limited to, the product data, drawings, charts, programs, algorithms, and application examples.
3. No license, express, implied or otherwise, is granted hereby under any patents, copyrights or other intellectual property rights of Renesas Electronics or others.
4. You shall be responsible for determining what licenses are required from any third parties, and obtaining such licenses for the lawful import, export, manufacture, sales, utilization, distribution or other disposal of any products incorporating Renesas Electronics products, if required.
5. You shall not alter, modify, copy, or reverse engineer any Renesas Electronics product, whether in whole or in part. Renesas Electronics disclaims any and all liability for any losses or damages incurred by you or third parties arising from such alteration, modification, copying or reverse engineering.
6. Renesas Electronics products are classified according to the following two quality grades: "Standard" and "High Quality". The intended applications for each Renesas Electronics product depends on the product's quality grade, as indicated below.

"Standard": Computers; office equipment; communications equipment; test and measurement equipment; audio and visual equipment; home electronic appliances; machine tools; personal electronic equipment; industrial robots; etc.

"High Quality": Transportation equipment (automobiles, trains, ships, etc.); traffic control (traffic lights); large-scale communication equipment; key financial terminal systems; safety control equipment; etc.

Unless expressly designated as a high reliability product or a product for harsh environments in a Renesas Electronics data sheet or other Renesas Electronics document, Renesas Electronics products are not intended or authorized for use in products or systems that may pose a direct threat to human life or bodily injury (artificial life support devices or systems; surgical implantations; etc.), or may cause serious property damage (space system; undersea repeaters; nuclear power control systems; aircraft control systems; key plant systems; military equipment; etc.). Renesas Electronics disclaims any and all liability for any damages or losses incurred by you or any third parties arising from the use of any Renesas Electronics product that is inconsistent with any Renesas Electronics data sheet, user's manual or other Renesas Electronics document.

7. No semiconductor product is absolutely secure. Notwithstanding any security measures or features that may be implemented in Renesas Electronics hardware or software products, Renesas Electronics shall have absolutely no liability arising out of any vulnerability or security breach, including but not limited to any unauthorized access to or use of a Renesas Electronics product or a system that uses a Renesas Electronics product. RENESAS ELECTRONICS DOES NOT WARRANT OR GUARANTEE THAT RENESAS ELECTRONICS PRODUCTS, OR ANY SYSTEMS CREATED USING RENESAS ELECTRONICS PRODUCTS WILL BE INVULNERABLE OR FREE FROM CORRUPTION, ATTACK, VIRUSES, INTERFERENCE, HACKING, DATA LOSS OR THEFT, OR OTHER SECURITY INTRUSION ("Vulnerability Issues"). RENESAS ELECTRONICS DISCLAIMS ANY AND ALL RESPONSIBILITY OR LIABILITY ARISING FROM OR RELATED TO ANY VULNERABILITY ISSUES. FURTHERMORE, TO THE EXTENT PERMITTED BY APPLICABLE LAW, RENESAS ELECTRONICS DISCLAIMS ANY AND ALL WARRANTIES, EXPRESS OR IMPLIED, WITH RESPECT TO THIS DOCUMENT AND ANY RELATED OR ACCOMPANYING SOFTWARE OR HARDWARE, INCLUDING BUT NOT LIMITED TO THE IMPLIED WARRANTIES OF MERCHANTABILITY, OR FITNESS FOR A PARTICULAR PURPOSE.
8. When using Renesas Electronics products, refer to the latest product information (data sheets, user's manuals, application notes, "General Notes for Handling and Using Semiconductor Devices" in the reliability handbook, etc.), and ensure that usage conditions are within the ranges specified by Renesas Electronics with respect to maximum ratings, operating power supply voltage range, heat dissipation characteristics, installation, etc. Renesas Electronics disclaims any and all liability for any malfunctions, failure or accident arising out of the use of Renesas Electronics products outside of such specified ranges.

9. Although Renesas Electronics endeavors to improve the quality and reliability of Renesas Electronics products, semiconductor products have specific characteristics, such as the occurrence of failure at a certain rate and malfunctions under certain use conditions. Unless designated as a high reliability product or a product for harsh environments in a Renesas Electronics data sheet or other Renesas Electronics document, Renesas Electronics products are not subject to radiation resistance design. You are responsible for implementing safety measures to guard against the possibility of bodily injury, injury or damage caused by fire, and/or danger to the public in the event of a failure or malfunction of Renesas Electronics products, such as safety design for hardware and software, including but not limited to redundancy, fire control and malfunction prevention, appropriate treatment for aging degradation or any other appropriate measures. Because the evaluation of microcomputer software alone is very difficult and impractical, you are responsible for evaluating the safety of the final products or systems manufactured by you.
10. Please contact a Renesas Electronics sales office for details as to environmental matters such as the environmental compatibility of each Renesas Electronics product. You are responsible for carefully and sufficiently investigating applicable laws and regulations that regulate the inclusion or use of controlled substances, including without limitation, the EU RoHS Directive, and using Renesas Electronics products in compliance with all these applicable laws and regulations. Renesas Electronics disclaims any and all liability for damages or losses occurring as a result of your noncompliance with applicable laws and regulations.
11. Renesas Electronics products and technologies shall not be used for or incorporated into any products or systems whose manufacture, use, or sale is prohibited under any applicable domestic or foreign laws or regulations. You shall comply with any applicable export control laws and regulations promulgated and administered by the governments of any countries asserting jurisdiction over the parties or transactions.
12. It is the responsibility of the buyer or distributor of Renesas Electronics products, or any other party who distributes, disposes of, or otherwise sells or transfers the product to a third party, to notify such third party in advance of the contents and conditions set forth in this document.
13. This document shall not be reprinted, reproduced or duplicated in any form, in whole or in part, without prior written consent of Renesas Electronics.
14. Please contact a Renesas Electronics sales office if you have any questions regarding the information contained in this document or Renesas Electronics products.  
(Note 1) "Renesas Electronics" as used in this document means Renesas Electronics Corporation and also includes its directly or indirectly controlled subsidiaries.  
(Note 2) "Renesas Electronics product(s)" means any product developed or manufactured by or for Renesas Electronics.

(Rev. 4.0-2 April 2020)

## Corporate Headquarters

TOYOSU FORESIA, 3-2-24 Toyosu,  
Koto-ku, Tokyo 135-0061, Japan  
[www.renesas.com](http://www.renesas.com)

## Contact Information

For further information on a product, technology, the most up-to-date version of a document, or your nearest sales office, please visit:  
[www.renesas.com/contact/](http://www.renesas.com/contact/)

## Trademarks

Renesas and the Renesas logo are trademarks of Renesas Electronics Corporation. All trademarks and registered trademarks are the property of their respective owners.