

To our customers,

Old Company Name in Catalogs and Other Documents

On April 1st, 2010, NEC Electronics Corporation merged with Renesas Technology Corporation, and Renesas Electronics Corporation took over all the business of both companies. Therefore, although the old company name remains in this document, it is a valid Renesas Electronics document. We appreciate your understanding.

Renesas Electronics website: <http://www.renesas.com>

April 1st, 2010
Renesas Electronics Corporation

Issued by: Renesas Electronics Corporation (<http://www.renesas.com>)

Send any inquiries to <http://www.renesas.com/inquiry>.

Notice

1. All information included in this document is current as of the date this document is issued. Such information, however, is subject to change without any prior notice. Before purchasing or using any Renesas Electronics products listed herein, please confirm the latest product information with a Renesas Electronics sales office. Also, please pay regular and careful attention to additional and different information to be disclosed by Renesas Electronics such as that disclosed through our website.
2. Renesas Electronics does not assume any liability for infringement of patents, copyrights, or other intellectual property rights of third parties by or arising from the use of Renesas Electronics products or technical information described in this document. No license, express, implied or otherwise, is granted hereby under any patents, copyrights or other intellectual property rights of Renesas Electronics or others.
3. You should not alter, modify, copy, or otherwise misappropriate any Renesas Electronics product, whether in whole or in part.
4. Descriptions of circuits, software and other related information in this document are provided only to illustrate the operation of semiconductor products and application examples. You are fully responsible for the incorporation of these circuits, software, and information in the design of your equipment. Renesas Electronics assumes no responsibility for any losses incurred by you or third parties arising from the use of these circuits, software, or information.
5. When exporting the products or technology described in this document, you should comply with the applicable export control laws and regulations and follow the procedures required by such laws and regulations. You should not use Renesas Electronics products or the technology described in this document for any purpose relating to military applications or use by the military, including but not limited to the development of weapons of mass destruction. Renesas Electronics products and technology may not be used for or incorporated into any products or systems whose manufacture, use, or sale is prohibited under any applicable domestic or foreign laws or regulations.
6. Renesas Electronics has used reasonable care in preparing the information included in this document, but Renesas Electronics does not warrant that such information is error free. Renesas Electronics assumes no liability whatsoever for any damages incurred by you resulting from errors in or omissions from the information included herein.
7. Renesas Electronics products are classified according to the following three quality grades: “Standard”, “High Quality”, and “Specific”. The recommended applications for each Renesas Electronics product depends on the product’s quality grade, as indicated below. You must check the quality grade of each Renesas Electronics product before using it in a particular application. You may not use any Renesas Electronics product for any application categorized as “Specific” without the prior written consent of Renesas Electronics. Further, you may not use any Renesas Electronics product for any application for which it is not intended without the prior written consent of Renesas Electronics. Renesas Electronics shall not be in any way liable for any damages or losses incurred by you or third parties arising from the use of any Renesas Electronics product for an application categorized as “Specific” or for which the product is not intended where you have failed to obtain the prior written consent of Renesas Electronics. The quality grade of each Renesas Electronics product is “Standard” unless otherwise expressly specified in a Renesas Electronics data sheets or data books, etc.
 - “Standard”: Computers; office equipment; communications equipment; test and measurement equipment; audio and visual equipment; home electronic appliances; machine tools; personal electronic equipment; and industrial robots.
 - “High Quality”: Transportation equipment (automobiles, trains, ships, etc.); traffic control systems; anti-disaster systems; anti-crime systems; safety equipment; and medical equipment not specifically designed for life support.
 - “Specific”: Aircraft; aerospace equipment; submersible repeaters; nuclear reactor control systems; medical equipment or systems for life support (e.g. artificial life support devices or systems), surgical implantations, or healthcare intervention (e.g. excision, etc.), and any other applications or purposes that pose a direct threat to human life.
8. You should use the Renesas Electronics products described in this document within the range specified by Renesas Electronics, especially with respect to the maximum rating, operating supply voltage range, movement power voltage range, heat radiation characteristics, installation and other product characteristics. Renesas Electronics shall have no liability for malfunctions or damages arising out of the use of Renesas Electronics products beyond such specified ranges.
9. Although Renesas Electronics endeavors to improve the quality and reliability of its products, semiconductor products have specific characteristics such as the occurrence of failure at a certain rate and malfunctions under certain use conditions. Further, Renesas Electronics products are not subject to radiation resistance design. Please be sure to implement safety measures to guard them against the possibility of physical injury, and injury or damage caused by fire in the event of the failure of a Renesas Electronics product, such as safety design for hardware and software including but not limited to redundancy, fire control and malfunction prevention, appropriate treatment for aging degradation or any other appropriate measures. Because the evaluation of microcomputer software alone is very difficult, please evaluate the safety of the final products or system manufactured by you.
10. Please contact a Renesas Electronics sales office for details as to environmental matters such as the environmental compatibility of each Renesas Electronics product. Please use Renesas Electronics products in compliance with all applicable laws and regulations that regulate the inclusion or use of controlled substances, including without limitation, the EU RoHS Directive. Renesas Electronics assumes no liability for damages or losses occurring as a result of your noncompliance with applicable laws and regulations.
11. This document may not be reproduced or duplicated, in any form, in whole or in part, without prior written consent of Renesas Electronics.
12. Please contact a Renesas Electronics sales office if you have any questions regarding the information contained in this document or Renesas Electronics products, or if you have any other inquiries.

(Note 1) “Renesas Electronics” as used in this document means Renesas Electronics Corporation and also includes its majority-owned subsidiaries.

(Note 2) “Renesas Electronics product(s)” means any product developed or manufactured by or for Renesas Electronics.

USER'S MANUAL

Phase-out/Discontinued

μ PD75518
4 BIT SINGLE-CHIP MICROCOMPUTER

μ PD75517
 μ PD75518
 μ PD75P518

Cautions on CMOS Devices

① **Countermeasures against static electricity for all MOSs**

Caution When handling MOS devices, take care so that they are not electrostatically charged.

Strong static electricity may cause dielectric breakdown in gates. When transporting or storing MOS devices, use conductive trays, magazine cases, shock absorbers, or metal cases that NEC uses for packaging and shipping. Be sure to ground MOS devices during assembling. Do not allow MOS devices to stand on plastic plates or do not touch pins.

Also handle boards on which MOS devices are mounted in the same way.

② **CMOS-specific handling of unused input pins**

Caution Hold CMOS devices at a fixed input level.

Unlike bipolar or NMOS devices, if a CMOS device is operated with no input, an intermediate-level input may be caused by noise. This allows current to flow in the CMOS device, resulting in a malfunction. Use a pull-up or pull-down resistor to hold a fixed input level. Since unused pins may function as output pins at unexpected times, each unused pin should be separately connected to the V_{DD} or GND pin through a resistor.

If handling of unused pins is documented, follow the instructions in the document.

③ **Statuses of all MOS devices at initialization**

Caution The initial status of a MOS device is unpredictable when power is turned on.

Since characteristics of a MOS device are determined by the amount of ions implanted in molecules, the initial status cannot be determined in the manufacture process. NEC has no responsibility for the output statuses of pins, input and output settings, and the contents of registers at power on. However, NEC assures operation after reset and items for mode setting if they are defined.

When you turn on a device having a reset function, be sure to reset the device first.

QTOP is a trademark of NEC Corporation.

MS-DOS is a trademark of Microsoft Corporation.

PC DOS and PC/AT are trademarks of IBM Corporation.

The information in this document is subject to change without notice.

No part of this document may be copied or reproduced in any form or by any means without the prior written consent of NEC Corporation. NEC Corporation assumes no responsibility for any errors which may appear in this document.

NEC Corporation does not assume any liability for infringement of patents, copyrights or other intellectual property rights of third parties by or arising from use of a device described herein or any other liability arising from use of such device. No license, either express, implied or otherwise, is granted under any patents, copyrights or other intellectual property rights of NEC Corporation or others.

The devices listed in this document are not suitable for use in aerospace equipment, submarine cables, nuclear reactor control systems and life support systems. If customers intend to use NEC devices for above applications or they intend to use "Standard" quality grade NEC devices for applications not intended by NEC, please contact our sales people in advance.

Application examples recommended by NEC Corporation

Standard: Computer, Office equipment, Communication equipment, Test and Measurement equipment, Machine tools, Industrial robots, Audio and Visual equipment, Other consumer products, etc.

Special: Automotive and Transportation equipment, Traffic control systems, Antidisaster systems, Anticrime systems, etc.

Major Changes

Page	Description
Preface	Documents related to the development tools and other documents have been added.
Preface P.1-1 and P.1-8	A caution concerning the reliability of the μ PD75P518K has been added.
P.1-3	Descriptions of the stack bank selection register (SBS) and stack operation have been added to Section 1.1 .
P.1-5	Section 1.3 has been added.
P.2-9 and P.2-10	Descriptions of the release of the STOP and HALT modes have been added to Sections 2.2.10 and 2.2.11 .
P.2-12	The descriptions in Section 2.2.20 have been modified.
P.2-17	The recommended connections for IC and V_{PP} , listed in Table 2-3 , have been modified.
P.5-5	Figures 5-3 and 5-4 have been modified.
P.5-33	A caution concerning the machine cycle has been added to Table 5-5 .
P.5-69	Figure 5-38 has been modified.
P.5-71	The descriptions and figure in (4) of Section 5.6.4 have been modified. A caution has been added to (4) of Section 5.6.4 .
P.6-6	The descriptions in (1) of Section 6.3 have been modified.
P.6-20	The sample programs given in Section 6.6 have been replaced.
P.7-6	Descriptions relating to the use of a crystal have been added to Section 7.2 .
P.7-7	A caution has been added to Table 7-2 .
P.7-9	The timing chart in (1) of Section 7.4 has been modified.
P.7-12	A caution concerning the switching system clock has been added to (2) of Section 7.4 .
P.8-3	Table 8-1 has been modified.
P.9-7	Section 9.5 has been added.
P.A-2	The version of MS-DOS has been upgraded to 5.00A in Appendix A . Therefore, a caution concerning the upgrade has been added.
P.C-1	Appendix C has been added.

Major changes in this revision are indicated by stars (*) in the margins.

Phase-out/Discontinued

[MEMO]

Preface

Readers:

This manual is intended for engineers who want to learn the capabilities of the μ PD75517, μ PD75518, and μ PD75P518 to develop application systems based on them.

Purpose:

The purpose of this manual is to help users understand the hardware capabilities of the μ PD75517, μ PD75518, and μ PD75P518.

Guidance:

Readers of this manual should have general knowledge of the electronics, logical circuit, and microcomputer fields.

To understand the overall functions of the μ PD75517, μ PD75518, and μ PD75P518:

-> Read through all chapters sequentially.

To check the function of an instruction in detail when the reader knows its mnemonics:

-> See the instruction index in **Appendix D**.

To refresh his or her memory of the function of an instruction when the reader does not know its mnemonic but almost understand the function:

-> See **Section 10.2** to find the mnemonic of the instruction, then see **Section 10.4** to confirm its function.

To check the electrical characteristics of the μ PD75518:

-> Refer to the separate data sheet.

Unless there is a difference in function between the μ PD75517 and μ PD75518 or μ PD75P518, only the μ PD75518 is described in this manual. The user of the μ PD75517 or μ PD75P518 should read μ PD75518 as μ PD75517 or μ PD75P518.

In descriptions common to the one-time PROM product and EPROM product, the term PROM is used to represent both products.

The μ PD75P518K is not intended for use in mass-produced products; it does not offer a sufficiently high level of reliability for such applications. The use of the μ PD75P518K should be restricted to functional evaluation in experimental or trial manufacture.

*

Notation:

Data bit significance : Higher-order bits on the left side
Lower-order bits on the right side

Active low : $\overline{\text{xxx}}$ (Pin and signal names are overscored.)

Memory map address: Low-order address on the upper side
High-order address on the lower side

(Note) : Explanation of an indicated part of text

Caution : Information requesting the user's special attention

Remark : Supplementary information

Numeric value : Binary: xxxx or xxxxB
Decimal: xxxx
Hexadecimal: xxxxH

Related Documents**Documents related to the device**

Document		Product	μ PD75517	μ PD75518	μ PD75P518
Data Sheet			IC-2672	IC-2706	IC-2839
User's Manual			This manual		
Application Note	Basic		IEM-1259		
	A/D Converter		IEA-1236		
75X Series Selection Guide			IF-1027		

Documents related to development tools

*

Document name			Document No.
Hardware	IE-75000-R/IE-75001-R User's Manual		EEU-1416
	IE-75000-R-EM User's Manual		EEU-1294
	EP-75516GF-R		EEU-1315
	PG-1500 User's Manual		EEU-1335
Software	RA75X Assembler Package User's Manual	Operation	EEU-1346
		Language	EEU-1343
	PG-1500 Controller User's Manual		EEU-1291

Other documents

*

Document name	Document No.
Package Manual	IEI-1231
SMD Surface Mount Technology Manual	IEI-1207
Quality Grades on NEC Semiconductor Devices	IEI-1209
Guide to Quality Assurance for Semiconductor Devices	IEI-1202

Caution **The above documents may be revised without notice. Use the latest versions when designing an application system.**

Phase-out/Discontinued

[MEMO]

Summary of Contents

Chapter 1	General	1-1
Chapter 2	Pin Functions	2-1
Chapter 3	Data Memory Operations and Memory Map	3-1
Chapter 4	Internal CPU Functions	4-1
Chapter 5	Peripheral Hardware Functions	5-1
Chapter 6	Interrupt Function	6-1
Chapter 7	Standby Function	7-1
Chapter 8	Reset Function	8-1
Chapter 9	Writing to and Verifying Program Memory (PROM)	9-1
Chapter 10	Instruction Set	10-1
Appendix A	Development Tools	A-1
Appendix B	Mask ROM Ordering Procedure	B-1
Appendix C	Revision History	C-1
Appendix D	Instruction Index	D-1
Appendix E	Hardware Index	E-1

[MEMO]

Contents

Chapter 1	General	1-1	
1.1	Function of the μ PD75518 Sub-Series Products.....	1-3	
1.2	Ordering Information	1-4	
1.3	Differences between the μ PD75P518, μ PD75517, and μ PD75518	1-5	*
1.4	Block Diagram	1-7	
1.5	Pin Configuration	1-8	
Chapter 2	Pin Functions	2-1	
2.1	Pin Functions	2-1	
2.2	Pin Functions	2-6	
2.2.1	P00-P03 (PORT0), P10-P13 (PORT1), P80-P83 (PORT8), P150-P153 (PORT15)	2-6	
2.2.2	P20-P23 (PORT2), P30-P33 (PORT3), P60-P63 (PORT6), P70-P73 (PORT7), P90-P93 (PORT9), P100-P103 (PORT10), P110-P113 (PORT11)	2-7	
2.2.3	P40-P43 (PORT4), P50-P53 (PORT5), P120-P123 (PORT12), P130-P133 (PORT13), P140-P143 (PORT14)	2-8	
2.2.4	TI0	2-8	
2.2.5	PTO0	2-8	
2.2.6	PCL	2-8	
2.2.7	BUZ	2-8	
2.2.8	SCK0, SO0/SB0, SI0/SB1, SCK1, SO1, SI1	2-9	
2.2.9	INT4	2-9	
2.2.10	INT0, INT1	2-9	
2.2.11	INT2	2-10	
2.2.12	KR0-KR3, KR4-KR7	2-10	
2.2.13	PPO	2-10	
2.2.14	AN0-AN3, AN4-AN7	2-10	
2.2.15	AV _{REF}	2-10	
2.2.16	AV _{SS}	2-10	
2.2.17	X1, X2	2-11	
2.2.18	XT1, XT2	2-11	
2.2.19	RESET	2-11	
2.2.20	IC	2-12	
2.2.21	MD0-MD3 (for μ PD75P518 only)	2-12	
2.2.22	V _{PP} (for μ PD75P518 only)	2-12	
2.2.23	V _{DD}	2-12	

2.2.24	V_{SS}	2-12
2.3	Pin Input/Output Circuits.....	2-13
2.4	Connection of Unused Pins.....	2-16
2.5	Selection of a Mask Option.....	2-17
Chapter 3	Data Memory Operations and Memory Map.....	3-1
3.1	Data Memory Bank Structure and Addressing Modes.....	3-2
3.1.1	Data Memory Bank Structure.....	3-2
3.1.2	Data Memory Addressing Modes.....	3-4
3.2	General Register Bank Configuration.....	3-17
3.3	Memory-mapped I/O.....	3-22
Chapter 4	Internal CPU Functions.....	4-1
4.1	Program Counter (PC).....	4-1
4.2	Program Memory (ROM).....	4-2
4.3	Data Memory (RAM).....	4-5
4.3.1	Data Memory Configuration.....	4-5
4.3.2	Specification of a Data Memory Bank.....	4-7
4.4	General Register.....	4-8
4.5	Accumulator.....	4-10
4.6	Stack Pointer (SP) and Stack Bank Select Register (SBS).....	4-11
4.7	Program Status Word (PSW).....	4-14
4.8	Bank Select Register (BS).....	4-18
Chapter 5	Peripheral Hardware Functions.....	5-1
5.1	Digital I/O Ports.....	5-1
5.1.1	Types, Features, and Configurations of Digital I/O Ports.....	5-2
5.1.2	I/O Mode Setting.....	5-9
5.1.3	Digital I/O Port Manipulation Instructions.....	5-12
5.1.4	Digital I/O Port Operation.....	5-15
5.1.5	Specification of Internal Pull-Up/Pull-Down Resistors.....	5-17
5.1.6	I/O Timing of Digital I/O Ports.....	5-20
5.2	Clock Generator.....	5-21
5.2.1	Clock Generator Configuration.....	5-22
5.2.2	Functions and Operations of the Clock Generator.....	5-23
5.2.3	System Clock and CPU Clock Setting.....	5-32
5.2.4	Clock Output Circuit.....	5-35
5.3	Basic Interval Timer.....	5-38
5.3.1	Configuration of the Basic Interval Timer.....	5-38
5.3.2	Basic Interval Timer Mode Register (BTM).....	5-39
5.3.3	Operation of the Basic Interval Timer.....	5-41
5.3.4	Application Examples of the Basic Interval Timer.....	5-42

5.4	Clock Timer	5-44
5.4.1	Configuration of the Clock Timer	5-44
5.4.2	Watch Mode Register	5-45
5.5	Timer/Event Counter	5-46
5.5.1	Configuration of the Timer/Event Counter	5-46
5.5.2	Basic Configuration and Operation of the Timer/Event Counter	5-48
5.5.3	Timer/Event Counter Mode Register (TM0)	5-49
5.5.4	Timer/Event Counter Output Enable Flag (TOE0)	5-51
5.5.5	Operation Mode of the Timer/Event Counter	5-51
5.5.6	Time Setting in the Timer/Event Counter	5-53
5.5.7	Notes on Timer/Event Counter Applications	5-55
5.5.8	Applications of the Timer/Event Counter	5-59
5.6	Timer/Pulse Generator	5-60
5.6.1	Functions of the Timer/Pulse Generator	5-60
5.6.2	Timer/Pulse Generator Mode Register (TPGM)	5-61
5.6.3	Configuration and Operation of the Timer/Pulse Generator ...	5-62
5.6.4	Application of the Timer/Pulse Generator	5-68
5.7	Serial Interface (Channel 0)	5-73
5.7.1	Serial Interface (Channel 0) Functions	5-73
	(1) Operation halt mode	5-73
	(2) Three-wire serial I/O mode	5-73
	(3) Two-wire serial I/O mode	5-74
	(4) Serial bus interface (SBI) mode	5-74
5.7.2	Configuration of Serial Interface (Channel 0)	5-74
	(1) Serial operation mode register 0 (CSIM0)	5-76
	(2) Serial bus interface control register (SBIC)	5-76
	(3) Shift register 0 (SIO0)	5-76
	(4) SO0 latch	5-76
	(5) Serial clock selector	5-76
	(6) Serial clock counter	5-76
	(7) Slave address register (SVA) and address comparator ...	5-76
	(8) INTCSI0 control circuit	5-77
	(9) Serial clock control circuit	5-77
	(10) Busy/acknowledge output circuit and bus release/ command/acknowledge detection circuit	5-77
	(11) P01 output latch	5-77
5.7.3	Register Functions	5-78
	(1) Serial operation mode register 0 (CSIM0)	5-78
	(2) Serial bus interface control register (SBIC)	5-82
	(3) Shift register 0 (SIO0)	5-85
	(4) Slave address register (SVA)	5-87
5.7.4	Operation Halt Mode	5-88
5.7.5	Three-Wire Serial I/O Mode Operations	5-90
	(1) Register setting	5-90
	(2) Communication operation	5-93
	(3) Serial clock selection	5-94
	(4) Signals	5-94
	(5) Switching between MSB and LSB as the first transfer bit	5-95
	(6) Transfer start	5-96
	(7) Application of the three-wire serial I/O mode	5-97
5.7.6	Two-Wire Serial I/O Mode	5-100
	(1) Register setting	5-100

	(2) Communication operation	5-103
	(3) Serial clock selection	5-104
	(4) Signals	5-104
	(5) Transfer start	5-105
	(6) Error detection	5-105
	(7) Application of two-wire serial I/O mode	5-106
5.7.7	SBI Mode Operation	5-107
	(1) SBI functions	5-109
	(2) SBI definition	5-110
	(3) Register setting	5-116
	(4) Serial clock selection	5-120
	(5) Signals	5-121
	(6) Pin configuration	5-127
	(7) Address match detection method	5-128
	(8) Error detection	5-128
	(9) Communication operation	5-129
	(10) Transfer start	5-134
	(11) Notes on the SBI mode	5-135
	(12) SBI mode	5-136
5.7.8	Manipulation of SCK0 Pin Output	5-143
5.8	Serial Interface (Channel 1)	5-145
5.8.1	Serial Interface (Channel 1) Functions	5-145
	(1) Operation halt mode	5-145
	(2) Three-wire serial I/O mode	5-145
5.8.2	Serial Interface (Channel 1) Configuration	5-145
5.8.3	Register Functions	5-147
	(1) Serial operation mode register 1 (CSIM1)	5-147
	(2) Shift register 1 (SIO1)	5-148
5.8.4	Operation Halt Mode	5-148
5.8.5	Three-Wire Serial I/O Mode Operations	5-149
5.8.6	Application of the Serial Interface (Channel 1)	5-151
5.9	A/D Converter	5-152
5.9.1	Configuration of the A/D Converter	5-152
5.9.2	A/D Converter Operation	5-156
5.9.3	Notes on the Standby Mode	5-159
5.9.4	Other Notes on Use	5-160
5.9.5	Application of A/D Converter	5-161
5.10	Bit Sequential Buffer	5-162
5.10.1	Applications of the Bit Sequential Buffer	5-163
Chapter 6	Interrupt Function	6-1
6.1	Configuration of the Interrupt Control Circuit	6-1
6.2	Types of Interrupt Sources and Vector Tables	6-3
6.3	Various Devices of the Interrupt Control Circuit	6-5
6.4	Interrupt Sequence	6-16
6.5	Multiple Interrupt Processing Control	6-17
6.6	Processing of Interrupts Sharing a Vector Address	6-19
6.7	Machine Cycles for Starting Interrupt Processing	6-21
6.8	Effective Use of Interrupts	6-23

6.9	Interrupt Applications.....	6-23	
Chapter 7	Standby Function	7-1	
7.1	Setting of Standby Modes and Operation Status	7-3	
7.2	Release of the Standby Modes	7-5	
7.3	Operation after a Standby Mode Is Released.....	7-8	
7.4	Applications of the Standby Modes	7-8	
Chapter 8	Reset Function	8-1	
Chapter 9	Writing to and Verifying Program Memory (PROM)	9-1	
9.1	Operating Modes when Writing to and Verifying the Program Memory	9-3	
9.2	Writing to the Program Memory	9-4	
9.3	Reading the Program Memory	9-6	
9.4	Erasing the Program Memory (for the μ PD75P518K Only).....	9-7	
9.5	Screening One-Time PROM Products	9-7	*
Chapter 10	Instruction Set.....	10-1	
10.1	Unique Instructions	10-2	
10.1.1	GETI Instruction	10-2	
10.1.2	Bit Manipulation Instructions	10-4	
10.1.3	String Effect Instructions.....	10-5	
10.1.4	Number System Conversion Instructions	10-6	
10.1.5	Skip Instructions and the Number of Machine Cycles Required for a Skip	10-7	
10.2	Instruction Set and Operation	10-8	
10.3	Instruction Codes of Each Instruction	10-18	
10.4	Functions and Applications of the Instructions	10-24	
10.4.1	Transfer Instructions	10-24	
10.4.2	Table Reference Instructions	10-29	
10.4.3	Bit Transfer Instructions.....	10-33	
10.4.4	Arithmetic/Logical Instructions	10-34	
10.4.5	Accumulator Manipulation Instructions.....	10-39	
10.4.6	Increment/Decrement Instructions	10-39	
10.4.7	Compare Instructions	10-40	
10.4.8	Carry Flag Manipulation Instructions.....	10-41	
10.4.9	Memory Bit Manipulation Instructions	10-42	
10.4.10	Branch Instructions.....	10-44	
10.4.11	Subroutine Stack Control Instructions.....	10-48	
10.4.12	Interrupt Control Instructions.....	10-51	
10.4.13	I/O Instructions	10-51	
10.4.14	CPU Control Instructions	10-53	
10.4.15	Special Instructions	10-53	

- Appendix A Development ToolsA-1
- Appendix B Masked ROM Ordering ProcedureB-1
- * Appendix C Revision HistoryC-1
- Appendix D Instruction IndexD-1
 - D.1 Instruction Index (By Function).....D-1
 - D.2 Instruction Index (Alphabetical Order).....D-4
- Appendix E Hardware IndexE-1
 - E.1 Hardware Index (Alphabetical Order with Respect to the Hardware Name)E-1
 - E.2 Hardware Index (Alphabetical Order with Respect to the Hardware Symbol).....E-3

List of Figures

(1/4)

Figure 2-1.	Pin Input/Output Circuits	2-13
Figure 3-1.	Use of MBE = 0 Mode and MBE = 1 Mode	3-3
Figure 3-2.	Data Memory Organization and Addressing Range of Each Addressing Mode	3-4
Figure 3-3.	Updating Static RAM Addresses	3-11
Figure 3-4.	Example of Register Bank Selection	3-18
Figure 3-5.	General Register Configuration (4-bit Processing)	3-20
Figure 3-6.	General Register Configuration (8-bit Processing)	3-21
Figure 3-7.	μ PD75518 I/O Map	3-24
Figure 4-1.	Program Counter Format	4-1
Figure 4-2.	Program Memory Map (μ PD75517)	4-3
Figure 4-3.	Program Memory Map (μ PD75518 and μ PD75P518)	4-4
Figure 4-4.	Data Memory Map	4-5
Figure 4-5.	General Register Format	4-9
Figure 4-6.	Register Pair Format	4-9
Figure 4-7.	Accumulator	4-10
Figure 4-8.	Format of Stack Pointer and Stack Bank Select Register	4-12
Figure 4-9.	Data Saved to Stack Memory	4-13
Figure 4-10.	Data Restored from Stack Memory	4-13
Figure 4-11.	Program Status Word Format	4-14
Figure 4-12.	Bank Select Register Format	4-18
Figure 5-1.	Data Memory Address Assigned to Digital I/O Ports	5-1
Figure 5-2.	Configurations of Ports 0, 1, and 8	5-4
Figure 5-3.	Configurations of Ports 3n and 6n (n = 0 to 3)	5-5
Figure 5-4.	Configurations of Ports 2 and 7	5-5
Figure 5-5.	Configurations of Ports 4, 5, 12, 13, and 14	5-6
Figure 5-6.	Configuration of Port 9	5-7
Figure 5-7.	Configurations of Ports 10 and 11	5-8
Figure 5-8.	Configuration of Port 15	5-8
Figure 5-9.	Formats of Port Mode Registers	5-10
Figure 5-10.	Format of the Pull-up Resistor Register	5-18

Figure 5-11.	ON Timing of Pull-up Resistors by Software	5-18
Figure 5-12.	I/O Timing of Digital I/O Ports	5-20
Figure 5-13.	Block Diagram of the Clock Generator	5-22
Figure 5-14.	Format of the Processor Clock Control Register	5-25
Figure 5-15.	Format of the System Clock Control Register	5-26
Figure 5-16.	External Circuit for the Main System Clock Oscillator	5-27
Figure 5-17.	External Circuit for the Subsystem Clock Oscillator.....	5-28
Figure 5-18.	Examples of Oscillator Connections which should be Avoided	5-29
Figure 5-19.	Changing the System Clock and CPU Clock	5-34
Figure 5-20.	Configuration of the Clock Output Circuit.....	5-35
Figure 5-21.	Format of the Clock Output Mode Register	5-36
Figure 5-22.	Application to Remote Control Output	5-37
Figure 5-23.	Configuration of the Basic Interval Timer	5-38
Figure 5-24.	Format of the Basic Interval Timer Mode Register	5-40
Figure 5-25.	Block Diagram of the Clock Timer	5-44
Figure 5-26.	Format of the Watch Mode Register	5-45
Figure 5-27.	Block Diagram of the Timer/Event Counter.....	5-47
Figure 5-28.	Timing of Count Operation	5-48
Figure 5-29.	Format of the Timer/Event Counter Mode Register	5-50
Figure 5-30.	Format of the Timer/Event Counter Output Enable Flag	5-51
Figure 5-31.	Operation in the Count Operation Mode	5-52
Figure 5-32.	Error at the Start of the Timer	5-55
Figure 5-33.	Format of Timer/Pulse Generator Mode Register	5-61
Figure 5-34.	Block Diagram of the Timer/Pulse Generator (Timer Mode).....	5-62
Figure 5-35.	Timer Mode Operation Timing	5-63
Figure 5-36.	Block Diagram of the Timer/Pulse Generator (PWM Pulse Generation Mode).....	5-67
Figure 5-37.	Sample Configuration of D/A Conversion Using μ PD75518.....	5-67
Figure 5-38.	Sample Circuit Applicable to TV Tuners.....	5-69
Figure 5-39.	Example of the SBI System Configuration	5-74
Figure 5-40.	Block Diagram of the Serial Interface (Channel 0).....	5-75
Figure 5-41.	Format of Serial Operation Mode Register 0 (CSIM0).....	5-78
Figure 5-42.	Format of Serial Bus Interface Control Register (SBIC).....	5-82
Figure 5-43.	Peripheral Hardware of Shift Register 0.....	5-86
Figure 5-44.	Example of Three-Wire Serial I/O System Configuration	5-90
Figure 5-45.	Timing of Three-Wire Serial I/O Mode	5-93
Figure 5-46.	Operations of RELT and CMDT.....	5-94
Figure 5-47.	Transfer Bit Switching Circuit	5-95
Figure 5-48.	Example of Two-Wire Serial I/O System Configuration	5-100
Figure 5-49.	Timing of Two-Wire Serial I/O Mode	5-103
Figure 5-50.	Operations of RELT and CMDT	5-104
Figure 5-51.	Example of SBI System Configuration.....	5-108
Figure 5-52.	Timing of SBI Transfer	5-110
Figure 5-53.	Bus Release Signal	5-111

Figure 5-54.	Command Signal	5-111
Figure 5-55.	Address	5-112
Figure 5-56.	Slave Selection Using an Address	5-112
Figure 5-57.	Command	5-113
Figure 5-58.	Data	5-113
Figure 5-59.	Acknowledge Signal	5-114
Figure 5-60.	Busy and Ready Signals	5-115
Figure 5-61.	Operations of RELT, CMDT, RELD, and CMDD (Master)	5-121
Figure 5-62.	Operations of RELT, CMDT, RELD, and CMDD (Slave)	5-121
Figure 5-63.	Operation of ACKT	5-122
Figure 5-64.	Operation of ACKE	5-123
Figure 5-65.	Operation of ACKD	5-124
Figure 5-66.	Operation of BSYE	5-124
Figure 5-67.	Pin Configuration	5-127
Figure 5-68.	Address Transfer Operation from Master Device to Slave Device (WUP = 1)	5-130
Figure 5-69.	Command Transfer Operation from Master Device to Slave Device	5-131
Figure 5-70.	Data Transfer Operation from Master Device to Slave Device	5-132
Figure 5-71.	Data Transfer Operation from Slave Device to Master Device	5-133
Figure 5-72.	Example of Serial Bus Configuration	5-136
Figure 5-73.	Transfer Format of the READ Command	5-138
Figure 5-74.	Transfer Format of the WRITE and END Commands	5-139
Figure 5-75.	Transfer Format of the STOP Command	5-139
Figure 5-76.	Transfer Format of the STATUS Command	5-140
Figure 5-77.	Status Format of the STATUS Command	5-140
Figure 5-78.	Transfer Format of the RESET Command	5-141
Figure 5-79.	Transfer Format of the CHGMST Command	5-141
Figure 5-80.	Master and Slave Operation in Case of Error	5-142
Figure 5-81.	SCK0/P01 Pin Circuit Configuration	5-143
Figure 5-82.	Block Diagram of the Serial Interface (Channel 1)	5-146
Figure 5-83.	Format of Serial Operation Mode Register 1 (CSIM1)	5-147
Figure 5-84.	Timing of the Three-wire Serial I/O Mode	5-149
Figure 5-85.	Block Diagram of the A/D Converter	5-152
Figure 5-86.	Format of the A/D Conversion Mode Register	5-154
Figure 5-87.	Timing Chart of A/D Conversion	5-157
Figure 5-88.	Relationship (Ideal) between Analog Input Voltages and Results of A/D Conversion	5-158
Figure 5-89.	Reducing Power Consumption in the Standby Mode	5-159
Figure 5-90.	Analog Input Pin Connection	5-160
Figure 5-91.	Format of the Bit Sequential Buffer	5-162
Figure 5-92.	Serial Transfer Format (I)	5-164
Figure 5-93.	Serial Transfer Format (II)	5-165
Figure 5-94.	Bus Configuration Example	5-165

Figure 6-1.	Block Diagram of Interrupt Control Circuit	6-2
Figure 6-2.	Interrupt Vector Table	6-4
Figure 6-3.	Configurations of the INT0, INT1, and INT4 Circuits	6-8
Figure 6-4.	I/O Timing of a Noise Eliminator	6-9
Figure 6-5.	Format of Edge Detection Mode Registers	6-10
Figure 6-6.	Configuration of the INT2 and KR0 to KR7 Circuits	6-12
Figure 6-7.	Interrupt Priority Specification Register	6-14
Figure 6-8.	Interrupt Processing Sequence	6-16
Figure 6-9.	Multiple Interrupt Processing by a High-order Interrupt.....	6-17
Figure 6-10.	Multiple Interrupt Processing by Changing the Interrupt Status Flags.....	6-18
Figure 7-1.	Standby Mode Release Operation	7-5
Figure 8-1.	Reset Operation by a \overline{RESET} signal.....	8-1

List of Tables

(1/2)

Table 1-1.	Differences between the μ PD75P518, μ PD75517, and μ PD75518	1-5	*
Table 2-1.	Digital I/O Port Pins	2-1	
Table 2-2.	Non-port Pin Functions	2-4	
Table 2-3.	Recommended Connection of Unused Pins	2-16	
Table 2-4.	Selection of Pull-up and Pull-down Resistors	2-17	
Table 2-5.	Selection of Feedback Resistors	2-17	
Table 3-1.	Addressing Modes	3-5	
Table 3-2.	Register Bank to Be Selected with the RBE and RBS	3-17	
Table 3-3.	Recommended Use of Register Banks with Normal Routines and Interrupt Routines	3-17	
Table 3-4.	Addressing Modes Applicable to Peripheral Hardware Operation	3-22	
Table 4-1.	Stack Area to Be Selected by the Stack Bank Select Register	4-11	
Table 4-2.	PSW Flags Saved/Restored in Stack Operation	4-14	
Table 4-3.	Carry Flag Manipulation Instructions	4-15	
Table 4-4.	Information Indicated by the Interrupt Status Flag	4-16	
Table 4-5.	Register Bank to Be Selected with the RBE and RBS	4-19	
Table 5-1.	Types and Features of Digital I/O Ports	5-2	
Table 5-2.	I/O Pin Manipulation Instructions	5-14	
Table 5-3.	Operations by I/O Port Manipulation Instructions	5-16	
Table 5-4.	Specification of Internal Pull-Up/Pull-Down Resistors	5-17	
Table 5-5.	Maximum Time Required to Change the System Clock and CPU Clock	5-32	
Table 5-6.	Resolution and Maximum Set Time	5-54	
Table 5-7.	Modulo Register Settings	5-64	
Table 5-8.	Basic and Secondary Periods	5-65	
Table 5-9.	Generation of Notes Using the Timer/Pulse Generator	5-70	
Table 5-10.	Differences between Channel 0 and Channel 1	5-73	
Table 5-11.	Serial Clock Selection and Application (In the Three-Wire Serial I/O Mode)	5-94	
Table 5-12.	Serial Clock Selection and Application (In the Two-Wire Serial I/O Mode)	5-104	
Table 5-13.	Serial Clock Selection and Application (In the SBI Mode)	5-120	
Table 5-14.	Various Signals Used in the SBI Mode	5-125	

Table 5-15.	Serial Clock Selection and Application	5-150
Table 5-16.	Setting of SCC and PCC.....	5-157
Table 6-1.	Interrupt Sources.....	6-3
Table 6-2.	Set Signals for Interrupt Request Flags	6-6
Table 6-3.	Interrupt Processing Statuses of IST0 and IST1	6-15
Table 6-4.	Determination of an Interrupt Source.....	6-19
Table 7-1.	Operation Statuses in the Standby Mode.....	7-3
Table 7-2.	Selection of a Wait Time with BTM.....	7-7
Table 8-1.	Statuses of the Hardware after a Reset	8-2
Table 9-1.	Pin Functions	9-1
Table 9-2.	Operating Modes	9-3

Chapter 1

General

The μ PD75517, μ PD75518, and μ PD75P518 are 4-bit single-chip microcomputers. Their features include high-speed operations, a large number of I/O lines, and a variety of capabilities based on the 75X series architecture.

The μ PD75517 and μ PD75518 outperform their predecessor μ PD75516 by increasing the ROM and RAM capacities of the μ PD75516 and speeding up the instruction execution.

The μ PD75P518 uses one-time PROM or EPROM, instead of built-in mask ROM which is used in the μ PD75518, for increased ROM capacity. The one-time PROM version allows the user to write programs once. It can be used for small quantities of multiple products. It is also useful to shorten product development time. The EPROM version allows the user to write, erase, and rewrite programs. It is best suited for system evaluation.

The μ PD75517, μ PD75518, and μ PD75P518 have the following features.

The μ PD75P518K is not intended for use in mass-produced products; it does not offer a sufficiently high level of reliability for such applications. The use of the μ PD75P518K should be restricted to functional evaluation in experimental or trial manufacture. *

- Function for specifying the instruction execution time (useful for high-speed operation and power saving)
- Built-in A/D converter operable on low voltage
 - Eight channels with 8-bit resolution (Successive approximation system)
 - $V_{DD} = 2.7$ to 6.0 V
- Sixty-four I/O lines
- Two built-in 8-bit serial interfaces
 - Built-in NEC serial bus interface (SBI)
- The μ PD75P518 can operate on the same supply voltage as the μ PD75517 which uses mask ROM.
 - $V_{DD} = 2.7$ to 6.0 V

The μ PD75517, μ PD75518, and μ PD75P518 provide features suitable for control, and therefore can be used for various applications as listed below:

- VCR (system control)
- Audio equipment (such as CD players)
- Push-button telephone
- Radio equipment
- Data terminal
- PPC
- Air conditioner

1.1 Function of the μ PD75518 Sub-Series Products

Item		Product	μ PD75517	μ PD75518	μ PD75P518	μ PD75516	μ PD75P516
ROM (in bytes)			24448	32640	32640 (PROM)	16256	16256 (PROM)
RAM (x 4 bits)			1024			512	
General registers			(4 bits x 8 or 8 bits x 4) x 4 banks				
Instruction	Main system clock		0.67 μ s, 1.33 μ s, 2.67 μ s, or 10.7 μ s (when operating at 6.0 MHz) 0.95 μ s, 1.91 μ s, 3.82 μ s, or 15.3 μ s (when operating at 4.19 MHz)			0.95 μ s, 1.91 μ s, or 15.3 μ s (when operating at 4.19 MHz)	
	Subsystem clock		122 μ s (When operating at 32.768 kHz)				
I/O lines ^(Note 1)	Total		64				
	Number of CMOS input lines		16 (Shared with INT, SIO, PPO, and analog input. Seven lines can be pulled up by software.)				
	Number of CMOS I/O lines		28 (Four lines for LED driving) • 16 lines can be pulled up by software. • Four lines can be pulled down by mask option.				
	Number of N-ch open-drain I/O lines		20 (Eight lines for LED driving. Withstand voltage is 10 V. 20 lines can be pulled up by mask option.)			20 (Eight lines for LED driving. Withstand voltage is 9 V. 20 lines can be pulled up by mask option.)	
A/D converter			• 8 channels with 8-bit resolution (Successive approximation system)				
	Operating voltage		$V_{DD} = 2.7$ to 6.0 V			$V_{DD} = 3.5$ to 6.0 V	
Timer/counter			4 channels [<ul style="list-style-type: none"> • Timer/event counter • Basic interval timer • Timer/pulse generator (14-bit PWM output enabled) • Clock timer 				
Serial interface			2 channels [<ul style="list-style-type: none"> • NEC standard serial bus interface (SBI)/three-wire SIO: One channel • General synchronous serial interface (three-wire SIO): One channel 				
Stack bank selection register (SBS)			Provided			Not provided	
Stack operation			3-byte stack			2-byte stack	
Vectored interrupt			External: 3, internal: 4				
Test input			External: 1, internal: 1 • Clock test flag provided • Parallel edge detection flag for key scan input provided				
Instruction set			The following instructions are added to the 75X high-end model: • MOV _T XA, @BCDE • BR !BCDE • MOV _T XA, @BCXA • BR !BCXA • BRA !addr1 • CALLA !addr1			75X high-end	
Operating power voltage			$V_{DD} = 2.7$ to 6.0 V				$V_{DD} = 4.75$ to 5.5 V
Package			• 80-pin plastic QFP (14 x 20 mm) • 80-pin ceramic WQFN ^(Note 2)				

(Note 1) No mask option is provided for the μ PD75P516 or μ PD75P518.

(Note 2) For the μ PD75P516 and μ PD75P518 only

*

*

1.2 Ordering Information

(1) Ordering information

Part number	Package	On-chip ROM
μPD75517GF-xxx-3B9	80-pin plastic QFP (14 x 20 mm)	Mask ROM
μPD75518GF-xxx-3B9	80-pin plastic QFP (14 x 20 mm)	Mask ROM
μPD75P518GF-3B9	80-pin plastic QFP (14 x 20 mm)	One-time PROM
μPD75P518K	80-pin ceramic WQFN	EPROM

Remark xxx is a ROM code number.

(2) Quality grade

Part number	Package	Quality grade
μPD75517GF-xxx-3B9	80-pin plastic QFP (14 x 20 mm)	Standard
μPD75518GF-xxx-3B9	80-pin plastic QFP (14 x 20 mm)	Standard
μPD75P518GF-3B9	80-pin plastic QFP (14 x 20 mm)	Standard
μPD75P518K	80-pin ceramic WQFN	Not applied

Remark xxx is a ROM code number.

Caution **The Quality grade of the μPD75P518K is “Not applied.” ***
Use the μPD75P518K only for functional evaluation.

Please refer to "Quality grade on NEC Semiconductor Devices" (Document number IEI-1209) published by NEC Corporation to know the specification of quality grade on the devices and its recommended applications.

* 1.3 Differences between the μ PD75P518, μ PD75517, and μ PD75518

The μ PD75P518 differs from the μ PD75518 in that it uses one-time PROM or EPROM instead of masked ROM. Table 1-1 lists the differences between the μ PD75P518, μ PD75517, and μ PD75518. Always check these differences when intending to mass-produce an application system based on a masked ROM type after completing development using a PROM-based type.

Table 1-1. Differences between the μ PD75P518, μ PD75517, and μ PD75518

Item		μ PD75517	μ PD75518	μ PD75P518
Program memory		24448 x 8 bits Masked ROM	32640 x 8 bits Masked ROM	32640 x 8 bits One-time PROM, EPROM
Data memory		1024 x 4 bits		
Pull-up resistors for ports 4 and 5		Mask option		None
Pull-up resistors for ports 12 to 14				
Pull-down resistor for port 9				
Feedback resistor for subsystem clock				Incorporated
Pin function	Pin 4	V_{DD}		V_{PP}
	Pins 38 to 41	P33-P30		P33/MD3-P30/MD0
Electrical characteristics		The current drain and several other specifications are different for each product. For details, refer to the corresponding items in each data sheet.		
Operating voltage range		$V_{DD} = 2.7$ to 6.0 V		
Operating temperature range		-40 °C to $+85$ °C		
Package		80-pin plastic QFP (14 x 20 mm)		80-pin plastic QFP (14 x 20 mm) 80-pin ceramic WQFN
Others		Since each product has a different circuit scale and mask layout, the noise immunity and noise radiation characteristics of each product are different.		

Caution The PROM and masked ROM products have different noise immunity and noise radiation characteristics. Do not use ES products for evaluation when considering switching from PROM-based products to those using masked ROM upon the transition from preproduction to mass-production. CS products (masked ROM products) should be used in this case.

1.4 Block Diagram

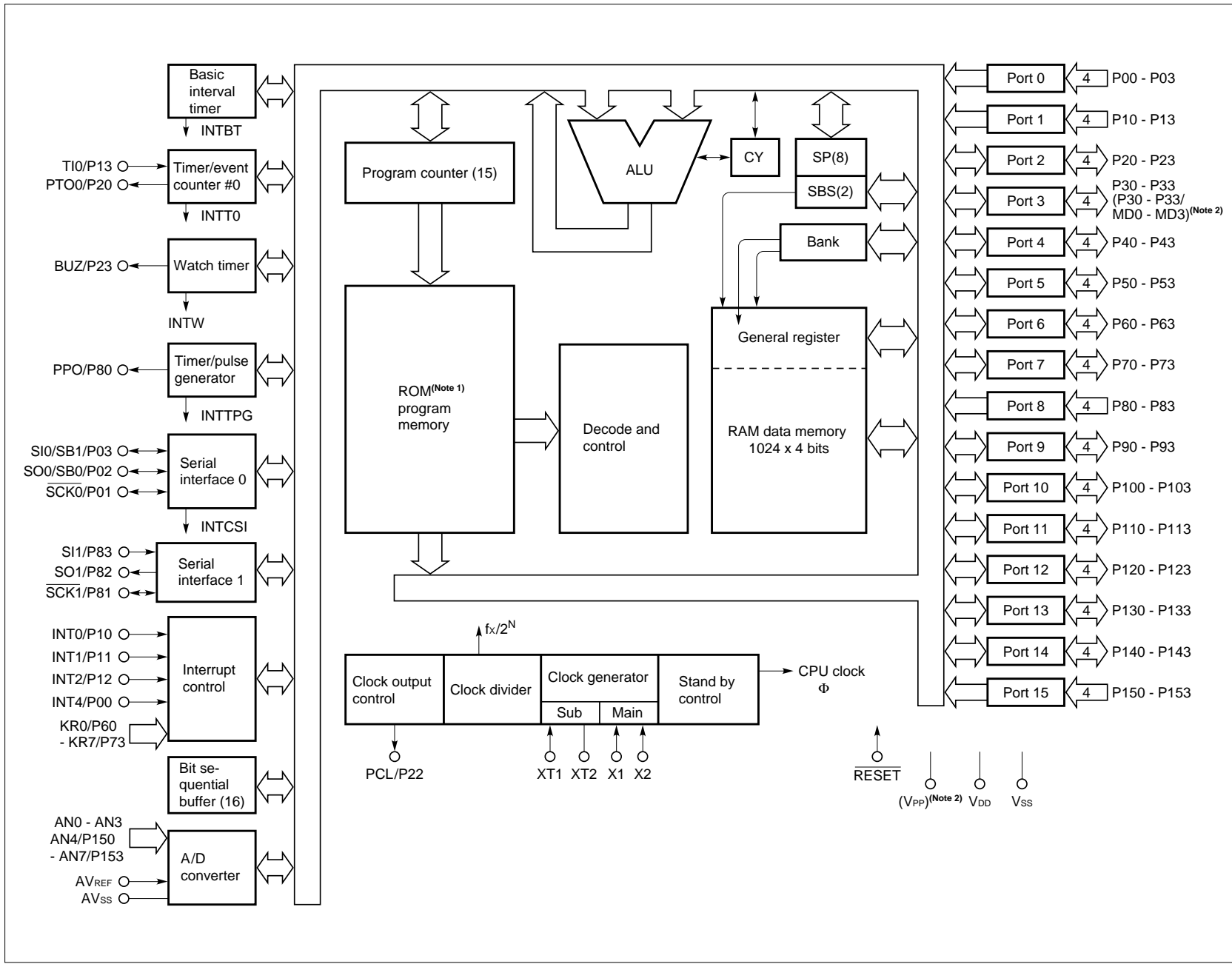

(Note 1) The type of ROM is model-dependent.
 (Note 2) Pin names in parentheses apply to the μ PD75P518.

1.5 Pin Configuration

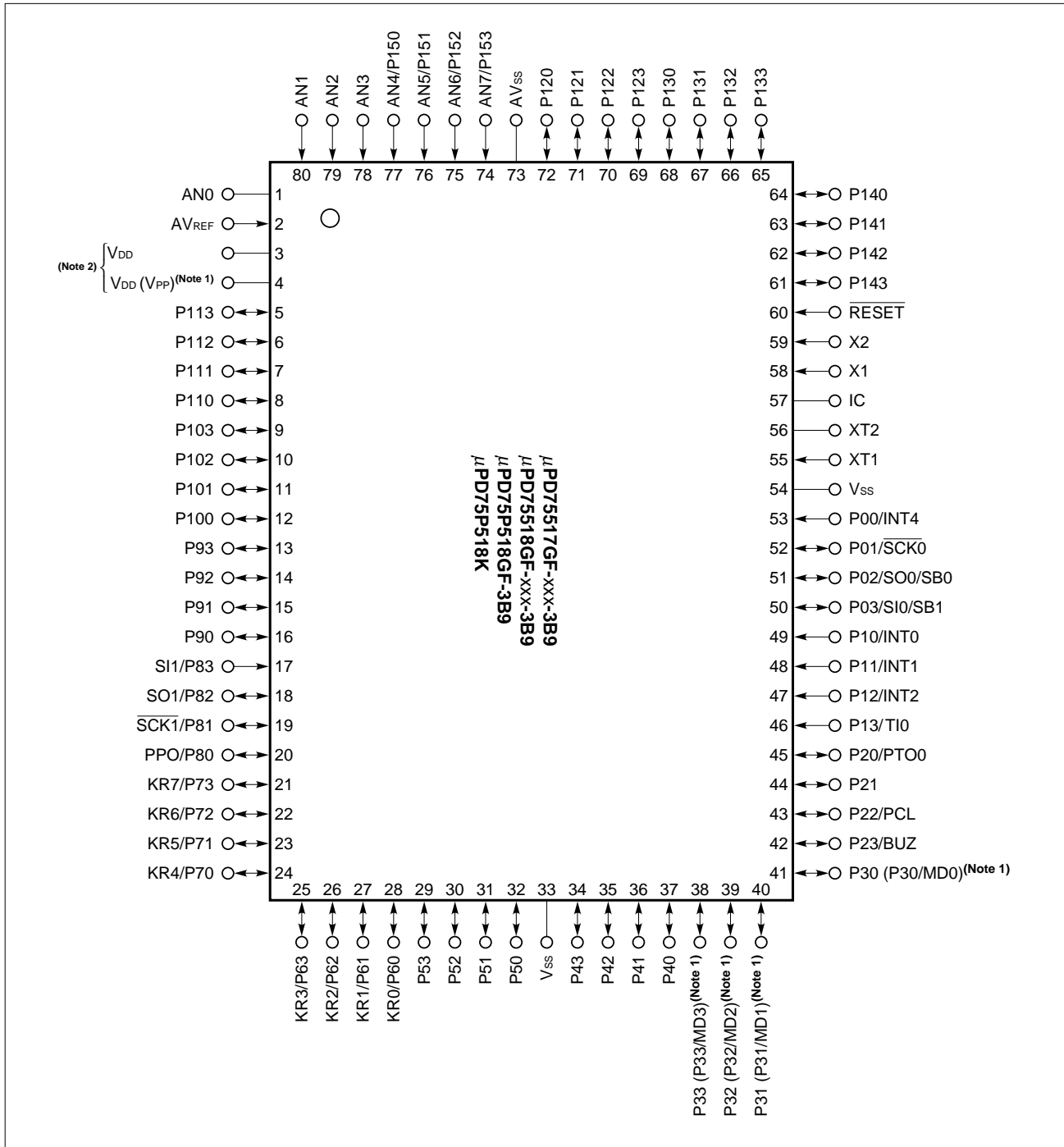

IC: Internally connected (Connect to V_{SS} , keeping the wiring as short as possible.)

(Note 1) The pin name in parentheses applies to the μ PD75P518.

(Note 2) Be sure to supply power to both V_{DD} pins.

The μ PD75P518K is not intended for use in mass-produced products; it does not offer a sufficiently high level of reliability for such applications. The use of the μ PD75P518K should be restricted to functional evaluation in experimental or trial manufacture. *

Pin name

P00-P03 : Port 0	PCL : Clock output
P10-P13 : Port 1	BUZ : Fixed frequency output
P20-P23 : Port 2	$\overline{\text{SCK0}}, \overline{\text{SCK1}}$: Serial clock I/O
P30-P33 : Port 3	SO0, SO1 : Serial output
P40-P43 : Port 4	SI0, SI1 : Serial input
P50-P53 : Port 5	SB0, SB1 : Serial bus I/O
P60-P63 : Port 6	INT4 : External vectored interrupt
P70-P73 : Port 7	INT0, INT1 : External vectored interrupt
P80-P83 : Port 8	INT2 : External test input
P90-P93 : Port 9	KR0-KR7 : Key interrupt input
P100-P103 : Port 10	PPO : Pulse output
P110-P113 : Port 11	AN0-AN7 : Analog input
P120-P123 : Port 12	AV _{REF} : Reference voltage for analog signals
P130-P133 : Port 13	AV _{SS} : Ground for analog signals
P140-P143 : Port 14	X1, X2 : Main system clock oscillation
P150-P153 : Port 15	XT1, XT2 : Subsystem clock oscillation
TI0 : Timer input	$\overline{\text{RESET}}$: Reset input
PTO0 : Timer output	V _{DD} : Positive power supply
	V _{SS} : Ground
	MD0-MD3 : Write/verify mode selection pin
	V _{PP} : Program power supply

Remark The pins in parentheses are used in the $\mu\text{PD75P518}$.

[MEMO]

Chapter 2

Pin Functions

2.1 Pin Functions

Table 2-1. Digital I/O Port Pins (1/3)

Pin	Input/output	Also used as	Function	8 bit I/O	When reset	(Note 1) I/O circuit type
P00	Input	INT4	4-bit input port (PORT0).	x	Input	Ⓑ
P01	I/O	$\overline{\text{SCK0}}$	For P01 to P03, pull-up resistors can be provided by software in units of 3 bits.			Ⓕ - A
P02	I/O	SO0/SB0				Ⓕ - B
P03	I/O	SI0/SB1				Ⓜ - C
P10	Input	INT0	4-bit input port (PORT1). Pull-up resistors can be provided by software in units of 4 bits.	x	Input	Ⓑ - C
P11		INT1				
P12		INT2				
P13		TI0				
P20	I/O	PTO0	4-bit I/O port (PORT2). Pull-up resistors can be provided by software in units of 4 bits.	x	Input	E - B
P21		—				
P22		PCL				
P23		BUZ				
P30(Note 2)	I/O	(MD0)(Note 3)	Programmable 4-bit I/O port (PORT3). I/O can be specified bit by bit. Pull-up resistors can be provided by software in units of 4 bits.	x	Input	E - C
P31(Note 2)		(MD1)(Note 3)				
P32(Note 2)		(MD2)(Note 3)				
P33(Note 2)		(MD3)(Note 3)				

(Note 1) I/O circuits enclosed in circles have a Schmitt-triggered input.

(Note 2) An LED can be driven directly.

(Note 3) The data in parentheses applies only to the $\mu\text{PD75P518}$.

Table 2-1. Digital I/O Port Pins (2/3)

Pin	Input/output	Also used as	Function	8 bit I/O	When reset	(Note 1) I/O circuit type	
P40-P43(Note 2)	I/O	—	N-ch open-drain 4-bit I/O port (PORT4). A pull-up resistor can be provided bit by bit (mask option)(Note 3). Withstand voltage is 10 V in open-drain mode.	○	High level (when a pull-up resistor is provided) or high impedance	M (M-A)(Note 4)	
P50-P53(Note 2)	I/O	—	N-ch open-drain 4-bit I/O port (PORT5). A pull-up resistor can be provided bit by bit (mask option)(Note 3). Withstand voltage is 10 V in open-drain mode.		High level (when a pull-up resistor is provided) or high impedance	M (M-A)(Note 4)	
P60	I/O	KR0	Programmable 4-bit I/O port (PORT6). I/O can be specified bit by bit. Pull-up resistors can be provided by software in units of 4 bits.	○	Input	Ⓕ - C	
P61		KR1					
P62		KR2					
P63		KR3					
P70	I/O	KR4	4-bit I/O port (PORT7). A pull-up resistor can be specified by software in units of 4 bits.		○	Input	Ⓕ - A
P71		KR5					
P72		KR6					
P73		KR7					
P80	I/O	PPO	4-bit input port (PORT8)	x		Input	E
P81	I/O	SCK1					
P82	I/O	SO1					
P83	Input	SI1					
P90-P93	I/O	—	4-bit I/O port (PORT9). A pull-down resistor can be provided bit by bit (mask option)(Note 3).		x	Low level (when a pull-down resistor is provided) or high impedance	V
P100-P103	I/O	—	4-bit I/O port (PORT10)		x	Input	E
P110-P113	I/O	—	4-bit I/O port (PORT11)			Input	E

(Note 1) I/O circuits enclosed in circles have a Schmitt-triggered input.

(Note 2) An LED can be driven directly.

(Note 3) The μ PD75P518 does not contain pull-up or pull-down resistors specified by the mask option.

(Note 4) The data in parentheses applies only to the μ PD75P518.

Table 2-1. Digital I/O Port Pins (3/3)

Pin	Input/output	Also used as	Function	8 bit I/O	When reset	I/O circuit type
P120-P123	I/O	—	N-ch open-drain, 4-bit port (PORT12). A pull-up resistor can be provided bit by bit (mask option)(Note 1). Withstand voltage is 10 V in open-drain mode.	x	High level (when a pull-up resistor is provided) or high impedance	M (M-A)(Note 2)
P130-P133	I/O	—	N-ch open-drain, 4-bit port (PORT13). A pull-up resistor can be provided bit by bit (mask option)(Note 1). Withstand voltage is 10 V in open-drain mode.	x	High level (when a pull-up resistor is provided) or high impedance	M (M-A)(Note 2)
P140-P143	I/O	—	N-ch open-drain, 4-bit port (PORT14). A pull-up resistor can be provided bit by bit (mask option)(Note 1). Withstand voltage is 10 V in open-drain mode.	x	High level (when a pull-up resistor is provided) or high impedance	M (M-A)(Note 2)
P150-P153	Input	AN4-AN7	4-bit input port (PORT15)	x	Input	Y-A

(Note 1) The μ PD75P518 does not contain pull-up or pull-down resistors specified by the mask option.

(Note 2) The data in parentheses applies only to the μ PD75P518.

Table 2-2. Non-port Pin Functions (1/2)

Pin	Input/output	Also used as	Function	When reset	(Note 1) I/O circuit type
TI0	Input	P13	External event pulse input for timer/event counter	—	Ⓑ - C
PTO0	Output	P20	Timer/event counter output	Input	E - B
PCL	Output	P22	Clock output	Input	E - B
BUZ	Output	P23	Fixed frequency output (for buzzer or system clock trimming)	Input	E - B
$\overline{\text{SCK0}}$	I/O	P01	Serial clock I/O	Input	Ⓕ - A
SO0/SB0	I/O	P02	Serial data output or serial bus I/O	Input	Ⓕ - B
SI0/SB1	I/O	P03	Serial data input or serial bus I/O	Input	Ⓜ - C
INT4	Input	P00	Edge detection vectored interrupt input (Either a rising or falling edge is detected.)	—	Ⓑ
INT0	Input	P10	Edge detection vectored interrupt input	Synchronous	Ⓑ - C
INT1		P11	(The edge to be detected is selectable.)	Asynchronous	
INT2	Input	P12	Edge detection testable input (Rising edge detection)	Asynchronous	Ⓑ - C
KR0-KR3	Input	P60-P63	Parallel falling edge detection testable input	Input	Ⓕ - C
KR4-KR7	Input	P70-P73	Parallel falling edge detection testable input	Input	Ⓕ - A
$\overline{\text{SCK1}}$	I/O	P81	Serial clock I/O	Input	Ⓕ
SO1	I/O	P82	Serial data output	Input	E
SI1	Input	P83	Serial data input	Input	Ⓑ
AN0-AN3	Input	—	Analog input to A/D converter	—	Y
AN4-AN7		P150-P153			Y - A
AV _{REF}	Input	—	A/D converter reference voltage input	—	Z
AV _{SS}	—	—	A/D converter reference GND potential	—	—
X1, X2	Input	—	Connection to a crystal/ceramic resonator for main system clock generation. When external clock is used, it is input to X1, and its inverted signal is input to X2.	—	—
XT1	Input	—	Connection to a crystal resonator for subsystem clock generation. When external clock is used, it is input to XT1, and XT2 is left open.(Note 2)	—	—
XT2	—				

(Note 1) The circuits enclosed in circles have a Schmitt-triggered input.

(Note 2) When the subsystem clock is not used, see (5) in Section 5.2.2.

Table 2-2. Non-port Pin Functions (2/2)

Pin	Input/output	Also used as	Function	When reset	(Note) I/O circuit type
RESET	Input	—	System reset input	—	ⓑ
PPO	I/O	P80	Timer/pulse generator pulse output	Input	E
MD0-MD3	I/O	P30-P33	Provided only in μ PD75P518. Selection of program memory (PROM) write/verify mode.	Input	E - C
IC	—	—	Internally connected. Connect to V_{SS} , keeping the wiring as short as possible.	—	—
V_{PP}	—	—	Provided only in μ PD75P518. Program voltage application for program memory (PROM) write/verify operation. Normally connected to V_{DD} , keeping the wiring as short as possible. +12.5 V is applied for PROM write/verify operation.	—	—
V_{DD}	—	—	Positive power supply	—	—
V_{SS}	—	—	GND potential	—	—

*

(Note) The circuits enclosed in circles have a Schmitt-triggered input.

2.2 Pin Functions

- 2.2.1 P00-P03 (PORT0) : Dual Function Pins Used Also for INT4, $\overline{\text{SCK0}}$, SO0/SB0 and SI0/SB1**
- P10-P13 (PORT1) : Dual Function Pins Used Also for INT0-INT2, and TI0**
- P80-P83 (PORT8) : Dual Function Pins Used Also for PPO, $\overline{\text{SCK1}}$, SO1, and SI1**
- P150-P153 (PORT15): Dual Function Pins Used Also for AN4-AN7**

These are the input pins of the 4-bit input ports: Ports 0, 1, 8, and 15.

Ports 0, 1, 8, and 15 function as input ports, and also have the functions described below.

- Port 0 : Vectored interrupt I/O (INT4)
Serial interface I/O ($\overline{\text{SCK0}}$, SO0/SB0, SI0/SB1)
- Port 1 : Vectored interrupt input (INT0, INT1)
Edge detection test input (INT2)
External event pulse input (TI0) for timer/event counter
- Port 8 : Timer/pulse generator pulse output (PPO)
Serial interface I/O ($\overline{\text{SCK1}}$, SO1, SI1)
- Port 15 : A/D converter input (AN4 to AN7)

Input is always enabled for each pin of ports 0, 1, 8, and 15 regardless of the operation status of the other function of the pin.

Schmitt-triggered inputs are used for the pins of ports 0, 1, and 8 (excluding P80 and P82) to prevent malfunction due to noise. In addition, a noise eliminator is provided for P10. (See **(2)** of **Section 6.3.**)

Use of built-in pull-up resistors can be software-selected for a set of three bits of port 0 (P01 to P03) and for a set of four bits of port 1 (P10 to P13) at a time. This is done by manipulating pull-up resistor specification register group A.

A $\overline{\text{RESET}}$ signal input places these pins in the input port mode.

2.2.2 P20-P23 (PORT2) : I/O Pins Used Also for PTO0, PCL, and BUZ P30-P33 (PORT3), P60-P63 (PORT6), P70-P73 (PORT7), P90-P93 (PORT9), P100-P103 (PORT10), P110-P113 (PORT11): Three- State I/O

These pins are the I/O pins of the 4-bit I/O ports with output latches, ports 2, 3, 6, 7, and 9 to 11.

Ports 2, 6, and 7 function as I/O ports, and also have the following functions:

- Port 2 : Timer/event counter (PTO0)
Clock output (PCL)
Fixed frequency output (BUZ)
- Ports 6 and 7: Key interrupt input (KR0-KR3, KR4-KR7)

Port 3 is a high-current output. It can directly drive the LED.

An I/O mode is selected by the port mode register. The I/O mode of ports 2, 7, and 9 to 11 can be selected in units of 4 bits, and the I/O mode of ports 3 and 6 can be selected bit by bit.

The use of built-in pull-up resistors can be software-selected for ports 2, 3, 6, and 7 in 4-bit units. This can be done by manipulating pull-up resistor specification register group A (POGA). For ports 4 and 5, the use of built-in pull-up resistors can be specified bit by bit by mask option. For port 9, the use of built-in pull-down resistors can be specified bit by bit by mask option.

Ports 6 and 7 can be paired for 8-bit I/O.

A $\overline{\text{RESET}}$ input clears the output latches in the ports to zero, places ports 2, 3, 6, 7, 10, and 11 in the input mode (output high-impedance state), and drives port 9 low if pull-down resistors are provided or causes port 9 to go into a high-impedance state.

2.2.3 P40-P43 (PORT4), P50-P53 (PORT5), P120-P123 (PORT12), P130-P133 (PORT13), P140-P143 (PORT14): N-ch Open-Drain I/O

These pins are the I/O pins of the N-ch open-drain, 4-bit I/O ports with output latches, ports 4, 5, and 12 to 14.

Each pin is an intermediate withstand voltage (10 V) I/O, so it is suitable for interface with a peripheral circuit operating on a different power supply voltage. For each pin, a pull-up resistor can be provided by mask option.

A $\overline{\text{RESET}}$ input clears the output latch of each port to zero, and drives each pin high if a pull-up resistor is provided or places each pin in high-impedance state.

The input mode is selected with the port mode register in 4-bit units.

Ports 4 and 5, and ports 12 and 13 are paired respectively for 8-bit I/O.

2.2.4 TI0: Input Used Also for Port 1

This is an external event pulse input pin for the programmable timer/event counter.

A Schmitt-triggered input is used for the TI0 pin.

2.2.5 PTO0: Output Used Also for Port 2

This is the output signal pin of the time-out flip-flop for the programmable timer/event counter. Square-wave pulses appear on this pin. To output a signal from the programmable timer/event counter, the output latch P20 must be cleared to zero, and the bit for port 2 in the port mode register must be set to 1 (output mode).

The output is cleared to 0 by the timer start instruction.

2.2.6 PCL: Output Used Also for Port 2

This is the output pin of the programmable clock output circuit. It is used to supply the clock pulse to a peripheral LSI circuit such as a slave microcomputer or A/D converter.

A $\overline{\text{RESET}}$ signal clears the clock mode register (CLOM) to zero, disabling clock output, then the pin is placed in the normal mode to function as a normal port.

2.2.7 BUZ: Output Used Also for Port 2

This is a frequency output pin. A fixed frequency (2.048 kHz) output on this pin can be used for sounding the buzzer or trimming the system clock frequency. This pin is used also as the P23 pin, and can be used only when bit 7 (WM7) of the clock mode register (WM) is set to 1.

A $\overline{\text{RESET}}$ signal clears WM7 to 0, then this pin is placed in the normal operation mode as a general port.

2.2.8 $\overline{\text{SCK0}}$, SO0/SB0 , SI0/SB1 : Three-State I/O Used Also as Port 0 $\overline{\text{SCK1}}$, SO1 , SI1 : Three-State I/O Used Also as Port 8

These are I/O pins for serial interface. They operate according to the setting of the serial operation mode registers (CSIM0, CSIM1).

A $\overline{\text{RESET}}$ signal stops serial interface operation and places these pins in the input port mode.

A Schmitt-triggered input is used for each pin except P80 and P82.

2.2.9 INT4: Input Used Also as Port 0

INT4 is an external vectored interrupt input pin, which is rising edge active as well as falling edge active. When a signal applied to this pin goes from low to high or from high to low, the interrupt request flag is set.

INT4 is an asynchronous input, and can accept a signal with some high level width or low level width regardless of what the CPU clock is.

The INT4 pin can also be used to release the STOP and HALT modes. A Schmitt-triggered input is used for this pin.

2.2.10 INT0, INT1: Inputs Used Also for Port 1

These are edge detection vectored interrupt input pins. INT0 has a noise eliminator. The edge to be detected can be selected using the edge detection mode registers (IM0, IM1).

(1) INT0 (bits 0 and 1 of IM0)

- (a) Rising edge active
- (b) Falling edge active
- (c) Both rising and falling edges active
- (d) External interrupt signal input disabled

(2) INT1 (bit 0 of IM1)

- (a) Rising edge active
- (b) Falling edge active

INT0 has a noise eliminator. Two different sampling clocks for noise elimination can be switched. The acceptable width of a signal depends on the CPU clock.

INT1 is an asynchronous input, and can accept a signal with some high level width regardless of what the CPU clock is.

A $\overline{\text{RESET}}$ input clears IM0 and IM1 to zero, selecting rising edge active.

The INT1 pin can also be used to release the STOP and HALT modes, but the INT0 pin \star cannot.

Schmitt-triggered inputs are used for the INT0 and INT1 pins.

2.2.11 INT2: Input Used Also for Port 1

This is a rising and falling edge active, external test input pin. When INT2 is selected with the edge detection mode register (IM2), or when the signal applied to this pin goes high, the internal test flag (IRQ2) is set.

INT2 is an asynchronous input, and can accept a signal with some high level width regardless of the operating clock of the CPU.

A $\overline{\text{RESET}}$ signal clears IM2 to zero. In this case, the test flag (IRQ2) is set by a rising edge on the INT2 pin.

- * The INT2 pin can also be used to release the STOP and HALT modes. A Schmitt-triggered input is used for this pin.

2.2.12 KR0-KR3: Inputs Used Also for Port 6 KR4-KR7: Inputs Used Also for Port 7

KR0 to KR7 are key interrupt input pins. An interrupt is caused when parallel falling edges are detected on them.

The interrupt format can be specified with the edge detection mode register (IM2).

A $\overline{\text{RESET}}$ signal places these pins in the port 6 and 7 input modes.

2.2.13 PPO: Output Uses Also as Port 8

This is the pin for outputting a pulse signal from the timer/pulse generator. A PWM or square wave pulse signal can be output on this pin. If no pulse output is needed, the PPO pin can be used as a 1-bit output port.

When a $\overline{\text{RESET}}$ signal occurs or when the high-impedance mode is set by the timer/pulse generator mode register (TPGM), the PPO pin enters the input mode (output high-impedance state).

2.2.14 AN0-AN3 AN4-AN7: Input Used as Port 15

These pins are analog signal inputs to the A/D converter.

2.2.15 AV_{REF}

This is the reference voltage input pin for the A/D converter.

2.2.16 AV_{SS}

This is the ground pin for the A/D converter.

- * Always use the same voltage as that of the V_{SS} pin.

2.2.17 X1, X2

These pins are used for connection to a crystal or ceramic resonator for main system clock generation.

An external clock can also be applied.

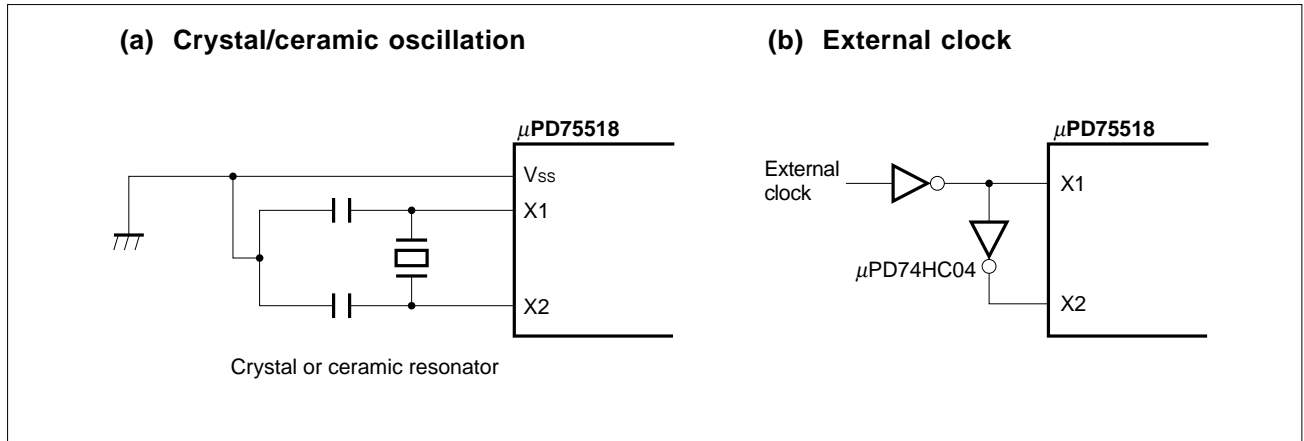

2.2.18 XT1, XT2

These pins are used for connection to a crystal resonator for subsystem clock oscillation.

An external clock can also be applied.

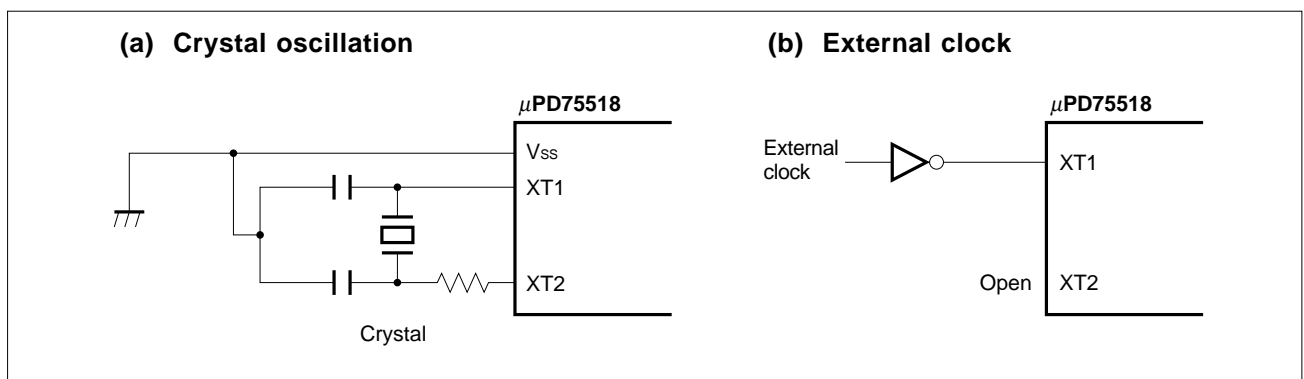

Remark When using no subsystem clock, see (5) in Section 5.2.2.

2.2.19 $\overline{\text{RESET}}$

This is the pin for active-low reset input.

The $\overline{\text{RESET}}$ input is asynchronous. When a signal with certain low level width is applied to the pin, a $\overline{\text{RESET}}$ signal is generated to cause a system reset, which has priority over any other operations.

The $\overline{\text{RESET}}$ signal is used for normal CPU initialize/start operation, and is also used to release the STOP or HALT mode.

A Schmitt-triggered input is used for the $\overline{\text{RESET}}$ input pin.

2.2.20 IC

* The internally connected (IC) pin is used to set the μ PD75518 to test mode for inspection prior to shipping. In normal operation, connect the IC pin to the V_{SS} pin, keeping the wiring as short as possible.

When the wiring between the IC pin and the V_{SS} pin is too long, or noise is generated on the IC pin, a potential difference may occur between the IC pin and the V_{SS} pin. This may cause your program to malfunction.

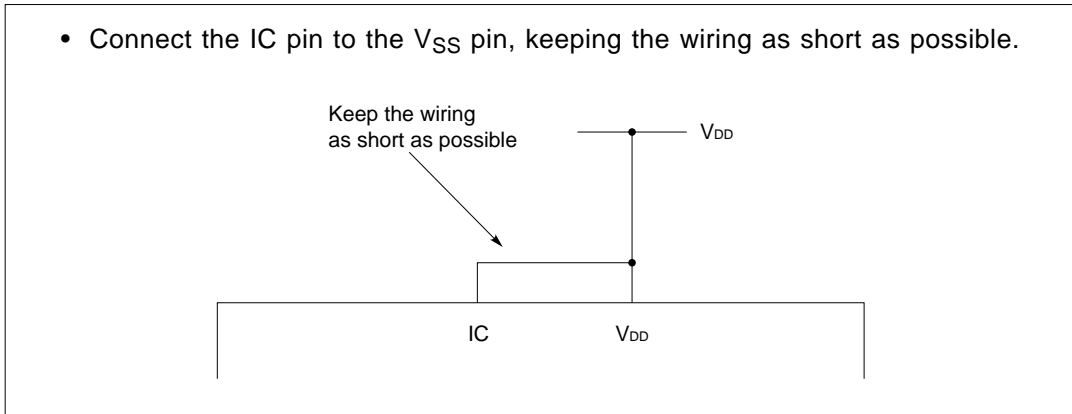

2.2.21 MD0-MD3 (for μ PD75P518 only)

These pins are provided for the μ PD75P518 only.

MD0 to MD3 select a mode for program memory (PROM) write/verify operation.

2.2.22 V_{PP} (for μ PD75P518 only)

This is a program voltage input pin for program memory (PROM) write/verify operation.

For normal use, connect this pin to V_{DD} , keeping the wiring as short as possible.

2.2.23 V_{DD}

This is the positive power supply pin.

2.2.24 V_{SS}

This is the ground pin.

2.3 Pin Input/Output Circuits

Figure 2-1 shows schematic diagrams of the I/O circuitry of the μ PD75518.

Figure 2-1. Pin Input/Output Circuits (1/3)

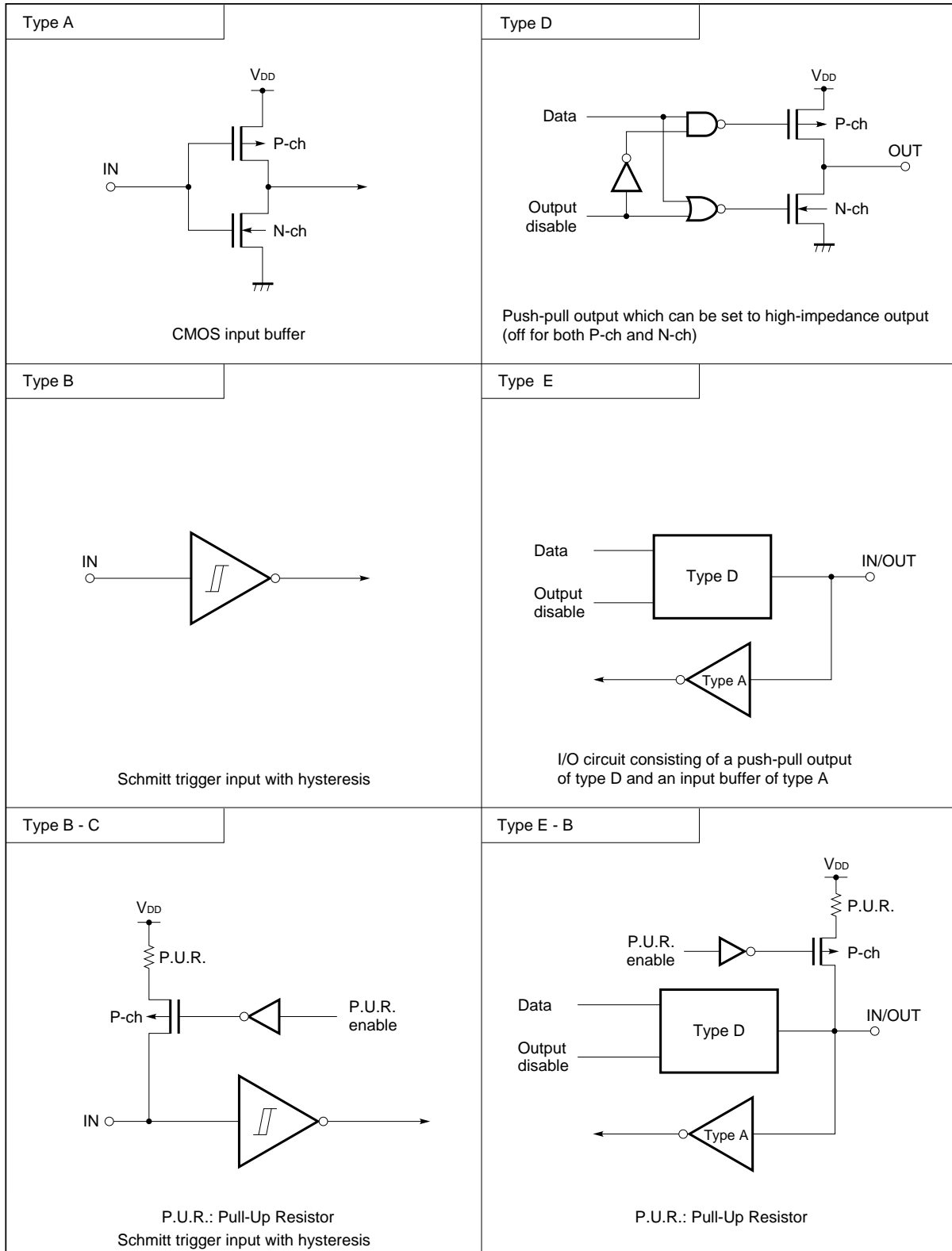

Figure 2-1. Pin Input/Output Circuits (2/3)

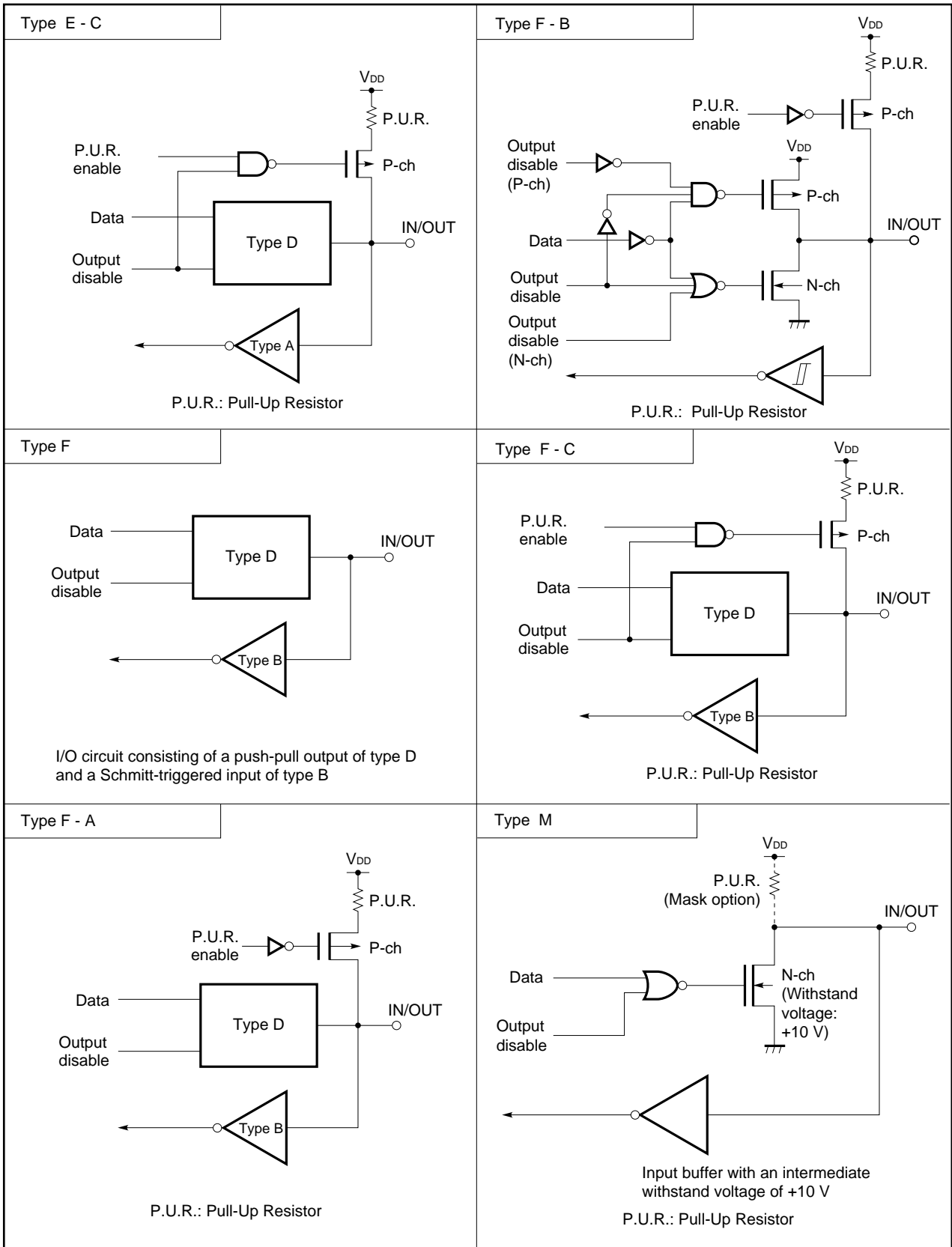
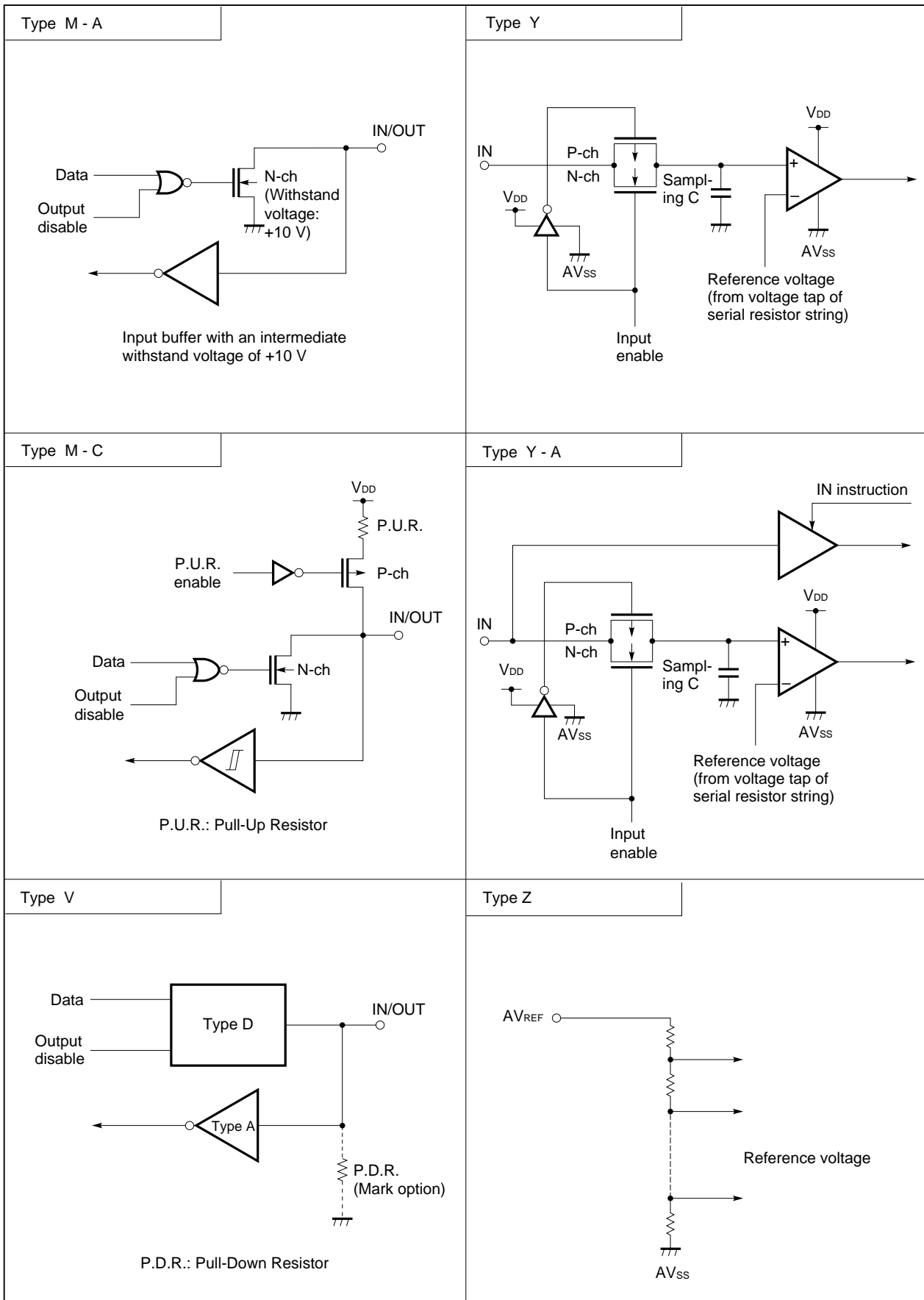

Figure 2-1. Pin Input/Output Circuits (3/3)



2.4 Connection of Unused Pins

Table 2-3. Recommended Connection of Unused Pins (1/2)

Pin	Recommended connection
P00/INT4	To be connected to V_{SS}
P01/SCK0	To be connected to V_{SS} or V_{DD}
P02/SO0/SB0	
P03/SI1/SB1	
P10/INT0-P12/INT2	To be connected to V_{SS}
P13/TI0	
P20/PTO0	Input state: To be connected to V_{SS} or V_{DD}
P21	Output state: To be left open
P22/PCL	
P23/BUZ	
P30-P33 (P30/MD0-P33/MD3)(Note)	
P40-P43	
P50-P53	
P60/KR0-P63/KR3	
P70/KR4-P73/KR7	
P80/PPO	To be connected to V_{SS} or V_{DD}
P81/SCK1	
P82/SO1	
P83/SI1	
P90-P93	Input state: To be connected to V_{SS} or V_{DD}
P100-P103	Output state: To be left open
P110-P113	
P120-P123	
P130-P133	
P140-P143	
P150/AN4-P153/AN7	To be connected to V_{SS}
AN0-AN3	
XT1	To be connected to V_{SS} or V_{DD}
XT2	To be left open
AV_{REF}	To be connected to V_{SS}
AV_{SS}	

Table 2-3. Recommended Connection of Unused Pins (2/2)

Pin	Recommended connection
IC	To be connected to V_{SS} , keeping the wiring as short as possible *
(V_{PP})(Note)	To be connected to V_{DD} , keeping the wiring as short as possible
(Note) The pins indicated in parentheses are provided only for the μ PD75P518.	

2.5 Selection of a Mask Option

The following mask options are provided for pins. For the μ PD75P518, however, pull-up or pull-down resistors are not specified by the mask option. The following pins of the μ PD75P518 are always open. *

(1) Specification of built-in pull-up and pull-down resistors

Table 2-4. Selection of Pull-up and Pull-down Resistors

Pin	Mask option	
P40-P43, P50-P53, P120-P123, P130-P133, P140-P143	<1> Pull-up resistors provided (Can be specified bit by bit.)	<2> No pull-up resistor provided (Can be specified bit by bit.)
P90-P93	<1> Pull-down resistors provided (Can be specified bit by bit.)	<2> No pull-down resistor provided (Can be specified bit by bit.)

(2) Specification of built-in feedback resistors for subsystem clock oscillation

Table 2-5. Selection of Feedback Resistors

Pin	Mask option	
XT1, XT2	<1> Feedback resistors provided (when a subsystem clock is used)	<2> No feedback resistors provided (when no subsystem clock is used)

Caution Even if built-in feedback resistors are provided when no subsystem clock is used, operation is not affected except for increased power supply current I_{DD} .

[MEMO]

Chapter 3

Data Memory Operations and Memory Map

The 75X architecture of the μ PD75518 has the following features:

- Internal RAM of up to 4K words x 4 bits (12-bit address)
- Up to eight general registers x 4 bits x 16 banks
- Peripheral hardware expansibility

To provide these features, the following are used:

- (1) Data memory bank structure
- (2) General register bank structure
- (3) Memory-mapped I/O

This chapter explains these topics.

3.1 Data Memory Bank Structure and Addressing Modes

3.1.1 Data Memory Bank Structure

In the μ PD75518, addresses 000H to 3FFH in data memory space are assigned to static RAM (1024 words x 4 bits), and addresses F80H to FFFH are assigned to peripheral hardware (such as I/O ports and timers). To address a 12-bit location in this data memory space (4K words x 4 bits), the μ PD75518 uses such a memory bank structure that the low-order eight bits are specified with an instruction directly or indirectly, and the high-order four bits are used to specify a memory bank.

To specify a memory bank (MB), two hardware items are incorporated:

- Memory bank enable flag (MBE)
- Memory bank select register (MBS)

The MBS is a register used to select a memory bank. With the μ PD75518, the register can be set to 0, 1, 2, 3, or 15. The MBE is a flag used to determine whether the memory bank selected using the MBS is valid. As shown in Figure 3-1, when the MBE is set to 0, a certain memory bank is always selected regardless of the setting of the MBS. When the MBE is set to 1, memory bank selection depends on the setting of the MBS, thus enabling data memory space expansion.

In addressing data memory space, the MBE is usually set to 1 (MBE = 1), and data memory in the memory bank specified in the MBS is operated. However, the MBE = 0 mode or MBE = 1 mode can be selected for each step of processing for more efficient programming.

	Applicable program processing	Effect
MBE = 0 mode	• Interrupt processing	MBS save/restoration becomes unnecessary.
	• Processing that repeats internal hardware and static RAM operations	MBS modification becomes unnecessary.
	• Subroutine processing	MBS save/restoration becomes unnecessary.
MBE = 1 mode	• Usual program processing	

Figure 3-1. Use of MBE = 0 Mode and MBE = 1 Mode

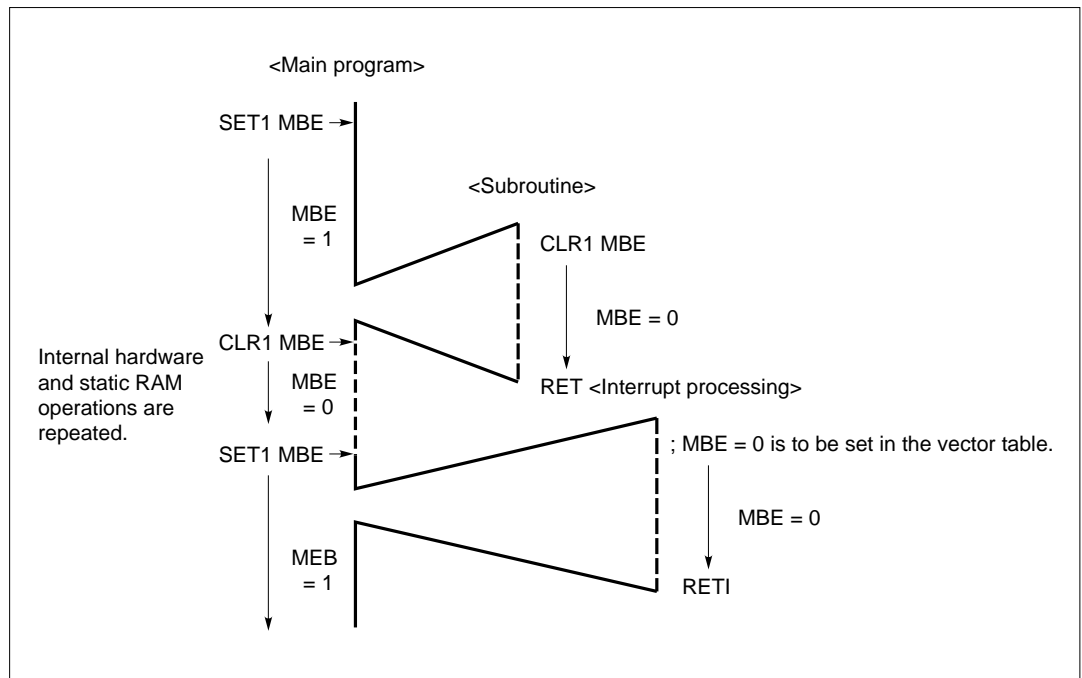

Remark **—————** MBE = 1, **-----** MBE = 0

The contents of the MBE are automatically saved or restored at the time of subroutine processing, so that the MBE can be freely modified during subroutine processing. In interrupt processing, the MBE is automatically saved or restored, and when interrupt processing is started, the contents of the MBE can be specified for the interrupt processing by setting the interrupt vector table. This speeds up interrupt processing.

The setting of the MBS can be modified for subroutine processing or interrupt processing by saving or restoring the MBS with the PUSH or POP instruction.

The MBE is set using the SET1 or CLR1 instruction. The MBS is set using the SEL instruction.

Example 1. The MBE is cleared, and a fixed memory bank is used.

```
CLR1  MBE  ; MBE <- 0
```

Example 2. Memory bank 1 is selected.

```
SET1  MBE  ; MBE <- 1
SEL   MB1  ; MBS <- 1
```

3.1.2 Data Memory Addressing Modes

With the 75X architecture of the μ PD75518, seven addressing modes summarized in Figure 3-2 and Table 3-1 are available to address data memory space efficiently for each bit length of data to be processed. These addressing modes enable more efficient programming.

Figure 3-2. Data Memory Organization and Addressing Range of Each Addressing Mode

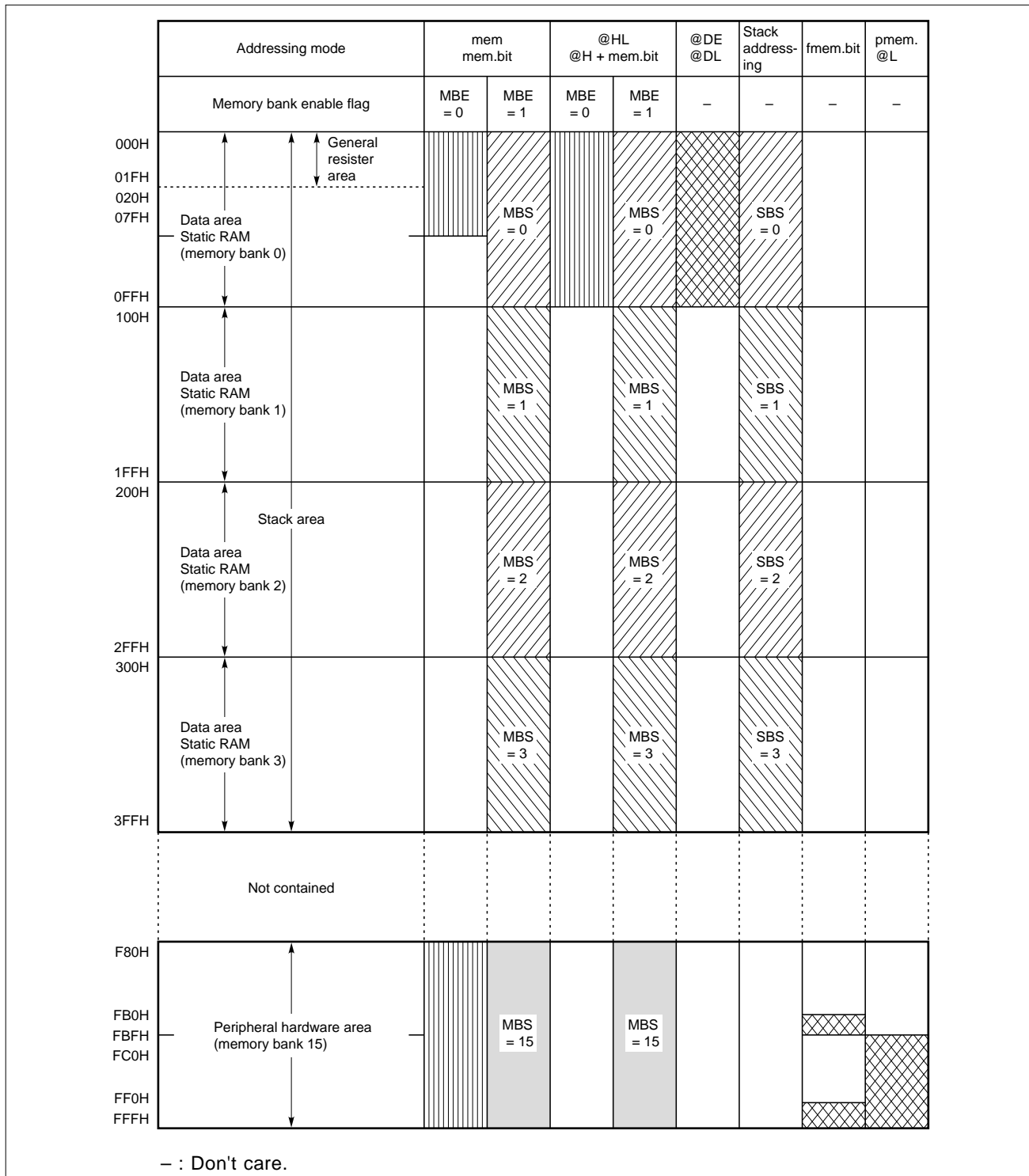

Table 3-1. Addressing Modes

Addressing mode	Representation format	Specified address
1-bit direct addressing	mem.bit	Bit specified by bit at the address specified by MB and mem. In this case: When MBE = 0 and $\left[\begin{array}{l} \text{mem} = 00\text{H}-7\text{FH}, \text{MB} = 0 \\ \text{mem} = 80\text{H}-\text{FFH}, \text{MB} = 15 \end{array} \right.$ When MBE = 1, MB = MBS
4-bit direct addressing	mem	Address specified by MB and mem. In this case: When MBE = 0 and $\left[\begin{array}{l} \text{mem} = 00\text{H}-7\text{FH}, \text{MB} = 0 \\ \text{mem} = 80\text{H}-\text{FFH}, \text{MB} = 15 \end{array} \right.$ When MBE = 1, MB = MBS
8-bit direct addressing		Address specified by MB and mem (mem: even address). In this case: When MBE = 0 and $\left[\begin{array}{l} \text{mem} = 00\text{H}-7\text{FH}, \text{MB} = 0 \\ \text{mem} = 80\text{H}-\text{FFH}, \text{MB} = 15 \end{array} \right.$ When MBE = 1, MB = MBS
4-bit register indirect addressing	@HL	Address specified by MB and HL. In this case, MB = MBE-MBS
	@HL+ @HL-	Address specified by MB and HL. In this case, MB = MBE-MBS. HL+ automatically increments the L register after addressing. HL- automatically decrements the L register after addressing.
	@DE	Address specified by DE in memory bank 0
	@DL	Address specified by DL in memory bank 0
8-bit register indirect addressing	@HL	Address specified by MB and HL. In this case, MB = MBE-MBS (Bit 0 of the L register is ignored.)
Bit manipulation addressing	fmem.bit	Bit specified by bit at the address specified by fmem. In this case, fmem = $\left[\begin{array}{l} \text{FB}0\text{H}-\text{FB}\text{FH} \text{ (interrupt-related hardware)} \\ \text{FF}0\text{H}-\text{FF}\text{FH} \text{ (I/O ports)} \end{array} \right.$
	pmem.@L	Bit specified by the low-order two bits of the L register at the address specified by the high-order 10 bits of pmem and the high-order two bits of the L register. In this case, pmem = FC0H-FFFH
	@H+mem.bit	Bit specified by bit at the address specified by MB, H, and the low-order four bits of mem. In this case, MB = MBE-MBS
Stack addressing	—	Address specified by the stack pointer (SP) in memory bank 0, 1, 2, or 3 selected by the stack bank select register (SBS)

(1) 1-bit direct addressing (mem.bit)

In this addressing mode, the operand of an instruction can directly specify any bit in the entire data memory space.

A particular memory bank (MB) is always used in this addressing mode. In the MBE = 0 mode, when an address from 000H to 07FH is specified in the operand, memory bank 0 (MB = 0) is always used. When an address from F80H to FFFH is specified, memory bank 15 (MB = 15) is always used. Accordingly, both the data area ranging from 000H to 07FH and the peripheral hardware area ranging from F80H to FFFH can be addressed in the MBE = 0 mode.

In the MBE = 1 mode, MB = MBS, and specifiable data memory space can be expanded.

This addressing mode can be applied to four instructions: bit set and reset instructions (SET1 and CLR1), and bit test instructions (SKT and SKF).

Example FLAG1 is set, FLAG2 is reset, and whether FLAG3 is zero is tested.

```
FLAG1 EQU 03FH.1 ; Bit 1 at address 3FH
```

```
FLAG2 EQU 087H.2 ; Bit 2 at address 87H
```

```
FLAG3 EQU 0A7H.0 ; Bit 0 at address A7H
```

```
SET1 MBE ; MBE <- 1
```

```
SEL MB0 ; MBS <- 0
```

```
SET1 FLAG1 ; FLAG1 <- 1
```

```
CLR1 FLAG2 ; FLAG2 <- 0
```

```
SKF FLAG3 ; FLAG3 = 0?
```

(2) 4-bit direct addressing (mem)

In this addressing mode, the operand of an instruction directly specifies any area in the data memory space in units of four bits.

As with the 1-bit direct addressing mode, in the MBE = 0 mode, a fixed space consisting of the data area ranging from 000H to 07FH and the peripheral hardware area ranging from F80H to FFFH can be addressed. In the MBE = 1 mode, MB = MBS, and specifiable data memory space can be expanded to the entire space.

This addressing mode can be applied to the MOV, XCH, INCS, IN, and OUT instructions.

Caution **Less efficient program processing results if data associated with an I/O port is stored in the static RAM area of bank 1 as in Example 1. The modification of the MBS, as contained in Example 2, becomes unnecessary in the programming if data associated with an I/O port is stored at addresses 000H to 07FH of bank 0.**

Example 1. The data contained in BUFF is output on port 8.

```
BUFF EQU 11AH      ; BUFF located at address 11AH
SET1 MBE           ; MBE <- 1
SEL  MB1           ; MBS <- 1
MOV  A,BUFF        ; A <- (BUFF)
SEL  MB15          ; MBS <- 15
OUT  PORT8,A       ; PORT8 <- A
```

Example 2. Data on port 4 is entered, and is saved in DATA1.

```
DATA1 EQU 5FH      ; DATA1 located at address 5FH
CLR1 MBE           ; MBE <- 0
IN   A,PORT4       ; A <- PORT4
MOV  DATA1,A      ; (DATA1) <- A
```

(3) 8-bit direct addressing (mem)

In this addressing mode, the operand of an instruction directly specifies any area in the data memory space in units of eight bits.

The operand can specify an even address. The 4-bit data at the address specified in the operand and the 4-bit data at the address incremented by 1 are processed as a pair on an 8-bit basis with the 8-bit accumulator (XA register pair).

A memory bank is specified in the same way as the 4-bit direct addressing.

This addressing mode can be applied to the MOV, XCH, IN, and OUT instructions.

Example 1. Eight-bit data from port 4 and port 5 is transferred to addresses 20H and 21H, and the original data at addresses 20H and 21H is output on ports 6 and 7.

```
DATA EQU 020H
      CLR1 MBE ; MBE <- 0
      IN XA,PORT4 ; XA <- PORT5 and PORT4
      XCH XA,DATA ; XA <—> (21H, 20H)
      OUT PORT6,XA ; Ports 7 and 6 <- XA
```

Example 2. Eight-bit data is latched into the serial interface shift register 0 (SIO0), and the transfer data is set at the same time.

```
SEL MB15 ; MBS <- 15
XCH XA,SIO0 ; XA <—> SIO0
```

(4) 4-bit register indirect addressing (@rpa)

In this addressing mode, the pointer (general register pair) specified in the operand of an instruction indirectly specifies a data memory space in units of four bits.

There are three types of data pointers. One is the HL register pair, which can specify any area in the data memory space when MB = MBE·MBS is specified. The other two are the DE register pair and DL register pair, with which memory bank 0 is always used regardless of how the MBE and MBS are specified. More efficient programming is possible by selecting a data pointer according to a data memory bank to be used.

When the HL register pair is specified, the L register can be incremented or decremented by one in the automatic increment or automatic decrement mode each time an instruction is executed, thus simplifying the program step.

Example The data at 50H to 57H is transferred to 110H to 117H.

```

DATA1 EQU 57H
DATA2 EQU 117H
      SET1 MBE           ; MBE <- 1
      SEL  MB1          ; MBS <- 1
      MOV  D,#DATA1 SHR4 ; D <- 5
      MOV  HL,#DATA2 AND 0FFH ; HL <- 17H
LOOP: MOV  A,@DL        ; A <- (DL)
      XCH  A,@HL-       ; A <-> (HL), L <- L - 1
      BR   LOOP

```

The addressing mode using the HL register pair as the data pointer finds a wide range of operations such as data transfer, operations, comparison, and I/O. The addressing mode using the DE register pair or DL register pair is applied to the MOV and XCH instructions.

This addressing mode, combined with an increment/decrement instruction for a general register or register pair, enables data memory space addresses to be freely updated as shown in Figure 3-3.

Example 1. The data at 50H to 57H is compared with the data at 110H to 117H.

```
DATA1 EQU 57H
DATA2 EQU 117H
      SET1 MBE
      SEL MB1
      MOV D,#DATA1 SHR4
      MOV HL,#DATA2 AND 0FFH
LOOP: MOV A,@DL
      SKE A,@HL ; A = (HL)?
      BR NO ; NO
      DECS L ; YES, L <- L - 1
      BR LOOP
```

Example 2. The data memory of 00H to FFH is cleared to 0.

```
CLR1 RBE
CLR1 MBE
MOV XA,#00H
MOV HL,#04H
LOOP: MOV @HL,A ; (HL) <- A
      INCS HL ; HL <- HL + 1
      BR LOOP
```

Figure 3-3. Updating Static RAM Addresses

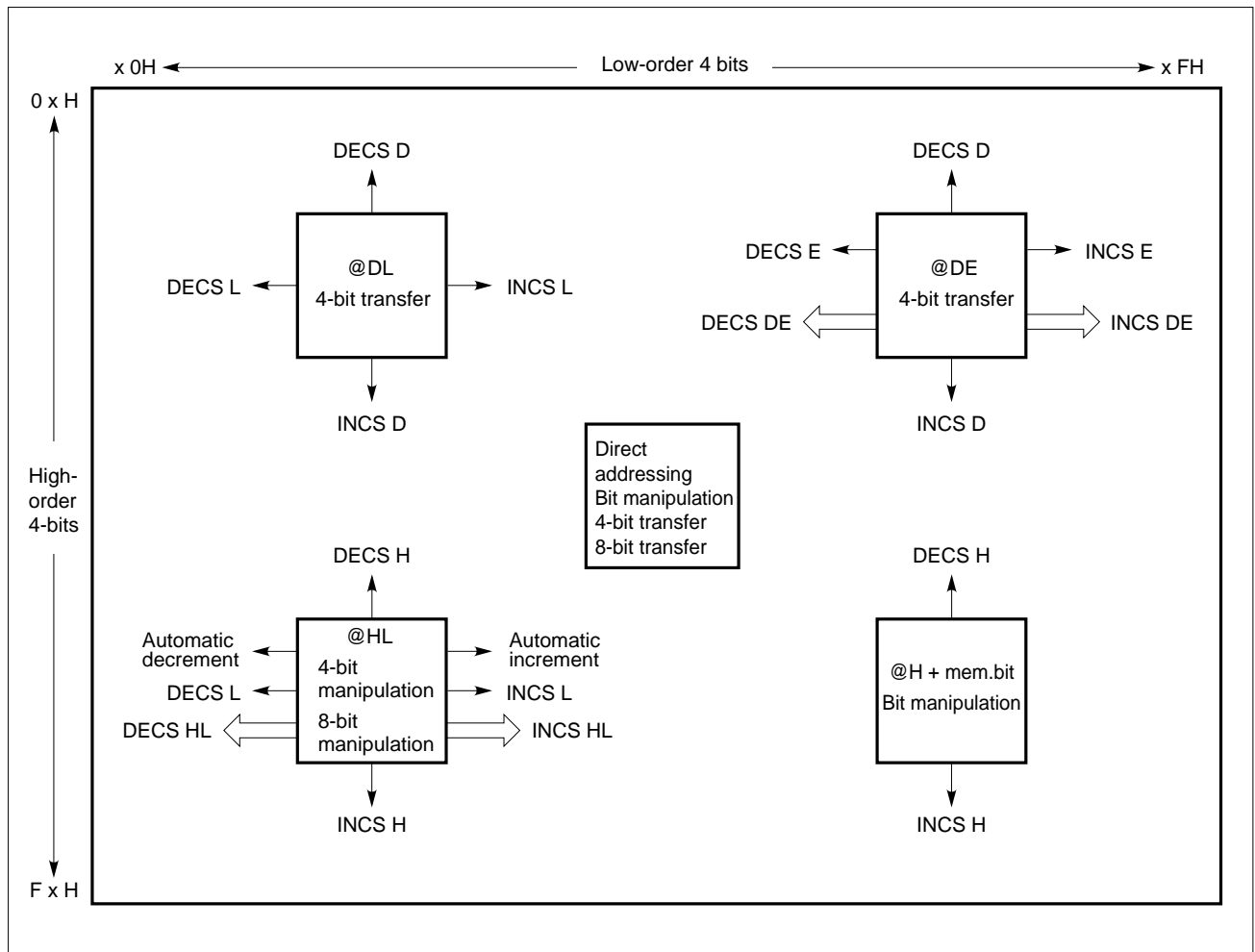

(5) 8-bit register indirect addressing (@HL)

In this addressing mode, the data pointer (HL register pair) indirectly specifies any area in the data memory space in units of eight bits.

The 4-bit data at the address determined with bit 0 of the data pointer (bit 0 of the L register) set to 0 and the 4-bit data at the address incremented by 1 are processed as a pair on an 8-bit basis with the 8-bit accumulator (XA register pair).

A memory bank is specified in the same way as the 4-bit register indirect addressing with the HL register specified. In this case, MB = MBE·MBS.

This addressing mode can be applied to the MOV, XCH, and SKE instructions.

Example 1. A comparison is made to determine whether the value of the count register (T0) of timer/event counter 0 is equal to the data at addresses 30H and 31H.

```
DATA EQU 30H
      CLR1 MBE
      MOV HL,#DATA
      MOV XA,T0 ; XA <- Count register 0
      SKE XA,@HL ; XA = (HL)?
```

Example 2. The data memory of 00H to FFH is cleared to 0.

```
CLR1 RBE
CLR1 MBE
MOV XA,#00H
MOV HL,#04H
LOOP: MOV @HL,XA ; (HL) <- XA
      INCS HL
      INCS HL
      BR LOOP
```

(6) Bit manipulation addressing

This addressing mode is used to perform bit manipulations (such as Boolean operations and bit transfer) for each bit in the data memory space.

The 1-bit direct addressing mode can be applied only to the set, reset, and test instructions. On the other hand, the bit manipulation addressing enables a wide variety of bit manipulations such as Boolean operations using the AND1, OR1, and XOR1 instructions, bit transfers using the MOV1 instruction, and test and reset operations using the SKTCLR instruction.

There are three types of bit manipulation addressing. The user can choose from these options according to the data memory address used.

(a) Specific address bit direct addressing (fmem.bit)

In this addressing mode, peripheral equipment that frequently performs bit manipulations involving, for example, I/O ports and interrupt flags, can be processed at all times regardless of memory bank setting. Accordingly, the data memory addresses that allow this addressing mode to be used are FF0H to FFFH where I/O ports are mapped, and FB0H to FBFH where interrupt-related hardware is mapped. Hardware mapped to these data memory areas can freely perform bit manipulations in the direct addressing mode at any time regardless of MBS and MBE setting.

Example 1. Value input to P02 is inverted, and the result is output on P33.

```
MOV1  CY, PORT0.2
NOT1  CY
MOV1  PORT3.3, CY
```

Example 2. The timer 0 interrupt request flag (IRQ0) is tested. The request flag, if set, is cleared, and P63 is reset.

```
SKTCLR  IRQ0    ; IRQ0 = 1?
BR      NO      ; NO
CLR1    PORT6.3 ; YES
```

Example 3. If both P30 and P41 are set to 1, P53 is reset.

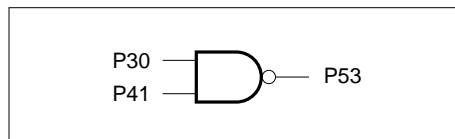

```
MOV1  CY, PORT3.0 ; CY <- P30
AND1  CY, PORT4.1 ; CY ^ P41
NOT1  CY          ; CY <- NOT CY
MOV1  PORT5.3, CY ; P53 <- CY
```

(b) Specific address bit register indirect addressing (pmem.@L)

In this addressing mode, the bits of peripheral hardware I/O ports are indirectly specified using a register to allow continuous manipulations. This addressing mode can be applied to data memory addresses FC0H to FFFH. This range of data memory includes a bit manipulation memory area (see **Section 5.10**) for more effective addressing in this mode, as well as I/O ports.

In this addressing mode, the high-order 10 bits of a 12-bit data memory address is directly specified in the operand, and the low-order two bits and bit address are indirectly specified using the L register. Thus the use of the L register enables 16 bits (four ports) to be continuously manipulated.

This addressing mode again enables bit manipulation regardless of MBE and MBS setting.

Example 1. Pulses are output on the bits in the order from port 4 to port 7.

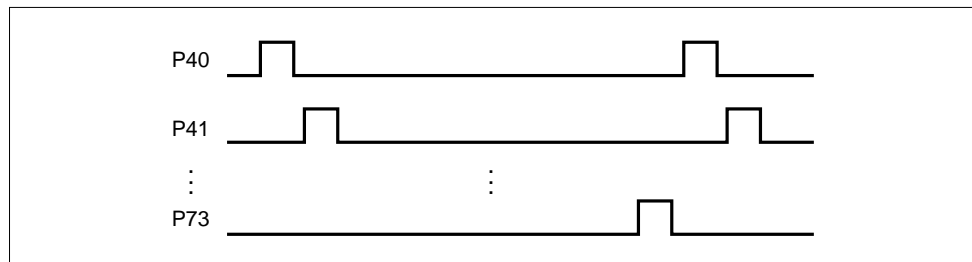

```

MOV    L,#0
LOOP:  SET1  PORT4.@L ; Bits (L1-0) of ports 4 to 7 <- 1
        CLR1  PORT4.@L ; Bits (L1-0) of ports 4 to 7 <- 0
        INCS  L
        BR    LOOP
    
```

Example 2. When P30 is high, the 16-bit serial data applied to P31 is transferred to the bit sequential buffer (BSB).

```

MOV    L,#0
LOOP:  SKT   PORT3.0    ; P30 = 1?
        BR   LOOP
        MOV1  CY,PORT3.1 ; CY <- P31
        MOV1  BSB0.@L,CY ; BSB BIT (L1-0) <- CY
WAIT:  SKF   PORT3.0    ; P30 = 0?
        BR   WAIT
        INCS  L          ; L <- L + 1
        BR   LOOP
    
```

(c) Specific 1-bit direct addressing (@H+mem.bit)

This addressing mode enables any bit in the data memory space to be manipulated.

In this addressing mode, the high-order four bits of the data memory address in the memory bank specified by MB = MBE-MBS are indirectly specified using the H register, and the low-order four bits and bit address are directly specified in the operand. This addressing mode enables a wide variety of manipulations for each bit in the entire data memory space.

Example Bit 2 at address 32H (FLAG3) is reset if both bit 3 at address 30H (FLAG1) and bit 0 at address 31H (FLAG2) are set to 0 or 1.

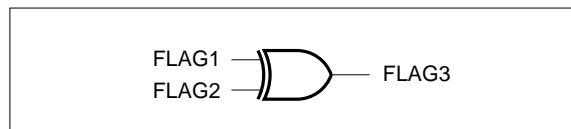

```

FLAG1 EQU 30H.3
FLAG2 EQU 31H.0
FLAG3 EQU 32H.2
      SEL MB0
      MOV H,#FLAG1 SHR 6
      MOV1 CY, @H+FLAG1 ; CY <- FLAG1
      XOR1 CY, @H+FLAG2 ; CY <- CY XOR FLAG2
      MOV1 @H+FLAG3, CY ; FLAG3 <- CY
  
```

(7) Stack addressing

This addressing mode is used for save/restoration operation in interrupt processing or subroutine processing.

In this addressing mode, the address indicated by the stack pointer (SP) of data memory bank 0, 1, 2, or 3 that is selected by the stack bank select register (SBS) is specified.

This addressing mode can be used for register save/restoration operation using the PUSH or POP instruction as well as save/restoration operation in interrupt and subroutine processing.

Example 1. A register is saved and restored in subroutine processing.

```
SUB   PUSH   XA
      PUSH   HL
      PUSH   BS   ; Save MBS and RBS
      :
      POP    BS
      POP    HL
      POP    XA
      RET
```

Example 2. The contents of the HL register pair are transferred to the DE register pair.

```
PUSH   HL
POP    DE   ; DE <- HL
```

Example 3. A branch is made to the address indicated by the [XABC] register.

```
PUSH   BC
PUSH   XA
RET                    ; Branch to address XABC
```

3.2 General Register Bank Configuration

The μ PD75518 contains four register banks, each consisting of eight general registers: X, A, B, C, D, E, H, and L. These registers are mapped to addresses 00H to 1FH in memory bank 0 of the data memory (**Figure 3-2**). To specify a general register bank, a register bank enable flag (RBE) and a register bank select register (RBS) are contained. The RBS is a register used to select a register bank, and the RBE is a flag used to determine whether a register bank selected using the RBS is to be enabled.

The register bank (RB) enabled at instruction execution is determined as

$$RB = RBE \cdot RBS$$

Table 3-2. Register Bank to Be Selected with the RBE and RBS

RBE	RBS				Register bank
	3	2	1	0	
0	0	0	x	x	Bank 0 is always selected.
1	0	0	0	0	Bank 0 is selected.
			0	1	Bank 1 is selected.
			1	0	Bank 2 is selected.
			1	1	Bank 3 is selected.

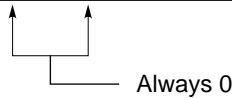

x: Don't care

The contents of the RBE are automatically saved or restored at the beginning or end of subroutine processing, so that the RBE can be freely modified during subroutine processing. In interrupt processing, the RBE is automatically saved or restored, and when interrupt processing is started, the contents of the RBE can be specified for the interrupt processing by setting the interrupt vector table. Therefore, as indicated in Table 3-3, by selecting a register bank depending on whether the processing is normal or interrupt, the general register need not be saved and restored for the level-one interrupt processing, and only the RBS needs to be saved and restored for the level-two interrupt processing, thus speeding up interrupt processing.

Table 3-3. Recommended Use of Register Banks with Normal Routines and Interrupt Routines

Normal processing	Use register banks 2 and 3 with RBE = 1.
Level-one interrupt processing	Use register bank 0 with RBE = 0.
Level-two interrupt processing	Use register bank 1 with RBE = 1. (In this case, the RBS needs to be saved and restored.)
Multiple (triple or more) interrupt processing	Save and restore the registers with PUSH or POP.

Figure 3-4. Example of Register Bank Selection

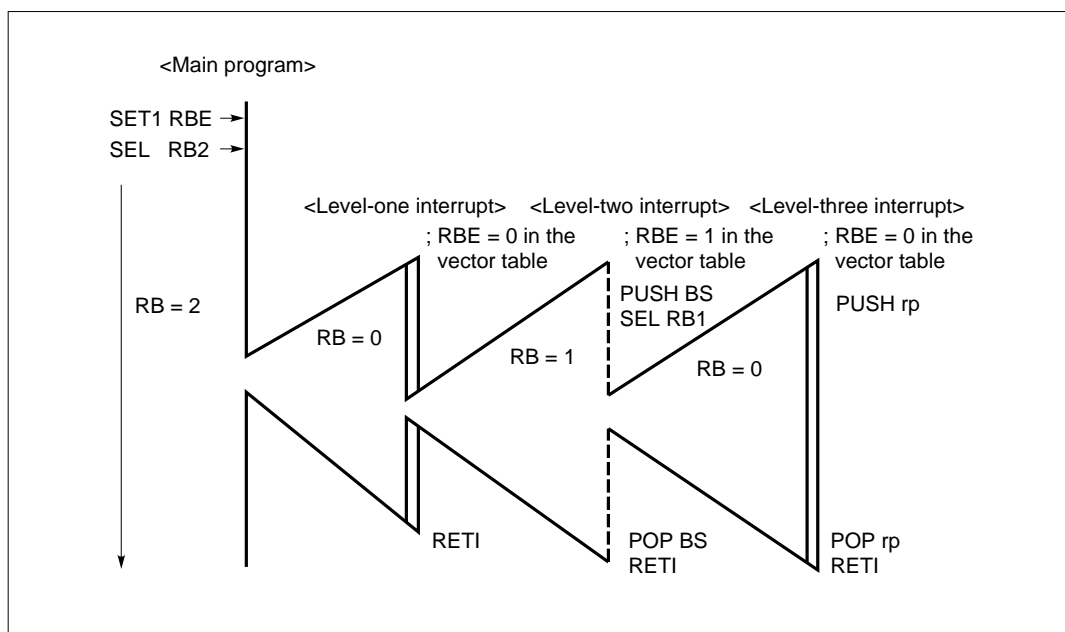

Remark ————— RB = 2, = = = = RB = 0, - - - - - RB = 1

The setting of the RBS can be modified for subroutine processing or interrupt processing by saving or restoring the RBS with the PUSH or POP instruction.

The RBE is set using the SET1 or CLR1 instruction. The RBS is set using the SEL instruction.

Example

```

SET1  RBE   ; RBE <- 1
CLR1  RBE   ; RBE <- 0
SEL   RB0   ; RBS <- 0
SEL   RB3   ; RBS <- 3
    
```

The general register area of the μ PD75518 can be used not only on a 4-bit basis, but also on an 8-bit basis with register pairs. This enables users to perform transfers, arithmetic/logical operations, comparisons, and increments and decrements at a speed comparable to that of an 8-bit microcomputer, and thereby enables to program using mainly general registers.

(1) When used as a 4-bit register

When the general register area is used on a 4-bit basis, eight general registers, the X, A, B, C, D, E, H, and L registers, are available in the register bank specified with RB = RBE·RBS as shown in Figure 3-4. The A register functions as a 4-bit accumulator which performs transfers, arithmetic/logical operations, and comparisons. The other general registers perform transfers, comparisons, and increments/decrements with the accumulator.

(2) When used as an 8-bit register

When the general register area is used on an 8-bit basis, the register pairs in the register bank specified by RBE-RBS can be specified as XA, BC, DE, and HL as shown in Figure 3-5, and the register pairs in the register bank that has the inverted value of bit 0 of the register bank (RB) can be specified as XA', BC', DE', and HL', thus providing up to eight 8-bit registers. The XA register pair functions as an 8-bit accumulator which performs transfers, arithmetic/logical operations, comparisons, and increments/ decrements of 8-bit data. The other register pairs perform transfers, arithmetic/logical operations, comparisons, and increments/decrements with the accumulator. The HL register pair functions mainly as a data pointer, and the DE register pair functions as an auxiliary data pointer.

Example 1.

```

INCS    HL           ; HL <- HL + 1, skip at HL = 00H
ADDS    XA,BC       ; ;XA <- XA + BC, skip at carry
SUBC    DE',XA      ; DE' <- DE' - XA - CY
MOV     XA,XA'      ; XA <- XA'
MOVT    XA,@PCDE    ; XA <- (PC12-8 + DE) ROM, reference table
SKE     XA, BC      ; Skip if XA = BC
    
```

Example 2. The value of the count register (T0) for timer/event counter 0 is tested until it becomes greater than the value of the BC' register pair.

```

CLR1    MBE
NO:     MOV     XA,T0    ; Read count register
        SUBS    XA,BC'   ; XA ≥ BC?
        BR     YES     ; YES
        BR     NO     ; NO
    
```

Figure 3-5. General Register Configuration (4-bit Processing)

X	01H	A	00H	Register bank 0 (RBE·RBS = 0)
H	03H	L	02H	
D	05H	E	04H	
B	07H	C	06H	
X	09H	A	08H	Register bank 1 (RBE·RBS = 1)
H	0BH	L	0AH	
D	0DH	E	0CH	
B	0FH	C	0EH	
X	11H	A	10H	Register bank 2 (RBE·RBS = 2)
H	13H	L	12H	
D	15H	E	14H	
B	17H	C	16H	
X	19H	A	18H	Register bank 3 (RBE·RBS = 3)
H	1BH	L	1AH	
D	1DH	E	1CH	
B	1FH	C	1EH	

Figure 3-6. General Register Configuration (8-bit Processing)

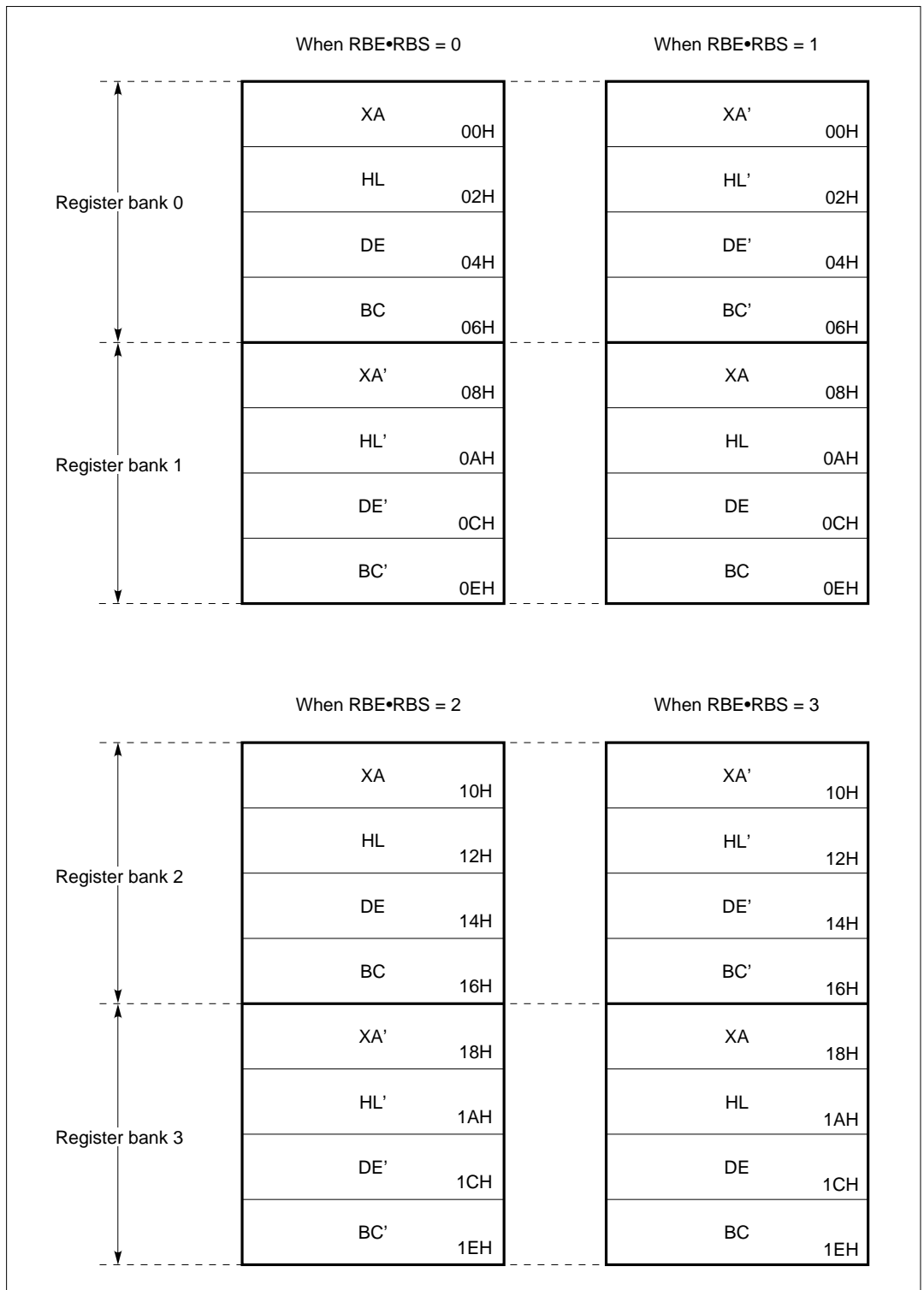

3.3 Memory-mapped I/O

The μ PD75518 employs memory-mapped I/O, which maps peripheral hardware such as timers and I/O ports to addresses F80H to FFFH in data memory space as shown in Figure 3-7. This means that there is no particular instruction to control peripheral hardware, but all peripheral hardware is controlled using memory manipulation instructions. (Some mnemonics for hardware control are available to make programs readable.)

To manipulate peripheral hardware, the addressing modes listed in Table 3-4 can be used.

Table 3-4. Addressing Modes Applicable to Peripheral Hardware Operation

	Applicable addressing mode	Applicable hardware
Bit manipulation	Direct addressing mode specifying mem.bit with MBE = 0 (MBE = 1, MBS = 15)	All hardware allowing bit manipulation
	Direct addressing mode specifying fmem.bit regardless of MBE and MBS setting	IST0, IST1, MBE, RBE, EOT, IE _{xxx} , IRQ _{xxx} , PORT _{n.x}
	Indirect addressing mode specifying pmem.@L regardless of MBE and MBS setting	BSB _{n.x} PORT _{n.x}
4-bit manipulation	Direct addressing mode specifying mem with MBE = 0 or (MBE = 1, MBS = 15)	All hardware allowing 4-bit manipulation
	Register indirect addressing mode specifying @HL with (MBE = 1, MBS = 15)	
8-bit manipulation	Direct addressing mode specifying mem (even address) with MBE = 0 or (MBE = 1, MBS = 15)	All hardware allowing 8-bit manipulation
	Register indirect addressing mode specifying @HL (with the L register containing an even number) with MBE = 1 and MBS = 15	

Figure 3-7 summarizes the I/O map of the μ PD75518.

The items in the figure have the following meanings:

- Symbol : Name representing incorporated hardware, which can be coded in the operand field of an instruction
- R/W : Indicates whether the hardware allows read/write operation.
 - R/W : Both read and write operations possible
 - R : Read only
 - W : Write only
- Number of manipulatable bits:
 - Indicates the number of bits that can be processed at a time in hardware manipulation
 - : Bit manipulation is possible in units of the indicated number of bits (1, 4, or 8 bits).
 - △ : Particular bits can be manipulated. For these bits, see Remarks.
 - : Bit manipulation is impossible in units of the indicated number of bits (1, 4, or 8 bits).
- Bit manipulation addressing:
 - Bit manipulation addressing applicable in hardware bit manipulation

Figure 3-7. μ PD75518 I/O Map (1/4)

Address	Hardware name (symbol)				R/W	Number of bits that can be manipulated			Bit manipulation addressing	Remarks
	b3	b2	b1	b0		1 bit	4 bits	8 bits		
F80H	Stack pointer (SP)				R/W	-	-	○		Bit 0 is always 0.
						-	-			
F82H	Register bank select register (RBS)	Bank select register (BS)			R	-	○	○		(Note 1)
F83H	Memory bank select register (MBS)					-	○			
F84H	Stack bank select register (SBS)				R/W	-	○	-		Bits 3 and 2 are always set to 0.
F85H	Basic interval timer mode register (BTM)				W	△	○	-	mem.bit	Only bit 3 can be manipulated.
F86H	Basic interval timer (BT)				R	-	-	○		
F90H	Timer pulse generator (TPGM)				W	△	-	○	mem.bit	Only bit 3 can be manipulated.
						-	-			
F94H	Timer/pulse generator modulo register (MODL)				R/W	-	-	○		
F96H	Timer/pulse generator modulo register (MODH)				R/W	-	-	○		
F98H	Clock mode register (WM)				-	-	-	○		
					W	-	-			
FA0H	Timer/event counter 0 mode register (TM0)				W	△	-	○	mem.bit	Only bit 3 can be manipulated.
						-	-			
FA2H	TOE0 ^(Note 2)				W	○	-	-	mem.bit	
FA4H	Timer/event counter 0 count register (T0)				R	-	-	○		
FA6H	Timer/event counter 0 modulo register (TMOD0)				W	-	-	○		

(Note 1) In 4-bit manipulation, RBS and MBS can be manipulated separately.
In 8-bit manipulation, these two locations can be manipulated at a time with BS specified.

(Note 2) TOE0: Output enable flag (W) of timer/event counter 0

Figure 3-7. μ PD75518 I/O Map (2/4)

Address	Hardware name (symbol)				R/W	Number of bits that can be manipulated			Bit manipulation addressing	Remarks
	b3	b2	b1	b0		1 bit	4 bits	8 bits		
FB0H	IST1	IST0	MBE	RBE	R/W	○	○	○	fmem.bit	
	Program status word (PSW)				R	-	-			
FB2H	Interrupt priority select register (IPS)				W	-	○	-	fmem.bit	Manipulated with EI/DI instruction
FB3H	Processor clock control register (PCC)				W	-	○	-		
FB4H	INT0 mode register (IM0)				W	-	○	-		Bit 2 is always 0
FB5H	INT1 mode resistor (IM1)				W	-	○	-	fmem.bit	Bits 3, 2, and 1 are always 0
FB6H	INT2 mode register (IM2)				W	-	○	-		Bits 3 and 2 are always 0
FB7H	System clock control register (SCC)				W	○	-	-		Bits 2 and 1 are always 0
FB8H	IE4	IRQ4	IEBT	IRQBT	R/W	○	○	-	fmem.bit	
FB9H	/	/	/	EOT	R/W	○	○	-		
FBAH	/	/	IEW	IRQW	R/W	○	○	-		
FBBH	/	/	IETPG	IRQTPG	R/W	○	-	-		
FBCH	/	/	IET0	IRQT0	R/W	○	○	-		
FBDH	/	/	IECSI0	IRQCSI0	R/W	○	○	-		
FBEH	IE1	IRQ1	IE0	IRQ0	R/W	○	○	-		
FBFH	/	/	IE2	IRQ2	R/W	○	○	-		
FC0H	Bit sequential buffer 0 (BSB0)				R/W	○	○	○	mem.bit pmem.@L	
FC1H	Bit sequential buffer 1 (BSB1)				R/W	○	○	○		
FC2H	Bit sequential buffer 2 (BSB2)				R/W	○	○	○		
FC3H	Bit sequential buffer 3 (BSB3)				R/W	○	○	○		
FC8H	Serial operation mode register 1 (CSIM1)				W	-	-	○	mem.bit	Only bit 7 can be manipulated.
	CSIE1					△	-	○		
FCCH	Serial I/O shift register 1 (SIO0)				R/W	-	-	○		

- Remarks
1. IExxx is an interrupt enable flag.
 2. ERQxxx is an interrupt request flag.

Figure 3-7. μ PD75518 I/O Map (3/4)

Address	Hardware name (symbol)				R/W	Number of bits that can be manipulated			Bit manipulation addressing	Remarks
	b3	b2	b1	b0		1 bit	4 bits	8 bits		
FD0H	Clock output mode register (CLOM)				W	-	○	-		
FD8H	SOC	EOC	ADM1		W	△	-	○		b3: 1-bit write b2: 1-bit read
	A/D conversion mode register (ADM)					-	-			
FDAH	SA register (SA)				R	-	-	○		
						-	-			
FDCH	Pull-up resistor specification register group A (POGA)				W	-	-	○		
FE0H	Serial operation mode register 0 (CSIM0)				W	-	-	○		
	CSIE0	COI	WUP		R/W	○	○	○	mem.bit	b6: 1-bit read
FE2H	CMDD	RELD	CMDT	RELT	R/W	○	-	-	mem.bit	All bits allow bit manipulation only
	SBI control register (SBIC)					○	-	-		
	BSYE	ACKD	ACKE	ACKT						
FE4H	Serial I/O shift register 0 (SIO0)				R/W	-	-	○		
FE6H	Slave address register (SVA)				W	-	-	○		
FE8H	PM33	PM32	PM31	PM30	W	-	-	○		
	Port mode register group A (PMGA)					-	-	○		
	PM63	PM62	PM61	PM60						
FECH	-	PM2	-	-	W	-	-	○		
	Port mode register group B (PMGB)					-	-	○		
	PM7	-	PM5	PM4	W	-	-	○		
FEEH	PM11	PM10	PM9	- (Note)		-	-	○		
	Port mode register group C (PMGC)									
	- (Note)	PM14	PM13	PM12						

(Note) In program development, the following bits in port mode register group C (PMGC) must be set to 0:
 FEEH, b0 (corresponding to PM8)
 FEFH, b3 (corresponding to PM15)
 This is because I/O ports are specified on the emulator, while on the μ PD75518, input ports are specified.

Figure 3-7. μ PD75518 I/O Map (4/4)

Address	Hardware name (symbol)				R/W	Number of bits that can be manipulated			Bit manipulation addressing	Remarks
	b3	b2	b1	b0		1 bit	4 bits	8 bits		
FF0H	Port 0 (PORT0)				R	○	○	-	fmem.bit pmem.@L	
FF1H	Port 1 (PORT1)				R	○	○			
FF2H	Port 2 (PORT2)				R/W	○	○	-		
FF3H	Port 3 (PORT3)				R/W	○	○			
FF4H	Port 4 (PORT4)				R/W	○	○	○		
FF5H	Port 5 (PORT5)				R/W	○	○			
FF6H ^(Note)	KR3	KR2	KR1	KR0	R/W	○	○	○		
	Port 6 (PORT6)									
FF7H ^(Note)	KR7	KR6	KR5	KR4	R/W	○	○	○		
	Port 7 (PORT7)									
FF8H	Port 8 (PORT8)				R	○	○	-		
FF9H	Port 9 (PORT9)				R/W	○	○			
FFAH	Port 10 (PORT10)				R/W	○	○	-		
FFBH	Port 11 (PORT11)				R/W	○	○			
FFCH	Port 12 (PORT12)				R/W	○	○	-		
FFDH	Port 13 (PORT13)				R/W	○	○			
FFEH	Port 14 (PORT14)				R/W	○	○	-		
FFFH	Port 15 (PORT15)				R	○	○			

(Note) KR0 to KR7 are read-only. In 4-bit parallel input processing, PORT6 or PORT7 is specified.

[MEMO]

Chapter 4

Internal CPU Functions

4.1 Program Counter (PC): 15 Bits

The program counter is a 15-bit binary counter for holding program memory address information.

Figure 4-1. Program Counter Format

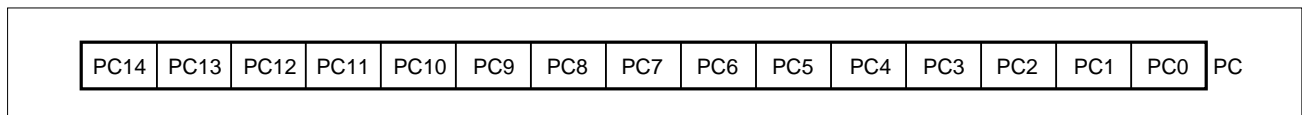

Usually, each time an instruction is executed, the program counter is automatically incremented according to the number of bytes in the instruction.

Note that the reset start address must be set within a space of 16K bytes (0000H to 3FFFH) because a $\overline{\text{RESET}}$ signal initializes program memory contents as follows:

PC13-PC8 <- low order six bits of address 0000H

PC7-PC0 <- contents of address 0001H

PC14 <- 0

- When a branch instruction (BR, BRA, BRCB) is executed, immediate data indicating the branch destination and the contents of a register pair are set in all or some bits of the program counter.
- When a subroutine call instruction (CALL, CALLA, CALLF) is executed, or a vectored interrupt occurs, the current contents of the program counter (already incremented return address for fetching the next instruction) are saved in the stack memory (data memory indicated by the stack pointer), then the jump destination address is loaded.
- When a return instruction (RET, RETS, RETI) is executed, the contents of the stack memory are set in the program counter.

4.2 Program Memory (ROM):

24448 x 8 Bits (μ PD75517)

32640 x 8 Bits (μ PD75518 and μ PD75P518)

As the program memory, the μ PD75517 is provided with a mask ROM of 24448 x 8 bits, the μ PD75518 with a mask ROM of 32640 x 8 bits, and the μ PD75P518 with a PROM of 32640 x 8 bits. The program memory is used for storing programs, an interrupt vector table, GETI instruction reference table, table data, and so forth.

Figures 4-2 and 4-3 show the program memory maps.

Program memory is addressed by the program counter. Table data can be referenced using the table reference instruction (MOV_T).

Figures 4-2 and 4-3 also show the allowable branch address ranges for the branch instructions and subroutine call instructions. The BRA !addr1 and the CALLA !addr1 instructions allow a direct branch throughout the whole space. The BR \$addr instruction allows a branch to addresses (contents of the PC less 15 to one, or plus two to 16) regardless of block boundaries.

The program memory is located at addresses 0000H to 5F7FH for the μ PD75517, or 0000H to 7F7FH for the μ PD75518 and μ PD75P518. The following addresses are assigned to special functions. All areas excluding 0000H and 0001H can be used as normal program memory.

- 0000H to 0001H

Vector address table for holding the MBE and RBE setting values and program start address at the time of a reset allowing a reset start at an arbitrary address within a 16K-byte space (0000H to 3FFFH)

- 0002H to 000DH

Vector address table for holding the MBE and RBE setting values and program start address for each vectored interrupt allowing interrupt processing to be started at an arbitrary address within a 16K-byte space (0000H to 3FFFH)

- 0020H to 007FH

Table area referenced by the GETI instruction(**Note**)

(Note) The GETI instruction can represent an arbitrary 2-byte or 3-byte instruction or two 1-byte instructions in 1 byte, thus reducing the number of program bytes.

Figure 4-2. Program Memory Map (μ PD75517)

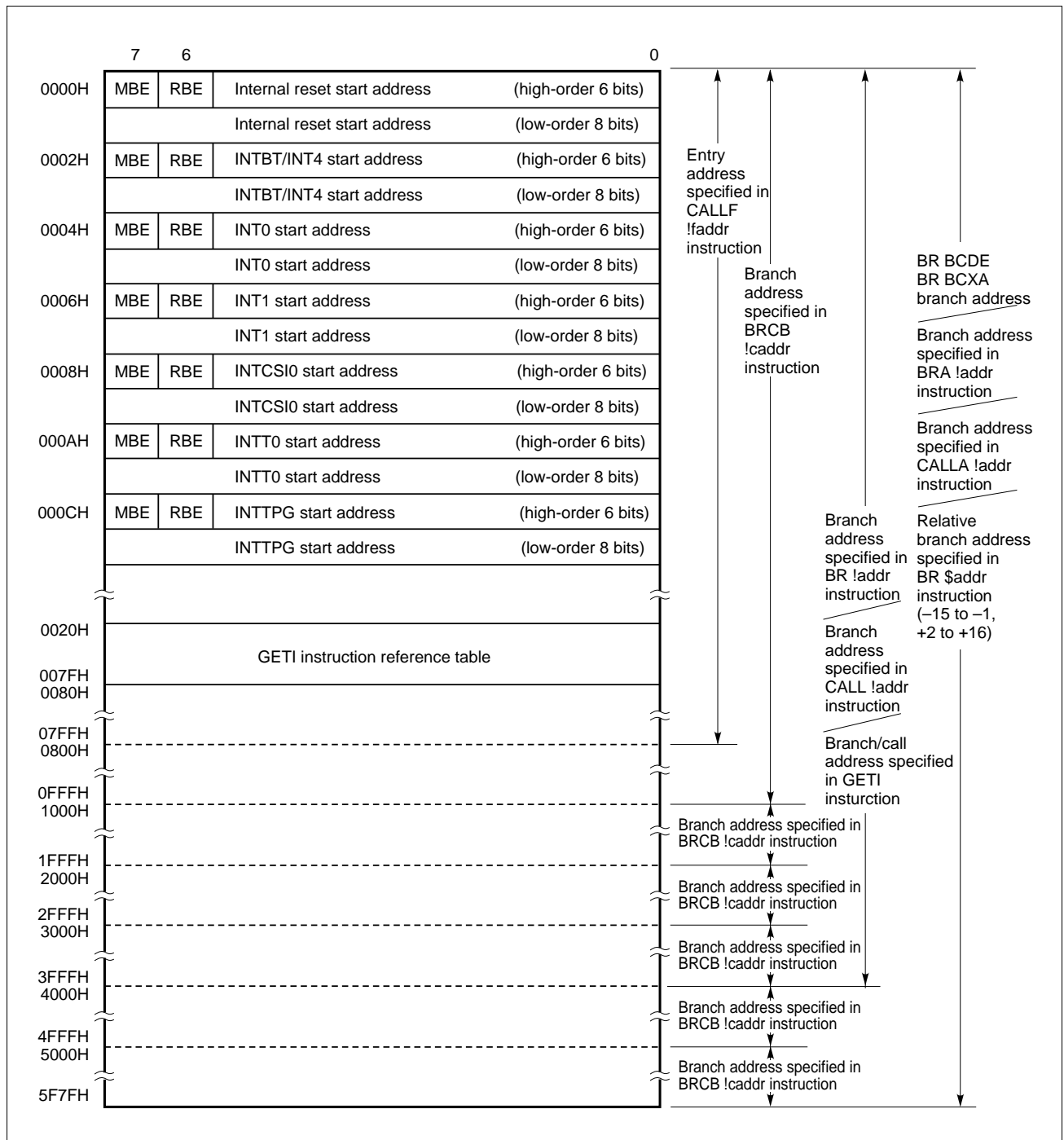

Caution The start address of an interrupt vector shown in Figure 4-2 consists of 14 bits. So, the start address must be set within a 16K-byte space (0000H to 3FFFH).

Remark Although not listed in Figure 4-2, the BR PCDE and BR PCXA instructions can cause a branch to an address with only the low-order 8 bits of the PC changed.

Figure 4-3. Program Memory Map (μ PD75518 and μ PD75P518)

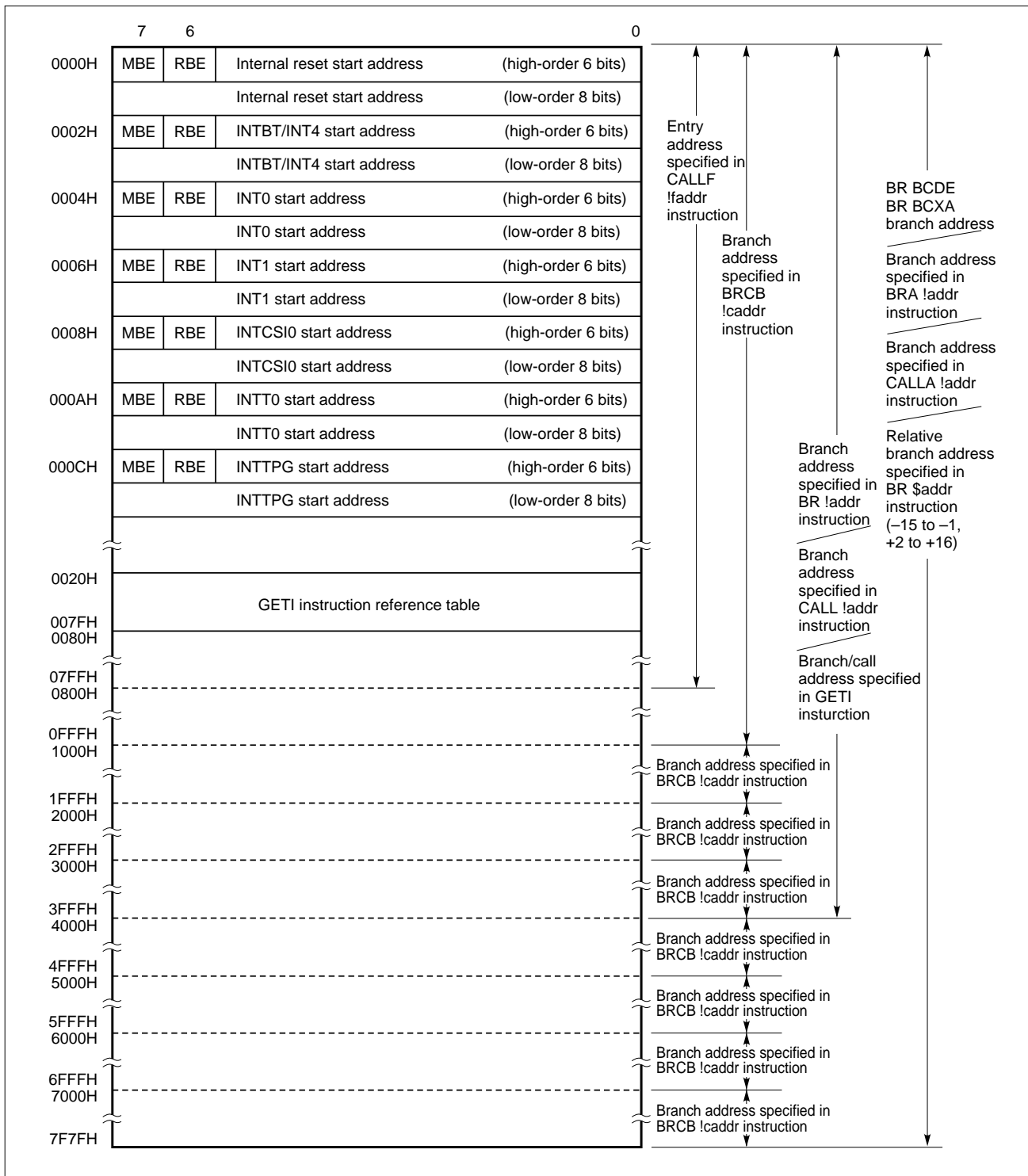

Caution The start address of an interrupt vector shown in Figure 4-3 consists of 14 bits. So, the start address must be set within a 16K-byte space (0000H to 3FFFH).

Remark Although not listed in Figure 4-3, the BR PCDE and BR PCXA instructions can cause a branch to an address with only the low-order 8 bits of the PC changed.

4.3 Data Memory (RAM): 1024 Words x 4 Bits

The data memory consists of a data area and peripheral hardware area as shown in Figure 4-4.

The data memory consists of the following memory banks with each bank made of 256 words x 4 bits.

- Memory banks 0, 1, 2, and 3 (data area)
- Memory bank 15 (peripheral hardware area)

4.3.1 Data Memory Configuration

Figure 4-4. Data Memory Map

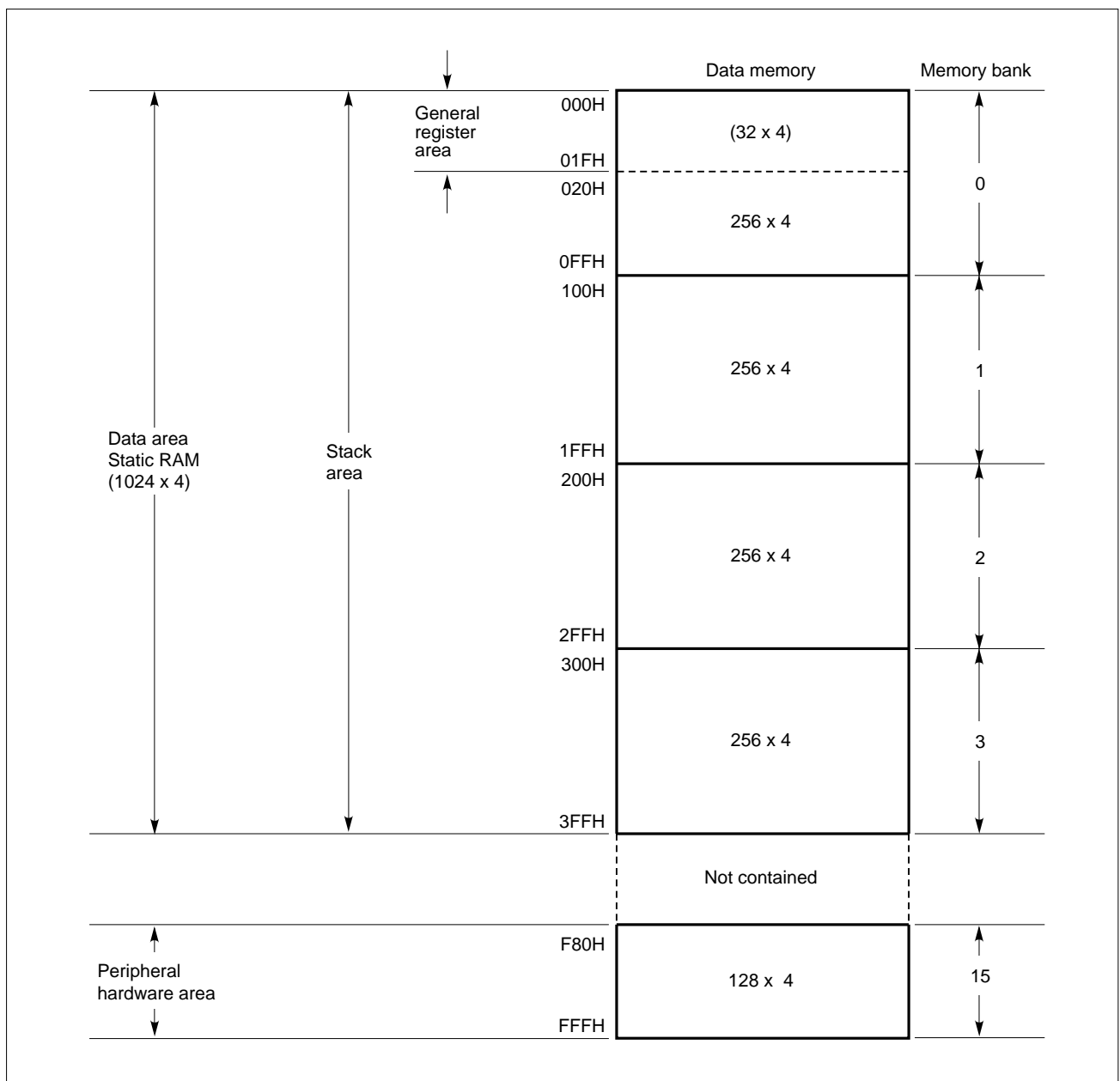

(1) Data area

The data area consists of a static RAM, and is used for storing data and as stack memory for subroutine and interrupt execution. Battery backup enables the memory to hold data for a long time even if the CPU is stopped in the standby mode. The data area can be manipulated with memory manipulation instructions.

The static RAM is mapped to memory banks 0, 1, 2, and 3, with each made up of 256 x 4 bits. Bank 0 is used as a data area, but can also be used as a general register area (000H to 01FH).

Whole locations in memory banks 0, 1, 2, and 3 (000H to 3FFH) can be used as a stack area.

The static RAM has a configuration of four bits per address. However, the memory can be manipulated in 8 bit units using an 8-bit memory manipulation instruction, and in bit units using a bit manipulation instruction. Note that an even address must be specified in an 8-bit manipulation instruction.

(a) General register area

The general register area can be manipulated with either general register manipulation instructions or memory manipulation instructions. Up to 32 4-bit registers are available. Of the 32 general registers, registers not used by the program can be used as a data area or stack area.

(b) Stack memory area

The stack area can be allocated within a bank with the stack pointer (SP). The bank for the stack area is selected from the memory banks 0, 1, 2, and 3 with the stack bank select register (SBS). Stack area can be used as a save area for subroutine or interrupt execution.

Use memory manipulation instructions to manipulate the stack bank select register (SBS) and the stack pointer (SP).

(2) Peripheral hardware area

The peripheral hardware area is mapped at addresses F80H to FFFH of memory bank 15.

Memory manipulation instructions are used to manipulate the peripheral hardware area as well as the static RAM area. Note that, however, the number of bits to be manipulated at a time varies according to the individual addresses. Addresses to which no peripheral hardware is assigned cannot be accessed since such address locations contain no data memory.

4.3.2 Specification of a Data Memory Bank

If the memory bank enable flag (MBE) enables bank specification (MBE = 1), a memory bank is specified with the 4-bit memory bank select register (MBS = 0, 1, 2, 3, 15). If the MBE disables bank specification (MBE = 0), memory bank 0 or 15 is automatically selected according to the addressing mode. Locations in a bank is addressed by 8-bit immediate data or a register pair.

For details on the selection of a memory bank and addressing, see **Section 3.1**.

For how to use the particular data memory areas, see the following sections and chapter.

- General register area : **Section 4.4**
- Stack memory area : **Section 4.6**
- Peripheral hardware area : **Chapter 5**

4.4 General Register: 8 x 4 Bits x 4 Banks

The general registers are mapped to particular addresses in data memory. Four banks of registers are provided, with each bank consisting of eight 4-bit registers (B, C, D, E, H, L, X, and A).

The register bank (RB) to be enabled at the time of instruction execution is determined by:

$RB = RBE \cdot RBS$: (RBS = 0 to 3)

Each general register allows 4-bit manipulation. In addition, BC, DE, HL, or XA serves as a register pair for 8-bit manipulation. DL also makes a register pair as well as DE and HL. These three register pairs can be used as data pointers.

In 8-bit manipulation, the register pairs in the register banks (0 \leftrightarrow 1, 2 \leftrightarrow 3) that have the inverted value of bit 0 of the register bank (RB) address can be specified as BC', DE', HL', and XA' in addition to the register pairs BC, DE, HL, and XA. (See **Section 3.2.**)

A general register area can be addressed and accessed as normal RAM, regardless of whether it is used as a register.

Figure 4-5. General Register Format

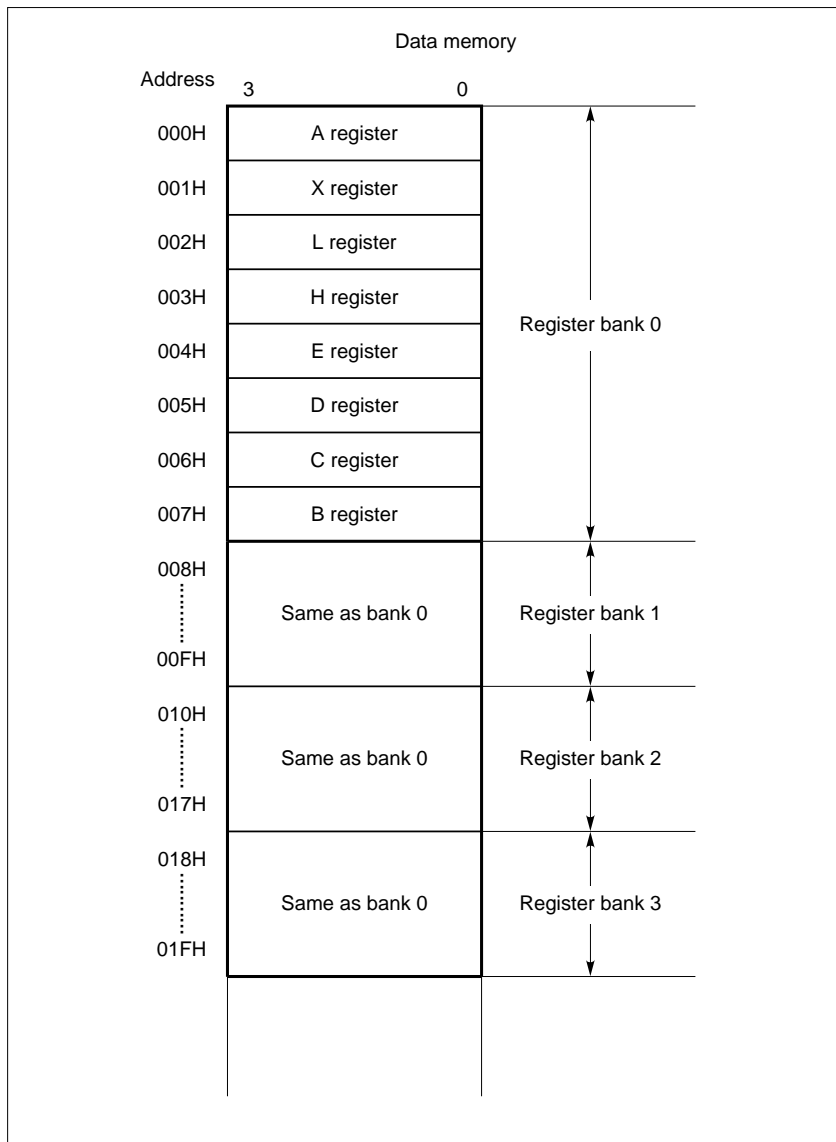
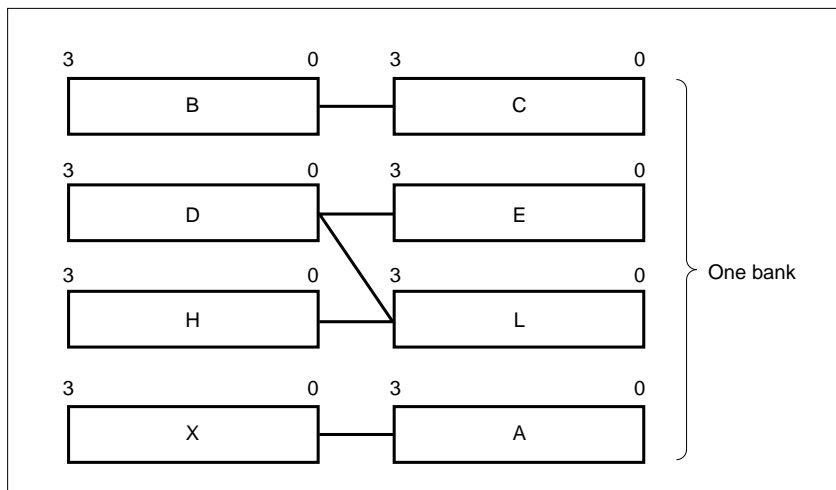

Figure 4-6. Register Pair Format



4.5 Accumulator

In the μ PD75518, the A register and XA register pair function as accumulators. The A register is mainly used for 4-bit data processing instructions, and the XA register pair is mainly used for 8-bit data processing instructions.

For a bit manipulation instruction, the carry flag (CY) functions as a bit accumulator.

Figure 4-7. Accumulator

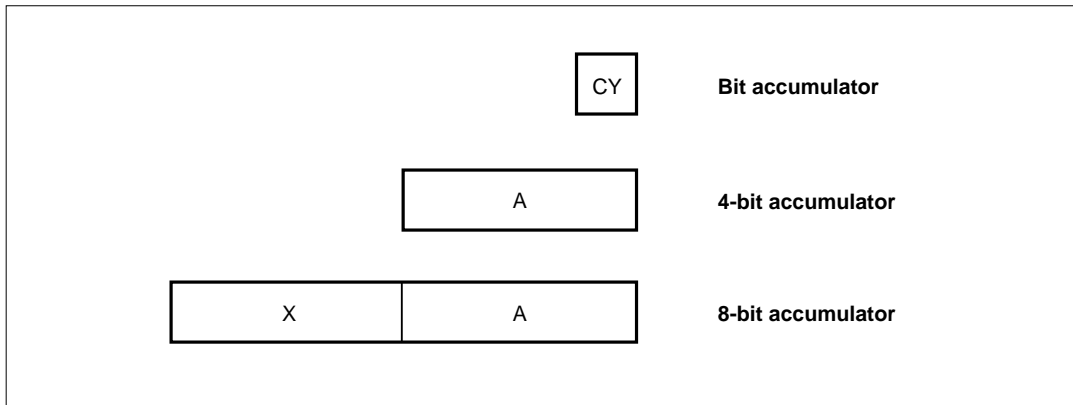

4.6 Stack Pointer (SP) and Stack Bank Select Register (SBS)

The μ PD75518 uses static RAM as stack memory (LIFO scheme), and the 8-bit register holding the start address of the stack area is the stack pointer (SP).

The stack area of the μ PD75518 is located at addresses 000H to 3FFH in memory banks 0 to 3. One of memory banks 0 to 3 is selected according to the value of the 4-bit stack bank select register (SBS). (See **Table 4-1**.)

Table 4-1. Stack Area to Be Selected by the Stack Bank Select Register

SBS		Stack area
SBS1	SBS0	
0	0	Memory bank 0
0	1	Memory bank 1
1	0	Memory bank 2
1	1	Memory bank 3

The SP is decremented before a write (save) operation to stack memory, and is incremented after a read (restoration) operation from stack memory.

The SBS is set by a 4-bit memory manipulation instruction. Note that the high-order two bits (SBS3 and SBS2) are always set to 00.

Figures 4-9 and 4-10 show data saved to and restored from stack memory in these stack operations.

To place the stack area at a given location, the SP can be initialized with an 8-bit memory manipulation instruction, and the SBS can be initialized with a 4-bit memory manipulation instruction. Both can be read from as well.

When the SP is initialized to 00H, a stack operation starts at the high-order address (nFFH) of memory bank (n) specified with the SBS.

A stack area must be within the memory bank specified with the SBS. If a stack operation exceeds address n00H, the operation returns to address nFFH in the same bank. Linear stacking beyond memory bank boundaries is enabled only by resetting the SBS.

A $\overline{\text{RESET}}$ signal causes the contents of the SP and SBS to be undefined. Remember to initialize the SP and SBS to a desired value at the start of a program.

Figure 4-8. Format of Stack Pointer and Stack Bank Select Register

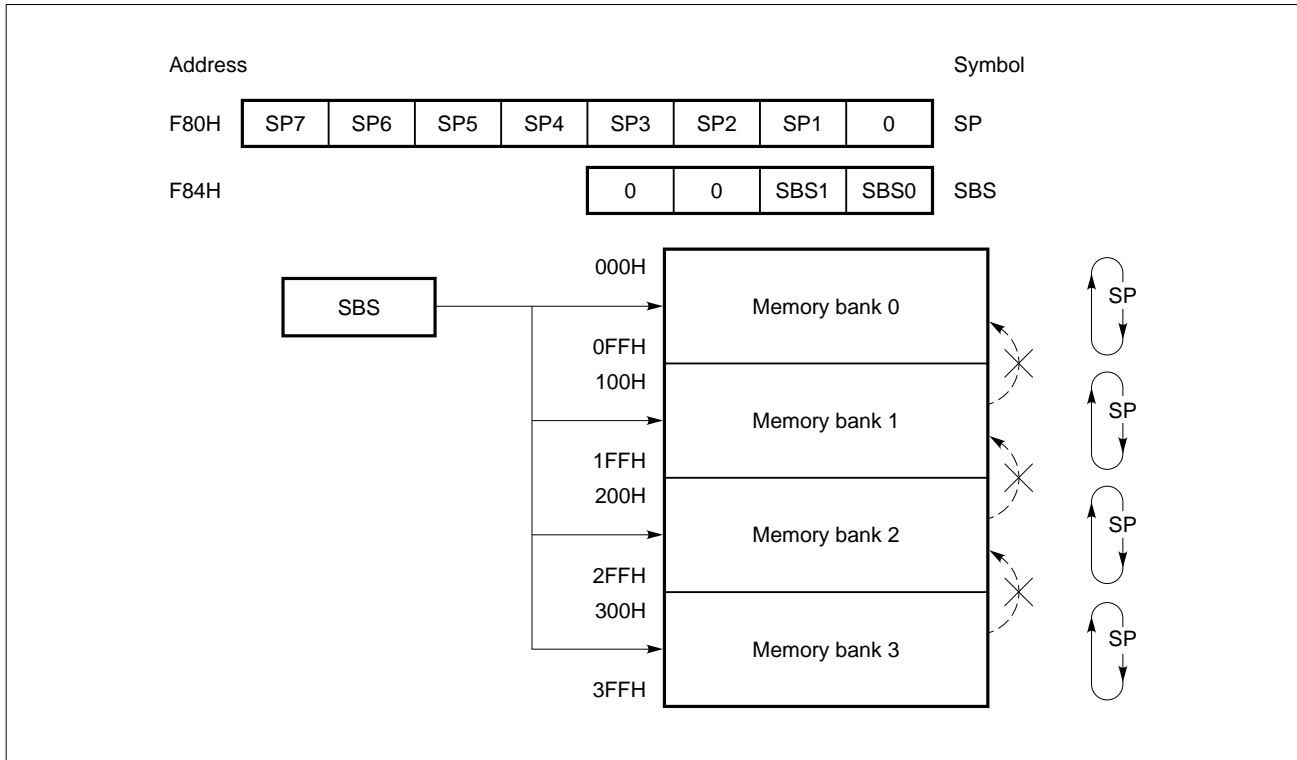

Example SP initialization

Specify memory bank 2 as a stack area to start stack operation at address 2FFH.

```
SEL MB15 ; or CLR1 MBE
```

```
MOV A,#2
```

```
MOV SBS,A ; Specify memory bank 2 as a stack area
```

```
MOV XA,#00H
```

```
MOV SP,XA ; SP <- 00H
```

Figure 4-9. Data Saved to Stack Memory

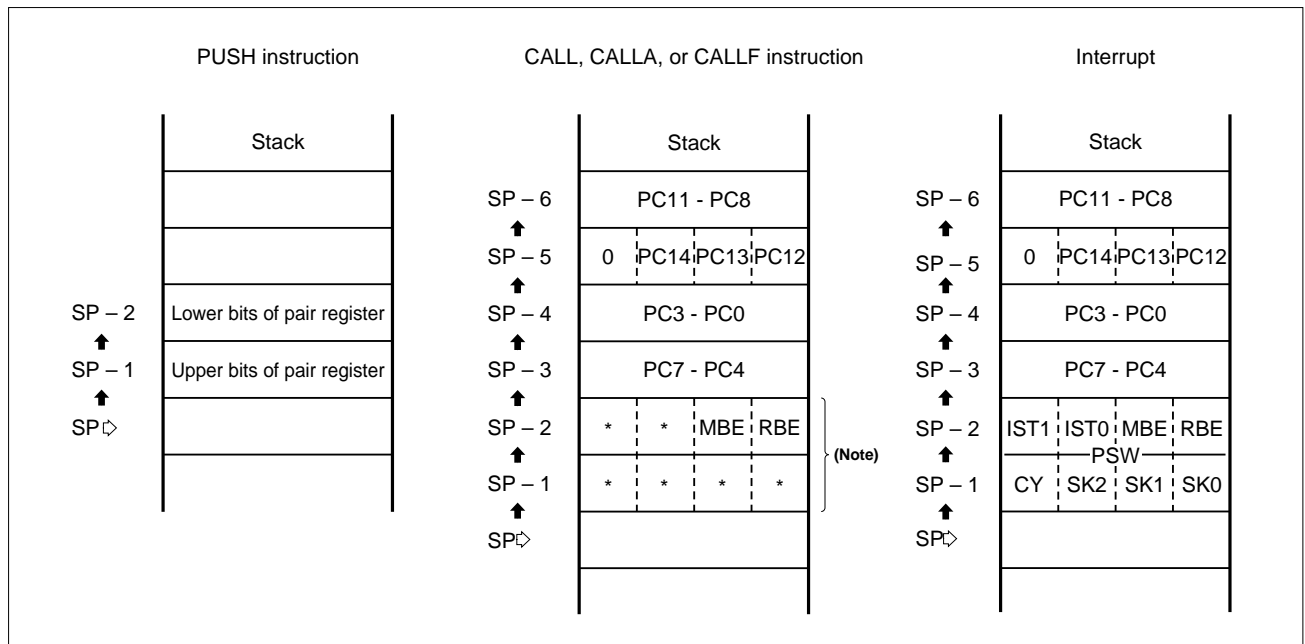
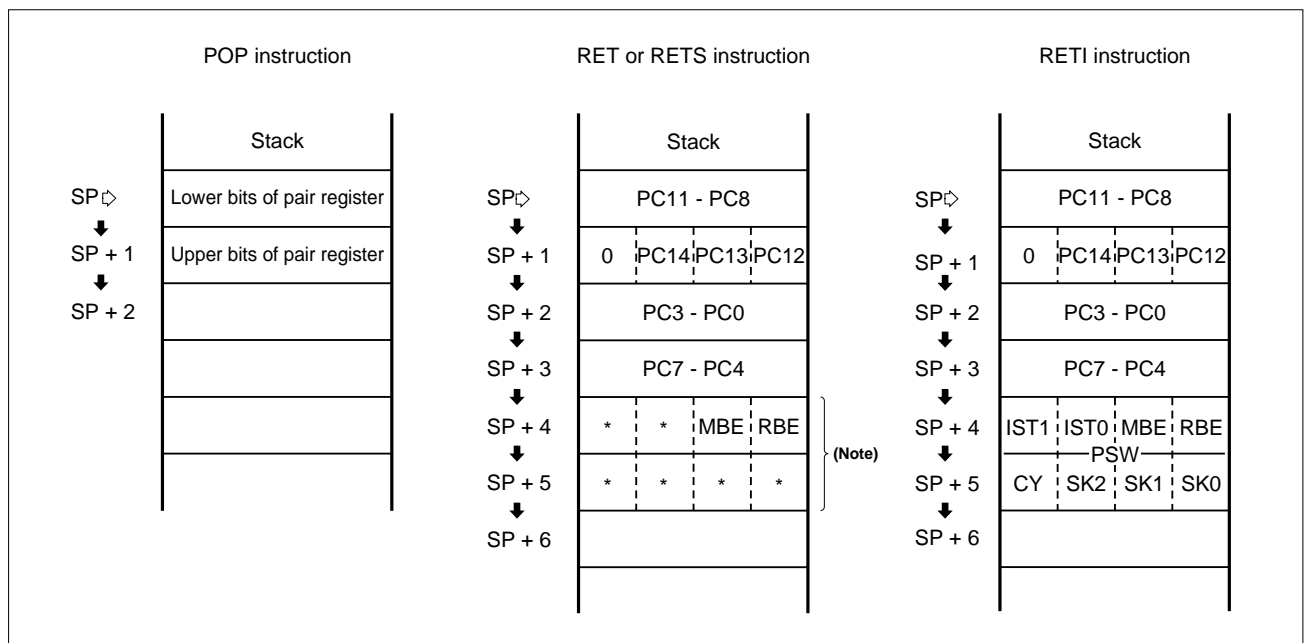

Figure 4-10. Data Restored from Stack Memory



(Note) A PSW other than the MBE or RBE is not saved/restored.

Remark Data marked with * is undefined.

4.7 Program Status Word (PSW): 8 Bits

The program status word (PSW) consists of various flags closely associated with processor operations.

The PSW is mapped to addresses FB0H and FB1H in data memory space. Four bits at address FB0H can be manipulated with a memory manipulation instruction. Address FB1H cannot be manipulated with a normal data memory manipulation instruction.

Figure 4-11. Program Status Word Format

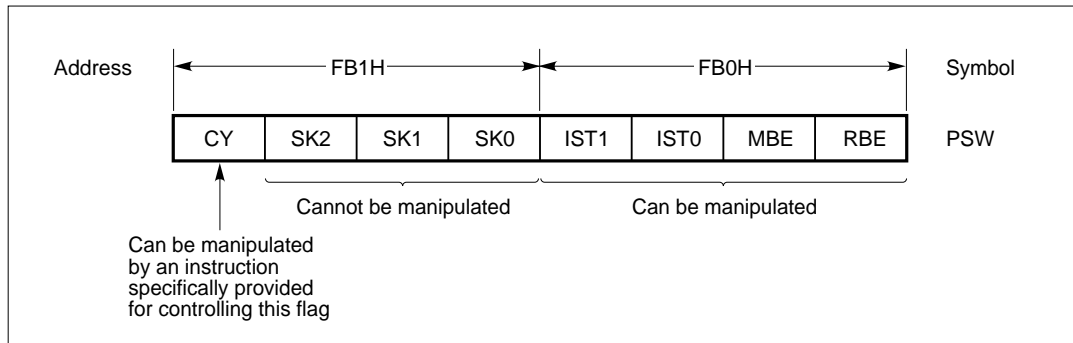

All or some of PSW bits are saved to and restored from stack memory when a subroutine call instruction or a hardware interrupt is executed. PSW flags to be manipulated at the time of a stack operation are listed in Table 4-2.

Table 4-2. PSW Flags Saved/Restored in Stack Operation

		Saved/restored flag
Save	When a CALL, CALLA, or CALLF instruction is executed	MBE and RBE are saved.
	When a hardware interrupt occurs	All PSW bits are saved.
Restore	When a RET or RETS instruction is executed	MBE and RBE are restored.
	When a RETI instruction is executed	All PSW bits are restored.

(1) Carry flag (CY)

The carry flag is a 1-bit flag used to store information about an overflow or underflow that occurs when an arithmetic operation with a carry (ADDC, SUBC) is executed.

The carry flag functions as a bit accumulator, and therefore can be used to store the result of a Boolean algebra operation performed on the CY and a bit at a specified data memory bit address.

The carry flag is manipulated using special instructions, independently of the other PSW bits.

A $\overline{\text{RESET}}$ signal causes the carry flag to be undefined.

Table 4-3. Carry Flag Manipulation Instructions

	Instruction (mnemonic)		Carry flag operation/processing
Instruction dedicated to carry flag manipulation	SET1	CY	Sets CY to 1.
	CLR1	CY	Clears CY to 0.
	NOT1	CY	Inverts the state of CY.
	SKT	CY	Skips if CY is 1.
Bit transfer instruction	MOV1	*1 CY	Transfers the state of CY to a specified bit.
	MOV1	CY, *1	Transfers the state of a specified bit to CY.
Bit Boolean instruction	AND1	CY, *1	ANDs, ORs, or XORs CY with a specified bit, then sets the result in CY.
	OR1	CY, *1	
	XOR1	CY, *1	
Interrupt handling	Interrupt execution		Saves CY and all other PSW bits to stack memory in parallel.
	RETI		Restores CY together with the other PSW bits from stack memory in parallel.

Remark *1 represents the following bit addressing:

- fmem.bit
- pmem.@L
- @H+mem.bit

Example Bit 3 at address 3FH is ANDed with P33, then the result is set in P50.

```

MOV    H,#3H           ; Set the high-order 4 bits of the address in H register
MOV1   CY,@H+0FH.3    ; CY <- bit 3 at 3FH
AND1   CY,PORT3.3     ; CY <- CY^P33
MOV1   PORT5.0,CY     ; P50 <- CY
    
```

(2) Skip flags (SK2, SK1, SK0)

The skip flags are used to store skip status, and are automatically set or reset when the CPU executes an instruction.

The user cannot directly manipulate these flags by specifying an operand.

(3) Interrupt status flag (IST1, IST0)

The interrupt status flag is a 2-bit flag used to store the status of processing being performed.

Table 4-4. Information Indicated by the Interrupt Status Flag

IST1	IST0	Status of processing	Processing and interrupt control being performed
0	0	Status 0	Normal program processing is being performed. Any interrupts are acceptable.
0	1	Status 1	A lower- or higher-priority interrupt is being serviced. Higher-priority interrupts are acceptable.
1	0	Status 2	A higher-priority interrupt is being serviced. No interrupts are acceptable.
1	1	—	Not to be set

The interrupt priority control circuit (**Figure 6-1**) checks this flag to control multiple interrupts.

The contents of the IST1 and IST0 are saved as part of the PSW to stack memory if an interrupt is accepted, then are automatically set to a one-step higher status. The RETI instruction restores the contents present before an interrupt occurs.

The interrupt status flag can be manipulated using a memory manipulation instruction, and the status of processing being performed can be changed by program control.

Caution **The user must always disable interrupts with the DI instruction before manipulating this flag, and must enable interrupts with the EI instruction after manipulating this flag.**

(4) Memory bank enable flag (MBE)

The memory bank enable flag is a 1-bit flag used to specify the address information generation mode for the high-order four bits of a 12-bit data memory address.

The MBE can be set or reset any time with a bit manipulation instruction, regardless of memory bank setting.

When the MBE is set to 1, the data memory address space is expanded according to the setting of the MBS, allowing all data memory space to be addressed.

When the MBE is reset to 0, the data memory address space is fixed, regardless of MBS setting. (See **Figure 3-2.**)

A $\overline{\text{RESET}}$ signal automatically initializes the MBE by setting the MBE to the content of bit 7 at program memory address 0.

In vectored interrupt processing, the MBE is automatically set to the content of bit 7 in the vector address table for servicing the interrupt.

Usually, the MBE is set to 0 in interrupt processing, and static RAM in memory bank 0 is used.

(5) Register bank enable flag (RBE)

The register bank enable flag is a 1-bit flag used to determine whether to expand the general register bank configuration.

The RBE can be set or reset any time with a bit manipulation instruction, regardless of memory bank setting.

When the RBE is set to 1, a set of general registers can be selected from register banks 0 to 3, depending on the setting of the register bank select register (RBS).

When the RBE is reset to 0, register bank 0 is always selected as general registers, regardless of the setting of the RBS.

A $\overline{\text{RESET}}$ signal automatically initializes the RBE by setting the RBE to the state of bit 6 at program memory address 0.

When a vectored interrupt occurs, the RBE is automatically set to the state of bit 6 in the vector address table for servicing the interrupt. Usually, the RBE is set to 0 in interrupt processing. Register bank 0 is used for 4-bit processing, and register banks 0 and 1 are used for 8-bit processing.

4.8 Bank Select Register (BS)

The bank select register (BS) consists of a register bank select register (RBS) and memory bank select register (MBS), which specify a register bank and memory bank to be used, respectively.

The RBS and MBS are set using the SEL RBn instruction and SEL MBn instruction, respectively.

The contents of the BS can be saved to or restored from a stack memory eight bits at a time by using the PUSH BS/POP BS instruction.

Figure 4-12. Bank Select Register Format

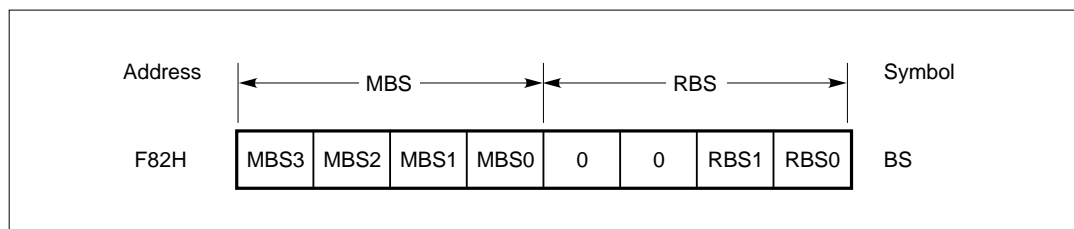

(1) Memory bank select register (MBS)

The memory bank select register is a 4-bit register used to store the high-order four bits of a 12-bit data memory address. The contents of this register specify a memory bank to be accessed. The μ PD75518 allows memory banks 0 to 3 and 15 only to be specified.

The MBS is set with the SEL MBn instruction (n = 0, 1, 2, 3, 15).

Figure 3-2 shows the range of addressing using MBE and MBS settings.

A $\overline{\text{RESET}}$ signal initializes the MBS to 0.

(2) Register bank select register (RBS)

The register bank select register specifies a register bank to be used as general registers; a register bank can be selected from register banks 0 to 3.

The RBS is set by the SEL RBn instruction (n = 0 to 3).

A $\overline{\text{RESET}}$ signal initializes the RBS to 0.

Table 4-5. Register Bank to Be Selected with the RBE and RBS

RBE	RBS				Register bank
	3	2	1	0	
0	0	0	x	x	Bank 0 is always selected.
1	0	0	0	0	Bank 0 is selected.
			0	1	Bank 1 is selected.
			1	0	Bank 2 is selected.
			1	1	Bank 3 is selected.



x: Don't care

[MEMO]

Chapter 5

Peripheral Hardware Functions

5.1 Digital I/O Ports

The μ PD75518 contains digital I/O ports, port 0 to port 15.

The μ PD75518 employs memory-mapped I/O. This means that all I/O ports are mapped to data memory space.

All data memory manipulation instructions are applicable to the ports of the μ PD75518, enabling a wide range of control; 8-bit I/O and bit manipulation on a specified bit are enabled as well as 4-bit I/O.

Figure 5-1. Data Memory Address Assigned to Digital I/O Ports

Address	3	2	1	0	Symbol
FF0H	P03	P02	P01	P00	PORT 0
FF1H	P13	P12	P11	P10	PORT 1
FF2H	P23	P22	P21	P20	PORT 2
FF3H	P33	P32	P31	P30	PORT 3
FF4H	P43	P42	P41	P40	PORT 4
FF5H	P53	P52	P51	P50	PORT 5
FF6H	P63	P62	P61	P60	PORT 6
FF7H	P73	P72	P71	P70	PORT 7
FF8H	P83	P82	P81	P80	PORT 8
FF9H	P93	P92	P91	P90	PORT 9
FFAH	P103	P102	P101	P100	PORT 10
FFBH	P113	P112	P111	P110	PORT 11
FFCH	P123	P122	P121	P120	PORT 12
FFDH	P133	P132	P131	P130	PORT 13
FFEH	P143	P142	P141	P140	PORT 14
FFFH	P153	P152	P151	P150	PORT 15

5.1.1 Types, Features, and Configurations of Digital I/O Ports

Table 5-1 lists the types of digital I/O ports.

Figures 5-2 to 5-8 show the configurations of the ports.

Table 5-1. Types and Features of Digital I/O Ports

Port name	Function	Operation and feature		Remarks
PORT0	4-bit input	Allows read and test at any time regardless of the operation modes of dual function pins.		Also used as INT4, SCK0, SO0/SB0, and SI0/SB1.
PORT1				Also used as INT0 to INT2, and TI0.
PORT2	4-bit I/O	Allows input or output mode setting in units of 4 bits.		Also used as PTO0, PCL, and BUZ.
PORT3(Note)		Allows input or output mode setting in 1- or 4-bit units.		—
PORT4(Note)	4-bit I/O (N-channel open-drain 10 V)	Allows input or output mode setting in units of 4 bits.	Ports 4 and 5 may be paired, allowing data I/O in units of 8 bits.	The use of pull-up resistors can be specified by mask options in bit units.
PORT5(Note)				
PORT6	4-bit I/O	Allows input or output mode setting in 1- or 4-bit units.	Ports 6 and 7 may be paired, allowing data I/O in units of 8 bits.	Also used as KR0 to KR3.
PORT7		Allows input or output mode setting in units of 4 bits.		Also used as KR4 to KR7.
PORT8	4-bit input	Allows read and test at any time regardless of the operation modes of dual function pins.		Also used as PPO, SCK1, SO1, and SI1.
PORT9	4-bit I/O	Allows input or output mode setting in units of 4 bits.		The use of a pull-down resistor can be specified by a mask option in bit units.
PORT10	4-bit I/O	Allows input or output mode setting in units of 4 bits.		—
PORT11				
PORT12	4-bit I/O (N-channel open-drain 10 V)	Allows input or output mode setting in units of 4 bits.		The use of pull-up resistors can be specified by mask options in bit units.
PORT13				
PORT14				
PORT15	4-bit input	Allows read and test at any time regardless of the operation modes of dual function pins.		Also used as AN4 to AN7.

(Note) This port can directly drive the LED.

Ports 3 and 4 can directly drive the LED. Up to 200 mA (peak value) can flow at the same time in total for all pins.

The N-ch transistors at the outputs of ports 4, 5, and 12 to 14 withstand +10 V to allow effective interface with peripheral LSI devices having different power supply voltages.

In the μ PD75518, a pull-up resistor can be provided for ports 4, 5, and 12 to 14, and a pull-down resistor can be provided for port 9 bit by bit. These ports can therefore be used as input pins for the key switches or key matrix.

Figure 5-2. Configurations of Ports 0, 1, and 8

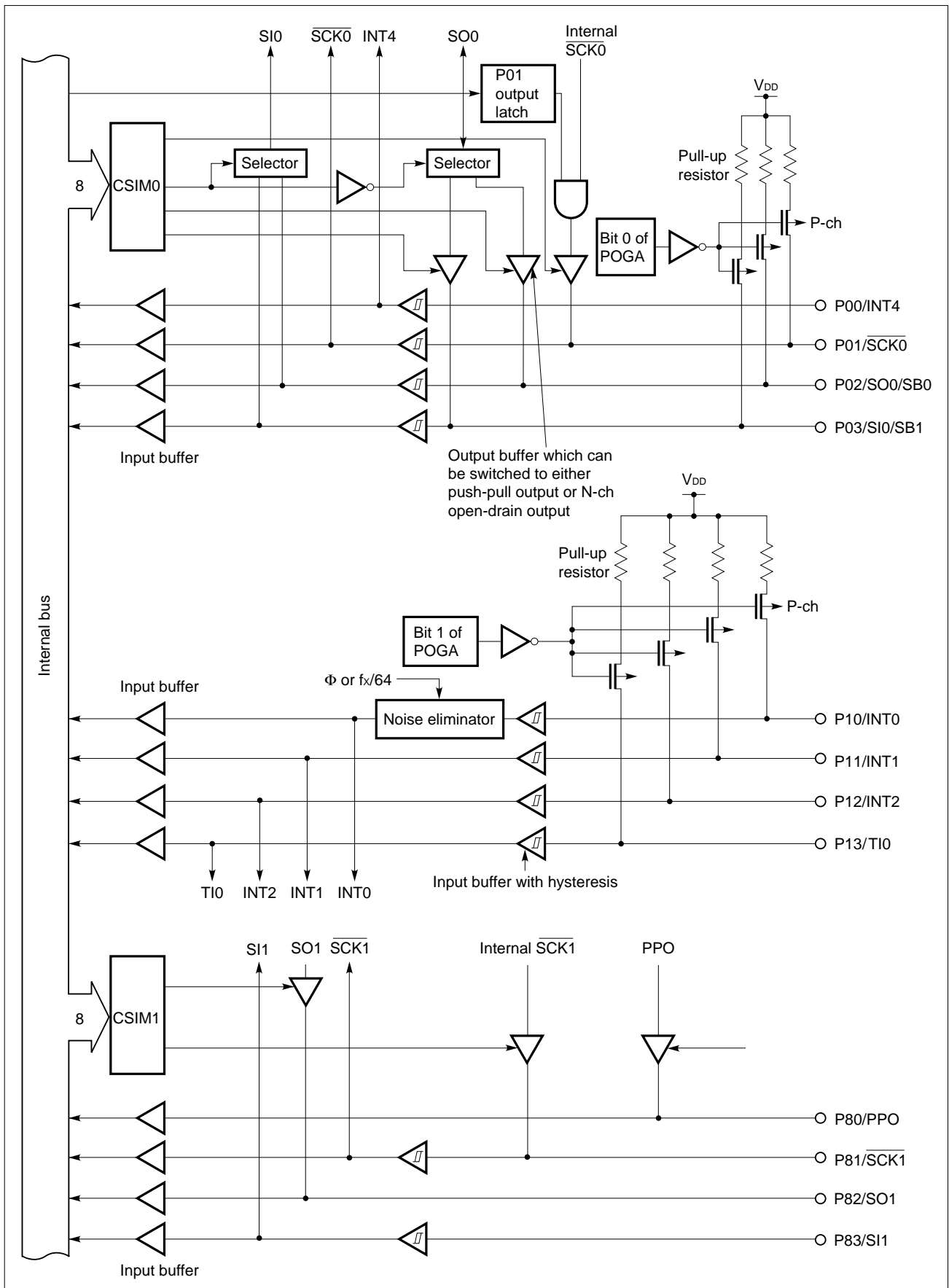

Figure 5-3. Configurations of Ports 3n and 6n (n = 0 to 3)

*

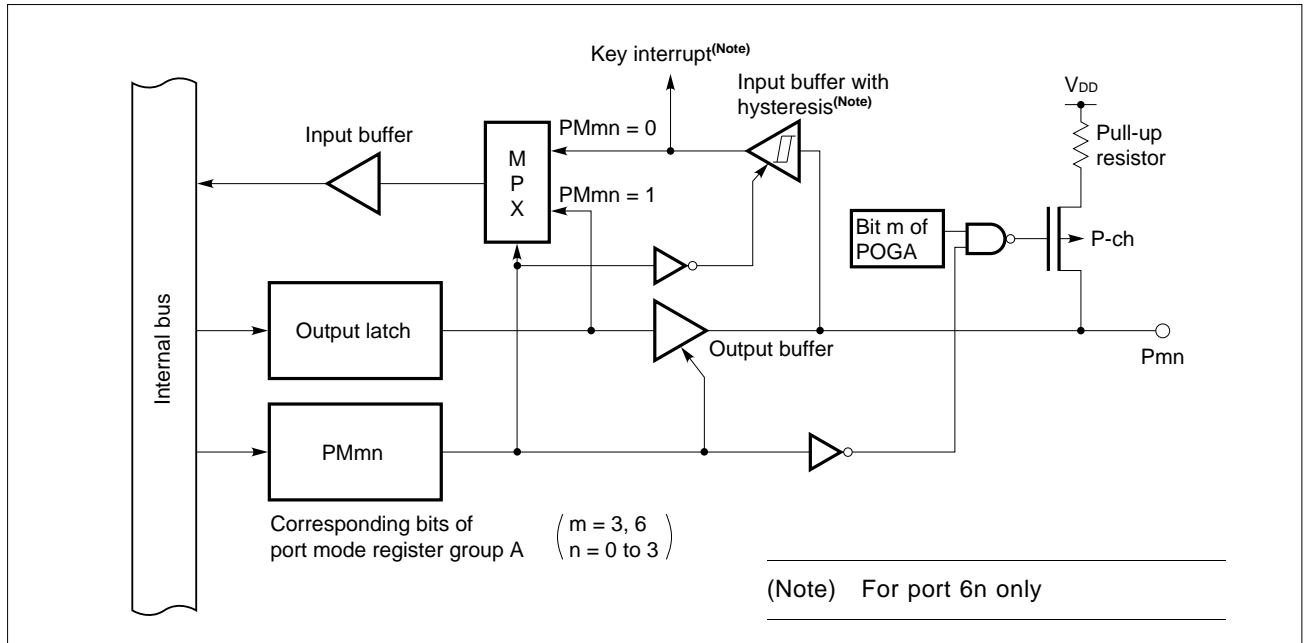

Figure 5-4. Configurations of Ports 2 and 7

*

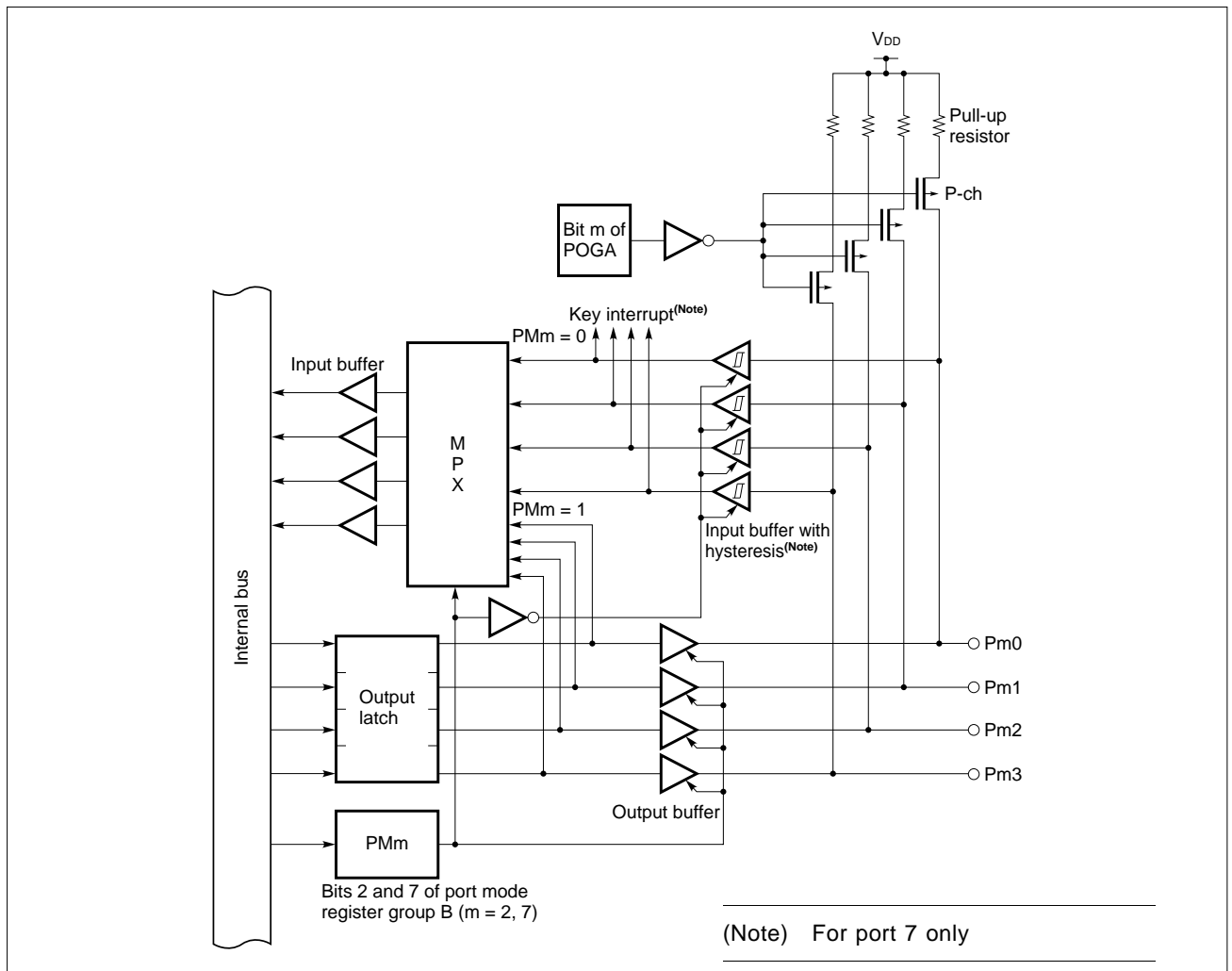

Figure 5-5. Configurations of Ports 4, 5, 12, 13, and 14

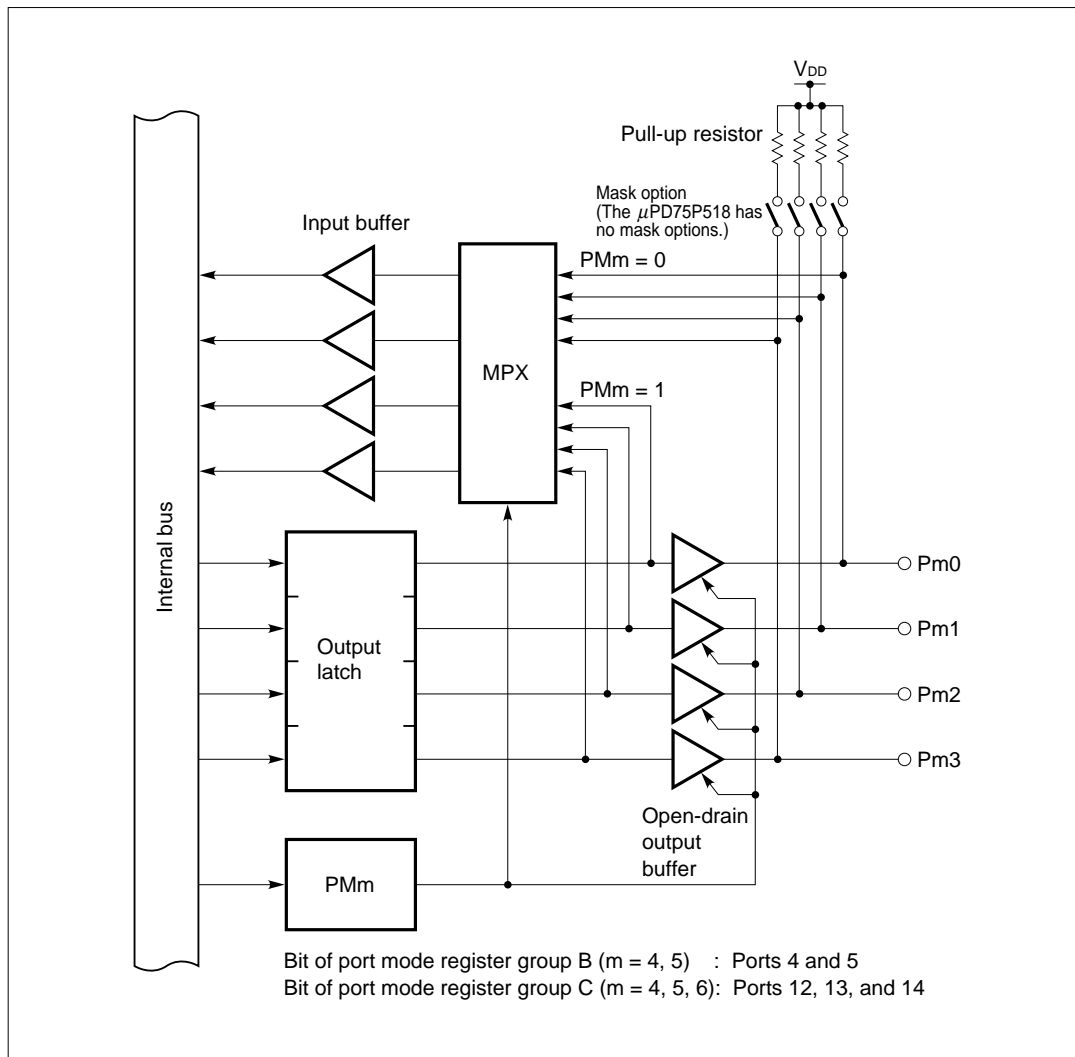

Figure 5-6. Configuration of Port 9

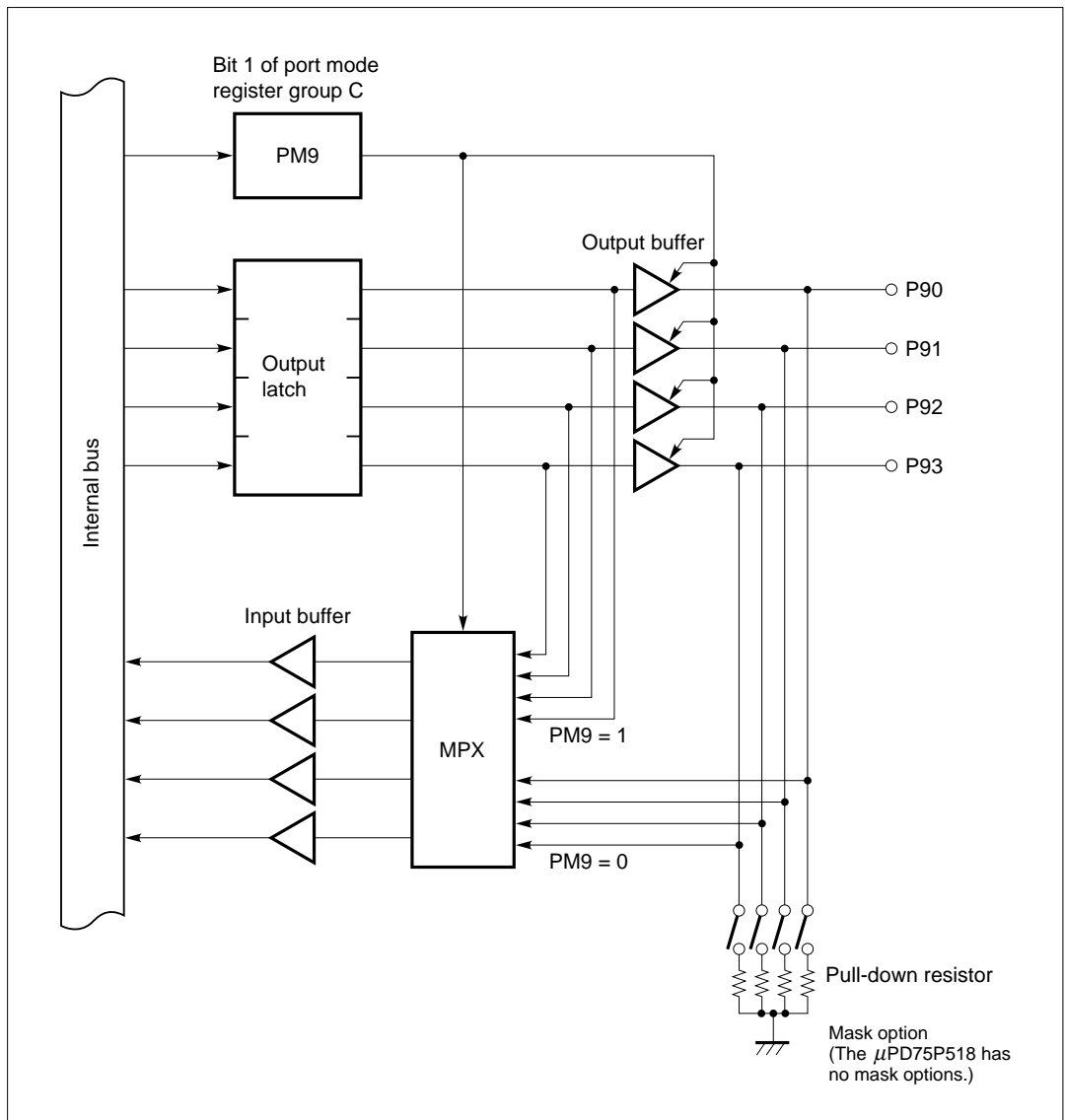

Figure 5-7. Configurations of Ports 10 and 11

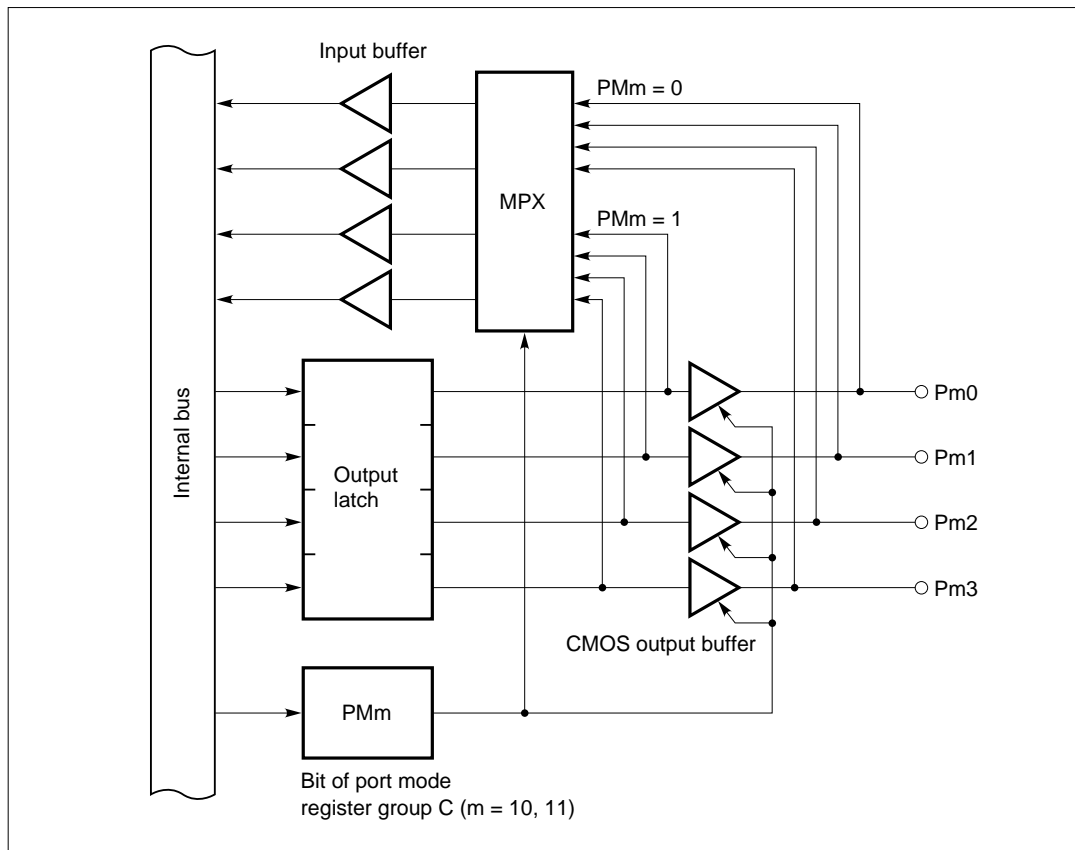
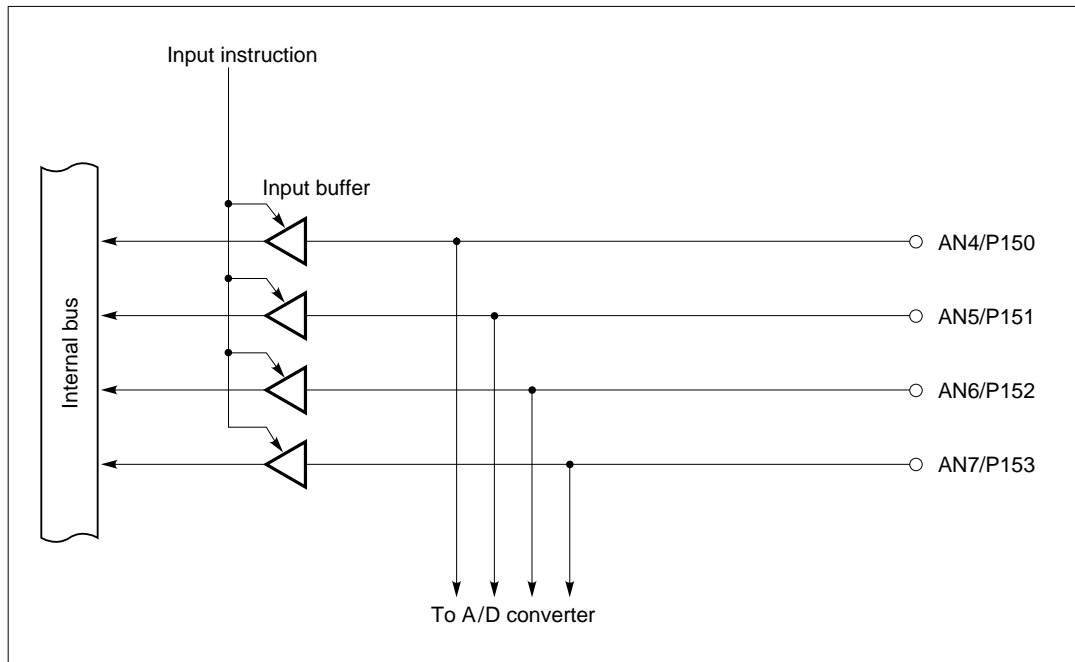

Figure 5-8. Configuration of Port 15



5.1.2 I/O Mode Setting

The I/O mode of each I/O port is set by the port mode register as shown in Figure 5-9. The I/O modes of ports 3 and 6 can be set bit by bit by port mode register group A (PMGA). The I/O modes of ports 2, 4, 5, and 7 can be set in units of four bits by port mode register group B (PMGB). The I/O modes of port 8 to port 14 can be set in units of four bits by port mode register group C (PMGC).

Each port functions as an input port when the corresponding bit of the port mode register is set to 0, and functions as an output port when the same corresponding bit is set to 1.

When the output mode is selected by the port mode register, the contents of the output latch appear on the output pins, and so the contents of the output latch must be changed to a desired value before the output mode is set.

An 8-bit memory manipulation instruction is used to set port mode register group A, B, or C.

A $\overline{\text{RESET}}$ signal clears all bits of each port mode register to 0. This means that the output buffers are set off, and all ports are placed in the input mode.

Example P30, P31, P62, and P63 are used as input pins, and P32, P33, P60, and P61 are used as output pins.

```
CLR1   MBE           ; or SEL MB15
MOV    XA,#3CH
MOV    PMGA,XA
```

Figure 5-9. Formats of Port Mode Registers (1/2)

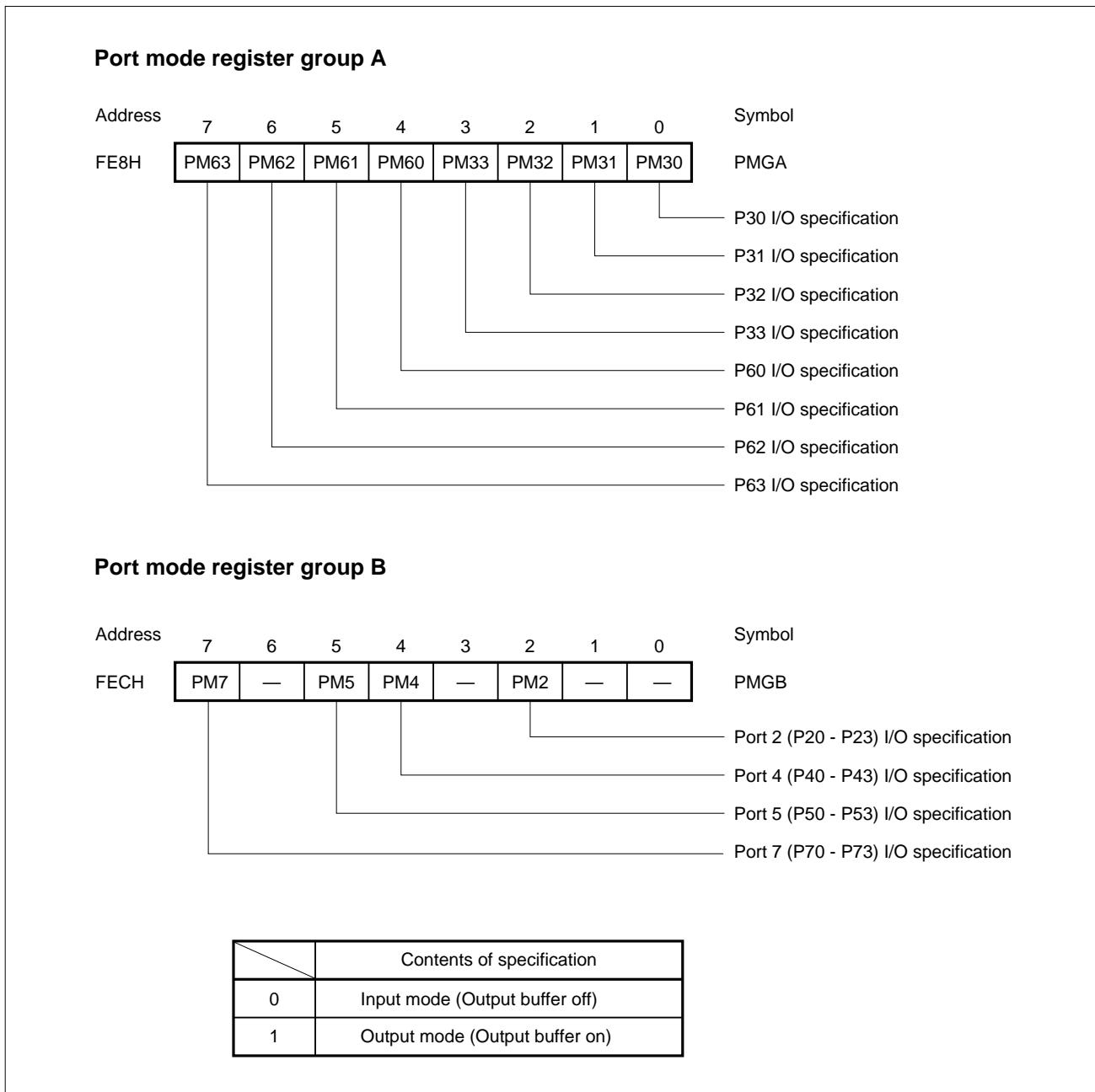

Remark —: Don't care

Figure 5-9. Formats of Port Mode Registers (2/2)

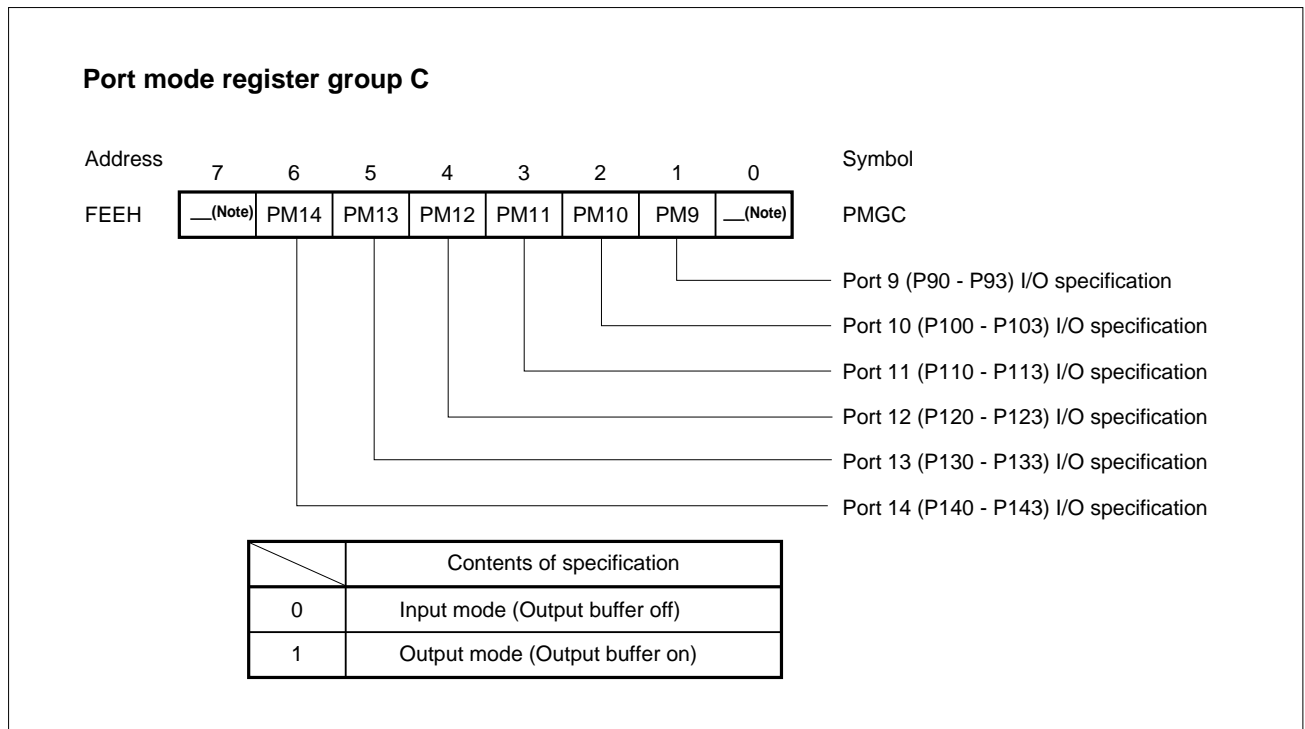

(Note) To develop a program, these bits must be set to 0. They correspond to PM8 and PM15. While this chip is an input-only device, an emulator has I/O ports.

5.1.3 Digital I/O Port Manipulation Instructions

All I/O ports contained in the μ PD75518 are mapped to data memory space, so that all data memory manipulation instructions can be used. Table 5-2 lists the instructions that are particularly useful for I/O pin manipulation and their application ranges.

(1) Bit manipulation instructions

For digital I/O ports PORT0 to PORT15, specific address bit direct addressing (fmem.bit) and specific address bit register indirect addressing (pmem.@L) can be used. This means that bit manipulation can be freely performed for these ports regardless of MBE and MBS settings.

Example P50 is ORed with P81, then the result is output to P61.

```
MOV1    CY,PORT5.0    ; CY <- P50
OR1     CY,PORT8.1    ; CY <- CY∨P81
MOV1    PORT6.1,CY    ; P61 <- CY
```

(2) 4-bit manipulation instructions

All 4-bit memory manipulation instructions including the IN, OUT, MOV, XCH, ADDS, and INCS instructions can be used. However, before these instructions can be executed, memory bank 15 must be selected.

Example 1. The contents of the accumulator are output to port 3.

```
SEL     MB15          ; or CLR1 MBE
OUT     PORT3,A
```

Example 2. The value of the accumulator is added to the data output on port 5, then the result is output.

```
SET1    MBE
SEL     MB15
MOV     HL,#PORT5
ADDS   A,@HL          ; A <- A+PORT5
NOP
MOV     @HL,A         ; PORT5 <- A
```

Example 3. Whether the data on port 4 is greater than the value of the accumulator is tested.

```
SET1   MBE
SEL    MB15
MOV    HL,#PORT4
SUBS   A,@HL      ; A < PORT4
BR     NO          ; NO
                        ; YES
```

(3) 8-bit manipulation instructions

The MOV, XCH, and SKE instructions as well as the IN and OUT instructions can be used for ports 4, 5, 6, and 7 that allow 8-bit manipulation. As with 4-bit manipulation, memory bank 15 must be selected in advance.

Example The data contained in the BC register pair is output on the output port specified by 8-bit data applied to ports 4 and 5.

```
SET1   MBE
SEL    MB15
IN     XA,PORT4    ; XA <- ports 5,4
MOV    HL,XA       ; HL <- XA
MOV    XA,BC       ; XA <- BC
MOV    @HL,XA      ; Port (L) <- XA
```

Table 5-2. I/O Pin Manipulation Instructions

PORT		0	1	2	3	4	5	6	7	8	9	10	11	12	13	14	15
IN	A,PORTn(Note 1)	o															
IN	XA,PORTn(Note 1)	—	—	—	—	o	o	—	—	—	—	—	—	—	—	—	—
OUT	PORTn.A(Note 1)	—	—	—	—	o	o	—	—	—	—	o	o	—	—	—	—
OUT	PORTn.XA(Note 1)	—	—	—	—	o	o	—	—	—	—	—	—	—	—	—	—
SET1	PORTn.bit	—	—	—	—	o	o	—	—	—	—	o	o	—	—	—	—
SET1	PORTn.@L(Note 2)	—	—	—	—	o	o	—	—	—	—	o	o	—	—	—	—
CLR1	PORTn.bit	—	—	—	—	o	o	—	—	—	—	o	o	—	—	—	—
CLR1	PORTn.@L(Note 2)	—	—	—	—	o	o	—	—	—	—	o	o	—	—	—	—
SKT	PORTn.bit	o															
SKT	PORTn.@L(Note 2)	o															
SKF	PORTn.bit	o															
SKF	PORTn.@L(Note 2)	o															
MOV1	CY,PORTn.bit	o															
MOV1	CY,PORTn.@L(Note 2)	o															
MOV1	PORTn.bit,CY	—	—	—	—	o	o	—	—	—	—	o	o	—	—	—	—
MOV1	PORTn.@L,CY(Note 2)	—	—	—	—	o	o	—	—	—	—	o	o	—	—	—	—
AND1	CY,PORTn.bit	o															
AND1	CY,PORTn.@L(Note 2)	o															
OR1	CY,PORTn.bit	o															
OR1	CY,PORTn.@L(Note 2)	o															
XOR1	CY,PORTn.bit	o															
XOR1	CY,PORTn.@L(Note 2)	o															

(Note 1) MBE = 0 or (MBE = 1, MBS = 15) must be set before execution.

(Note 2) The low-order two bits of an address and bit address are indirectly specified using the L register.

5.1.4 Digital I/O Port Operation

When a data memory manipulation instruction is executed for a digital I/O port, the operation of the port and pins depends on the I/O mode setting (Table 5-3). This is because data taken in on the internal bus is the data input from the pins in the input mode, or the output latch data in the output mode, as obvious from the configurations of I/O ports.

(1) Operation when the input mode is set

- Data from each pin is taken in when a test instruction such as the SKT instruction, a bit input instruction by the MOV1 instruction, or an instruction for taking in port data on the internal bus in units of four or eight bits (such as an IN, OUT, arithmetic/logical or comparison instruction) is executed.
- When an instruction (the OUT or MOV instruction) is executed to transfer the contents of the accumulator to a port in units of four or eight bits, the data of the accumulator is latched in the output latch, with the output buffers kept off.
- When the XCH instruction is executed, the data on each pin is loaded into the accumulator, and the data in the accumulator is latched in the output latch, with the output buffers kept off.
- When the INCS instruction is executed, the 4-bit data existing on the pins plus 1 is latched in the output latch, with the output buffers kept off.
- When an instruction such as the SET1, CLR1, MOV1, or SKTCLR instruction is executed to rewrite a data memory bit, the output latch data of the specified bit can be rewritten according to the instruction, but the states of the other output latch bits are undefined.

(2) Operation when the output mode is set

- When a test instruction, bit input instruction, or instruction for taking in port data on the internal bus in units of four or eight bits is executed, output latch data is manipulated.
- When an instruction is executed to transfer the contents of the accumulator in units of four or eight bits, the output latch data is rewritten, and is output on the pins.
- When the XCH instruction is executed, the output latch data is transferred to the accumulator. The contents of the accumulator are latched in the output latches, and are output on the pins.
- When the INCS instruction is executed, the contents of the output latch incremented by 1 are latched in the output latch, and are output on the pins.
- When a bit output instruction is executed, the specified bit of the output latch is rewritten, and is output on the pin.

Table 5-3. Operations by I/O Port Manipulation Instructions

Instruction	Port and pin operation	
	Input mode	Output mode
SKT * SKF *	Pin data is tested.	Output latch data is tested.
MOV1 CY, *	Pin data is transferred to CY.	Output latch data is transferred to CY.
AND1 CY, * OR1 CY, * XOR1 CY, *	An operation is performed on pin data and CY.	An operation is performed on output latch data and CY.
IN A,PORTn IN XA,PORTn MOV A,@HL MOV XA,@HL	Pin data is transferred to the accumulator.	Output latch data is transferred to the accumulator.
ADDS A,@HL ADDC A,@HL SUBS A,@HL SUBC A,@HL AND A,@HL OR A,@HL XOR A,@HL	An operation is performed on pin data and the accumulator.	An operation is performed on output latch data and the accumulator.
SKE A,@HL SKE XA,@HL	Pin data is compared with the accumulator.	Output latch data is compared with the accumulator.
OUT PORTn,A OUT PORTn,XA MOV @HL,A MOV @HL,XA	Accumulator data is transferred to the output latch (with the output buffers kept off).	Accumulator data is transferred to the output latch and is output on the pins.
XCH A,PORTn XCH XA,PORTn XCH A,@HL XCH XA,@HL	Pin data is transferred to the accumulator, and accumulator data is transferred to the output latch (with the output buffers kept off).	Data is exchanged between the output latch and accumulator.
INCS PORTn INCS @HL	Pin data incremented by 1 is latched in the output latch.	Output latch data is incremented by 1.
SET1 * CLR1 * MOV1 * ,CY SKTCLR *	The output latch data of a specified bit is rewritten, but the output latch data of the other bits is undefined.	The output pin state is modified according to the instruction.

* Represents an addressing mode PORTn.bit or PORTn.@L.

5.1.5 Specification of Internal Pull-Up/Pull-Down Resistors

Each port (excluding P00 and the pins of ports 8, 10, 11, and 15) of the μ PD75518 can be provided with an internal pull-up or pull-down resistor. These resistors are specified as follows:

- Pull-up resistor : Software or mask option
- Pull-down resistor: Mask option only

The software uses the pull-up resistor register group A (POGA) to specify whether an internal pull-up resistor is incorporated.

Table 5-4 shows how a pull-up or pull-down resistor is specified for each port pin. Specification by software is based on the format given in Figure 5-10.

Table 5-4. Specification of Internal Pull-Up/Pull-Down Resistors

Port (pin name)	Specification of internal pull-up/pull-down resistor	Bit in POGA
Port 0 (P01-P03)(Note 1)	Internal pull-up resistors are specified by software in 3 bit units.	Bit 0
Port 1 (P10-P13)	Internal pull-up resistors are specified by software in 4-bit units.	Bit 1
Port 2 (P20-P23)		Bit 2
Port 3 (P30-P33)		Bit 3
Port 6 (P60-P63)		Bit 6
Port 7 (P70-P73)		Bit 7
Port 4 (P40-P43)	An internal pull-up resistor is specified bit by bit by mask option.(Note 2)	—
Port 5 (P50-P53)		
Port 12 (P120-P123)		
Port 13 (P130-P133)		
Port 14 (P140-P143)		
Port 9 (P90-P93)	An internal pull-down resistor is specified bit by bit by mask option.(Note 2)	—

(Note 1) The P00 pin cannot be provided with a pull-up resistor.

(Note 2) The pins of ports 4, 5, 9, and 12 to 14 of the μ PD75P518 cannot be provided with internal pull-up or pull-down resistors.

Figure 5-10. Format of the Pull-up Resistor Register

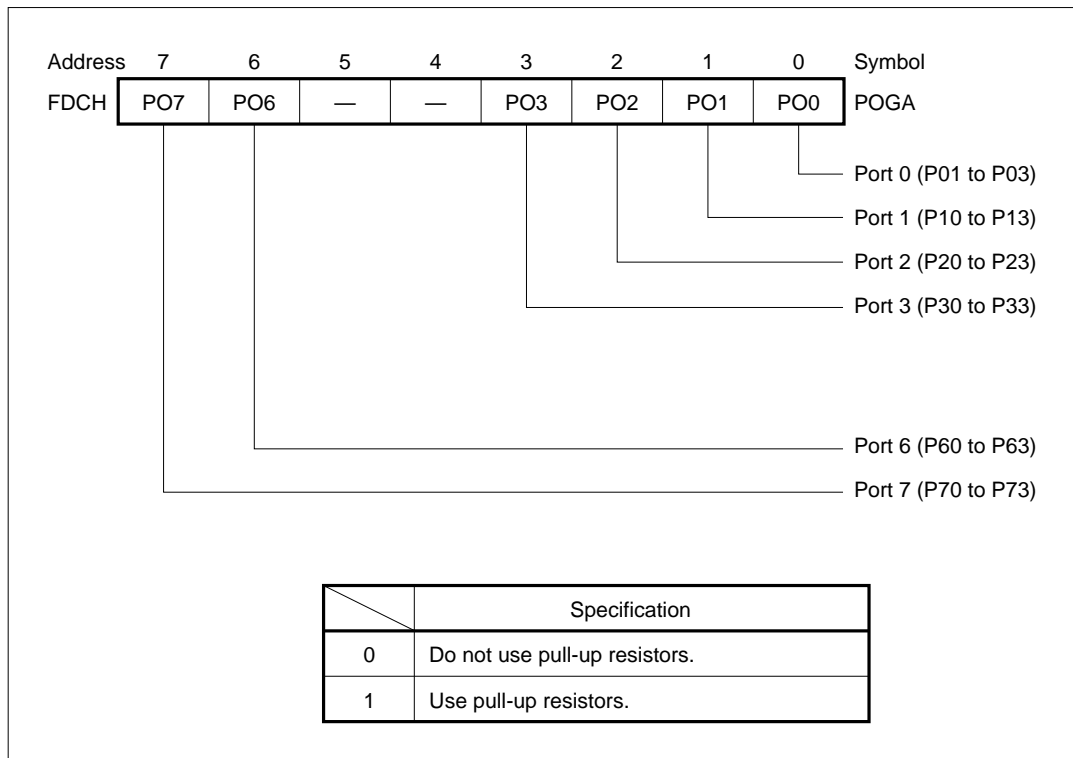

Caution No pull-up resistors are specified for the μ PD75P518 by mask option.

Figure 5-11 shows the timing at which the use of pull-up resistors is specified by setting of the pull-up resistor register (POGA).

Figure 5-11. ON Timing of Pull-up Resistors by Software

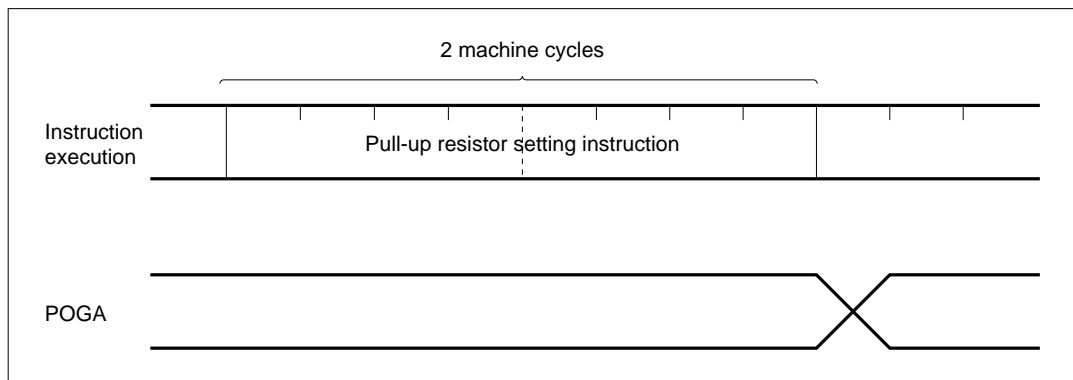

After rewriting the contents of POGA to specify the use of pull-up resistors, execute NOP instructions before I/O instructions in consideration of external load capacity.

Example Specify the use of pull-up resistors for PORT1, then input the I/O instruction.

```
SEL    MB15
MOV    XA,#02H    ; Provide pull-up resistors for PORT1
MOV    POGA,XA
      :           ] Wait for stabilization of the circuit in
      :           ] consideration of external load
      :
IN     A,PORT1
```

5.1.6 I/O Timing of Digital I/O Ports

Figure 5-12 shows the timing of data output to an output latch and the timing of taking in pin data or output latch data on the internal bus.

Figure 5-12. I/O Timing of Digital I/O Ports

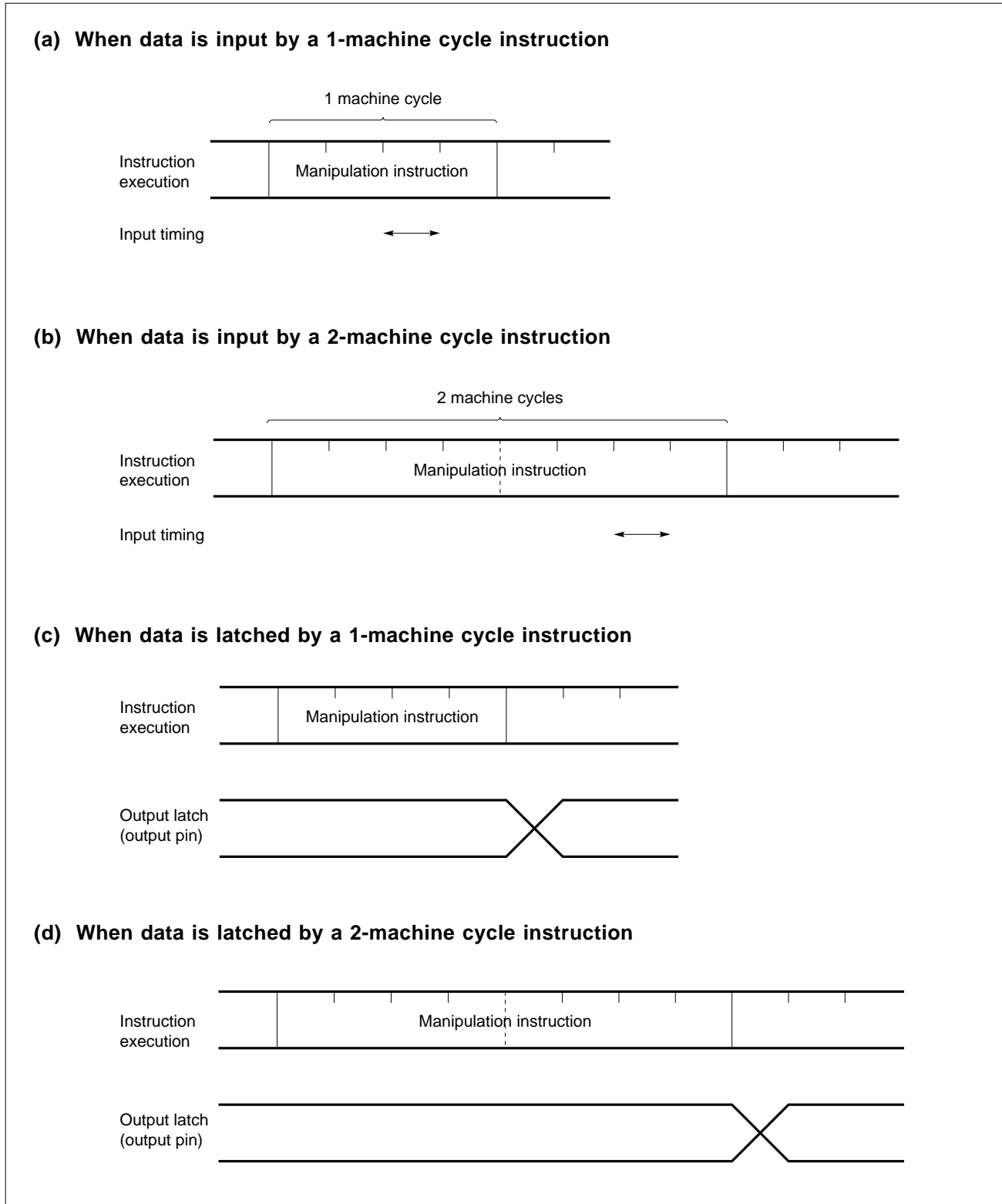

5.2 Clock Generator

The clock generator supplies various clock signals to the CPU and peripheral hardware to control the CPU operation mode.

5.2.1 Clock Generator Configuration

Figure 5-13 shows the configuration of the clock generator.

Figure 5-13. Block Diagram of the Clock Generator

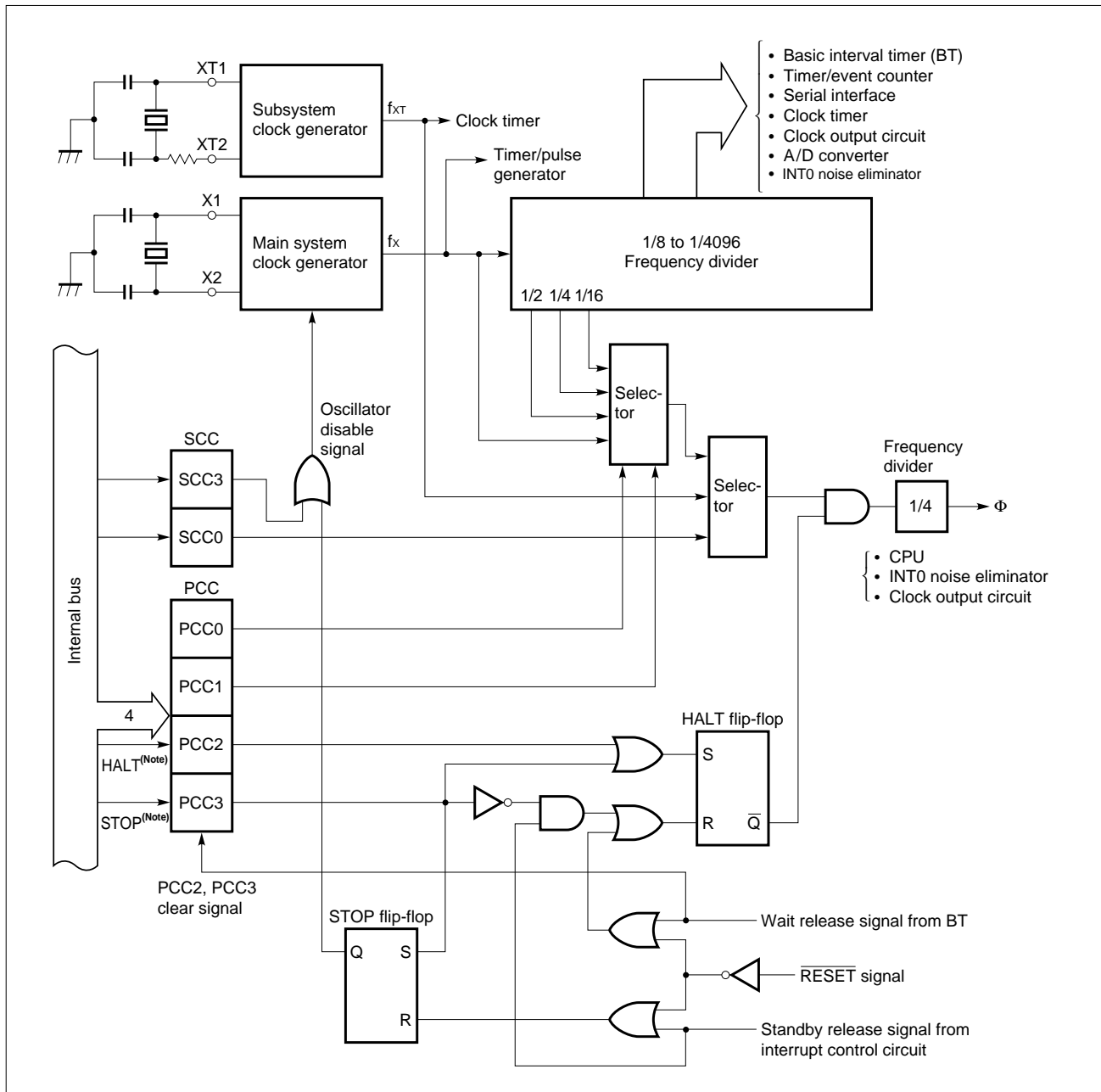

(Note) Instruction execution

- Remarks
1. f_X : Main system clock frequency
 2. f_{XT} : Subsystem clock frequency
 3. Φ = CPU clock
 4. PCC: Processor clock control register
 5. SCC: System clock control register
 6. One clock cycle (t_{CY}) of the CPU clock (Φ) is equal to one machine cycle of an instruction.

5.2.2 Functions and Operations of the Clock Generator

The clock generator generates the following clocks, and controls the CPU operation modes such as the standby mode.

- Main system clock f_X
- Subsystem clock f_{XT}
- CPU clock Φ
- Clock to peripheral hardware

The operation of the clock generator is determined by the processor clock control register (PCC) and system clock control register (SCC). The function and operation of the clock generator are described in (a) to (g) below.

- A $\overline{\text{RESET}}$ signal selects the lowest-speed mode (10.7 μs : At 6.0 MHz)(**Note 1**) for the main system clock (PCC = 0, SCC = 0).
- When the main system clock is selected, the PCC can be set to select one of four CPU clocks (0.67 μs , 1.33 μs , 2.67 μs , and 10.7 μs : At 6.0 MHz)(**Note 2**).
- When the main system clock is selected, the two standby modes, STOP mode and HALT mode, are available.
- The SCC can be set to select the subsystem clock for very low-speed, low-current operation (122 μs : At 32.768 kHz). The value in the PCC does not affect the CPU clock.
- When the subsystem clock is selected, main system clock generation can be stopped with the SCC. In addition, the HALT mode can be used, but the STOP mode cannot be used. (Subsystem clock generation cannot be stopped.)
- The clock to be supplied to peripheral hardware is produced by frequency-dividing the main system clock signal. The subsystem clock can directly be supplied only to the clock timer. This enables the clock function and the buzzer output function, which operate on the clock signal from the clock timer, to continue operating even in the standby state.
- When the subsystem clock is selected as the count clock of the clock timer, the clock timer can continue to operate normally. However, other hardware cannot be used when the main system clock is stopped because they operate with the main system clock.

(Note 1) At 4.19 MHz: 15.3 μs

(Note 2) At 4.19 MHz: 0.95 μs , 1.91 μs , 3.82 μs , and 15.3 μs

(1) Processor clock control register (PCC)

The PCC is a 4-bit register for selecting a CPU clock Φ with the low-order two bits and for controlling the CPU operation mode with the high-order two bits. Figure 5-14 shows the format.

When bit 3 or bit 2 is set to 1, the standby mode is set. When the standby mode is released by the standby release signal, these bits are automatically cleared to return to the normal operation mode. (See **Chapter 7** for details.)

A 4-bit memory manipulation instruction is used to set the low-order two bits of the PCC. (The high-order two bits are set to 0.)

Bit 3 and bit 2 are set to 1 using the STOP instruction and HALT instruction, respectively.

The STOP instruction and HALT instruction can always be executed regardless of MBE setting.

The CPU clock can be selected only while the processor is operated by the main system clock. When the processor is operated by the subsystem clock, the low-order 2 bits of the PCC are invalidated, and $f_{XT}/4$ is automatically set. The STOP instruction can be executed only when the processor is operated by the main system clock.

A $\overline{\text{RESET}}$ signal clears the PCC to 0.

Example 1. The machine cycle is set to 0.95 us (at 4.19 MHz).

```
SEL    MB15
MOV    A,#0011B
MOV    PCC,A
```

Example 2. The STOP mode is set. (A STOP instruction or HALT instruction must always be followed by an NOP instruction.)

```
STOP
NOP
```

Figure 5-14. Format of the Processor Clock Control Register

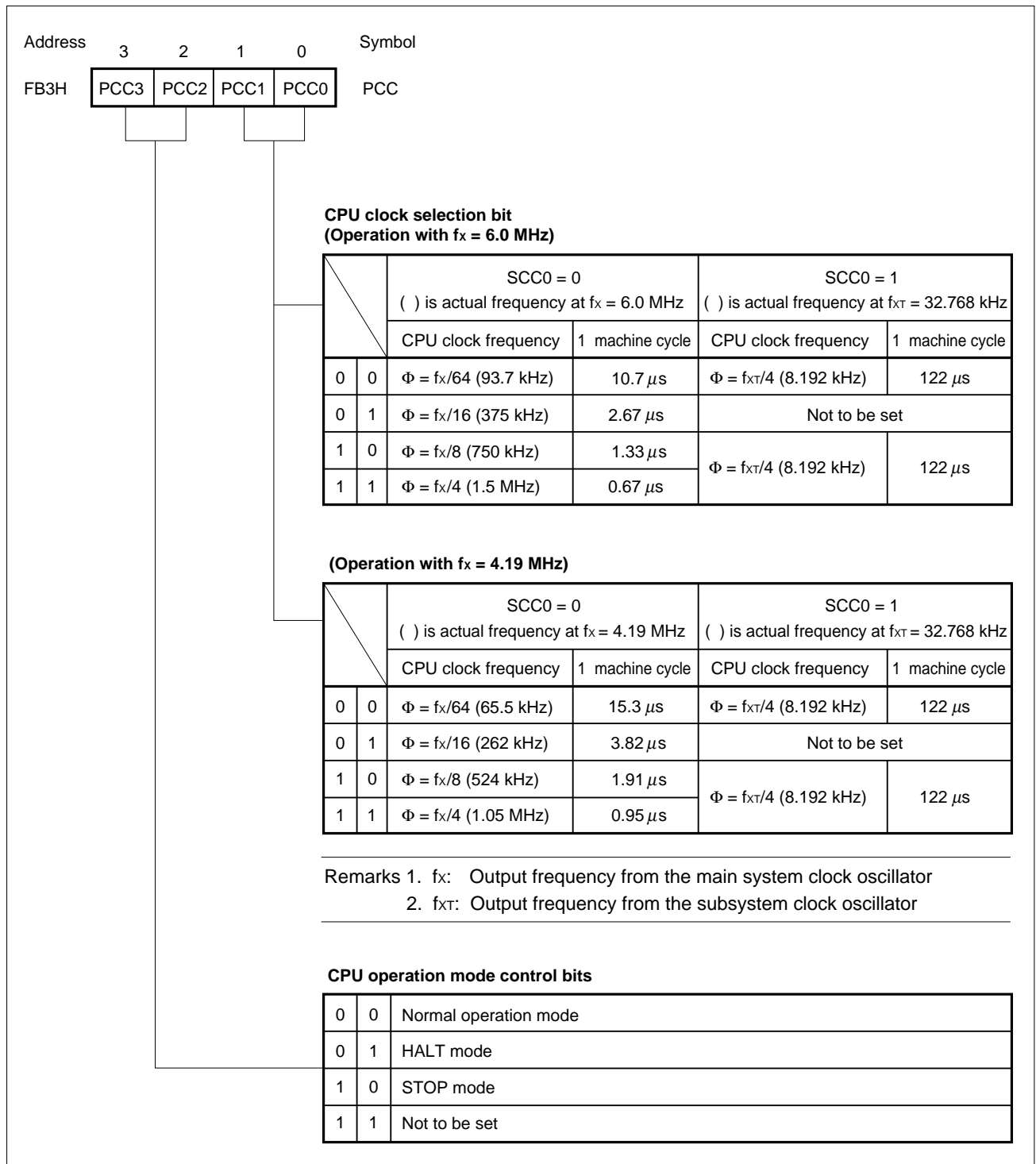

(2) System clock control register (SCC)

The SCC is a 4-bit register for selecting CPU clock Φ with the least significant bit and for controlling the termination of main system clock generation with the most significant bit. Figure 5-15 shows the format.

SCC.3 and SCC.0 are located at the same data memory address, but both bits cannot be changed at the same time. Accordingly, SCC.3 and SCC.0 are set using bit manipulation instructions. SCC.3 and SCC.0 can be manipulated regardless of MBE setting.

Main system clock generation can be terminated by setting SCC.3 only when the subsystem clock is used for operation. The STOP instruction must be used to terminate main system clock generation.

A $\overline{\text{RESET}}$ signal clears the SCC to 0.

Figure 5-15. Format of the System Clock Control Register

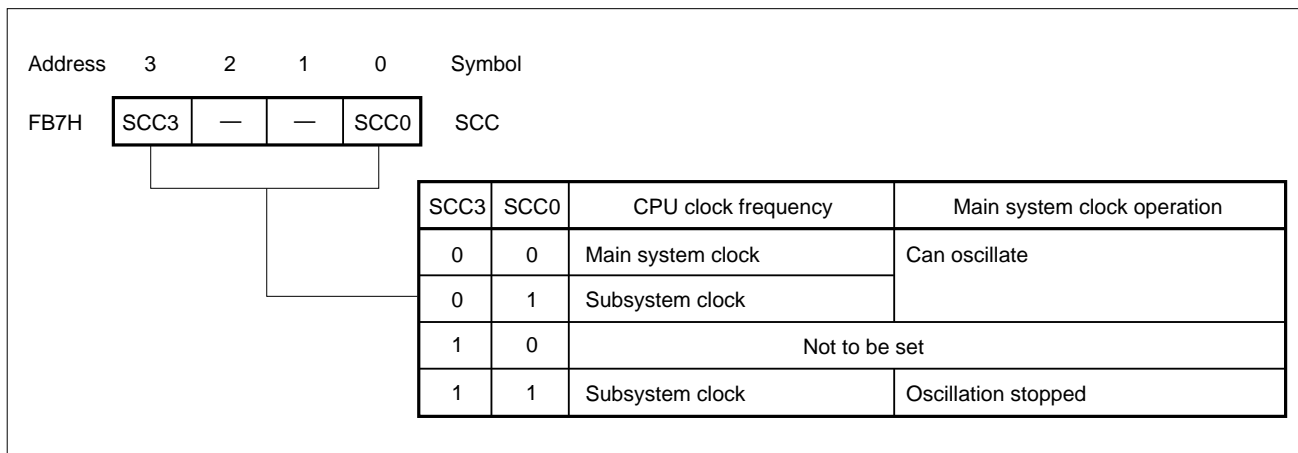

- Cautions 1.** A time period of up to $1/f_{XT}$ is needed to change the system clock. This means that to terminate main system clock generation, SCC.3 must be set when the machine cycles indicated in Table 5-1 or more have elapsed after the clock is switched from the main system clock to the subsystem clock.
- 2.** When the main system clock is used for operation, setting SCC.3 to stop clock generation does not enter the normal STOP mode.
- 3.** When SCC.3 is set to 1, the X1 input pin is connected to V_{SS} (ground electric potential) to prevent leakage in the crystal oscillator. When an external clock is used as the main system clock, never set SCC.3 to 1.

Cautions 4. When the four bits of the PCC are set to 0001 ($\Phi = f_x/16$), do not set SCC.0 to 1. Before switching the main system clock to the subsystem clock, be sure to manipulate the PCC bits so other than 0001 is set. When the system operates on the subsystem clock, the PCC bits must also be other than 0001.

(3) System clock oscillator

- (i) The main system clock oscillator (6.0 MHz typical) operates with a crystal resonator or ceramic resonator connected to the X1 and X2 pins.

An external clock can also be input. Input the clock signal to the X1 pin and the reversed signal to the X2 pin.

Figure 5-16 shows the external circuit for the main system clock oscillator.

Figure 5-16. External Circuit for the Main System Clock Oscillator

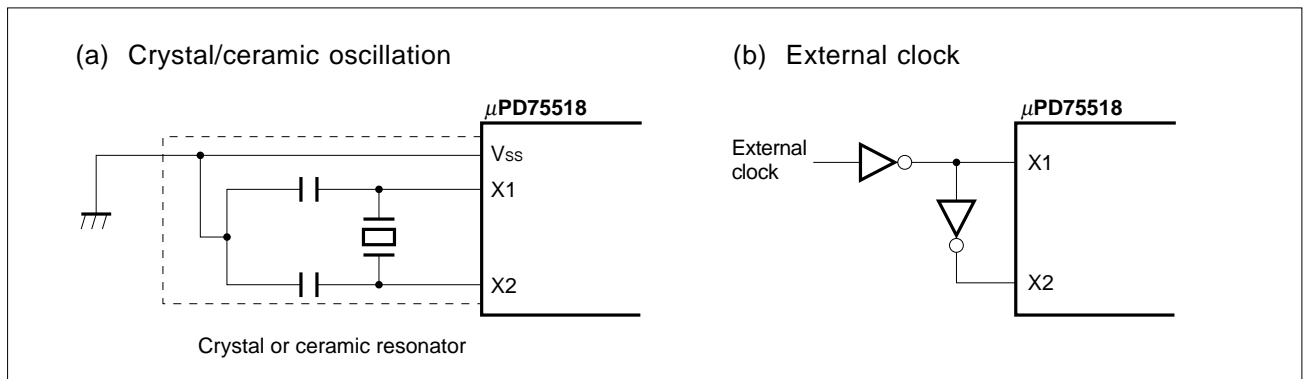

Caution When an external clock is used, the STOP mode cannot be set. This is because the X1 pin is connected to VSS in the STOP mode.

- (ii) The subsystem clock oscillator operates with a crystal resonator (32.768 kHz standard) connected to the XT1 and XT2 pins.

An external clock can also be input. Input the clock signal to the XT1 pin and the reversed signal to the XT2 pin.

Figure 5-17 shows the external circuit for the subsystem clock oscillator.

Figure 5-17. External Circuit for the Subsystem Clock Oscillator

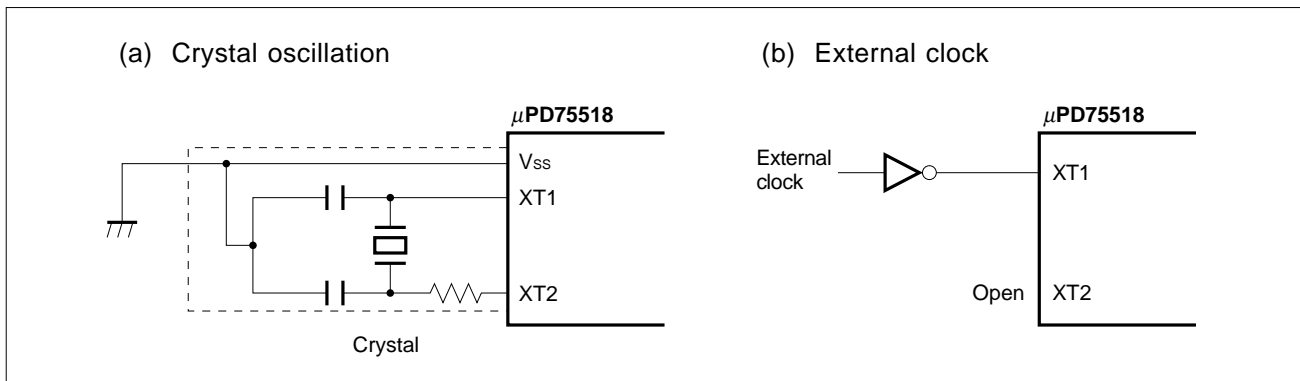

Caution When the main system clock or subsystem clock oscillator is used, conform to the following guidelines when wiring at the shaded portions of Figures 5-16 and 5-17 to eliminate the influence of the stray capacitance around the wiring.

- The wiring must be as short as possible.
- Other signal lines must not run in these areas. Any line carrying a high pulsating current must be kept away as far as possible.
- The grounding point of the capacitor of the oscillator must have the same potential as that of V_{SS} . It must not be grounded to a grounding pattern carrying a high current.
- No signal must be taken directly from the resonator. Take special care of the subsystem clock oscillator because it has low amplification to minimize current consumption.

Figure 5-18 gives examples of oscillator connections which should be avoided.

Figure 5-18. Examples of Oscillator Connections which should be Avoided (1/2)

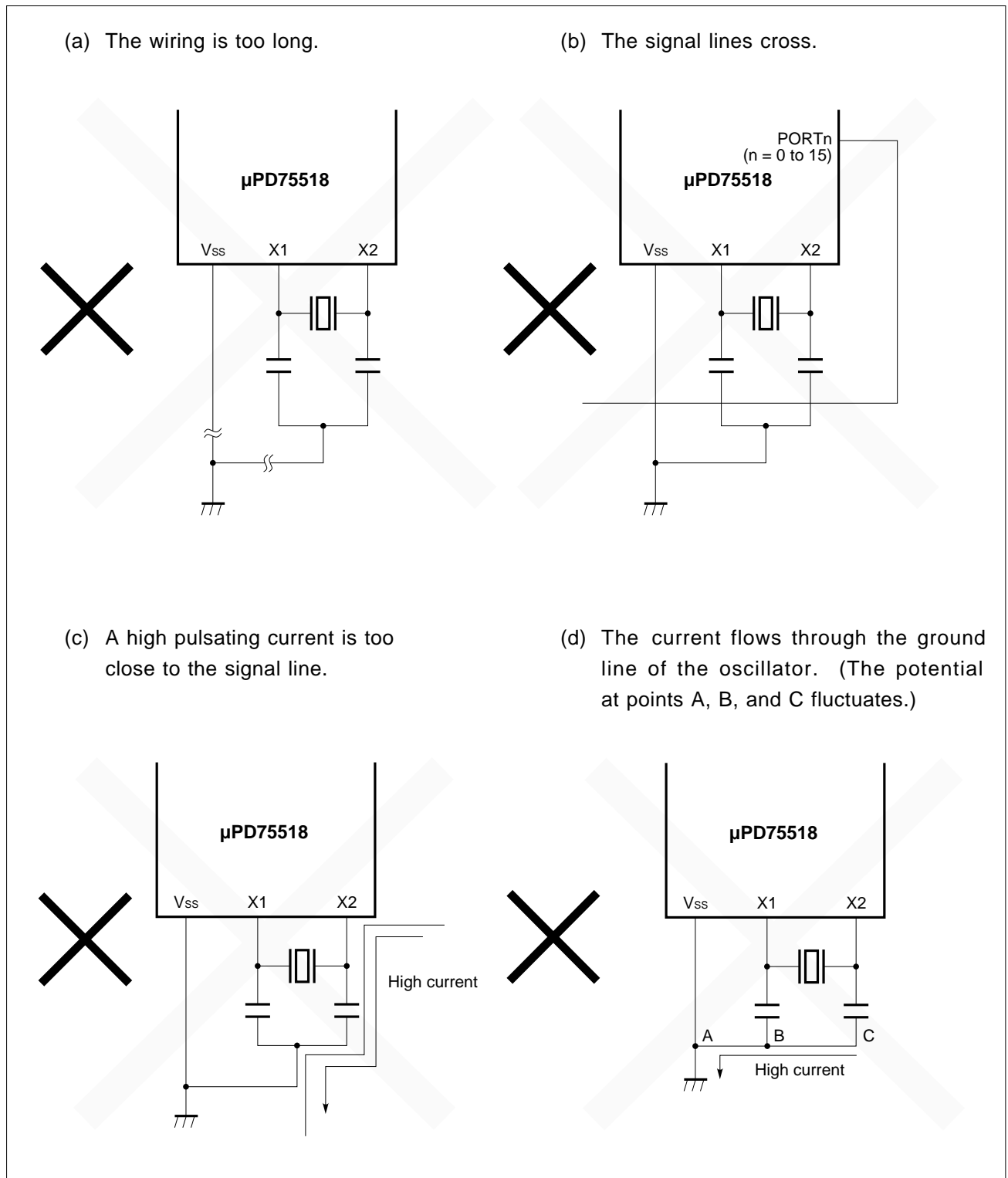

Remark When wiring the subsystem clock, read X1 and X2 as XT1 and XT2 respectively. In this case, a resistor must be added to XT2 in series.

Figure 5-18. Examples of Oscillator Connections which should be Avoided (2/2)

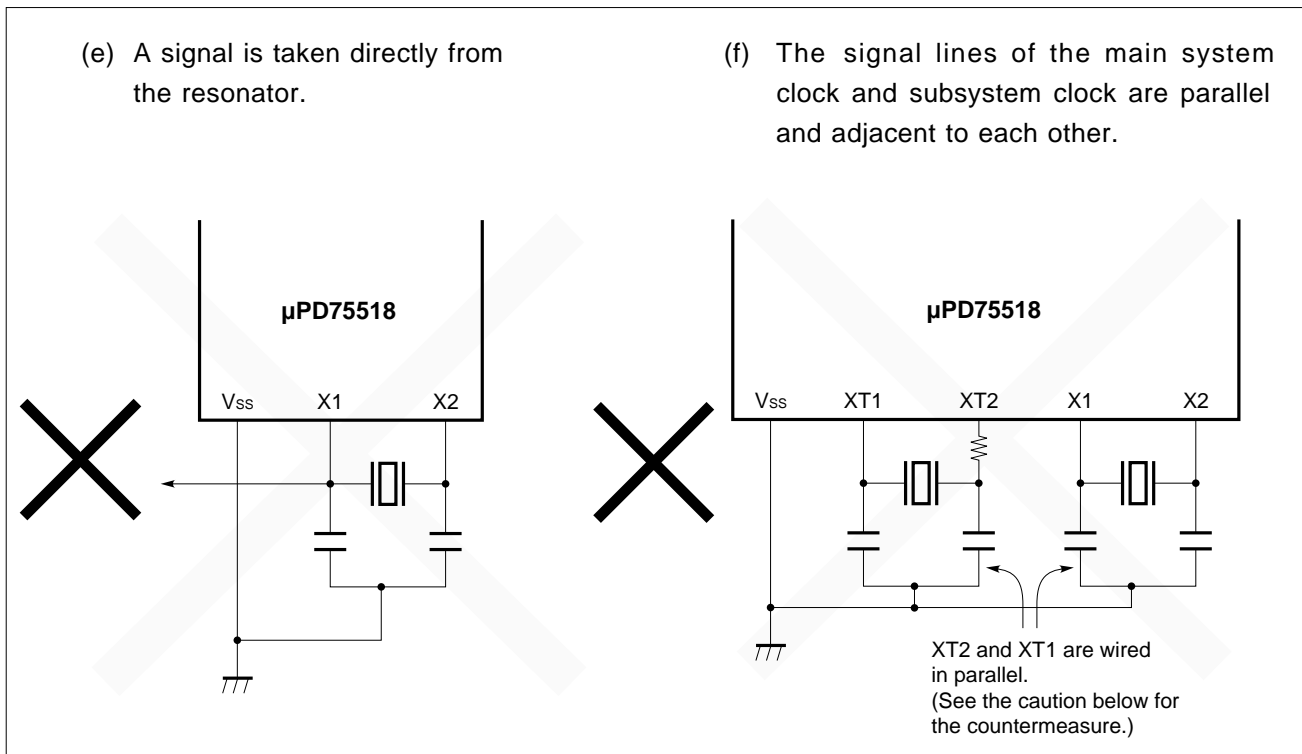

Remark When wiring the subsystem clock, read X1 and X2 as XT1 and XT2 respectively. In this case, a resistor must be added to XT2 in series.

Caution In (f) of Figure 5-18, XT2 and X1 are wired in parallel. This may cause the system to malfunction due to crosstalk noise in XT2 from X1. To prevent this, XT2 and X1 must not be wired in parallel. It is also recommended that the IC pin located between XT2 and X1 be connected to V_{SS}.

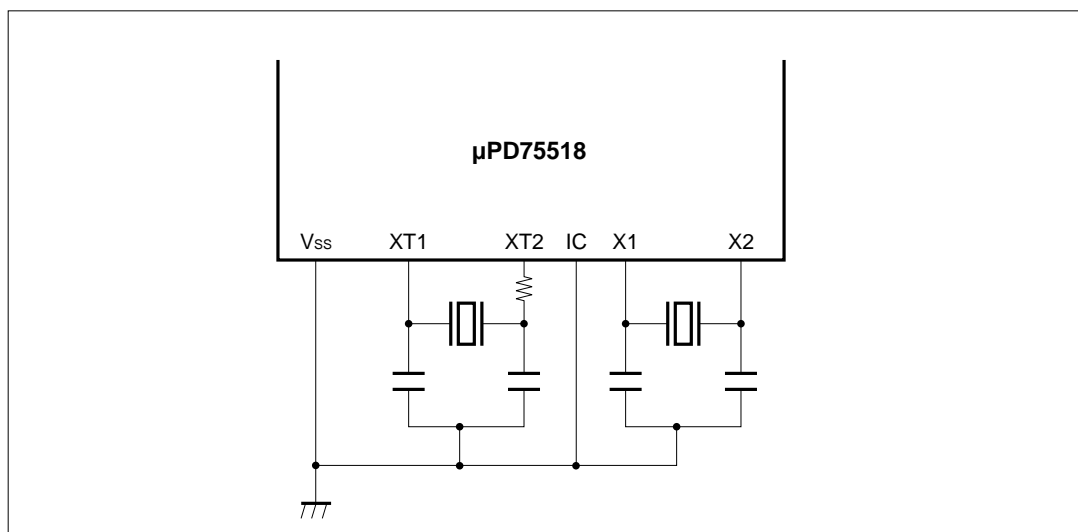

(4) Frequency divider

The frequency divider divides the output (f_x) of the main system clock oscillator to generate various clocks.

(5) Treatment of the subsystem clock pins when not used

If the subsystem clock is not required for low power consumption or clock operation, the XT1 and XT2 pins must be treated as follows:

XT1: Connected to V_{SS} or V_{DD} .

XT2: Open

In these states, however, a little leakage current flows through the internal feedback resistor of the subsystem clock oscillator when the main system clock is stopped. To prevent this, the internal feedback resistor can be disconnected by a mask option. In this case, the XT1 and XT2 pins must also be treated as listed above. (Specify the mask option for the resistor when ordering the LSI device.)

5.2.3 System Clock and CPU Clock Setting

(1) Time required to change the system clock and CPU clock

The system clock and CPU clock can be changed by using the low-order two bits of the PCC and the least significant bit of the SCC. This switching is not performed immediately after the contents of the registers are rewritten, but the system operates with the previous clock for some machine cycles. Accordingly, after this time period, the STOP instruction must be executed or SCC.3 must be set to 1 to terminate main system clock generation.

Table 5-5. Maximum Time Required to Change the System Clock and CPU Clock

Setting before switching			Setting after switching														
SCC	PCC	PCC	SCC0	PCC1	PCC0	SCC0	PCC1	PCC0	SCC0	PCC1	PCC0	SCC0	PCC1	PCC0	SCC0	PCC1	PCC0
0	1	0	0	0	0	0	0	1	0	1	0	0	1	1	1	x	x
0	0	0	/			1 machine cycle			1 machine cycle			1 machine cycle			f _X /64f _{XT} machine cycles (3 machine cycles)		
	0	1				4 machine cycles			4 machine cycles			4 machine cycles			Not to be set		
	1	0				8 machine cycles			8 machine cycles			8 machine cycles			f _X /8f _{XT} machine cycles (23 machine cycles)		
	1	1				16 machine cycles			16 machine cycles			16 machine cycles			f _X /4f _{XT} machine cycles (46 machine cycles)		
1	x	x	1 machine cycle			Not to be set			1 machine cycle			1 machine cycle			/		

- Remarks
1. Time indicated in parentheses is required when f_X = 6.0 MHz and f_{XT} = 32.768 kHz.
 2. x: Don't care
 3. CPU clock Φ is supplied to the CPU. The reciprocal of this frequency is a minimum instruction time (defined as one machine cycle in this manual).

-
- Cautions**
1. When the four bits of the PCC are set to 0001B ($\Phi = f_X/16$), do not set SCC.0 to 1. Before switching the main system clock to the subsystem clock, be sure to manipulate the PCC bits so other than 0001B is set. When the system operates on the subsystem clock, the PCC bits must also be other than 0001B.
 2. The fluctuation of the ambient temperature around an oscillator and the performance of a load capacity change f_X and f_{XT} . In particular, when f_X is higher than the nominal value or f_{XT} is lower than the nominal value, the machine cycles calculated by $f_X/64f_{XT}$, $f_X/8f_{XT}$, and $f_X/4f_{XT}$ in Table 5-5 are longer than the machine cycle calculated by the nominal values of f_X and f_{XT} .
Therefore, the wait time required to change the system clock and CPU clock should be longer than the machine cycle calculated by the nominal values of f_X and f_{XT} .
-

(2) Procedure for changing the system clock and CPU clock

The procedure for changing the system clock and CPU clock is explained using Figure 5-19.

Figure 5-19. Changing the System Clock and CPU Clock

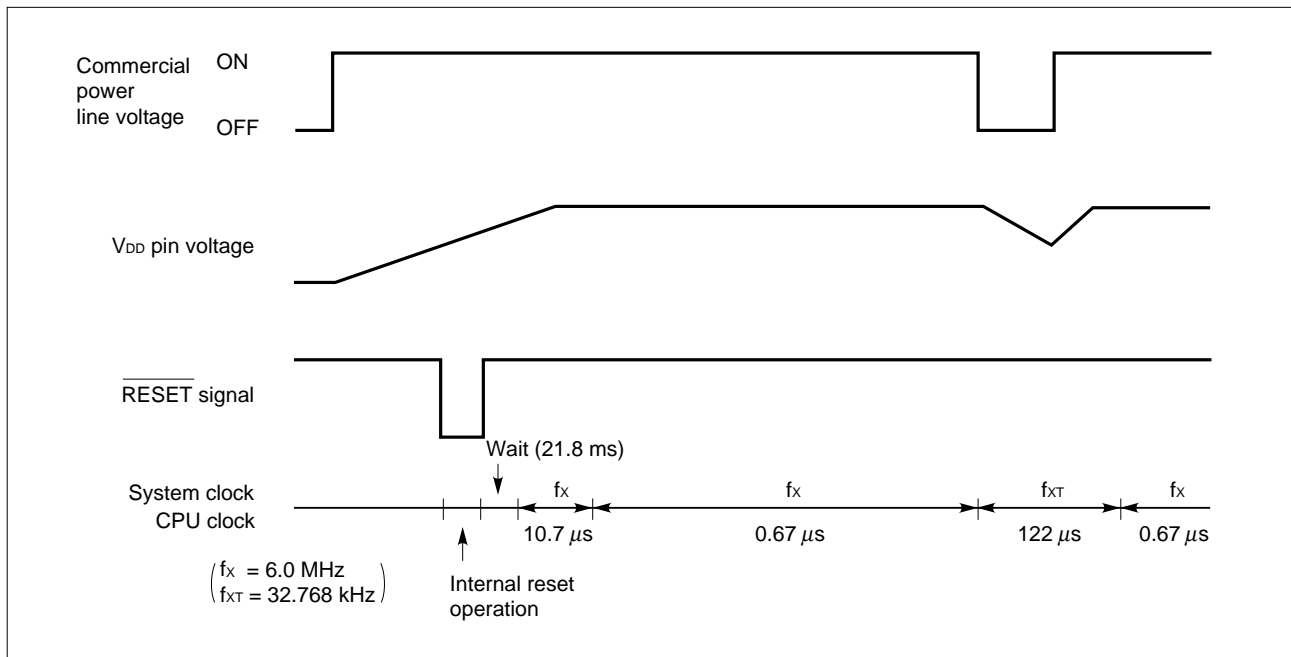

- <1> A $\overline{\text{RESET}}$ signal starts CPU operation at the lowest speed of the main system clock (10.7 μ s: At 6.0 MHz)(Note 1) after a wait time (21.8 ms: At 6.0 MHz)(Note 2) for stable oscillation.
- <2> The PCC is rewritten for highest-speed operation after a time elapse which is sufficient for the voltage on the V_{DD} pin to be high enough for highest-speed operation.
- <3> The removal of commercial power is detected using, for example, an interrupt input(Note 3), then SCC.0 is set to 1 to operate with the subsystem clock. (In this case, subsystem clock generation must have been started.) After a time (32 machine cycles) required to switch to the subsystem clock elapses, SCC.3 is set to 1 to terminate main system clock generation.
- <4> After detecting the input of commercial power by using an interrupt, SCC.3 is cleared to start main system clock generation. After a time required for stable generation, SCC.0 is cleared to 0 to operate at the highest speed.

(Note 1) At 4.19 MHz: 31.3 ms

(Note 2) At 4.19 MHz: 15.3 μ s

(Note 3) INT4 is useful.

5.2.4 Clock Output Circuit

(1) Configuration of the clock output circuit

Figure 5-20 shows the configuration of the clock output circuit.

(2) Functions of the clock output circuit

The clock output circuit outputs a clock pulse signal on the P22/PCL pin to output remote control signals or to supply clock pulses to a peripheral LSI device.

The procedure for outputting a clock pulse signal is as follows:

- (a) Select a clock output frequency, and disable clock output.
- (b) Write a 0 in the P22 output latch.
- (c) Set the output mode for port 2.
- (d) Enable clock output.

Figure 5-20. Configuration of the Clock Output Circuit

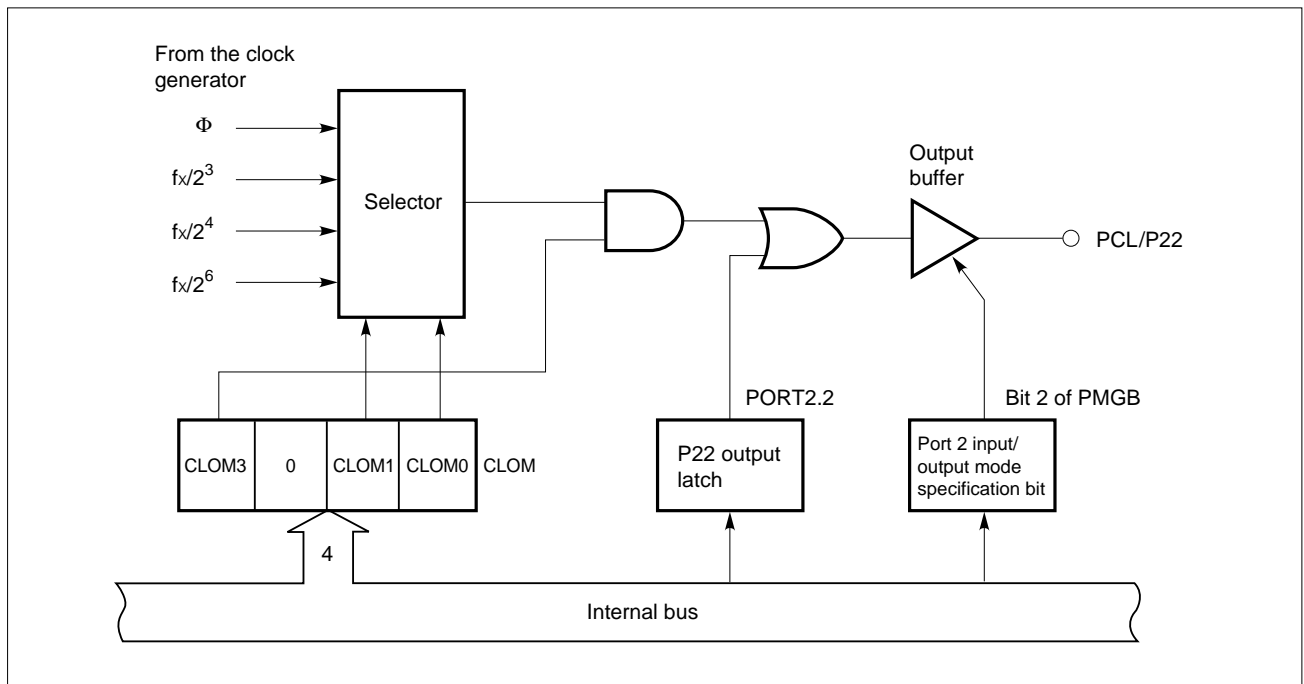

Remark The clock output circuit is designed so that pulses with short widths do not appear in enabling or disabling clock output.

(3) Clock output mode register (CLOM)

The CLOM is a 4-bit register to control clock output.

The CLOM is set by a 4-bit memory manipulation instruction. No read operation is allowed on this register.

A $\overline{\text{RESET}}$ signal clears the CLOM to 0, disabling clock output.

Example CPU clock Φ is output on the PCL/P22 pin.

```
SEL    MB15          ; or CLR1 MBE
MOV    A,#1000B
MOV    CLOM,A
```

Figure 5-21. Format of the Clock Output Mode Register

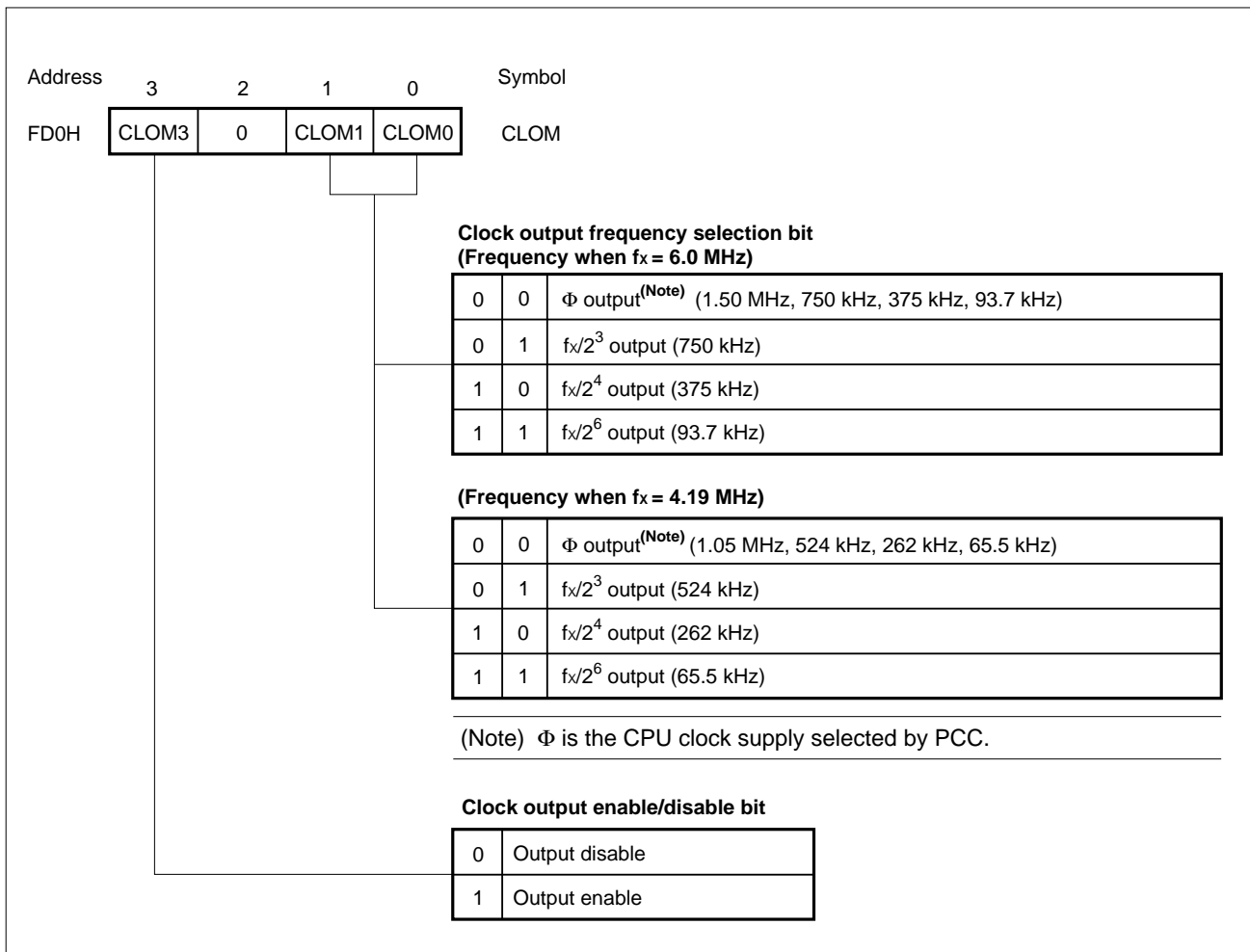

Caution **Be sure to write a 0 in bit 2 of the CLOM.**

(4) Application to remote control output

The clock output function of the μ PD75518 is applicable to remote control output. The frequency of the carrier for remote control output is selected by the clock frequency select bit of the clock output mode register. Pulse output is enabled or disabled by controlling the clock output enable/disable bit by software.

The clock output circuit is designed so that pulses with short widths do not appear in enabling or disabling clock output.

Figure 5-22. Application to Remote Control Output

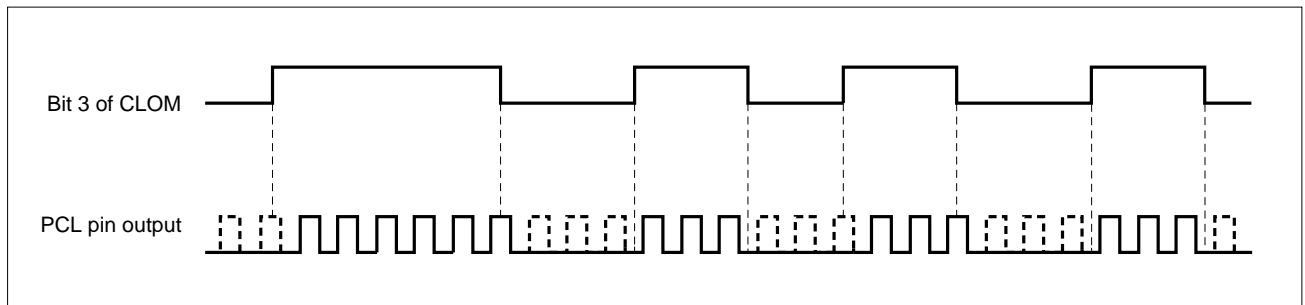

5.3 Basic Interval Timer

The μ PD75518 contains an 8-bit basic interval timer (BT), which has the following functions:

- (a) Reference time generation (four time intervals)
- (b) Use as a watchdog timer for detecting program crashes
- (c) Selection of a wait time for releasing the standby mode, and counting
- (d) Reading the count value

5.3.1 Configuration of the Basic Interval Timer

Figure 5-23 shows the configuration of the basic interval timer.

Figure 5-23. Configuration of the Basic Interval Timer

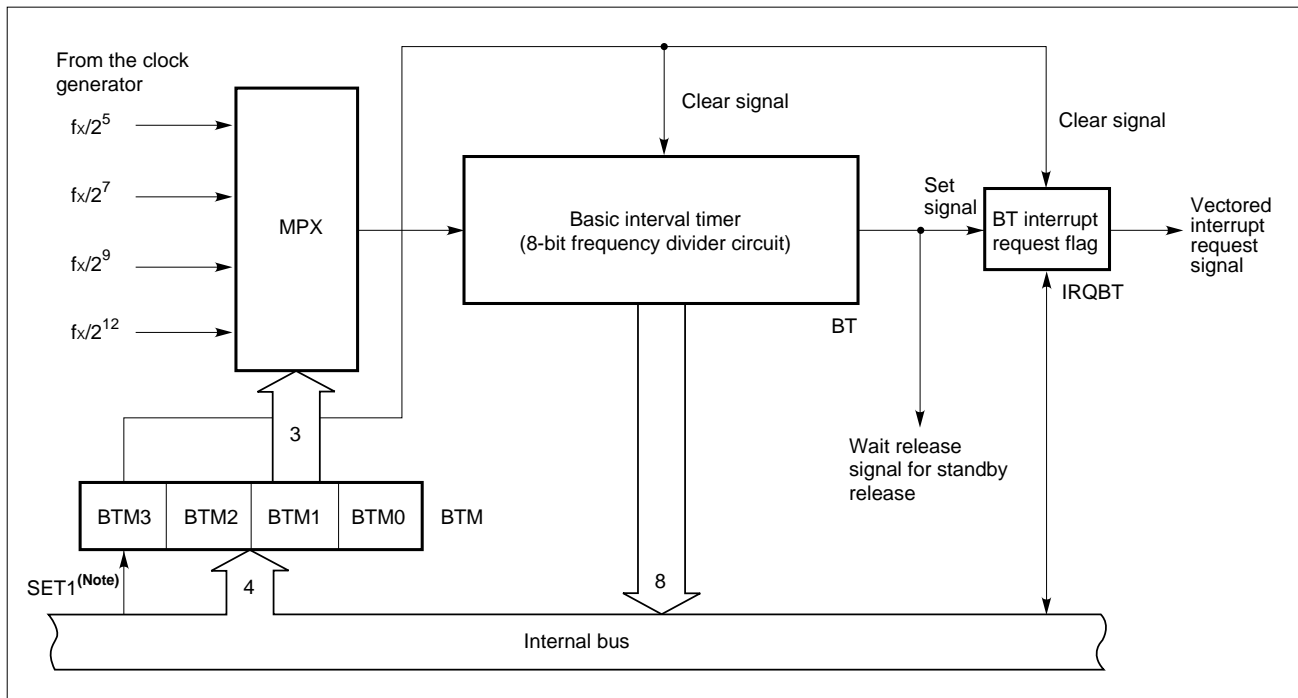

(Note) Instruction execution

5.3.2 Basic Interval Timer Mode Register (BTM)

The BTM is a 4-bit register for controlling operation of the basic interval timer.

A 4-bit memory manipulation instruction is used to set the BTM.

Bit 3 can be independently set using a bit manipulation instruction.

When bit 3 is set to 1, the basic interval timer is cleared, and the basic interval timer interrupt request flag (IRQBT) is also cleared (to start the basic interval timer).

A $\overline{\text{RESET}}$ signal clears the interval timer to 0, and the longest interrupt request signal generation interval time is set.

Example 1. The interrupt generation interval is set to 1.95 ms (at 4.19 MHz).

```
SEL  MB15      ; or CLR1 MBE
MOV  A,#1111B
MOV  BTM,A     ; BTM <- 1111B
```

Example 2. The BT and IRQBT are cleared (to implement a watchdog timer).

```
SEL  MB15      ; or CLR1 MBE
SET1 BTM.3    ; Set bit 3 of BTM to 1
```

Figure 5-24. Format of the Basic Interval Timer Mode Register

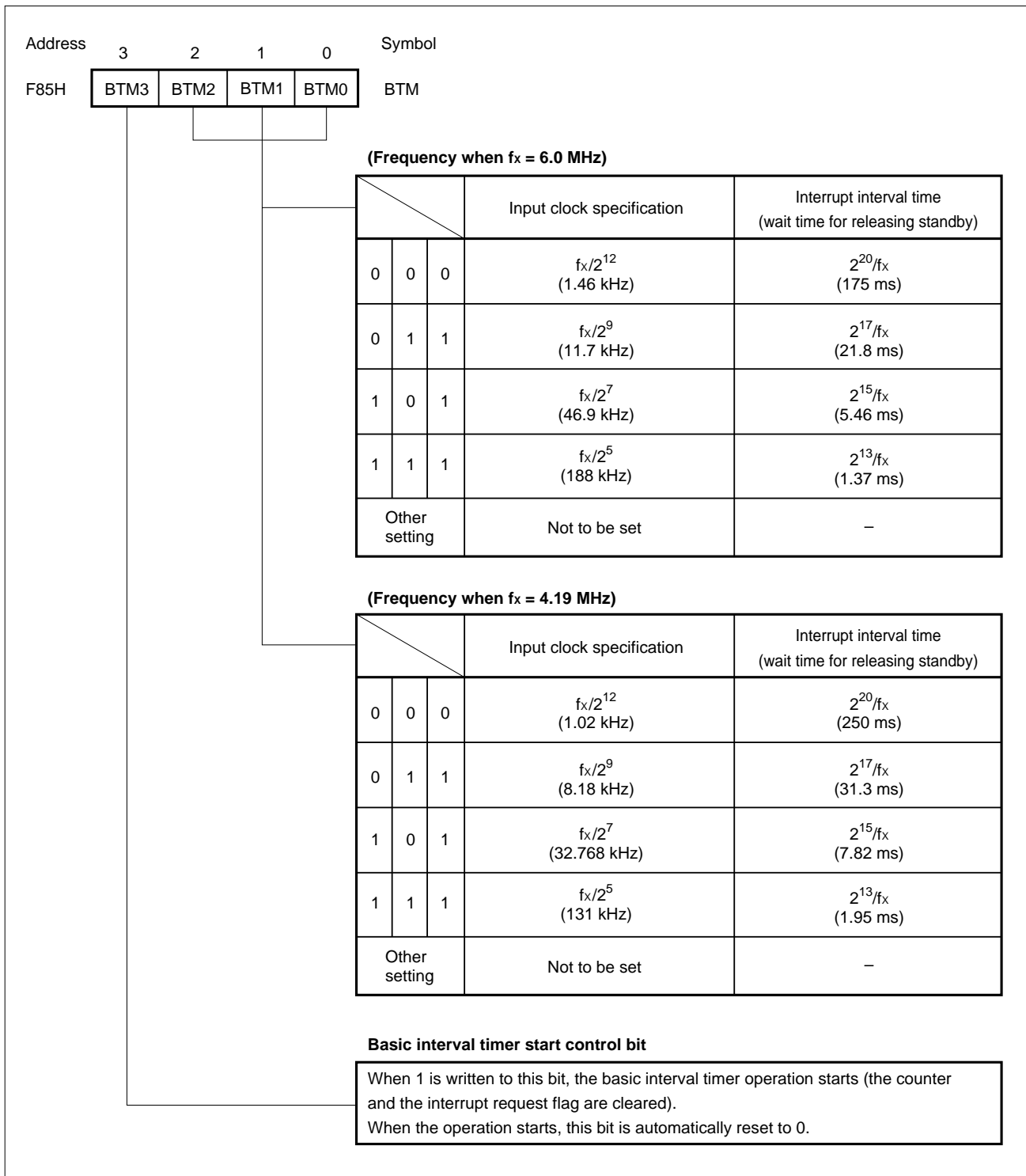

5.3.3 Operation of the Basic Interval Timer

The basic interval timer (BT) is always incremented by the clock supplied from the clock generator, and when it overflows, the interrupt request flag (IRQBT) is set. The count operation of the BT cannot be stopped.

One of four interrupt generation intervals can be selected by setting the BTM. (See **Figure 5-24**.)

The basic interval timer and the interrupt request flag can be cleared by setting bit 3 of the BTM to 1 (instruction for starting as an interval timer).

The count in the BT can be read using an 8-bit manipulation instruction. Writing to the BT is inhibited.

Caution **When reading the count from the BT, execute a read instruction twice so that unstable data being counted will not be read. If two read values are reasonable, use the second one as the result. If two read values are far apart from each other, retry all over again.**

Example The count in the BT is read.

```

                SET1    MBE
                SEL     MB15
                MOV     HL,#BT    ; Set the address of BT in HL
LOOP : MOV     XA,@HL    ; First read
                MOV     BC,XA
                MOV     XA,@HL    ; Second read
                SKE     XA,BC
                BR      LOOP

```

To obtain a time required for stable system clock generation in releasing the STOP mode, a wait function is available which stops the operation of the CPU until the basic interval timer overflows.

The wait time is fixed after a $\overline{\text{RESET}}$ signal is generated. On the other hand, a wait time can be selected by setting the BTM when the STOP mode is released with an interrupt occurrence. In this case, possible wait times are the same as the interval times shown in **Figure 5-24**. The BTM must be set before the STOP mode is set. (See **Chapter 7** for details.)

5.3.4 Application Examples of the Basic Interval Timer

Example 1. A basic interval timer interrupt is enabled, and an interrupt generation interval of 1.95 ms (when a clock of 4.19 MHz is used) is set.

```
SEL    MB15
MOV    A,#1111B
MOV    BTM,A      ; Setting and start
EI                      ; Enable an interrupt
EI    IEBT       ; Enable a BT interrupt
```

Example 2. Use as a watchdog timer

A program is divided into modules each of which can be executed within the time set in the BT, and the BT and the interrupt request flag (IRQBT) are cleared when the execution of each module is completed. If an interrupt occurs, it is treated as a crash. Set an interrupt occurrence interval to 7.8 ms (at 4.19 MHz) and divide a program into modules so that the execution time of each module is less than 7.8 ms.

```
Initialization
SEL    MB15
MOV    A,#1101B   ; or CLR1 MBE
MOV    BTM,A     ; Setting and start
EI
EI    IEBT
```

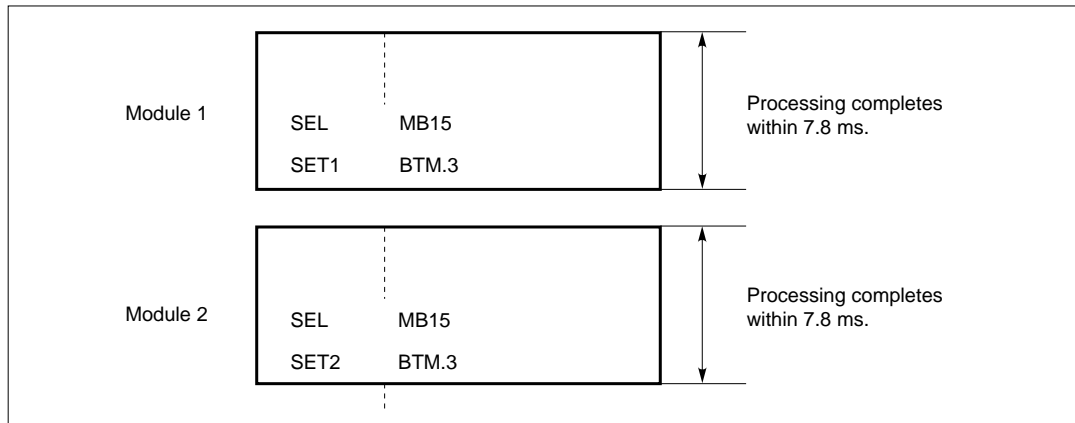

Example 3. A wait time of 7.8 ms (at 4.19 MHz) is set for releasing the STOP mode with an interrupt.

```
SEL    MB15
MOV    A,#1101B
MOV    BTM,A     ; BTM <- 1101B
STOP                      ; Set STOP mode
NOP
```

Example 4. The high level width of pulses applied to the INT4 interrupt pin (both edges detected). (The pulse width is assumed not to exceed the value set in the BT. The set value in the BT is 7.8 ms or longer.)

<INT4 interrupt routine (MBE = 0)>

```
LOOP : MOV      XA,BT      ; First read
        MOV      BC,XA     ; Store data
        MOV      XA,BT     ; Second read
        SKE      A,C
        BR       LOOP
        MOV      A,X
        SKE      A,B
        BR       LOOP
        SKT      PORT0.0   ; P00 = 1?
        BR       AA        ; NO
        MOV      XA,BC     ; Store data in data memory
        MOV      BUFF,XA
        CLR1     FLAG      ; Data present, clear the flag
        RETI
AA :    MOV      HL,#BUFF
        MOV      A,C
        SUBC     A,@HL
        INCS     L
        MOV      C,A
        MOV      A,B
        SUBC     A,@HL
        MOV      B,A
        MOV      XA,BC
        MOV      BUFF,XA   ; Store data
        SET1     FLAG      ; Data present, set the flag
        RETI
```

5.4 Clock Timer

The μ PD75518 contains one clock timer, which has the following functions.

- (a) The clock timer sets the test flag (IRQW) every 0.5 seconds.
The IRQW can release the standby mode.
- (b) Either the main system clock or the subsystem clock can be used to produce 0.5-second intervals.
- (c) The fast-forward mode produces an interval 128 times faster (3.91 ms), which is useful for program debugging and testing.
- (d) A fixed frequency (2.048 kHz) can be output to P23/BUZ, so that it can be used for sounding the buzzer and for system clock frequency trimming.
- (e) The frequency divider can be cleared to start the clock from zero second.

5.4.1 Configuration of the Clock Timer

Figure 5-25 shows the configuration of the clock timer.

Figure 5-25. Block Diagram of the Clock Timer

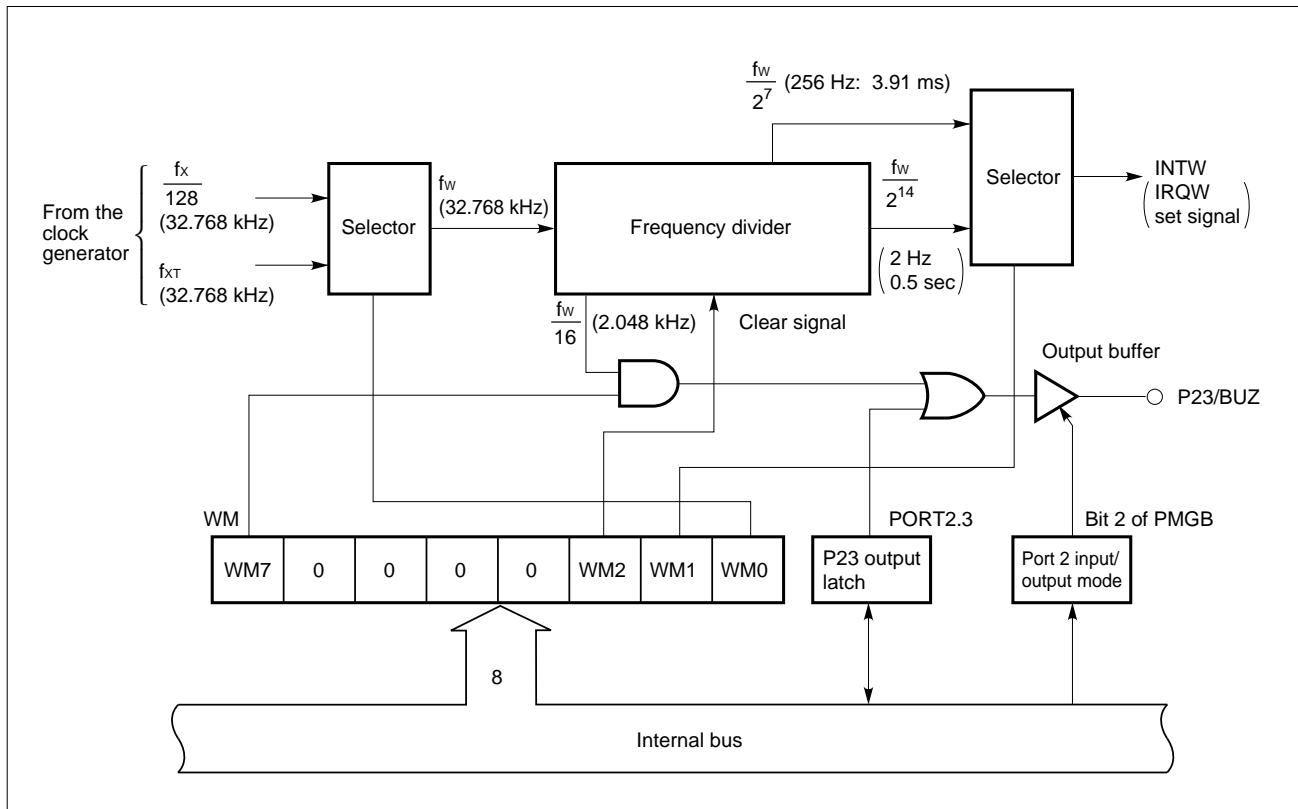

The values in parentheses are for $f_x = 4.194304$ MHz and $f_{XT} = 32.768$ kHz.

5.4.2 Watch Mode Register

The watch mode register (WM) is an 8-bit register for controlling the clock timer. Figure 5-26 shows its format.

An 8-bit memory manipulation instruction is used to set the watch mode register.

A $\overline{\text{RESET}}$ signal clears all bits to 0.

Example Time is set using the main system clock (4.19 MHz), and buzzer output is enabled.

```

CLR1    MBE
MOV     XA,#84H
MOV     WM,XA    ; Set WM
    
```

Figure 5-26. Format of the Watch Mode Register

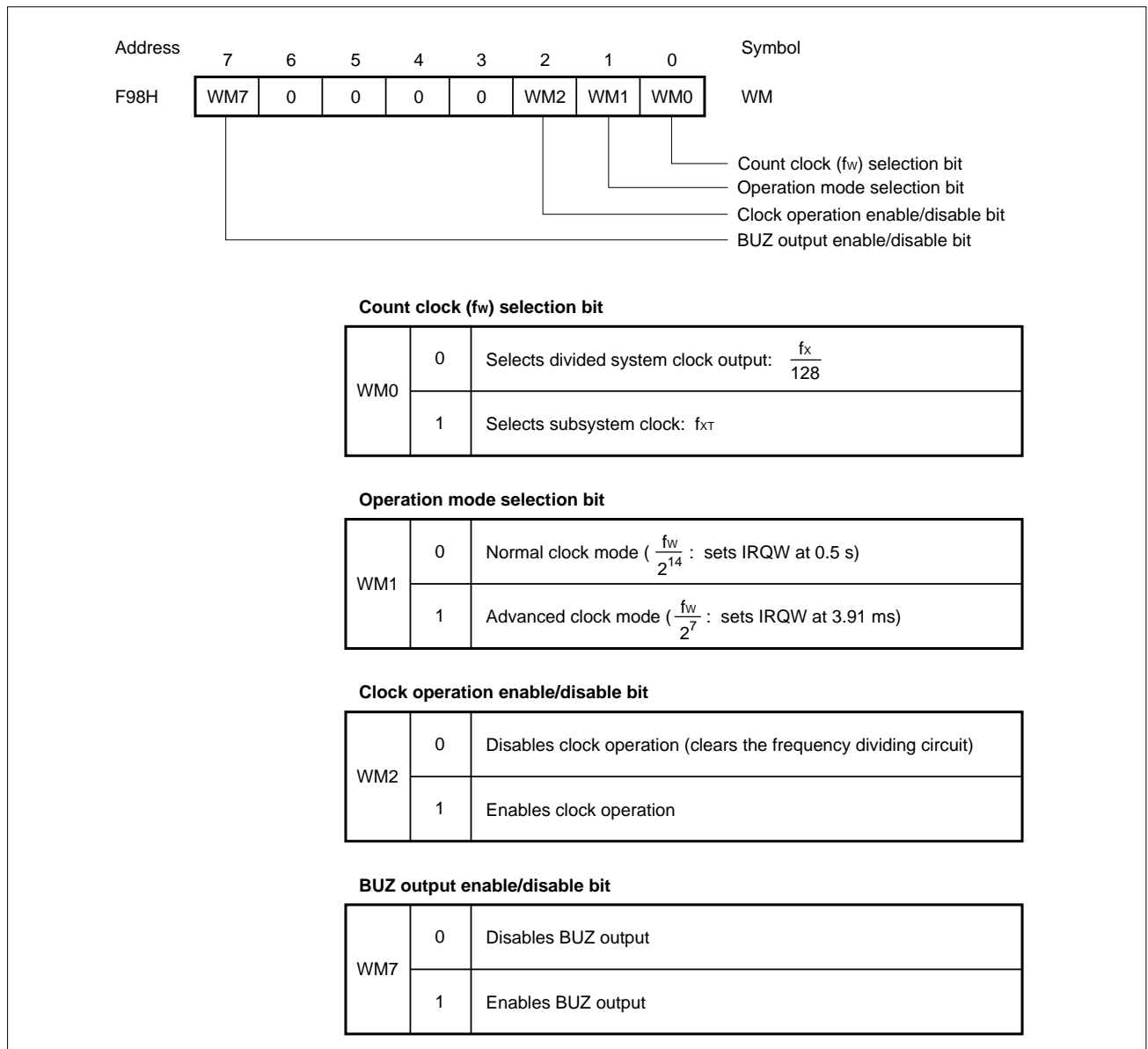

5.5 Timer/Event Counter

5.5.1 Configuration of the Timer/Event Counter

The μ PD75518 contains one timer/event counter. Figure 5-27 shows the configuration.

The timer/event counter has the following functions.

- (a) Programmable interval timer operation
- (b) Output of a square wave at a given frequency to the PTO0 pin
- (c) Event counter operation
- (d) Frequency divider operation that divides an input to the TIO pin by N and outputs the result to the PTO0 pin
- (e) Supply of the serial shift clock signal to a serial interface circuit
- (f) Function of reading the state of counting

Figure 5-27. Block Diagram of the Timer/Event Counter

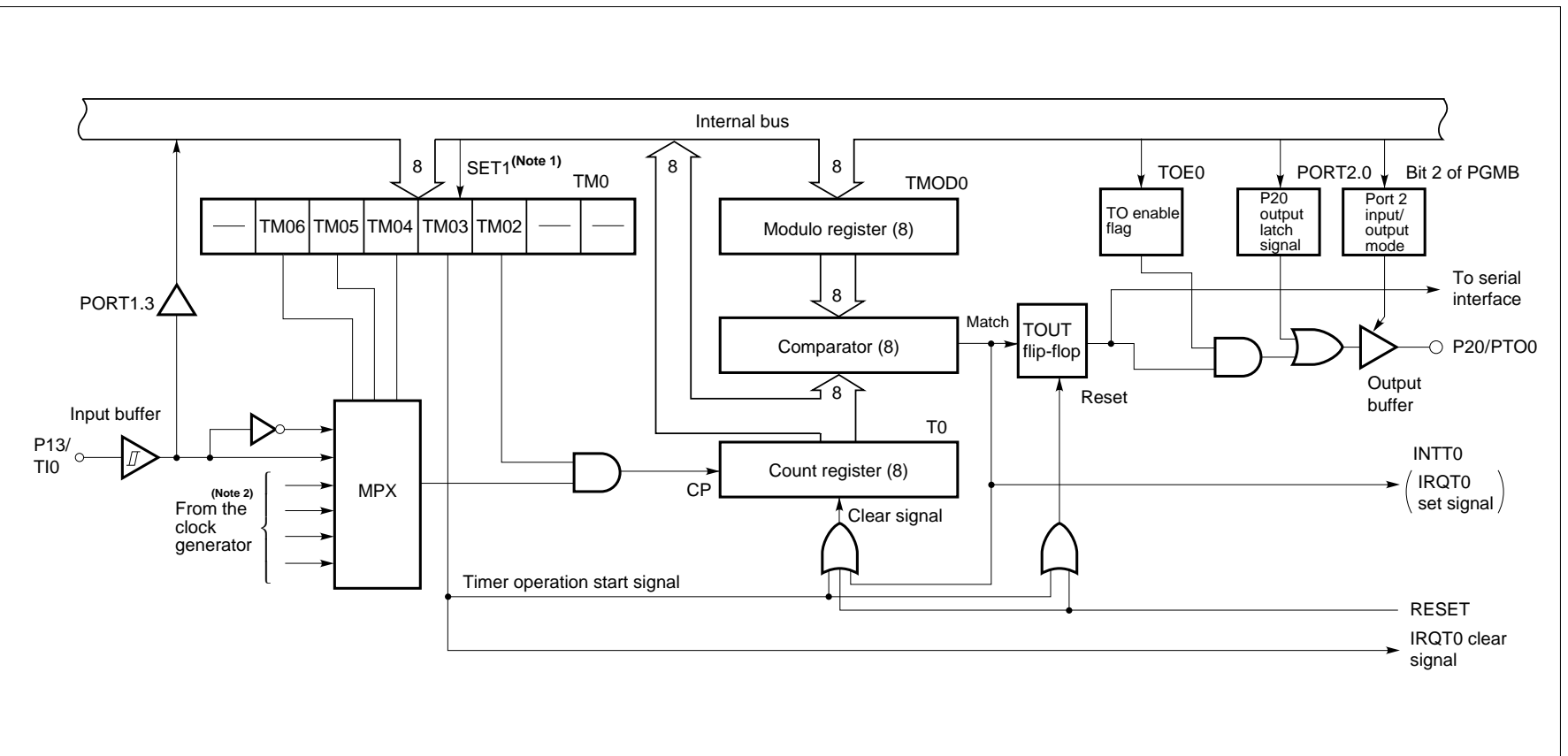

(Note 1) Instruction execution
 (Note 2) See Figure 5-13.

5.5.2 Basic Configuration and Operation of the Timer/Event Counter

The timer/event counter has several operation modes. A mode can be selected by the timer/event counter mode register (TM0). The basic configuration and operation of the timer/event counter are described below.

- (1) The count pulse (CP) is selected by setting TM0, and is set in the 8-bit count register (T0).
- (2) T0 is a binary 8-bit up-counter incremented by one each time the CP is applied. T0 is cleared to 0 when a $\overline{\text{RESET}}$ signal is generated, bit 3 of TM0 is set (to start the timer), or a match signal occurs. T0 can be read at any time with an 8-bit memory manipulation instruction, but cannot be written to.
- (3) The modulo register (TMOD0) is an 8-bit register for determining the count of T0. A value can be set in TMOD0 with an 8-bit memory manipulation instruction, but cannot be read. A $\overline{\text{RESET}}$ signal initializes TMOD0 to FFH.
- (4) The comparator compares the contents of T0 with the contents of TMOD0. If they match, the comparator generates a match signal, and sets the interrupt request flag (IRQT0).

Figure 5-28 shows the timing of count operation.

Figure 5-28. Timing of Count Operation

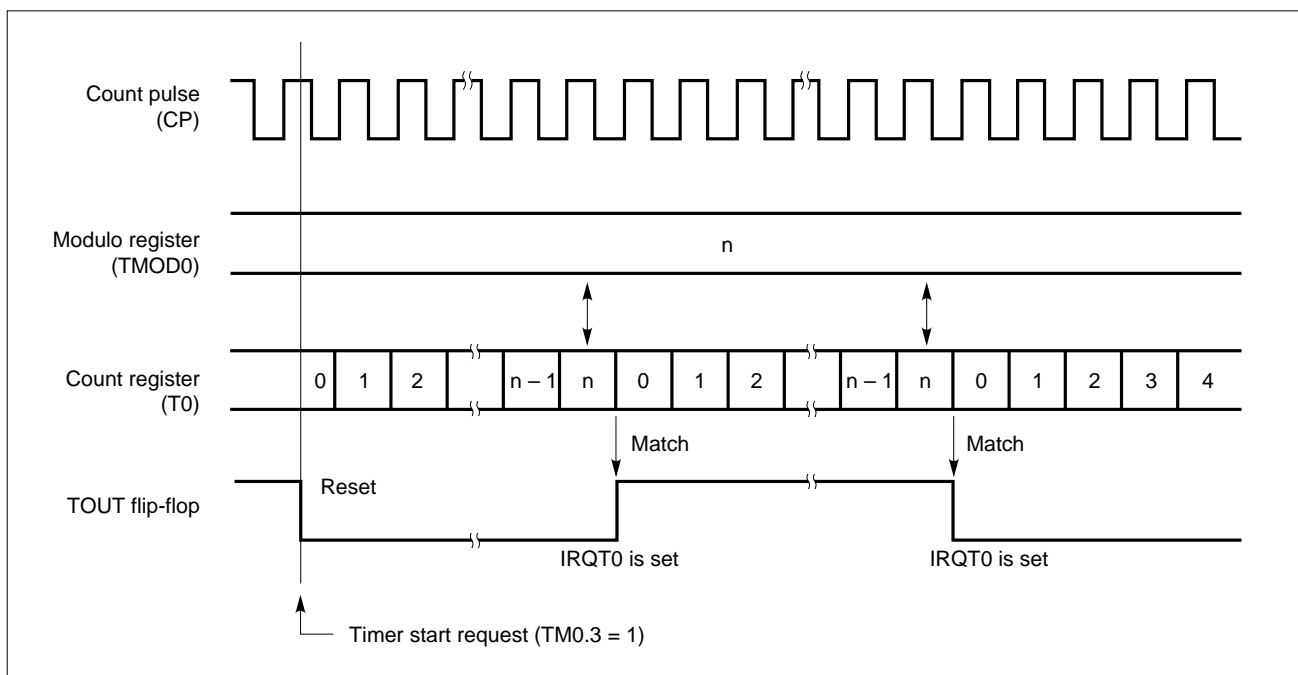

5.5.3 Timer/Event Counter Mode Register (TM0)

The timer/event counter mode register (TM0) is an 8-bit register for controlling the timer/event counter. Figure 5-29 shows its format.

An 8-bit memory manipulation instruction is used to set the timer/event counter mode register.

Bit 3 is the timer start bit, and can be set independently of the other bits. Bit 3 is automatically reset to 0 when the timer starts operation.

A $\overline{\text{RESET}}$ signal clears all the bits of the timer mode register to 0.

Example 1. The timer is started in the interval timer mode with CP = 4.09 kHz.

```
SEL    MB15          ; or CLR1 MBE
MOV    XA,#01001100B
MOV    TM0,XA        ; TM0 <- 4CH
```

Example 2. The timer is restarted according to the setting of the timer mode register.

```
SEL    MB15          ; or CLR1 MBE
SET1   TM0.3         ; TM0.bit3 <- 1
```

Figure 5-29. Format of the Timer/Event Counter Mode Register

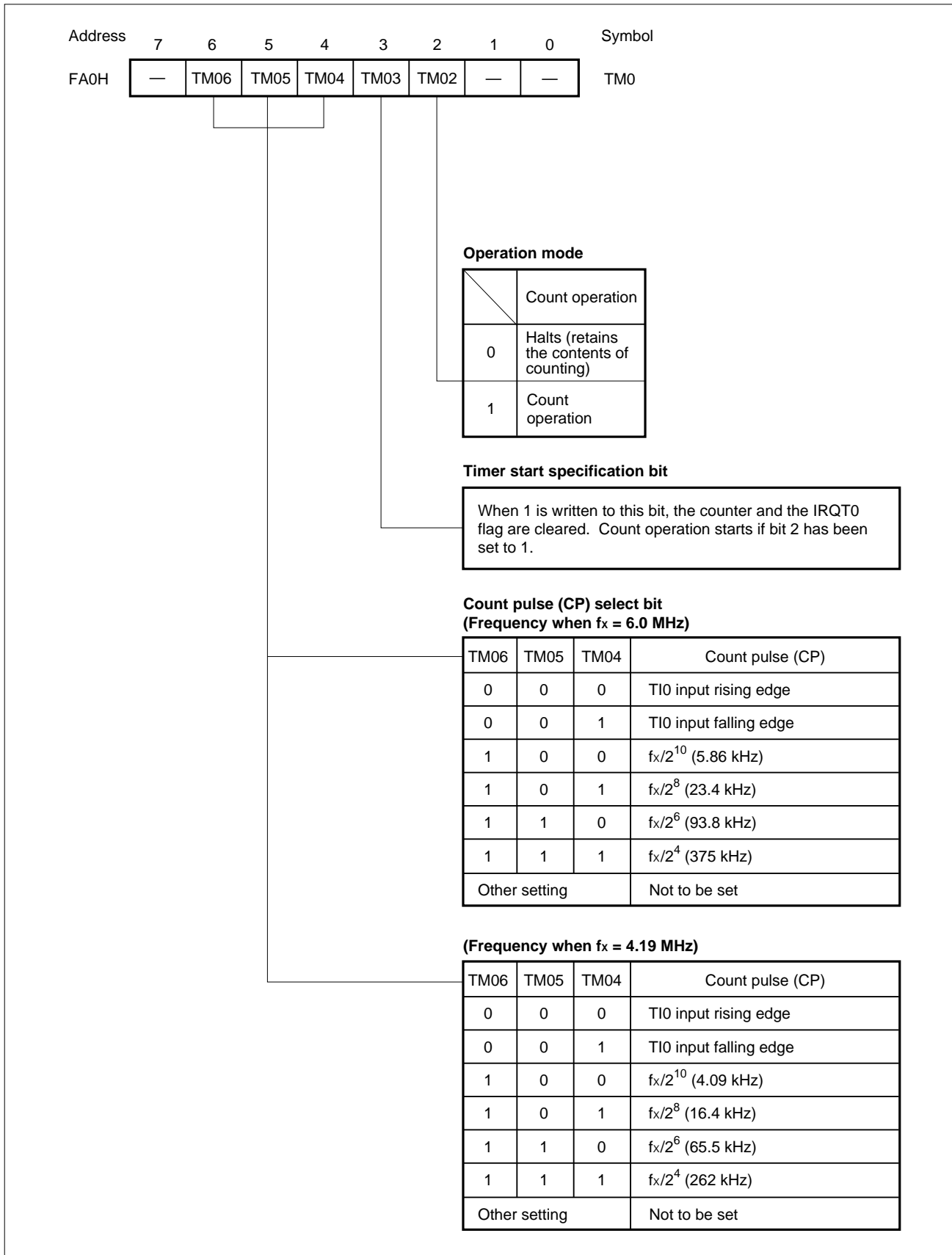

5.5.4 Timer/Event Counter Output Enable Flag (TOE0)

The timer/event counter output enable flag (TOE0) enables or disables output of the time-out flip-flop (TOUT flip-flop) status to the PTO0 pin.

The time-out flip-flop is inverted by a match signal received from the comparator. The time-out flip-flop is reset to 0 when bit 3 of the timer mode register (TM0) is set to 1.

A $\overline{\text{RESET}}$ signal clears the TOE0 and the TOUT flip-flop to 0.

Figure 5-30. Format of the Timer/Event Counter Output Enable Flag

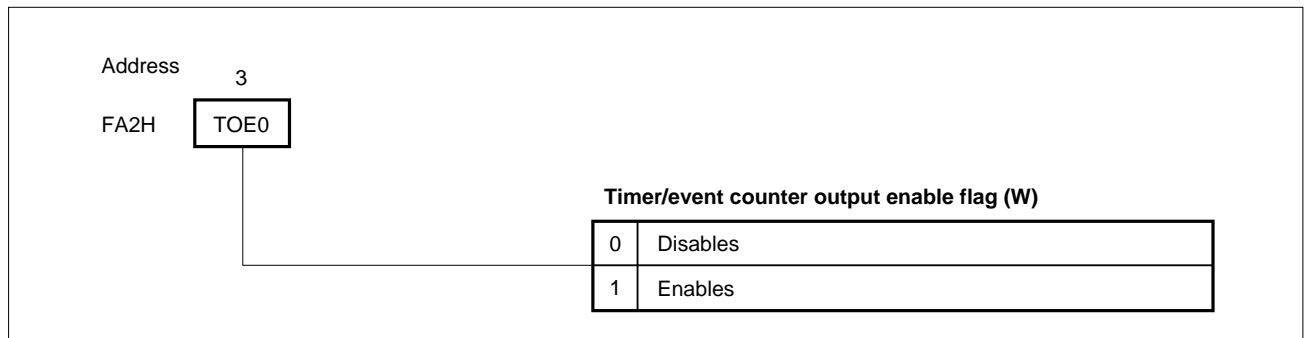

5.5.5 Operation Mode of the Timer/Event Counter

The timer/event counter operates in the count operation disable mode or in the count operation mode, depending on the setting of the mode register.

The following operations are possible, regardless of the setting of the mode register:

- <1> TIO pin signal input and test (input test is possible for the other function (P13) of the pin)
- <2> Output of the time-out flip-flop status to the PTO0(Note)
- <3> Setting of the modulo register (TMOD0)
- <4> Reading from the count register (T0)
- <5> Setting, clearing, and testing of the interrupt request flag (IRQT0)

(Note) When the timer/event counter output pin (PTO0) is used, set dual-purpose the P20 pin as shown below:

- <1> Clear the output latch for P20.
- <2> Set port 2 to the output mode.
- <3> Cancel the use of pull-up resistor for port 2.

(1) Count operation disable mode

This mode is set when bit 2 of TM0 is set to 0. In this mode, count operation is not performed because count pulse (CP) supply to the count register is stopped.

(2) Count operation mode

This mode is set when bit 2 of TM0 is set to 1. In this mode, a count pulse signal selected with bits 4 to 6 is supplied to the count register for count operation as shown in Figure 5-28.

Timer operation is usually started by the following operations:

<1> A count value is set in the modulo register (TMOD0).

<2> An operation mode, count clock, and start instruction are set in the mode register (TM0).

An 8-bit data transfer instruction is used to set the modulo register.

Caution **A value other than 0 must be set in the modulo register.**

Example The value 3FH is set in the modulo register of channel 0.

```
SEL    MB15      ; or CLR1 MBE
MOV    XA,#3FH
MOV    TMOD0,XA
```

Figure 5-31. Operation in the Count Operation Mode

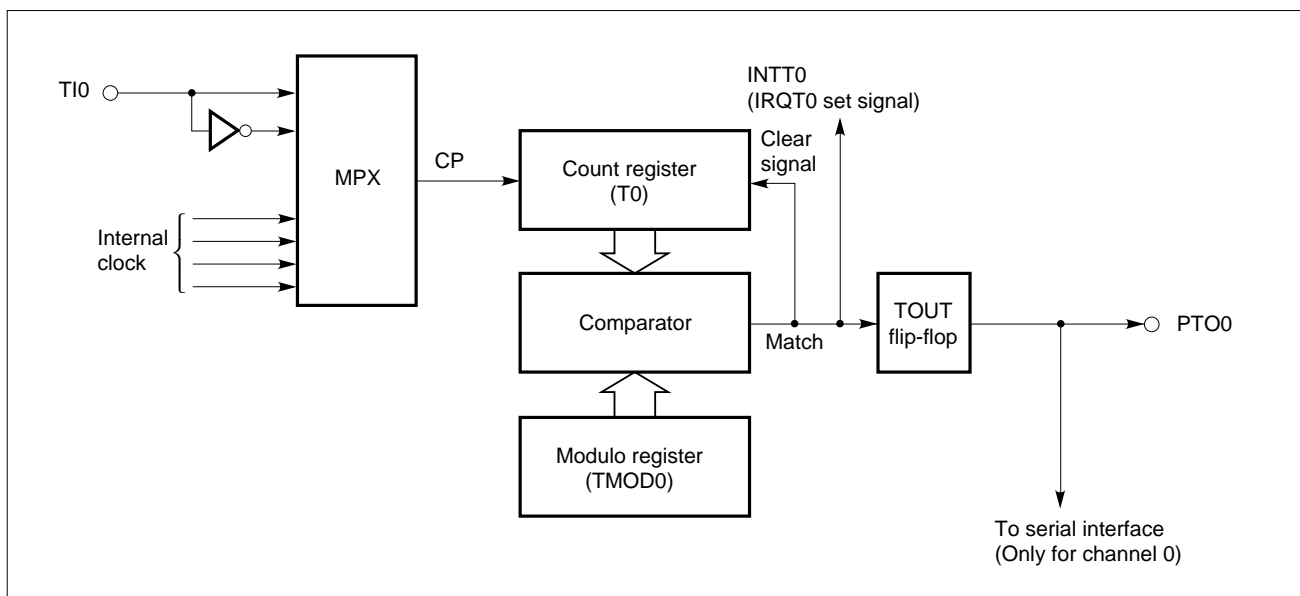

5.5.6 Time Setting in the Timer/Event Counter

[Timer set time](period) is [value of the modulo register + 1] divided by [count pulse frequency] selected by the timer mode register.

$$T(\text{SEC}) = (n + 1)/f_{\text{CP}} = (n + 1) \cdot (\text{resolution})$$

T(SEC) : Timer set time (seconds)

f_{CP} (Hz) : Count pulse frequency (Hz)

n : Value in the modulo register ($n \neq 0$)

Once the timer is set, the interrupt request signal (IRQT0) is generated at set time intervals.

Table 5-6 indicates the resolution and maximum set time (set when FFH is set in the modulo register) of the timer/event counter for each count pulse signal.

Example A time interval of 30 ms is produced ($f_X = 4.194304$ MHz).

In this case, the mode with a maximum set time of 62.5 ms is used.

$$30 \text{ ms}/244 \mu\text{s} = 123 \approx 7\text{BH}$$

Accordingly, 7AH is set in the modulo register.

```
SEL    MB15
```

```
MOV    XA,#7AH
```

```
MOV    TMOD0,XA
```

Table 5-6. Resolution and Maximum Set Time**(When $f_x = 6.0$ MHz)**

Mode register			Timer channel 0	
TM06	TM05	TM04	Resolution	Maximum set time
1	0	0	171 μ s	43.7 ms
1	0	1	42.7 μ s	10.9 ms
1	1	0	10.7 μ s	2.73 ms
1	1	1	2.67 μ s	683 μ s

(When $f_x = 4.19$ MHz)

Mode register			Timer channel 0	
TM06	TM05	TM04	Resolution	Maximum set time
1	0	0	244 μ s	62.5 ms
1	0	1	61.1 μ s	15.6 ms
1	1	0	15.3 μ s	3.91 ms
1	1	1	3.81 μ s	977 μ s

5.5.7 Notes on Timer/Event Counter Applications

(1) Time error at the start of the timer

A maximum error of one count pulse (CP) cycle from a value calculated according to **Section 5.5.6** occurs in a time period from the start of the timer ($TM0.3 = 1$) to the generation of a match signal. This is because the count register is cleared not in phase with the CP as shown in Figure 5-32.

Figure 5-32. Error at the Start of the Timer

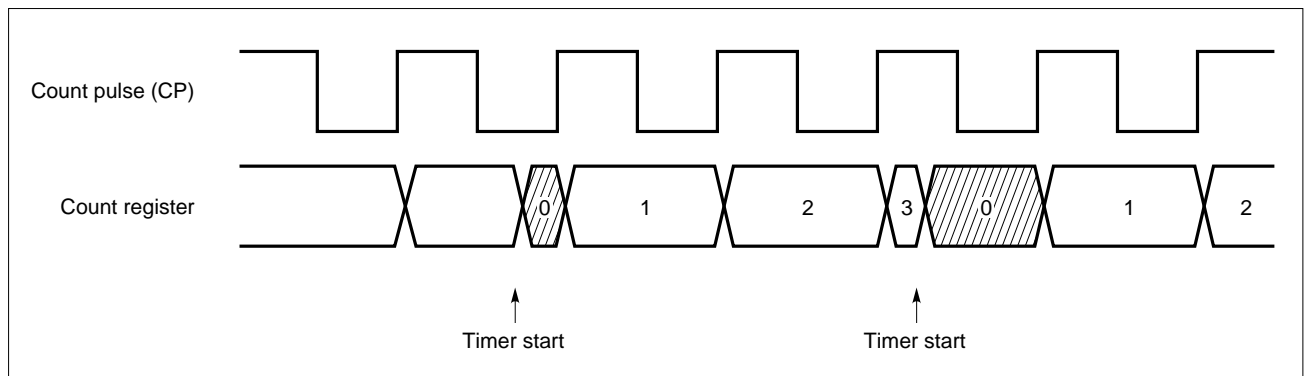

(2) Notes on the start of the timer

Usually, when the timer is started ($TM0.3 = 1$), the count register (T0) and the interrupt request flag (IRQT0) are cleared. However, when the timer is placed in the operation mode, and the setting of IRQT0 and the start of the timer occur at the same time, IRQT0 may not be cleared. This causes no problem if IRQT0 is used for a vectored interrupt. However, if IRQT0 is being tested, a problem arises because IRQT0 is set even if the timer is started. Accordingly, in a situation where the timer is started on such timing that IRQT0 may be set, the timer must be restarted after it is once stopped ($TM0.2 = 0$), or timer start operation must be performed twice.

Example The timer is started on such timing that IRQT0 may be set.

```

SEL    MB15
MOV    XA,#0
MOV    TM0,XA    ; Stop the timer
MOV    XA,#4CH
MOV    TM0,XA    ; Restart
or
SEL    MB15
SET1   TM0.3
SET1   TM0.3    ; Restart
    
```

(3) Error in reading the count register

The contents of the count register can be read using an 8-bit data memory manipulation instruction at any time. During operation by such an instruction, all count pulse changes are held not to change the count register. This means that if the count pulse signal source is applied to the TIO input, as many count pulses as corresponding to the time required to execute the instruction are cut. (When an internal clock is used for the count pulse signal, this problem does not occur because of synchronization with the instruction.)

Accordingly, in an attempt to read the contents of the count register with a count pulse signal applied to TIO, the signal must have a pulse wide enough to avoid incorrect counting even if count pulses are cut. That is, the contents of the count register are held by a read instruction for one machine cycle, so that a signal applied to the TIO pin must have a pulse wider than that.

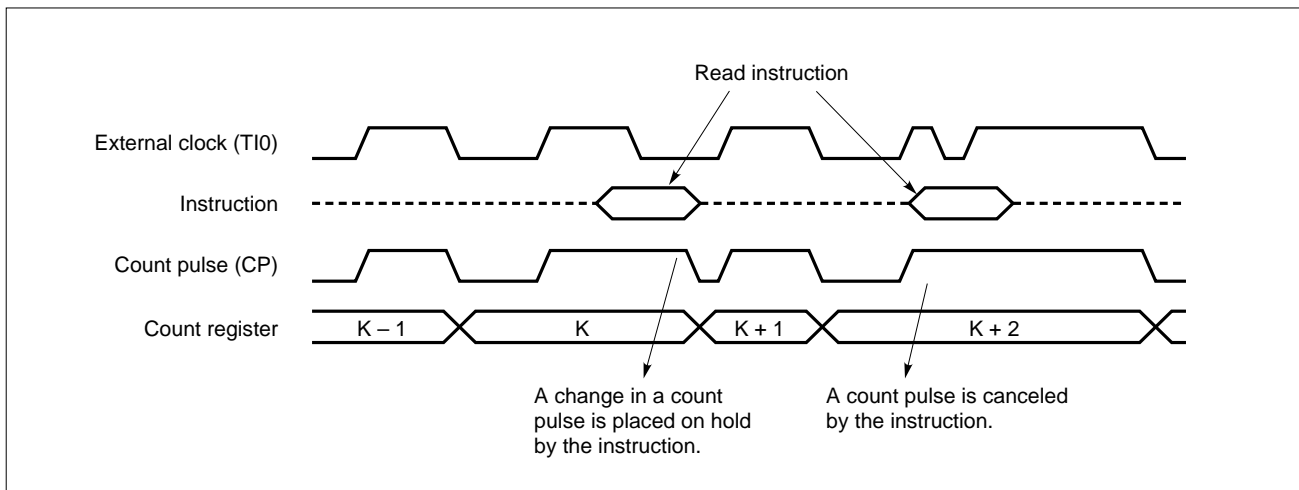

(4) Notes on changing the count pulse

When the count pulse is changed by rewriting the contents of the timer mode register, this takes effect immediately after the rewrite instruction is executed.

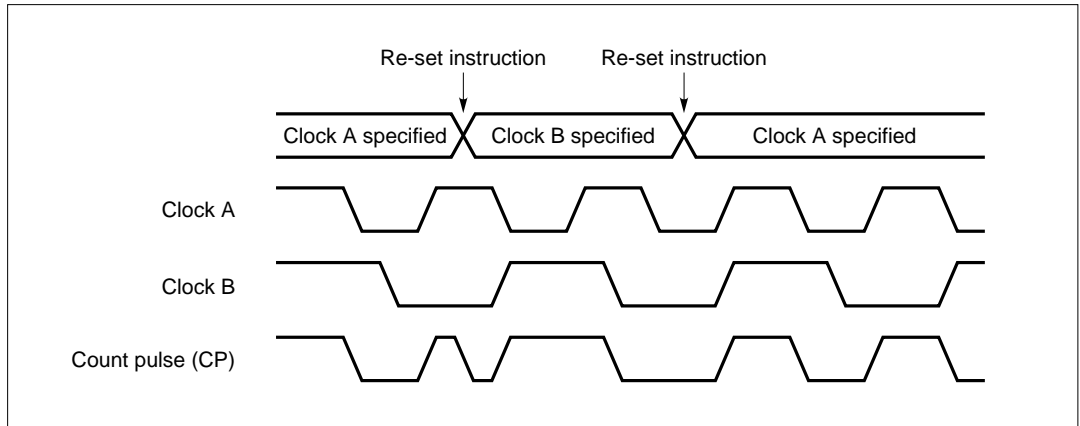

A combination of clocks used for changing count pulse signals can generate a spike (<1> or <2>) count pulse as shown in the figure below. In this case, an incorrect count operation may occur, or the contents of the count register may be destroyed. So when the count pulse is changed, bit 3 of the count mode register must be set to 1, and the timer must be restarted at the same time.

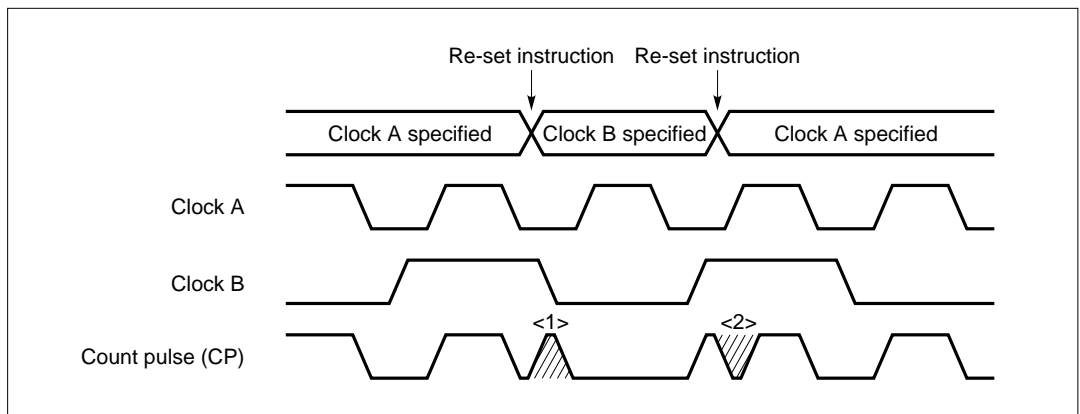

(5) Operation after the modulo register is changed

The contents of the modulo register are changed when an 8-bit data memory manipulation instruction is executed.

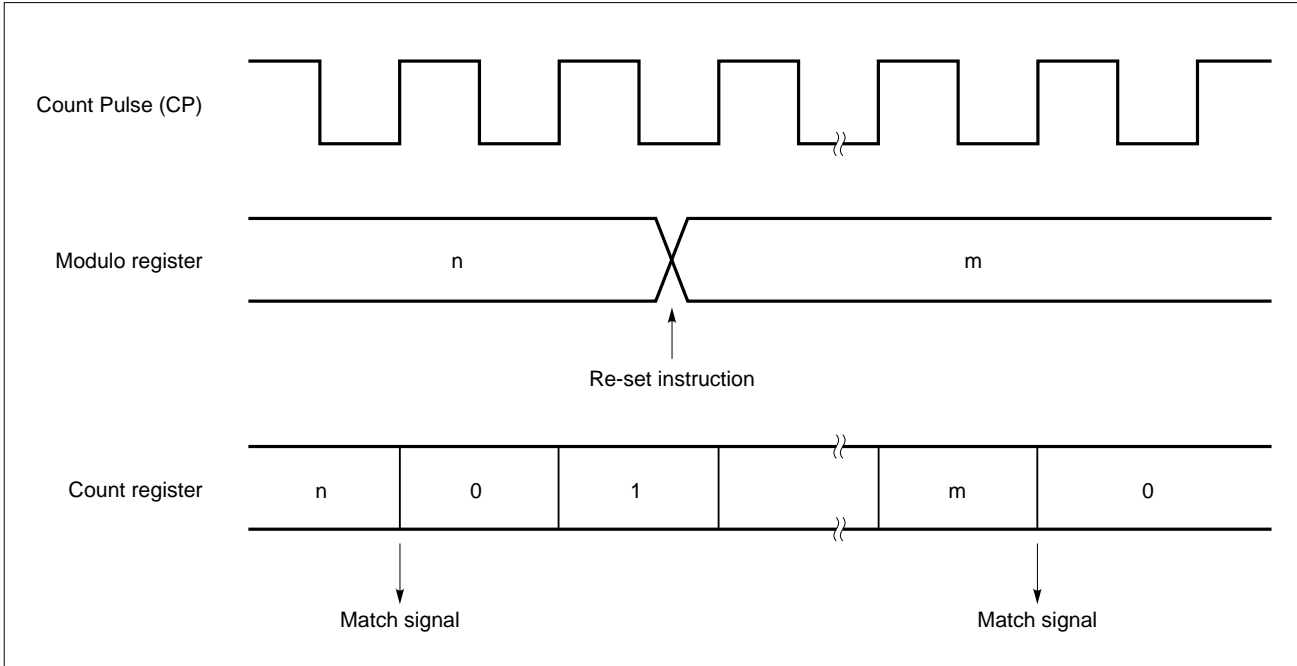

If the new value of the modulo register is less than the value of the count register, the count register continues count operation until it overflows, then it restarts count operation from 0. Accordingly, if the new value (m) of the modulo register is less than the value (n) before it is changed, the timer must be restarted after the contents of the modulo register are changed.

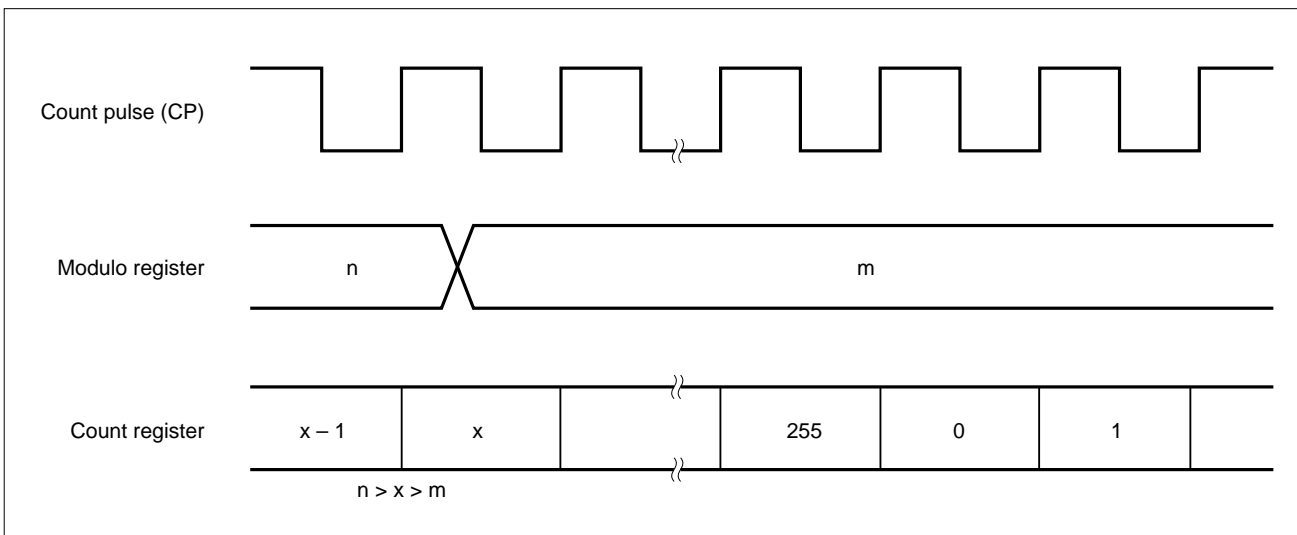

5.5.8 Applications of the Timer/Event Counter

- (1) Timer 0 is used as an interval timer that generates interrupts at intervals of 50 ms.
- The high-order four bits of the mode register are set to 0100B to select maximum set time 62.5 ms.
 - The low-order four bits of the mode register are set to 1100B.
 - The modulo register is set to the following value:
 $50 \text{ ms} / 244 \mu\text{s} = 205 \approx \text{CDH}$

<Sample program>

```

SEL    MB15
MOV    XA,#0CCH
MOV    TMOD0,XA    ; Set the modulo register
MOV    XA,#01001100B
MOV    TM0,XA      ; Set the mode register and start the timer
EI
EI    IET0        ; Enable a timer interrupt

```

Remark In this application, the TI0 pin can be used as an input pin.

- (2) An interrupt is caused when the number of pulses (active high) applied to the TI0 pin reaches 100.
- The high-order four bits of the mode register are set to 0000 to select the rising edge.
 - The low-order four bits of the mode register are set to 1100B.
 - The modulo register is set to $99 = 100 - 1$.

<Sample program>

```

SEL    MB15
MOV    XA,#100-1
MOV    TMOD0,XA    ; Set the modulo register
MOV    XA,#00001100B
MOV    TM0,XA      ; Set the mode register
EI
EI    IET0        ; Enable INTT0

```

5.6 Timer/Pulse Generator

5.6.1 Functions of the Timer/Pulse Generator

The μ PD75518 contains one either timer/pulse generator that can be used as a timer or a pulse generator. It has the following functions:

(1) Functions available when the timer/pulse generator is used in the timer mode

- 8-bit interval timer operation using one of five clock sources (occurrence of IRQTPG)
- Square wave output to the PPO pin

(2) Functions available when the timer/pulse generator is used in the PWM pulse generation mode

- PWM pulse output to the PPO pin with an accuracy of 14 bits (applicable for electronic tuning when used as an D/A converter)
- Generation of interrupts at regular intervals ($2^{15}/f_{\chi} = 5.46$ ms: At 6.0 MHz)(**Note**)

(Note) At 4.19 MHz: $2^{15}/f_{\chi} = 7.81$ ms

If pulse output is unnecessary, the PPO pin can be used as a 1-bit output port.

5.6.2 Timer/Pulse Generator Mode Register (TPGM)

The timer/pulse generator mode register (TPGM) is an 8-bit register that controls operation of the timer/pulse generator. Figure 5-33 shows the format of the register.

TPGM is set using an 8-bit memory manipulation instruction.

Bit 3 enables or disables the transfer (reloading) of the timer/pulse generator modulo register (MODH and MODL) contents to the modulo latch. Bit 3 can be manipulated independently of the other bits.

By setting TPGM1 to 0, timer/pulse generator operation can be stopped to decrease current consumption.

A $\overline{\text{RESET}}$ signal clears all bits to 0.

Figure 5-33. Format of Timer/Pulse Generator Mode Register

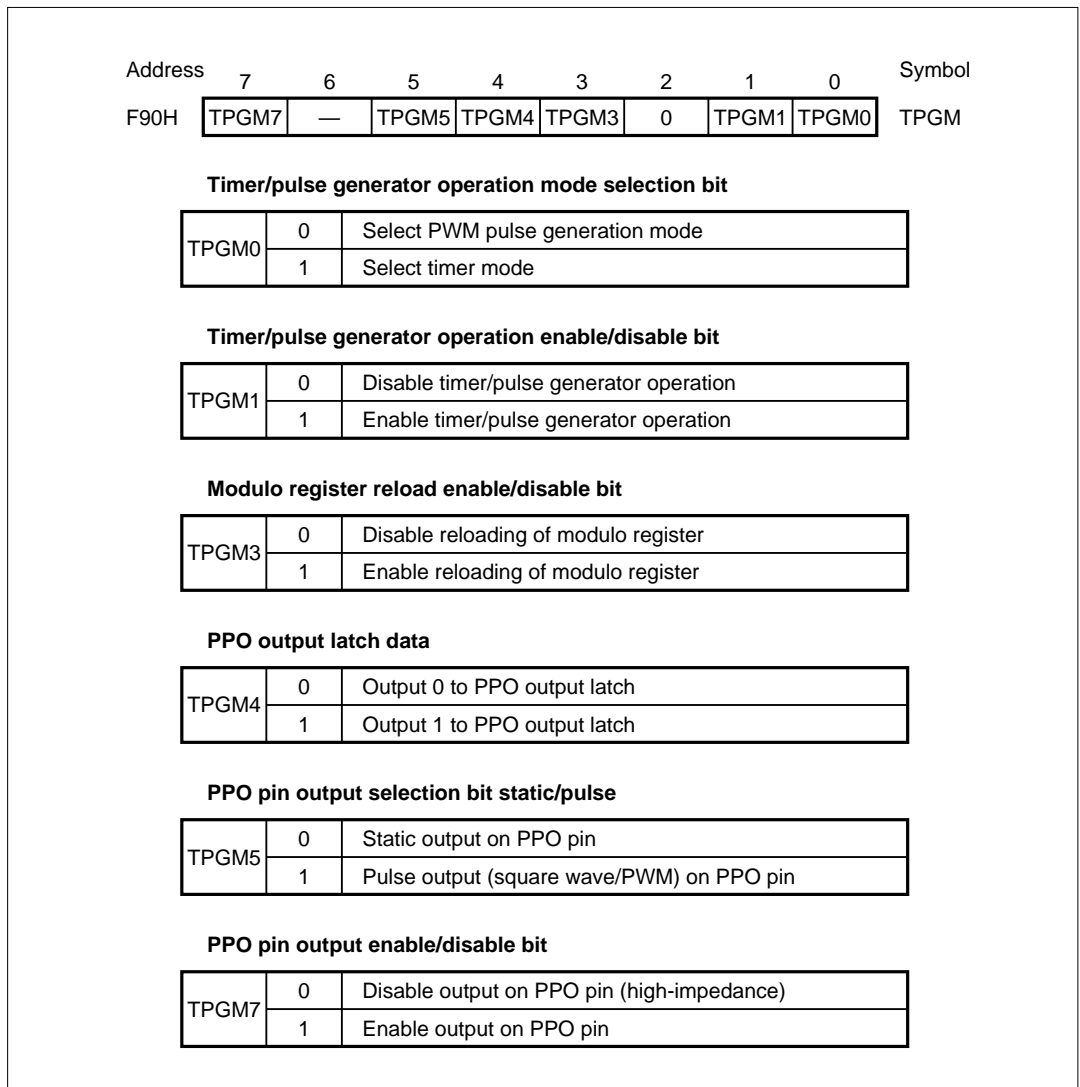

5.6.3 Configuration and Operation of the Timer/Pulse Generator

(1) When the timer/pulse generator is used in the timer mode

Figure 5-34 shows the configuration of the timer/pulse generator when it is used in the timer mode.

The timer mode is selected by setting bit 0 of TPGM to 1. In the timer mode, TPGM3 must be set to 1, allowing the modulo register to be reloaded at any time.

In the timer mode, a prescaler is selected by the modulo register L (MODL), and a frequency or interrupt interval value is set by the modulo register H (MODH). The timer starts when TPGM1 is set to 1. Figure 5-35 shows the operation timing for MODH setting, and Table 5-7 lists frequencies and interrupt intervals that can be set.

The output to the PPO pin can be switched between the square wave output and static output. To output a square wave, set TPGM5 and TPGM7 to 1.

Figure 5-34. Block Diagram of the Timer/Pulse Generator (Timer Mode)

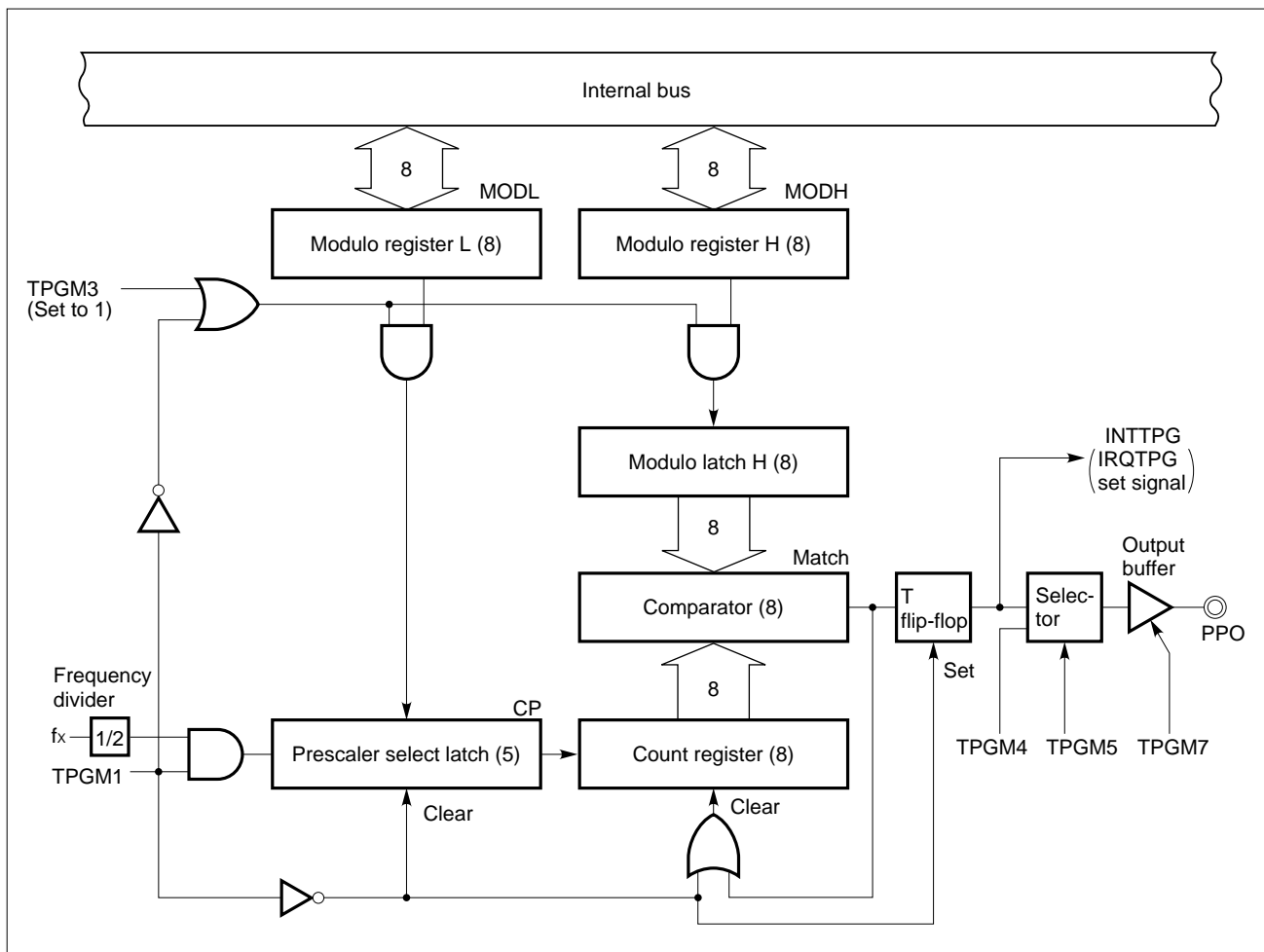

Example 1. Set IRQTPG every 1.95 ms, and output a high on the PPO pin.

```

CLR1   MBE           ; or SEL MB15
MOV    XA,#00100000B
MOV    MODL,XA
MOV    XA,#0FFH
MOV    MODH,XA
MOV    XA,#10011011B
MOV    TPGM,XA       ; Timer start, PPO <- 1
    
```

Caution When the timer operating in the timer operation mode is stopped, IRQTPG may be set because the T flip-flop is set. Therefore, the timer must be stopped with an interrupt being disabled, then IRQTPG must be cleared.

Example 2.

```

DI
CLR1   MBE
MOV    XA,#0
MOV    TPGM,XA
CLR1   IRQTPG
EI
    
```

Figure 5-35. Timer Mode Operation Timing

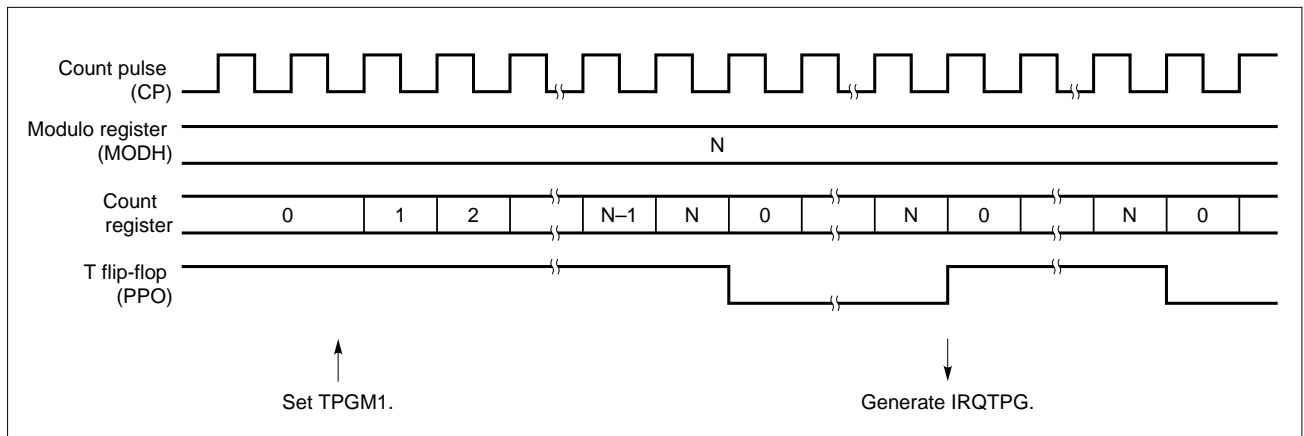

Table 5-7. Modulo Register Settings

(When $f_X = 6.0$ MHz)

MODL bits 2-6					Interrupt generation interval ($f_X = 6.0$ MHz)	Square wave output frequency ($f_X = 6.0$ MHz)
6	5	4	3	2		
0	0	0	0	1	$256(N+1)/f_X = 85.3 \mu\text{s to } 10.9 \text{ ms}$	$f_X/256(N+1) = 91.6 \text{ Hz to } 11.7 \text{ kHz}$
0	0	0	1	0	$128(N+1)/f_X = 42.7 \mu\text{s to } 5.45 \text{ ms}$	$f_X/128(N+1) = 183 \text{ Hz to } 23.4 \text{ kHz}$
0	0	1	0	0	$64(N+1)/f_X = 21.3 \mu\text{s to } 2.73 \text{ ms}$	$f_X/64(N+1) = 366 \text{ Hz to } 46.9 \text{ kHz}$
0	1	0	0	0	$32(N+1)/f_X = 10.7 \mu\text{s to } 1.37 \text{ ms}$	$f_X/32(N+1) = 732 \text{ Hz to } 93.8 \text{ kHz}$
1	0	0	0	0	$16(N+1)/f_X = 5.33 \mu\text{s to } 683 \mu\text{s}$	$f_X/16(N+1) = 1465 \text{ Hz to } 188 \text{ kHz}$

(When $f_X = 4.19$ MHz)

MODL bits 2-6					Interrupt generation interval ($f_X = 6.0$ MHz)	Square wave output frequency ($f_X = 6.0$ MHz)
6	5	4	3	2		
0	0	0	0	1	$256(N+1)/f_X = 122 \mu\text{s to } 15.6 \text{ ms}$	$f_X/256(N+1) = 64 \text{ Hz to } 8 \text{ kHz}$
0	0	0	1	0	$128(N+1)/f_X = 61.0 \mu\text{s to } 7.81 \text{ ms}$	$f_X/128(N+1) = 128 \text{ Hz to } 16 \text{ kHz}$
0	0	1	0	0	$64(N+1)/f_X = 30.5 \mu\text{s to } 3.91 \text{ ms}$	$f_X/64(N+1) = 256 \text{ Hz to } 32 \text{ kHz}$
0	1	0	0	0	$32(N+1)/f_X = 15.3 \mu\text{s to } 1.95 \text{ ms}$	$f_X/32(N+1) = 512 \text{ Hz to } 65 \text{ kHz}$
1	0	0	0	0	$16(N+1)/f_X = 7.63 \mu\text{s to } 977 \mu\text{s}$	$f_X/16(N+1) = 1024 \text{ Hz to } 131 \text{ kHz}$

-
- Cautions 1. A value other than the above cannot be set in MODL. Bits 0, 1, and 7 must be set to 0.**
- 2. N is the value set in MODH. 0 must not be set for N. Be sure to set a value from 1 to 255 for N.**
-

(2) When the timer/pulse generator is used in the PWM pulse generation mode

Figure 5-36 shows the configuration of the timer/pulse generator when it is used in the PWM pulse generation mode.

The PWM pulse generation mode is selected by setting TPGM0 to 0. TPGM5 and TPGM7 are set to 1 to enable pulse output. In the PWM mode, the PWM pulse signal can be output on the PPO pin, and IRQTPG can be set at intervals of a fixed time period ($2^{15}/f_X = 5.46$ ms: At 6.0 MHz)(**Note**).

PWM pulses output by the μ PD75518 are active-low and have a precision of 14 bits. This pulse signal is applicable for electronic tuning and control of a DC motor when it is converted to analog voltage through integration using an external low-pass filter. (See **Figure 5-37**.)

The PWM pulse signal is generated by combining the basic period determined by $2^{10}/f_X$ and the secondary period by $2^{15}/f_X$ so that the time constant of the external low-pass filter can be decreased.

Table 5-8 lists the basic and secondary periods by oscillator frequency.

(Note) At 4.19 MHz: $2^{15}/f_X = 7.81$ ms

Table 5-8. Basic and Secondary Periods

	$f_X = 6.0$ MHz	$f_X = 4.19$ MHz
Basic period ($2^{10}/f_X$)	171 μ s	244 μ s
Secondary period ($2^{15}/f_X$)	5.46 ms	7.81 ms

The low-level width of a PWM pulse depends on the 14-bit modulo latch value. The upper 8 bits of the modulo latch are transferred from the 8 bits of MODH, and the lower 6 bits of the latch are transferred from the upper 6 bits of MODL.

When the PWM pulse signal is converted to analog form in the configuration as shown in Figure 5-37, the voltage level of the analog output is obtained as follows:

$$V_{AN} = V_{ref} \times \text{Value of modulo latch} / 2^{14}$$

Vref: Reference voltage of external switching circuitry

To prevent an incorrect PWM pulse from being output by unstable modulo latch data being rewritten, in the μ PD75518, correct data can be written into MODH and MODL beforehand with 8-bit manipulation instructions, then the written 14-bit data can be transferred to the modulo latch at one time. This transfer is referred to as reloading, and it is controlled by TPGM3. If TPGM3 is 0, reloading is disabled, and if it is 1, reloading is enabled. Follow the procedure below to rewrite the modulo latch contents:

- <1> Clear TPGM3 to disable reloading.
- <2> Change the MODH and MODL contents.
- <3> Set TPGM3 to 1 to enable reloading.

-
- Cautions**
1. If the modulo register H (MODH) is set to 0, the PWM pulse generator can not function normally. So be sure to set MODH to a value from 1 to 255.
 2. If the lower 2 bits of the modulo register L (MODL) is read, the read result is unpredictable.
 3. If the modulo latch is changed in a shorter period than the PWM pulse basic period $2^{10}/f_{\chi}$ (171 μ s: At 6.0 MHz)(Note), PWM pulses do not change.
-

(Note) At 4.19 MHz: $2^{10}/f_{\chi} = 244 \mu$ s

Example Decrease analog output voltage to the lowest level, then increase it to the highest level.

```

CLR1  MBE
MOV   XA,#01H
MOV   MODH,XA      ; MODH <- 01
MOV   MODL,XA      ; MODL <- 01
MOV   XA,#10101010B
MOV   TPGM,XA      ; Enable PWM pulse output
:
:
CLR1  TPGM.3       ; Disable reloading
MOV   XA,#0FFH
MOV   MODH,XA
MOV   MODL,XA
SET1  TPGM.3       ; Enable reloading

```

Figure 5-36. Block Diagram of the Timer/Pulse Generator (PWM Pulse Generation Mode)

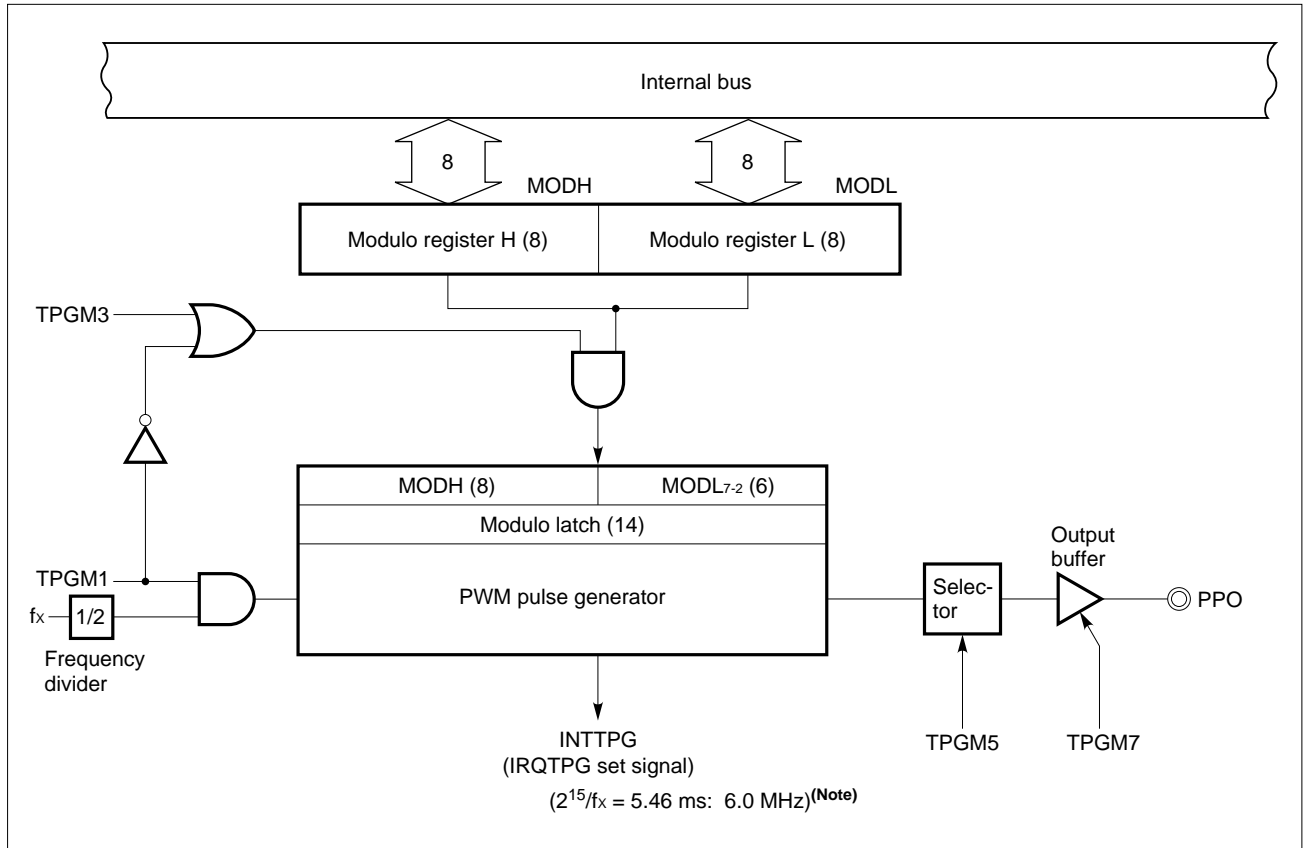

(Note) At 4.19 MHz: $2^{15}/f_x = 7.81$ ms

Figure 5-37. Sample Configuration of D/A Conversion Using μ PD75518

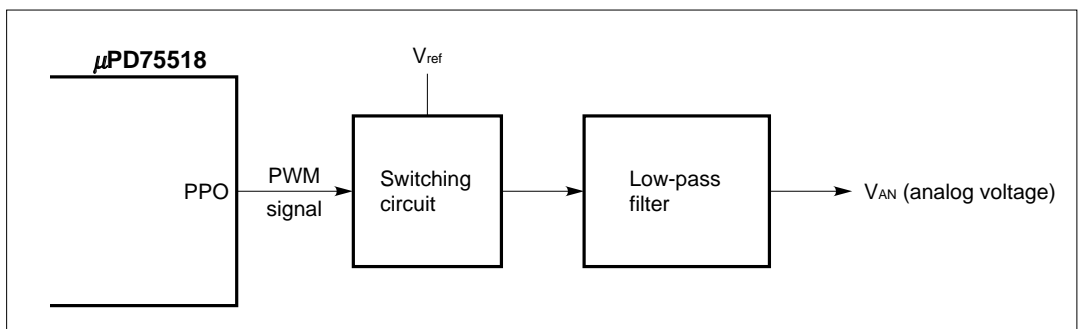

(3) Static output to the PPO pin

When pulse output is unnecessary, the PPO pin can be used as normal static output. In this case, the output data is set in TPGM4 with TPGM5 set to 0 and TPGM7 to 1.

5.6.4 Application of the Timer/Pulse Generator

(1) The timer/pulse generator is used as an interval timer which generates interrupts at 1-ms intervals when $f_X = 4.194304$ MHz.

From Table 5-7, an equation for setting the timer to 1 ms is selected. Since N is an integer from 1 to 255, there is some difference between the set time and an actual time. To obtain high resolution (that is, to suppress the difference as little as possible), the value of N must be as large as possible.

$$T = 32(N + 1)/f_X \text{ (modulo register L (MODL) = 20H)}$$

Since $T = 1$ ms, the value N to be set in modulo register H (MODH) is

$$N = f_X/32 \times T - 1 = 4.194304 \times 10^6/32 \times 1 \times 10^{-3} - 1 = 130.072$$

Therefore, N is set to 130. When $N = 130$, the actual time is obtained as follows:

$$T = 32(N + 1)/f_X = 32(130 + 1)/4.194304 \times 10^6 = 0.999 \text{ (ms)}$$

The error is 0.05%.

<Sample program>

```

CLR1   MBE
MOV    XA,#20H      ; Select resolution
MOV    MODL,XA
MOV    XA,#82H      ; Determine set value
MOV    MODH,XA
MOV    XA,#10011011B
MOV    TPGM,XA     ; Start timer
EI                      ; Enable interrupt
EI    IETPG        ; Enable timer interrupt

```

(2) The timer/pulse generator is used for electronic tuning by converting the PWM pulse signal output on the PPO pin to analog voltage form.

Figure 5-38 shows a sample circuit which applies to a voltage synthesizer TV tuner.

Figure 5-38. Sample Circuit Applicable to TV Tuners *

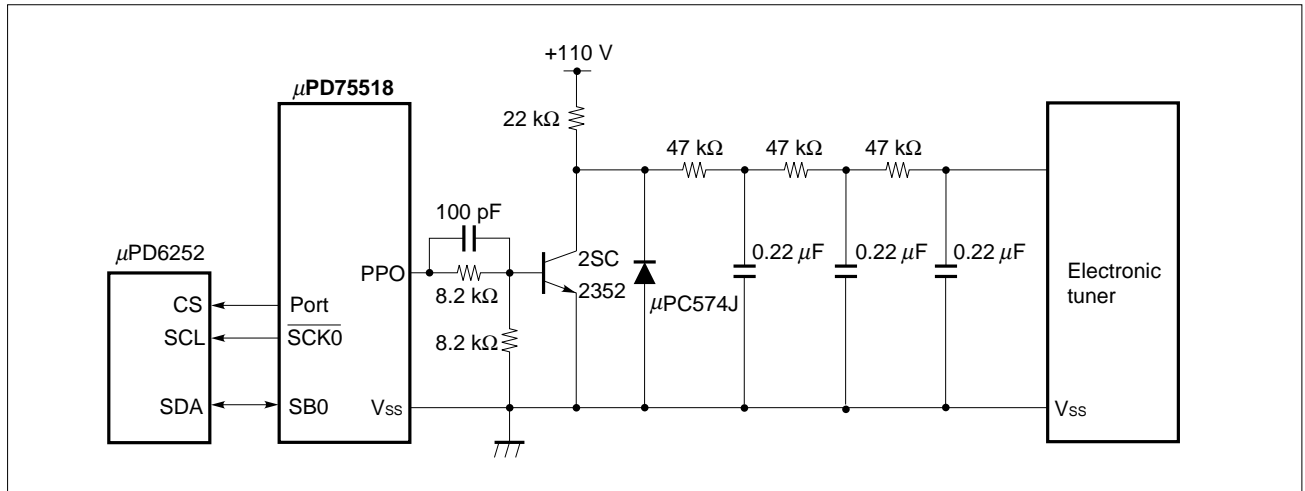

Even in the above simple circuit configuration, high performance, including a ripple voltage of 2 mVp-p and a response rate of 100 ms, can be obtained.

If f_x is 4.19 MHz, the ripple voltage components include a 4.096-kHz component caused by the basic period and a 128-Hz component caused by the secondary period. (The 128-Hz component is very small, and the frequency 256 Hz can be regarded as the lowest ripple component frequency.)

As shown in Figure 5-38, the pulse signal output on the PPO is inverted by an external transistor. The period of a low output on the PPO corresponds to the value written in the timer/pulse generator modulo register.

The tuning voltage is preset with the AFC and horizontal synchronizing signals. The resultant tuning data is written to the non-volatile memory μ PD6252.

(3) Musical notes are output on the PPO pin. (A square wave is output on the PPO pin at a given frequency.)

The frequency of clock oscillation is set to 4.19 MHz.

Although various frequencies from 64 Hz to 131 kHz are possible by setting the timer/pulse generator modulo register, the resolution is restricted. (See **Table 5-7.**) This means that generated notes have errors. See Table 5-9. According to the table, to generate a one-octave higher tone the MODL value is doubled.

As shown in Table 5-7, to increase the resolution (for fine tuning), the value N must be as large as possible. In Table 5-9, a large value is set in MODL to obtain a large value for N.

<Sample program> Tone la: Output 440 Hz.

```

CLR1   MBE
MOV    XA,#10H      ; Select output frequency
MOV    MODL,XA
MOV    XA,#94H      ; 440Hz
MOV    MODH,XA
MOV    XA,#10101011B
MOV    TPGM,XA     ; Start note output
    
```

Table 5-9. Generation of Notes Using the Timer/Pulse Generator

Temperament		Modulo register setting		Output from PPO	
Note	Frequency [Hz]	MODL	MODH	Frequency [Hz]	Error [Hz]
La A	440	00010000B	94H	439.8	-0.2 (-0.045%)
A#	446.16	00010000B	8CH	464.8	-1.36 (-0.29%)
Ti B	493.88	00010000B	84H	492.8	-1.08 (-0.22%)
Do C ₅	523.248	00100000B	F9H	524.29	1.04 (0.20%)
C#	554.368	00100000B	EBH	555.39	1.02 (0.18%)
Re D	587.328	00100000B	DEH	587.77	0.442 (0.075%)
D#	662.256	00100000B	D2H	621.2	-1.06 (-0.17%)
Mi E	659.248	00100000B	C6H	658.7	-0.548 (-0.083%)
Fa F	698.464	00100000B	BBH	697.2	-1.264 (-0.12%)
F#	739.984	00100000B	B0H	740.5	0.516 (0.070%)
So G	783.984	00100000B	A6H	784.9	0.916 (0.117%)
G#	830.608	00100000B	9DH	829.7	-0.908 (-0.11%)

(4) A square wave output on the PPO pin is used as a baud rate generator for the serial interface.

The PPO is connected to $\overline{SCK0}$ as shown below.

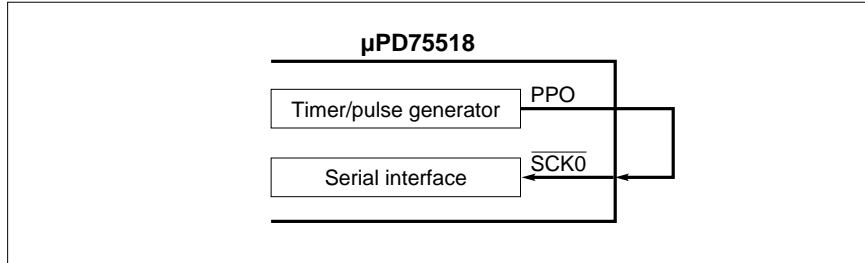

*

The timer/pulse generator uses the main system clock whose frequency (f_X) is divided by two as count pulse. *

To obtain a baud rate of 9600, use a system clock whose frequency (f_X) is 4.9142 MHz.

- The mode register (TPGM) is set to 10111011B (square wave output mode).
- The modulo register is set as listed below. Modulo register L (MODL) is set to 08H.

Baud rate	Modulo register H (MODH)
9600	03H
4800	07H
2400	0FH
1200	1FH
600	3FH
300	7FH
150	FFH

Caution In this application, a main system clock whose frequency is 4.9152 MHz is used. When selecting CPU clock Φ for the μ PD75518, set the PCC to 0010B (1 machine cycle = 1.63 μ s at 614 kHz) or 0000B (1 machine cycle = 13 μ s at 76.7 kHz). If the PCC is set to 0011B, one machine cycle falls short of 0.95 μ s, the minimum value in the specifications. *

<Sample program> Data is output at 9600 baud starting with LSB.

```
CLR1  MBE
MOV   XA,#08H      ; Select output frequency band
MOV   MODL,XA
MOV   XA,#03H      ; 9600 baud
MOV   MODH,XA
MOV   XA,#10111011B
MOV   TPGM,XA      ; Start timer, high output on PPO
MOV   XA,#1FH      ; LSB, PPO ->  $\overline{\text{SCK0}}$ , SO0 -> H
MOV   SIOM,XA      ; Transfer start
MOV   XA,DATA      ; Transfer data set
MOV   SIO0,XA
```

5.7 Serial Interface (Channel 0)

The μ PD75518 has two channels of serial interface: Channel 0 and channel 1. Table 5-10 lists the differences between channel 0 and channel 1.

Table 5-10. Differences between Channel 0 and Channel 1

Serial transfer mode, function		Channel 0	Channel 1
3-wire serial I/O	Clock selection	$f_X/2^4$, $f_X/2^3$, TOUT flip-flop, external clock	$f_X/2^4$, $f_X/2^3$, external clock
	Transfer method	Start bit switchable: MSB/LSB	Start bit: MSB
	Transfer end flag	Serial transfer end interrupt request flag (IRQCSI0)	Serial transfer end flag (EOT)
2-wire serial I/O		Available	Not available
Serial bus interface			

5.7.1 Serial Interface (Channel 0) Functions

The serial interface (channel 0) of the μ PD75518 has four modes.

The functions of the four modes are outlined below.

(1) Operation halt mode

This mode is used when serial transfer is not performed. This mode reduces power consumption.

(2) Three-wire serial I/O mode

In this mode, 8-bit data is transferred through three lines: Serial clock ($\overline{SCK0}$), serial output (SO0), and serial input (SI0).

The three-wire serial I/O mode allows full-duplex transmission, so data transfer can be performed at higher speed.

The user can choose 8-bit data transfer starting with the MSB or LSB, so devices starting with either the MSB or LSB can be connected.

The three-wire serial I/O mode enables connections to be made with the 75X series, 78K series, and many other types of peripheral I/O devices.

(3) Two-wire serial I/O mode

In this mode, 8-bit data is transferred through two lines: Serial clock ($\overline{SCK0}$) and serial data bus (SB0 or SB1). By controlling output levels on the two lines by software, communication with multiple devices is enabled.

The output levels of $\overline{SCK0}$ and SB0 (or SB1) can be controlled by software, so the user can match an arbitrary transfer format. This means that a line that has been required for handshaking to connect multiple lines can be eliminated for more efficient input/output port utilization.

(4) Serial bus interface (SBI) mode

In this mode, communication with multiple devices can be performed using two lines: Serial clock ($\overline{SCK0}$) and serial data bus (SB0 or SB1).

This mode conforms to the NEC serial bus format.

In this mode, the transmitter can output, on the serial data bus, an address for selecting a device subject to serial communication, commands directed to the remote device, and data. The receiver can identify an address, commands, and data from received data by hardware.

This function enables more efficient input/output port utilization as in the case of the two-wire serial I/O mode. In addition, this function can simplify the serial interface control portion of an application program.

Figure 5-39. Example of the SBI System Configuration

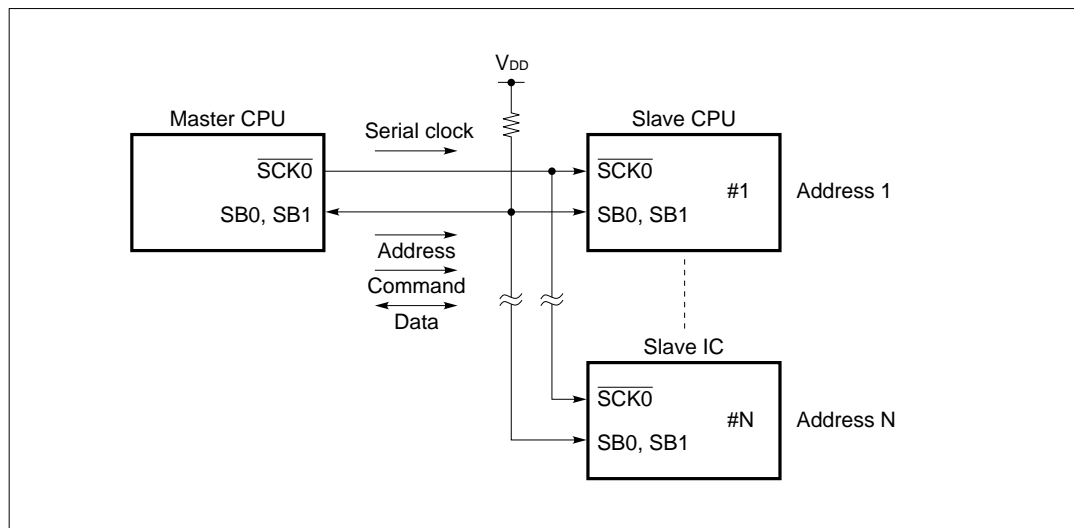

5.7.2 Configuration of Serial Interface (Channel 0)

Figure 5-40 shows the block diagram of the serial interface (channel 0).

Figure 5-40. Block Diagram of the Serial Interface (Channel 0)

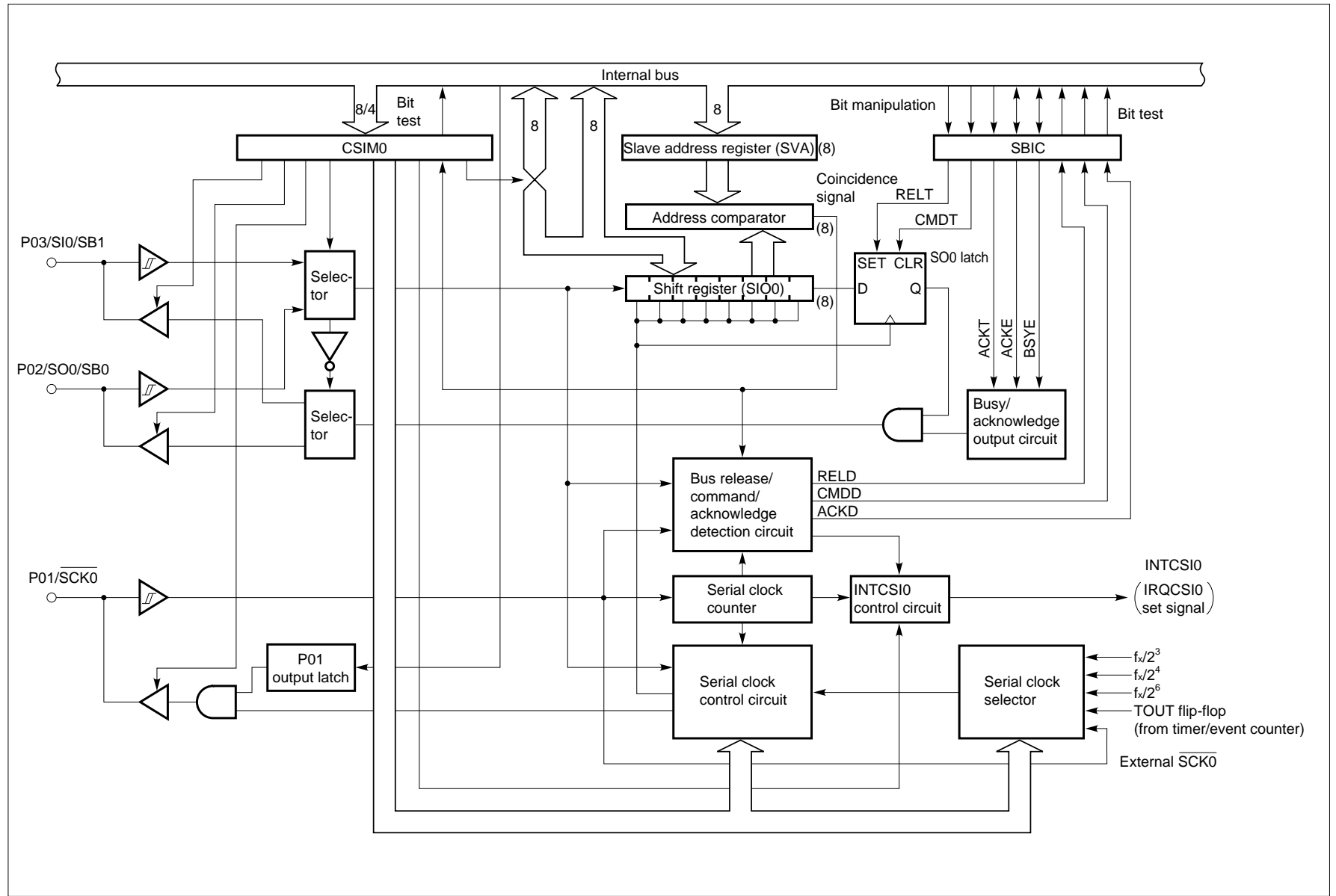

(1) Serial operation mode register 0 (CSIM0)

CSIM0 is an 8-bit register which specifies a serial interface operation mode, serial clock, wake-up function, and so forth. (See (1) in **Section 5.7.3** for details.)

(2) Serial bus interface control register (SBIC)

SBIC is an 8-bit register consisting of bits for controlling the serial bus and flags for indicating the states of input data from the serial bus. SBIC is used mainly in the SBI mode. (See (2) in **Section 5.7.3** for details.)

(3) Shift register 0 (SIO0)

SIO0 is an 8-bit register which converts 8-bit serial data to parallel data, and 8-bit parallel data to serial data. SIO0 performs transfer (shift) in phase with the serial clock. Transfers operations are controlled by writing data to SIO0. (See (3) in **Section 5.7.3** for details.)

(4) SO0 latch

SO0 is a latch to hold the levels of pins SO0 and SB0, or SI0 and SB1, which can be controlled directly by software. In the SBI mode, SO0 is set when the eighth clock of $\overline{\text{SCK0}}$ has been output. (See (2) in **Section 5.7.3** for details.)

(5) Serial clock selector

The serial clock selector selects the serial clock to be used.

(6) Serial clock counter

The serial clock counter counts the serial clock to be output or input during transfer, and checks whether 8-bit data has been transferred.

(7) Slave address register (SVA) and address comparator**• In the SBI mode**

SVA is used when the $\mu\text{PD75518}$ is used as a slave device. A slave sets the number assigned to it (slave address) in SVA. The master outputs a slave address to select a particular slave.

Two data values (a slave address output from the master and the value of SVA) are compared with each other by the address comparator. If a match is found, the slave is selected.

• In the two-wire serial I/O mode or SBI mode

SVA detects an error when data is transferred with the $\mu\text{PD75518}$ operating as the master or a slave. (See (4) in **Section 5.7.3** for details.)

(8) INTCSI0 control circuit

The IRQCSI0 control circuit controls interrupt request processing. The circuit issues an interrupt request (INTCSI0), and set an interrupt request flag (IRQCSI0) in the following cases. (See **Figure 6-1**.)

- **In the three-wire or two-wire serial I/O mode**

An interrupt request is issued whenever eight serial clocks are counted.

- **In the SBI mode**

When WUP7(**Note**) = 0, an interrupt request is issued whenever eight serial clocks are counted. When WUP = 1, an interrupt request is issued when values of SVA and SIO0 match after an address is received.

(Note) WUP: Wake-up function specification bit (bit 5 of CSIM0)

(9) Serial clock control circuit

The serial clock control circuit controls the serial clock to be supplied to the shift register, or controls the clock to be output to the $\overline{\text{SCK0}}$ pin when the internal system clock is used.

(10) Busy/acknowledge output circuit and bus release/command/acknowledge detection circuit

The busy/acknowledge output circuit and bus release/command/acknowledge detection circuit output and detect control signals generated in the SBI mode.

These circuits do not operate in the three-wire or two-wire serial I/O mode.

(11) P01 output latch

The P01 output latch generates serial clock by software after the eighth serial clock has been output.

When the RESET signal is entered, this latch is set to 1.

To select the internal system clock as the serial clock, set the P01 output latch to 1.

5.7.3 Register Functions

(1) Serial operation mode register 0 (CSIM0)

Figure 5-41 shows the format of serial operation mode register 0 (CSIM0).

CSIM0 is an 8-bit register which specifies a serial interface (channel 0) operation mode, serial clock, wake-up function, and so forth.

CSIM0 is manipulated using an 8-bit memory manipulation instruction. The higher three bits can be manipulated bit by bit. Each bit can be manipulated using its name.

Each bit may or may not allow read and/or write operation (see **Figure 5-41**). Bit 6 allows bit test operation only; any data written to this bit is invalid.

When the $\overline{\text{RESET}}$ signal is input, this register is set to 00H.

Figure 5-41. Format of Serial Operation Mode Register 0 (CSIM0) (1/3)

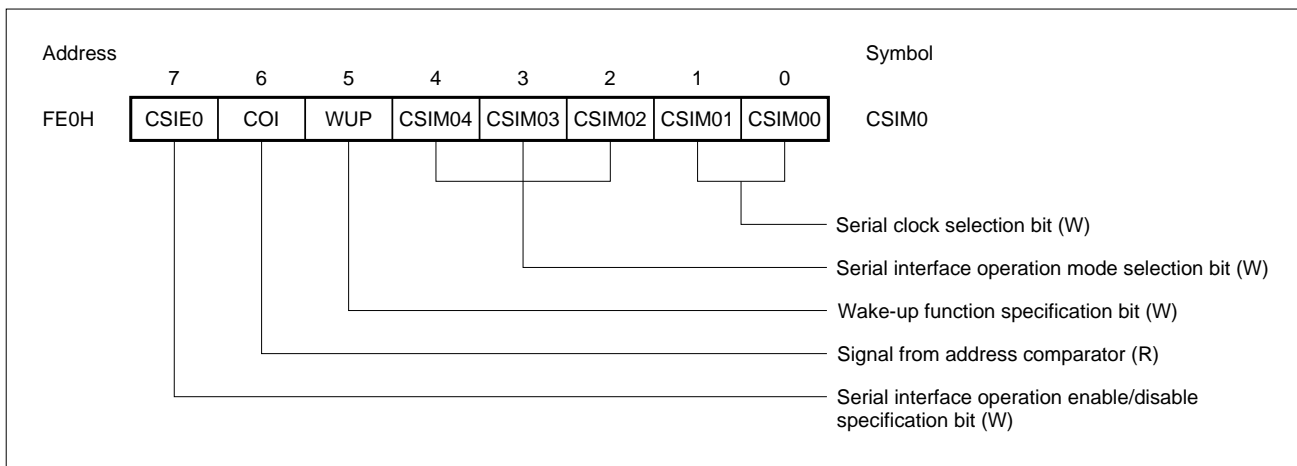

Remark (R) : Read only
(W) : Write only

Figure 5-41. Format of Serial Operation Mode Register 0 (CSIM0) (2/3)

Serial clock selection bit (W)

CSIM01	CSIM00	Serial clock			$\overline{\text{SCK0}}$ pin mode
		3-wire serial I/O mode	SBI mode	2-wire serial I/O mode	
0	0	Input clock externally applied to $\overline{\text{SCK0}}$ pin			Input
0	1	Timer/event counter output (T0)			Output
1	0	$f_X/2^4$ (262 kHz or 375 kHz)(Note)	$f_X/2^6$ (65.5 kHz or 93.8 kHz)(Note)		
1	1	$f_X/2^3$ (524 kHz or 750 kHz)(Note)			

(Note) The values in parentheses are for $f_X = 4.19$ MHz or 6.0 MHz.

Serial interface operation mode selection bit (W)

CSIM04	CSIM03	CSIM02	Operation mode	Bit order of shift register	SO0 pin function	SI0 pin function
x	0	0	3-wire serial I/O mode	$\text{SIO0}_{7-0} \leftarrow \text{XA}$ (Transfer start with MSB)	SO0/P02 (CMOS output)	SI0/P03 (Input)
		1		$\text{SIO0}_{0-7} \leftarrow \text{XA}$ (Transfer starting with LSB)		
0	1	0	SBI mode	$\text{SIO0}_{7-0} \leftarrow \text{XA}$ (Transfer starting with MSB)	SB0/P02 (N-ch open-drain I/O)	P03 input
1		P02 input			SB1/P03 (N-ch open-drain I/O)	
0	1	1	2-wire serial I/O mode	$\text{SIO0}_{7-0} \leftarrow \text{XA}$ (Transfer starting with MSB)	SB0/P02 (N-ch open-drain I/O)	P03 input
1					P02 input	SB1/P03 (N-ch open-drain I/O)

Remark x: Don't care

Figure 5-41. Format of Serial Operation Mode Register 0 (CSIM0) (3/3)

Wake-up function specification bit (W)

WUP	0	Sets IRQCSI0 each time serial transfer is completed in each mode.
	1	Used in the SBI mode only to set IRQCSI0 only when an address received after bus release matches the data in the slave address register (wake-up state). SB0 or SB1 goes to high-impedance state.

Caution When WUP = 1 is set during $\overline{\text{BUSY}}$ signal output, $\overline{\text{BUSY}}$ is not released. In the SBI mode, the $\overline{\text{BUSY}}$ signal is output until the next falling edge of the serial clock (SCK0) appears after release of $\overline{\text{BUSY}}$ is directed. Before setting WUP = 1, be sure to confirm that pin SB0 (or SB1) is high after releasing $\overline{\text{BUSY}}$.

Signal from address comparator (R)

COI(Note)	Condition for being cleared (COI = 0)	Condition for being set (COI = 1)
	When the data in the slave address register (SVA) does not match the data in the shift register	When the data in the slave address register (SVA) matches the data in the shift register

(Note) COI can be read only before serial transfer is started or after serial transfer is completed. An undefined value may result during transfer. COI data written by an 8-bit manipulation instruction is ignored.

Serial interface operation enable/disable specification bit (W)

		Shift register operation	Serial clock counter	IRQCSI0 flag	SO0/SB0 and SI0/SB1 pins
CSIE0	0	Shift operation disabled	Cleared	Held	Used only for port 0
	1	Shift operation enabled	Count operation	Can be set.	Used in each mode as well as for port 0

Remarks 1. Each mode can be selected using CSIE0, CSIM03, and CSIM02.

CSIE0	CSIM03	CSIM02	Operation mode
0	x	x	Operation halt mode
1	0	x	Three-wire serial I/O mode
1	1	0	SBI mode
1	1	1	Two-wire serial I/O mode

2. x: Don't care

Remarks 3. The P01/SCK0 pin assumes any of the following states according to the state of CSIE0, CSIM01, and CSIM00:

CSIE0	CSIM01	CSIM00	P01/SCK0 pin state
0	0	0	Input port
0	0	1	High level output
0	1	0	
0	1	1	
1	0	0	High impedance
1	0	1	Serial clock output (High level output)
1	1	0	
1	1	1	

4. When clearing CSIE0 during serial transfer, use the following procedure:
- <1> Disable interrupts by clearing the interrupt enable flag (IECSI0).
 - <2> Clear CSIE0.
 - <3> Clear the interrupt request flag (IRQCSI0).

Example 1. $f_X/2^4$ is selected as the serial clock, serial interrupt IRQCSI0, is generated each time serial transfer is completed, and serial transfer is performed in the SBI mode with the SB0 pin used as the serial data bus.

```
SEL    MB15          ; or CLR1 MBE
MOV    XA,#10001010B
MOV    CSIM0,XA      ; CSIM0 <- 10001010B
```

Example 2. Serial transfer dependent on the contents of CSIM0 is enabled.

```
SEL    MB15          ; or CLR1 MBE
SET1   CSIE0
```

(2) Serial bus interface control register (SBIC)

Figure 5-42 shows the format of the serial bus interface control register (SBIC).

SBIC is an 8-bit register consisting of bits for controlling the serial bus and flags for indicating the states of input data from the serial bus. SBIC is used mainly in the SBI mode.

SBIC is manipulated using a bit manipulation instruction. SBIC cannot be manipulated using a 4-bit or 8-bit memory manipulation instruction.

Each bit may or may not allow read and/or write operation (**Figure 5-42**).

When the RESET signal is input, this register is set to 00H.

Caution **Only the following bits can be used in the three-wire and two-wire serial I/O modes:**

- Bus release trigger bit (RELT): Sets the SO0 latch.
- Command trigger bit (CMDT): Clears the SO0 latch.

Figure 5-42. Format of Serial Bus Interface Control Register (SBIC) (1/3)

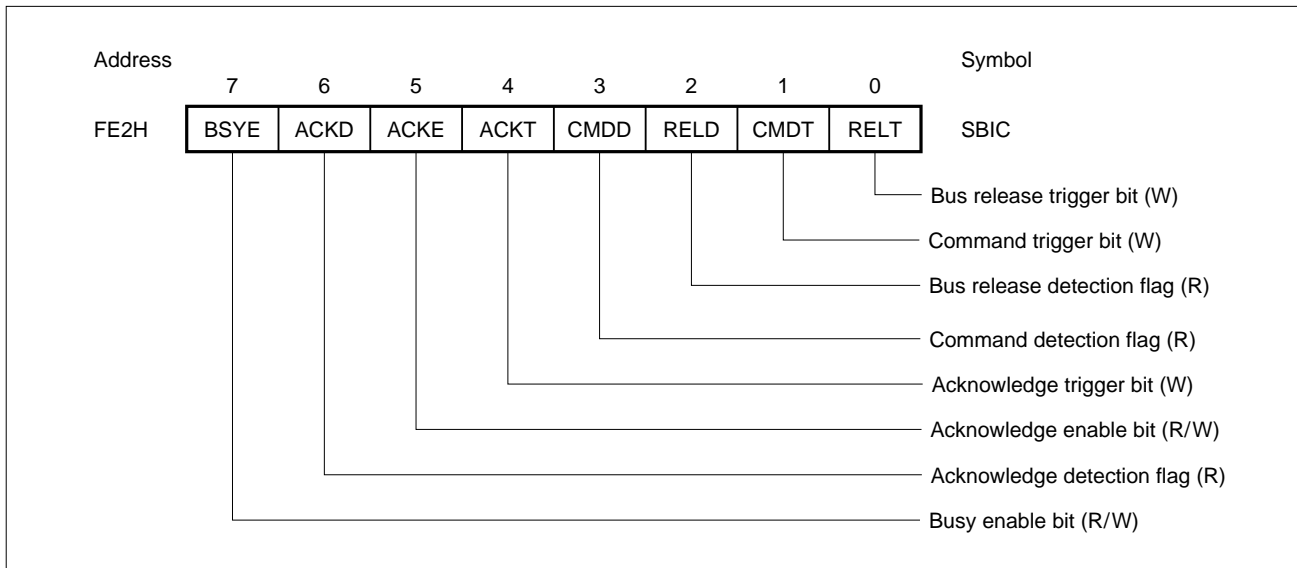

Remark (R) : Read only
 (W) : Write only
 (R/W): Read/write

Figure 5-42. Format of Serial Bus Interface Control Register (SBIC)(2/3)

Bus release trigger bit (W)

REL T	Control bit for bus release signal (REL) trigger output. By setting REL T = 1, the SO0 latch is set to 1. Then the REL T bit is automatically cleared to 0.
-------	---

Caution **Never clear SB0 (or SB1) during serial transfer. Be sure to clear SB0 (or SB1) before or after serial transfer.**

Command trigger bit (W)

C M D T	Control bit for command signal (CMD) trigger output. By setting C M D T = 1, the SO0 latch is cleared. Then the C M D T bit is automatically cleared.
---------	---

Caution **Never clear SB0 (or SB1) during serial transfer. Be sure to clear SB0 (or SB1) before or after serial transfer.**

Bus release detection flag (R)

R E L D	Condition for being cleared (R E L D = 0)	Condition for being set (R E L D = 1)
	<ul style="list-style-type: none"> <1> The transfer start instruction is executed. <2> The $\overline{\text{RESET}}$ signal is entered. <3> CSIE0 = 0 (Figure 5-41) <4> SVA does not match SIO0 when an address is received. 	The bus release signal (REL) is detected.

Command detection flag (R)

C M D D	Condition for being cleared (C M D D = 0)	Condition for being set (C M D D = 1)
	<ul style="list-style-type: none"> <1> The transfer start instruction is executed. <2> The bus release signal (REL) <3> The $\overline{\text{RESET}}$ signal is entered. <4> CSIE0 = 0 (Figure 5-41) 	The command signal (CMD) is detected.

Figure 5-42. Format of Serial Bus Interface Control Register (SBIC) (3/3)

Acknowledge trigger bit (W)

ACKT	When set after transfer, \overline{ACK} is output in phase with the next $\overline{SCK0}$. After \overline{ACK} signal output, this bit is automatically cleared to 0.
------	--

- Cautions**
1. Never set ACKT before or during serial transfer.
 2. ACKT cannot be cleared by software.
 3. Before setting ACKT, set ACKE = 0.

Acknowledge enable bit (R/W)

ACKE	0	Disables automatic output of the acknowledge signal (\overline{ACK}). (Output by ACKT is possible.)	
	1	When set before transfer	\overline{ACK} is output in phase with the 9th clock of $\overline{SCK0}$.
		When set after transfer	\overline{ACK} is output in phase with $\overline{SCK0}$ immediately following the set instruction execution.

Acknowledge detection flag (R)

ACKD	Condition for being cleared (ACKD = 0)		Condition for being set (ACKD = 1)
		<1> The transfer operation is started. <2> The RESET signal is entered.	The acknowledge signal (\overline{ACK}) is detected (in phase with the rising edge of $\overline{SCK0}$).

Busy enable bit (R/W)

BSYE	0	<1> The busy signal is automatically disabled. <2> Busy signal output is stopped in phase with the falling edge of $\overline{SCK0}$ immediately after clear instruction execution.
	1	The busy signal is output after the acknowledge signal in phase with the falling edge of $\overline{SCK0}$.

Example 1. A command signal is output.

```

SEL      MB15  ; or CLR1 MBE
SET1     CMDT
    
```

Example 2. RELD and CMDD are tested to identify the types of received data and the types of processing accordingly. By setting WUP = 1, this interrupt routine is processed only when an address match is found.

```

SEL      MB15  ; or CLR1 MBE
SKF      RELD  ; RELD test
BR       !ADRS
SKT      CMDD  ; CMDD test
BR       !DATA

CMD      :      .....  ; Command analysis
DATA     :      .....  ; Data processing
ADRS     :      .....  ; Address decode
    
```

(3) Shift register 0 (SIO0)

Figure 5-43 shows the configuration of peripheral hardware of shift register 0. SIO0 is an 8-bit register which performs parallel-serial conversion and serial transfer (shift) operation in phase with the serial clock.

Serial transfer is started by writing data to SIO0.

In transmission, data written to SIO0 is output on the serial output (SO0) or serial data bus (SB0 or SB1). In receive operation, data is read from the serial input (SI0) or SB0 or SB1 into SIO0.

Data can be read from or written to SIO0 by using an 8-bit manipulation instruction.

When the $\overline{\text{RESET}}$ signal is entered during operation, the value of SIO0 is undefined. When the RESET signal is entered in the standby mode, the value of SIO0 is preserved.

Shift operation is stopped after 8-bit send or receive operation is completed.

Figure 5-43. Peripheral Hardware of Shift Register 0

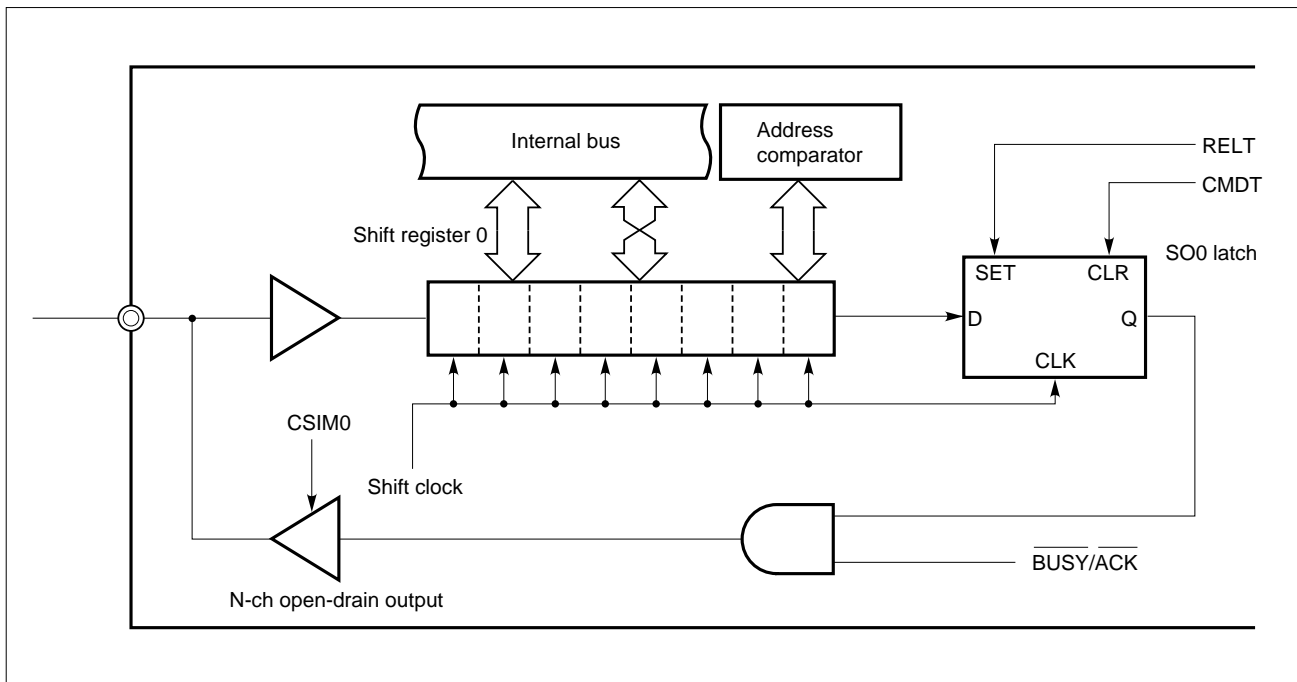

The timing for reading SIO0 and start of serial transfer (writing to SIO0) is as follows:

- When the serial interface operation enable/disable bit (CSIE0) = 1. However, the case where CSIE0 is set to 1 after data is written to the shift register is excluded.
- When the serial clock is masked after 8-bit serial transfer
- $\overline{SCK0}$ is high.

When reading from or writing to SIO0, make sure that $\overline{SCK0}$ is high.

In the two-wire serial I/O mode and SBI mode, the pins specified for the data bus are used for both input and output. Because the configuration of output pins is N-ch open-drain, write FFH in SIO0 for devices that are to receive data.

(4) Slave address register (SVA)

The slave address register (SVA) is an 8-bit register for a slave to set its slave address (number assigned to it).

SVA is manipulated using an 8-bit manipulation instruction. SVA allows only write operation.

When the $\overline{\text{RESET}}$ signal is entered, the value of SVA is undefined. However, the value of SVA is preserved when the $\overline{\text{RESET}}$ signal is entered in the standby mode.

SVA has the following two functions:

(a) Slave address detection (in the SBI mode)

SVA is used when the $\mu\text{PD75518}$ is connected as a slave device to the serial bus. The master outputs a slave address to the connected slaves to select a particular slave. Two data values (a slave address output from the master and the value of SVA) are compared with each other by the address comparator. If a match is found, the slave is selected.

At this time, bit 6 (COI) of serial operation mode register 0 (CSIM0) is set to 1.

If a match with received address data is not found, the bus release detection flag (RELD) is cleared to 0. When $\text{WUP} = 1$ (wake-up state detection), IRQCSI0 is set only when a match is found. With this interrupt request, the $\mu\text{PD75518}$ can be informed of a communication request transmitted from the master.

(b) Error detection (In the two-wire serial I/O mode or SBI mode)

SVA detects an error in either of the following cases:

- When addresses, commands, or data is transferred with the $\mu\text{PD75518}$ operating as the master
- When data is transferred with the $\mu\text{PD75518}$ operating as a slave

For details, see (6) in **Section 5.7.6** and (8) in **Section 5.7.7**.

5.7.4 Operation Halt Mode

The operation halt mode is used when serial transfer is not performed. This mode reduces power consumption.

The shift register does not perform shift operation in this mode, so the shift register can be used as a normal 8-bit register.

When the $\overline{\text{RESET}}$ signal is entered, the operation halt mode is set. The P02/SO0/SB0 pin and P03/SI0/SBI pin function as input-only port pins. The P01/ $\overline{\text{SCK0}}$ pin can be used as an input port pin by setting the serial operation mode register.

[Register setting]

To set the operation halt mode, manipulate serial operation mode register 0 (CSIM0). (For details on CSIM0, see (1) in Section 5.7.3.)

CSIM0 is manipulated with an 8-bit manipulation instruction. Only the CSIE0 bit of CSIM0 can be independently manipulated. CSIM0 can also be manipulated using the name of each bit.

When the $\overline{\text{RESET}}$ signal is entered, CSIM0 is set to 00H.

In the figure below, hatched portions indicate bits used in the operation halt mode.

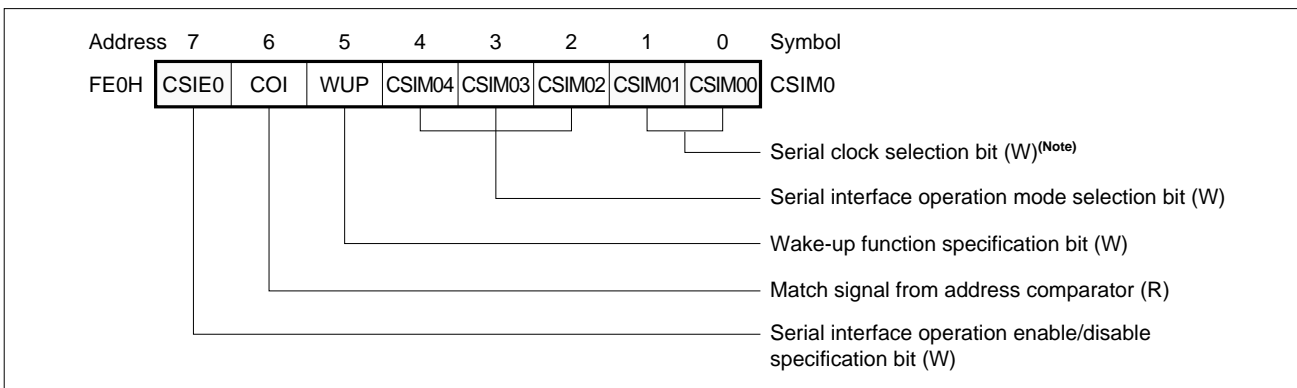

(Note) The status of the P01/ $\overline{\text{SCK0}}$ pin is selectable.

Remark (R) : Read only
(W) : Write only

Serial interface operation enable/disable specification bit (W)

		Shift register operation	Serial clock counter	IRQCSI0 flag	SO0/SB0 and SI0/SB1 pins
CSIE0	0	Shift operation disabled	Cleared	Held	Used only for port 0

Serial clock selection bit (W)

The P01/ $\overline{\text{SCK0}}$ pin assumes the following state according to the setting of CSIM00 and CSIM01:

CSIM01	CSIM00	P01/ $\overline{\text{SCK0}}$ pin state
0	0	High impedance
0	1	High level output
1	0	
1	1	

When clearing CSIE0 during serial transfer, use the following procedure:

- <1> Disable interrupts by clearing the interrupt enable flag (IECSI0).
- <2> Clear CSIE0.
- <3> Clear the interrupt request flag (IRQCSI0).

5.7.5 Three-Wire Serial I/O Mode Operations

The three-wire serial I/O mode is compatible with other modes used in the 75X series, μ PD7500 series, and 78K series.

Communication is performed using three lines:

Serial clock ($\overline{\text{SCK0}}$), serial output (SO0), and serial input (SI0).

Figure 5-44. Example of Three-Wire Serial I/O System Configuration

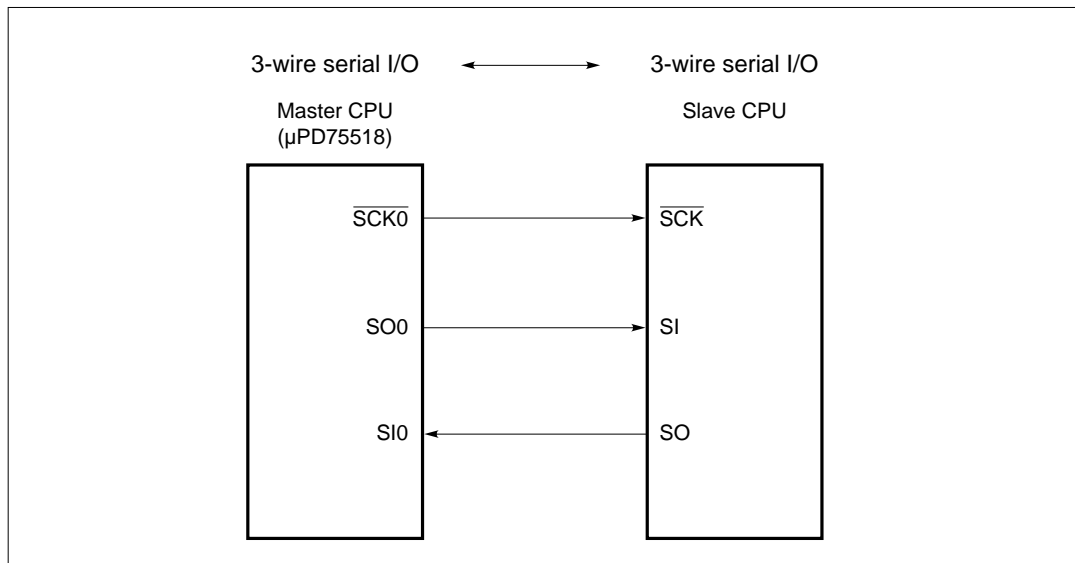

Remark The μ PD75518 can also be used as a slave CPU.

(1) Register setting

To set the three-wire serial I/O mode, manipulate the following two registers:

- Serial operation mode register 0 (CSIM0)
- Serial bus interface control register (SBIC)

(a) Serial operation mode register 0 (CSIM0)

To use the three-wire serial I/O mode, set CSIM0 as shown below. (For details on CSIM0, see (1) in Section 5.7.3.)

CSIM0 is manipulated using an 8-bit manipulation instruction. Bits 7, 6, and 5 of CSIM0 can be manipulated bit by bit.

When the $\overline{\text{RESET}}$ signal is input, CSIM0 is set to 00H.

In the figure below, hatched portions indicate the bits used in the three-wire serial I/O mode.

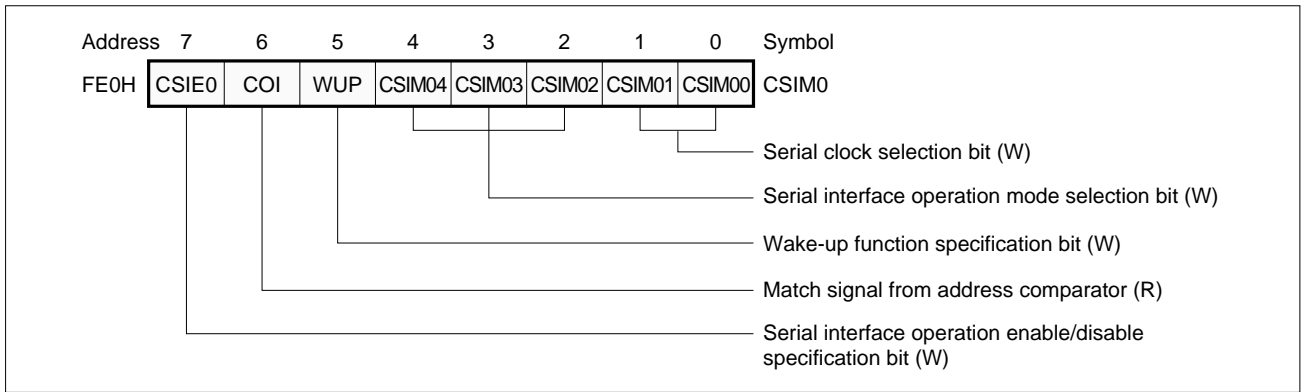

Remark (R) : Read only
(W) : Write only

Serial clock selection bit (W)

CSIM01	CSIM00	Serial clock	$\overline{\text{SCK0}}$ pin mode
0	0	External clock applied to $\overline{\text{SCK0}}$ pin	Input
0	1	Timer/event counter output (T0)	Output
1	0	$f_x/2^4$ (262 kHz or 375 kHz)(Note)	
1	1	$f_x/2^3$ (524 kHz or 750 kHz)(Note)	

(Note) The values at 4.19 MHz and 6.0 MHz are indicated in parentheses.

Serial interface operation mode selection bit (W)

CSIM04	CSIM03	CSIM02	Shift register sequence	SO0 pin function	SI0 pin function
x	0	0	SIO ₇₋₀ \leftrightarrow XA (Transfer starting with MSB)	SO0/P02 (CMOS output)	SI0/P03 (Input)
		1	SIO ₀₋₇ \leftrightarrow XA (Transfer starting with LSB)		

Remark x: Don't care

Wake-up function specification bit (W)

WUP	0	Sets IRQCSI0 each time serial transfer is completed.
-----	---	--

Signal from address comparator (R)

COI(Note)	Condition for being cleared (COI = 0)	Condition for being set (COI = 1)
	When the slave address register (SVA) does not match the data of the shift register	When the slave address register (SVA) matches the data of the shift register

(Note) COI can be read only before serial transfer is started or after serial transfer is completed. An undefined value may be read during transfer. COI data written by an 8-bit manipulation instruction is ignored.

Serial interface operation enable/disable specification bit (W)

		Shift register operation	Serial clock counter	IRQCSI0 flag	SO0/SB0, SI0/SB1 pin
CSIE0	1	Shift operation enabled	Count operation	Can be set	Used in each mode as well as for port 0

(b) Serial bus interface control register (SBIC)

To use the three-wire serial I/O mode, set SBIC as shown below. (For details on SBIC, see (2) in Section 5.7.3.)

SBIC is manipulated using a bit memory manipulation instruction.

When the $\overline{\text{RESET}}$ signal is input, SBIC is set to 00H.

In the figure below, hatched portions indicate the bits used in the three-wire serial I/O mode.

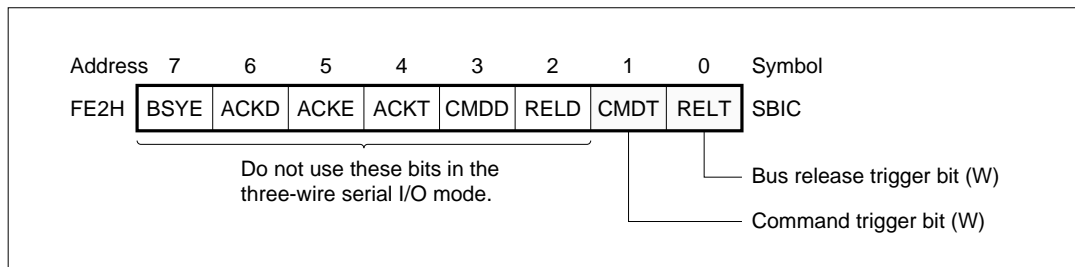

Remark (W): Write only

Bus release trigger bit (W)

RELT	Control bit for bus release signal (REL) trigger output. By setting RELT = 1, the SO0 latch is set to 1. Then the RELT bit automatically cleared to 0.
------	--

Command trigger bit (W)

CMDT	Control bit for command signal (CMD) trigger output. By setting CMDT = 1, the SO0 latch is cleared. Then the CMDT bit is automatically cleared.
------	---

Caution Never use bits other than RELT and CMDT in the three-wire serial I/O mode.

(2) Communication operation

The three-wire serial I/O mode transfers data, with eight bits as one block. Data is transferred bit by bit in phase with the serial clock.

The shift register performs shift operation on the falling edge of the serial clock ($\overline{SCK0}$). Send data is latched on the SO0 latch, and is output on the SO0 pin. Receive data applied to the SIO pin is latched in the shift register on the rising edge of $\overline{SCK0}$.

When eight bits have been transferred, shift register operation automatically terminates setting the interrupt request flag (IRQCSI0).

Figure 5-45. Timing of Three-Wire Serial I/O Mode

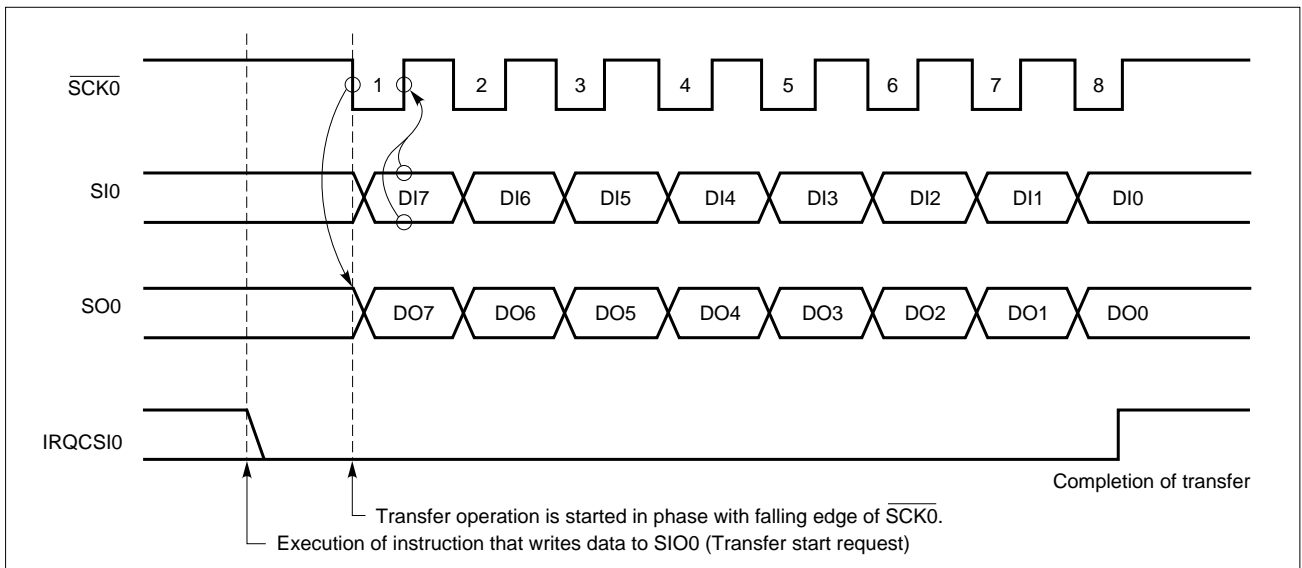

The SO0 pin becomes a CMOS output and outputs the state of the SO0 latch. So the output state of the SO0 pin can be manipulated by setting the RELT bit and CMDT bit.

However, this manipulation must not be performed during serial transfer.

The output level of the $\overline{SCK0}$ pin can be controlled by manipulating the P01 output latch in the output mode (internal system clock mode). (See **Section 5.7.8.**)

(3) Serial clock selection

To select the serial clock, manipulate bits 0 and 1 of serial operation mode register 0 (CSIM0). The serial clock can be selected out of the following four clocks:

Table 5-11. Serial Clock Selection and Application (In the Three-Wire Serial I/O Mode)

Mode register		Serial clock		Timing for shift register R/W and start of serial transfer	Application
CSIM0 1	CSIM0 0	Source	Masking of serial clock		
0	0	External $\overline{\text{SCK0}}$	Automatically masked when 8-bit data transfer is completed	<1> In the operation halt mode (CSIE0 = 0) <2> When the serial clock is masked after 8-bit transfer <3> When $\overline{\text{SCK0}}$ is high	Slave CPU
0	1	TOUT flip-flop			Half-duplex asynchronous transfer (software control)
1	0	$f_X/2^4$			Middle-speed serial transfer
1	1	$f_X/2^3$			High-speed serial transfer

(4) Signals

Figure 5-46 shows operations of RELT and CMDT.

Figure 5-46. Operations of RELT and CMDT

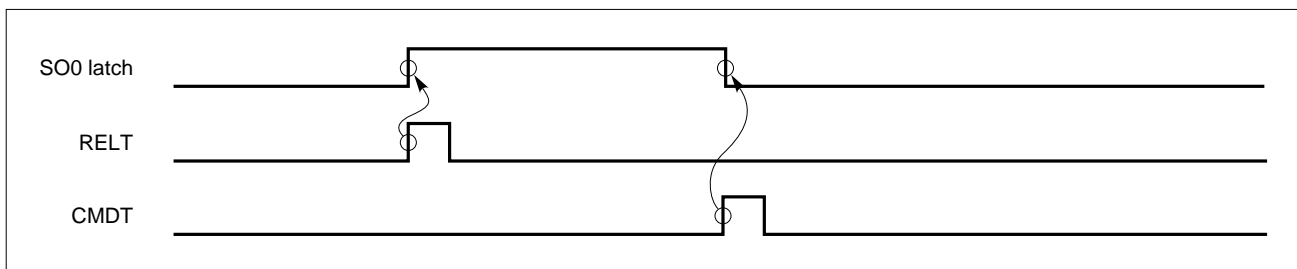

(5) Switching between MSB and LSB as the first transfer bit

The three-wire serial I/O mode has a function that can switch between the MSB and LSB as the first bit of transfer.

Figure 5-47 shows the configuration of shift register 0 (SIO0) and internal bus. As shown in Figure 5-47, read or write operation can be performed by switching between the MSB and LSB.

This switching can be specified using bit 2 of serial operation mode register 0 (CSIM0).

Figure 5-47. Transfer Bit Switching Circuit

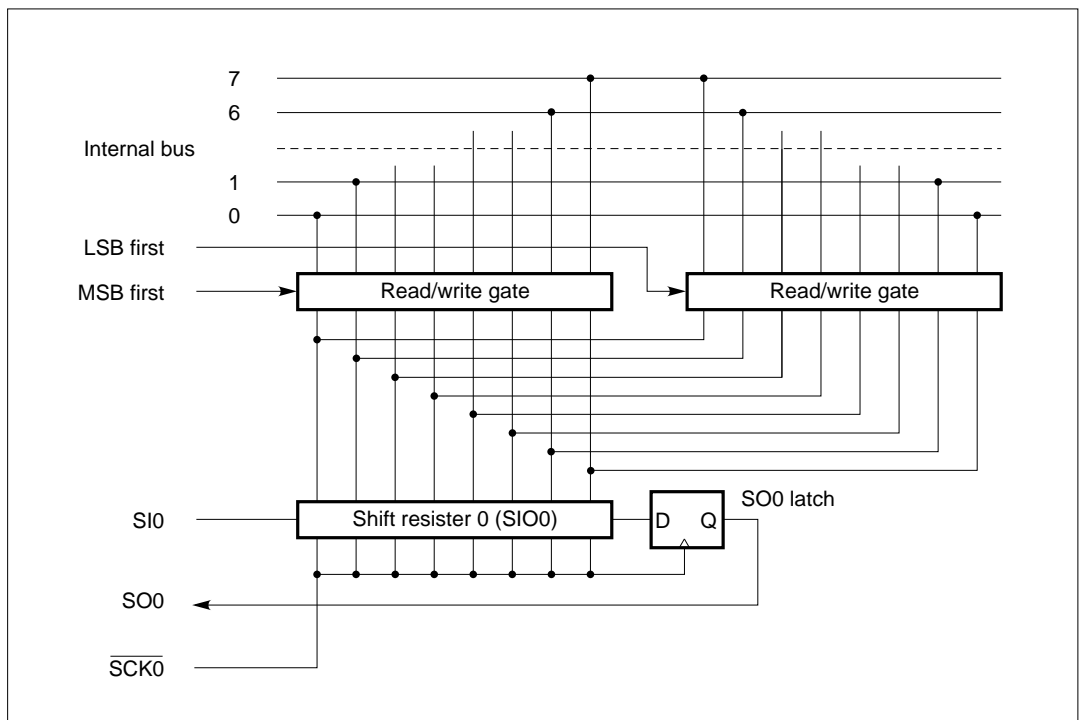

The first bit is switched by changing the order of data bits written to shift register 0 (SIO0). The shift operation order of SIO0 is always the same.

Accordingly, the first bit must be switched between the MSB and LSB before writing data to the shift register.

(6) Transfer start

Serial transfer is started by writing transfer data into shift register 0 (SIO0), provided that the following two conditions are satisfied:

- The serial interface operation enable/disable specification bit (CSIE0) is set to 1.
- The internal serial clock is not operating after 8-bit serial transfer, or $\overline{\text{SCK0}}$ is high.

Caution **Setting CSIE0 after writing data to the shift register does not start transfer.**

When eight bits have been transferred, serial transfer automatically terminates setting the interrupt request flag (IRQCSI0).

Example To transfer the RAM data specified with the HL register to SIO0, load the SIO0 data to the accumulator and start serial transfer:

```
MOV  XA,@HL ; Fetch transmit data from RAM
```

```
SEL  MB15    ; or CLR1 MBE
```

```
XCH  XA,SIO0 ; Exchange transmit data and receive data, and start transfer
```

(7) Application of the three-wire serial I/O mode

Example 1. Data is transferred starting with the MSB on a transfer clock of 262 kHz (in 4.19-MHz operation). (Master operation)

<Sample program>

```

CLR1  MBE
MOV   XA,#10000010B
MOV   CSIM0,XA      ; Set transfer mode
MOV   XA,TDATA      ; TDATA is transfer data storage address
MOV   SIO0,XA       ; Set transfer data, and start transfer
    
```

Caution **A second or subsequent transfer can be started by setting data in SIO0 (MOV SIO0,XA or XCH XA,SIO0).**

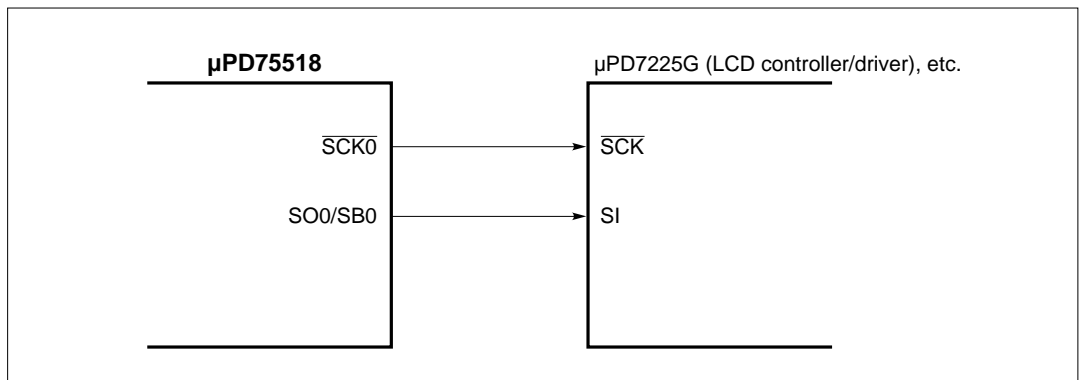

In this case, the SIO/SBI pin on the μPD75518 can be used as an input.

Example 2. Data is transmitted and received starting with the LSB on an external clock (slave operation).

(In this case, the function of inverting the MSB/LSB is used for shift register read/write operation.)

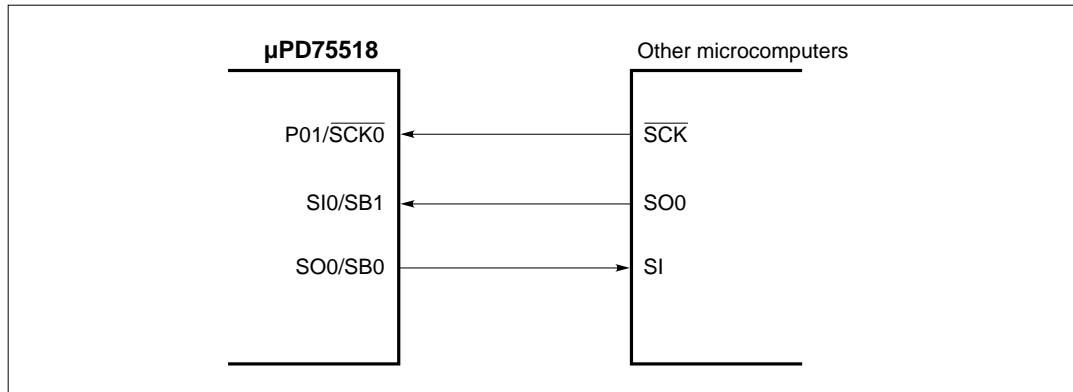

<Sample program>

Main routine

```
CLR1  MBE
```

```
MOV   XA,#84H
```

```
MOV   CSIM0,XA ; Serial operation halt, MSB/LSB invert mode, external clock
```

```
MOV   XA,TDATA
```

```
MOV   SIO0,XA ; Set transfer data, and start transfer
```

```
EI    IECSI0
```

```
EI
```

Interrupt routine (MBE = 0)

```
MOV   XA,TDATA
```

```
XCH   XA,SIO0 ; Exchange receive data with transmit data, and start transfer
```

```
MOV   RDATA,XA ; Save receive data
```

```
RETI
```

Example 3. Data is transmitted and received at high speed by using a transfer clock of 524 kHz (at 4.19 MHz).

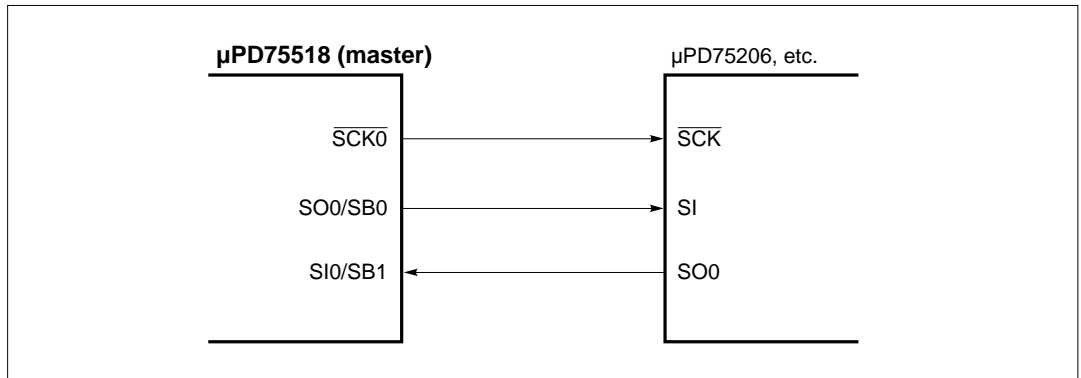

<Sample program> (master side):

```

    CLR1    MBE
    MOV     XA,#10000011B
    MOV     CSIM0,XA      ; Set transfer mode
    MOV     XA,TDATA
    MOV     SIO0,XA      ; Set transfer data, and start transfer
    .
    .
    .
    LOOP : SKTCLR  IRQCSI0    ; Test IRQCSI0
    BR     LOOP
    MOV     XA,SIO0      ; Read in receive data
  
```

5.7.6 Two-Wire Serial I/O Mode

The two-wire serial I/O mode can be made compatible with any communication format by programming.

In this mode, communication is basically performed using two lines: Serial clock ($\overline{SCK0}$) and serial data input/output (SB0 or SB1).

Figure 5-48. Example of Two-Wire Serial I/O System Configuration

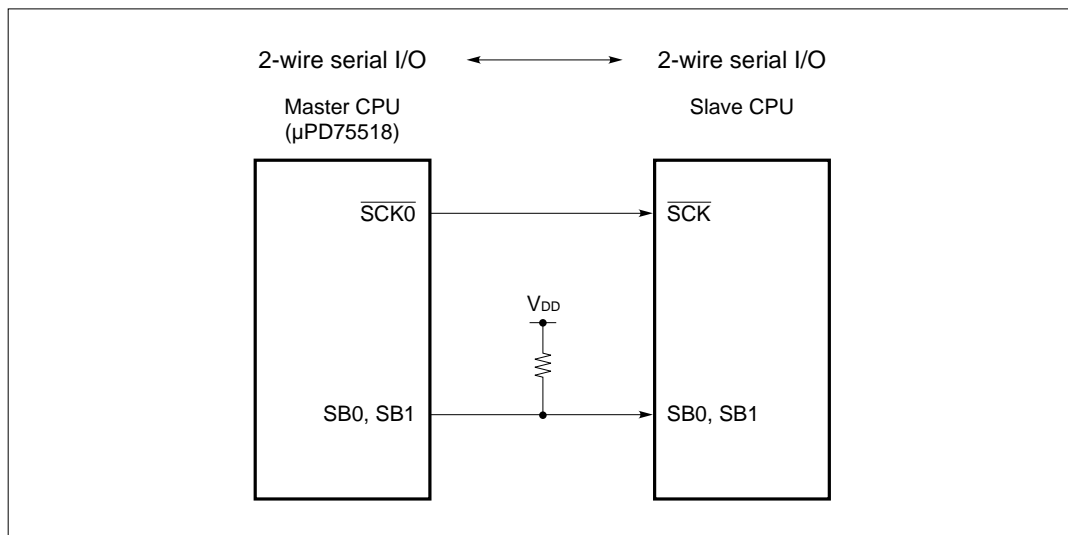

Remark The μ PD75518 can also be used as a slave CPU.

(1) Register setting

To set the two-wire serial I/O mode, manipulate the following two registers:

- Serial operation mode register 0 (CSIM0)
- Serial bus interface control register (SBIC)

(a) Serial operation mode register 0 (CSIM0)

To use the two-wire serial I/O mode, set CSIM0 as shown below. (For details on CSIM0, see (1) in Section 5.7.3.)

CSIM0 is manipulated using an 8-bit manipulation instruction. Bits 7, 6, and 5 of CSIM0 can be manipulated bit by bit.

When the \overline{RESET} signal is input, CSIM0 is set to 00H.

In the figure below, hatched portions indicate the bits used in the two-wire serial I/O mode.

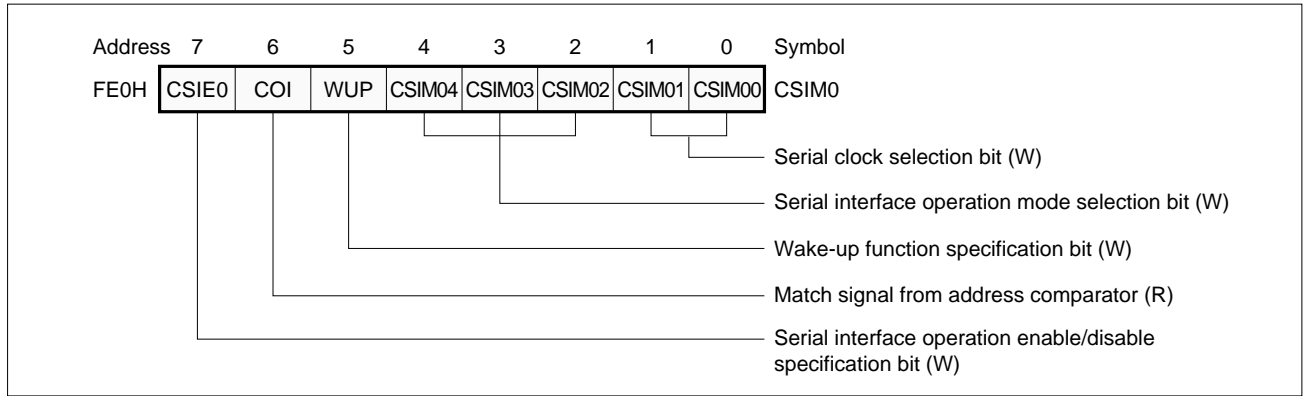

Remark (R) : Read only
(W) : Write only

Serial clock selection bit (W)

CSIM01	CSIM00	Serial clock	$\overline{\text{SCK0}}$ pin mode
0	0	External clock applied to $\overline{\text{SCK0}}$ pin	Input
0	1	Timer/event counter output (T0)	Output
1	0	$f_x/2^6$ (65.5 kHz or 93.8 kHz) (Note)	
1	1		

(Note) The values at 4.19 MHz and 6.0 MHz are indicated in parentheses.

Serial interface operation mode selection bit (W)

CSIM04	CSIM03	CSIM02	Shift register sequence	SO0 pin function	SI0 pin function
0	1	1	SIO0 ₇₋₀ \leftrightarrow XA (Transfer starting with MSB)	SB0/P02 (N-ch open-drain I/O)	P03 input
1				P02 input	SB1/P03 (N-ch open-drain I/O)

Wake-up function specification bit (W)

WUP	0	Sets IRQCSI0 each time serial transfer is completed.
-----	---	--

Signal from address comparator (R)

COI(Note)	Condition for being cleared (COI = 0)	Condition for being set (COI = 1)
	When the slave address register (SVA) does not match the data of the shift register	When the slave address register (SVA) matches the data of the shift register

(Note) COI can be read only before serial transfer is started or after serial transfer is completed. An undefined value may be read during transfer. COI data written by an 8-bit manipulation instruction is ignored.

Serial interface operation enable/disable specification bit (W)

		Shift register operation	Serial clock counter	IRQCSI0 flag	SO0/SB0, SI0/SB1 pin
CSIE0	1	Shift operation enabled	Count operation	Can be set	Used in each mode as well as for port 0

(b) Serial bus interface control register (SBIC)

To use the two-wire serial I/O mode, set SBIC as shown below. (For details on SBIC, see (2) in Section 5.7.3.)

SBIC is manipulated using a bit manipulation instruction.

When the $\overline{\text{RESET}}$ signal is input, SBIC is set to 00H.

In the figure below, the hatched portions indicate the bits used in the two-wire serial I/O mode.

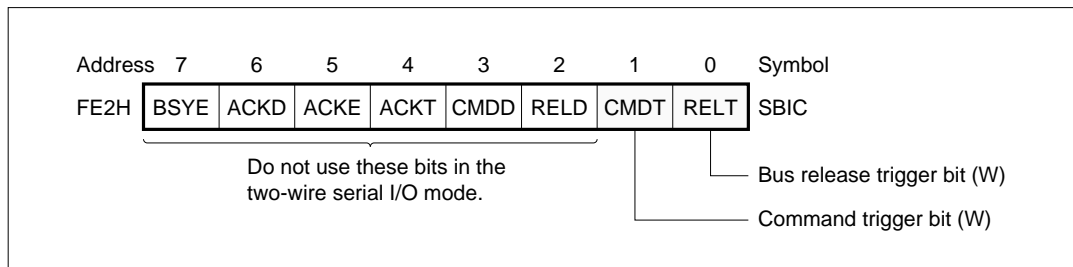

Remark (W): Write only

Bus release trigger bit (W)

RELT	Control bit for bus release signal (REL) trigger output. By setting RELT = 1, the SO0 latch is set to 1. Then the RELT bit automatically cleared to 0.
------	--

Command trigger bit (W)

CMDT	Control bit for command signal (CMD) trigger output. By setting CMDT = 1, the SO0 latch is cleared. Then the CMDT bit is automatically cleared.
------	---

Caution **Never use bits other than RELT and CMDT in the two-wire serial I/O mode.**

(2) Communication operation

The two-wire serial I/O mode transfers data, with eight bits as one block. Data is transferred bit by bit in phase with the serial clock.

The shift register performs shift operation on the falling edge of the serial clock ($\overline{SCK0}$). Transmit data is latched on the SO0 latch, and is output on the SB0/P02 pin or SB1/P03 pin starting with the MSB. Receive data applied to the SB0 pin or SB1 pin is latched in the shift register on the rising edge of $\overline{SCK0}$.

When eight bits have been transferred, shift register operation automatically terminates setting the interrupt request flag (IRQCSI0).

Figure 5-49. Timing of Two-Wire Serial I/O Mode

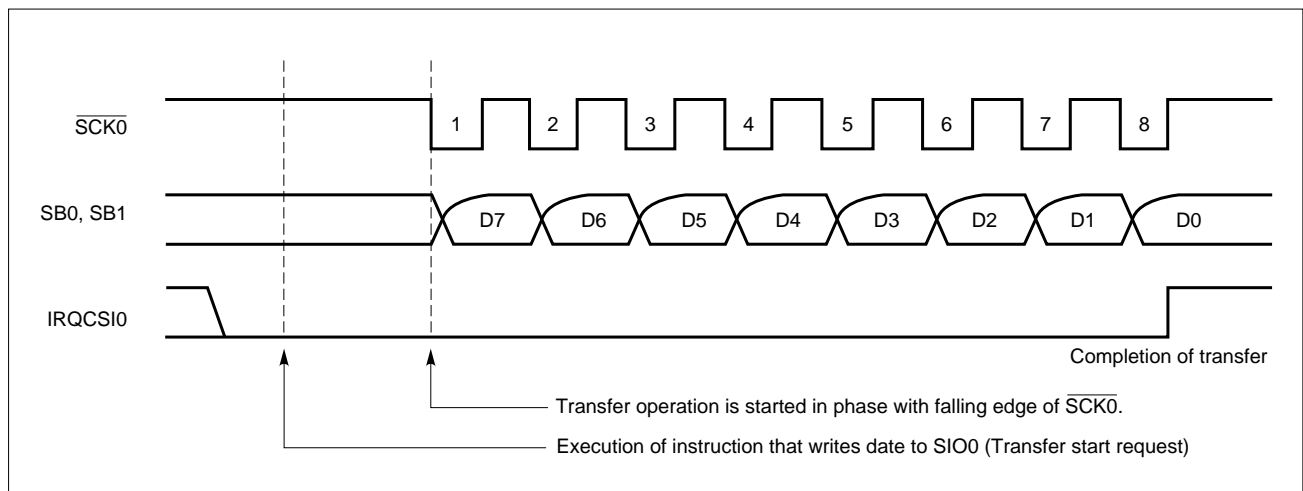

The SB0 or SB1 pin becomes an N-ch open-drain I/O when specified as the serial data bus, so the voltage level on that pin must be pulled up externally. When data is received, the N-ch transistor must be turned off, so FFH must be written to SIO0 beforehand.

The state of the SO0 latch is output on the SB0/SB1 pin, so the SB0/SB1 pin output states can be controlled by setting the RELT or CMDT bit.

However, this operation must not be performed during serial transfer.

The output level of the $\overline{SCK0}$ pin can be controlled by manipulating the P01 output latch in the output mode (internal system clock mode). (See **Section 5.7.8.**)

(3) Serial clock selection

To select the serial clock, manipulate bits 0 and 1 of serial operation mode register 0 (CSIM0). The serial clock can be selected out of the following three clocks:

Table 5-12. Serial Clock Selection and Application (In the Two-Wire Serial I/O Mode)

Mode register		Serial clock		Timing for shift register R/W and start of serial transfer	Application
CSIM0	CSIM0	Source	Masking of serial clock		
1	0				
0	0	External $\overline{\text{SCK0}}$	Automatically masked when	<1> In the operation halt mode (CSIE0 = 0)	Slave CPU
0	1	TOUT flip-flop	8-bit data transfer is completed	<2> When the serial clock is masked after 8-bit transfer	Arbitrary-speed serial transfer
1	0	$f_x/2^6$		<3> When $\overline{\text{SCK0}}$ is high	Low-speed serial transfer
1	1				

(4) Signals

Figure 5-50 shows operations of RELT and CMDT.

Figure 5-50. Operations of RELT and CMDT

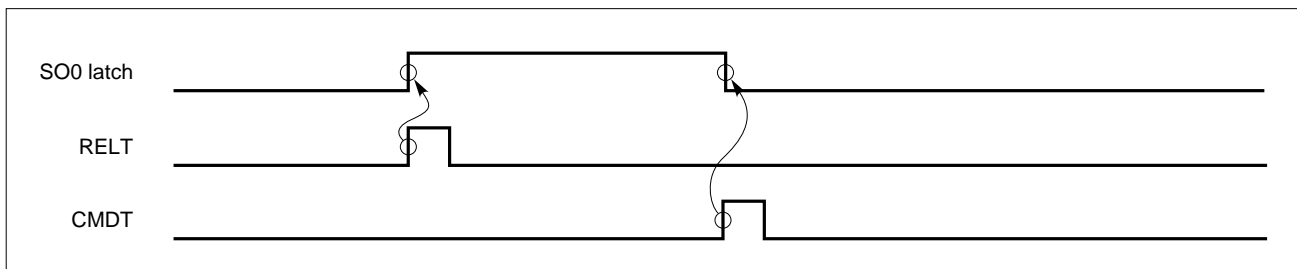

(5) Transfer start

Serial transfer starts by writing transfer data into shift register 0 (SIO0), provided that the following two conditions are satisfied:

- The serial interface operation enable/disable specification bit (CSIE0) is set to 1.
- The internal serial clock is not operating after 8-bit serial transfer, or $\overline{\text{SCK0}}$ is high.

-
- Cautions 1. Setting CSIE0 to 1 after writing data to the shift register does not start transfer.**
- 2. When data is received, the N-ch transistor must be turned off, so FFH must be written to SIO0 beforehand.**
-

When eight bits have been transferred, serial transfer automatically terminates setting the interrupt request flag (IRQCSI0).

(6) Error detection

In the two-wire serial I/O mode, the state of serial bus SB0 or SB1 being used for communication is loaded into the shift register (SIO0) of the transmitting device. So a transmission error can be detected by the methods described below.

(a) Comparing SIO0 data before start of transmission with SIO0 data after start of transmission

With this method, the occurrence of a transmission error is assumed when two SIO0 values disagree with each other.

(b) Using the slave address register (SVA)

Transmit data is set in SIO0 and SVA as well before the data is transmitted. On completion of transmission, the COI bit (match signal from the address comparator) of serial operation mode register 0 (CSIM0) is tested. If the result is 1, the transmission is regarded as successful. If the result is 0, the occurrence of a transmission error is assumed.

(7) Application of two-wire serial I/O mode

A serial bus is configured, and multiple devices are connected to it.

Example A system is configured with a μ PD75518 as the master to which a μ PD75104, μ PD75402A, and μ PD7225G are connected as slaves.

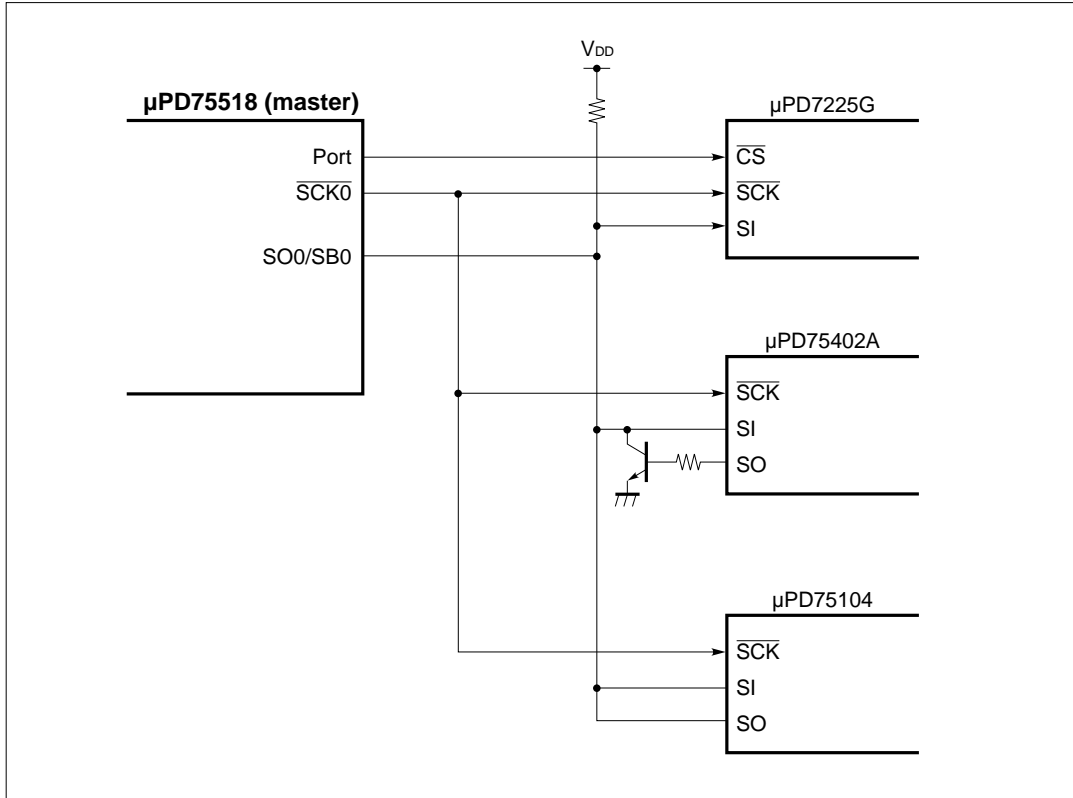

The μ PD75104 connects the SI and SO pins, manipulates the serial operation mode register except when serial data is output, and frees the bus by setting off the output buffer.

The SO pin of the μ PD75402A cannot go into a high-impedance state, so that a transistor must be connected as shown in the figure to make open collector output appear on the pin. When data is input, 00H must be set beforehand in the shift register to set the transistor off.

The timing of data output by each microcomputer must be predetermined.

The μ PD75518, which is the master microcomputer, outputs a serial clock, and all slave microcomputers operate with an external clock.

5.7.7 SBI Mode Operation

The SBI (serial bus interface) is a high-speed serial interface that conforms to the NEC serial bus format.

To allow communication with multiple devices on a single-master and high-speed serial bus using two signal lines, the SBI has a bus configuration function added to the clock synchronous serial I/O method. So the SBI can reduce ports and wires on boards when multiple microcomputers and peripheral ICs are used to configure a serial bus.

The master can output, on the serial data bus, an address for selecting a device subject to serial communication, commands directed to the remote device, and data. A slave can identify an address, commands, and data from received data by hardware. This function simplifies the serial interface (channel 0) control portion of an application program.

The SBI function is available with devices such as the 75X series and 78K series 8- and 16-bit single chip microcomputers.

Figure 5-51 is an example of the SBI system configuration when the CPU with a serial interface conforming to SBI or peripheral ICs are used.

In the SBI mode, the serial data bus pin SB0 or SB1 is an open-drain output. So the serial data bus line is placed in the wired OR state. A pull-up resistor is required for the serial data bus line.

Figure 5-51. Example of SBI System Configuration

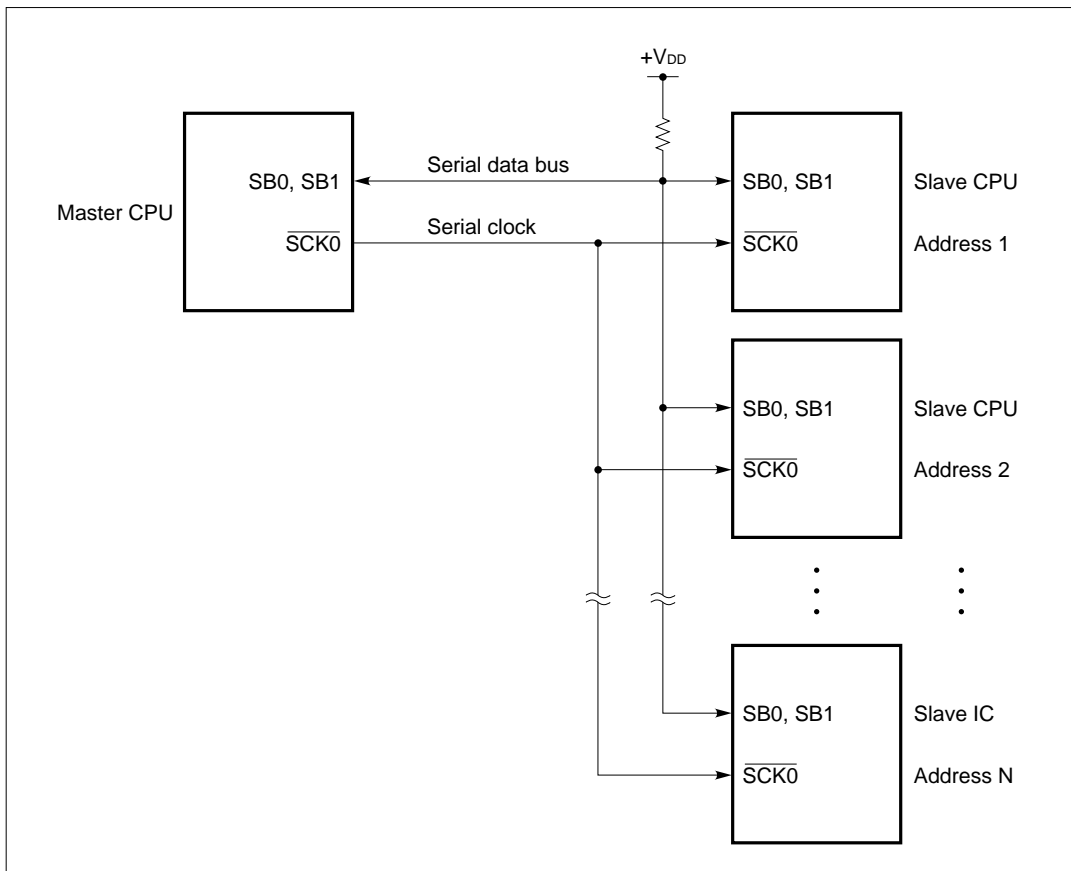

Caution To switch between the master and slave, a pull-up resistor is required also for the serial clock line (SCK0), because SCK0 input/output switching is performed between the master and slave asynchronously.

(1) SBI functions

Conventional serial I/O methods provide only data transfer functions. Therefore, many ports and wires are required to identify chip select signals, commands, and data, and to detect busy states, when the serial bus is configured with multiple devices. Also, these processes are too burdensome to be controlled by software.

The SBI method can configure a serial bus with two signal lines: Serial clock $\overline{SCK0}$ and serial data bus SB0 or SB1. For this reason, the number of ports on a microcomputer can be reduced and the wiring on a circuit board can be simplified.

SBI functions are described below.

(a) Address/command/data identification function

Serial data is classified into three types: Address, command, and data.

(b) Address-based chip select function

The master selects a chip for a slave by address transfer.

(c) Wake-up function

A slave can easily check address reception (for chip select identification) with the wake-up function. This function can be set or released by software.

When the wake-up function is set, an interrupt (IRQCSI0) is generated when a match address is received.

For this reason, in communication with multiple devices, a CPU other than a selected slave can operate independently of serial communication.

(d) Acknowledge signal (\overline{ACK}) control function

The acknowledge signal, which is used to confirm the reception of serial data, can be controlled.

(e) Busy signal (\overline{BUSY}) control function

The busy signal, which is used to post the busy state of a slave, can be controlled.

(2) SBI definition

The format of serial data and signal used in the SBI mode are described below.

Serial data to be transferred in the SBI mode is classified into three types: Address, command, and data.

Figure 5-52 is a timing chart for transferring address, command, and data.

Figure 5-52. Timing of SBI Transfer

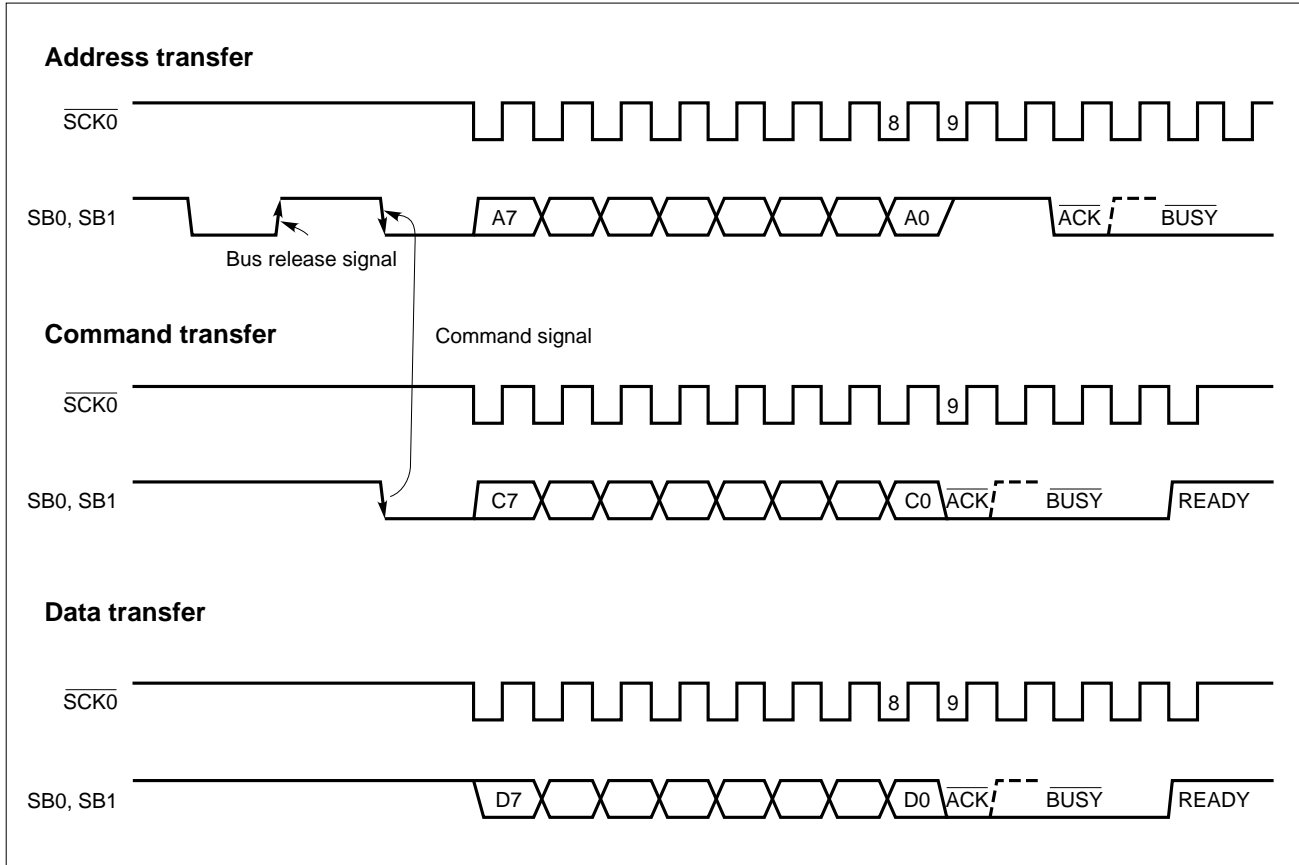

The bus release signal and command signal are output by the master. $\overline{\text{BUSY}}$ is output by a slave. $\overline{\text{ACK}}$ is output by either the master or a slave. (Normally, the device which received 8-bit data outputs $\overline{\text{ACK}}$.)

The master continues to output the serial clock from when 8-bit data transfer starts to when $\overline{\text{BUSY}}$ is released.

(a) Bus release signal (REL)

When the $\overline{\text{SCK0}}$ line is high (the serial clock is not output), the SB0 or SB1 line changes from low to high. This signal is called the bus release signal, and is output by the master.

Figure 5-53. Bus Release Signal

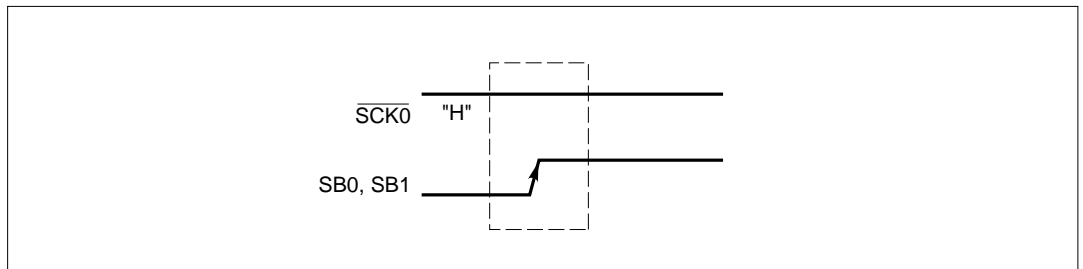

This signal indicates that the master is to send an address to a slave. Slaves contain hardware to detect the bus release signal.

(b) Command signal (CMD)

When the $\overline{\text{SCK0}}$ line is high (the serial clock is not output), the SB0 or SB1 line changes from high to low. This signal is called the command signal, which is output by the master.

Figure 5-54. Command Signal

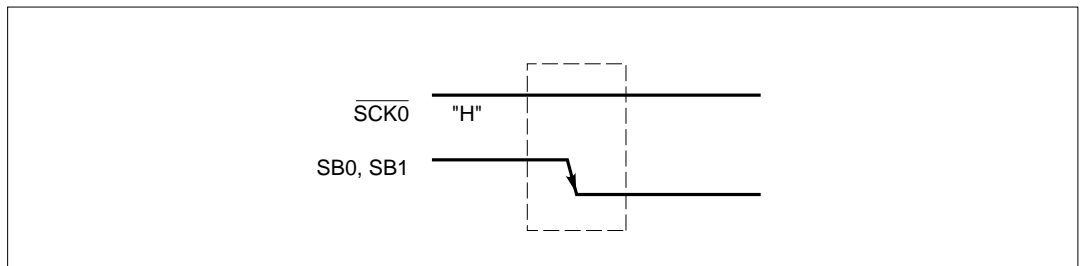

Slaves contain hardware to detect the command signal.

(c) Address

An address is 8-bit data and is output by the master to connected slaves to select a particular slave.

Figure 5-55. Address

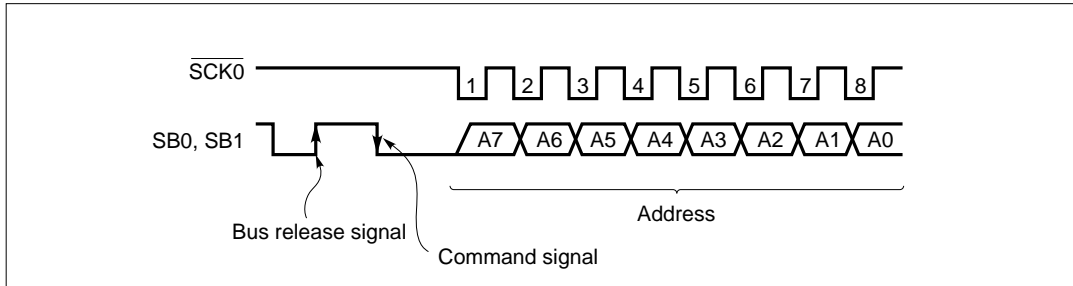

The 8-bit data following the bus release signal or command signal is defined as an address. A slave detects the condition for the addresses by hardware, and checks whether the 8-bit data matches the number assigned to the slave (slave address). If the 8-bit data matches the slave address, that slave is selected. The selected slave continues to communicate with the master until disconnection is directed by the master.

Figure 5-56. Slave Selection Using an Address

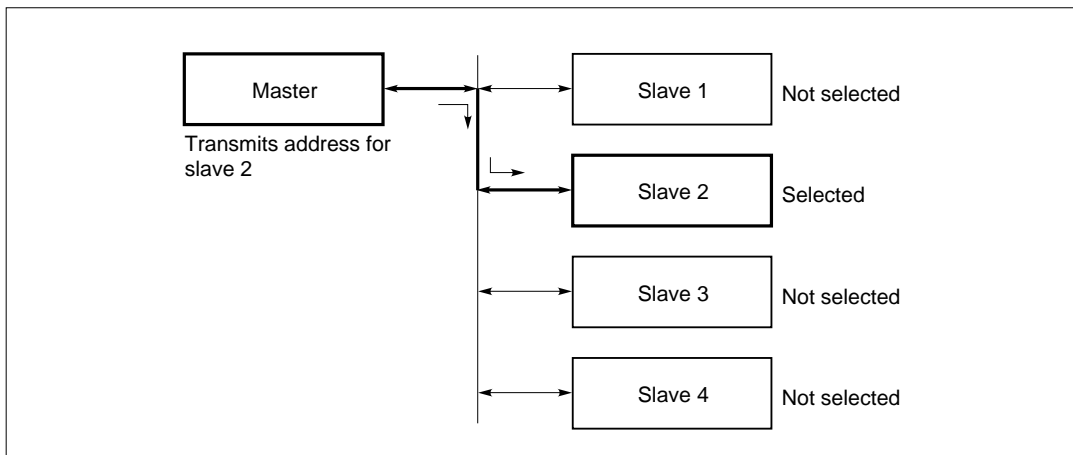

(d) Command and data

The master sends commands to the slave selected by sending an address. The master also transfers data to or from the slave.

Figure 5-57. Command

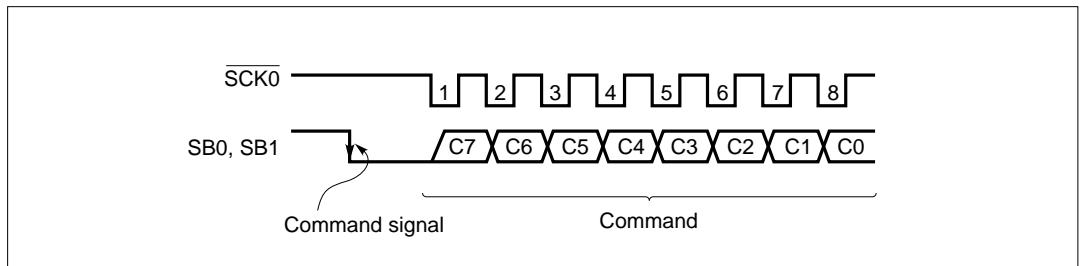
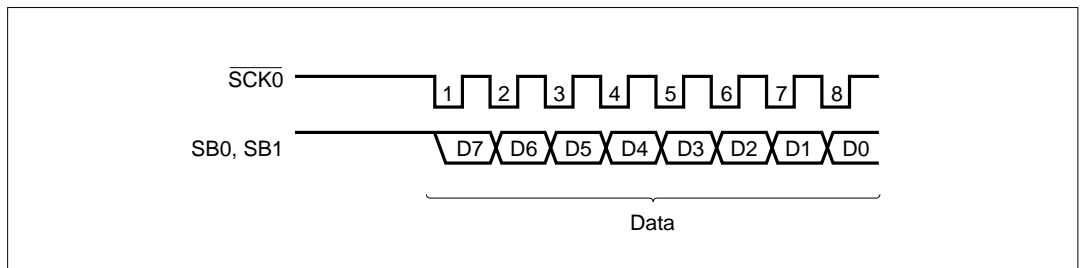

Figure 5-58. Data



The 8-bit data following the command signal is defined as a command. The 8-bit data without the command signal is defined as data. The usage of commands or data can be selected optionally according to the communication specifications.

(e) Acknowledge signal ($\overline{\text{ACK}}$)

The acknowledge signal confirms the reception of serial data between the transmitter and the receiver.

Figure 5-59. Acknowledge Signal

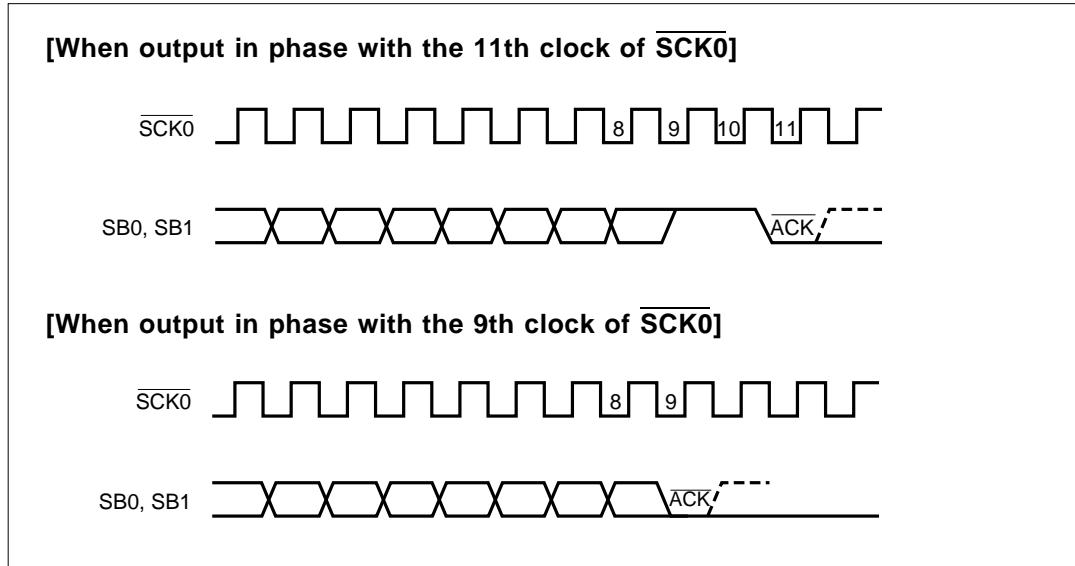

The acknowledge signal is a one-shot pulse output in phase with the falling edge of $\overline{\text{SCK0}}$ after 8-bit data transfer. This signal may be synchronized with any clock of $\overline{\text{SCK0}}$.

The transmitter checks if the receiver returns the acknowledge signal after 8-bit data transfer. If the acknowledge signal is not returned after a specified period of time, the transmitter can assume that the reception failed.

(f) **Busy signal ($\overline{\text{BUSY}}$) and ready signal ($\overline{\text{READY}}$)**

The busy signal informs the master that a slave is getting ready for data transfer.

The ready signal informs the master that a slave is ready for data transfer.

Figure 5-60. Busy and Ready Signals

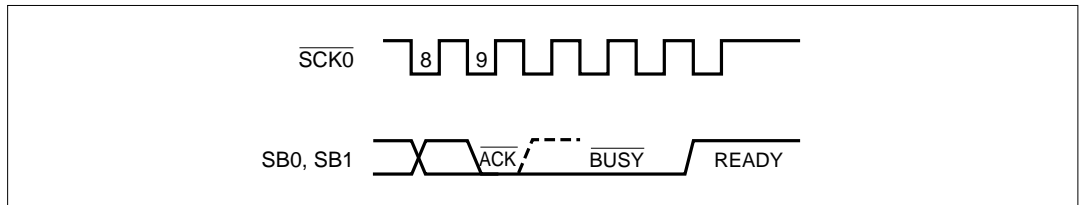

In the SBI mode, a slave notifies the master of the busy state by changing SB0 or SB1 from high to low.

The busy signal is output following the acknowledge signal output by the master or a slave. The busy signal is set and released in phase with the falling edge of $\overline{\text{SCK0}}$. The master automatically terminates output of serial clock $\overline{\text{SCK0}}$ when the busy signal is released.

The master can transfer the next data when the busy signal is released and a slave enters the state in which the ready signal is to be output.

(3) Register setting

To set the SBI mode, manipulate the following two registers:

- Serial operation mode register 0 (CSIM0)
- Serial bus interface control register (SBIC)

(a) Serial operation mode register 0 (CSIM0)

To use the SBI mode, set CSIM0 as shown below. (For details on CSIM0, see **(1)** in **Section 5.7.3.**)

CSIM0 is manipulated using an 8-bit manipulation instruction. Bits 7, 6, and 5 of CSIM0 can be manipulated bit by bit.

When the $\overline{\text{RESET}}$ signal is input, CSIM0 is set to 00H.

In the figure below, hatched portions indicate the bits used in the SBI mode.

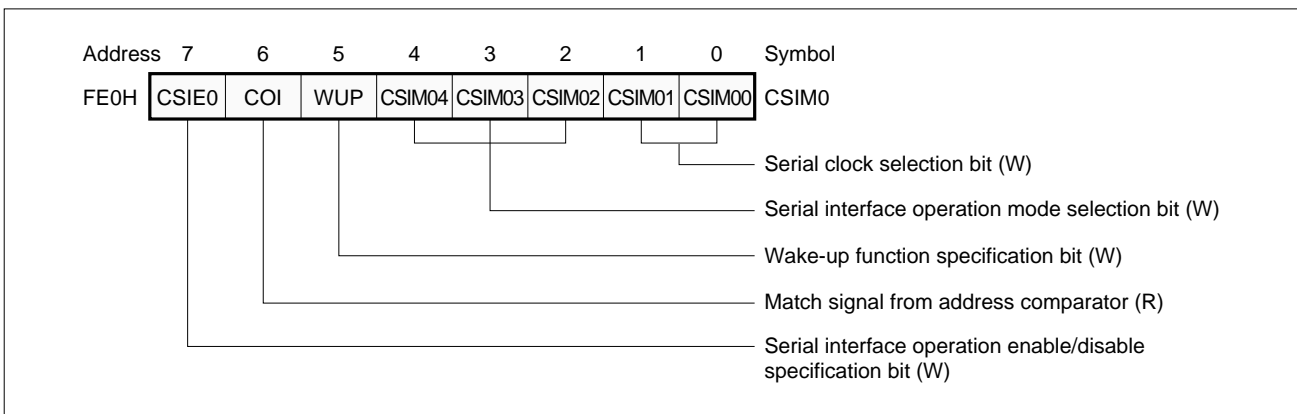

Remark (R) : Read only
(W) : Write only

Serial clock selection bit (W)

CSIM01	CSIM00	Serial clock	$\overline{\text{SCK0}}$ pin mode
0	0	External clock applied to $\overline{\text{SCK0}}$ pin	Input
0	1	Timer/event counter output (T0)	Output
1	0	$f_X/2^4$ (262 kHz or 375 kHz)(Note)	
1	1	$f_X/2^3$ (524 kHz or 750 kHz)(Note)	

(Note) The values at 4.19 MHz and 6.0 MHz are indicated in parentheses.

Serial interface operation mode selection bit (W)

CSIM04	CSIM03	CSIM02	Shift register sequence	SO0 pin function	SI0 pin function
0	1	0	SIO0 ₇₋₀ \longleftrightarrow XA (Transfer starting with MSB)	SB0/P02 (N-ch open-drain I/O)	P03 input
1				P02 input	SB1/P03 (N-ch open-drain I/O)

Wake-up function specification bit (W)

WUP	0	Sets IRQCSI0 each time serial transfer is completed in each mode.
	1	Used in the SBI mode only to set IRQCSI0 only when an address received after bus release matches the data in the slave address register (wake-up state). SB0/SB1 goes to high-impedance state.

Caution When $WUP = 1$ is set during \overline{BUSY} signal output, \overline{BUSY} is not released. In the SBI mode, the \overline{BUSY} signal is output until the next falling edge of the serial clock (SCK) appears after release of \overline{BUSY} is directed. Before setting $WUP = 1$, be sure to confirm that the SB0 (or SB1) pin is high after releasing \overline{BUSY} .

Signal from address comparator (R)

COI(Note)	Condition for being cleared (COI = 0)	Condition for being set (COI = 1)
	When the slave address register (SVA) does not match the data of the shift register	When the slave address register (SVA) matches the data of the shift register

(Note) COI can be read only before serial transfer is started or after serial transfer is completed. An undefined value may be read during transfer. COI data written by an 8-bit manipulation instruction is ignored.

Serial interface operation enable/disable specification bit (W)

		Shift register operation	Serial clock counter	IRQCSI0 flag	SO0/SB0, SI0/SB1 pin
CSIE0	1	Shift operation enabled	Count operation	Can be set	Used in each mode as well as for port 0

(b) Serial bus interface control register (SBIC)

To use the SBI mode, set SBIC as shown below. (For details on SBIC, see (2) in Section 5.7.3.)

SBIC is manipulated using a bit manipulation instruction.

When the $\overline{\text{RESET}}$ signal is input, SBIC is set to 00H.

In the figure below, hatched portions indicate the bits used in the SBI mode.

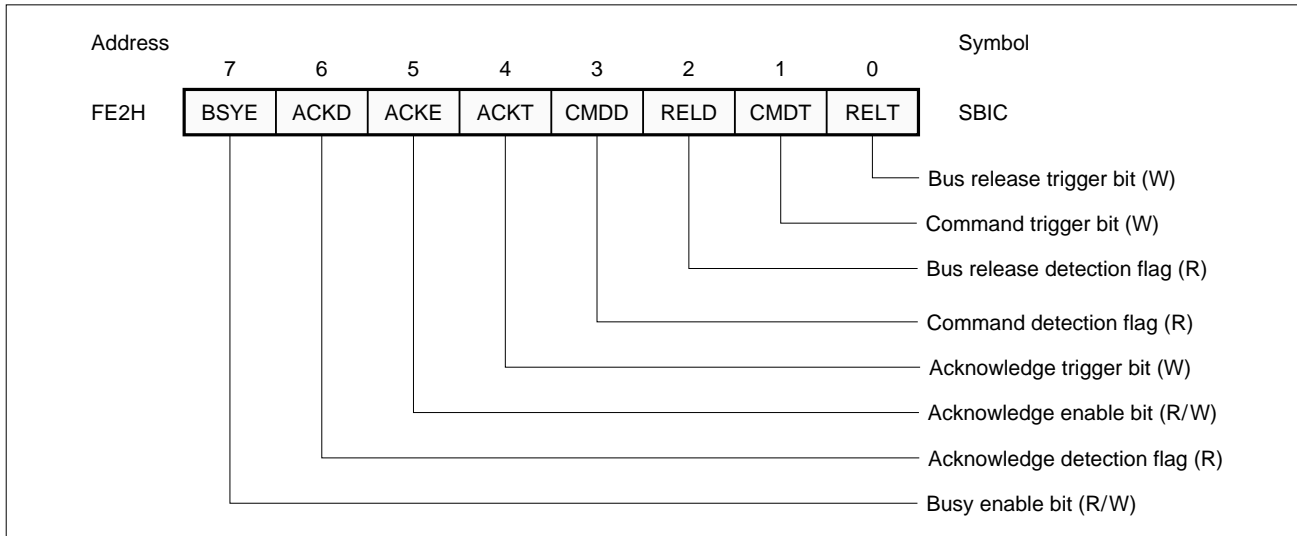

Remark (R) : Read only
(W) : Write only
(R/W): Read/write

Bus release trigger bit (W)

RELT	Control bit for bus release signal (REL) trigger output. By setting RELT = 1, the SO0 latch is set to 1. Then the RELT bit automatically cleared to 0.
------	--

Caution **Never clear SB0 (or SB1) during serial transfer. Be sure to clear SB0 (or SB1) before or after serial transfer.**

Command trigger bit (W)

CMDT	Control bit for command signal (CMD) trigger output. By setting CMDT = 1, the SO0 latch is cleared. Then the CMDT bit is automatically cleared.
------	---

Caution **Never clear SB0 (or SB1) during serial transfer. Be sure to clear SB0 (or SB1) before or after serial transfer.**

Bus release detection flag (R)

RELD	Condition for being cleared (RELD = 0)	Condition for being set (RELD = 1)
	<p><1> The transfer start instruction is executed.</p> <p><2> The $\overline{\text{RESET}}$ signal is entered.</p> <p><3> CSIE0 = 0 (Figure 5-41)</p> <p><4> SVA does not match SIO0 when an address is received.</p>	The bus release signal (REL) is detected.

Command detection flag (R)

CMDD	Condition for being cleared (CMDD = 0)	Condition for being set (CMDD = 1)
	<p><1> The transfer start instruction is executed.</p> <p><2> The bus release signal (REL)</p> <p><3> The $\overline{\text{RESET}}$ signal is entered.</p> <p><4> CSIE0 = 0 (Figure 5-41)</p>	The command signal (CMD) is detected.

Acknowledge trigger bit (W)

ACKT	When set after transfer, $\overline{\text{ACK}}$ is output in phase with the next $\overline{\text{SCK0}}$. After $\overline{\text{ACK}}$ signal output, this bit is automatically cleared to 0.
------	---

- Cautions**
1. Never set ACKT before or during serial transfer.
 2. ACKT cannot be cleared by software.
 3. Before setting ACKT, set ACKE = 0.

Acknowledge enable bit (R/W)

ACKE	0	Disables automatic output of the acknowledge signal ($\overline{\text{ACK}}$). (Output by ACKT is possible.)	
	1	When set before transfer	$\overline{\text{ACK}}$ is output in phase with the 9th clock of $\overline{\text{SCK0}}$.
		When set after transfer	$\overline{\text{ACK}}$ is output in phase with $\overline{\text{SCK0}}$ immediately following the set instruction execution.

Acknowledge detection flag (R)

ACKD	Condition for being cleared (ACKD = 0)	Condition for being set (ACKD = 1)
	<p><1> The transfer operation is started.</p> <p><2> The $\overline{\text{RESET}}$ signal is entered.</p>	The acknowledge signal ($\overline{\text{ACK}}$) is detected (in phase with the rising edge of SCK0).

Busy enable bit (R/W)

BSYE	0	<p><1> The busy signal is automatically disabled.</p> <p><2> Busy signal output is stopped in phase with the falling edge of $\overline{SCK0}$ immediately after clear instruction execution.</p>
	1	The busy signal is output after the acknowledge signal in phase with the falling edge of $\overline{SCK0}$.

(4) Serial clock selection

To select the serial clock, manipulate bits 0 and 1 of serial operation mode register 0 (CSIM0). The serial clock can be selected out of the following four clocks:

Table 5-13. Serial Clock Selection and Application (In the SBI Mode)

Mode register		Serial clock		Timing for shift register R/W and start of serial transfer	Application
CSIM0	CSIM0	Source	Masking of serial clock		
1	0				
0	0	External $\overline{SCK0}$	Automatically masked when 8-bit data transfer is completed	<p><1> In the operation halt mode (CSIE0 = 0)</p> <p><2> When the serial clock is masked after 8-bit transfer</p> <p><3> When $\overline{SCK0}$ is high</p>	Slave CPU
0	1	TOUT flip-flop			Arbitrary-speed serial transfer
1	0	$f_x/2^4$			Middle-speed serial transfer
1	1	$f_x/2^3$			High-speed serial transfer

When the internal system clock is selected, $\overline{SCK0}$ is internally terminated when the 8th clock has been output, and is externally counted until the slave enters the ready state.

(5) Signals

Figures 5-61 to 5-66 show signals to be generated in the SBI mode and flag operations on the SBIC. Table 5-14 lists signals used in the SBI mode.

Figure 5-61. Operations of RELT, CMDT, RELD, and CMDD (Master)

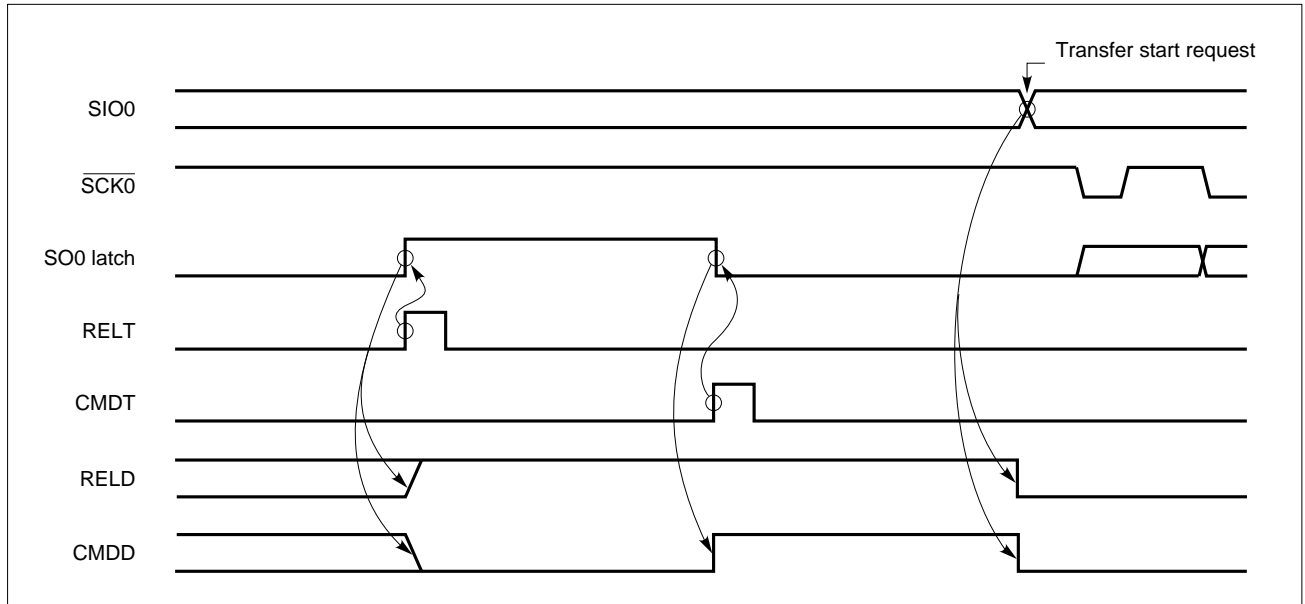

Figure 5-62. Operations of RELT, CMDT, RELD, and CMDD (Slave)

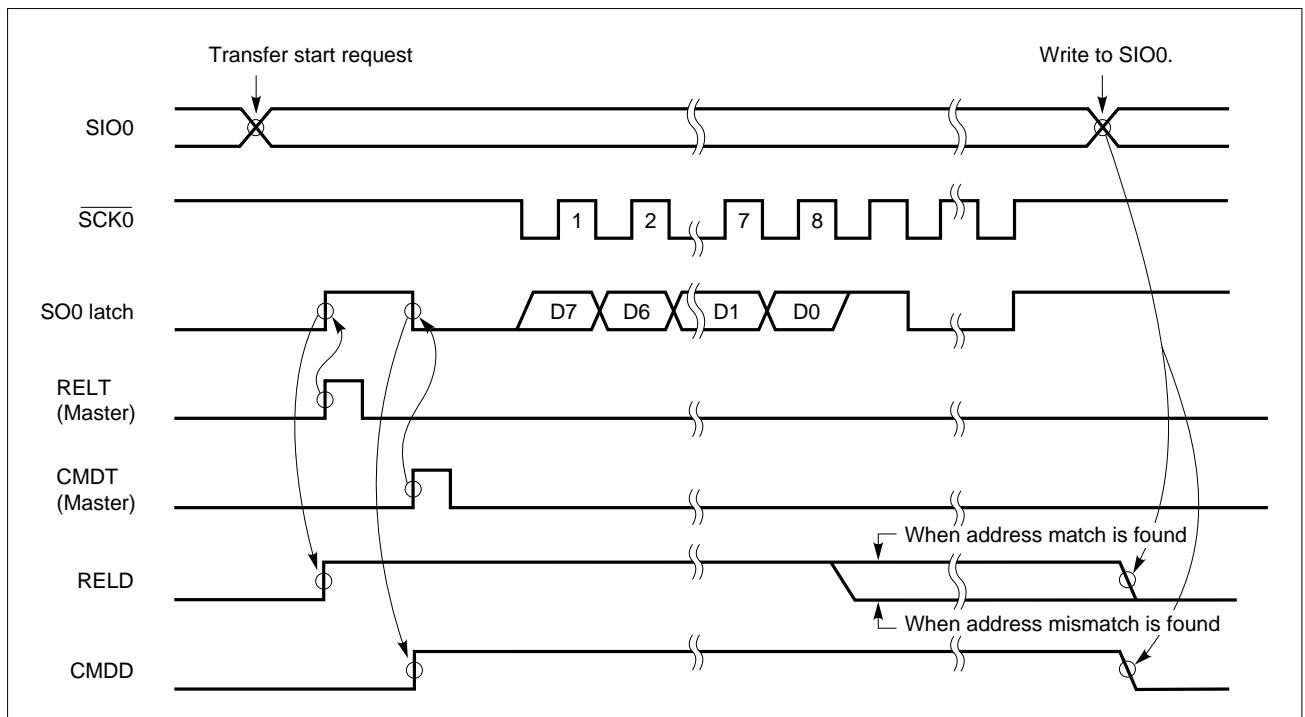
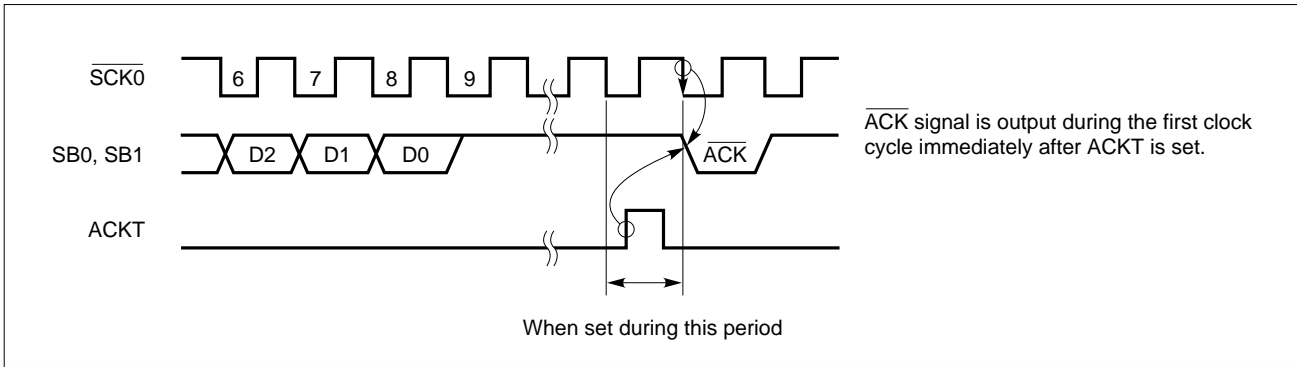

Figure 5-63. Operation of ACKT



Caution Do not set the ACKT until the transfer is completed.

Figure 5-64. Operation of ACKE

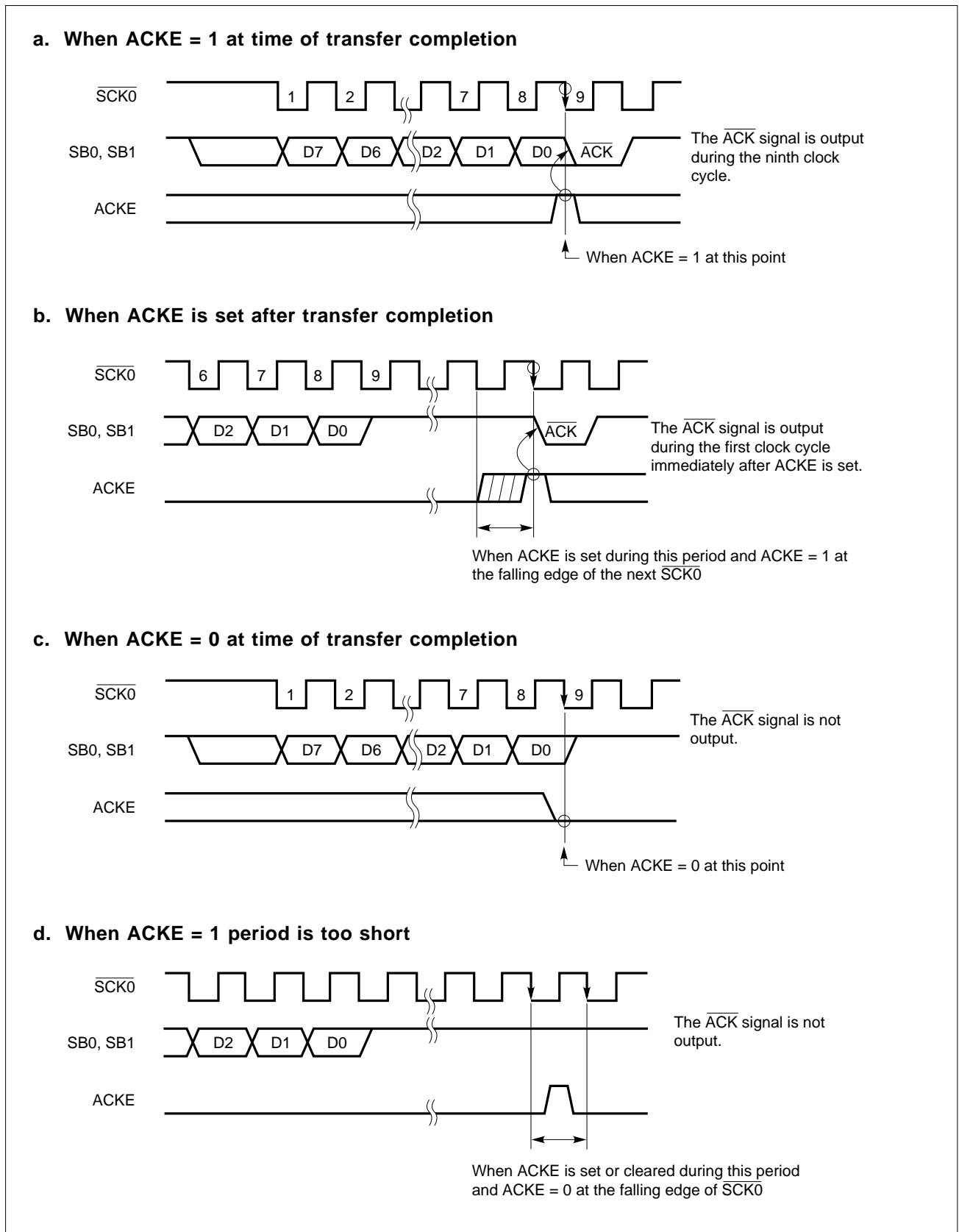

Figure 5-65. Operation of ACKD

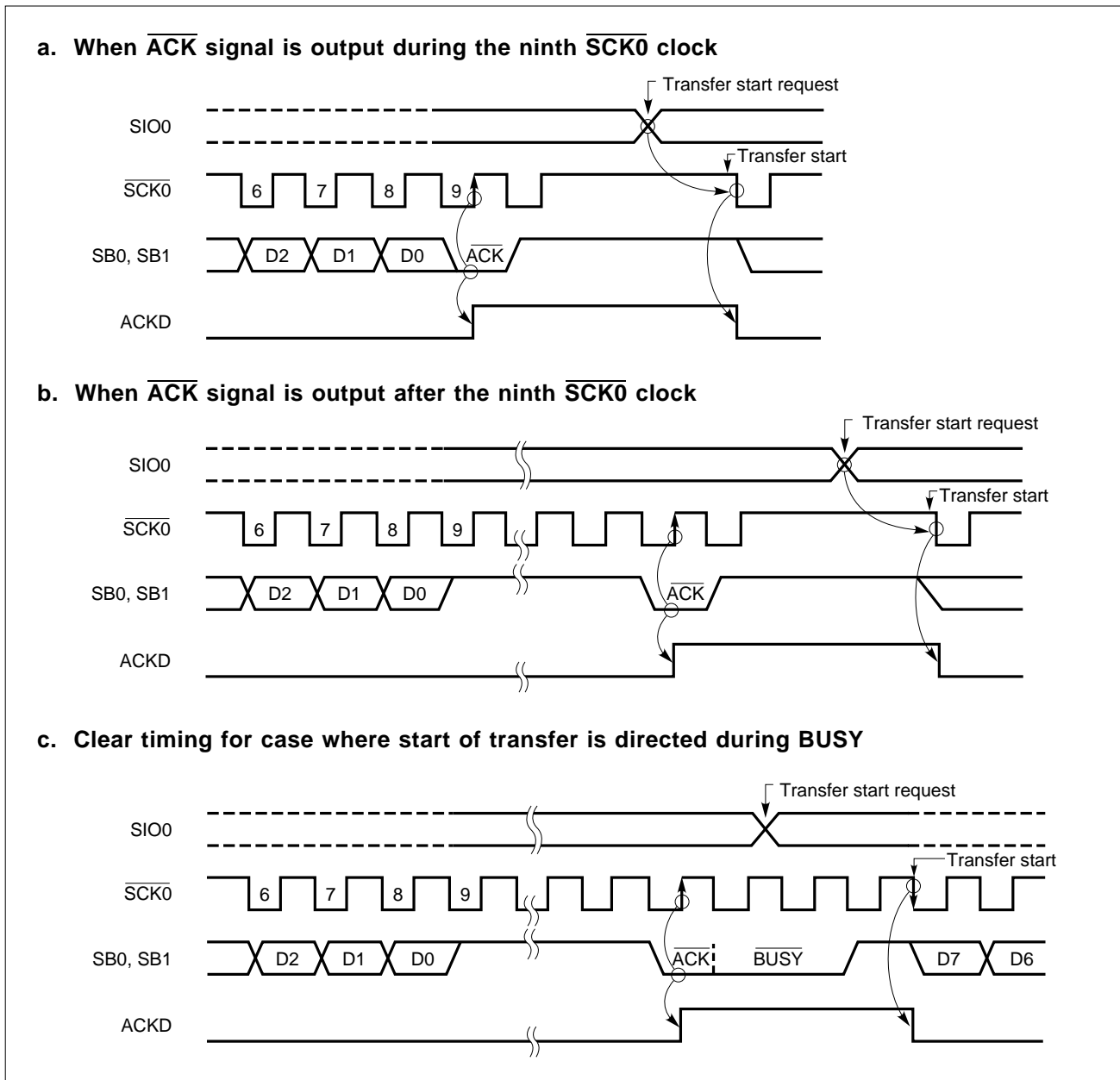
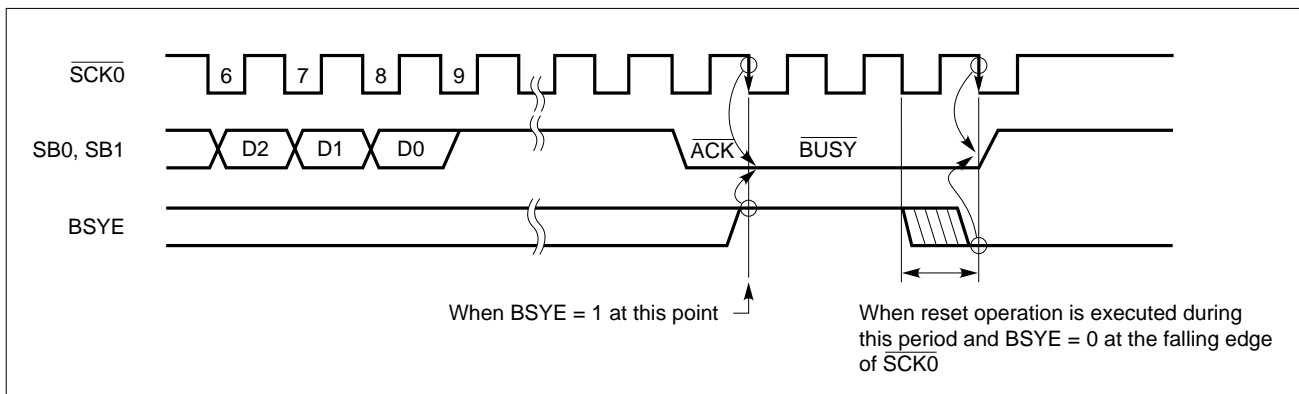

Figure 5-66. Operation of BSYE



Signal name	Output device	Definition	Timing chart	Condition for output	Flag operation	Meaning of signal
Bus release signal (REL)	Master	Rising edge of SB0 or SB1 when SCK0 = 1		<ul style="list-style-type: none"> • RELT is set. 	<ul style="list-style-type: none"> • RELD is set. • CMDD is cleared. 	Indicates that CMD signal follows and data transmitted is address data.
Command signal (CMD)	Master	Falling edge of SB0 or SB1 when SCK0 = 1		<ul style="list-style-type: none"> • CMDT is set. 	<ul style="list-style-type: none"> • CMDD is set. 	i) Data transmitted after REL signal output is address. ii) Data transmitted, with REL signal not being output, is command.
Acknowledge signal (ACK)	Master/slave	Low level signal output on SB0 or SB1 during one SCK0 clock cycle after serial reception is completed	[Synchronous $\overline{\text{BUSY}}$ output] 	<1> ACKE = 1 <2> ACKT is set.	<ul style="list-style-type: none"> • ACKD is set. 	Indicates completion of reception.
Busy signal (BUSY)	Slave	[Synchronous $\overline{\text{BUSY}}$ signal] Low level signal output on SB0 or SB1 after acknowledge signal		<ul style="list-style-type: none"> • BSYE = 1 	-	Indicates that serial reception is disabled because processing is in progress.
Ready signal (READY)	Slave	High level signal output on SB0 or SB1 before serial transfer is started or after serial transfer is completed		<1> BSYE = 0 <2> Execution of instruction to write data to SIO0 (Transfer start request)	-	Indicates that serial reception is enabled.

Table 5-14. Various Signals Used in the SBI Mode (1/2)

Table 5-14. Various Signals Used in the SBI Mode (2/2)

Signal name	Output device	Definition	Timing chart	Condition for output	Flag operation	Meaning of signal
Serial clock (SCK0)	Master	Synchronous clock for outputting address/command/data, $\overline{\text{ACK}}$ signal, synchronous BUSY signal, and so on. Address/command/data is output during first 8 clock cycles.		Execution of instruction to write data to SIO0 when CSIE = 1 (Serial transfer start request) ^(Note 2)	IRQCSI0 is set (on rising edge of 9th clock of $\overline{\text{SCK0}}$) ^(Note 1)	Timing of signal output on serial data bus
Address (A7 - A0)	Master	8-bit data transferred in phase with SCK0 after REL signal and CMD signal output				Address of slave device on serial bus
Command (C7 - C0)	Master	8-bit data transferred in phase with SCK0 after only CMD signal is output, with REL signal not being output				Directions and messages to slave device
Data (D7 - D0)	Master/slave	8-bit data transferred in phase with $\overline{\text{SCK0}}$, with neither REL signal nor CMD signal being output				Numeric processed by slave or master device

(Note 1)

When WUP = 0, IRQCSI0 is always set on the ninth rising edge of the SCK0 signal.

When WUP = 1, IRQCSI0 is set only when the received address matches the value held in the slave address register (SVA).

(Note 2)

In the $\overline{\text{BUSY}}$ state, data transfer is initiated after the READY state is set.

Phase-out/Discontinued

(6) Pin configuration

The configurations of serial clock pin $\overline{SCK0}$ and serial data bus pin SB0 or SB1 are as follows:

(a) $\overline{SCK0}$: Pin for serial clock I/O

<1> Master : CMOS, push-pull output

<2> Slave : Schmitt input

(b) SB0, SB1: Pin for serial data I/O

Output to SB0 or SB1 is an N-ch open-drain output and input is Schmitt input for both the master and a slave.

The serial data bus line must be externally pulled up because it has originally an N-ch open-drain output.

Figure 5-67. Pin Configuration

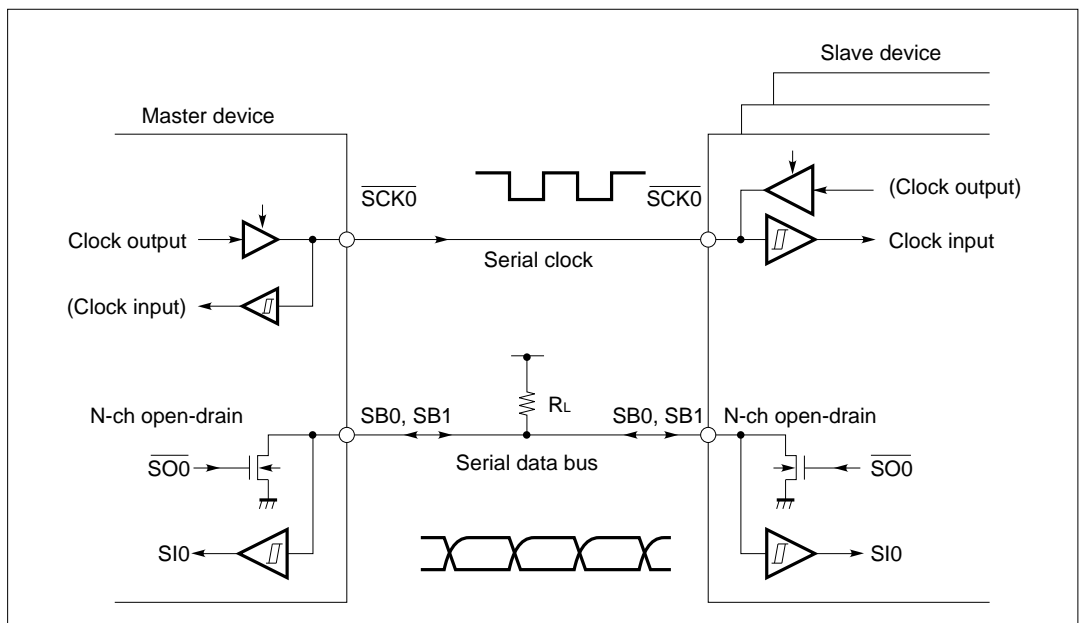

Caution When data is received, the N-ch transistor must be turned off, so FFH must be written to SIO0 beforehand. The N-ch open-drain output can be turned off at any time during transfer. However, when the wake-up function specification bit (WUP) is set to 1, the N-ch transistor is always off, so there is no need to write FFH to SIO0 before reception.

(7) Address match detection method

In the SBI mode, communication starts when the master selects a particular slave device by outputting an address.

An address match is detected by hardware. The slave address register (SVA) is available. In the wake-up state (WUP = 1), IRQCSI0 is set only when the address transmitted by the master and the value held in SVA match.

Cautions 1. Whether a slave is selected is determined by detecting a match for a slave address received after bus release (in the state of RELD = 1).

An address match is detected usually using an address match interrupt (IRQCSI0) generated when WUP is set to 1. So detect selection/nonselection state by slave address when WUP is set to 1.

- 2. When determining whether a slave is selected without using an interrupt when WUP is 0, do not use the address match detection method. Instead, use transfer of commands set in advance in a program.**
-

(8) Error detection

In the SBI mode, the state of serial bus SB0 or SB1 being used for communication is loaded into the shift register (SIO0) of the transmitting device. So a transmission error can be detected by the methods described below.

(a) Comparing SIO0 data before start of transmission with SIO0 data after start of transmission

With this method, the occurrence of a transmission error is assumed if two SIO0 values disagree with each other.

(b) Using the slave address register (SVA)

Transmit data is set in SIO0 and SVA as well before the data is transmitted. On completion of transmission, the COI bit (match signal from the address comparator) of serial operation mode register 0 (CSIM0) is tested. If the result is 1, the transmission is regarded as successful. If the result is 0, the occurrence of a transmission error is assumed.

(9) Communication operation

In the SBI mode, the master usually selects a slave device to communicate with from multiple devices by outputting the address of the slave to the serial bus.

After selecting a device to communicate with, the master exchanges commands and data with the slave device, thus establishing serial communication.

Figures 5-68 to 5-71 show the timing charts of data communication operations.

In the SBI mode, the shift register performs shift operation on the falling edge of the serial clock ($\overline{SCK0}$). Transmit data is held on the SO0 latch, and is output on the SB0/P02 or SB1/P03 pin starting with the MSB. Receive data applied to the SB0 (or SB1) pin is latched in the shift register on the rising edge of $\overline{SCK0}$.

Figure 5-68. Address Transfer Operation from Master Device to Slave Device (WUP = 1)

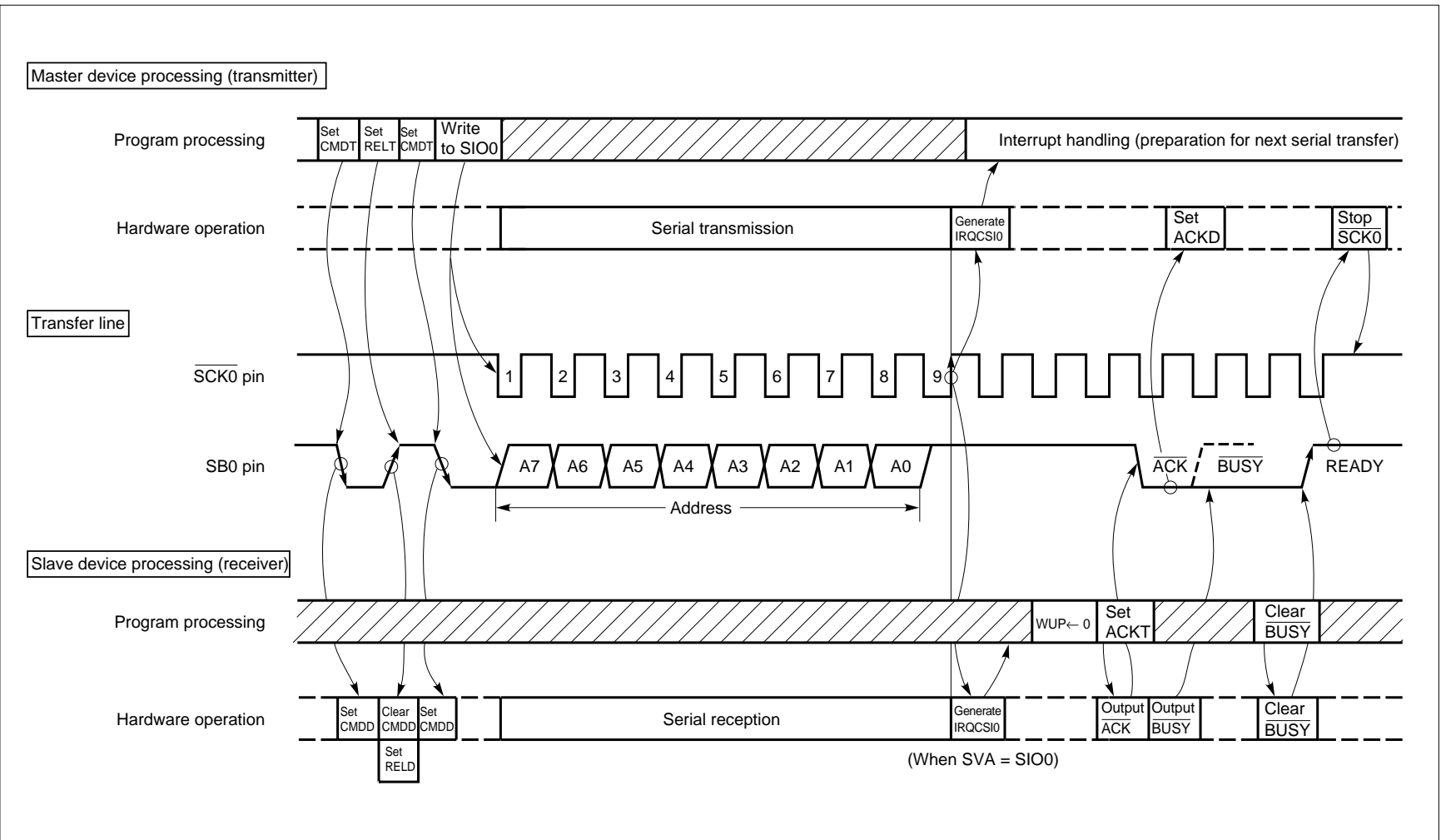
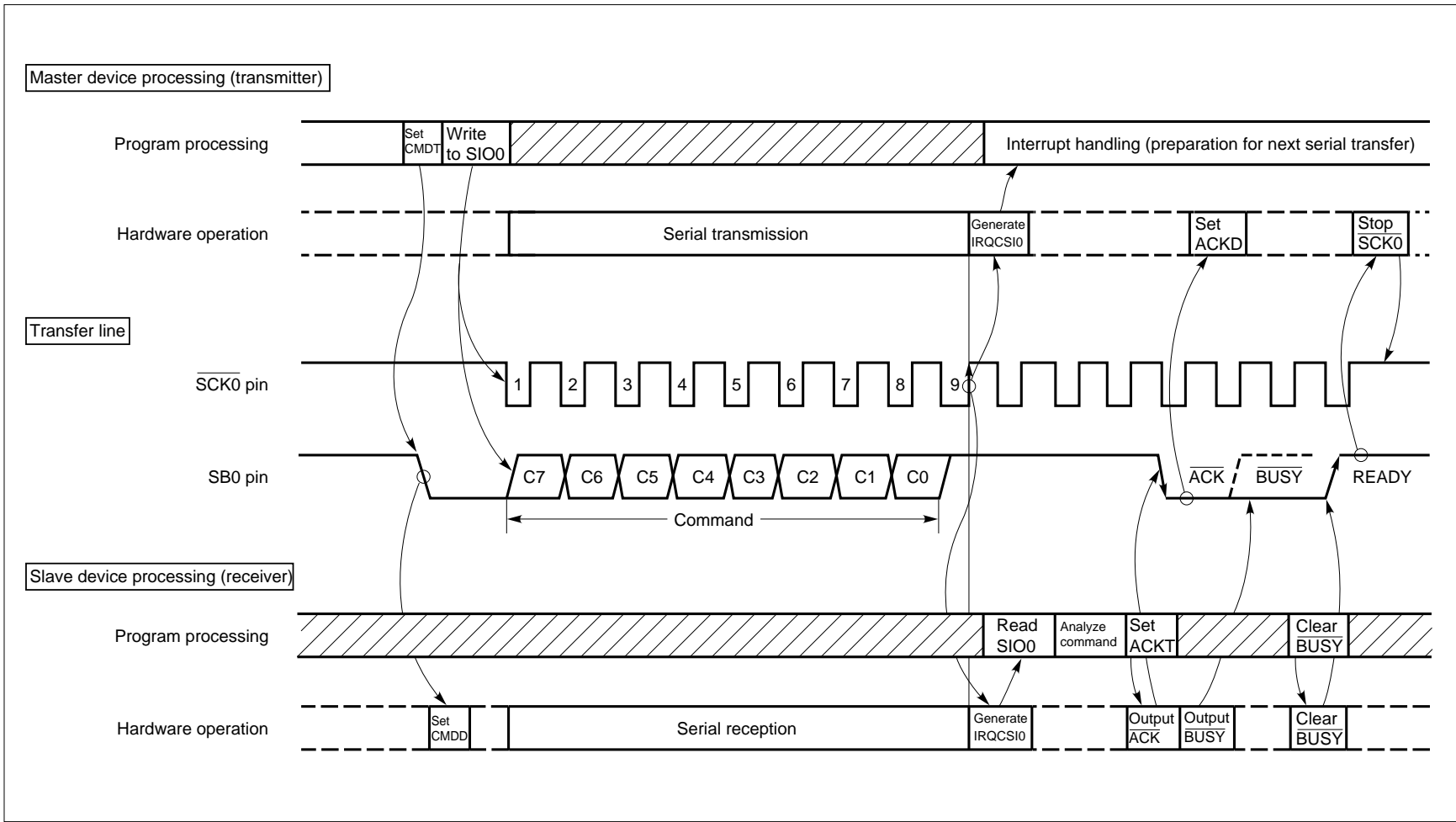

Figure 5-69. Command Transfer Operation from Master Device to Slave Device



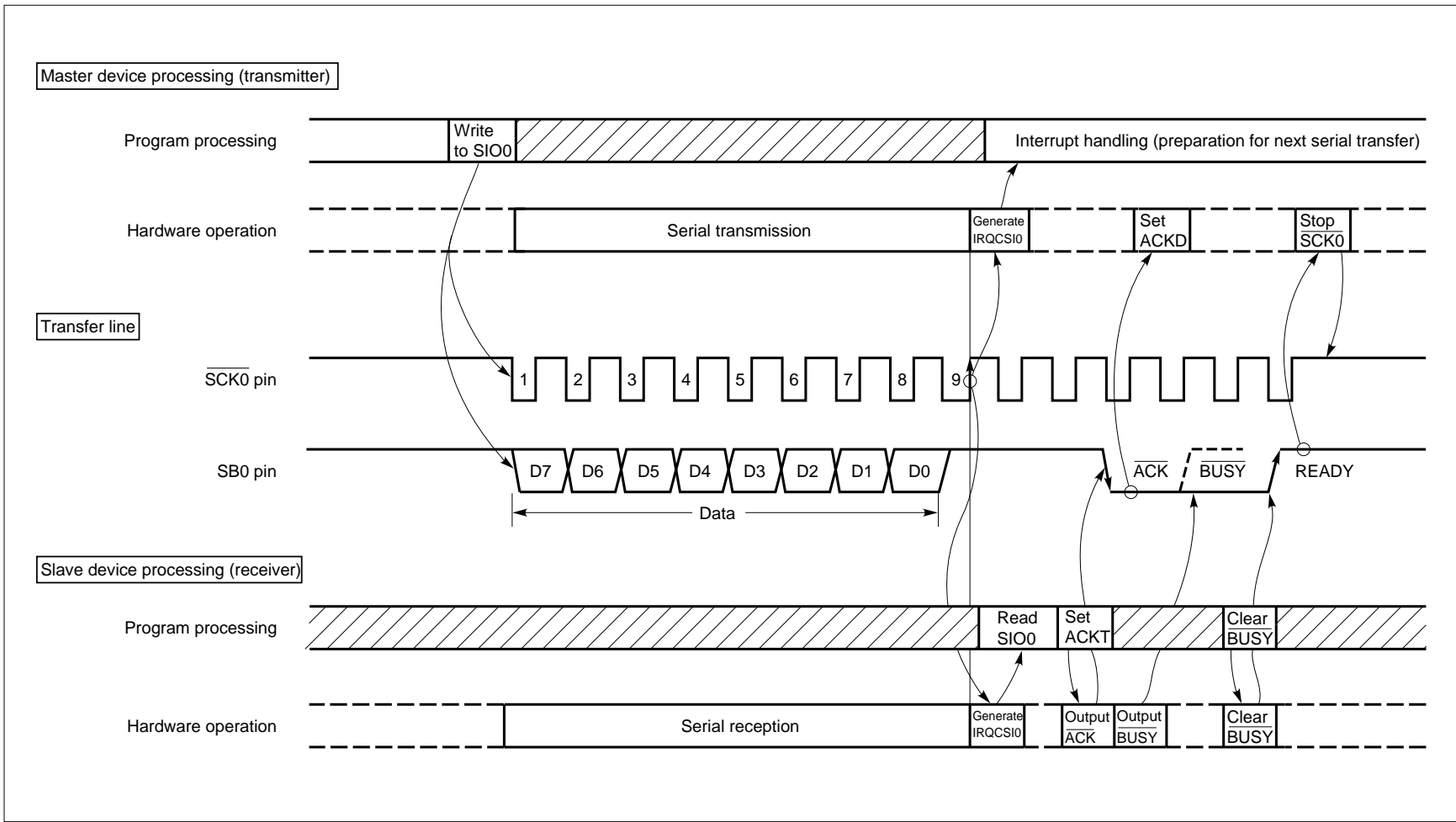
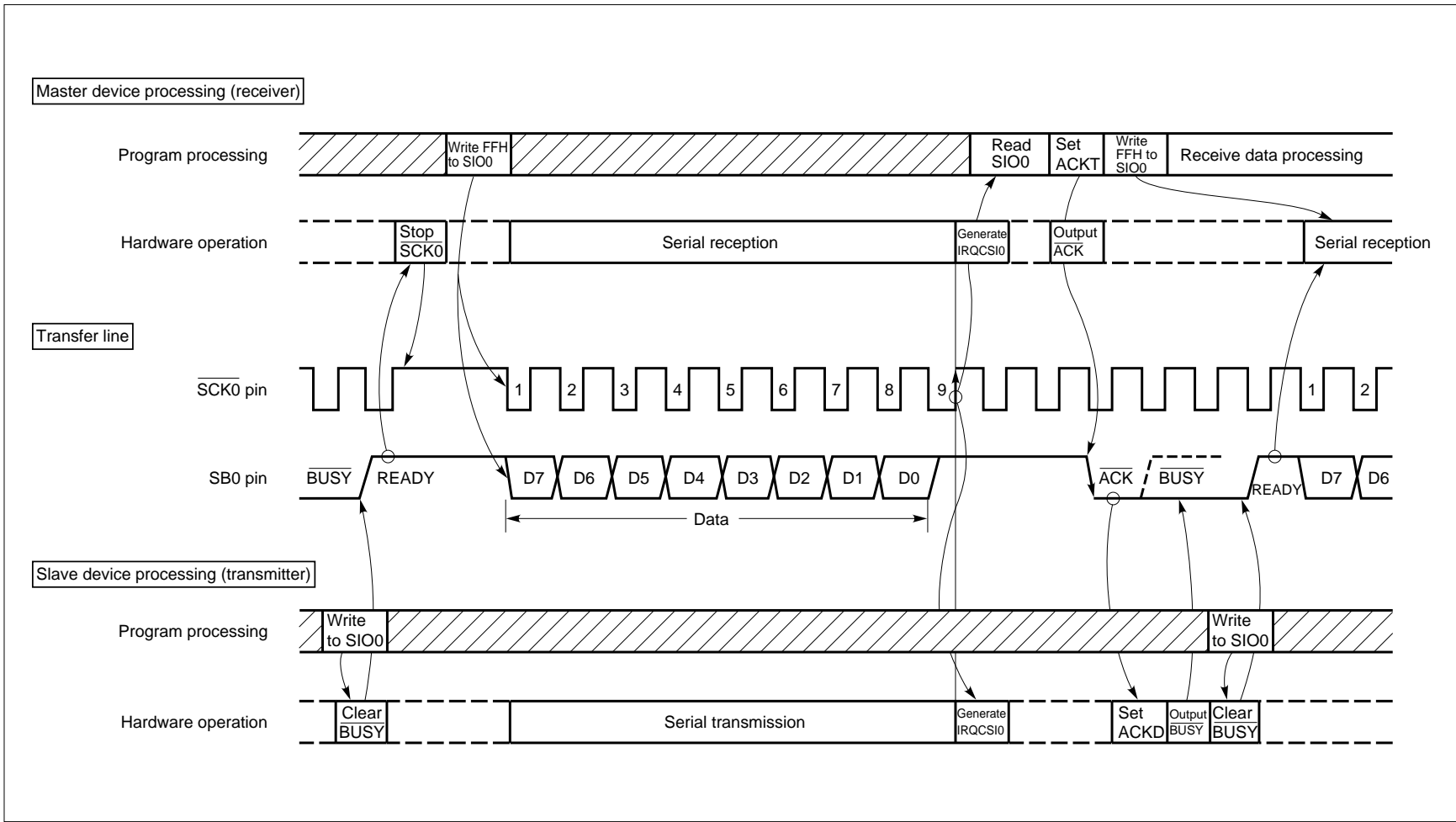

Figure 5-70. Data Transfer Operation from Master Device to Slave Device

Figure 5-71. Data Transfer Operation from Slave Device to Master Device



(10) Transfer start

Serial transfer is started by writing transfer data in shift register 0 (SIO0), provided that the following two conditions are satisfied:

- The serial interface operation enable/disable bit (CSIE0) is set to 1.
- The internal serial clock is not operating after 8-bit serial transfer, or $\overline{\text{SCK0}}$ is high.

Cautions 1. Transfer cannot be started by setting CSIE0 to 1 after writing data to the shift register.

- 2. The N-ch transistor needs to be turned off when data is received. So FFH must be written to SIO0 beforehand.**

However, when the wake-up function specification bit (WUP) is set to 1, the N-ch transistor is always off. So FFH need not be written to SIO0 beforehand for reception.

- 3. If data is written to SIO0 when the slave is busy, the data is not lost.**

Transfer is started when the busy state is released and input to SB0 (or SB1) goes high.

When eight bits have been transferred, serial transfer automatically terminates setting the interrupt request flag (IRQCSI0).

Example When RAM data specified by the HL register is transferred to SIO0, from which data is loaded into the accumulator at the same time, and serial transfer is started.

```
MOV  XA,@HL ; Extracts transmit data from RAM
```

```
SEL  MB15    ; or CLR1 MBE
```

```
XCH  XA,SIO0 ; Exchanges transmit data with receive data and starts transfer
```

(11) Notes on the SBI mode

- (a) Whether a slave is selected is determined by detecting a match for a slave address received after bus release (in the state of $RELD = 1$).
An address match is detected usually using, an address match interrupt (IRQCSI0) generated when WUP is 1. So detect selection/nonselection state by slave address when WUP is set to 1.
- (b) When determining whether a slave is selected without using an interrupt when $WUP = 0$, do not use the address match detection method. Instead, use transfer of commands set in advance in a program.
- (c) When WUP is set to 1 during \overline{BUSY} signal output, \overline{BUSY} is not released. In the SBI mode, after release of \overline{BUSY} is directed, the \overline{BUSY} signal is output until the next falling edge of the serial clock ($\overline{SCK0}$) appears. Before setting WUP to 1, be sure to confirm that the SB0 or SB1 pin is high after releasing \overline{BUSY} .

(12) SBI mode

This section describes an example of application which performs serial data communication in the SBI mode. In the example, the μ PD75518 can be used as either the master CPU or a slave CPU on the serial bus.

The master can be switched to another CPU with a command.

(a) Serial bus configuration

In the serial bus configuration used for the example of this section, a μ PD75518 is connected to the bus line as a device on the serial bus.

Two pins on the μ PD75518 are used: serial data bus SB0 (S02/SO0) and serial clock $\overline{\text{SCK0}}$ (P01).

Figure 5-72 shows an example of the serial bus configuration.

Figure 5-72. Example of Serial Bus Configuration

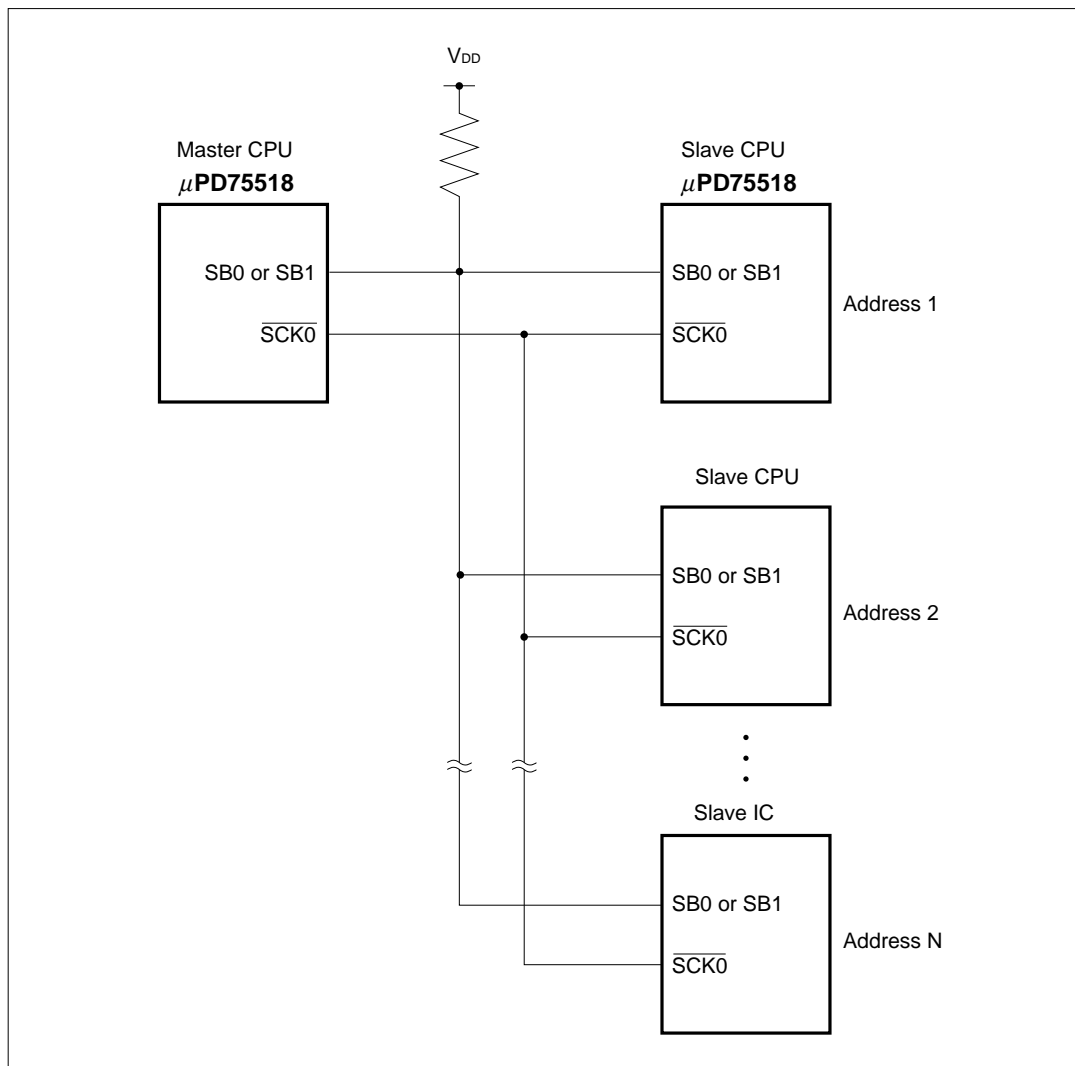

(b) Explanation of commands**<Types of commands>**

This example uses the following commands:

- <1> READ command : Transfers data from slave to master.
- <2> WRITE command : Transfers data from master to slave.
- <3> END command : Informs slave of WRITE command completion.
- <4> STOP command : Informs slave of WRITE command interruption.
- <5> STATUS command : Reads slave status.
- <6> RESET command : Sets currently selected slave as non-selected slave.
- <7> CHGMST command : Passes master authority to slave.

<Protocol>

The following protocol is used for communication between the master and slaves.

- <1> The address of a slave with which the master intends to communicate is transmitted to select the slave (chip select). This starts communication.

The slave that has received the address returns \overline{ACK} to engage in communication with the master. (The state of the slave is changed from the non-selected state to selected state.)

- <2> Commands and data are transferred between the master and the slave selected in <1>.

Command and data are transferred between the master and the selected slave on a one-to-one basis, so the other slaves must be placed in the non-selected state.

- <3> Communication is completed when the selected slave is placed in the non-selected state. This state is caused in the following cases:
 - The selected slave is placed in the non-selected state when the slave receives a RESET command from the master.
 - The device that is switched from the master to a slave with a CHGMST command is placed in the non-selected state.

<Command format>

The transfer format of each command is described below.

<1> READ command

The READ command reads data from a slave. One to 256 bytes of data can be read. The data length is specified in a parameter by the master. When 00H is specified as the data length, the 256-byte data transfer is assumed.

Figure 5-73. Transfer Format of the READ Command

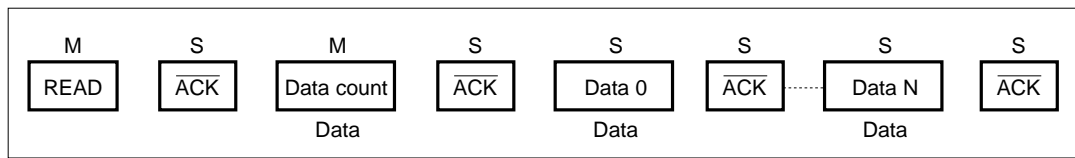

Remarks M: Output by the master
S: Output by the slave

When the slave receives a transmission data count, if it has data enough for transmitting the specified number of bytes of data, the slave returns $\overline{\text{ACK}}$. If the slave does not have enough data for transmission, an error occurs; $\overline{\text{ACK}}$ is not returned in this case.

The master sends $\overline{\text{ACK}}$ to the slave each time it receives one byte.

<2> WRITE command, END command, STOP command

These commands write data to a slave. One to 256 bytes of data can be written. The data length is specified in a parameter by the master. When 00H is specified as the data length, the 256-byte data transfer is assumed.

Figure 5-74. Transfer Format of the WRITE and END Commands

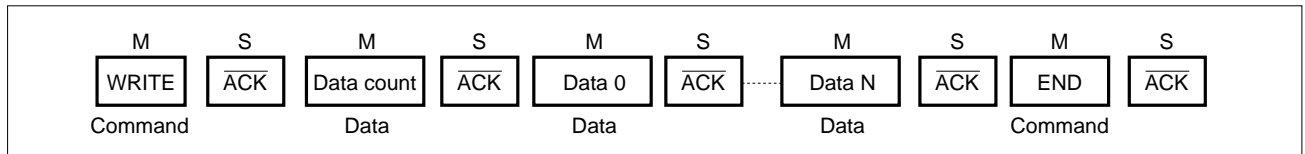

Remarks M: Output by the master
S: Output by the slave

If the slave has an enough area for storing receive data of the specified length, the slave returns $\overline{\text{ACK}}$. If the slave does not have an enough area, an error occurs; $\overline{\text{ACK}}$ is not returned in this case.

The master transmits an END command when all data have been transferred. The END command informs the slave that all data have been transferred correctly.

The slave accepts an END command even before data reception is uncompleted. In this case, the data received just before the acceptance of the END command becomes valid.

The master compares the contents of SIO0 before transfer with the contents of SIO0 after transfer to check whether the data has been output onto the bus correctly. If the contents of SIO0 disagree with each other, the master interrupts data transfer by transmitting a STOP command.

Figure 5-75. Transfer Format of the STOP Command

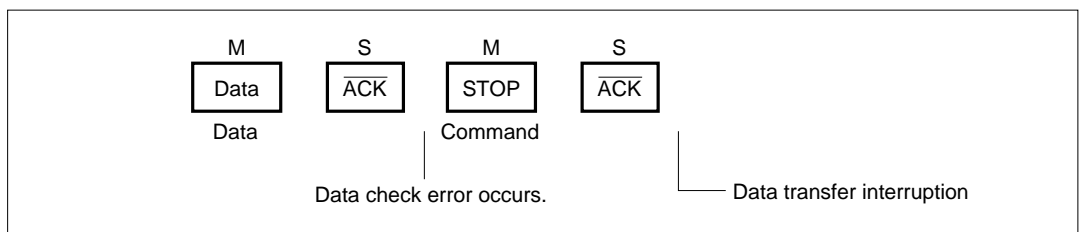

Remarks M: Output by the master
S: Output by the slave

When the slave receives a STOP command, the slave invalidates the most recently received one byte.

<3> STATUS command

The STATUS command reads the status of the current slave.

Figure 5-76. Transfer Format of the STATUS Command

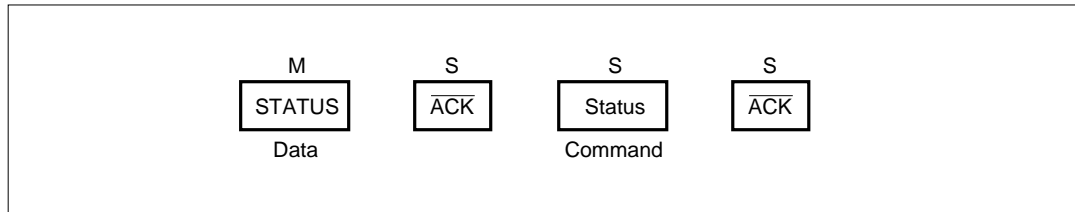

Remarks M: Output by the master
S: Output by the slave

The slave returns the status in the format shown in Figure 5-77.

Figure 5-77. Status Format of the STATUS Command

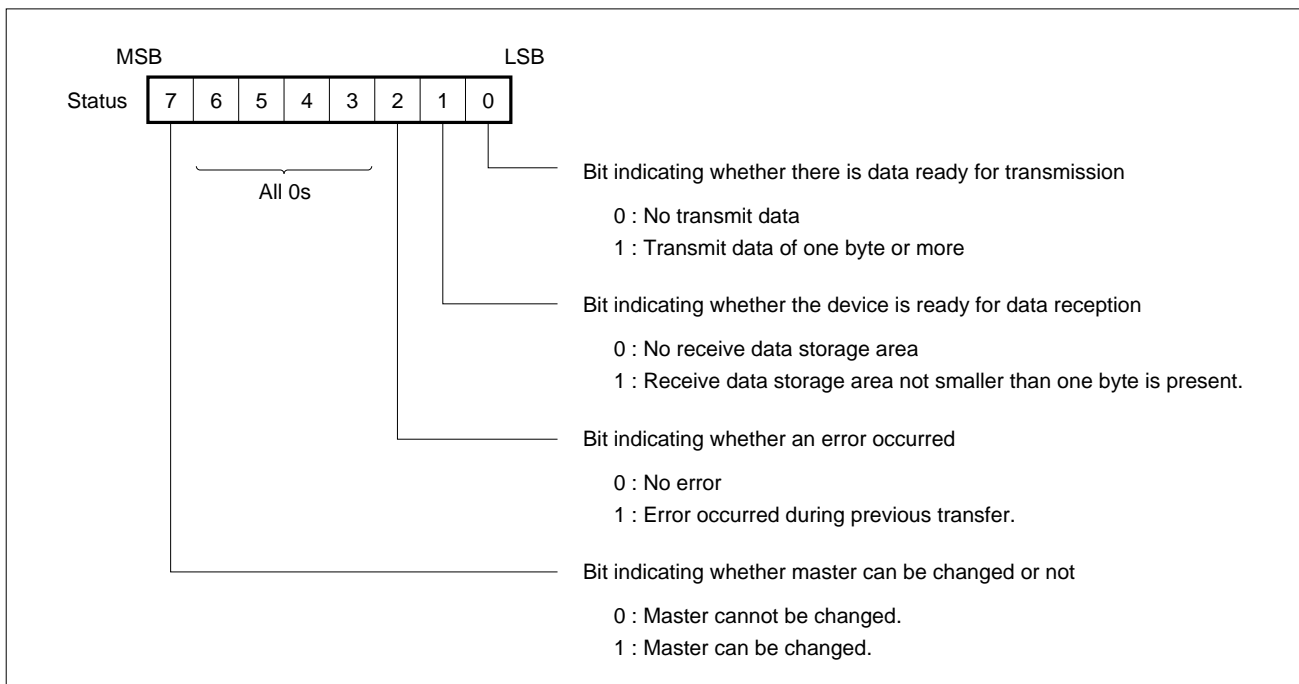

When the master receives a status, it returns $\overline{\text{ACK}}$ to the current slave.

<4> RESET command

The RESET command changes the currently selected slave to a non-selected slave. When a RESET command is transmitted, any slave can be placed in the non-selected state.

Figure 5-78. Transfer Format of the RESET Command

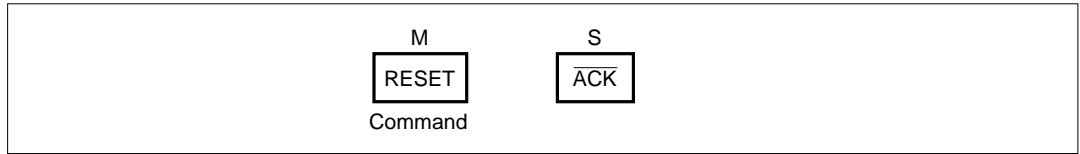

Remarks M: Output by the master
S: Output by the slave

<5> CHGMST command

The CHGMST command passes the master authority to the currently selected slave.

Figure 5-79. Transfer Format of the CHGMST Command

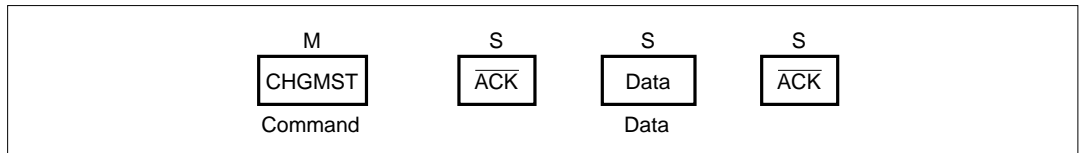

Remarks M: Output by the master
S: Output by the slave

When the slave receives a CHGMST command, the slave returns one of the following data to the master after checking whether the slave can receive the master authority:

- 0FFH : Master changeable
- 00H : Master not changeable

The slave compares the contents of SIO0 before transfer with the contents of SIO0 after transfer. If the contents of SIO0 disagree with each other, an error occurs; $\overline{\text{ACK}}$ is not returned in this case.

If the master receives 0FFH, the master returns $\overline{\text{ACK}}$ to the slave, and starts to operate as a slave. The slave which transmitted 0FFH starts to operate as the master when it receives $\overline{\text{ACK}}$.

<Error occurrence>

If a communication error occurs, the operation described below is performed.

The slave reports the occurrence of an error by not returning $\overline{\text{ACK}}$ to the master. If an error occurs during reception of data, the slave sets the status bit for indicating error occurrence, and cancels all command processing being performed.

When the transmission of one byte is completed, the master checks for $\overline{\text{ACK}}$ from the slave. If $\overline{\text{ACK}}$ is not returned from the slave within a predetermined period after transmission completion, the occurrence of an error is assumed; the master outputs the $\overline{\text{ACK}}$ signal as a dummy.

Figure 5-80. Master and Slave Operation in Case of Error

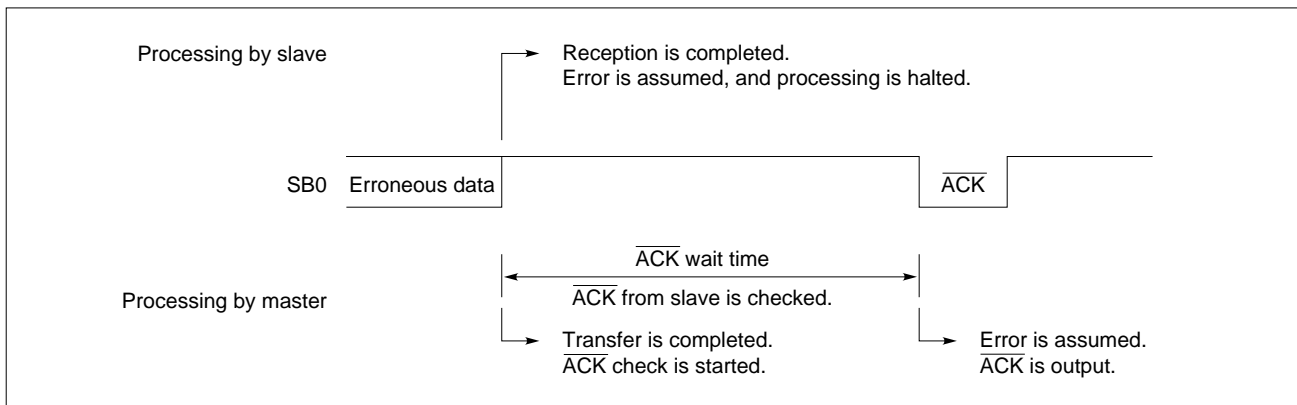

The following errors may occur:

- Error that may occur on the slave side
 - <1> Invalid command transfer format
 - <2> Reception of an undefined command
 - <3> Insufficient number of transfer data bytes for a READ command
 - <4> Insufficient area to contain data for a WRITE command
 - <5> Change in data during transmission of a READ, STATUS, or CHGMST command

If any of the above types of errors occurs, $\overline{\text{ACK}}$ is not returned.

- Error that may occur on the master side

If data transmitted with a WRITE command changes during transmission, the master transmits a STOP command to the slave.

5.7.8 Manipulation of $\overline{SCK0}$ Pin Output

The $\overline{SCK0}/P01$ pin has a built-in output latch, so that this pin allows static output by software manipulation in addition to normal serial clock output.

The number of $\overline{SCK0}$ pulses can be software-set arbitrarily by manipulating the P01 output latch. (The $SO0/SB0/SB1$ pin is controlled by manipulating the RELT and CMDT bits of SBIC.)

The procedure for manipulating $\overline{SCK0}/P01$ pin output is explained below.

<1> Set serial operation mode register 0 (CSIM0) ($\overline{SCK0}$ pin: output mode. When serial transfer is halted, $\overline{SCK0} = 1$).

<2> Manipulate the P01 output latch by using a bit manipulation instruction.

Example To output one $\overline{SCK0}$ clock cycle by software

```

SEL    MB15          ; or CLR1  MBE
MOV    XA,#00000011B ;  $\overline{SCK0}$  ( $f_X/2^3$ ), output mode
MOV    CSIM0,XA
CLR1   0FF0H.1      ;  $\overline{SCK0}/P01 <- 0$ 
SET1   0FF0H.1      ;  $\overline{SCK0}/P01 <- 1$ 
    
```

Figure 5-81. $\overline{SCK0}/P01$ Pin Circuit Configuration

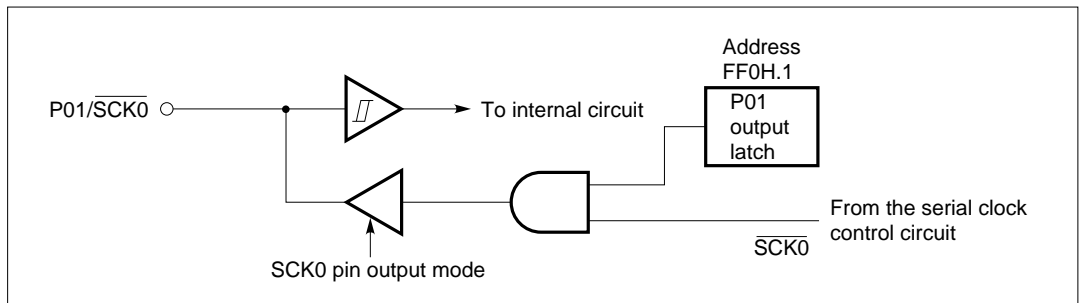

The P01 output latch is mapped to bit 1 of address FF0H. A \overline{RESET} signal sets the P01 output latch to 1.

-
- Cautions**
1. During normal serial transfer, the P01 output latch must be set to 1.
 2. The P01 output latch cannot be addressed by specifying PORT0.1 (as described below). The address of the latch (FF0H.1) must be coded in the operand of an instruction directly. However, MBE = 0 (or MBE = 1, MBS = 15) must be specified before the instruction is executed.

CLR1	PORT0.1	<input type="checkbox"/>	Not allowed
SET1	PORT0.1	<input type="checkbox"/>	
CLR1	0FF0H.1	<input type="checkbox"/>	Allowed
SET1	0FF0H.1	<input type="checkbox"/>	

5.8 Serial Interface (Channel 1)

5.8.1 Serial Interface (Channel 1) Functions

The μ PD75518 has two modes. The functions of the two modes are outlined below.

(1) Operation halt mode

This mode is used when serial transfer is not performed. This mode reduces power consumption.

(2) Three-wire serial I/O mode

8-bit data transfer is performed using three lines: Serial clock ($\overline{\text{SCK1}}$), serial output (SO1), and serial input (SI1).

The three-wire serial I/O mode allows full-duplex transmission, so data transfer can be performed at higher speed.

8-bit serial transfer always starts with the MSB.

The three-wire serial I/O mode enables connections to be made with the 75X series, 78K series, and many other types of peripheral I/O devices.

5.8.2 Serial Interface (Channel 1) Configuration

Figure 5-82 shows the block diagram of the serial interface (channel 1).

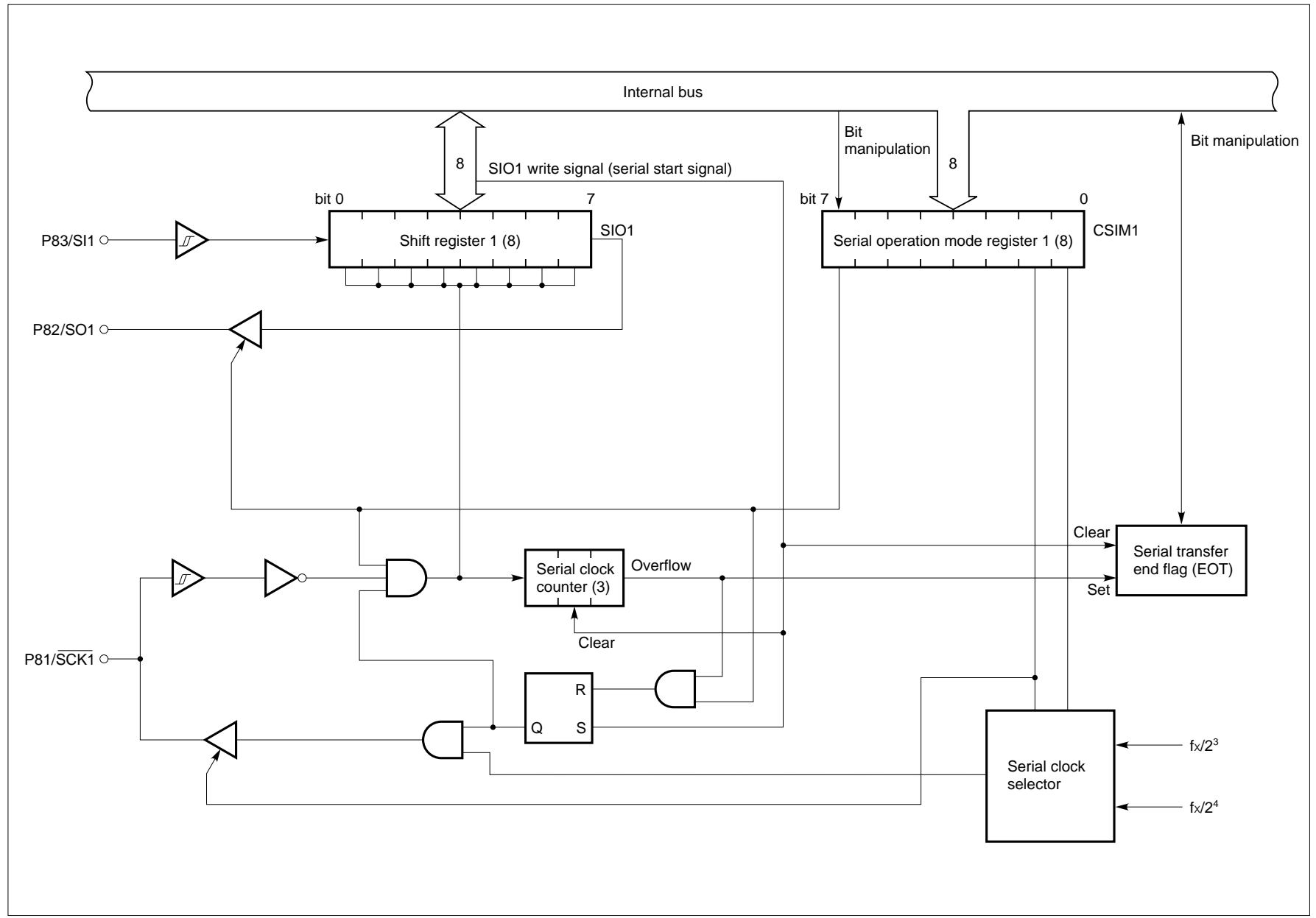

Figure 5-82. Block Diagram of the Serial Interface (Channel 1)

5.8.3 Register Functions

(1) Serial operation mode register 1 (CSIM1)

Figure 5-83 shows the format of serial operation mode register 1 (CSIM1).

CSIM1 is an 8-bit register which specifies a serial interface (channel 1) operation mode and serial clock.

CSIM1 is manipulated using an 8-bit memory manipulation instruction. Only the high-order one bit can be manipulated independently. Each bit can be manipulated using its name.

The $\overline{\text{RESET}}$ signal resets this register to 00H.

Figure 5-83. Format of Serial Operation Mode Register 1 (CSIM1)

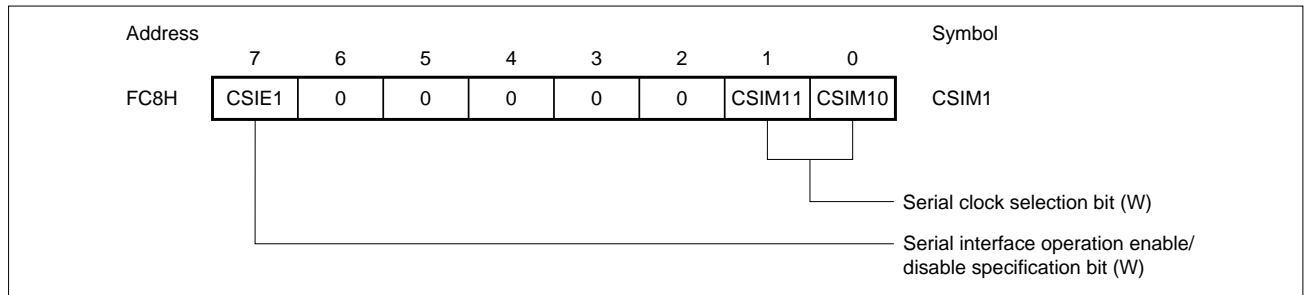

Remark (W): Write only

Serial clock selection bit (W)

CSIM11	CSIM10	Serial clock (three-wire serial I/O mode)	$\overline{\text{SCK1}}$ pin mode
0	0	External clock applied to $\overline{\text{SCK1}}$ pin	Input
0	1	Not to be set	—
1	0	$f_x/2^4$ (262 kHz or 375 kHz)(Note)	Output
1	1	$f_x/2^3$ (524 kHz or 750 kHz)(Note)	

(Note) The values at 4.19 MHz and 6.0 MHz are indicated in parentheses.

Serial interface operation enable/disable specification bit (W)

		Shift register operation	Serial clock counter	EOT flag	SO1 and SI1 pins
CSIE1	0	Shift operation disabled	Cleared	Held	Used only for port 8
	1	Shift operation enabled	Count operation	Can be set	Used in each mode as well as for port 8

Caution Be sure to write 0 to bits 2 to 6 of the serial operation mode register.

Example To select $f_X/2^4$ as the serial clock, and to set the serial transfer end flag EOT to 1 each time serial transfer terminates

```
SEL MB15          ; or CLR1 MBE
MOV XA,#10000010B
MOV CSIM1,XA      ; CSIM1 <- 10000010B
```

(2) Shift register 1 (SIO1)

SIO1 is an 8-bit register which performs parallel-serial conversion and serial transfer (shift) operation in phase with the serial clock.

Serial transfer is started by writing data to SIO1.

In transmission, data written to SIO1 is output on the serial output (SO1). In reception, data is read from the serial input (SI1) into SIO1.

Data can be read from or written to SIO1 using an 8-bit manipulation instruction.

When the $\overline{\text{RESET}}$ signal is applied during operation, the value of SIO1 becomes undefined. When the $\overline{\text{RESET}}$ signal is applied in the standby mode, the value of SIO1 is preserved.

Shift operation is stopped after 8-bit transmission or reception is completed.

The timing for reading SIO1 and start of serial transfer (writing to SIO1) is as follows:

- When the serial interface operation enable/disable bit (CSIE1) is set to 1, except after data is written to shift register 1.
- When the serial clock is masked after 8-bit serial transfer
- When $\overline{\text{SCK1}}$ is high

5.8.4 Operation Halt Mode

The operation halt mode is used when serial transfer is not performed, which is set by setting 0 in CSIE1. This mode reduces power consumption.

Shift register 1 does not perform shift operation in this mode, so the shift register can be used as a normal 8-bit register.

The $\overline{\text{RESET}}$ signal places the device in the operation halt mode. The P82/SO1 and P83/SI1 pins function as input-only ports. The P81/ $\overline{\text{SCK1}}$ pin can be used as an input port by setting serial operation mode register 1.

5.8.5 Three-Wire Serial I/O Mode Operations

The three-wire serial I/O mode is compatible in other modes used in the 75X series, μ PD7500 series, and 78K series. This mode is set by setting CSIE1 to 1.

Communication is performed using three lines: Serial clock ($\overline{\text{SCK1}}$), serial output (SO1), and serial input (SI1).

The three-wire serial I/O mode transfers data in eight-bit units. Bits are transferred serially in phase with the serial clock.

Shift register 1 is triggered on the falling edge of the serial clock ($\overline{\text{SCK1}}$). Transmit data is latched on the SO1 latch, and is output on the SO1 pin. Receive data applied to the SI1 pin is latched in the shift register 1 on the rising edge of $\overline{\text{SCK1}}$.

When eight bits have been transferred, operation of shift register 1 automatically terminates, setting the serial transfer end flag (EOT).

Setting the serial transfer end flag (EOT) cannot release the standby function.

Figure 5-84. Timing of the Three-wire Serial I/O Mode

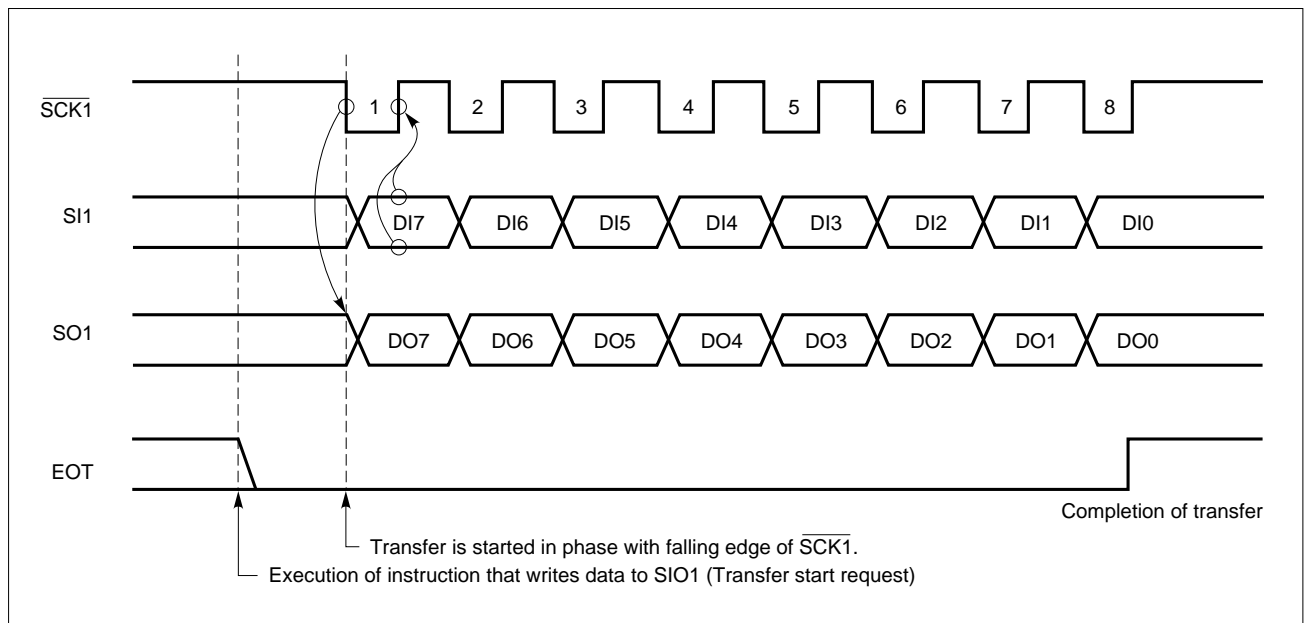

Table 5-15. Serial Clock Selection and Application

Mode register		Serial clock		Timing for shift register R/W and start of serial transfer	Application
CSIM0	CSIM0	Source	Masking of serial clock		
1	0				
0	0	External SCK1	Automatically masked when	<1> In the operation halt mode (CSIE0 = 0) <2> When the serial clock is masked after 8-bit transfer <3> When SCK1 is high	Slave CPU
0	1	TOUT flip-flop	8-bit data transfer is completed		—
1	0	$f_x/2^4$			Middle-speed serial transfer
1	1	$f_x/2^3$			High-speed serial transfer

An 8-bit transfer instruction is used to write to or read from shift register 1. The transfer starts with the MSB.

Example To transfer the RAM data specified by the HL register pair to SIO1, load the SIO1 data to the accumulator, and start serial transfer:

MOV XA,@HL ; Fetch transmit data from RAM

SEL MB15 ; or CLR1 MBE

XCH XA,SIO1 ; Exchange transmit data and receive data, and start transfer

5.8.6 Application of the Serial Interface (Channel 1)

This section describes how to use the serial interface (channel 1) in the three-wire serial I/O mode with an example.

Usually, communication using the serial interface is performed in the following steps.

- <1> A transfer mode is set. (Data is set in CSIM1.)
- <2> Data is written to SIO1, then start of transfer is directed. (MOV SIO1,XA or XCH XA,SIO1; in this case, transfer is automatically directed.)

Example Data is transferred starting with the MSB on a transfer clock of 262 kHz (in 4.19-MHz operation) (master operation).

<Sample program>

```

CLR1   MBE
MOV    XA,#10000010B
MOV    CSIM1,XA      ; Set transfer mode
MOV    XA,TDATA      ; TDATA is transfer data storage address
MOV    SIO1,XA       ; Set transfer data, and start transfer
    
```

Caution **A second or subsequent transfer can be started by setting data in SIO1 (MOV SIO1,XA or XCH XA,SIO1).**

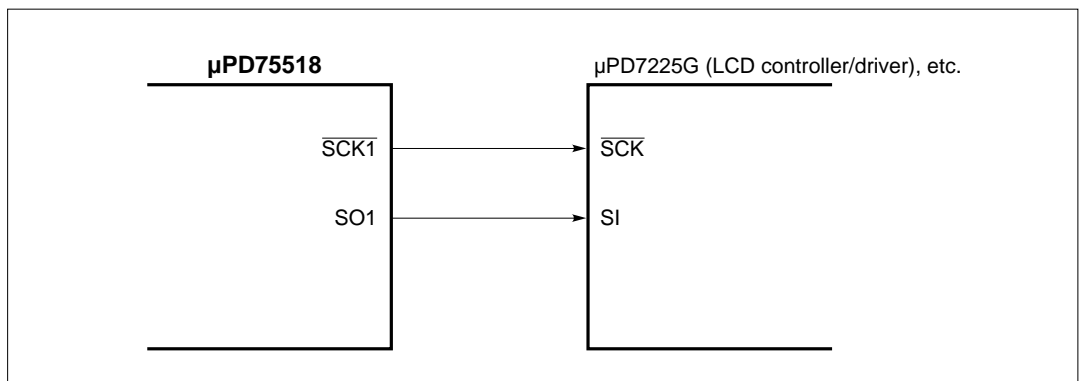

In this case, the SI1 pin on the μPD75518 can be used as an input.

5.9 A/D Converter

The μ PD75518 contains an 8-bit analog/digital (A/D) converter that has eight analog input channels (AN0 to AN7).

The A/D converter employs the successive-approximation method.

5.9.1 Configuration of the A/D Converter

Figure 5-85 shows the configuration of the A/D converter.

Figure 5-85. Block Diagram of the A/D Converter

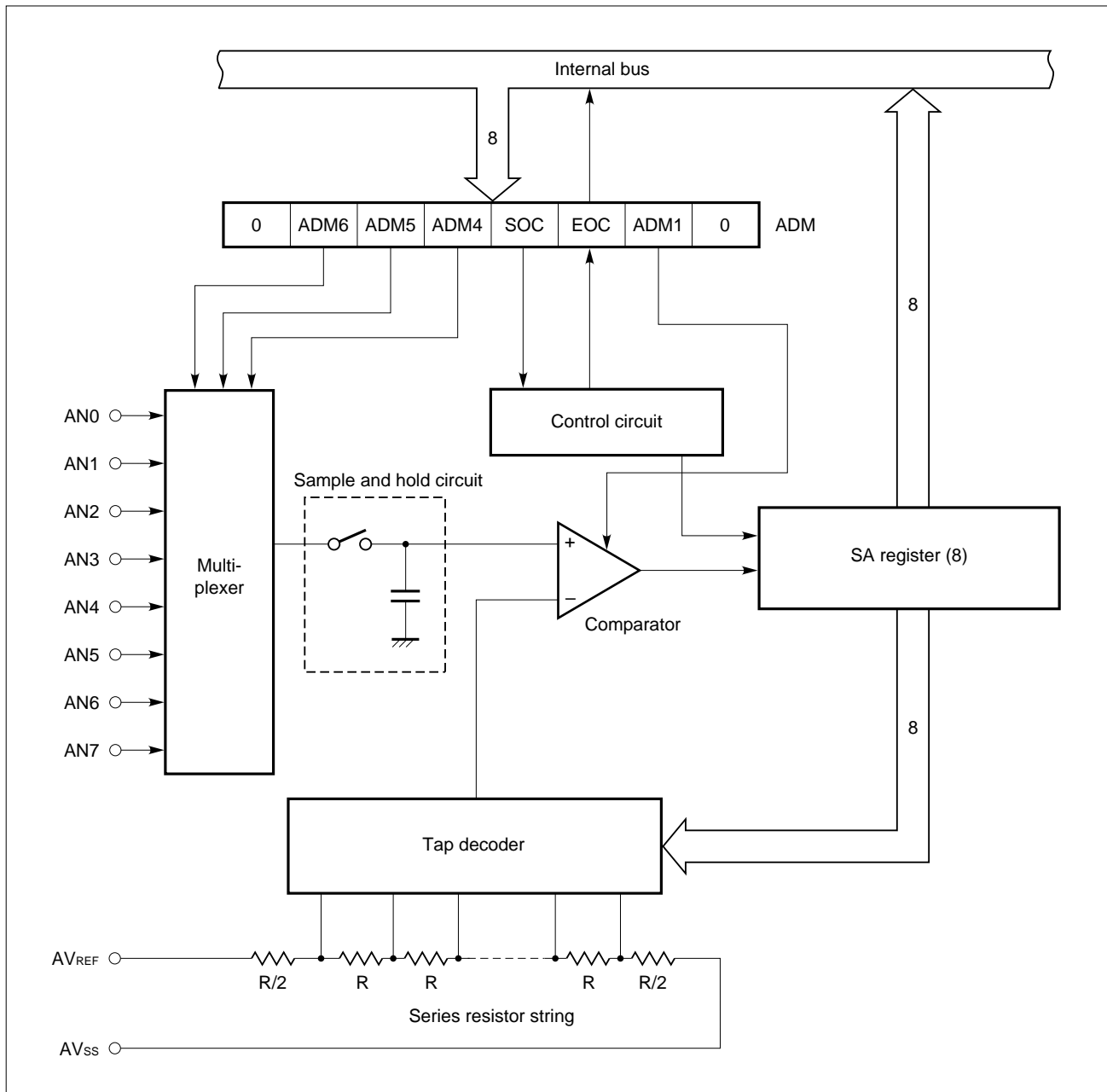

(1) Pins of the A/D converter

(a) AN0 to AN7

AN0 to AN7 are the input pins for eight analog signal channels. Analog signals subject to A/D conversion are applied to these pins.

The A/D converter contains a sample-and-hold circuit, and analog input voltages are internally maintained during A/D conversion.

Caution Do not apply voltage out of specification to AN0 to AN7 inputs. If a voltage higher than V_{DD} or lower than V_{SS} is applied even when the maximum absolute rating is not exceeded, the conversion result for an associated channel becomes unpredictable. In addition, the conversion results for other channels may be affected.

(b) AV_{REF}

A reference voltage for the A/D converter is applied to this pin.

By using an applied voltage across AV_{REF} and AV_{SS} , signals applied to AN0 to AN7 are converted to digital signals.

(c) AV_{SS}

The GND pin for the A/D converter.

Always use the same voltage as that of the V_{SS} pin.

(2) A/D conversion mode register (ADM)

The A/D conversion mode register (ADM) is an 8-bit register used to select analog input channels, direct the start of conversion, detect the completion of conversion, and select the comparator bias voltage.

ADM is set using an 8-bit manipulation instruction.

Bit 2 (EOC) and bit 3 (SOC) can be manipulated on a bit-by-bit basis.

A \overline{RESET} signal initializes ADM to 04H. That is, only EOC is set to 1, with all bits cleared to 0.

Figure 5-86 shows the format of ADM.

Figure 5-86. Format of the A/D Conversion Mode Register

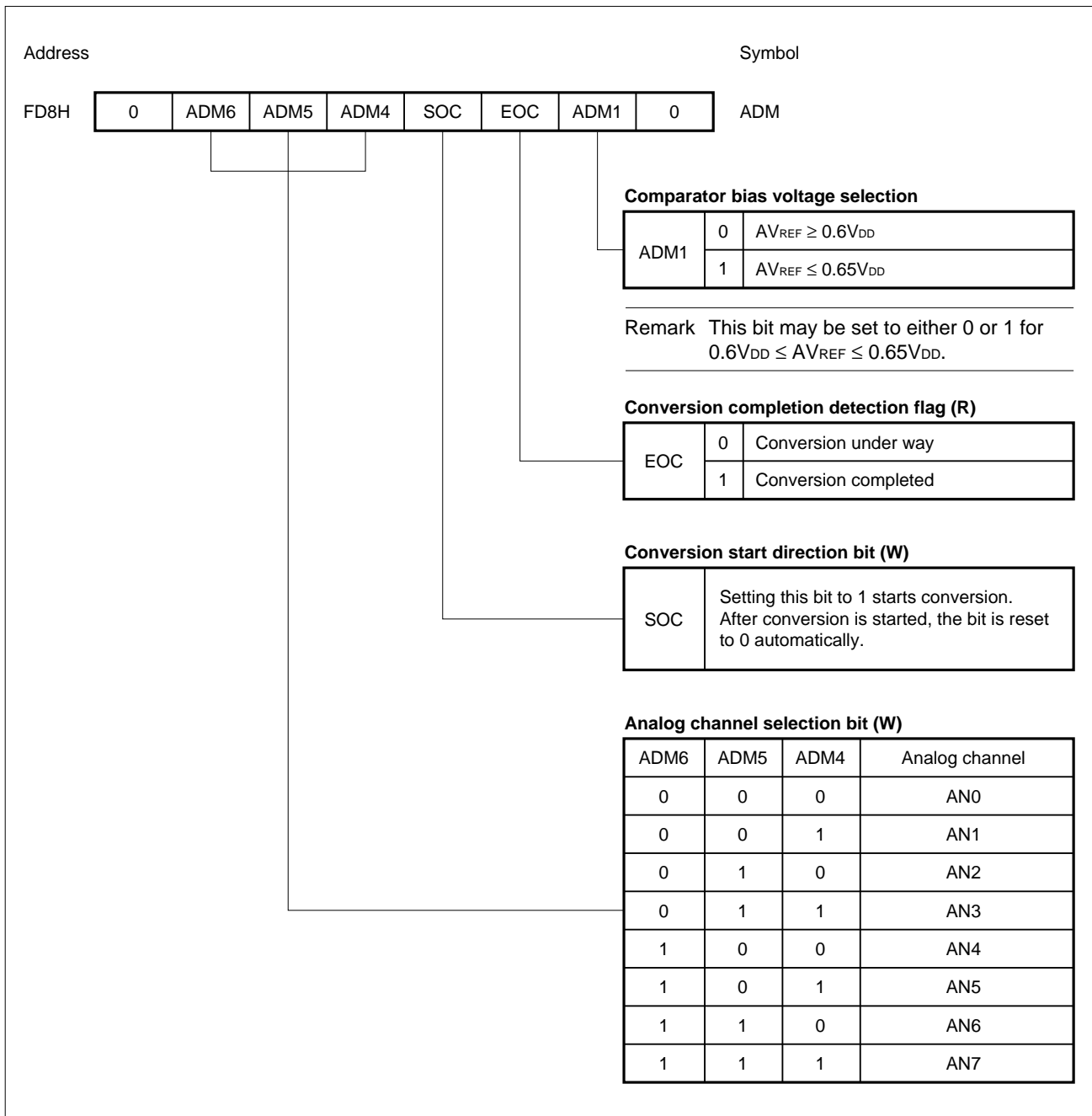

Caution A/D conversion is started a maximum of $2^4/f_X$ seconds ($2.67 \mu s$ at $f_X = 6.0 \text{ MHz}$)(Note) after SOC is set. (For details, see Section 5.9.2.)

(Note) $2^4/f_X = 3.81 \mu s$ at $f_X = 4.19 \text{ MHz}$

(3) Successive approximation (SA) register

The SA register is an 8-bit register to hold the result of A/D conversion.

SA is a read-only register from which data is read with an 8-bit manipulation instruction. No data can be bit-manipulated in SA.

A $\overline{\text{RESET}}$ signal makes SA undefined.

SA is mapped to address FDAH.

Caution **If A/D conversion is started with bit 3 (SOC) of the ADM register set to 1, the result of conversion in SA is destroyed, and SA becomes unpredictable until a new conversion result is stored.**

5.9.2 A/D Converter Operation

Analog input signals subject to A/D conversion are specified with bits 6, 5, and 4 of the A/D conversion mode register (ADM6, ADM5, and ADM4).

A/D conversion is started by setting bit 3 (SOC) of ADM to 1. After that, SOC is automatically cleared to 0. A/D conversion is performed by hardware using the successive-approximation method. The resultant 8-bit data is loaded into the SA register. Upon completion of A/D conversion, ADM bit 2 (EOC) is set to 1. Figure 5-87 shows the timing chart of A/D conversion.

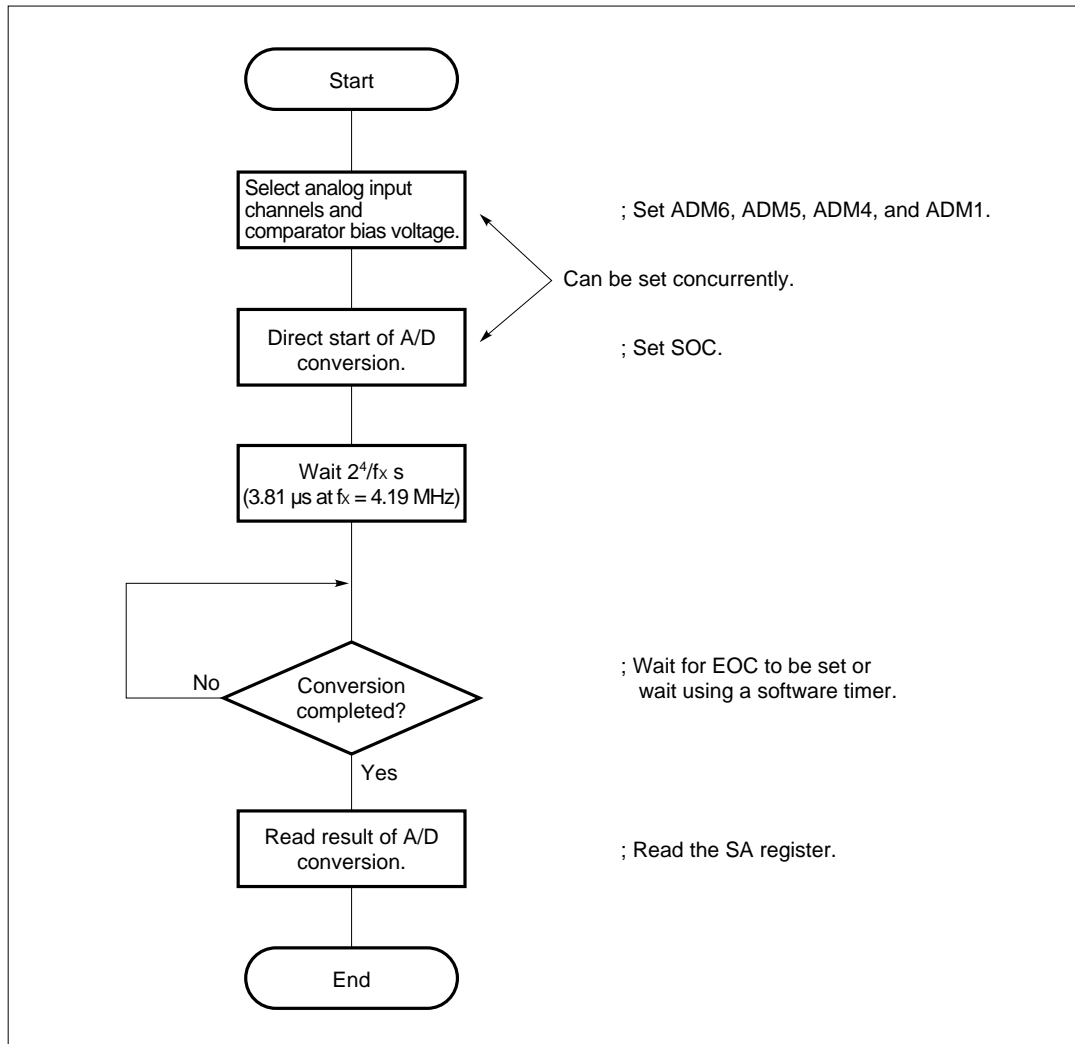

Caution There is a delay of up to $2^4/f_X$ seconds ($2.67 \mu\text{s}$ at $f_X = 6.0 \text{ MHz}$)(Note) from the setting of SOC to the clearing of EOC after A/D conversion is started. EOC must be tested when a time indicated in Table 5-16 has elapsed after the setting of SOC. Table 5-16 also indicates A/D conversion times.

(Note) $2^4/f_X = 3.81 \mu\text{s}$ at $f_X = 4.19 \text{ MHz}$

Table 5-16. Setting of SCC and PCC

Setting values of SCC, PCC				A/D conversion time	Wait time from SOC setting to EOC test	Wait time from SOC setting to A/D conversion completion
SCC3	SCC0	PCC1	PCC0			
0	0	0	0	168/f _X seconds(Note) (28.0 μs at f _X = 6.0 MHz)	Waiting not required	3 machine cycles
		0	1		1 machine cycle	11 machine cycles
		1	0		2 machine cycles	21 machine cycles
		1	1		4 machine cycles	42 machine cycles
0	1	x	x		Waiting not required	Waiting not required
1	x	x	x	Conversion stopped	—	—

(Note) 168/f_X = 40.1 μs (f_X = 4.19 MHz)

Remark x: Don't care

Figure 5-87. Timing Chart of A/D Conversion

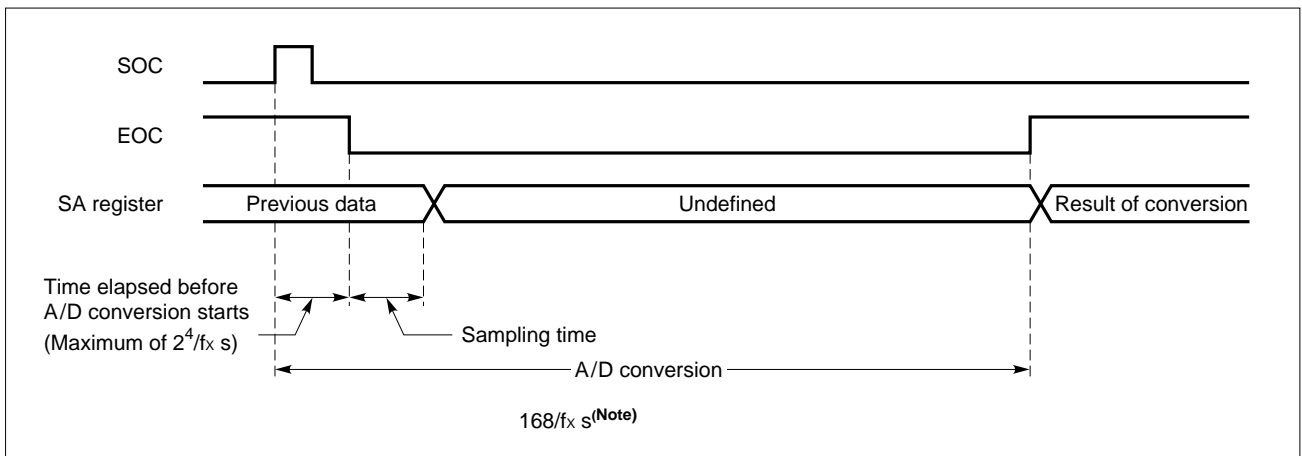

(Note) 168/f_X = 28.0 μs (f_X = 6.0 MHz)
 = 40.1 μs (f_X = 4.19 MHz)

Figure 5-88 shows the relationship between analog input voltages and 8-bit digital data obtained by A/D conversion.

Figure 5-88. Relationship (Ideal) between Analog Input Voltages and Results of A/D Conversion

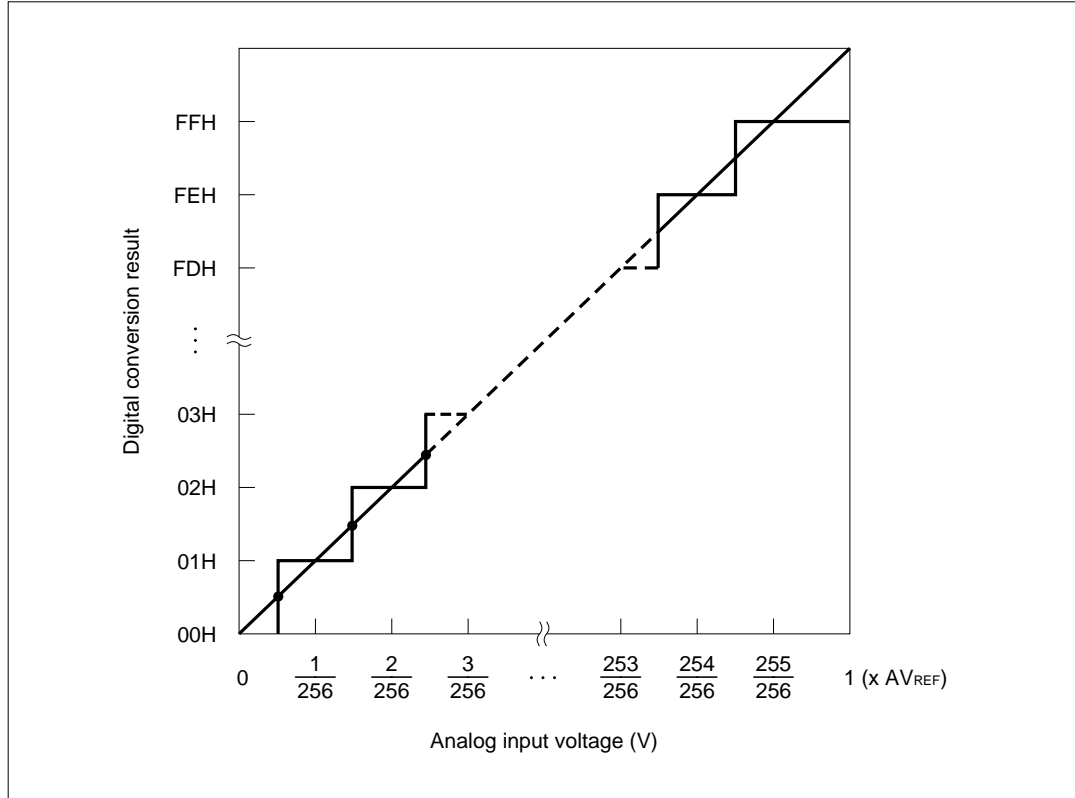

5.9.3 Notes on the Standby Mode

The A/D converter operates with the main system clock. So its operation stops in the STOP mode, or when the subsystem clock is used, in the HALT mode. A current flows through the AV_{REF} pin even when the A/D converter is stopped, so that the current must be stopped to reduce overall system power consumption. Since pin P113 has a higher drive capability than the other ports, it can supply voltage directly to the AV_{REF} pin (see **Figure 5-89**). In this case, however, the actual AV_{REF} voltage does not provide precision. This means that the value resulting from conversion does not provide precision and can be used only for relative comparison. In the standby mode, outputting a low on P113 can reduce power consumption.

The P113 pin of the peripheral hardware emulator μPD75390 used for emulation has the same drive capability as the other port. Accordingly, as shown in Figure 5-89, AV_{REF} observed during emulation is lower than AV_{REF} observed on the μPD75518, and so the conversion result obtained during emulation is not equal to that on the μPD75518.

Figure 5-89. Reducing Power Consumption in the Standby Mode

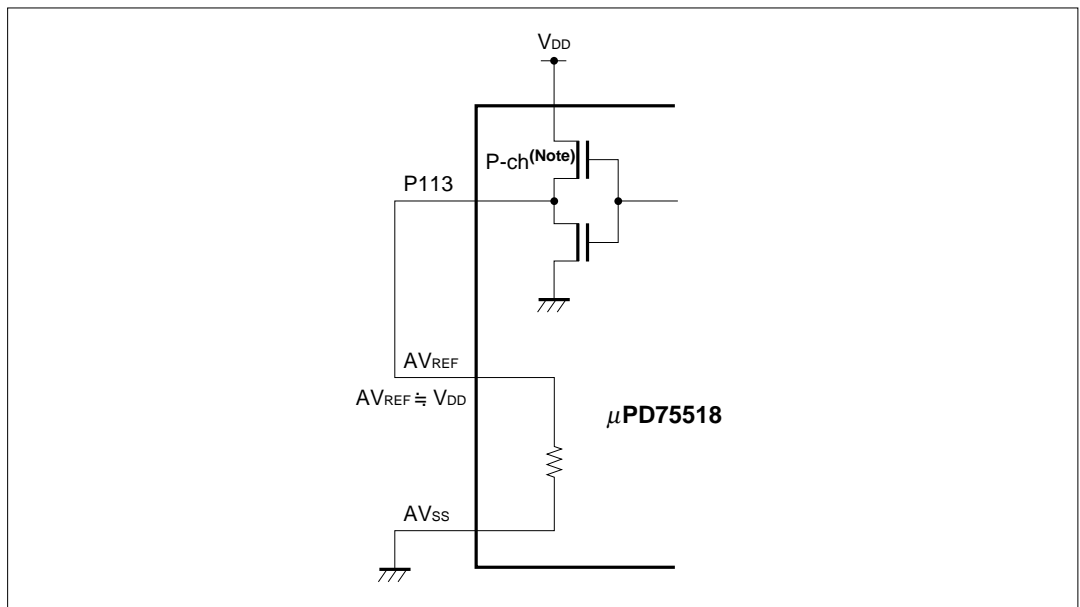

(Note) The drive capability of P-ch is higher than that of other ports.

5.9.4 Other Notes on Use

(a) AN0 to AN7 input range

Voltage out of specification must not be applied to AN0 to AN7 inputs. If a voltage higher than V_{DD} or lower than V_{SS} is applied even when the maximum absolute rating is not exceeded, the conversion result for the associated channel becomes unpredictable. In addition, the conversion results for other channels may be affected.

(b) Noise protection

To maintain 8-bit resolution, the user should pay attention to noise that may be applied to the AV_{REF} , and AN0 to AN7 pins. Noise adversely affects operation to a greater extent when the analog input source has a higher output impedance. As shown in Figure 5-90, a capacitor should be externally connected.

Figure 5-90. Analog Input Pin Connection

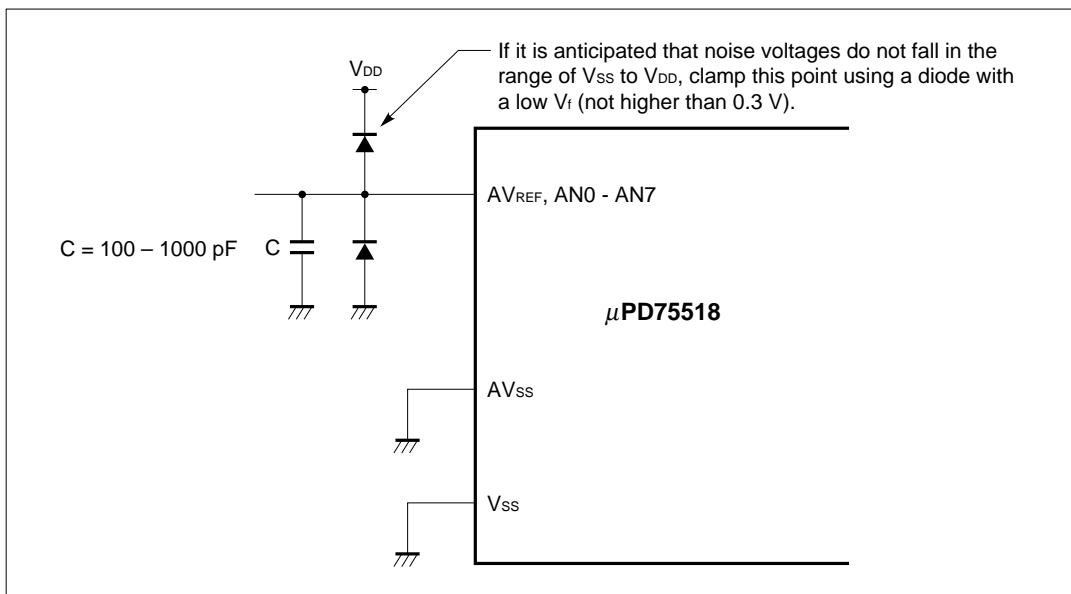

(c) AN4/P150 to AN7/P153 pins

The analog input pins (AN4 to AN7) are also used for an input port (PORT15). When any of AN4 to AN7 is selected for A/D conversion, no input instruction must be executed for PORT15 during A/D conversion. Otherwise, the precision of conversion may deteriorate.

If a digital pulse signal is applied to a pin adjacent to a pin being used for A/D conversion, an expected A/D conversion value may not be obtained because of coupling noise. So no digital pulse signal should be applied to a pin adjacent to a pin being used for A/D conversion.

5.9.5 Application of A/D Converter

Example Select channel 0 (AN0) for analog input, and set the following:

- SCC3, SCC0 = 0, 0
- PCC1, PCC0 = 1, 0

Use middle-speed mode.

<Sample program>

```
CLR1  MBE      ; or SEL MB15
MOV   XA,#08H  ; XA <- 00001000B
MOV   ADM,XA   ; Select AN0, and start A/D conversion
NOP                   ; Wait until EOC flag test
NOP                   ; Wait until EOC flag test
TEST: SKT   EOC   ; EOC flag test
BR    TEST
MOV   XA,SA    ; XA <- A/D conversion result
```

5.10 Bit Sequential Buffer: 16-bit

The bit sequential buffer (BSB) is special data memory for bit manipulations. In particular, the buffer allows bit manipulations to be performed very easily by sequentially changing address and bit specifications. So the buffer is useful in processing long data bit by bit.

This data memory consists of 16 bits, and allows `pmem.@L` addressing with a bit manipulation instruction. This addressing uses the L register for indirect bit specification. In this case, only by incrementing or decrementing the L register in a program loop, the bit to be manipulated can be sequentially shifted for continued processing.

Figure 5-91. Format of the Bit Sequential Buffer

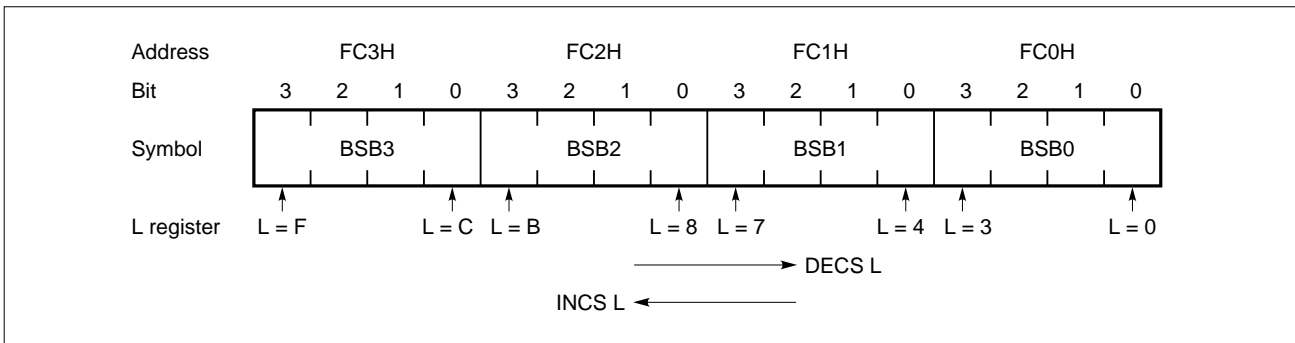

- Remarks
1. With `pmem.@L` addressing, bit specification is shifted according to the L register.
 2. With `pmem.@L` addressing, BSB can be manipulated at any time regardless of MBE/MBS specification.

Data can also be manipulated by direct addressing. The buffer can be used for applications such as continuous 1-bit data input or output operations by combining direct 1-bit, 4-bit, and 8-bit addressing with `pmem.@L` addressing. In 8-bit manipulation, the higher eight bits or lower eight bits are manipulated by specifying BSB0 or BSB2.

5.10.1 Applications of the Bit Sequential Buffer

- (1) 16-bit data in certain data memory areas BUFF1 and BUFF2 in memory bank 0 is output serially from bit 0 in port 3.

<Sample program>

```
CLR1    MBE
MOV     XA,BUFF1
MOV     BSB0,XA           ; Set BSB0 and BSB1
MOV     XA,BUFF2
MOV     BSB2,XA           ; Set BSB2 and BSB3
MOV     L,#0
LOOP:   MOV1  CY,BSB0.@L   ; CY <- specified bit in BSB
        MOV1  PORT3.0 CY   ; Bit 0 in port 3 <- CY
        INCS  L             ; L <- L + 1
        BR    LOOP
        RET
```

(2) Data is transmitted in arbitrary serial transfer format (1)

A serial transfer format shown in Figure 5-92 is used for data output. (P140 is used for serial data output, and P141 is used for the clock. The data to be transferred is already set in BSB2 and BSB3, and bit 3 of BSB1 is set to 1, and bit 2 is set to 0.)

Figure 5-92. Serial Transfer Format (I)

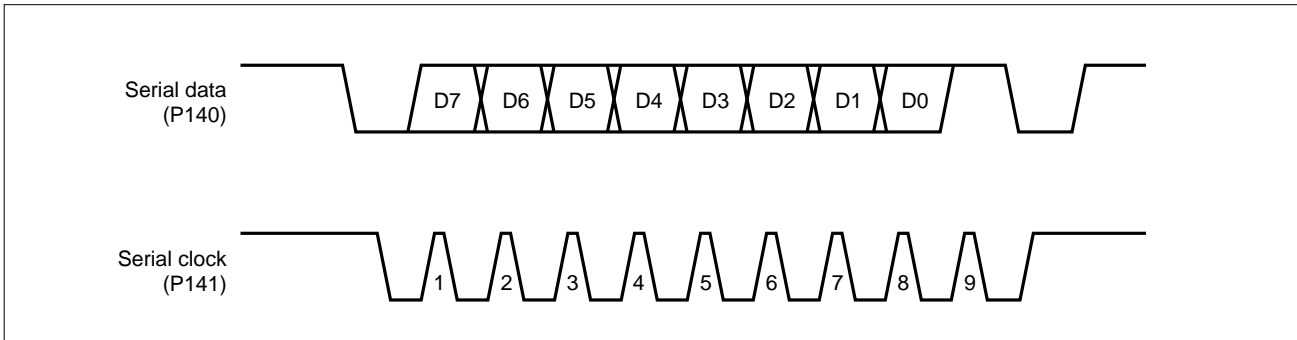

<Sample program>

```

MOV      L,#0FH
CLR1    PORT14.0      ; Start transfer
LOOP:   CLR1    PORT14.1  ; CLK <- 0
MOV1    CY,BSB0.@L
MOV1    PORT14.0,CY    ; Data output
SET1    PORT14.1      ; CLK <- 1
DECS    L
SKE     L,#5
BR      LOOP
SET1    PORT14.0      ; End transfer
    
```

(3) Data is transferred in arbitrary serial transfer format (2)

A serial transfer format shown in Figure 5-93 is used for data transmission. (Transmission data is 16-bit serial data, and is input and output on the P60 pin. $f_{\chi} = 4.19 \text{ MHz}$, and the minimum instruction execution time is $1 \mu\text{s}$.)

Figure 5-93. Serial Transfer Format (II)

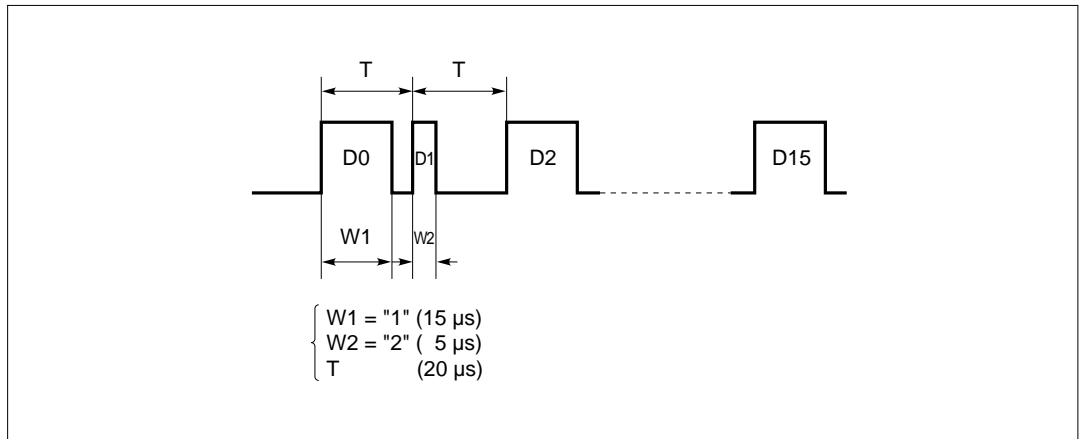

When data is transmitted and received alternately in the above data transfer format, only one signal line is needed for high-speed data transfer, as shown in Figure 5-94.

Figure 5-94. Bus Configuration Example

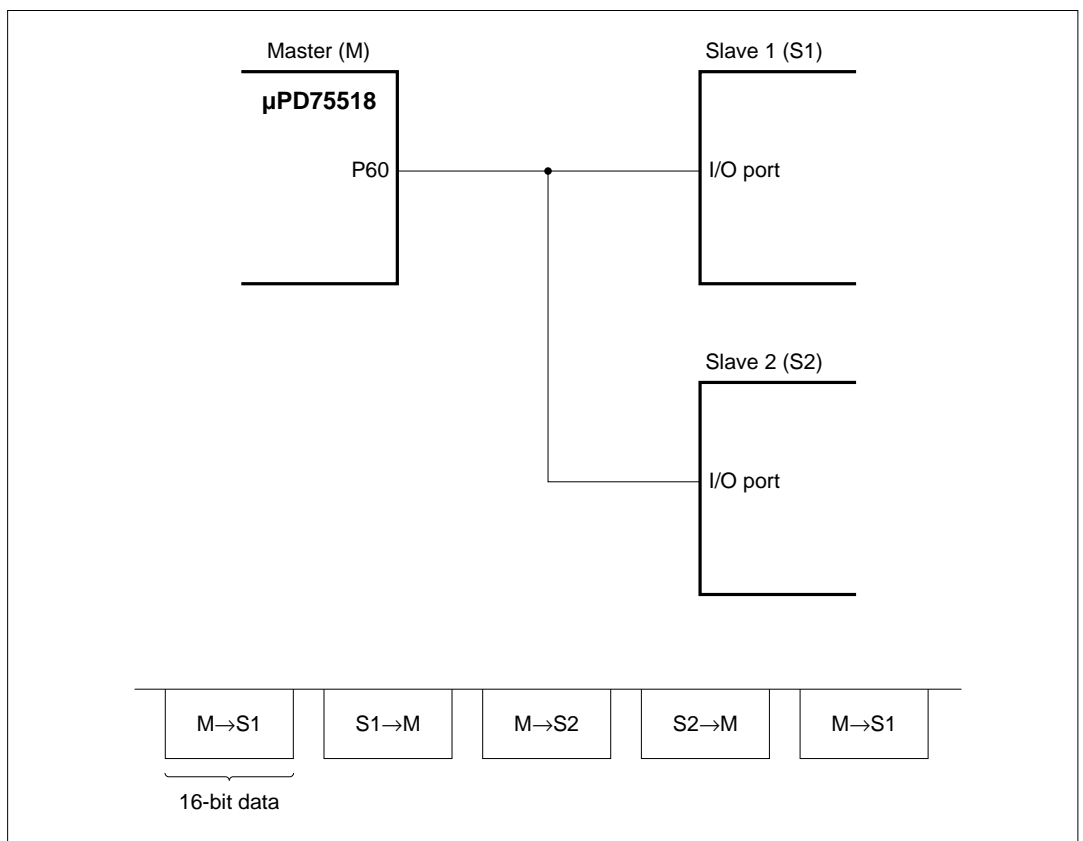

<Sample program for reception>

```
        MOV        L,#0
CHECK:  SKT        PORT6.0          ; P60=1?
        BR        CHECK          ; NO
        NOP              ; YES
        NOP
        NOP
        MOV1       CY,PORT6.0      ;
        MOV        BSB0.@L,CY
        NOP
        NOP
        INCS       L
        BR        CHECK
```

<Sample program for transmission>

```
        MOV        L,#0
LOOP:   SET1       PORT6.0          ; P60 <- 1
        MOV1       CY,BSB0.@L      ; CY <- transfer data
        NOP
        MOV1       PORT6.0,CY      ; P60 <- data
        MOV        A,#0EH          ; Wait for 8 machine cycles
WAIT:   INCS       A
        BR        WAIT
        NOP
        NOP
        CLR1       PORT6.0          ; P60 <- 0
        INCS       L
        BR        LOOP
```

Chapter 6

Interrupt Function

The μ PD75518 has seven vectored interrupt sources and two testable interrupt sources, allowing a wide range of applications.

In addition, the interrupt control circuitry of the μ PD75518 has the following features for very high-speed interrupt processing.

- (a) An interrupt master enable flag (IME) and interrupt enable flag (IE_{xxx}) are provided to control whether to accept interrupts.
- (b) An interrupt processing start address and the MBE and RBE for interrupt processing can be freely set using a vector table (to speed up the practical start of the interrupt service program).
- (c) By assigning a higher priority to a given interrupt source, multiple interrupt processing is enabled with that interrupt.
- (d) An interrupt request flag (IRQ_{xxx}) can be tested and cleared. (Generation of an interrupt can be checked by software.)
- (e) A standby mode (STOP or HALT) can be released by an interrupt request. (A release source can be selected using an interrupt enable flag.)

6.1 Configuration of the Interrupt Control Circuit

Figure 6-1 shows the configuration of the interrupt control circuit. Each hardware item is mapped to a data memory space.

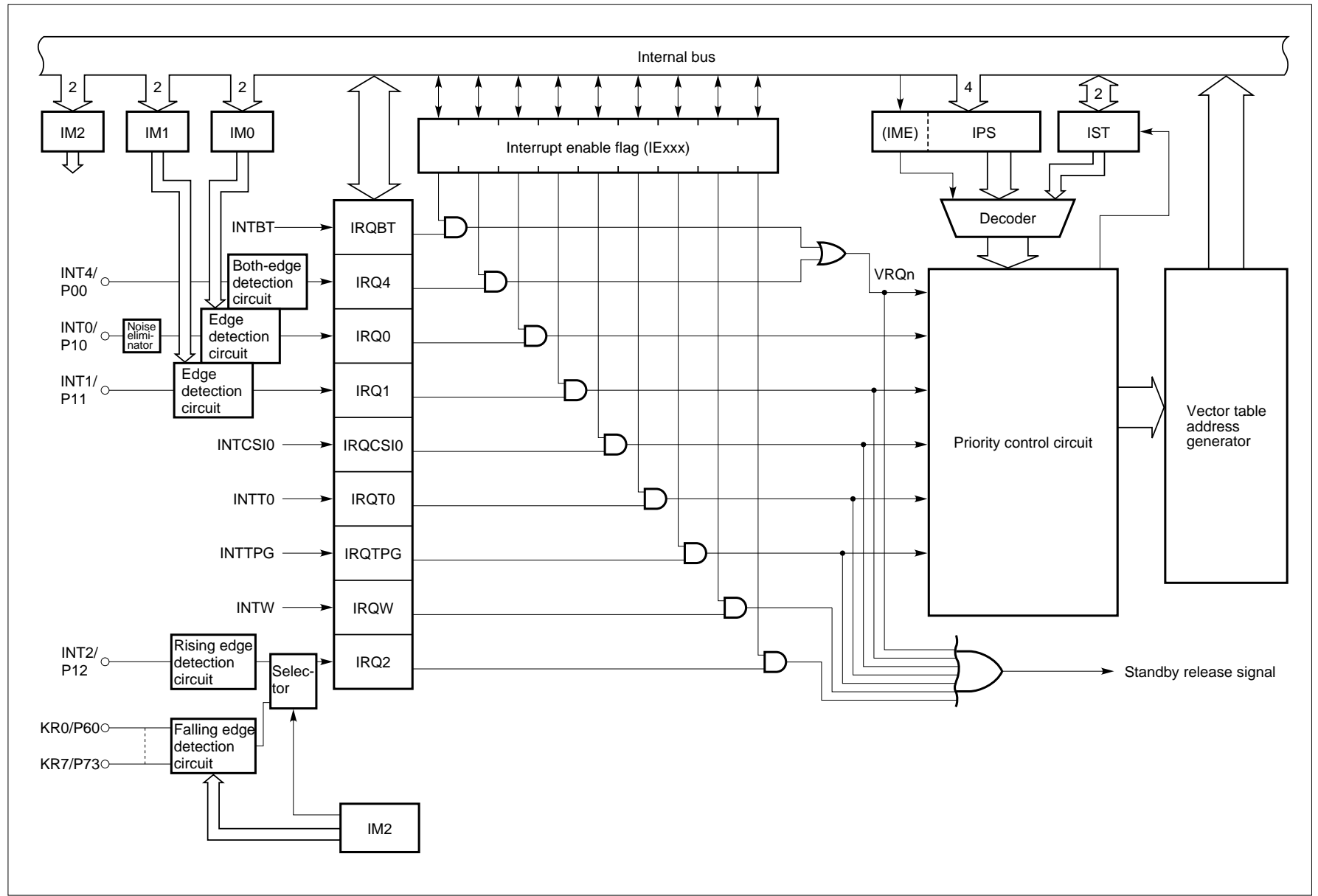

Figure 6-1. Block Diagram of Interrupt Control Circuit

6.2 Types of Interrupt Sources and Vector Tables

Table 6-1 lists the types of interrupt sources, and Figure 6-2 shows vector tables.

Table 6-1. Interrupt Sources

Interrupt source signal	In/out	Priority(Note 1)	Vectored interrupt request (vector table address)
INTBT [Reference time interval signal from basic interval timer]	In	1	VRQ1 (0002H)
INT4 [Detection of both rising and falling edges]	Out		
INT0 [Rising/falling edge]	Out	2	VRQ2 (0004H)
INT1 [detection specification]	Out	3	VRQ3 (0006H)
INTCSI0 [Serial data transfer completion signal]	In	4	VRQ4 (0008H)
INTT0 [Match signal between programmable timer/counter count register and modulo register]	In	5	VRQ5 (000AH)
INTTPG [Match signal from timer/pulse generator]	In	6	VRQ6 (000CH)
INT2(Note 3) [Rising edge detection for an INT2 pin input signal, or falling edge detection for either of KR0 to KR7 pin input signals(Note 2)]	Out	Testable input signal (Set IRQ2 and IRQW.)	
INTW(Note 3) [Signal from clock timer]			

(Note 1) The priority is used when two or more interrupt

(Note 2) See (3) in Section 6.3 for details on INT2.

(Note 3) These test sources are affected by corresponding interrupt enable flags like other interrupt sources. However, vectored interrupts are not issued.

Figure 6-2. Interrupt Vector Table

Address	MBE	RBE	INTBT/INT4 start address (high-order 6 bits)
			INTBT/INT4 start address (low-order 8 bits)
0002H	MBE	RBE	INT0 start address (high-order 6 bits)
			INT0 start address (low-order 8 bits)
0004H	MBE	RBE	INT1 start address (high-order 6 bits)
			INT1 start address (low-order 8 bits)
0006H	MBE	RBE	INTCS10 start address (high-order 6 bits)
			INTCS10 start address (low-order 8 bits)
0008H	MBE	RBE	INTT0 start address (high-order 6 bits)
			INTT0 start address (low-order 8 bits)
000AH	MBE	RBE	INTTPG start address (high-order 6 bits)
			INTTPG start address (low-order 8 bits)
000CH	MBE	RBE	INTTPG start address (high-order 6 bits)
			INTTPG start address (low-order 8 bits)

The column of interrupt priority in Table 6-1 indicates a priority assigned when multiple interrupt requests occur concurrently or are held.

A vector table contains interrupt processing start addresses and MBE and RBE setting values during interrupt processing. An assembler pseudo instruction (VENTn) is used to set a vector table.

Example A vector table is set for INTBT/INT4.

```

VENT1      MBE = 0,  RBE = 0,  GOTOBT
  ↑           ↑           ↑           ↑
  <1>        <2>        <3>        <4>
  
```

<1> Vector table at address 0002

<2> MBE setting value in interrupt service routine

<3> RBE setting value in interrupt service routine

<4> Symbol for indicating an interrupt service routine start address

Caution **The vector table specified by VENTn (n = 1 to 6) is located at address 2n.**

Example Vector tables are set for INTBT/INT4 and INTT0.

VENT1 MBE = 0, RBE = 0, GOTOBT

VENT5 MBE = 0, RBE = 1, GOTOT0

6.3 Various Devices of the Interrupt Control Circuit

(1) Interrupt request flags and interrupt enable flags

The following nine interrupt request flags (IRQxxx) corresponding to the interrupt sources (seven actual interrupts and two test interrupts) are provided.

INT0 interrupt request flag (IRQ0)	Serial interface interrupt request flag (IRQCSI0)
INT1 interrupt request flag (IRQ1)	Timer/event counter interrupt request flag (IRQTO)
INT2 interrupt request flag (IRQ2)	Timer/pulse generator interrupt request flag (IRQTPG)
INT4 interrupt request flag (IRQ4)	Watch timer interrupt request flag (IRQW)
BT interrupt request flag (IRQBT)	

An interrupt request flag is set to 1 by an interrupt request, and is automatically cleared to 0 when interrupt processing is performed. However, IRQBT and IRQ4 are cleared in a different way because these flags share a vector address. (See **Section 6.6.**)

The following nine interrupt enable flags (IExxx) corresponding to the interrupt request flags are provided.

INT0 interrupt enable flag (IE0)	Serial interface interrupt enable flag (IECSI0)
INT1 interrupt enable flag (IE1)	Timer/event counter interrupt enable flag (IETO)
INT2 interrupt enable flag (IE2)	Timer/pulse generator interrupt enable flag (IETPG)
INT4 interrupt enable flag (IE4)	Watch timer interrupt enable flag (IEW)
BT interrupt enable flag (IEBT)	

An interrupt enable flag set to 1 enables the corresponding interrupt, and an interrupt enable flag set to 0 disables the corresponding interrupt.

When an interrupt request flag and the interrupt enable flag are set to 1, a vectored interrupt request (VRQn) occurs. This condition is also used to release a standby mode.

A bit manipulation instruction or 4-bit memory manipulation instruction is used to manipulate an interrupt request flag and interrupt enable flag. A bit manipulation instruction allows direct manipulation regardless of MBE setting. An interrupt enable flag can be manipulated using an EI IExxx instruction or DI IExxx instruction. The SKTCLR instruction is usually used to test an interrupt request flag.

Example

```

EI      IE0      ; Enable INT0
DI      IE1      ; Disable INT1
SKTCLR  IRQCSI0 ; Skip and clear IRQCSI0 when it is set to 1.

```

When an interrupt request flag is set using an instruction, even if there is no interrupt request, a vectored interrupt is executed in the same way as when an interrupt is requested.

*

Inputting a $\overline{\text{RESET}}$ signal clears the interrupt request flags IRQ0, IRQBT, IRQCSI, IRQT0, and IRQW to 0. Since IRQ1, IRQ2, and IRQ4 are undefined after $\overline{\text{RESET}}$ signal input, clear them to 0 using software.

Inputting a $\overline{\text{RESET}}$ signal clears the interrupt enable flags to 0, disabling all interrupts.

Table 6-2. Set Signals for Interrupt Request Flags

Interrupt request flag	Set signals for interrupt request flags	Interrupt enable flag
IRQBT	Set by a reference time interval signal from the basic interval timer.	IEBT
IRQ4	Set by a detected rising or falling edge of an INT4/P00 pin input signal.	IE4
IRQ0	Set by a detected edge of an INT0/P10 pin input signal. The detection edge is specified by the INT0 mode register (IM0).	IE0
IRQ1	Set by a detected edge of an INT1/P11 pin input signal. The detection edge is specified by the INT1 mode register (IM1).	IE1
IRQCSI0	Set by a serial data transfer completion signal for the serial interface.	IECSI0
IRQT0	Set by a match signal from timer/event counter 0.	IET0
IRQTPG	Set by a match signal from the timer/pulse generator.	IETPG
IRQW	Set by a signal from the clock timer.	IEW
IRQ2	Set by a detected rising edge of an INT2/P12 pin input signal, or a detected falling edge of one of a KR0/P60 - KR7/P73 pin input signals.	IE2

(2) Configurations of the INT0, INT1, and INT4 circuits

- (a) As shown in Figure 6-3 (a), the INT0 circuit accepts an external interrupt at its rising or falling edge. The edge to be detected can be selected.

The INT0 circuit has a noise elimination function (see **Figure 6-4**), called a noise eliminator, using a sampling clock, which removes pulses shorter than two sampling clock cycles (**Note**) as noise. The INT0 circuit may accept pulses which are longer than one sampling clock cycle and shorter than two cycles as interrupts depending on the sampling timing (see **Figure 6-4 <2> (a)**). The circuit is sure to accept pulses equal to or longer than two sampling clock cycles as interrupts.

The INT0 pin is supplied with sampling clock Φ or $f_X/64$, whichever is selected by bit 3 of the edge detection mode register (IM03) (see **(a)** of **Figure 6-5**).

Bit 0 (IM00) and bit 1 (IM01) of the edge detection mode register are used to select a detection edge.

Figure 6-5 (a) shows the format of IM0. A 4-bit memory manipulation instruction is used to set IM0. A $\overline{\text{RESET}}$ signal clears all bits to 0, and a rising edge is specified to be detected.

(Note) When the frequency of a sampling clock is Φ , these cycles are equal to $2t_{CY}$. When the frequency of a sampling clock is $f_X/64$, these cycles are equal to $128/f_X$.

-
- Cautions 1. Since the INT0 input is sampled with a clock, INT0 does not operate in a standby mode.**
- 2. Input a pulse wider than two sampling clock cycles to the INT0/P10 pin. Otherwise, the pulse is suppressed as noise by a noise eliminator when the pin is used as a port.**
-

- (b) As shown in Figure 6-3 (b), the INT1 circuit accepts an external interrupt at its rising or falling edge.

The edge detection mode register (IM1) is used to select a detection edge.

Figure 6-5 (b) shows the format of IM1. A 4-bit manipulation instruction is used to set IM1. A $\overline{\text{RESET}}$ signal clears all bits to 0, and a rising edge is specified to be detected.

- (c) As shown in Figure 6-3 (c), the INT4 circuit accepts an external interrupt at its rising and falling edges.

Figure 6-3. Configurations of the INT0, INT1, and INT4 Circuits

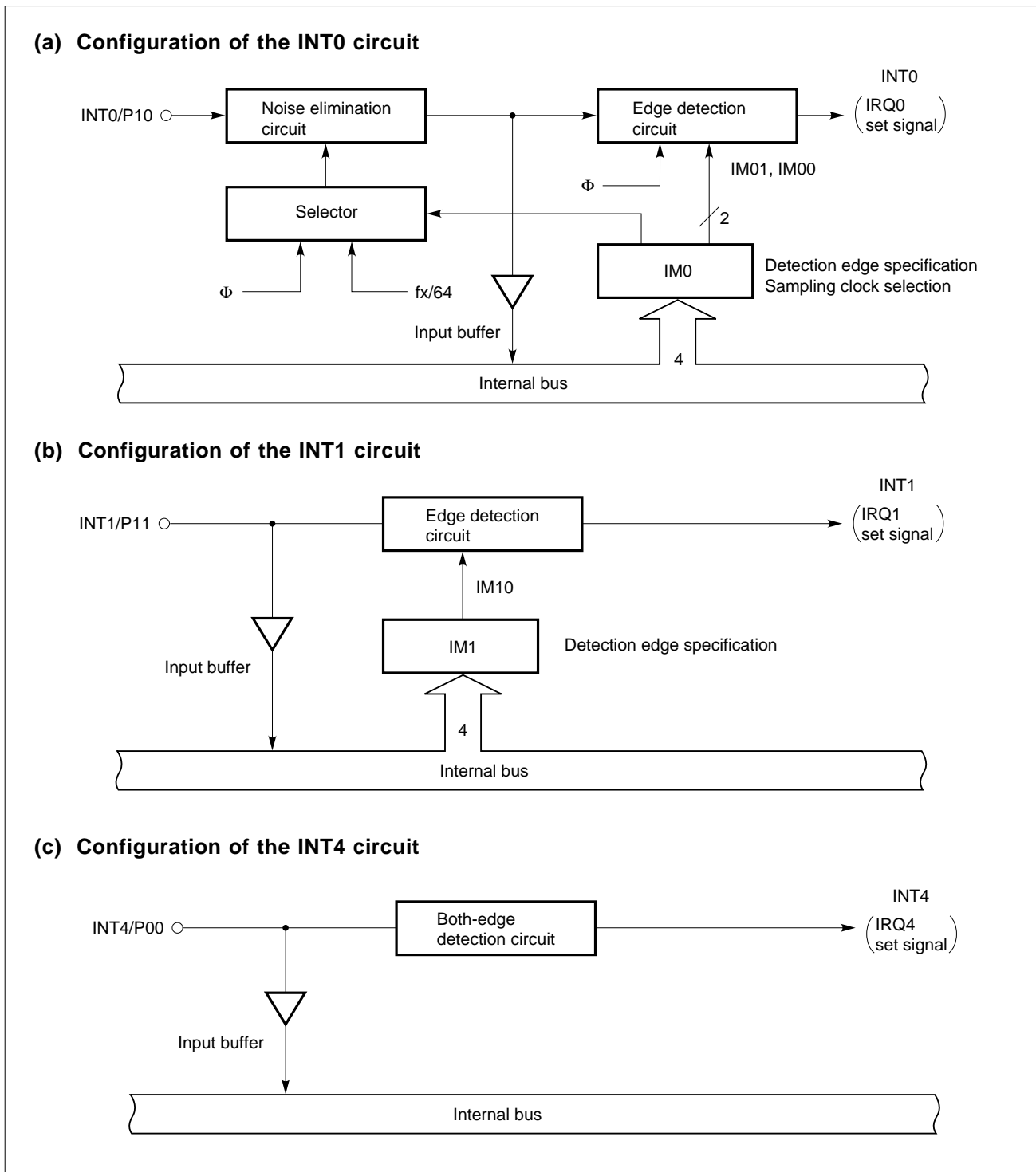
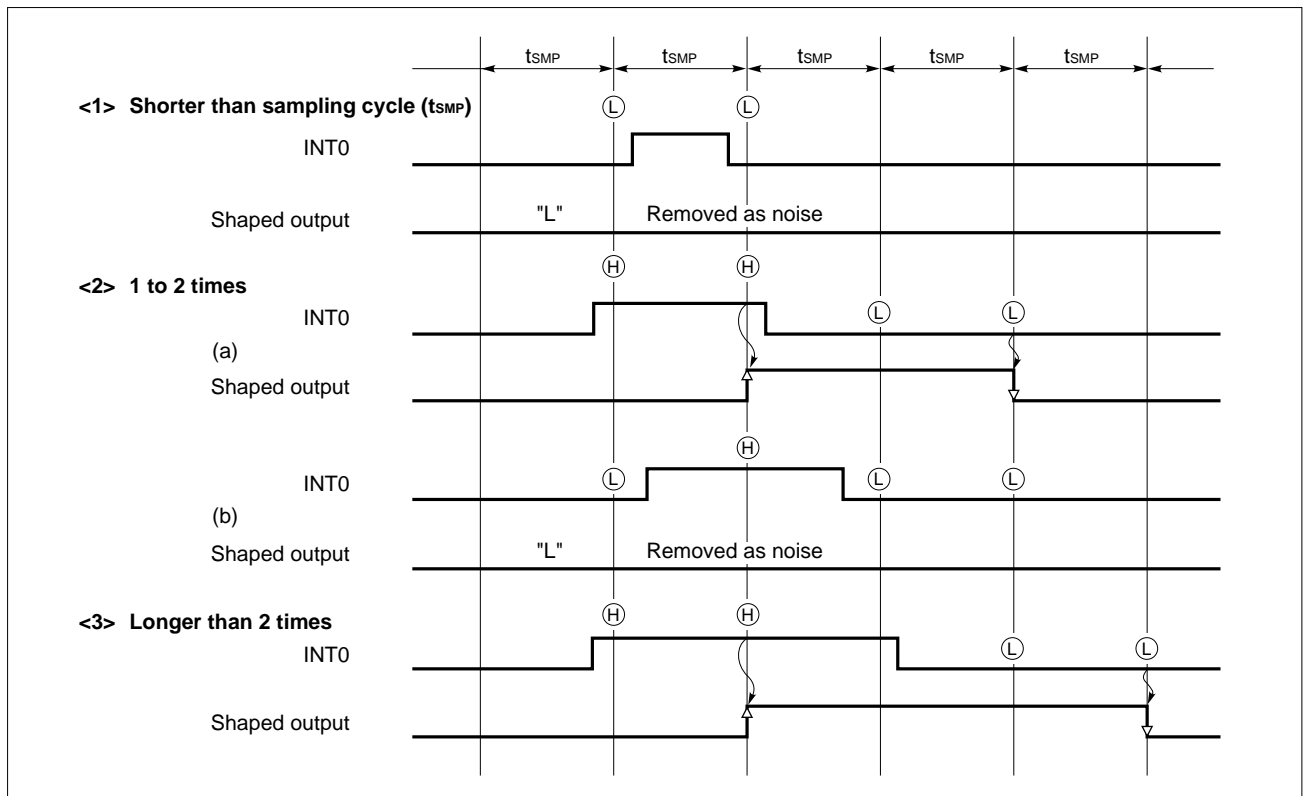
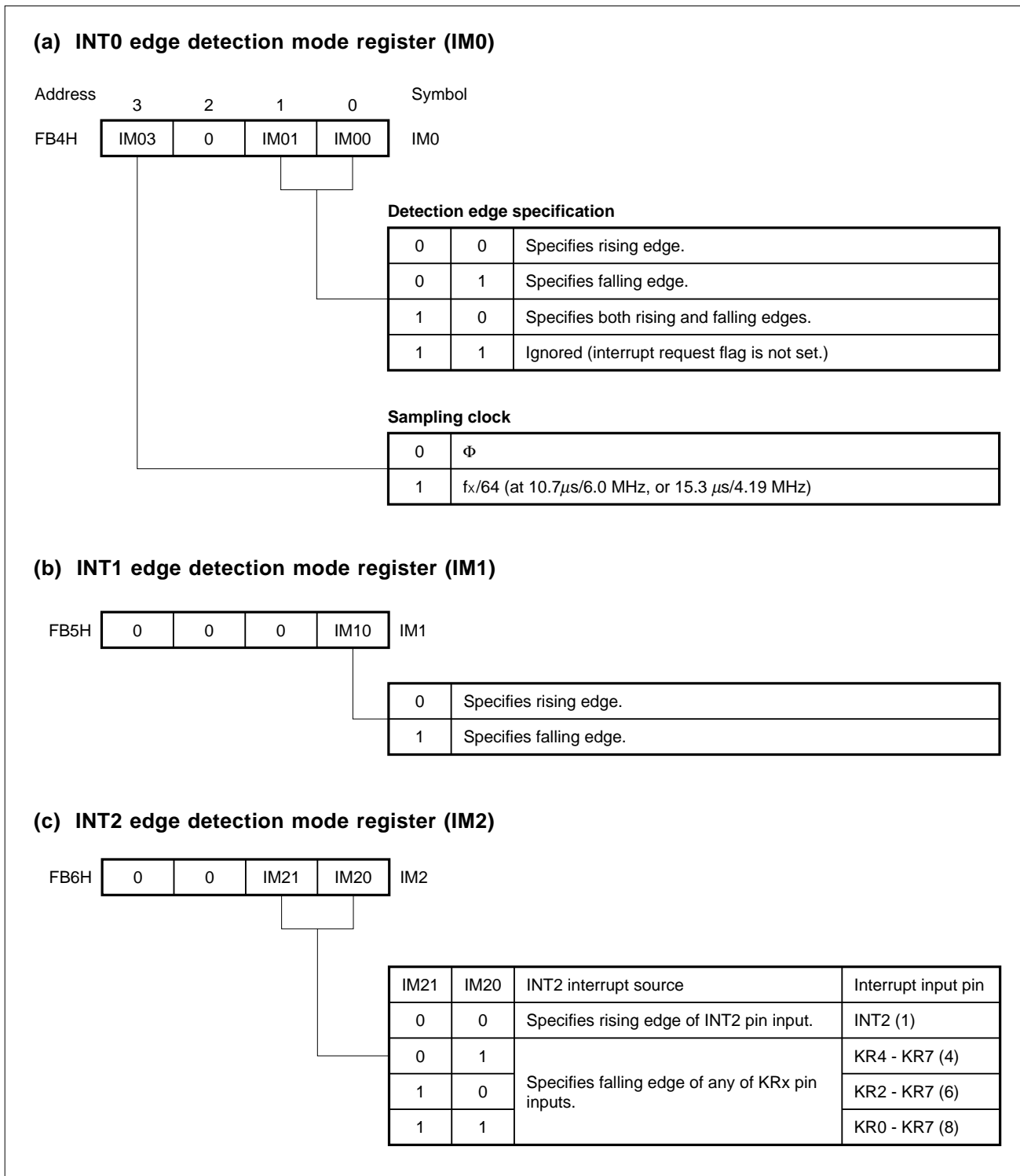

Figure 6-4. I/O Timing of a Noise Eliminator



Remark $t_{SMP} = t_{CY}$ or $64/f_X$

Figure 6-5. Format of Edge Detection Mode Registers



Caution is shown on the next page.

Caution Changing the edge detection mode register may set an interrupt request flag. So, disable the interrupts before changing the edge detection mode register. Then clear the interrupt request flag with a CLR1 instruction and enable the interrupts. When $f_x/64$ is selected as a sampling clock pulse in changing IM0, wait for 16 machine cycles after changing the mode register and clear the interrupt request flag.

(3) Configuration of the INT2 and KR0 to KR7 (key interrupt) circuits

Figure 6-6 shows the configuration of the INT2 and KR0 to KR7 circuits. IRQ2 is set at one of the following edges selected with the edge detection mode register (IM2):

(a) Detection of a rising edge of the INT2 pin input

When a rising edge of the INT2 pin input is detected, IRQ2 is set.

(b) Detection of a falling edge of one of the KR0 to KR7 pin inputs (key interrupt)

One of the pins KR0 to KR7 is selected to be used for an interrupt input pin with the edge detection mode register (IM2). When a falling edge of an input signal applied to the selected pin is detected, IRQ2 is set.

Caution If any of the selected pins has been supplied with a low-level signal, a falling edge appearing on another pin does not set IRQ2.

Figure 6-5 (c) shows the format of IM2. A 4-bit memory manipulation instruction is used to set IM2. A $\overline{\text{RESET}}$ signal clears all bits to 0, and a rising edge is selected for INT2.

Phase-out/Discontinued

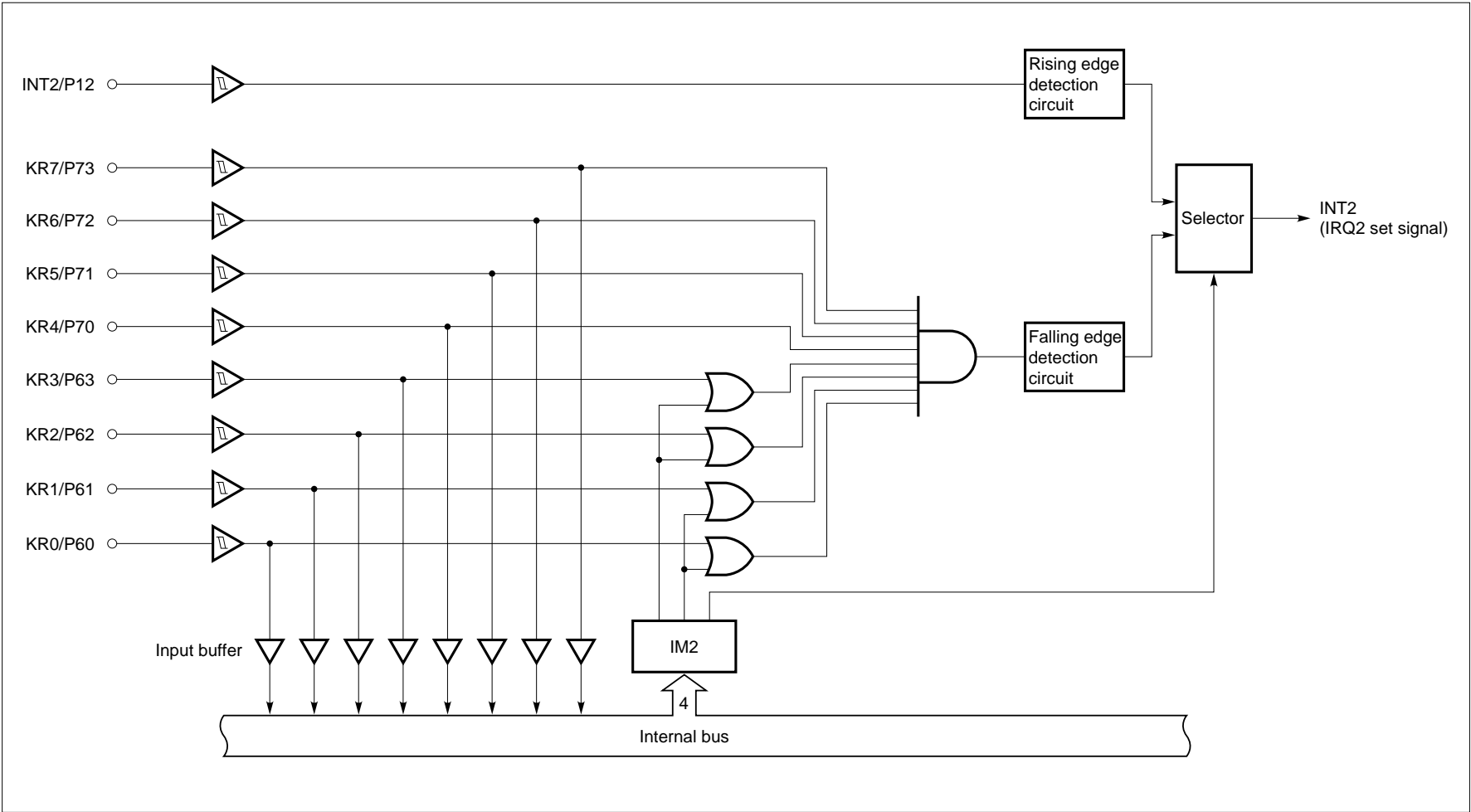

Figure 6-6. Configuration of the INT2 and KR0 to KR7 Circuits

(4) Interrupt priority specification register (IPS)

The interrupt priority specification register selects an interrupt with a higher priority from multiple interrupts using the low-order three bits.

Bit 3, interrupt master enable flag (IME), specifies whether to disable all interrupts.

The IPS is set using a 4-bit memory manipulation instruction. Bit 3 is set by an EI instruction and reset by a DI instruction.

When changing the low-order three bits of the IPS, interrupts must be disabled (IME = 0) beforehand.

A $\overline{\text{RESET}}$ signal clears all bits to 0.

Figure 6-7 shows the format of the interrupt priority specification register.

Example

```
DI          ; Disable interrupts
CLR1  MBE
MOV  A,#1011
MOV  IPS,A  ; Assign a higher priority to INT1, then enable interrupts.
```

Figure 6-7. Interrupt Priority Specification Register

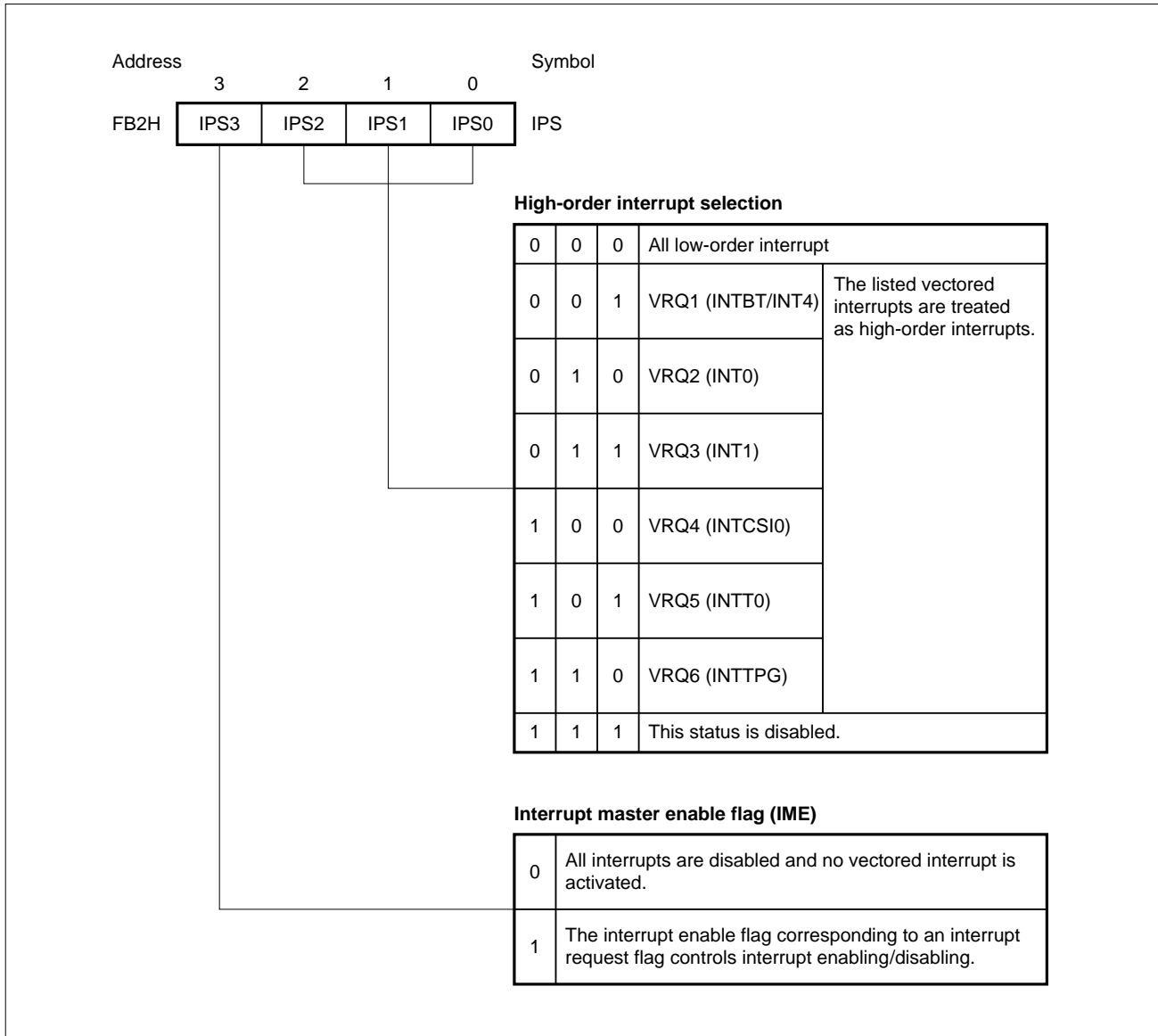

(5) Interrupt status flags

The interrupt status flags (IST0 and IST1), which are contained in the PSW, indicate the status of processing currently executed by the CPU.

By using the content of these flags, the interrupt priority control circuit controls multiple interrupts as indicated in Table 6-3.

A 4-bit manipulation instruction or bit manipulation instruction can be used to set and reset IST0 and IST1, so that multiple interrupts are enabled by changing the current status of execution. IST0 and IST1 can be manipulated on a single-bit basis at any time regardless of MBE setting.

Before IST0 or IST1 is manipulated, the DI instruction must be executed to disable interrupts, then the EI instruction must be executed to enable interrupts.

IST1 and IST0 as well as the other PSW bits are saved in the stack memory when an interrupt is accepted and the status of IST0 and IST1 changes to a status one level higher. When a RETI instruction is executed, the former values of IST1 and IST0 are resumed.

A $\overline{\text{RESET}}$ signal clears the content of the flag to 0.

Table 6-3. Interrupt Processing Statuses of IST0 and IST1

IST1	IST0	Processing status	CPU operation	Interrupts that can be accepted	After acceptance		
					IST1	IST0	
0	0	Status 0	Is processing the normal program.	All	0	1	
0	1	Status 1	Is processing a low- or high-order interrupt.	Only high-order interrupts	1	0	
1	0	Status 2	Is processing a high-order interrupt.	No	—	—	
1	1	This status cannot be used. (This status is disabled.)					

6.4 Interrupt Sequence

When an interrupt occurs, it is processed using the procedure shown in Figure 6-8.

Figure 6-8. Interrupt Processing Sequence

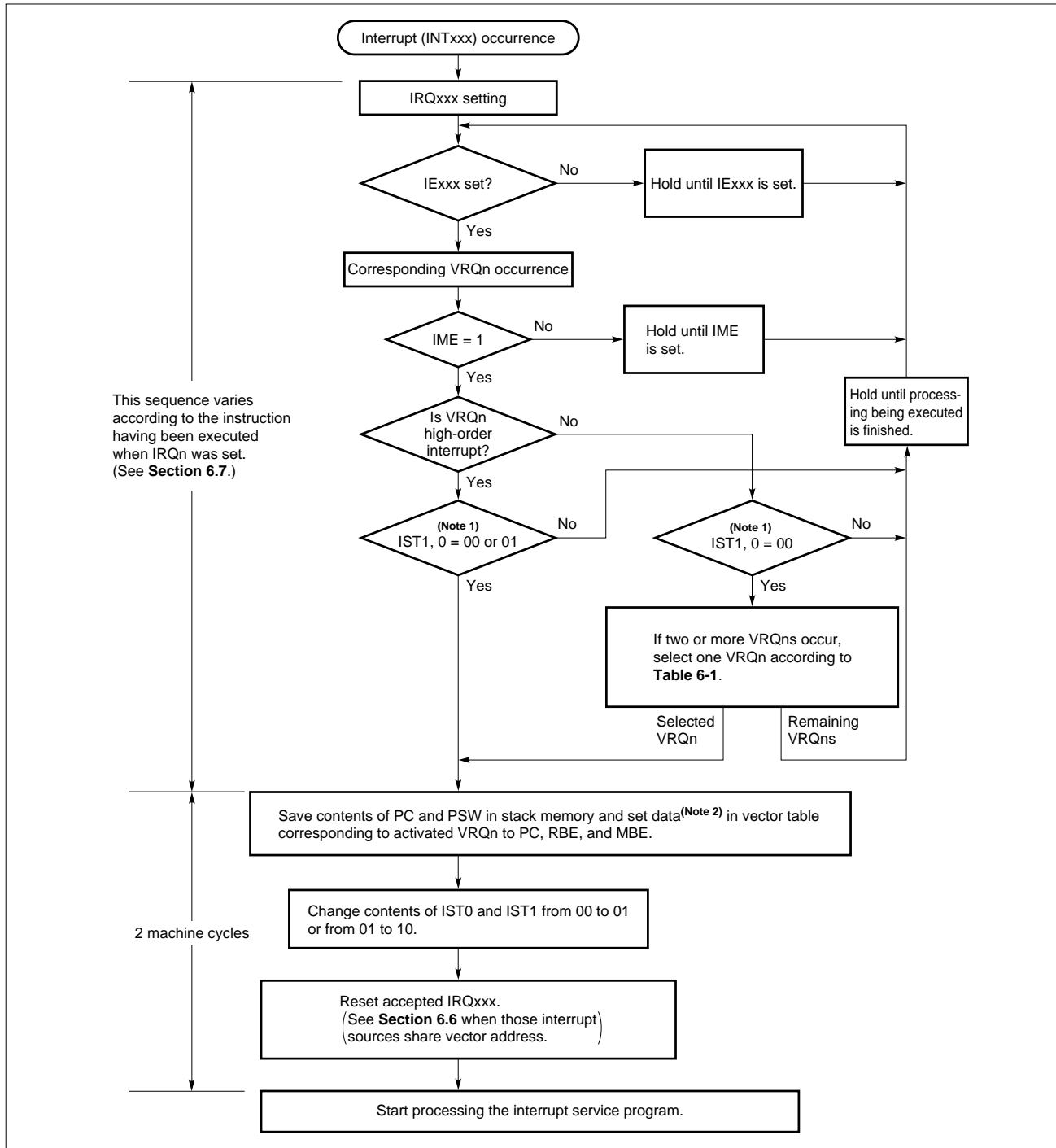

(Note 1) IST0 and IST1 are the interrupt status flags (bits 3 and 2 of the PSW). (See Table 6-3.)

(Note 2) An interrupt service program start address and MBE and RBE setting values at the start of interrupt are stored in each vector table.

6.5 Multiple Interrupt Processing Control

The μ PD75518 can handle multiple interrupts by either of the following methods.

(1) Multiple interrupt processing by a high-order interrupt

In this method, the μ PD75518 selects an interrupt source among multiple interrupt sources, enabling double interrupt processing.

That is, the high-order interrupt specified by the interrupt priority specification register (IPS) is enabled when the processing status is 0 or 1. Other interrupts (interrupts lower than the specified high-order interrupt) are enabled only when the status is 0. (See **Figure 6-9**.)

When only one interrupt is used as a level-two interrupt, using this method saves the user the trouble of enabling or disabling interrupts during an interrupt processing, and holds down the number of nesting levels to two.

Figure 6-9. Multiple Interrupt Processing by a High-order Interrupt

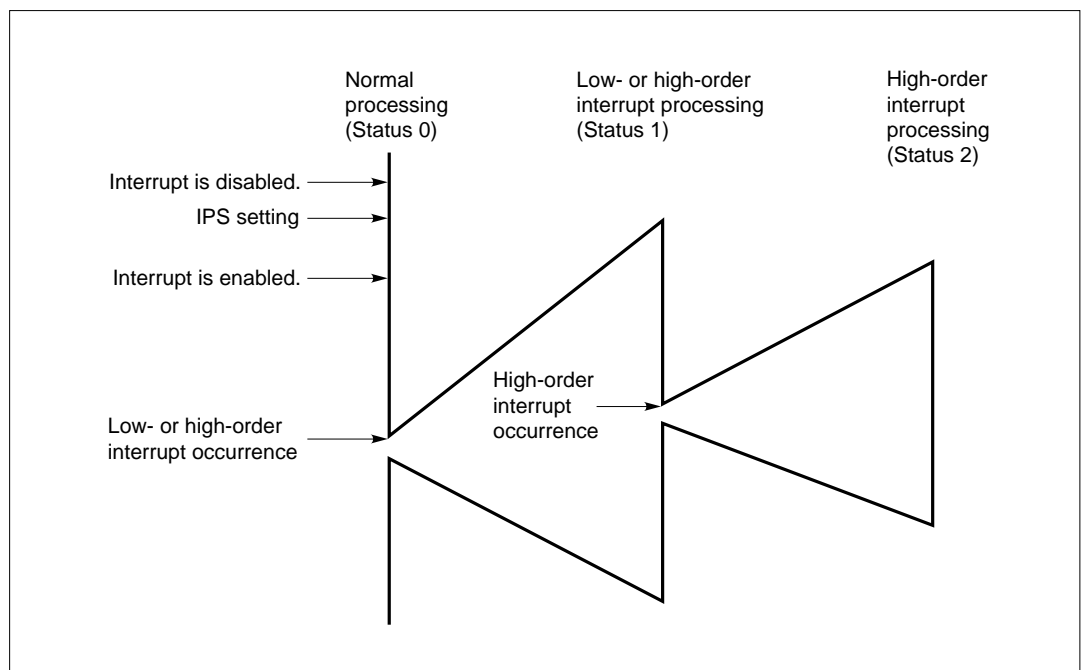

(2) Multiple interrupt processing by changing the interrupt status flags

Changing the interrupt status flags with the program causes multiple interrupts to be enabled. That is, when the interrupt processing program changes both IST1 and IST0 to 0 (status 0), multiple interrupt processing is enabled.

This method is used when two or more interrupts are to be enabled at a time or when the processing of three or more interrupts is to be performed.

When changing IST1 and IST0, interrupts must be disabled beforehand with a DI instruction.

Figure 6-10. Multiple Interrupt Processing by Changing the Interrupt Status Flags

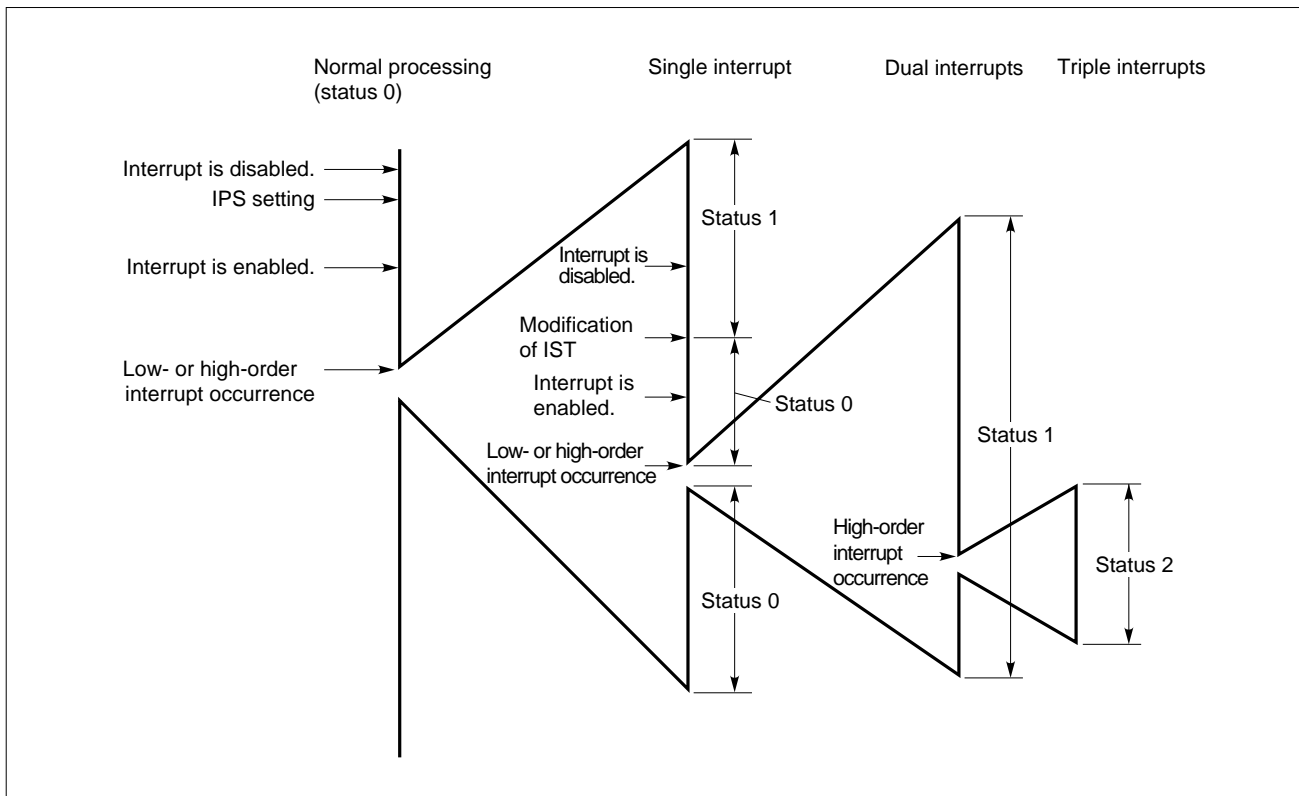

6.6 Processing of Interrupts Sharing a Vector Address

Interrupt sources INTBT and INT4 share a vector table, so an interrupt source is selected as described below.

(1) Using only one interrupt

The interrupt enable flag for desired one of the two interrupt sources sharing a vector table is set to 1, and the interrupt enable flag for the other is cleared to 0. In this case, the enabled (IE_{xxx} = 1) interrupt source causes an interrupt request. When the interrupt request is accepted, the interrupt request flag is reset. (The same operation as that of interrupts not sharing a vector address)

(2) Using both interrupts

The interrupt enable flags corresponding to the two interrupt sources are both set to 1. In this case, the logical sum of the interrupt request flags for the two interrupt sources is used as an interrupt request.

In this case, even if an interrupt request or interrupt requests caused by the setting of one or both of the interrupt request flags are accepted, the interrupt request flag or flags are not reset.

Accordingly, which of the two interrupt sources caused the interrupt needs to be determined using the interrupt service routine. For this determination, the DI instruction is to be executed at the start of the interrupt service routine, and the interrupt request flags are checked with the SKTCLR instruction.

If both interrupt request flags are set, an interrupt request remains even when one interrupt request flag is tested and cleared. When this interrupt is given a higher priority, the remaining interrupt request starts two-level interrupt processing.

That is, the interrupt request not to be tested is processed first. When the interrupt is given a lower priority, on the other hand, the remaining interrupt request is held, and the tested interrupt request is processed first. As indicated in Table 6-4, the method to determine the sharing interrupt varies depending on whether the interrupt is high-order or low-order.

Table 6-4. Determination of an Interrupt Source

For high-order interrupt	Disable the interrupt, and test the interrupt request flag to which priority is given.
For low-order interrupt	Test the interrupt request flag of the interrupt source to which priority is given.

* **Example 1.** Both INTBT and INT4 are used as high-order interrupts, and INT4 is given a higher priority.

```

DI
SKTCLR   IRQ4   ; IRQ4=1?
BR       VSUBBT
      ⋮
EIRETI:  EI
      RETI
      ⋮
VSUBBT:  SKTCLA  IRQBT   ; IRQBT=1?(Note)
BR       EIRETI ; IRQBT∨IRQ4=0
      ⋮
BR       EIRETI   INTBT service routine
    
```

(Note) Always test those interrupts which are not assigned a higher priority.

Example 2. Both INTBT and INT4 are used as low-order interrupts, and INT4 is given a higher priority.

```

SKTCLR   IRQ4   ; IRQ4=1?
BR       VSUBBT
      ⋮
      RETI
      ⋮
VSUBBT:  CLR1    IRQBT
      ⋮
      RETI
    
```

6.7 Machine Cycles for Starting Interrupt Processing

With the 75X series, the following machine cycles are used to start the execution of the interrupt service routine after an interrupt request flag (IRQn) is set.

(1) When IRQn is set during execution of an interrupt control instruction

When IRQn is set during execution of an interrupt control instruction, an instruction preceded by that instruction is executed, and an interrupt processing of three machine cycles is executed, then the interrupt service routine is started.

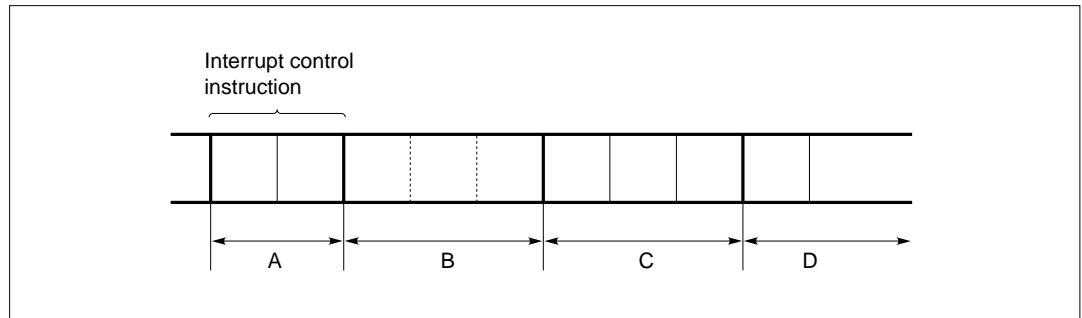

A: IRQn is set.

B: The next instruction is executed (1 to 3 machine cycles according to the instruction).

C: Interrupt processing (3 machine cycles)

D: Interrupt service routine is executed.

- Remarks
1. An interrupt control instruction manipulates hardware (address FBx in data memory) which handles interrupt processings. There are two types of interrupt control instruction, a DI instruction and an EI instruction.
 2. Three machine cycles required for the interrupt processing include the time to manipulate the stack when an interrupt is accepted.

- Cautions**
1. When a series of interrupt control instructions is executed, an instruction preceded by the interrupt control instruction executed last is executed, and an interrupt processing of three machine cycles is executed, then the interrupt service routine is started.
 2. When a DI instruction is executed in the period during which IRQn is set (A in the figure), or in the immediately following period (B in the figure), the interrupt request of the set IRQn is held until an EI instruction is executed.

(2) When IRQn is set during an instruction other than that described in (1)

(a) When IRQn is set at the last machine cycle of the instruction being executed

In this case, an instruction preceded by the instruction being executed is executed, and an interrupt processing of three machine cycles is executed, then the interrupt service routine is started.

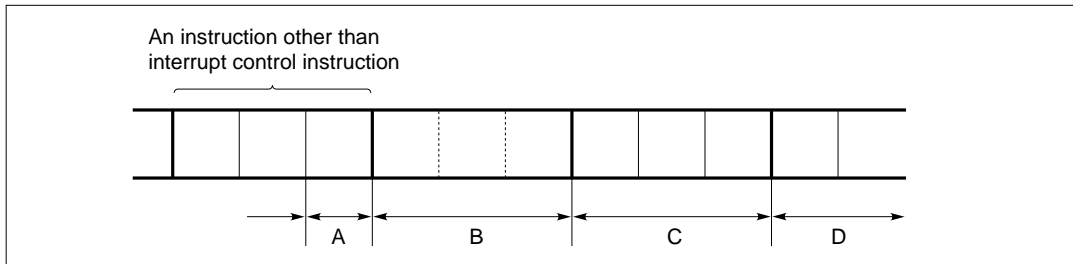

- A: IRQn is set.
- B: The next instruction is executed (1 to 3 machine cycles to the instruction).
- C: Interrupt processing (3 machine cycles)
- D: Interrupt service routine is executed.

Caution When one or more interrupt control instructions follow, an instruction preceded by the interrupt control instructions is executed, and an interrupt processing of three machine cycles is executed, then the interrupt service routine is started. When an instruction to be executed after setting IRQn is a DI instruction, the interrupt request of the set IRQn is held.

(b) When IRQn is set earlier than the last machine cycle of the instruction being executed

In this case, after executing the instruction being executed, an interrupt processing of three machine cycles is executed, then the interrupt service routine is started.

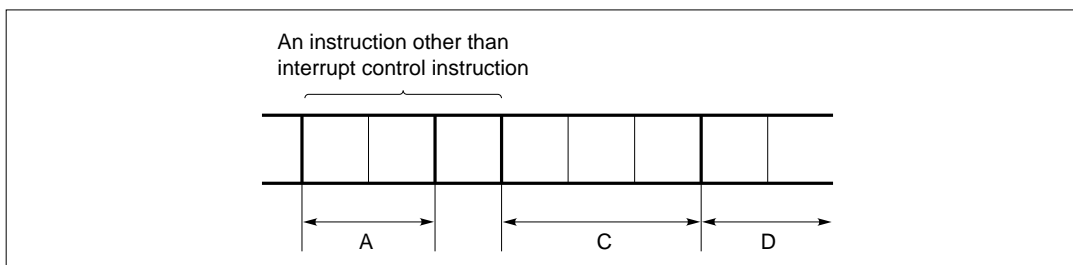

- A: IRQn is set.
- C: Interrupt processing (3 machine cycles)
- D: Interrupt service routine is executed.

6.8 Effective Use of Interrupts

The interrupt function can be used more effectively in the ways described below.

(1) MBE = 0 is set for the interrupt service routine

By allocating addresses 00H to 7FH as data memory used by the interrupt service routine and specifying MBE = 0 in an interrupt vector table, the user can code a program without being concerned with a memory bank.

If a program must use memory bank 1 for some reason, save the memory bank select register using the PUSH BS instruction before selecting memory bank 1.

(2) Register banks are selected depending on whether the routine is a normal or an interrupt

In a normal routine, register banks 2 and 3 are used by specifying RBE = 1 and RBS = 2. In a level-one interrupt processing, register bank 0 is selected by specifying RBE = 0 to save the user the trouble of saving and restoring registers. In a level-two interrupt processing, RBE = 1 is specified, the register bank is saved using the PUSH BS instruction, and register bank 1 is selected.

(3) Use of a software interrupt for debugging

Setting an interrupt request flag using an instruction has the same effect as the occurrence of an interrupt. Debug operation for irregular interrupts or concurrently occurring interrupts can be performed more efficiently by setting the interrupt request flags using an instruction.

6.9 Interrupt Applications

To use the interrupt function, a main program must:

- (a) Set a desired interrupt enable flag (using the EI IExxx instruction)
- (b) Select an active edge when INT0 or INT1 is used (set IM0 or IM1)
- (c) Set IPS when a level-two interrupt (high-order interrupt) is used (can set IME concurrently.)
- (d) Set the interrupt master enable flag using the EI instruction

When the interrupt service program is used, MBE and RBE are set in a vector table. When an interrupt given a higher priority is processed, however, register banks need to be saved and set with appropriate values.

The RETI instruction is used to return from the interrupt service program.

(1) Interrupt enable/disable

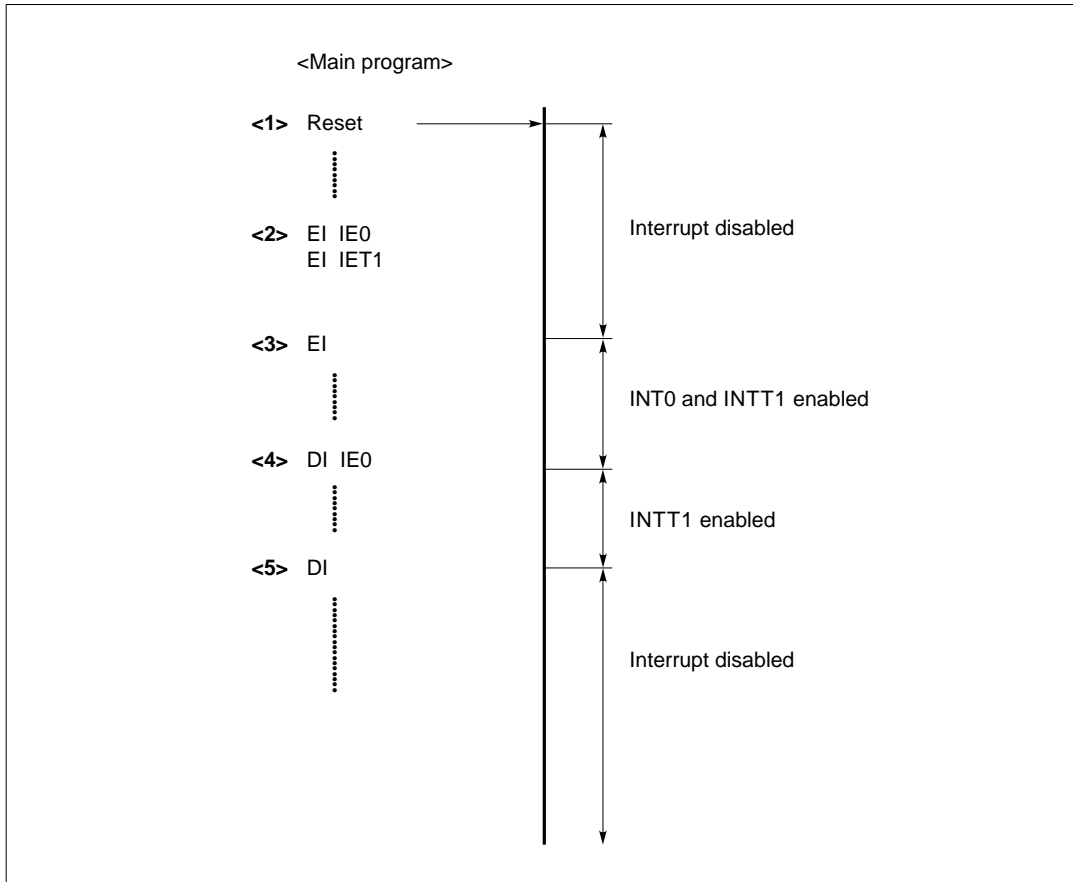

- <1> A $\overline{\text{RESET}}$ signal disables all interrupts.
- <2> Interrupt enable flags are set by the EI IE_{xx} instruction. At this stage, all interrupts are disabled.
- <3> The interrupt master enable flag is set by the EI instruction. At this stage, INT0 and INTT1 are enabled.
- <4> An interrupt enable flag is cleared by the DI IE_{xx} instruction to disable INT0.
- <5> The DI instruction disables all interrupts.

(2) Example of using INTBT, INT0 (falling edge active), and INTT0 without multiple interrupt processing (Interrupts are all low-order.)

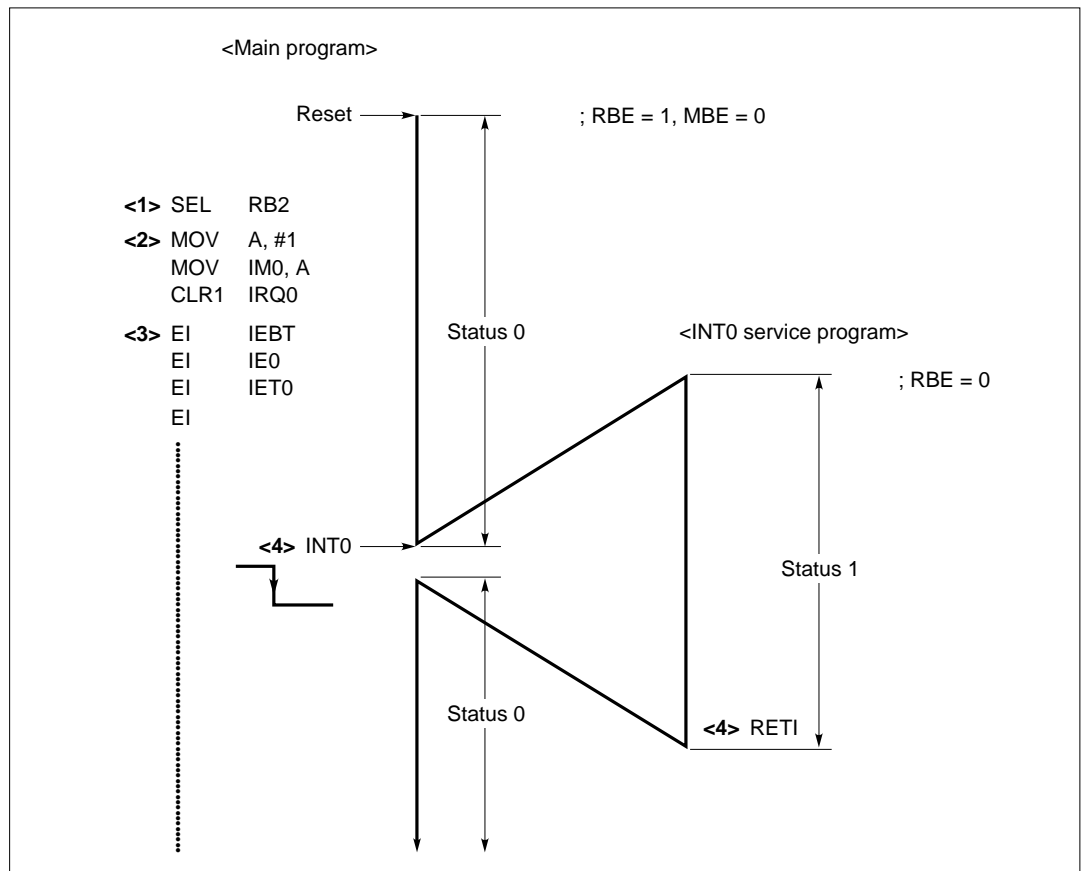

- <1> A $\overline{\text{RESET}}$ signal disables all interrupts, setting status 0. RBE = 1 is specified in the reset vector table, and register banks 2 and 3 are selected by the SEL RB2 instruction.
- <2> INT0 is set to be falling edge active.
- <3> Interrupts are enabled by the EI and EI IExxx instructions.
- <4> On the falling edge of INT0, the INT0 interrupt service program is started, status is set to 1, and all interrupts are disabled. RBE = 0 is set, and register banks 0 and 1 are used.
- <5> Control is returned from the interrupts by the RETI instruction, status 0 is set again, and interrupts are enabled.

Remark As shown in the example above, when all interrupts are given lower priorities, selecting register banks 2 and 3 by setting RBE = 1 and RBS = 2 in the main program or selecting register banks 0 and 1 by setting RBE = 0 in the interrupt program saves the user the trouble of saving/restoring registers.

(3) Multiple interrupt processing with high-order interrupt (with INTBT handled as high-order and INTT0 and INTCSI0 handled as low-order)

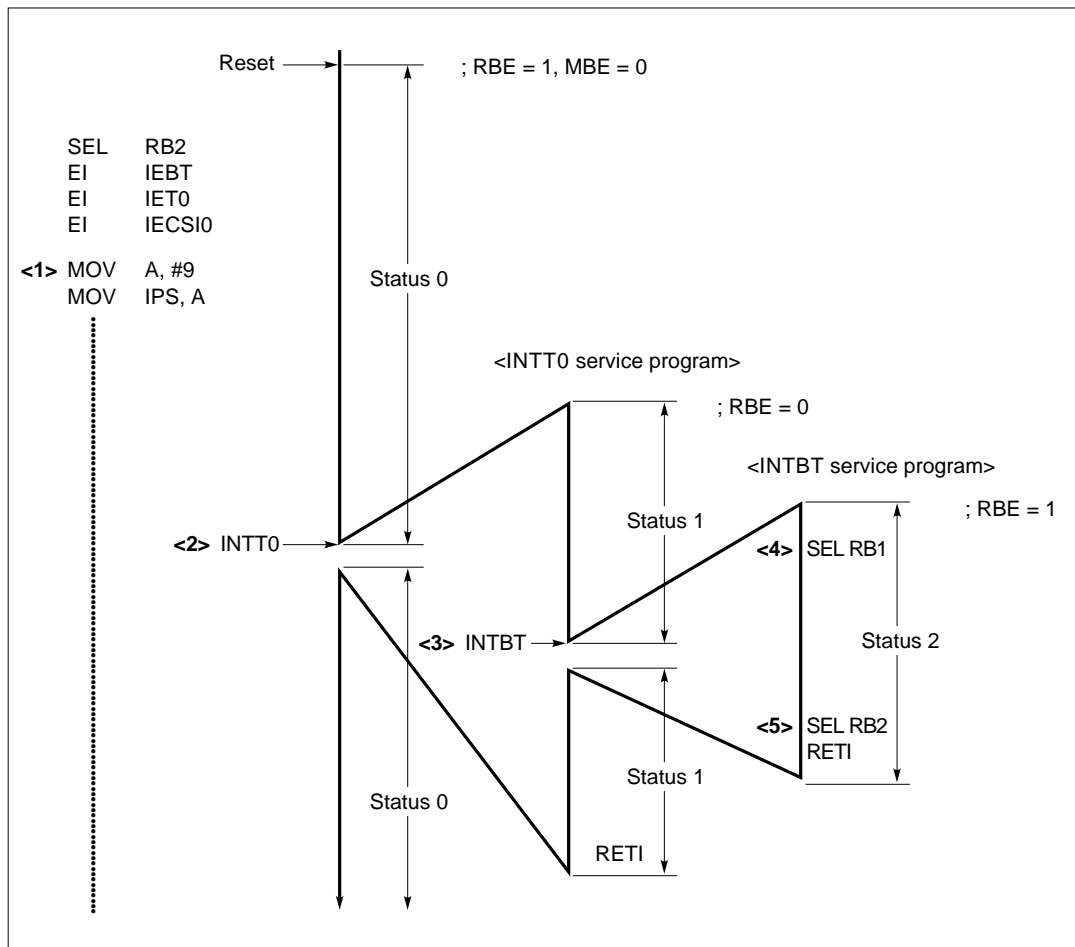

- <1> INTBT is given a higher priority by setting IPS, and the interrupt is enabled.
- <2> An occurrence of INTT0 with a lower priority causes the INTT0 interrupt service program to start and change to status 1, disabling interrupts with lower priorities. RBE = 0 is set, and register bank 0 is used.
- <3> An occurrence of INTBT with a higher priority causes two-level interrupt processing and change to status 2. All interrupts are disabled.
- <4> RBE = 1 and RBS = 1 are set, and register bank 1 is used. Only registers to be used may be saved by the PUSH instruction.
- <5> RBS is set to 2 and the return status is set to 1 again.

(4) Execution of held interrupts (interrupt requests when interrupts are disabled)

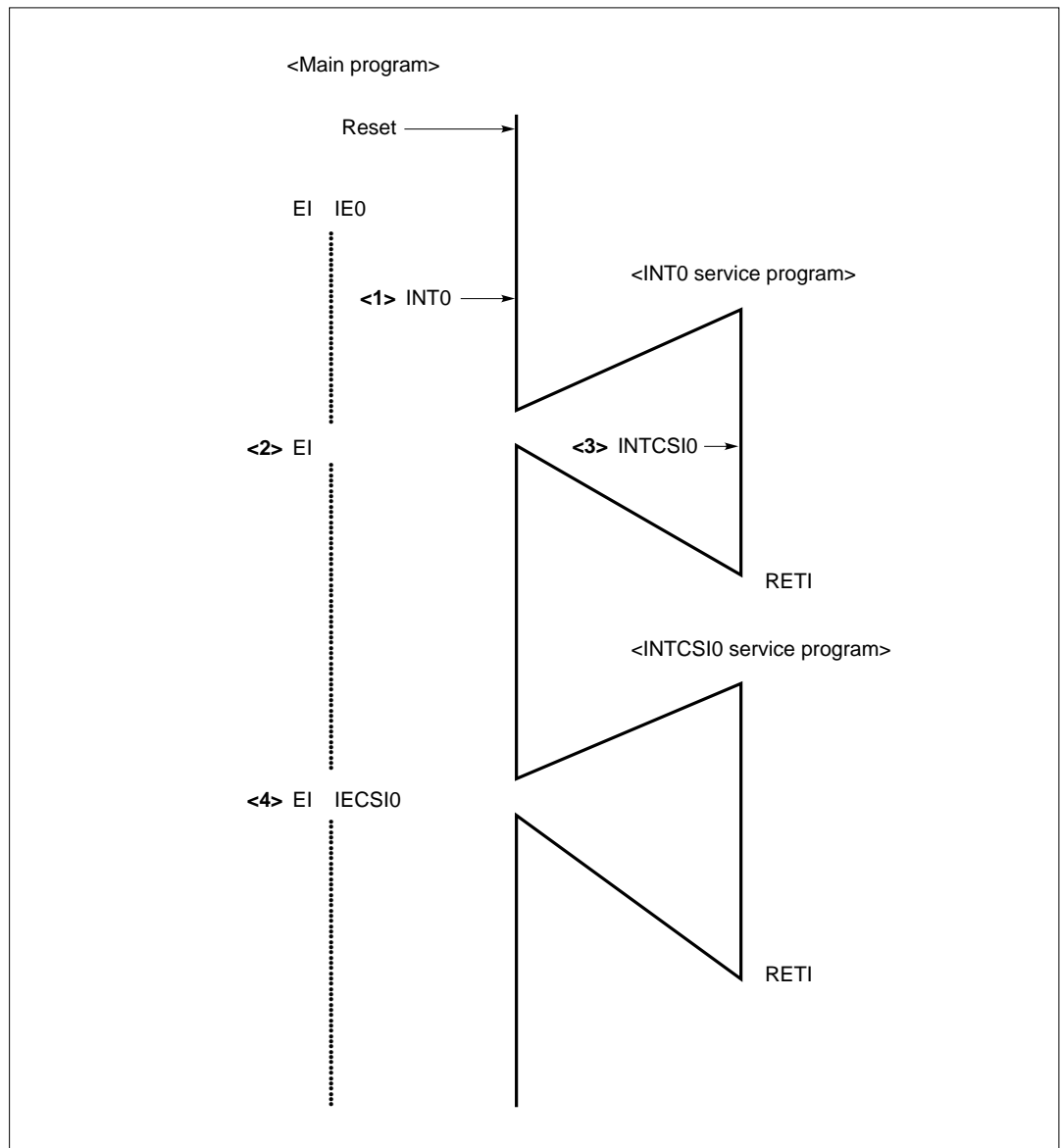

- <1> If INT0 is set when interrupts are disabled, the interrupt request flag is held.
- <2> When the interrupt is enabled by the EI instruction, the INT0 interrupt service program starts.
- <3> Same as <1>
- <4> When the held INTCS10 flag is enabled, the INTCS10 interrupt service program starts.

(5) Execution of held interrupts (when two low-order interrupts are requested concurrently)

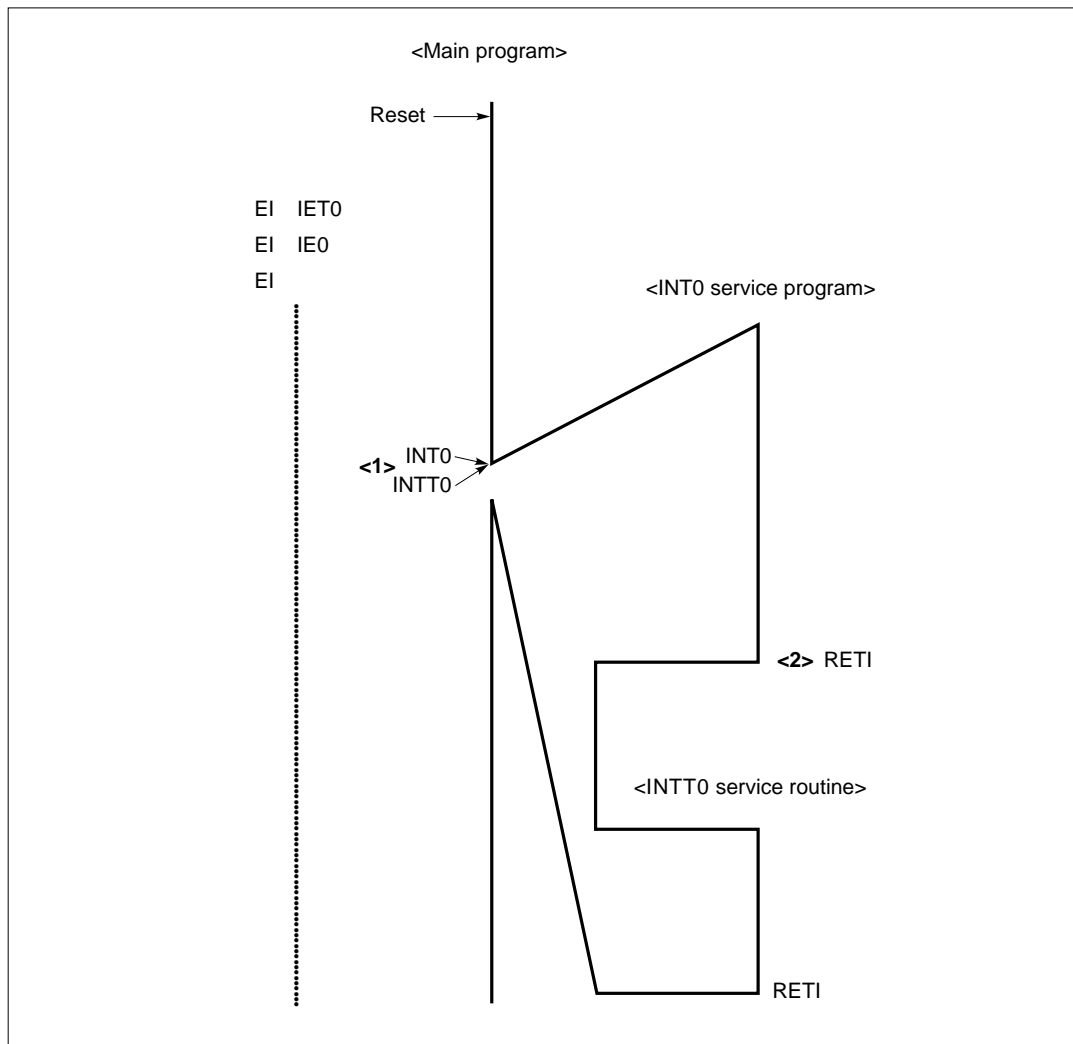

- <1> When low-order interrupts INT0 and INTT0 occur concurrently (during execution of the same instruction), INT0, with a higher priority, is executed first. (INTT0 is held.)
- <2> When the INT0 interrupt service program has been executed, the RETI instruction is executed to start the interrupt service program for INTT0, which has been held.

(6) Execution of held interrupts (when an interrupt request occurs during interrupt processing in the same condition as in (3) above)

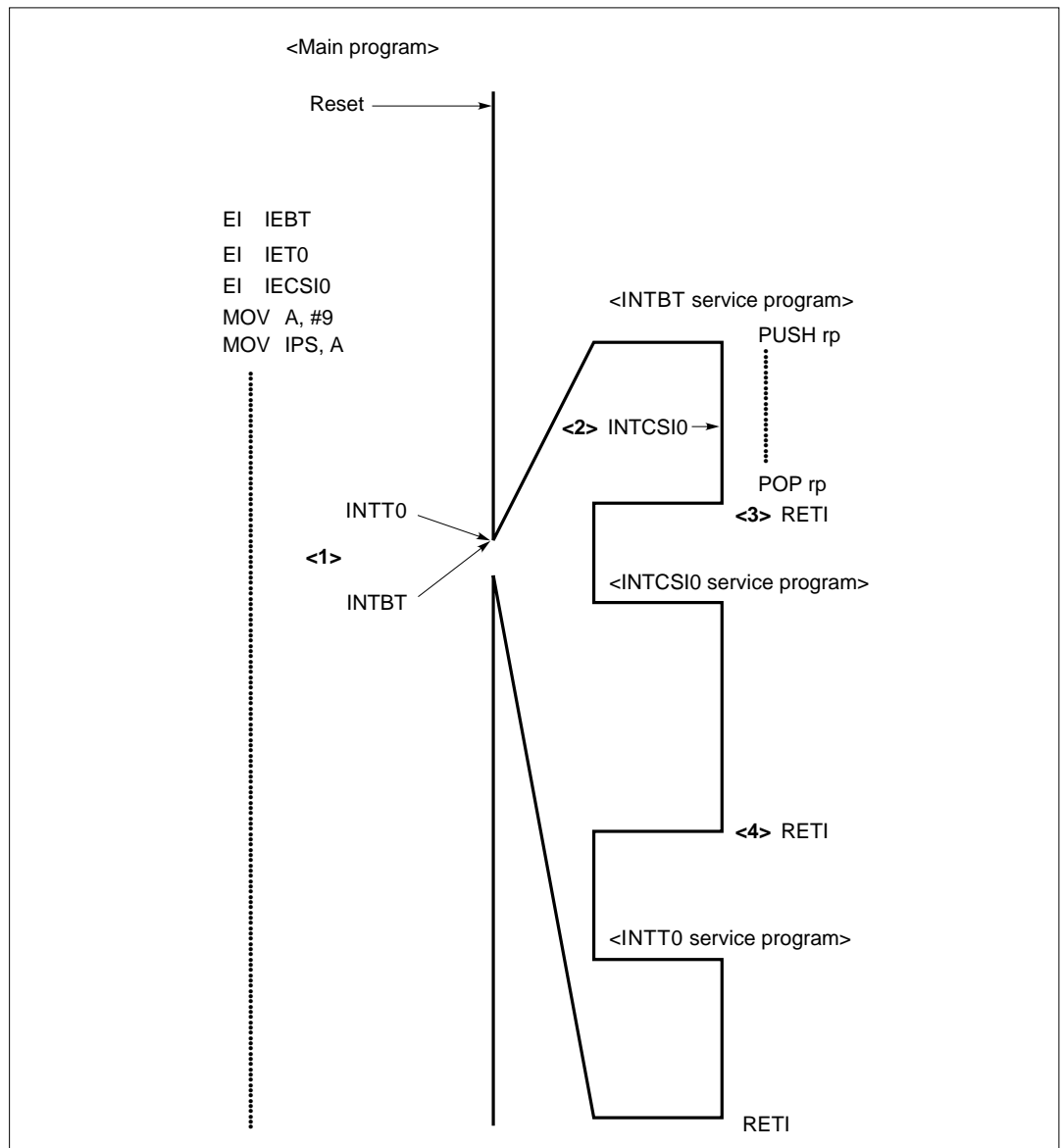

- <1> When requests for high-order interrupt INTBT and low-order interrupt INTT0 occur concurrently, INTBT is executed first. If it is highly unlikely that a high-order interrupt is requested during high-order interrupt processing, the DI IExx instruction need not be executed.
- <2> When a request for low-order interrupt INTCSI0 occurs during the high-order interrupt processing, INTCSI0 is held.
- <3> On completion of the high-order interrupt, INTCSI0 which is given a higher priority among the low-order interrupts being held is executed.
- <4> On completion of the INTCSI0 interrupt service program, INTT0 which has been held is executed.

(7) Enabling of level-two interrupts (enabling level-two INTT0 and INT0 interrupts with INTCSI0 and INT4 handled as level-one interrupts)

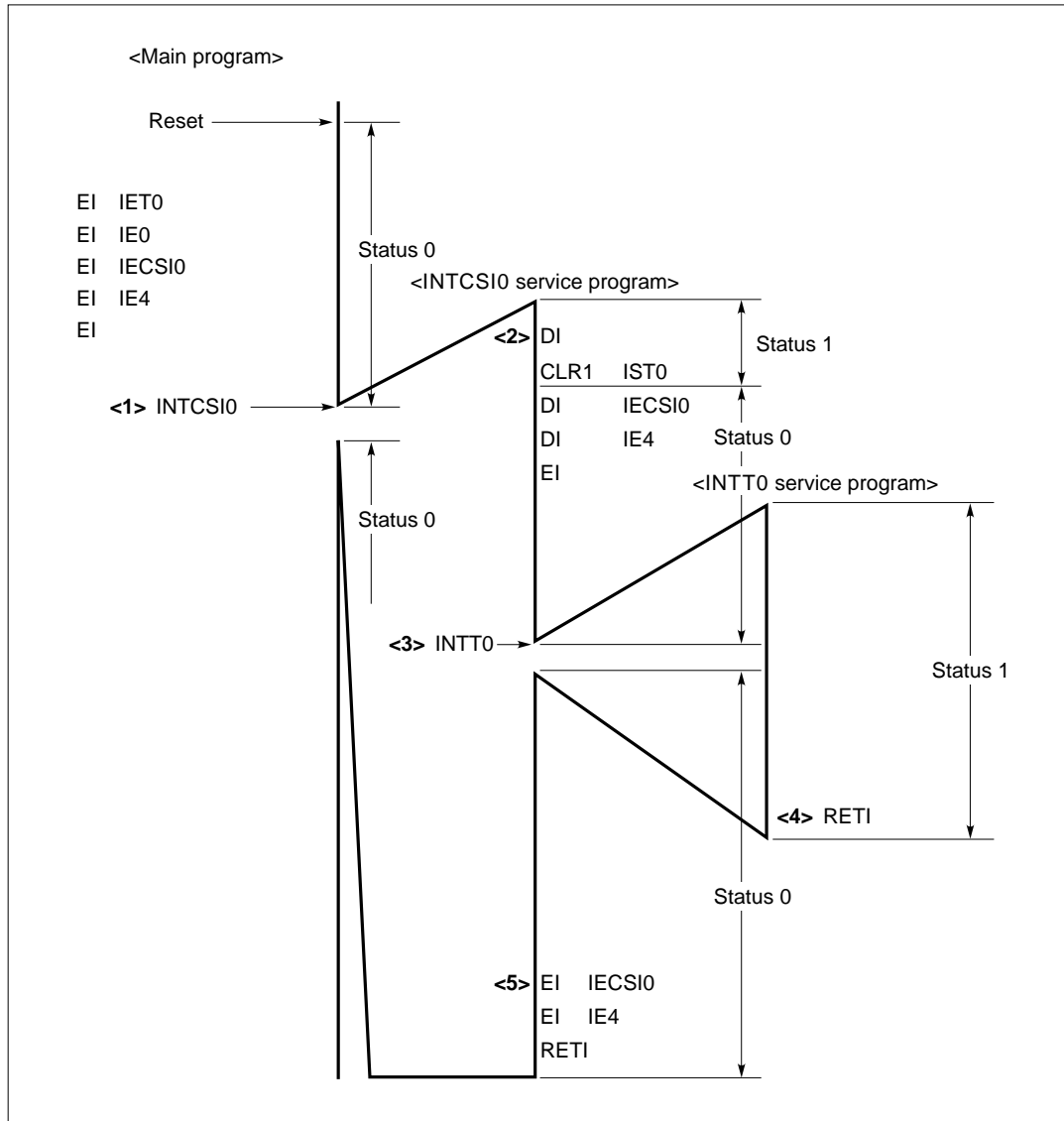

- <1> When an INTCSI0 interrupt not allowed to be a level-two interrupt occurs, the INTCSI0 service program starts, and status 1 is set.
- <2> Status 0 is set by clearing IST0. INTCSI0 and INT4 not allowed to be level-two interrupts are disabled.
- <3> When INTT0 allowed to be a level-two interrupt occurs, the level-two interrupt is executed, and status 1 is set to disable all interrupts.
- <4> When INTT0 processing is completed, status 0 is set again.
- <5> INTCSI0 and INT4 which have been disabled are enabled, then control returns.

Chapter 7

Standby Function

The μ PD75518 provides a standby function to reduce the power consumption by the system. The standby function is available in the two modes: the STOP mode and HALT mode.

Differences between these two modes are as follows:

(1) STOP mode

In the STOP mode, the main system clock oscillator is stopped, and the entire system stops. The current used by the CPU is reduced to quite a low level.

In addition, the contents of data memory can be preserved with a low supply voltage of down to $V_{DD} = 2\text{ V}$, that is, this mode is effective to retain data memory with a very low current.

The STOP mode of the μ PD75518 can be released by an interrupt request to enable intermittent operations. However, when the STOP mode is released, a wait time is needed for stable oscillation. Select the HALT mode when processing must be started immediately after an interrupt request.

(2) HALT mode

In the HALT mode, the CPU clock is stopped, but the oscillation of the system clock oscillator continues. In this mode, the system uses more current than in the STOP mode. However, the HALT mode is suitable for starting processing immediately after an interrupt request or for intermittent operations such as watch operation.

In either mode, all contents of the registers, flags, and data memory that are present immediately before the standby mode is set are preserved. In addition, the states of the output latches of the I/O ports and the states of the output buffers are also preserved, so that the states of the I/O ports are to be processed to minimize the power consumption of the entire system.

Cautions 1. The STOP mode can be used only for the main system clock. (Subsystem clock generation cannot be terminated.) The HALT mode can be used for either the main system clock or the subsystem clock.

-
- Cautions**
- 2. A lower power consumption and lower-voltage operation are enabled by switching standby modes or switching CPU and system clocks. However, a switching time as described in Section 5.2.3 is required before operation is started with a new clock after the clock is selected with the control register. For this reason, when the clock switching function is used together with a standby mode, the standby mode must be set after a time needed for switching elapses.**
 - 3. Configure I/O ports for minimum power consumption in the stand by mode. Be sure to connect signals which are high or low to input ports.**
-

7.1 Setting of Standby Modes and Operation Status

Table 7-1. Operation Statuses in the Standby Mode

		STOP mode	HALT mode
Instruction for setting		STOP instruction	HALT instruction
System clock at setting		Main system clock	Main system clock Subsystem clock
Operation status	Clock generator	Only the main system clock is stopped.	Only CPU clock Φ is stopped (with oscillation continued).
	Basic interval timer	Operation is stopped.	Operation is possible(Note). (IRQBT is set at reference time intervals).
	Serial interface (Channel 0)	Operation is possible only when external $\overline{SCK0}$ input is selected for the serial clock.	Operation is possible(Note).
	Serial interface (Channel 1)	Operation is possible only when external $\overline{SCK1}$ input is selected for the serial clock.	Operation is possible(Note).
	Timer/event counter	Operation is possible only when TI0 pin input is selected for the count clock.	Operation is possible(Note).
	Watch timer	Operation is possible only when f_{XT} is selected for the count clock.	Operation is possible.
	A/D converter	Operation is stopped.	Operation is possible(Note).
	Timer/pulse generator	Operation is stopped.	Operation is possible(Note).
	External interrupt	INT0 is disabled. INT1, INT2, and INT4 are enabled.	
	CPU	Operation is stopped.	
Release signal enabled		Interrupt request signals transmitted out from hardware, which are by interrupt enable flags, or \overline{RESET} input.	

(Note) Applicable only when the main system clock operates.

A STOP instruction is used to set the STOP mode, and a HALT instruction is used to set the HALT mode. (A STOP instruction sets bit 3 of PCC, and a HALT instruction sets bit 2 of PCC.)

STOP instruction or HALT instruction must always be followed by an NOP instruction.

When changing a CPU operation clock pulse with the low-order two bits of PCC, a time lag may occur from the time when PCC is rewritten to the time when the CPU clock signal is changed. When changing an operation clock pulse before the standby mode or a CPU clock signal after the standby mode is released, it is necessary to rewrite PCC and set the standby mode after as many machine cycles as required to change the CPU clock pulse have elapsed.

In a standby mode, the contents of all registers and data memory that are stopped during the standby mode, including general registers, flags, mode registers, and output latches, are retained.

Cautions 1. When the STOP mode is set, the X1 input is internally connected to V_{SS} (ground potential) to suppress leakage at the crystal oscillator circuitry. This means that the STOP mode cannot be used with a system that uses an external clock as the main system clock.

2. Reset all the interrupt request flags before setting the standby mode.

If an interrupt source whose interrupt request flag and interrupt enable flag are both set exists, the initiated standby mode is released immediately after it is set (see Figure 6-1). When the STOP mode is set, however, the μ PD75518 enters the HALT mode immediately after the STOP instruction is executed, then returns to the operation mode after the wait time specified by the BTM register has elapsed.

7.2 Release of the Standby Modes

The STOP mode and HALT mode are released by a $\overline{\text{RESET}}$ signal or the generation of an interrupt request signal (Note) that is enabled with the interrupt enable flag. Figure 7-1 shows how the STOP and HALT modes are released.

(Note) INT0 is excluded.

Figure 7-1. Standby Mode Release Operation (1/2)

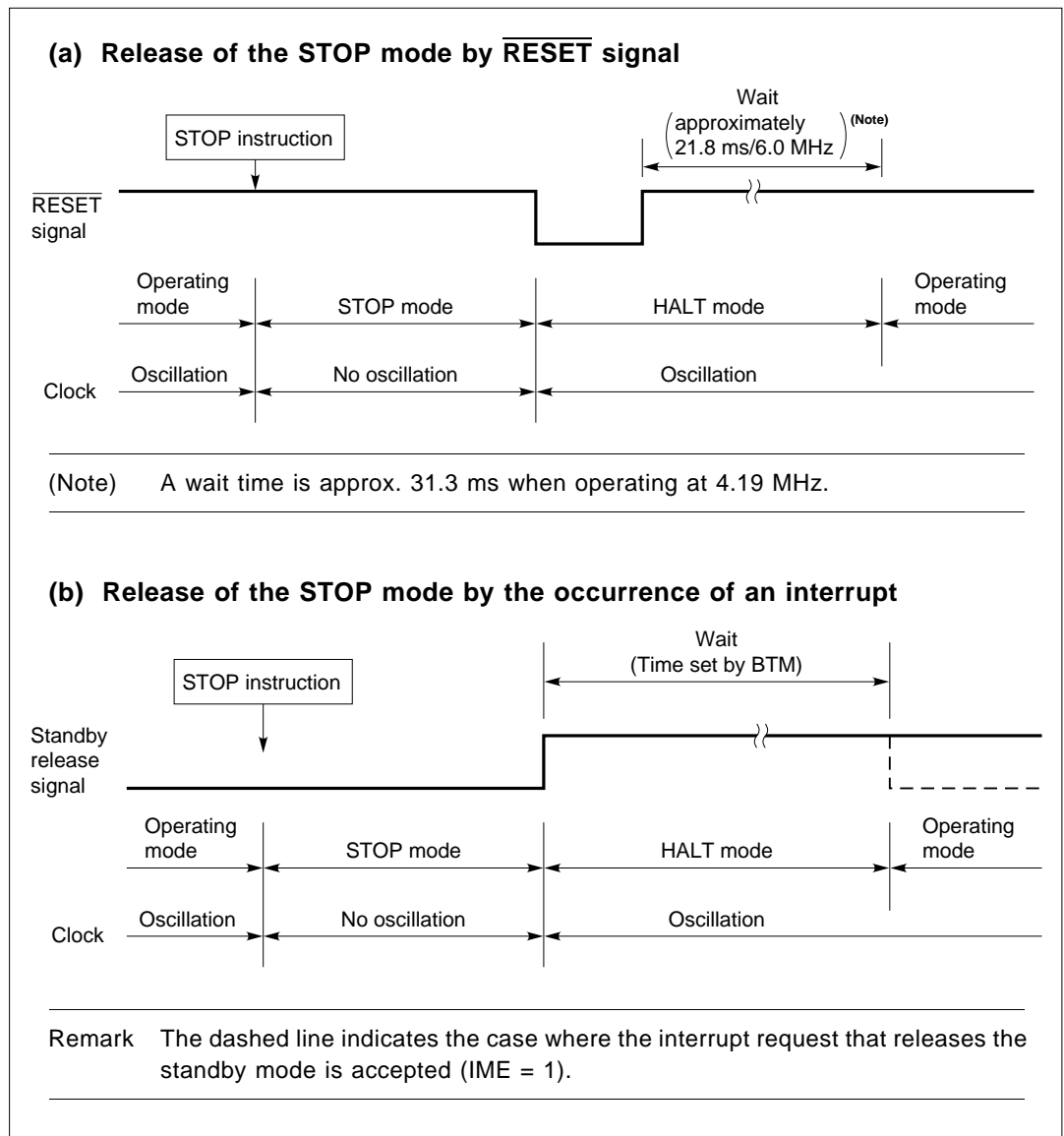
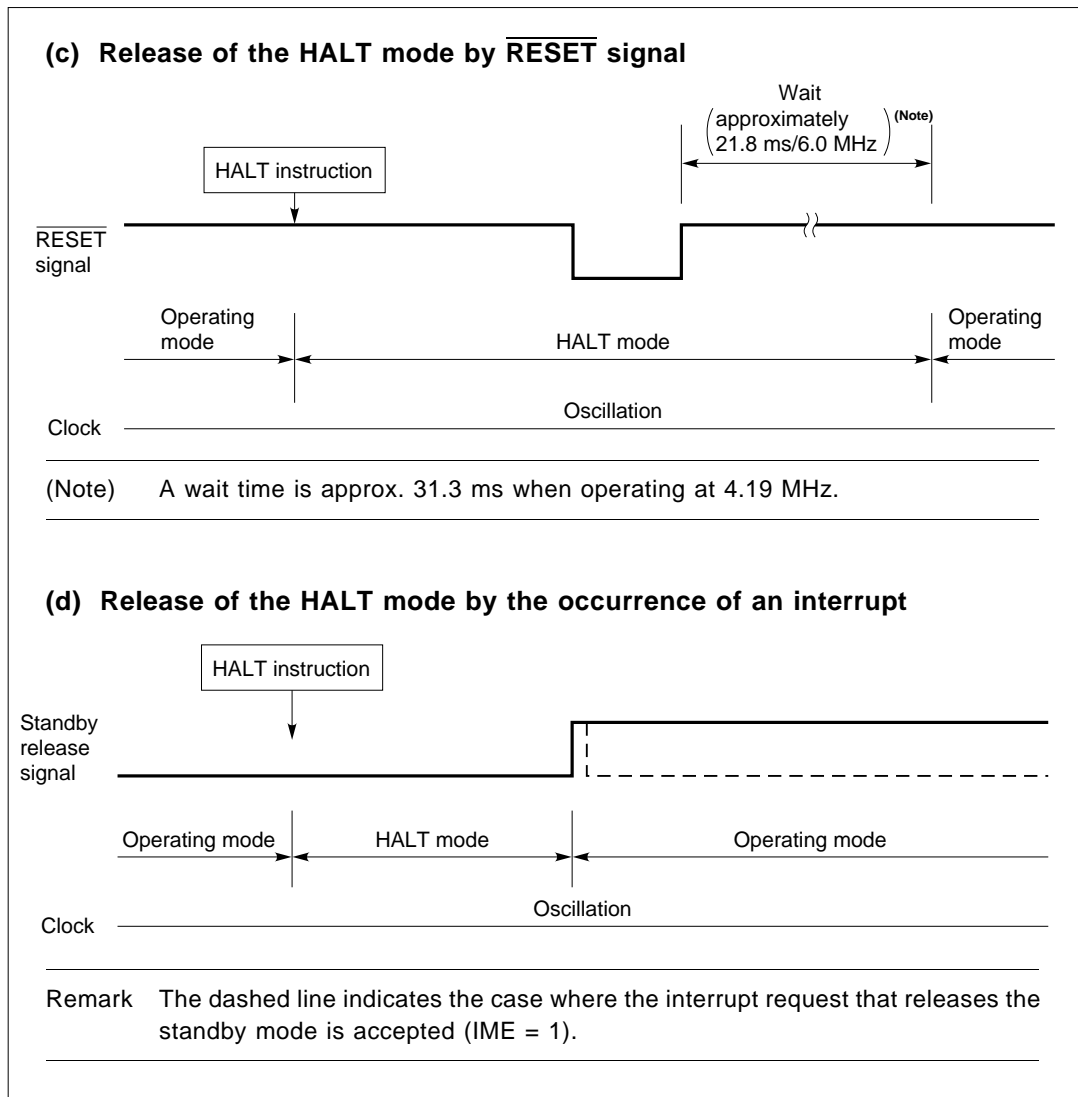

Figure 7-1. Standby Mode Release Operation (2/2)



When the STOP mode is released by the occurrence of an interrupt, a wait time is determined by the basic interval timer mode register (BTM). (See **Table 7-2.**)

A time required for stable oscillation varies with the type of resonator used and the supply voltage at the time of STOP mode release. Accordingly, a wait time is to be selected according to each application, and BTM is to be set before the STOP mode is set.

*

In particular, because the oscillation settling time of the crystal is longer than that of the ceramic resonator, set a longer wait time.

Table 7-2. Selection of a Wait Time with BTM

(When $f_X = 6.0$ MHz)

BTM3	BTM2	BTM1	BTM0	Wait time(Notes). () indicates the value for $f_X = 6.0$ MHz
—	0	0	0	Approx. $2^{20}/f_X$ (Approx. 175 ms)
—	0	1	1	Approx. $2^{17}/f_X$ (Approx. 21.8 ms)
—	1	0	1	Approx. $2^{15}/f_X$ (Approx. 5.46 ms)
—	1	1	1	Approx. $2^{13}/f_X$ (Approx. 1.37 ms)
Other than above				Use prohibited

(When $f_X = 4.19$ MHz)

BTM3	BTM2	BTM1	BTM0	Wait time(Notes). () indicates the value for $f_X = 4.19$ MHz
—	0	0	0	Approx. $2^{20}/f_X$ (Approx. 250 ms)
—	0	1	1	Approx. $2^{17}/f_X$ (Approx. 31.3 ms)
—	1	0	1	Approx. $2^{15}/f_X$ (Approx. 7.82 ms)
—	1	1	1	Approx. $2^{13}/f_X$ (Approx. 1.95 ms)
Other than above				Use prohibited

(Note) This time does not include the time from the release of the STOP mode to the start of oscillation.

Cautions 1. The wait times used when the STOP mode is released do not include the time (a in the figure below) required before clock oscillation is started following the release of the STOP mode, regardless of whether the STOP mode is released by a $\overline{\text{RESET}}$ signal or the generation of an interrupt.

2. Since the frequency has yet to settle at the start of oscillation, if noise having a frequency higher than that being used is input, that noise may function as a clock. In this case, the wait time may be shorter than the initially set time. Set a longer interval until oscillation starts. *

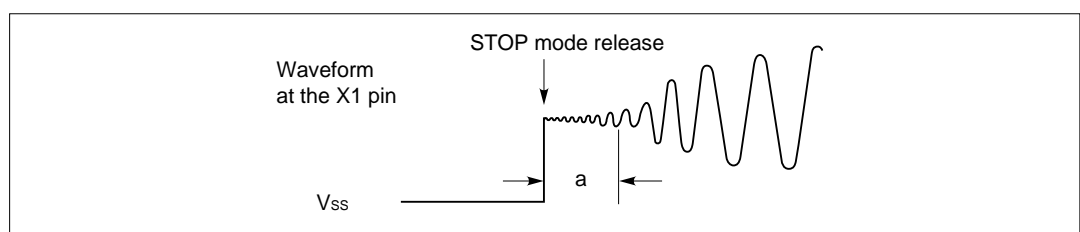

7.3 Operation after a Standby Mode Is Released

- (1) If a standby mode is released by a $\overline{\text{RESET}}$ signal, normal reset operation is performed.
- (2) If a standby mode is released by the occurrence of an interrupt request, the contents of the interrupt master enable flag (IME) determines whether to perform a vectored interrupt when the CPU resumes instruction execution.

(a) When IME = 0

If a standby mode is released, execution restarts with the instruction (NOP instruction) immediately following the instruction used to set the standby mode.

The interrupt request flag is held.

(b) When IME = 1

If a standby mode is released, a vectored interrupt is executed after the two instructions following the instruction used to set the standby mode are executed.

However, if the standby mode is released by INT2 or INTW (input of a test signal), no vectored interrupt occurs, and the same processing as (a) above is performed.

7.4 Applications of the Standby Modes

When the standby modes are used, the following steps are used.

- <1> Detect a standby mode setting factor such as power removal on an interrupt input or port input. (INT4 is useful for power removal detection.)
- <2> Configure I/O ports for minimum power consumption Be sure to connect signals which are high or low to input ports.
- <3> Specify interrupts for releasing a standby mode. (INT4 is useful. All interrupt enable flags not used for release are to be cleared.)
- <4> Specify an operation to be performed after release. (IME is to be manipulated according to whether interrupt processing is performed or not.)
- <5> Specify a CPU clock to be used after release. (If the CPU clock is changed, required machine cycles must elapse before the standby mode is set.)
- <6> Select a wait time to be used when a standby mode is released.
- <7> Set a standby mode using a STOP or HALT instruction.

A standby mode when combined with the system clock switch function enables a lower power consumption and lower-voltage operation.

(1) Application of the STOP mode (at $f_x = 4.19$ MHz)

<Use of the STOP mode under the following conditions>

- The STOP mode is set on the falling edge of INT4, and is released on the rising edge of INT4. (INTBT is not used.)
- All I/O ports have a high impedance (when ports are externally configured for minimum power consumption at high impedance).
- The INT0 and INTT0 interrupts are used for the program, but are not used to release the STOP mode.
- After the STOP mode is released, interrupts are enabled.
- After the STOP mode is released, the lowest-speed CPU clock is used for operation.
- A wait time used when the STOP mode is released is about 31.3 ms.
- After the STOP mode is released, another wait time of 31.3 ms is used for stable power supply operation. The P00/INT4 pin is checked twice to remove chattering.

<Timing chart>

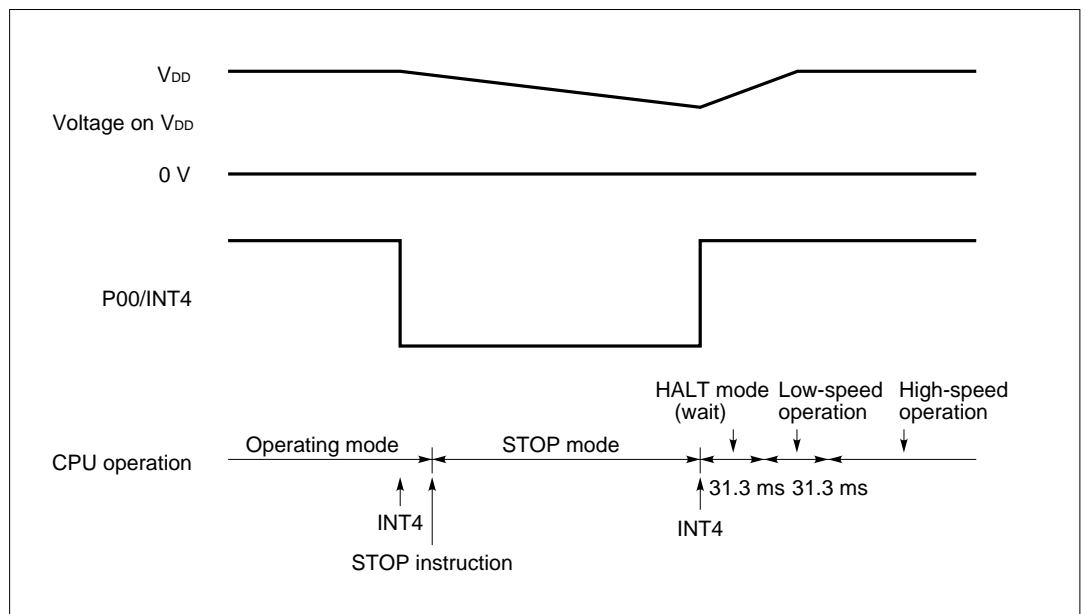

*

```
<Sample program> (INT4 service program, MBE = 0)
VSUB4      : SKT      PORT0.0      ; P00 = 1?
            BR        PDOWN        ; Power-down
            SET1     BTM.3         ; Power-on
WAIT       : SKT      IRQBT        ; Wait for 31.3 ms.
            BR        WAIT
            SKT      PORT0.0      ; Chattering check
            BR        PDOWN
            MOV      A,#0011B
            MOV      PCC,A        ; Set high-speed mode.
            [ MOV    XA,#xxH      ] ; Set port mode register.
            [ MOV    PMGm,XA     ]
            EI       IE0
            EI       IET0
            RETI
PDOWN     : MOV      A,#0          ; Lowest-speed mode
            MOV      PCC,A
            MOV      XA,#00H
            MOV      PMGA,XA      ; I/O port high impedance
            MOV      PMGB,XA
            MOV      PMGC,XA
            DI       IE0          ; Disable INT0 and INTT0
            DI       IET0
            MOV      A,#1011B
            MOV      BTM,A        ; Wait time = 31.3 ms
            NOP
            STOP      ; Set STOP mode.
            NOP
            RETI
```

(2) Application of the HALT mode (at $f_X = 4.19$ MHz, $f_{XT} = 32.768$ kHz)

<Intermittent operation under the following conditions>

- The standby mode is set on the falling edge of INT4, and is released on the rising edge of INT4.
- In the standby mode, intermittent operation is performed at intervals of 250 ms (INTBT).
- INT4 and INTBT are low-order interrupts.
- The lowest-speed CPU clock is used for operation in the standby mode.

<Timing chart>

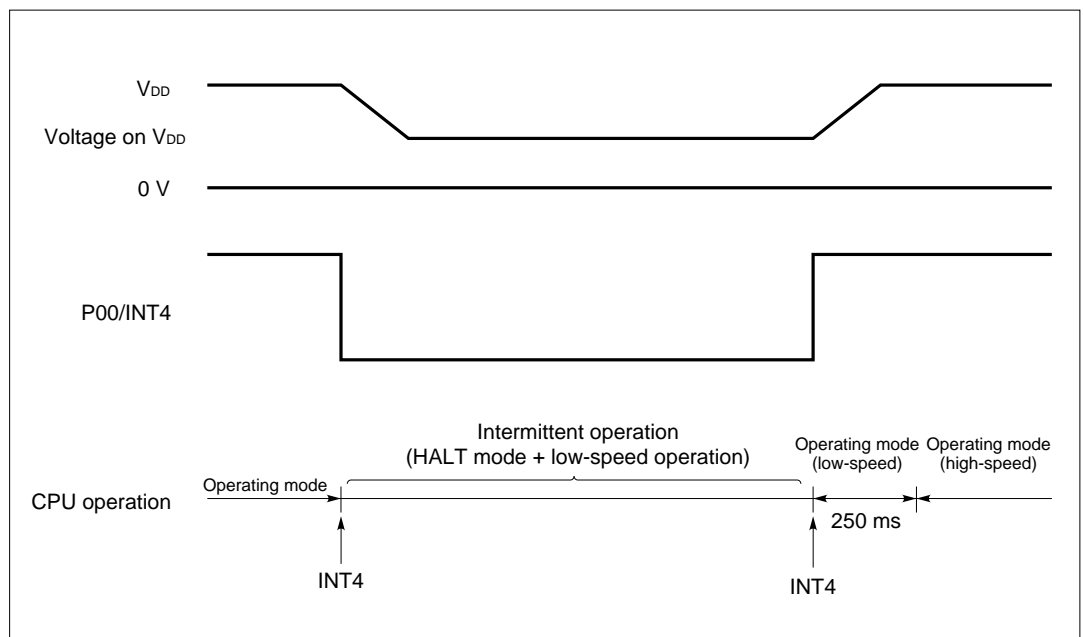

<Sample program> (INTBT/INT4 service program, MBE = 0)

```

BTAND4   : SKTCLR  IRQ4           ; INT4 = 1?
          BR      VSUBBT         ; NO
          SKT     PORT0.0        ; P00 = 1?
          BR      PDOWN          ; Power-down
          SETI    BTM.3           ; Start BT.
WAIT     : SKT     IRQBT         ; Wait for 250 ms.
          BR      WAIT
          SKT     PORT0.0
          BR      PDOWN
          MOV     A,#0011B       ; High-speed mode
          MOV     PCC,A
          [EI    IEn]           ; IEn <- 1
          RETI
PDOWN    : MOV     A,#0           ; Lowest-speed mode
          MOV     PCC,A          ]
          [DI    IEn]           ; IEn <- 0
          .....
          .....                Reserve 46 machine cycles(Note).
          .....
SETHLT   : HALT                    ; HALT mode
          NOP
          RETI
VSUBBT   : CLR1    IRQBT          ]
          .....
          .....                Processing at intermittent operation
          BR      SETHLT
    
```

* (Note) See **Section 5.2.3** for switching between the system clock and CPU clock.

* **Caution** Before the system clock is changed from the main system clock to the subsystem clock, a wait time sufficient for stable subsystem clock generation is required.

Chapter 8

Reset Function

The μ PD75518 is reset by a $\overline{\text{RESET}}$ signal. When reset, the hardware is initialized as indicated in Table 8-1. Figure 8-1 shows the timing of reset operation.

Figure 8-1. Reset Operation by a $\overline{\text{RESET}}$ signal

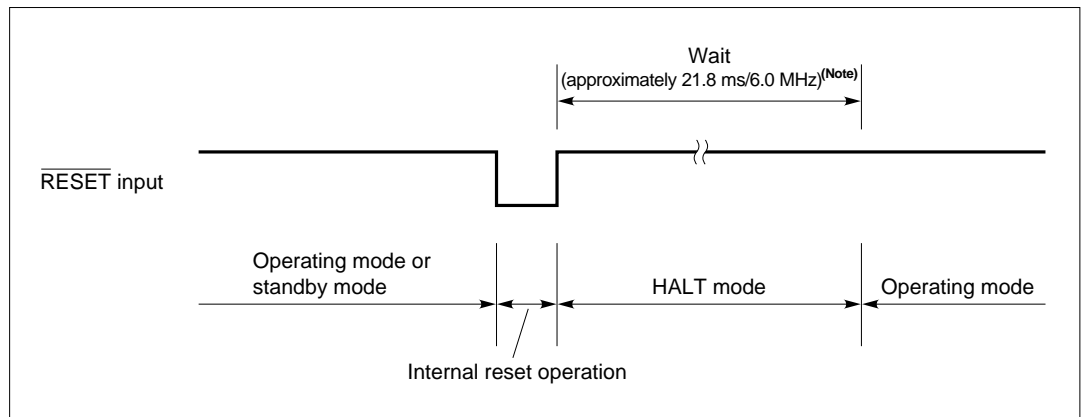

(Note) A wait time is approx. 31.3 ms when operating at 4.19 MHz.

Table 8-1. Statuses of the Hardware after a Reset (1/2)

Hardware		RESET signal in a standby mode	RESET signal during operation
Program counter (PC)		Low-order 6 bits a address 0000H in program memory are set in PC13-8, and the data at address 0001H are set in PC7-0.	Low-order 6 bits at address 0000H in program memory are set in PC13-8, and the data at address 0001H are set in PC7-0.
PSW	Carry flag (CY)	Held	Undefined
	Skip flags (SK0 to SK2)	0	0
	Interrupt status flags (IST0, IST1)	0	0
	Bank enable flags (MBE, RBE)	Bit 6 at address 0000H in program memory is set in RBE, and bit 7 is set in MBE.	Bit 6 at address 0000H in program memory is set in RBE, and bit 7 is set in MBE.
Data memory (RAM)		Held(Note)	Undefined
General registers (X, A, H, L, D, E, B, C)		Held	Undefined
Bank select registers (MBS, RBS)		0, 0	0, 0
Stack pointer (SP)		Undefined	Undefined
Stack bank select register (SBS)		Undefined	Undefined
Basic interval timer	Counter (BT)	Undefined	Undefined
	Mode register (BTM)	0	0
Timer/event counter	Counter (T0)	0	0
	Modulo register (TMOD0)	FFH	FFH
	Mode register (TM0)	0	0
	TOE0, TOUT flip-flop	0, 0	0, 0
Timer/pulse generator	Modulo registers (MODH, MODL)	Held	Held
	Mode register (TPGM)	0	0
Clock timer	Mode register (WM)	0	0

(Note) A RESET signal causes data at addresses 08FH-0FDH in data memory to be undefined.

Table 8-1. Statuses of the Hardware after a Reset (2/2)

Hardware		RESET signal in a standby mode	RESET signal during operation	
Serial interface (Channel 0)	Shift register 0 (SIO0)	Held	Undefined	
	Operation mode register 0 (CSIM0)	0	0	
	SBI control register (SBIC)	0	0	
	Slave address register (SVA)	Held	Undefined	
	P01/SCK0 output latch	1	1	
Serial interface (Channel 1)	Shift register (SIO1)	Held	Undefined	
	Operation mode register 1 (CSIM1)	0	0	
	Serial transfer end flag (EOT)	0	0	
A/D converter	Mode register (ADM), EOC	04H (EOC = 1)	04H (EOC = 1)	
	SA register	Undefined	Undefined	
Clock generator, clock output circuit	Processor clock control register (PCC)	0	0	
	System clock control register (SCC)	0	0	
	Clock output mode register (CLOM)	0	0	
Interrupt	Interrupt request flag (IRQxxx)	IRQ1, IRQ2, IRQ4	Undefined	*
		Other than above	0	
	Interrupt enable flag (IExxx)	0	0	
	Interrupt master enable flag (IME)	0	0	
	INT0, INT1 and INT2 mode registers (IM0, IM1, IM2)	0, 0, 0	0, 0, 0	
Digital ports	Output buffer	Off	Off	
	Output latch	Clear (0)	Clear (0)	
	I/O mode registers (PMGA, PMGB, PMGC)	0	0	
	Pull-up resistor specification register (POGA)	0	0	
Bit sequential buffers (BSB0 to BSB3)		Held	Undefined	

[MEMO]

Chapter 9

Writing to and Verifying Program Memory (PROM)

The program memory in the μ PD75P518 consists of a one-time PROM, which can be written into only once, or consists of an EPROM, which can be erased and reprogrammed. The memory capacity is as follows:

μ PD75P518: 32640 words x 8 bits

Writing to and verifying the contents of the one-time PROM is accomplished by using the pins shown in Table 9-1. Note that address inputs are not used; instead, the address is updated using the clock input from the X1 pin.

Table 9-1. Pin Functions

Pin name	Function
X1, X2	Address update clock inputs used when writing to the program memory or verifying its contents. The X2 pin is used to input the inverted signal of the X1 pin input.
MD0-MD3 (P30 to P33)	Operation mode selection pins used when writing to the program memory or verifying its contents.
P40 to P43 (low-order four bits) P50 to P53 (high-order four bits)	I/O pins for 8-bit data used when writing to the program memory or verifying its contents.
V _{DD}	Power voltage is applied to this pin. During normal operation, 2.7 to 6.0 V should be applied; +6 V should be applied when writing to the program memory or verifying its contents.
V _{PP}	Voltage is applied to this pin when writing to the program memory or verifying its contents (normally V _{DD} electric potential).

Cautions 1. Pins not to be used for writing into or verifying the program memory are handled as follows.

Pins other than XT2: Connected to the V_{SS} via the pull-down resistor

XT2: Open

-
- Cautions**
- 2.** For the μ PD75P518K, which has an erasure window, a cover film must be put on the window to shield the light except when the contents of the EPROM are to be erased.
 - 3.** The μ PD75P518GF with a one-time PROM does not have an erasure window, so the contents of the program memory can not be erased with ultraviolet radiation.
-

9.1 Operating Modes when Writing to and Verifying the Program Memory

If +6 V is applied to the V_{DD} pin and +12.5 V is applied to the V_{PP} pin, the μ PD75P518 enters program memory write/verify mode. The specific operating mode is then selected by inputting signals to the MD0 through MD3 pins as listed in Table 9-2.

Table 9-2. Operating Modes

Operating mode specification						Operating mode
V_{DD}	V_{PP}	MD0	MD1	MD2	MD3	
+6 V	+12.5 V	H	L	H	L	Program memory address clear mode
		L	H	H	H	Write mode
		L	L	H	H	Verify mode
		H	X	H	H	Program inhibit mode

Remark X indicates L or H.

9.2 Writing to the Program Memory

The procedure for writing to program memory is described below; high-speed write is possible.

- (1) Pull low all unused pins to V_{SS} by means of resistors.
Bring X1 to low level.
- (2) Apply 5 V to V_{DD} and to V_{PP} .
- (3) Wait 10 μ s.
- (4) Select program memory address clear mode.
- (5) Apply +6 V to V_{DD} and +12.5 V to V_{PP} .
- (6) Select program inhibit mode.
- (7) Select write mode for 1 ms duration and write data.
- (8) Select program inhibit mode.
- (9) Select verify mode. If write is successful, proceed to step (10). If write fails, repeat steps (7) to (9).
- (10) Perform additional write for (Number of repetitions of steps (7) to (9)) x 1 ms duration.
- (11) Select program inhibit mode.
- (12) Increment the program memory address by inputting four pulses on the X1 pin.
- (13) Repeat steps 7 to 12 until the last address is reached.
- (14) Select program memory address clear mode.
- (15) Apply 5 V to V_{DD} and to V_{PP} .
- (16) Turn the power off.

The timing for steps (2) to (12) is shown below.

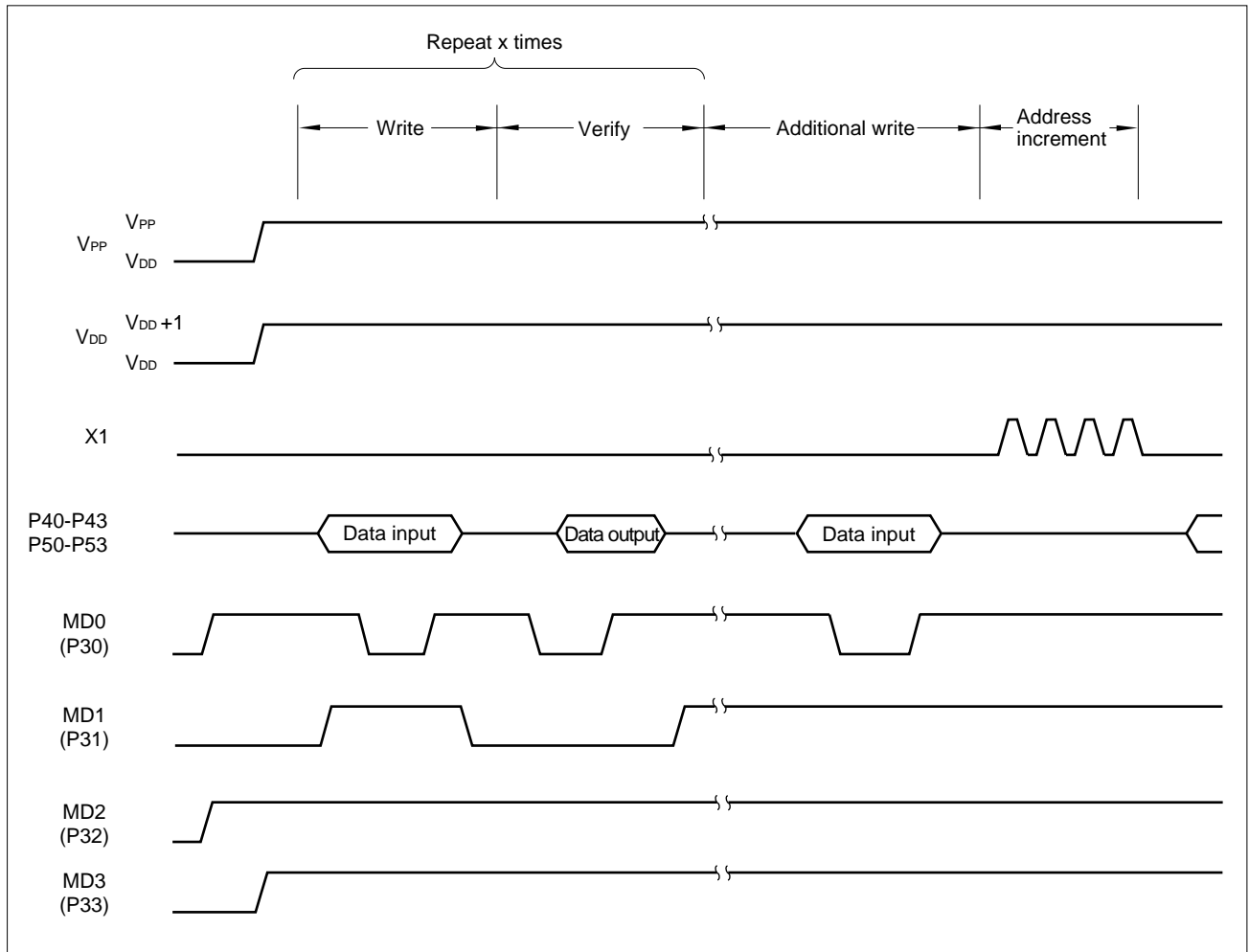

9.3 Reading the Program Memory

The procedure for reading the contents of program memory is described below. The read is performed in the verify mode.

- (1) Pull low all unused pins to V_{SS} by means of resistors.
Bring X1 to low level.
- (2) Apply 5 V to V_{DD} and V_{PP} .
- (3) Wait 10 μ s.
- (4) Select program memory address clear mode.
- (5) Apply +6 V to V_{DD} and +12.5 V to V_{PP} .
- (6) Select program inhibit mode.
- (7) Select verify mode. Data is output sequentially one address at a time for each cycle of four clock pulses appearing on the X1 pin.
- (8) Select program inhibit mode.
- (9) Select program memory address clear mode.
- (10) Apply 5 V to V_{DD} and to V_{PP} .
- (11) Turn the power off.

The timing for steps (2) to (9) is shown below.

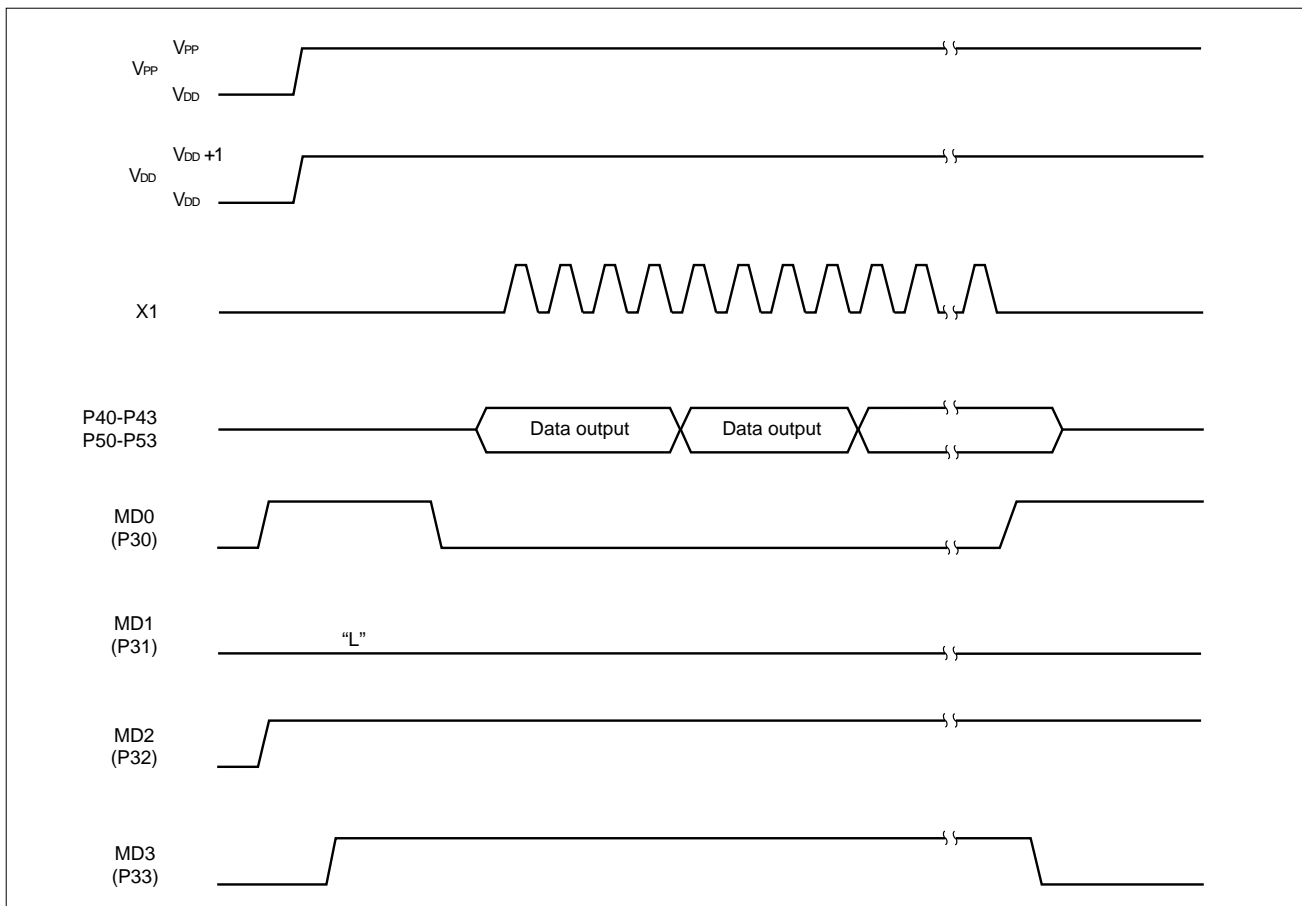

9.4 Erasing the Program Memory (for the μ PD75P518K Only)

The contents of data written into the μ PD75P518K can be erased by exposing the window to ultraviolet radiation.

The wavelength of ultraviolet must be at least 250 nm. To erase data completely, the exposure must be 15 Ws/cm² (ultraviolet intensity x erasure time).

When a commercial ultraviolet lamp (wavelength of 254 nm, intensity of 12 mW/cm²) is used, it takes 15 to 20 minutes to complete erasure.

-
- Cautions**
- 1. Exposing the window to direct sunlight or fluorescent light for a long time may cause erasure of data. To protect data, the upper window must be masked with a shielding cover film. Shielding cover films are attached to UV EPROM products of NEC.**
 - 2. For normal erasure operation, the ultraviolet lamp must be set not more than 2.5 cm apart from the μ PD75P518K.**
-

Remark Degradation of the ultraviolet lamp or stains on the package window may cause an erasure operation to take a longer time.

9.5 Screening One-Time PROM Products

*

NEC cannot execute a complete test of one-time PROM product (μ PD78P518GF) due to their structure before shipment. It is recommended that you screen (verify) PROM products after writing necessary data into them and storing them at 125 °C for 24 hours.

NEC offers a charged service called QTOP microcomputer service. This service includes writing to one-time PROM, marking, screening, and verification. Ask your sales representative for details.

[MEMO]

Chapter 10

Instruction Set

The instruction set of the μ PD75518 is an improved and extended version of the instruction set used with the μ PD7500 series, which is the predecessor of the 75X series. Succeeding the instruction set of the μ PD7500 series, the μ PD75518 has quite a new, enhanced instruction set with the following features:

- (1) Bit manipulation instructions allowing a wide variety of applications
- (2) Efficient 4-bit manipulation instructions
- (3) Eight-bit data transfer instructions
- (4) GETI instruction for reducing program sizes
- (5) String effect instructions and number system conversion instructions for increased program efficiency
- (6) Table reference instructions suitable for successive references
- (7) 1-byte relative branch instructions
- (8) NEC standard mnemonics designed for clarity and readability

See **Chapter 3** for the addressing modes applicable to data memory manipulation.

10.1 Unique Instructions

This section outlines the unique instructions among the μ PD75518 instruction set.

10.1.1 GETI Instruction

The GETI instruction converts any of the following instructions to a 1-byte instruction:

- (a) Subroutine call instruction for the entire space
- (b) Branch instruction for the entire space
- (c) Arbitrary 2-byte instruction operating with two machine cycles (Except the BRCB and CALLF instructions)
- (d) A combination of two 1-byte instructions

The GETI instruction references the table located at addresses 0020H to 007FH in program memory, and executes referenced 2-byte data as an instruction of (a), (b), (c), or (d) above. This means that 48 instructions consisting of (a) to (d) can be converted to 1-byte instructions.

Thus the GETI instruction can be used to convert frequently used instructions of (a) to (d) to 1-byte instructions to reduce the number of program bytes significantly.

-
- Cautions 1. A 2-byte instruction which can be referenced by a GETI instruction must be a two-machine-cycle instruction. (Except the BRCB and CALLF instructions)**
- 2. When referencing two 1-byte instructions with a GETI instruction, only the combinations listed in the table below are valid.**
-

First byte instruction	Second byte instruction
MOV A,@HL	[INCS L DECS L
MOV @HL,A	[INCS H DECS H
XCH A,@HL	INCS HL
MOV A,@DE	[INCS E DECS E
XCH A,@DE	[INCS D DECS D INCS DE
MOV A,@DL	[INCS L DECS L
XCH A,@DL	[INCS D DECS D

Cautions 3. Branch and subroutine instructions can be referenced by the GETI instruction only when their destination addresses are in the 16K-byte space (0000H to 3FFFH). A branch or subroutine instruction to an address from 4000H to 5F7FH or 4000H to 7F7FH(Note) cannot be referenced by the GETI instruction.

(Note) 4000H to 5F7FH: μ PD75517
4000H to 7F7FH: μ PD75518 and μ PD75P518

Since the PC is not incremented during execution of a GETI instruction, control returns to the address next to the GETI instruction after the execution of the GETI instruction.

When the instruction before a GETI instruction has the skip function, the GETI instruction is skipped in the same way as for other 1-byte instructions. When the instruction referenced by a GETI instruction has the skip function, the instructions after the GETI instruction are skipped.

When a string effect instruction is referenced by a GETI instruction, the following results are obtained.

- When the group of the string effect instruction before the GETI instruction is the same as that of the instruction referenced by the GETI instruction, the effect of the string effect instruction is canceled and the referenced instruction is not skipped.
- When the group of the instruction after the GETI instruction is the same as that of the instruction referenced by the GETI instruction, the effect of the string effect instruction caused by the referenced instruction is valid and the instructions after the referenced instruction are skipped.

10.1.2 Bit Manipulation Instructions

With the μ PD75518, a variety of instructions are available for bit manipulation.

- (a) Bit setting : SET1 mem.bit
SET1 mem.bit*
- (b) Bit clearing : CLR1 mem.bit
CLR1 mem.bit*
- (c) Bit testing : SKT mem.bit
SKT mem.bit*
- (d) Bit testing : SKF mem.bit
SKF mem.bit*
- (e) Bit testing and clearing : SKTCLR mem.bit*
- (f) Boolean operation : AND1 CY,mem.bit*
OR1 CY,mem.bit*
XOR1 CY,mem.bit*
- (g) Bit transfer : MOV1 CY,mem.bit*
MOV1 mem.bit*,CY

mem.bit* represents a bit address addressed by using a bit manipulation addressing mode (fmem.bit, pmem.@L, or @H+mem.bit).

Particularly, all of these bit manipulation instructions can be used for the I/O ports, so that I/O port manipulation can be performed in a very efficient manner.

10.1.3 String Effect Instructions

With the μ PD75518, two types of string effect instructions are available.

- (a) MOV A,#n4 or MOV XA,#n8
- (b) MOV HL,#n8

“String effect” means the locating of these two types of instructions at contiguous addresses.

Example

```
A0      : MOV A,#0
A1      : MOV A,#1
XA7     : MOV XA,#07
```

When string effect instructions are arranged as in this example, if execution starts at address A0, the following two instructions are replaced with an NOP instruction. If execution starts at address A1, the following one instruction is replaced with an NOP instruction. That is, only the instruction first executed is valid, and any following instructions are processed as an NOP instruction.

By using string effect instructions, a constant can be set in an accumulator (the A register or the XA register pair) or data pointer (the HL register pair) more efficiently.

10.1.4 Number System Conversion Instructions

An application may need to convert the result of a 4-bit data addition or subtraction (performed in binary) to a decimal number. A time-related application may require sexagesimal conversion.

For this reason, the instruction set of the μ PD75518 contains number system conversion instructions for converting the result of a 4-bit data addition or subtraction to a number in an arbitrary number system.

(a) Number system conversion for addition

Let m be a desired number system after conversion. The following combination of instructions adds the contents of an accumulator to data in memory (HL), then converts the result of the addition to number system m .

```
ADDS A,#16-m
```

```
ADDC A,@HL ; A, CY <- A+(HL)+CY
```

```
ADDS A,#m
```

An overflow is set in the carry flag.

If the execution of the instruction `ADDC A,@HL` generates a carry, the next instruction `ADDS A,#m` is skipped. If no carry is generated, `ADDS A,#m` is executed. In this case, the skip function of this instruction (`ADDS A,#m`) is disabled, so that even if this addition generates a carry, the instruction following this instruction is not skipped. Accordingly, programs can be written after `ADDS A,#m`.

Example An accumulator is added to memory data in decimal.

```
ADDS A,#6
```

```
ADDC A,@HL ; A,CY <- A+(HL)+CY
```

```
ADDS A,#10
```

```
⋮
```

(b) Number system conversion for subtraction

Let m be a desired number system after conversion. The following combination of instructions subtracts data in memory (HL) from the contents of an accumulator, then converts the result of the subtraction to number system m .

```
SUBC A,@HL
```

```
ADDS A,#m
```

An underflow is set in the carry flag.

If the execution of the instruction `SUBC A,@HL` generates no borrow, the next instruction `ADDS A,#m` is skipped. If a borrow is generated, the instruction `ADDS A,#m` is executed. In this case, the skip function of this instruction (`ADDS A,#m`) is disabled, so that even if this addition generates a carry, the instruction following this instruction is not skipped. Accordingly, programs can be written after `ADDS A,#m`.

10.1.5 Skip Instructions and the Number of Machine Cycles Required for a Skip

The instruction set of the μ PD75518 is designed to organize a program by testing a condition with the skip function.

When a skip instruction satisfies the skip condition, the immediately following instruction is skipped to execute the instruction immediately after the skipped instruction.

A skip requires the following number of machine cycles:

- (a) When the instruction (to be skipped) immediately following the skip instruction is a 3-byte instruction (that is, the `BR !addr` or `CALL !addr` instruction):
2 machine cycles

- (b) When the instruction (to be skipped) immediately following the skip instruction is an instruction other than the instructions described in (a) above:
1 machine cycle

10.2 Instruction Set and Operation

(1) Operand identifier and description

The operand field of an instruction must contain an operand coded according to the description rule for the operand identifier of the instruction. (Refer to **RA75X Assembler Package User's Manual: Language (EEU-1343)** for detailed information.) When there are multiple descriptions for an identifier, one item is to be selected. The uppercase letters and + and – signs are keywords, which must be coded as they appear.

For immediate data, a proper numeric value or label must be coded.

The abbreviations for registers and flags shown in Chapters 3 to 6 can be coded as labels in place of mem, fmem, pmem, and bit. (However, not all labels can be coded for the fmem and pmem.)

Representation format	Description method
reg	X, A, B, C, D, E, H, L
reg1	X, B, C, D, E, H, L
rp	XA, BC, DE, HL
rp1	BC, DE, HL
rp2	BC, DE
rp'	XA, BC, DE, HL, XA', BC', DE', HL'
rp'1	BC, DE, HL, XA', BC', DE', HL'
rpa	HL, HL+, HL–, DE, DL
rpa1	DE, DL
n4	4-bit immediate data or label
n8	8-bit immediate data or label
mem	8-bit immediate data or label(Note)
bit	2-bit immediate data or label
fmem.bit	IST1, IST0, MBE, RBE, IE _{xxx} , IRQ _{xxx} , PORT _{n.m} (n = 0 to 15, m = 0 to 3)
pmem	BSB0, PORT _n (n = 0, 4, 8, 12)
addr	0000H-3F7FH immediate data or label
addr1	0000H-5F7FH immediate data or label (μPD75517) 0000H-7F7FH immediate data or label (μPD75518, μPD75P518)
caddr	12-bit immediate data or label
faddr	11-bit immediate data or label
taddr	20H-7FH immediate data (bit 0 = 0) or label
PORT _n	PORT0-PORT15
IE _{xxx}	IEBT, IECSI0, IET0, IE0, IE1, IE2, IE4, IEW, IETPG
RB _n	RB0, RB1, RB2, RB3
MB _n	MB0, MB1, MB2, MB3, MB15
(Note)	Only even address can be specified for 8-bit data processing.

(2) Legend

A:	A register, 4-bit accumulator
B:	B register, 4-bit accumulator
C:	C register, 4-bit accumulator
D:	D register, 4-bit accumulator
E:	E register, 4-bit accumulator
H:	H register, 4-bit accumulator
L:	L register, 4-bit accumulator
X:	X register, 4-bit accumulator
XA:	Register pair (XA), 8-bit accumulator
BC:	Register pair (BC), 8-bit accumulator
DE:	Register pair (DE), 8-bit accumulator
HL:	Register pair (HL), 8-bit accumulator
XA':	Extended register pair (XA')
BC':	Extended register pair (BC')
DE':	Extended register pair (DE')
HL':	Extended register pair (HL')
PC:	Program counter
SP:	Stack pointer
CY:	Carry flag, bit accumulator
PSW:	Program status word
MBE:	Memory bank enable flag
RBE:	Register bank enable flag
PORTn:	Port n (n = 0 to 15)
IME:	Interrupt master enable flag
IPS:	Interrupt priority specification register
IE _{xxx} :	Interrupt enable flag
RBS:	Register bank select register
MBS:	Memory bank select register
BS:	Bank select register
PCC:	Processor clock control register
..:	Address/bit delimiter
(xx):	Contents addressed by xx
xxH:	Hexadecimal data

(3) Explanation of symbols used for the addressing area column

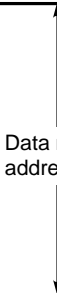
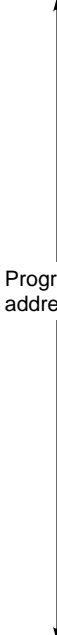
*1	MB = MBE-MBS (MBS = 0, 1, 2, 3, 15)	 Data memory addressing
*2	MB = 0	
*3	MBE = 0 : MB = 0 (000H-07FH) MB = 15 (F80H-FFFH) MBE = 1 : MB = MBS (MBS =0, 1, 2, 3, 15)	
*4	MB = 15, fmem = FB0H – FBFH, FF0H – FFFH	
*5	MB = 15, pmem = FC0H – FFFH	
*6	addr = 0000H – 3F7FH	 Program memory addressing
*7	addr = (Current PC) – 15 to (Current PC) – 1 addr = (Current PC) + 2 to (Current PC) + 16	
*8	caddr = 0000H – 0FFFH (PC _{14,13,12} = 000B: All models) 1000H – 1FFFH (PC _{14,13,12} = 001B: All models) 2000H – 2FFFH (PC _{14,13,12} = 010B: All models) 3000H – 3FFFH (PC _{14,13,12} = 011B: All models) 4000H – 4FFFH (PC _{14,13,12} = 100B: All models) 5000H – 5F7FH (PC _{14,13,12} = 101B: μPD75517) 5000H – 5FFFH (PC _{14,13,12} = 101B: μPD75518, μPD75P518) 6000H – 6FFFH (PC _{14,13,12} = 110B: μPD75518, μPD75P518) 7000H – 7F7FH (PC _{14,13,12} = 111B: μPD75518, μPD75P518)	
*9	faddr = 0000H – 07FFH	
*10	taddr = 0020H – 007FH	
*11	addr1 = 0000H – 5F7FH (μPD75517) addr1 = 0000H – 7F7FH (μPD75518, μPD75P518)	

- Remarks
1. MB represents an accessible memory bank.
 2. For * 2, MB = 0 regardless of the setting of MBE and MBS.
 3. For * 4 and * 5, MB = 15 regardless of the setting of MBE and MBS.
 4. Each of * 6 to * 11 indicates an addressable area.

(4) Explanation of the machine cycle column

S represents the number of machine cycles required when a skip instruction with the skip function performs a skip operation. S assumes one of the following values:

- When no skip operation is performed: $S = 0$
- When a 1-byte instruction or 2-byte instruction is skipped: $S = 1$
- When a 3-byte instruction(**Note**) is skipped: $S = 2$

(Note) 3-byte instruction: BR !addr, BRA !addr1, CALL !addr, and CALLA !addr1 instructions

Caution **The GETI instruction is skipped in one machine cycle.**

One machine cycle is equal to one cycle of the CPU clock (Φ), and four different machine cycles are available for selection according to the PCC setting. (See **Section 5.2.2(1)**.)

Instruction	Mnemonic	Operand	Number of bytes	Machine cycle	Operation	Addressing area	Skip condition
Transfer	MOV	A,#n4	1	1	A ← n4		String effect A
		reg1,#n4	2	2	reg1 ← n4		
		XA,#n8	2	2	XA ← n8		String effect A
		HL,#n8	2	2	HL ← n8		String effect B
		rp2,#n8	2	2	rp2 ← n8		
		A,@HL	1	1	A ← (HL)	* 1	
		A,@HL+	1	2+S	A ← (HL), then L ← L+1	* 1	L=0
		A,@HL-	1	2+S	A ← (HL), then L ← L-1	* 1	L=FH
		A,@rpa1	1	1	A ← (rpa1)	* 2	
		XA,@HL	2	2	XA ← (HL)	* 1	
		@HL,A	1	1	(HL) ← A	* 1	
		@HL,XA	2	2	(HL) ← XA	* 1	
		A,mem	2	2	A ← (mem)	* 3	
		XA,mem	2	2	XA ← (mem)	* 3	
		mem,A	2	2	(mem) ← A	* 3	
		mem,XA	2	2	(mem) ← XA	* 3	
		A,reg	2	2	A ← reg		
		XA,rp'	2	2	XA ← rp'		
	reg1,A	2	2	reg1 ← A			
	rp'1,XA	2	2	rp'1 ← XA			
	XCH	A,@HL	1	1	A ↔ (HL)	* 1	
		A,@HL+	1	2+S	A ↔ (HL), then L ← L+1	* 1	L=0
		A,@HL-	1	2+S	A ↔ (HL), then L ← L-1	* 1	L=FH
		A,@rpa1	1	1	A ↔ (rpa1)	* 2	
		XA,@HL	2	2	XA ↔ (HL)	* 1	
		A,mem	2	2	A ↔ (mem)	* 3	
XA,mem		2	2	XA ↔ (mem)	* 3		
A,reg1		1	1	A ↔ reg1			
XA,rp'		2	2	XA ↔ rp'			
Table reference	MOVT	XA,@PCDE	1	3	XA ← (PC ₁₄₋₈ +DE) _{ROM}		
		XA,@PCXA	1	3	XA ← (PC ₁₄₋₈ +XA) _{ROM}		
		XA,@BCDE(Note)	1	3	XA ← (B ₂₋₀ +CDE) _{ROM}	* 11	
		XA,@BCXA(Note)	1	3	XA ← (B ₂₋₀ +CXA) _{ROM}	* 11	

(Note) Only lower three bits are valid in the B register.

Instruction	Mnemonic	Operand	Number of bytes	Machine cycle	Operation	Addressing area	Skip condition
Bit transfer	MOV1	CY, fmem.bit	2	2	CY ← (fmem.bit)	* 4	
		CY, pmem.@L	2	2	CY ← (pmem ₇₋₂ +L ₃₋₂ .bit(L ₁₋₀))	* 5	
		CY, @H+mem.bit	2	2	CY ← (H+mem ₃₋₀ .bit)	* 1	
		fmem.bit, CY	2	2	(fmem.bit) ← CY	* 4	
		pmem.@L, CY	2	2	(pmem ₇₋₂ +L ₃₋₂ .bit(L ₁₋₀)) ← CY	* 5	
		@H+mem.bit, CY	2	2	(H+mem ₃₋₀ .bit) ← CY	* 1	
Arithmetic/logical	ADDS	A, #n4	1	1+S	A ← A+n4		carry
		XA, #n8	2	2+S	XA ← XA+n8		carry
		A, @HL	1	1+S	A ← A+(HL)	* 1	carry
		XA, rp'	2	2+S	XA ← XA+rp'		carry
		rp'1, XA	2	2+S	rp'1 ← rp'1+XA		carry
	ADDC	A, @HL	1	1	A, CY ← A+(HL)+CY	* 1	
		XA, rp'	2	2	XA, CY ← XA+rp'+CY		
		rp'1, XA	2	2	rp'1, CY ← rp'1+XA+CY		
	SUBS	A, @HL	1	1+S	A ← A-(HL)	* 1	borrow
		XA, rp'	2	2+S	XA ← XA-rp'		borrow
		rp'1, XA	2	2+S	rp'1 ← rp'1-XA		borrow
	SUBC	A, @HL	1	1	A, CY ← A-(HL)-CY	* 1	
		XA, rp'	2	2	XA, CY ← XA-rp'-CY		
		rp'1, XA	2	2	rp'1, CY ← rp'1-XA-CY		
	AND	A, #n4	2	2	A ← A∧n4		
		A, @HL	1	1	A ← A∧(HL)	* 1	
		XA, rp'	2	2	XA ← XA∧rp'		
		rp'1, XA	2	2	rp'1 ← rp'1∧XA		
	OR	A, #n4	2	2	A ← A∨n4		
		A, @HL	1	1	A ← A∨(HL)	* 1	
		XA, rp'	2	2	XA ← XA∨rp'		
		rp'1, XA	2	2	rp'1 ← rp'1∨XA		
	XOR	A, #n4	2	2	A ← A⊕n4		
		A, @HL	1	1	A ← A⊕(HL)	* 1	
XA, rp'		2	2	XA ← XA⊕rp'			
rp'1, XA		2	2	rp'1 ← rp'1⊕XA			

Instruction	Mnemonic	Operand	Number of bytes	Machine cycle	Operation	Addressing area	Skip condition
Accumulator manipulation	RORC	A	1	1	$CY \leftarrow A_0, A_3 \leftarrow CY, A_{n-1} \leftarrow A_n$		
	NOT	A	2	2	$A \leftarrow \bar{A}$		
Increment/decrement	INCS	reg	1	1+S	$reg \leftarrow reg+1$		reg=0
		rp1	1	1+S	$rp1 \leftarrow rp1+1$		rp1=00H
		@HL	2	2+S	$(HL) \leftarrow (HL)+1$	* 1	(HL)=0
		mem	2	2+S	$(mem) \leftarrow (mem)+1$	* 3	(mem)=0
	DECS	reg	1	1+S	$reg \leftarrow reg-1$		reg=FFH
		rp'	2	2+S	$rp' \leftarrow rp'-1$		rp'=FFH
Comparison	SKE	reg,#n4	2	2+S	Skip if reg=n4		reg=n4
		@HL,#n4	2	2+S	Skip if (HL)=n4	* 1	(HL)=n4
		A,@HL	1	1+S	Skip if A=(HL)	* 1	A=(HL)
		XA,@HL	2	2+S	Skip if XA=(HL)	* 1	XA=(HL)
		A,reg	2	2+S	Skip if A=reg		A=reg
		XA,rp'	2	2+S	Skip if XA=rp'		XA=rp'
Carry flags manipulation	SET1	CY	1	1	$CY \leftarrow 1$		
	CLR1	CY	1	1	$CY \leftarrow 0$		
	SKT	CY	1	1+S	Skip if CY=1		CY=1
	NOT1	CY	1	1	$CY \leftarrow \overline{CY}$		

Instruction	Mnemonic	Operand	Number of bytes	Machine cycle	Operation	Addressing area	Skip condition
Memory bit manipulation	SET1	mem.bit	2	2	(mem.bit) <- 1	* 3	
		fmem.bit	2	2	(fmem.bit) <- 1	* 4	
		pmem.@L	2	2	(pmem ₇₋₂ +L ₃₋₂ .bit(L ₁₋₀)) <- 1	* 5	
		@H+mem.bit	2	2	(H+mem ₃₋₀ .bit) <- 1	* 1	
	CLR1	mem.bit	2	2	(mem.bit) <- 0	* 3	
		fmem.bit	2	2	(fmem.bit) <- 0	* 4	
		pmem.@L	2	2	(pmem ₇₋₂ +L ₃₋₂ .bit(L ₁₋₀)) <- 0	* 5	
		@H+mem.bit	2	2	(H+mem ₃₋₀ .bit) <- 0	* 1	
	SKT	mem.bit	2	2+S	Skip if (mem.bit)=1	* 3	(mem.bit)=1
		fmem.bit	2	2+S	Skip if (fmem.bit)=1	* 4	(fmem.bit)=1
		pmem.@L	2	2+S	Skip if (pmem ₇₋₂ +L ₃₋₂ .bit(L ₁₋₀))=1	* 5	(pmem.@L)=1
		@H+mem.bit	2	2+S	Skip if (H+mem ₃₋₀ .bit)=1	* 1	(@H+mem.bit)=1
	SKF	mem.bit	2	2+S	Skip if (mem.bit)=0	* 3	(mem.bit)=0
		fmem.bit	2	2+S	Skip if (fmem.bit)=0	* 4	(fmem.bit)=0
		pmem.@L	2	2+S	Skip if (pmem ₇₋₂ +L ₃₋₂ .bit(L ₁₋₀))=0	* 5	(pmem.@L)=0
		@H+mem.bit	2	2+S	Skip if (H+mem ₃₋₀ .bit)=0	* 1	(@H+mem.bit)=0
	SKTCLR	fmem.bit	2	2+S	Skip if (fmem.bit)=1 and clear	* 4	(fmem.bit)=1
		pmem.@L	2	2+S	Skip if (pmem ₇₋₂ +L ₃₋₂ .bit(L ₁₋₀))=1 and clear	* 5	(pmem.@L)=1
		@H+mem.bit	2	2+S	Skip if (H+mem ₃₋₀ .bit)=1 and clear	* 1	(@H+mem.bit)=1
	AND1	CY,fmem.bit	2	2	CY <- CY ∧ (fmem.bit)	* 4	
		CY,pmem.@L	2	2	CY <- CY ∧ (pmem ₇₋₂ +L ₃₋₂ .bit(L ₁₋₀))	* 5	
		CY,@H+mem.bit	2	2	CY <- CY ∧ (H+mem ₃₋₀ .bit)	* 1	
	OR1	CY,fmem.bit	2	2	CY <- CY ∨ (fmem.bit)	* 4	
		CY,pmem.@L	2	2	CY <- CY ∨ (pmem ₇₋₂ +L ₃₋₂ .bit(L ₁₋₀))	* 5	
CY,@H+mem.bit		2	2	CY <- CY ∨ (H+mem ₃₋₀ .bit)	* 1		
XOR1	CY,fmem.bit	2	2	CY <- CY ⊕ (fmem.bit)	* 4		
	CY,pmem.@L	2	2	CY <- CY ⊕ (pmem ₇₋₂ +L ₃₋₂ .bit(L ₁₋₀))	* 5		
	CY,@H+mem.bit	2	2	CY <- CY ⊕ (H+mem ₃₋₀ .bit)	* 1		

Instruction	Mnemonic	Operand	Number of bytes	Machine cycle	Operation	Addressing area	Skip condition
Branch	BR	addr1	—	—	PC ₁₄₋₀ ← addr1 (The assembler selects an appropriate instruction from the BR !addr, BRA !addr1, BRCB !caddr, and BR \$addr instructions.)	* 11	
		!addr	3	3	PC ₁₄ ← 0, PC ₁₃₋₀ ← !addr	* 6	
		\$addr	1	2	PC ₁₄₋₀ ← addr	* 7	
		PCDE	2	3	PC ₁₄₋₀ ← PC ₁₄₋₈ +DE		
		PCXA	2	3	PC ₁₄₋₀ ← PC ₁₄₋₈ +XA		
		BCDE(Note)	2	3	PC ₁₄₋₀ ← B ₂₋₀ + CDE	* 11	
		BCXA(Note)	2	3	PC ₁₄₋₀ ← B ₂₋₀ + CXA	* 11	
		BRA	!addr1	3	3	PC ₁₄₋₀ ← !addr1	* 11
	BRCB	!caddr	2	2	PC ₁₄₋₀ ← PC _{14,13,12} +caddr ₁₁₋₀	* 8	
Subroutine stack control	CALL	!addr	3	4	(SP-2) ← x,x,MBE,RBE (SP-6)(SP-3)(SP-4) ← PC ₁₁₋₀ (SP-5) ← 0,PC ₁₄ ,PC ₁₃ , PC ₁₂ PC ₁₄ ← 0, PC ₁₃₋₀ ← addr, SP ← SP-6	* 6	
	CALLA	!addr1	3	3	(SP-2) ← x,x,MBE,RBE (SP-6)(SP-3)(SP-4) ← PC ₁₁₋₀ (SP-5) ← 0,PC ₁₄ ,PC ₁₃ , PC ₁₂ PC ₁₄₋₀ ← addr, SP ← SP-6	* 11	
	CALLF	!faddr	2	3	(SP-2) ← x,x,MBE,RBE (SP-6)(SP-3)(SP-4) ← PC ₁₁₋₀ (SP-5) ← 0,PC ₁₄ ,PC ₁₃ , PC ₁₂ PC ₁₄₋₀ ← 0000+faddr, SP ← SP-6	* 9	
	RET		1	3	PC ₁₁₋₀ ← (SP)(SP+3)(SP+2) x,PC ₁₄ ,PC ₁₃ ,PC ₁₂ ← (SP+1) x,x,MBE,RBE ← (SP+4) SP ← SP+6		
	RETS		1	3+S	PC ₁₁₋₀ ← (SP)(SP+3)(SP+2) x,PC ₁₄ ,PC ₁₃ ,PC ₁₂ ← (SP+1) x,x,MBE,RBE ← (SP+4) SP ← SP+6 Then skip unconditionally		Unconditionally
	RETI		1	3	PC ₁₁₋₀ ← (SP)(SP+3)(SP+2) x,PC ₁₄ ,PC ₁₃ ,PC ₁₂ ← (SP+1) PSW ← (SP+4)(SP+5), SP ← SP+6		

(Note) Only lower three bits are valid in the B register.

Instruction	Mnemonic	Operand	Number of bytes	Machine cycle	Operation	Addressing area	Skip condition
Subroutine stack	PUSH	rp	1	1	(SP-1)(SP-2) <- rp, SP <- SP-2		
		BS	2	2	(SP-1) <- MBS, (SP-2) <- RBS, SP <- SP-2		
	POP	rp	1	1	rp <- (SP+1)(SP), SP <- SP+2		
		BS	2	2	MBS <- (SP+1), RBS <- (SP), SP <- SP+2		
Interrupt control	EI		2	2	IME(IPS.3) <- 1		
		IExxx	2	2	IExxx <- 1		
	DI		2	2	IME(IPS.3) <- 0		
		IExxx	2	2	IExxx <- 0		
I/O	IN(Note)	A,PORTn	2	2	A <- PORTn (n=0-15)		
		XA,PORTn	2	2	XA <- PORT _{n+1} , PORTn (n=4,6)		
	OUT(Note)	PORTn,A	2	2	PORTn <- A (n=2-7,9-14)		
		PORTn,XA	2	2	PORT _{n+1} ,PORTn <- XA (n=4,6)		
CPU control	HALT		2	2	Set HALT Mode (PCC.2 <- 1)		
	STOP		2	2	Set STOP Mode (PCC.3 <- 1)		
	NOP		1	1	No Operation		
Special	SEL	RBn	2	2	RBS <- n (n=0-3)		
		MBn	2	2	MBS <- n (n=0,1,2,3,15)		
	GETI	taddr	1	3	For a TBR instruction PC ₁₃₋₀ <- (taddr) ₄₋₀ +(taddr+1) PC ₁₄ <- 0	* 10	
				4	For a TCALL instruction (SP-5)(SP-6)(SP-3)(SP-4) <- x,PC ₁₄₋₀ (SP-2) <- x,x,MBE,RBE PC ₁₃₋₀ <- (taddr) ₅₋₀ +(taddr+1) SP <- SP-6 PC ₁₄ <- 0		
				3	For an instruction other than TBR and TCALL (taddr)(taddr+1)		

(Note) MBE = 0, or MBE = 1 and MBS = 15 must be set when an IN/OUT instruction is executed.

Remark The TBR and TCALL instructions are table definition assembler pseudo instructions of the GETI instructions.

10.3 Instruction Codes of Each Instruction

(1) Explanations of the symbols for the instruction codes

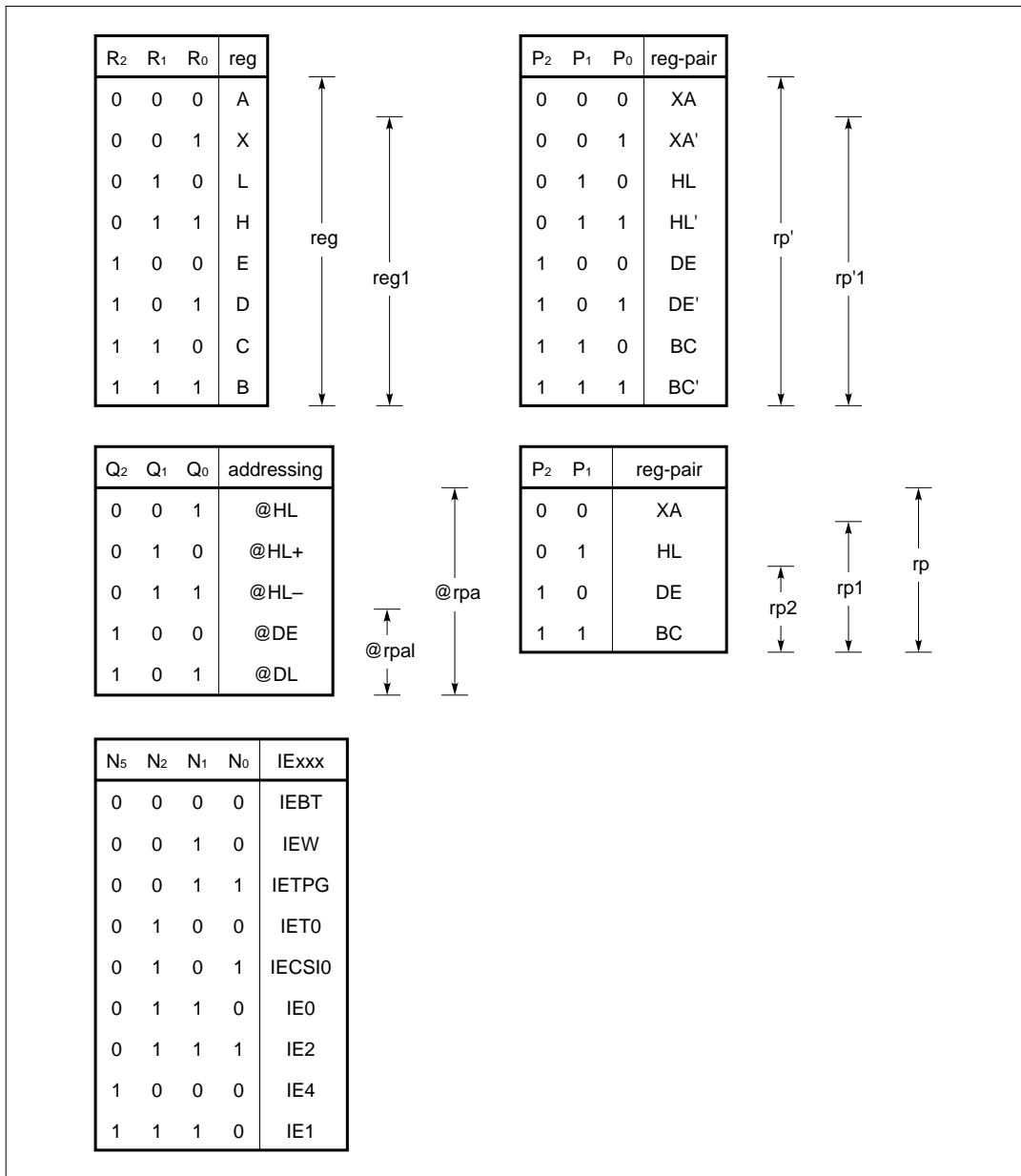

In : Immediate data for n4 or n8

Dn: Immediate data for mem

Bn: Immediate data for bit

Nn: Immediate data for n or IE_{xxx}

Tn: Immediate data for taddr x 1/2

An: Immediate data for the address (2 to 16) relative to branch destination address minus one

Sn: Immediate data for the one's complement of the address (15 to 1) relative to the branch destination address

(2) Bit manipulation addressing instruction codes

*1 in the operand field indicates that there are three types of bit manipulation addressing, fmem.bit, pmem.@L, and @H+mem.bit.

The table below lists the second byte *2 of an instruction code corresponding to the above addressing.

* 1	* 2 Second byte of instruction code	Accessible bits
fmem.bit	1 0 B ₁ B ₀ F ₃ F ₂ F ₁ F ₀	FB0H-FBFH manipulatable bits
	1 1 B ₁ B ₀ F ₃ F ₂ F ₁ F ₀	FF0H-FFFH manipulatable bits
pmem.@L	0 1 0 0 G ₃ G ₂ G ₁ G ₀	FC0H-FFFH manipulatable bits
@H+mem.bit	0 0 B ₁ B ₀ D ₃ D ₂ D ₁ D ₀	Manipulatable bits of accessible memory bank

B_n : Immediate data for bit

F_n : Immediate data for fmem (Low-order four bits of address)

G_n : Immediate data for pmem (Bits 2 to 5 of address)

D_n : Immediate data for mem (Low-order four bits of address)

Instruction	Mnemonic	Operand	Instruction code		
			B ₁	B ₂	B ₃
Transfer	MOV	A,#n4	0 1 1 1 I ₃ I ₂ I ₁ I ₀		
		reg1,#n4	1 0 0 1 1 0 1 0	I ₃ I ₂ I ₁ I ₀ 1 R ₂ R ₁ R ₀	
		rp,#n8	1 0 0 0 1 P ₂ P ₁ 1	I ₇ I ₆ I ₅ I ₄ I ₃ I ₂ I ₁ I ₀	
		A,@rpa	1 1 1 0 0 Q ₂ Q ₁ Q ₀		
		XA,@HL	1 0 1 0 1 0 1 0	0 0 0 1 1 0 0 0	
		@HL,A	1 1 1 0 1 0 0 0		
		@HL,XA	1 0 1 0 1 0 1 0	0 0 0 1 0 0 0 0	
		A,mem	1 0 1 0 0 0 1 1	D ₇ D ₆ D ₅ D ₄ D ₃ D ₂ D ₁ D ₀	
		XA,mem	1 0 1 0 0 0 1 0	D ₇ D ₆ D ₅ D ₄ D ₃ D ₂ D ₁ D ₀	
		mem,A	1 0 0 1 0 0 1 1	D ₇ D ₆ D ₅ D ₄ D ₃ D ₂ D ₁ D ₀	
		mem,XA	1 0 0 1 0 0 1 0	D ₇ D ₆ D ₅ D ₄ D ₃ D ₂ D ₁ D ₀	
		A,reg	1 0 0 1 1 0 0 1	0 1 1 1 1 R ₂ R ₁ R ₀	
		XA,rp'	1 0 1 0 1 0 1 0	0 1 0 1 1 P ₂ P ₁ P ₀	
		reg1,A	1 0 0 1 1 0 0 1	0 1 1 1 0 R ₂ R ₁ R ₀	
		rp'1,XA	1 0 1 0 1 0 1 0	0 1 0 1 0 P ₂ P ₁ P ₀	
	XCH	A,@rpa	1 1 1 0 1 Q ₂ Q ₁ Q ₀		
		XA,@HL	1 0 1 0 1 0 1 0	0 0 0 1 0 0 0 1	
		A,mem	1 0 1 1 0 0 1 1	D ₇ D ₆ D ₅ D ₄ D ₃ D ₂ D ₁ D ₀	
		XA,mem	1 0 1 1 0 0 1 0	D ₇ D ₆ D ₅ D ₄ D ₃ D ₂ D ₁ 0	
		A,reg1	1 1 0 1 1 R ₂ R ₁ R ₀		
XA,rp'		1 0 1 0 1 0 1 0	0 1 0 0 0 P ₂ P ₁ P ₀		
Table reference	MOVT	XA,@PCDE	1 1 0 1 0 1 0 0		
		XA,@PCXA	1 1 0 1 0 0 0 0		
		XA,@BCDE	1 1 0 1 0 1 0 1		
		XA,@BCXA	1 1 0 1 0 0 0 1		
Bit transfer	MOV1	CY, *1	1 0 1 1 1 1 0 1	*2	
		*1,CY	1 0 0 1 1 0 1 1	*2	

Instruction	Mnemonic	Operand	Instruction code		
			B ₁	B ₂	B ₃
Arithmetic/ logical	ADDS	A,#n4	0 1 1 0 l ₃ l ₂ l ₁ l ₀		
		XA,#n8	1 0 1 1 1 0 0 1	l ₇ l ₆ l ₅ l ₄ l ₃ l ₂ l ₁ l ₀	
		A,@HL	1 1 0 1 0 0 1 0		
		XA,rp'	1 0 1 0 1 0 1 0	1 1 0 0 1 P ₂ P ₁ P ₀	
		rp'1,XA	1 0 1 0 1 0 1 0	1 1 0 0 0 P ₂ P ₁ P ₀	
	ADDC	A,@HL	1 0 1 0 1 0 0 1		
		XA,rp'	1 0 1 0 1 0 1 0	1 1 0 1 1 P ₂ P ₁ P ₀	
		rp'1,XA	1 0 1 0 1 0 1 0	1 1 0 1 0 P ₂ P ₁ P ₀	
	SUBS	A,@HL	1 0 1 0 1 0 0 0		
		XA,rp'	1 0 1 0 1 0 1 0	1 1 1 0 1 P ₂ P ₁ P ₀	
		rp'1,XA	1 0 1 0 1 0 1 0	1 1 1 0 0 P ₂ P ₁ P ₀	
	SUBC	A,@HL	1 0 1 1 1 0 0 0		
		XA,rp'	1 0 1 0 1 0 1 0	1 1 1 1 1 P ₂ P ₁ P ₀	
		rp'1,XA	1 0 1 0 1 0 1 0	1 1 1 1 0 P ₂ P ₁ P ₀	
	AND	A,#n4	1 0 0 1 1 0 0 1	0 0 1 1 l ₃ l ₂ l ₁ l ₀	
		A,@HL	1 0 0 1 0 0 0 0		
		XA,rp'	1 0 1 0 1 0 1 0	1 0 0 1 1 P ₂ P ₁ P ₀	
		rp'1,XA	1 0 1 0 1 0 1 0	1 0 0 1 0 P ₂ P ₁ P ₀	
	OR	A,#n4	1 0 0 1 1 0 0 1	0 1 0 0 l ₃ l ₂ l ₁ l ₀	
		A,@HL	1 0 1 0 0 0 0 0		
		XA,rp'	1 0 1 0 1 0 1 0	1 0 1 0 1 P ₂ P ₁ P ₀	
		rp'1,XA	1 0 1 0 1 0 1 0	1 0 1 0 0 P ₂ P ₁ P ₀	
	XOR	A,#n4	1 0 0 1 1 0 0 1	0 1 0 1 l ₃ l ₂ l ₁ l ₀	
		A,@HL	1 0 1 1 0 0 0 0		
XA,rp'		1 0 1 0 1 0 1 0	1 0 1 1 1 P ₂ P ₁ P ₀		
rp'1,XA		1 0 1 0 1 0 1 0	1 0 1 1 0 P ₂ P ₁ P ₀		
Accumulator manipulation	RORC	A	1 0 0 1 1 0 0 0		
	NOT	A	1 0 0 1 1 0 0 1	0 1 0 1 1 1 1 1	

Instruction	Mnemonic	Operand	Instruction code		
			B ₁	B ₂	B ₃
Increment/ decrement	INCS	reg	1 1 0 0 0 R ₂ R ₁ R ₀		
		rp1	1 0 0 0 1 P ₂ P ₁ 0		
		@HL	1 0 0 1 1 0 0 1	0 0 0 0 0 0 1 0	
		mem	1 0 0 0 0 0 1 0	D ₇ D ₆ D ₅ D ₄ D ₃ D ₂ D ₁ D ₀	
	DECS	reg	1 1 0 0 1 R ₂ R ₁ R ₀		
		rp'	1 0 1 0 1 0 1 0	0 1 1 0 1 P ₂ P ₁ P ₀	
Comparison	SKE	reg,#n4	1 0 0 1 1 0 1 0	I ₃ I ₂ I ₁ I ₀ 0 R ₂ R ₁ R ₀	
		@HL,#n4	1 0 0 1 1 0 0 1	0 1 1 0 I ₃ I ₂ I ₁ I ₀	
		A,@HL	1 0 0 0 0 0 0 0		
		XA,@HL	1 0 1 0 1 0 1 0	0 0 0 1 1 0 0 1	
		A,reg	1 0 0 1 1 0 0 1	0 0 0 0 1 R ₂ R ₁ R ₀	
		XA,rp'	1 0 1 0 1 0 1 0	0 1 0 0 1 P ₂ P ₁ P ₀	
Carry flag manipulation	SET1	CY	1 1 1 0 0 1 1 1		
	CLR1	CY	1 1 1 0 0 1 1 0		
	SKT	CY	1 1 0 1 0 1 1 1		
	NOT1	CY	1 1 0 1 0 1 1 0		
Memory bit manipulation	SET1	mem.bit	1 0 B ₁ B ₀ 0 1 0 1	D ₇ D ₆ D ₅ D ₄ D ₃ D ₂ D ₁ D ₀	
		<input type="checkbox"/> * 1	1 0 0 1 1 1 0 1	* 2	
	CLR1	mem.bit	1 0 B ₁ B ₀ 0 1 0 0	D ₇ D ₆ D ₅ D ₄ D ₃ D ₂ D ₁ D ₀	
		<input type="checkbox"/> * 1	1 0 0 1 1 1 0 0	* 2	
	SKT	mem.bit	1 0 B ₁ B ₀ 0 1 1 1	D ₇ D ₆ D ₅ D ₄ D ₃ D ₂ D ₁ D ₀	
		<input type="checkbox"/> * 1	1 0 1 1 1 1 1 1	* 2	
	SKF	mem.bit	1 0 B ₁ B ₀ 0 1 1 0	D ₇ D ₆ D ₅ D ₄ D ₃ D ₂ D ₁ D ₀	
		<input type="checkbox"/> * 1	1 0 1 1 1 1 1 0	* 2	
	SKTCLR	<input type="checkbox"/> * 1	1 0 0 1 1 1 1 1	* 2	
	AND1	CY, <input type="checkbox"/> * 1	1 0 1 0 1 1 0 0	* 2	
	OR1	CY, <input type="checkbox"/> * 1	1 0 1 0 1 1 1 0	* 2	
	XOR1	CY, <input type="checkbox"/> * 1	1 0 1 1 1 1 0 0	* 2	

Instruction	Mnemonic	Operand	Instruction code		
			B ₁	B ₂	B ₃
Branch	BR	!addr	1 0 1 0 1 0 1 1	0 0 ←	addr →
		\$addr (+16) to (+2)	0 0 0 0 A ₃ A ₂ A ₁ A ₀		
		(-1) to (-15)	1 1 1 1 S ₃ S ₂ S ₁ S ₀		
		PCDE	1 0 0 1 1 0 0 1	0 0 0 0 0 1 0 0	
		PCXA	1 0 0 1 1 0 0 1	0 0 0 0 0 0 0 0	
		BCDE	1 0 0 1 1 0 0 1	0 0 0 0 0 1 0 1	
	BCXA	1 0 0 1 1 0 0 1	0 0 0 0 0 0 0 1		
	BRA	!addr1	1 0 1 1 1 0 1 0	0 ←	addr1 →
	BRCB	!caddr	0 1 0 1 ←	caddr →	
Sub-routine stack control	CALL	!addr	1 0 1 0 1 0 1 1	0 1 ←	addr →
	CALLA	!addr1	1 0 1 1 1 0 1 1	0 ←	addr1 →
	CALLF	!faddr	0 1 0 0 0 ←	faddr →	
	RET		1 1 1 0 1 1 1 0		
	RETS		1 1 1 0 0 0 0 0		
	RETI		1 1 1 0 1 1 1 1		
	PUSH	rp	0 1 0 0 1 P ₂ P ₁ 1		
		BS	1 0 0 1 1 0 0 1	0 0 0 0 0 1 1 1	
POP	rp	0 1 0 0 1 P ₂ P ₁ 0			
	BS	1 0 0 1 1 0 0 1	0 0 0 0 0 1 1 0		
I/O	IN	A,PORTn	1 0 1 0 0 0 1 1	1 1 1 1 N ₃ N ₂ N ₁ N ₀	
		XA,PORTn	1 0 1 0 0 0 1 0	1 1 1 1 N ₃ N ₂ N ₁ N ₀	
	OUT	PORTn,A	1 0 0 1 0 0 1 1	1 1 1 1 N ₃ N ₂ N ₁ N ₀	
		PORTn,XA	1 0 0 1 0 0 1 0	1 1 1 1 N ₃ N ₂ N ₁ N ₀	
Interrupt control	EI		1 0 0 1 1 1 0 1	1 0 1 1 0 0 1 0	
		IExxx	1 0 0 1 1 1 0 1	1 0 N ₅ 1 1 N ₂ N ₁ N ₀	
	DI		1 0 0 1 1 1 0 0	1 0 1 1 0 0 1 0	
		IExxx	1 0 0 1 1 1 0 0	1 0 N ₅ 1 1 N ₂ N ₁ N ₀	
CPU control	HALT		1 0 0 1 1 1 0 1	1 0 1 0 0 0 1 1	
	STOP		1 0 0 1 1 1 0 1	1 0 1 1 0 0 1 1	
	NOP		0 1 1 0 0 0 0 0		
Special	SEL	RBn	1 0 0 1 1 0 0 1	0 0 1 0 0 0 N ₁ N ₀	
		MBn	1 0 0 1 1 0 0 1	0 0 0 1 N ₃ N ₂ N ₁ N ₀	
	GETI	taddr	0 0 T ₅ T ₄ T ₃ T ₂ T ₁ T ₀		

10.4 Functions and Applications of the Instructions

10.4.1 Transfer Instructions

MOV A,#n4

Function: A ← n4 n4 = I₃₋₀: 0-FH

Transfers the 4-bit immediate data n4 to the A register (4-bit accumulator).

The string effect (group A) can be utilized. When MOV A,#n4 and/or MOV XA,#n8 instructions are located contiguously, the string instructions following an executed instruction are processed as NOP instructions.

Examples

- (1) The data 0BH is set in the accumulator.

```
MOV A,#0BH
```

- (2) Data to be output to port 3 is selected from 0 to 2.

```
A0 : MOV A,#0
```

```
A1 : MOV A,#1
```

```
A2 : MOV A,#2
```

```
OUT PORT3,A
```

MOV reg1,#n4

Function: reg1 ← n4 n4 = I₃₋₀: 0-FH

Transfers the 4-bit immediate data n4 to register reg1 (A, X, H, L, D, E, B, C).

MOV rp,#n8

Function rp ← n8 n8 = I₇₋₀: 00H-FFH

Transfers the 8-bit immediate data n8 to register pair rp (XA, HL, DE, BC).

When XA or HL is specified as rp, a string effect can be utilized. There are two types of string effects: group A (MOV A,#n4 instruction and MOV XA,#n8 instruction) and group B (MOV HL,#n8 instruction). When instructions in the same group are located contiguously, the string instructions following an executed instruction are processed as NOP instructions.

Example

The data 5FH is set in the DE register pair.

```
MOV DE,#5FH
```

MOV A,@rpa

Function: $A \leftarrow (rpa)$

When $rpa = HL+$: Skip if $L = 0$

When $rpa = HL-$: Skip if $L = FH$

Transfers the data at the data memory location addressed by register pair rpa (HL , $HL+$, $HL-$, DE , DL) to the A register.

When $HL+$ (automatic increment) is specified as rpa , automatically increments the contents of the L register by one after the data transfer, and continues the operation until the contents are set to 0. Then skips the immediately following instruction.

When $HL-$ (automatic decrement) is specified as rpa , automatically decrements the contents of the L register by one after the data transfer, and continues the operation until the contents are set to FH . Then skips the immediately following instruction.

MOV XA,@HL

Function: $A \leftarrow (HL)$, $X \leftarrow (HL+1)$

Transfers the data at the data memory location addressed by the HL register pair to the A register, and transfers the data at the next data memory address to the X register.

However, if the contents of the L register are odd-numbered, an address with the low-order bit ignored is specified.

Example

The data at addresses $3EH$ and $3FH$ are transferred to the XA register pair.

```
MOV HL,#3EH
```

```
MOV XA,@HL
```

MOV @HL,A

Function: $(HL) \leftarrow A$

Transfers the contents of the A register to the data memory location addressed by the HL register pair.

MOV @HL,XA

Function: $(HL) \leftarrow A$, $(HL+1) \leftarrow X$

Transfers the contents of the A register to the data memory location addressed by the HL register pair, and transfers the contents of the X register to the next memory address.

However, if the contents of the L register are odd-numbered, an address with the low-order bit ignored is specified.

MOV A,mem**Function:** $A \leftarrow (\text{mem})$ mem = D₇₋₀: 00H-FFH

Transfers the data at the data memory location addressed by the 8-bit immediate data mem to the A register.

MOV XA,mem**Function:** $A \leftarrow (\text{mem}), X \leftarrow (\text{mem}+1)$ mem = D₇₋₀: 00H-FEH

Transfers the data at the data memory location addressed by the 8-bit immediate data mem to the A register, and transfers the data at the next address to the X register.

An even address can be specified with mem.

Example

The data at addresses 40H and 41H are transferred to the XA register pair.

```
MOV XA,40H
```

MOV mem,A**Function:** $(\text{mem}) \leftarrow A$ mem = D₇₋₀: 00H-FFH

Transfers the contents of the A register to the data memory location addressed by the 8-bit immediate data mem.

MOV mem,XA**Function:** $(\text{mem}) \leftarrow A, (\text{mem}+1) \leftarrow X$ mem = D₇₋₀: 00H-FEH

Transfers the contents of the A register to the data memory location addressed by the 8-bit immediate data mem, and transfers the contents of the X register to the next memory address.

An even address can be specified with mem.

MOV A,reg**Function:** $A \leftarrow \text{reg}$

Transfers the contents of register reg (X, A, H, L, D, E, B, C) to the A register.

MOV XA,rp'**Function:** $XA \leftarrow \text{rp}'$

Transfers the contents of register pair rp' (XA, HL, DE, BC, XA', HL', DE', BC') to the XA register pair.

Example

The contents of the XA' register pair are transferred to the XA register pair.

```
MOV XA, XA'
```

MOV reg1,A**Function:** reg1 <- A

Transfers the contents of the A register to register reg1 (X, H, L, D, E, B, C).

MOV rp'1,XA**Function:** rp'1 <- XA

Transfers the contents of the XA register pair to register pair rp'1 (HL, DE, BC, XA', HL', DE', BC').

XCH A,@rpa**Function:** A <-> (rpa)

When rpa = HL+: Skip if L = 0

When rpa = HL-: Skip if L = FH

Exchanges the contents of the A register with the data at the data memory location addressed by register pair rpa (HL, HL+, HL-, DE, DL). When HL+ (automatic increment) or HL- (automatic decrement) is specified as rpa, automatically increments or decrements the contents of the L register by one after the data exchange, and continues this operation until the contents are set to 0 for HL+ or FH for HL-. Then skips the immediately following instruction.

Example

The data at addresses 20H-2FH are exchanged with the data at addresses 30H-3FH.

```

SEL    MB0
MOV    D,#2
MOV    HL,#30H
LOOP : XCH  A,@HL    ; A <-> (3x)
      XCH  A,@DL    ; A <-> (2x)
      XCH  A,@HL+   ; A <-> (3x)
BR     LOOP

```

XCH XA,@HL**Function:** A <-> (HL), X <-> (HL+1)

Exchanges the contents of the A register with the data at the data memory location addressed by the HL register pair, and exchanges the contents of the X register with the data at the next memory address.

However, if the contents of the L register are odd- numbered, an address with the low-order bit ignored is specified.

XCH A,mem**Function:** A \leftrightarrow (mem) mem = D₇₋₀: 00H-FEH

Exchanges the contents of the A register with the data at the data memory location addressed by the 8-bit immediate data mem.

XCH XA,mem**Function:** A \leftrightarrow (mem), X \leftrightarrow (mem+1) mem = D₇₋₀: 00H-FEH

Exchanges the contents of the A register with the data at the data memory location addressed by the 8-bit immediate data mem, and exchanges the contents of the X register 1 with the data at the next memory address.

An even address can be specified with mem.

XCH A,reg1**Function:** A \leftrightarrow reg1

Exchanges the contents of the A register with register reg1 (X, H, L, D, E, B, C).

XCH XA,rp'**Function:** XA \leftrightarrow rp'

Exchanges the contents of the XA register pair with the contents of register pair rp' (XA, HL, DE, BC, XA', HL', DE', BC').

10.4.2 Table Reference Instructions

MOVT XA,@PCDE

Function: $XA \leftarrow ROM(PC_{14-8}+DE)$

Transfers the low-order four bits of the table data in program memory to the A register, and the high-order four bits to the X register. The table data is addressed by the program counter (PC) with its low-order eight bits (PC_{7-0}) exchanged with the contents of the DE register pair.

The table address is determined by the contents of the program counter (PC) present when this instruction is executed.

The table area must have necessary data loaded by an assembler pseudo instruction (DB instruction).

The program counter is not affected by the execution of the pseudo instruction.

This instruction is useful for consecutive table data references.

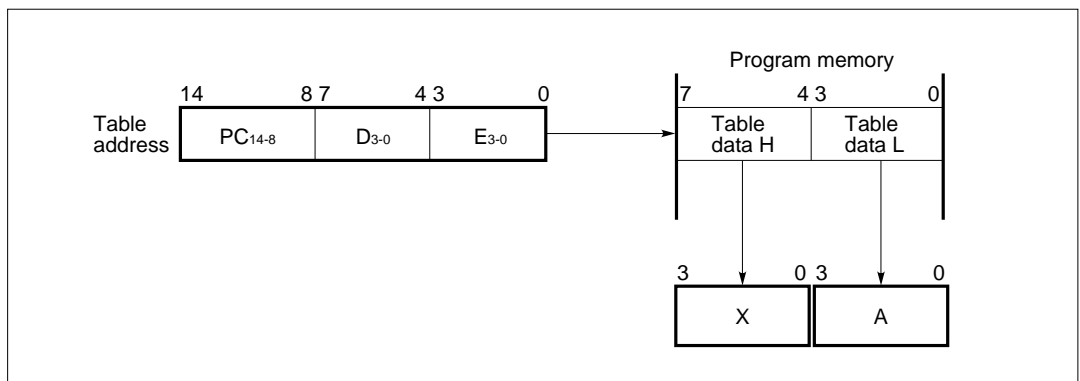

Caution The `MOVT XA,@PCDE` instruction usually references table data in the page containing that instruction. However, when the instruction is located at address `xxFFH`, table data in the next page is referenced instead of table data in the page containing that instruction.

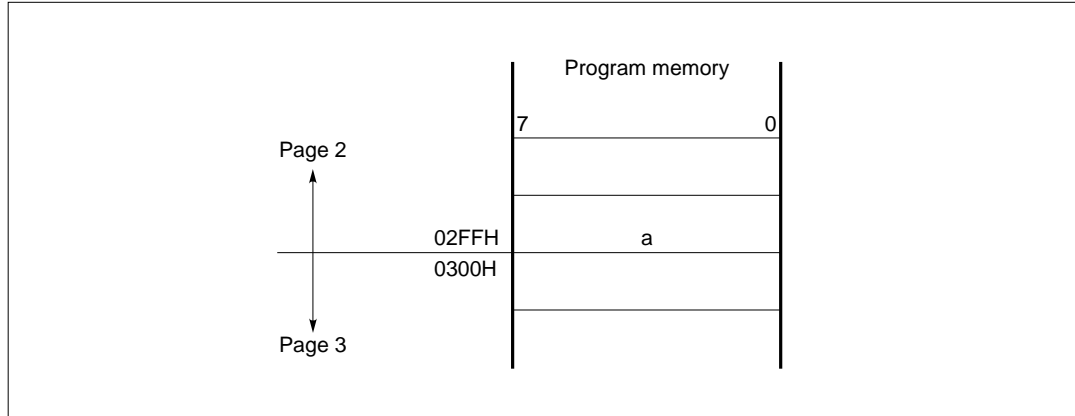

For example, if `MOVT XA,@PCDE` is located at `a` as shown above, the table data in page 3 specified by the contents of the DE register pair is transferred to the XA register pair instead of that in page 2.

Example

The 16-byte data at addresses `xxF0H-xxFFH` in program memory is transferred to addresses `30H-4FH` in data memory.

```

SUB : SEL    MB0
      MOV    HL,#30H    ; HL <- 30H
      MOV    DE,#0F0H   ; DE <- F0H
LOOP: MOVT   XA,@PCDE   ; XA <- table data
      MOV    @HL,XA     ; (HL) <- XA
      INCS   HL         ; HL <- HL+2
      INCS   HL
      INCS   E         ; E <- E+1
      BR    LOOP
      RET
      ORG   xxF0H
      DB   xxH,xxH, ..... ; Table data
    
```

MOVT XA,@PCXA

Function: XA <- ROM (PC₁₄₋₈+XA)

Transfers the low-order four bits of the table data in program memory to the A register, and the high-order four bits to the X register. The table data is addressed by the program counter (PC) with its low-order eight bits (PC₇₋₀) exchanged with the contents of the XA register pair.

The table address is determined by the contents of the program counter present when this instruction is executed.

The table area must have necessary data loaded by an assembler pseudo instruction (DB instruction).

The program counter is not affected by the execution of this instruction.

Caution **As with MOVT XA,@PCDE, when the instruction is located at address xxFFH, table data in the next page is transferred.**

MOV_T XA,@BCDE

Function: XA ← ROM (B₂₋₀+CDE)

Transfers the low-order four bits of the table data (eight bits) in program memory to the A register, and the high-order four bits to the X register. The table data is addressed by the low-order three bits of the B register and the contents of the C, D, and E registers.

The table area must have necessary data loaded by an assembler pseudo instruction (DB instruction). The program counter is not affected by the execution of this instruction.

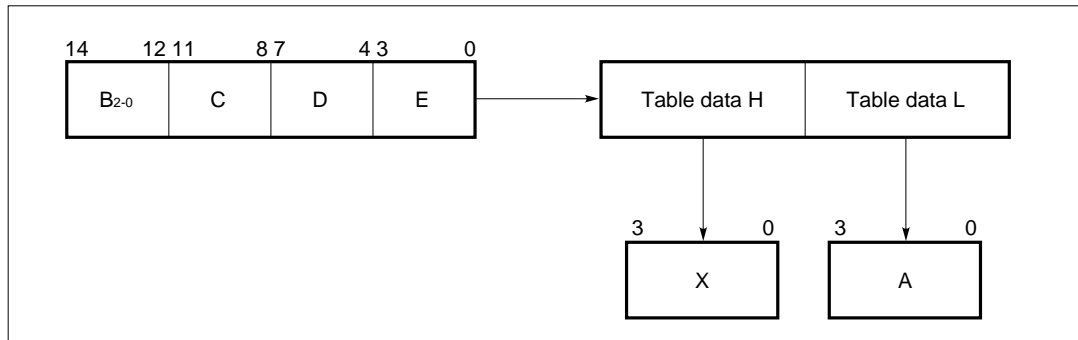

MOV_T XA,@BCXA

Function: XA ← ROM (B₂₋₀+CXA)

Transfers the low-order four bits of the table data (eight bits) in program memory to the A register, and the high-order four bits to the X register. The table data is addressed by the low-order three bits of the B register and the contents of the C, X, and A registers.

The table area must have necessary data loaded by an assembler pseudo instruction (DB instruction). The program counter is not affected by the execution of this instruction.

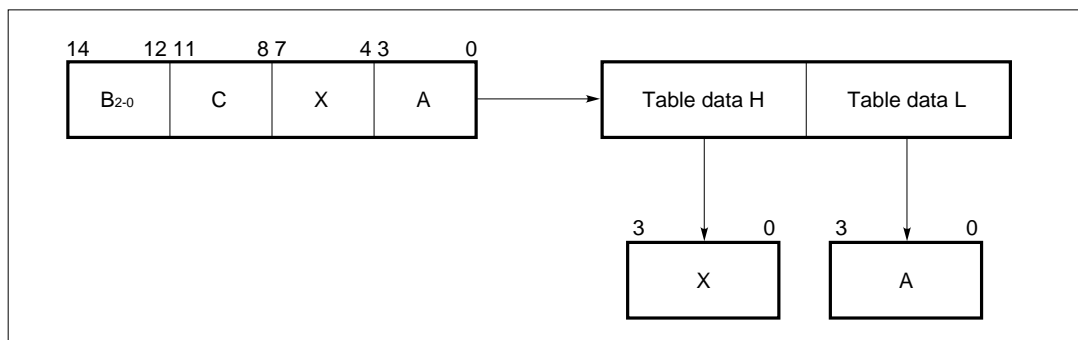

10.4.3 Bit Transfer Instructions

MOV1 CY,fmem.bit
MOV1 CY,pmem.@L
MOV1 CY,@H+mem.bit

Function: CY <- (bit specified in operand)

Transfers the data memory bit specified by bit manipulation addressing (fmem.bit, pmem.@L, @H+mem.bit) to the carry flag (CY).

MOV1 fmem.bit,CY
MOV1 pmem.@L,CY
MOV1 @H+mem.bit,CY

Function: (bit specified in operand) <- CY

Transfers the carry flag bit to the data memory bit specified by bit manipulation addressing (fmem.bit, pmem.@L, @H+mem.bit)

Example

The flag (bit 3 at address 3FH) in data memory is set in bit 2 of port 3.

```
FLAG EQU 3FH.3
SEL MB0
MOV H,#FLAG SHR 6 ; H <- high-order 4 bits of FLAG
MOV1 CY,@H+FLAG ; CY <- FLAG
MOV1 PORT3.2,CY ; P32 <- CY
```

10.4.4 Arithmetic/Logical Instructions

ADDS A,#n4

Function: $A \leftarrow A+n4$; Skip if carry. $n4 = I_{3-0}$: 0-FH

Adds the 4-bit immediate data $n4$ to the contents of the A register in binary, then skips the next instruction if the addition generates a carry. The carry flag is not affected.

This instruction, when combined with the ADDC A,@HL or SUBC A,@HL instruction, functions as a number system conversion instruction. (See **Section 10.1.4.**)

ADDS XA,#n8

Function: $XA \leftarrow XA+n8$; Skip if carry. $n8 = I_{7-0}$: 00H-FFH

Adds the 8-bit immediate data $n8$ to the contents of the XA register pair in binary, then skips the next instruction if the addition generates a carry. The carry flag is not affected.

ADDS A,@HL

Function: $A \leftarrow A+(HL)$; Skip if carry.

Adds the data at the data memory location addressed by the HL register pair to the contents of the A register in binary, then skips the next instruction if the addition generates a carry. The carry flag is not affected.

ADDS XA,rp'

Function: $XA \leftarrow XA+rp'$; Skip if carry.

Adds the contents of register pair rp' (XA, HL, DE, BC, XA', HL', DE', BC') to the contents of the XA register pair in binary, then skips the next instruction if the addition generates a carry. The carry flag is not affected.

ADDS rp'1,XA

Function: $rp' \leftarrow rp'+XA$; Skip if carry.

Adds the contents of the XA register pair to the contents of register pair $rp'1$ (HL, DE, BC, XA', HL', DE', BC') in binary, then skips the next instruction if the addition generates a carry. The carry flag is not affected.

Example

The register pair is left-shifted.

```
MOV    XA,rp'1
ADDS   rp'1,XA
NOP
```

ADDC A,@HL

Function: $A,CY \leftarrow A+(HL)+CY$

Adds the data at the data memory location addressed by the HL register pair together with the carry flag to the contents of the A register in binary. If the addition generates a carry, the carry flag is set. If no carry is generated, the carry flag is reset.

If the execution of this instruction generates a carry when this instruction is immediately followed by the ADDS A,#n4 instruction, the ADDS A,#n4 instruction is skipped. If no carry is generated, the ADDS A,#n4 instruction is executed, and the skip function of the ADDS A,#n4 instruction is disabled. Accordingly, a combination of these instructions can be used for number system conversion. (See **Section 10.1.4.**)

ADDC XA,rp'

Function: $XA,CY \leftarrow XA+rp'+CY$

Adds the contents of register pair rp' (XA, HL, DE, BC, XA', HL', DE', BC') together with the carry flag to the contents of the XA register pair in binary. If the addition generates a carry, the carry flag is set. If no carry is generated, the carry flag is reset.

ADDC rp'1,XA

Function: $rp'1,CY \leftarrow rp'1+XA+CY$

Adds the contents of the XA register pair together with the carry flag to the contents of register pair rp'1 (HL, DE, BC, XA', HL', DE', BC') in binary. If the addition generates a carry, the carry flag is set. If no carry is generated, the carry flag is reset.

SUBS A,@HL

Function: $A \leftarrow A-(HL)$; Skip if borrow

Subtracts the data at the data memory location addressed by the HL register pair from the contents of the A register, then sets the result in the A register. If the subtraction generates a borrow, the immediately following instruction is skipped.

The carry flag is not affected.

SUBS XA,rp'

Function: $XA \leftarrow XA - rp'$; Skip if borrow

Subtracts the contents of register pair rp' (XA, HL, DE, BC, XA', HL', DE', BC') from the contents of the XA register pair, then sets the result in the XA register pair. If the subtraction generates a borrow, the immediately following instruction is skipped.

The carry flag is not affected.

Example

Data memory is compared with register pair rp' .

```
MOV    XA,mem
SUBS   XA,rp'
                                ; (mem) ≥ rp'
                                ; (mem) < rp'
```

SUBS rp'1,XA

Function: $rp'1 \leftarrow rp'1 - XA$; Skip if borrow

Subtracts the contents of the XA register pair from the contents of register pair $rp'1$ (HL, DE, BC, XA', HL', DE', BC'), then sets the result in register pair $rp'1$. If the subtraction generates a borrow, the immediately following instruction is skipped.

The carry flag is not affected.

SUBC A,@HL

Function: $A, CY \leftarrow A - (HL) - CY$

Subtracts the data at the data memory location addressed by the HL register pair together with the carry flag from the contents of the A register, then sets the result in the A register. If the subtraction generates a borrow, the carry flag is set. If no borrow is generated, the carry flag is reset.

If the execution of this instruction generates no borrow when this instruction is followed by the ADDS A,#n4 instruction, the ADDS A,#n4 instruction is skipped. If a borrow is generated, the ADDS A,#n4 instruction is executed, and the skip function of the ADDS A,#n4 instruction is disabled. Accordingly, a combination of these instructions can be used for number system conversion. (See **Section 10.1.4.**)

SUBC XA,rp'

Function: $XA, CY \leftarrow XA - rp' - CY$

Subtracts the contents of register pair rp' (XA, HL, DE, BC, XA', HL', DE', BC') together with the carry flag from the contents of the XA register pair, then sets the result in the XA register pair. If the subtraction generates a borrow, the carry flag is set. If no borrow is generated, the carry flag is reset.

SUBC rp'1,XA

Function: $rp'1, CY \leftarrow rp'1 - XA - CY$

Subtracts the contents of the XA register pair together with the carry flag from the contents of register pair rp'1 (HL, DE, BC, XA', HL', DE', BC'), then sets the result in register pair rp'1. If the subtraction generates a borrow, the carry flag is set. If no borrow is generated, the carry flag is reset.

AND A,#n4

Function: $A \leftarrow A \wedge n4$ $n4 = I_{3-0}$: 0-FH

ANDs the contents of the A register with the 4-bit immediate data n4, then sets the result in the A register.

Example

The high-order two bits of an accumulator are set to 0.

```
AND A,#0011B
```

AND A,@HL

Function: $A \leftarrow A \wedge (HL)$

ANDs the contents of the A register with the data at the data memory location addressed by the HL register pair, then sets the result in the A register.

AND XA,rp'

Function: $XA \leftarrow XA \wedge rp'$

ANDs the contents of the XA register pair with the contents of register pair rp' (XA, HL, DE, BC, XA', HL', DE', BC'), then sets the result in the XA register pair.

AND rp'1,XA

Function: $rp'1 \leftarrow rp'1 \wedge XA$

ANDs the contents of register pair rp'1 (HL, DE, BC, XA', HL', DE', BC') with the contents of the XA register pair, then sets the result in the specified register pair.

OR A,#n4

Function: $A \leftarrow A \vee n4$ $n4 = I_{3-0}$: 0-FH

ORs the contents of the A register with the 4-bit immediate data n4, then sets the result in the A register.

Example

The low-order three bits of an accumulator are set to 1.

```
OR A,#0111B
```

OR A,@HL**Function:** $A \leftarrow A \vee (HL)$

ORs the contents of the A register with the data at the data memory location addressed by the HL register pair, then sets the result in the A register.

OR XA,rp'**Function:** $XA \leftarrow XA \vee rp'$

ORs the contents of the XA register pair with the contents of register pair rp' (XA, HL, DE, BC, XA', HL', DE', BC'), then sets the result in the XA register pair.

OR rp'1,XA**Function:** $rp'1 \leftarrow rp'1 \vee XA$

ORs the contents of register pair rp'1 (HL, DE, BC, XA', HL', DE', BC') with the contents of the XA register pair, then sets the result in register pair rp'1.

XOR A,#n4**Function:** $A \leftarrow A \vee n4$ n4 = I₃₋₀: 0-FH

Exclusive-ORs the contents of the A register with the 4-bit immediate data n4, then sets the result in the A register.

Example

The high-order bit of an accumulator is inverted.

```
XOR A,#1000B
```

XOR A,@HL**Function:** $A \leftarrow A \vee (HL)$

Exclusive-ORs the contents of the A register with the data at the data memory location addressed by the HL register pair, then sets the result in the A register.

XOR XA,rp'**Function:** $XA \leftarrow XA \vee rp'$

Exclusive-ORs the contents of the XA register pair with the contents of register pair rp' (XA, HL, DE, BC, XA', HL', DE', BC'), then sets the result in the XA register pair.

XOR rp'1,XA**Function:** $rp'1 \leftarrow rp'1 \vee XA$

Exclusive-ORs the contents of register pair rp'1 (HL, DE, BC, XA', HL', DE', BC') with the contents of the XA register pair, then sets the result in register pair rp'1.

10.4.5 Accumulator Manipulation Instructions

RORC A

Function: $CY \leftarrow A_0, A_{n-1} \leftarrow A_n, A_3 \leftarrow CY$ ($n = 1-3$)

Rotates the contents of the A register (4-bit accumulator) through the carry flag one bit position to the right.

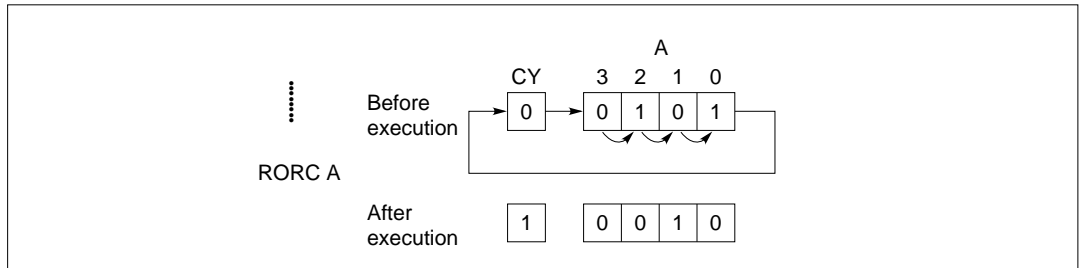

NOT A

Function: $A \leftarrow \bar{A}$

Obtains the one's complement of the A register (4-bit accumulator), that is, inverts each bit of the A register.

10.4.6 Increment/Decrement Instructions

INCS reg

Function: $reg \leftarrow reg+1$; Skip if $reg = 0$

Increments the contents of register reg (X, A, H, L, D, E, B, C). If the result of increment produces $reg = 0$, the immediately following instruction is skipped.

INCS rp1

Function: $rp1 \leftarrow rp1+1$; Skip if $rp1 = 00H$

Increments the contents of register pair rp1 (HL, DE, BC). If the result of increment produces $rp1 = 00H$, the immediately following instruction is skipped.

INCS @HL

Function: $(HL) \leftarrow (HL)+1$; Skip if $(HL) = 0$

Increments the data at the data memory location addressed by the HL register pair. If the result of increment produces data that is 0, the immediately following instruction is skipped.

INCS mem

Function: (mem) <- (mem)+1 ; Skip if (mem) = 0, mem = D₇₋₀: 00H-FFH

Increments the data at the data memory location addressed by the 8-bit immediate data mem. If the result of increment produces data that is 0, the immediately following instruction is skipped.

DECS reg

Function: reg <- reg-1 ; Skip if reg = FH

Decrements the contents of register reg (X, A, H, L, D, E, B, C). If the result of decrement produces reg = FH, the immediately following instruction is skipped.

DECS rp'

Function: rp' <- rp'-1 ; Skip if rp' = FFH

Decrements the contents of register pair rp' (XA, HL, DE, BC, XA', HL', DE', BC'). If the result of decrement produces rp' = FFH, the immediately following instruction is skipped.

10.4.7 Compare Instructions**SKE reg,#n4**

Function: Skip if reg = n4 n4 = I₃₋₀: 0-FH

Skips the immediately following instruction if the contents of register reg (X, A, H, L, D, E, B, C) match the 4-bit immediate data n4.

SKE @HL,#n4

Function: Skip if (HL) = n4 n4 = I₃₋₀: 0-FH

Skips the immediately following instruction if the data at the data memory location addressed by the HL register pair match the 4-bit immediate data n4.

SKE A,@HL

Function: Skip if A = (HL)

Skips the immediately following instruction if the contents of the A register match the data at the data memory location addressed by the HL register pair.

SKE XA,@HL

Function: Skip if A = (HL) and X = (HL+1)

Skips the immediately following instruction if the contents of the A register match the data at the data memory location addressed by the HL register pair, and the contents of the X register match the data at the next address in data memory.

However, if the contents of the L register are odd-numbered, an address with the lowest-order bit ignored is specified.

SKE A,reg

Function: Skip if A = reg

Skips the immediately following instruction if the contents of the A register match the contents of register reg (X, A, H, L, D, E, B, C).

SKE XA,rp'

Function: Skip if XA = rp'

Skips the immediately following instruction if the contents of the XA register pair match the contents of register pair rp' (XA, HL, DE, BC, XA', HL', DE', BC').

10.4.8 Carry Flag Manipulation Instructions**SET1 CY**

Function: CY <- 1

Sets the carry flag.

CLR1 CY

Function: CY <- 0

Clears the carry flag.

SKT CY

Function: Skip if CY = 1

Skips the immediately following instruction if the carry flag is set to 1.

NOT1 CY

Function: CY <- $\overline{\text{CY}}$

Inverts the carry flag. If it is 0, it is set to 1, or vice versa.

10.4.9 Memory Bit Manipulation Instructions

SET1 mem.bit

Function: (mem.bit) <- 1 mem = D₇₋₀: 00H-FFH, bit = B₁₋₀: 0–3

Sets the bit specified by the 2-bit immediate data bit at the address specified by the 8-bit immediate data mem.

SET1 fmem.bit

SET1 pmem.@L

SET1 @H+mem.bit

Function: (Bit specified in operand) <- 1

Sets the bit in data memory specified by bit manipulation addressing (fmem.bit, pmem.@L, @H+mem.bit).

CLR1 mem.bit

Function: (mem.bit) <- 0 mem = D₇₋₀: 00H-FFH, bit = B₁₋₀: 0–3

Clears the bit specified by the 2-bit immediate data bit at the address specified by the 8-bit immediate data mem.

CLR1 fmem.bit

CLR1 pmem.@L

CLR1 @H+mem.bit

Function: (Bit specified in operand) <- 0

Clears the bit in data memory specified by bit manipulation addressing (fmem.bit, pmem.@L, @H+mem.bit).

SKT mem.bit

Function: Skip if (mem.bit) = 1

mem = D₇₋₀: 00H-FFH, bit = B₁₋₀: 0–3

Skips the immediately following instruction if the bit specified by the 2-bit immediate data bit at the address specified by the 8-bit immediate data mem is 1.

SKT fmem.bit

SKT pmem.@L

SKT @H+mem.bit

Function: Skip if (bit specified in operand) = 1

Skips the immediately following instruction if the bit in data memory specified by bit manipulation addressing (fmem.bit, pmem.@L, @H+mem.bit) is set to 1.

SKF mem.bit

Function: Skip if (mem.bit) = 0

mem = D₇₋₀: 00H-FFH, bit = B₁₋₀: 0-3

Skips the immediately following instruction if the bit specified by the 2-bit immediate data bit at the address specified by the 8-bit immediate data mem is 0.

SKF fmem.bit**SKF pmem.@L****SKF @H+mem.bit**

Function: Skip if (bit specified in operand) = 0

Skips the immediately following instruction if the bit in data memory specified by bit manipulation addressing (fmem.bit, pmem.@L, @H+mem.bit) is 0.

SKTCLR fmem.bit**SKTCLR pmem.@L****SKTCLR @H+mem.bit**

Function: Skip if (bit specified in operand) = 1 then clear

Skips the immediately following instruction if the bit in data memory specified by bit manipulation addressing (fmem.bit, pmem.@L, @H+mem.bit) is 1, then clears the bit to 0.

AND1 CY,fmem.bit**AND1 CY,pmem.@L****AND1 CY,@H+mem.bit**

Function: CY <- CY ∧ (bit specified in operand)

ANDs the content of the carry flag with the bit in data memory specified by bit manipulation addressing (fmem.bit, pmem.@L, @H+mem.bit), then sets the result in the carry flag.

OR1 CY,fmem.bit**OR1 CY,pmem.@L****OR1 CY,@H+mem.bit**

Function: CY <- CY ∨ (bit specified in operand)

ORs the content of the carry flag with the bit in data memory specified by bit manipulation addressing (fmem.bit, pmem.@L, @H+mem.bit), then sets the result in the carry flag.

XOR1 CY,fmem.bit
XOR1 CY,pmem.@L
XOR1 CY,@H+mem.bit

Function: $CY \leftarrow CY \nabla$ (bit specified in operand)

Exclusive-ORs the content of the carry flag with the bit in data memory specified by bit manipulation addressing (fmem.bit, pmem.@L, @H+mem.bit), then sets the result in the carry flag.

10.4.10 Branch Instructions

BR addr1

Function: $PC_{14-0} \leftarrow addr1$

$addr1 = 0000H-5F7FH$ ($\mu PD75517$)

$0000H-7F7FH$ ($\mu PD75518, \mu PD75P518$)

Branches to the address specified by the 15-bit immediate data addr1.

This instruction is an assembler pseudo instruction, and the assembler automatically replaces this instruction with the BR !addr instruction, BRA !addr1 instruction, BRCB !caddr instruction, or BR \$addr instruction as required at assembly time.

BR !addr

Function: $PC_{14-0} \leftarrow PC_{13-0} \leftarrow !addr$

$addr = 0000H-3FFFH$

Transfers the 14-bit immediate data addr to the program counter (PC), then branches to the location addressed by the program counter. A branch can occur to any location in the 16K-byte program memory space (0000H to 3FFFH).

BR \$addr

Function: $PC_{14-0} \leftarrow addr$

$addr = (PC - 15) \text{ to } (PC - 1), (PC + 2) \text{ to } (PC + 16)$

Relative branch instruction with branch ranges of (-15 to -1) and (+2 to +16) from the current address. The instruction is not affected by page or block boundaries.

BR PCDE

Function: $PC_{14-8} \leftarrow PC_{14-8}$, $PC_{7-4} \leftarrow D$, $PC_{3-0} \leftarrow E$

Branches to the address specified by the program counter whose low-order 8 bits (PC_{7-0}) have been replaced with the contents of the DE register pair. The high-order bits of the program counter are not affected.

Caution **The BR PCDE instruction usually causes a branch within the page containing the instruction. However, if the first byte of the instruction code is located at address `xxFEH` or `xxFFH`, a branch to the next page instead of that page occurs.**

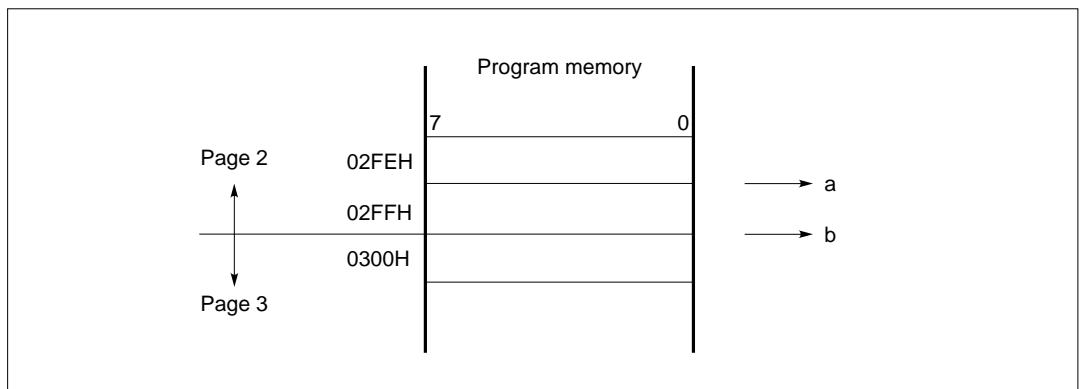

If the BR PCDE instruction is located at a or b in the figure above, a branch to page 3 instead of page 2 occurs, jumping to the low-order 8 bits of the address specified by the contents of the DE register pair.

BR PCXA

Function: $PC_{7-4} \leftarrow X$, $PC_{3-0} \leftarrow A$

Branches to the address specified by the program counter whose low-order 8 bits (PC_{7-0}) have been replaced with the contents of the XA register pair. The high-order bits of the program counter are not affected.

Caution **As with the BR PCDE instruction, if the first byte is located at address `xxFEH` or `xxFFH`, a branch to the next page instead of the page containing the instruction occurs.**

BR BCDE

Function: $PC_{14-0} \leftarrow B_{2-0} + CDE$

Branches to the address specified by the program counter whose bits have been replaced with the contents of the B₂₋₀, C, D, and E registers.

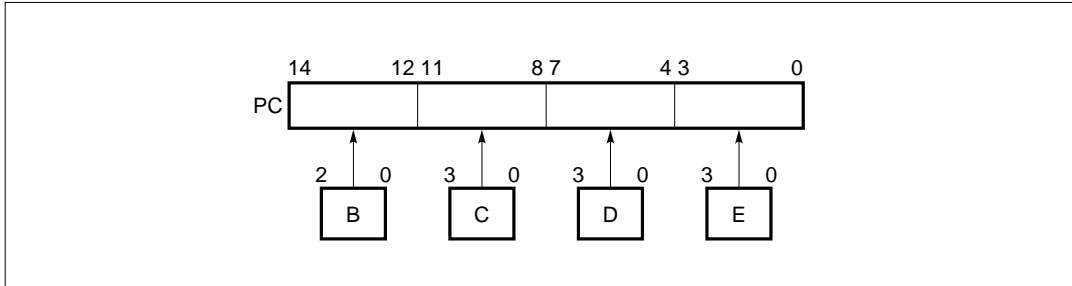

BR BCXA

Function: $PC_{14-0} \leftarrow B_{2-0} + CXA$

Branches to the address specified by the program counter whose bits have been replaced with the contents of the B₂₋₀, C, X, and A registers.

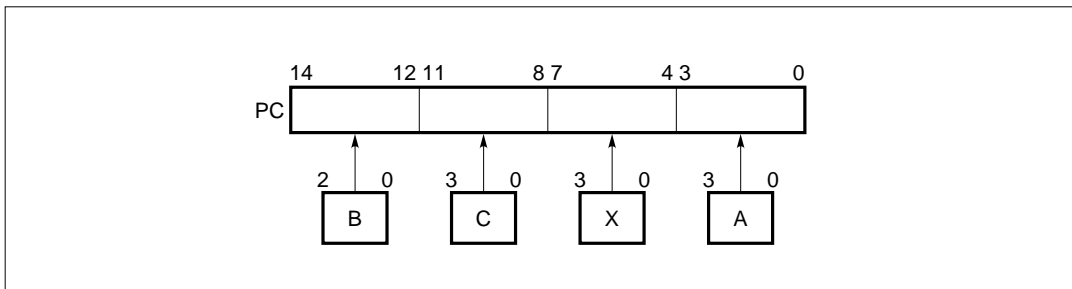

BRA !addr1

Function: $PC_{14-0} \leftarrow !addr1$ $addr1 = 0000H-5F7FH$ ($\mu PD75517$)

$0000H-7F7FH$ ($\mu PD75P518$)

Transfers the 15-bit immediate data addr1 to the program counter, then branches to the location addressed by the program counter. A branch can occur to any location in the entire program memory space.

BRCB !caddr

Function: $PC_{14-0} \leftarrow PC_{14,13,12} + caddr_{11-0}$

$caddr = n000H - nFFFH$

$n = PC_{14,13,12} = 0-7$

Branches to the address specified by the program counter whose low-order 12 bits (PC_{11-0}) have been replaced with the 12-bit immediate data $caddr$.

Caution **The BRCB !caddr instruction usually causes a branch within the block containing the instruction. However, if the first byte is located at address 0FFEh or 0FFFh, a branch to block 1 instead of block 0 occurs.**

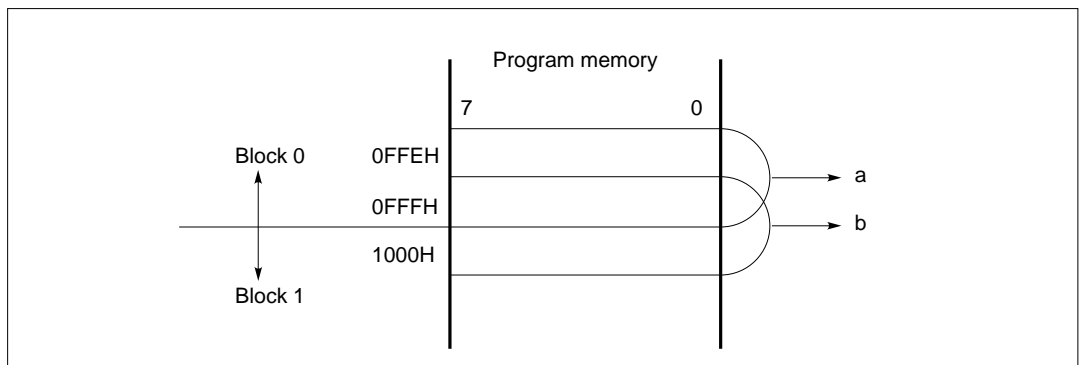

If the BRCB !caddr instruction is located at a or b in the figure above, a branch to block 1 instead of block 0 occurs.

TBR addr

Function:

Assembler pseudo instruction of the GETI instruction for table definition. This instruction is used to replace a 3-byte BR !addr instruction with a 1-byte GETI instruction. The 12-bit address data must be coded in $addr$. For detailed information, refer to **RA75X Assembler Package User's Manual: Language**.

$addr = 0000H - 3FFFH$

10.4.11 Subroutine Stack Control Instructions

CALL !addr

Function: (SP-2) <- x, x, MBE, RBE
(SP-3) <- PC₇₋₄, (SP-4) <- PC₃₋₀
(SP-5) <- 0, PC₁₄, PC₁₃, PC₁₂
(SP-6) <- PC₁₁₋₈
PC₁₄ <- 0, PC₁₃₋₀ <- addr, SP <- SP-6
addr = 0000H-3F7FH

CALLA !addr1

Function: (SP-2) <- x, x, MBE, RBE
(SP-3) <- PC₇₋₄, (SP-4) <- PC₃₋₀
(SP-5) <- 0, PC₁₄, PC₁₃, PC₁₂
(SP-6) <- PC₁₁₋₈
PC₁₄₋₀ <- addr1, SP <- SP-6

Saves the contents of the program counter (return address), MBE, and RBE to the data memory location (stack) addressed by the stack pointer (SP), then branches to the location addressed by the 14-bit immediate data addr after decrementing the stack pointer.

CALLF !faddr

Function: (SP-2) <- x, x, MBE, RBE
(SP-3) <- PC₇₋₄, (SP-4) <- PC₃₋₀
(SP-5) <- 0, PC₁₄, PC₁₃, PC₁₂
(SP-6) <- PC₁₁₋₈
SP <- SP-6
PC₁₄₋₀ <- 0000+faddr

faddr = 0000H-07FFH

Saves the contents of the program counter (PC; Return address), MBE, and RBE to the data memory location (stack) addressed by the stack pointer, then branches to the location addressed by the 11-bit immediate data faddr after decrementing the stack pointer. Only the address range 0000H-07FFH (0-2047) can be called.

TCALL addr

Function:

Assembler pseudo instruction of the GETI instruction for table definition. This instruction is used to replace a 3-byte CALL !addr instruction with a 1-byte GETI instruction. The 12-bit address data must be coded in addr. For detailed information, refer to **RA75X Assembler Package User's Manual: Language**.

addr = 0000H-3FFFH

RET

Function: $PC_{11-8} \leftarrow (SP), x, PC_{14}, PC_{13}, PC_{12} \leftarrow (SP+1)$

$PC_{3-0} \leftarrow (SP+2), PC_{7-4} \leftarrow (SP+3)$

$x, x, MBE, RBE \leftarrow (SP+4)$

$SP \leftarrow SP+6$

Restores the program counter, MBE, and RBE with the data at the data memory location (stack) addressed by the stack pointer, then increments the contents of the stack pointer.

Caution **The program status word is not restored except MBE and RBE.**

RETS

Function: $PC_{11-8} \leftarrow (SP), x, PC_{14}, PC_{13}, PC_{12} \leftarrow (SP+1)$

$PC_{3-0} \leftarrow (SP+2), PC_{7-4} \leftarrow (SP+3)$

$x, x, MBE, RBE \leftarrow (SP+4)$

$SP \leftarrow SP+6$

Then skip unconditionally

Restores the program counter, MBE, and RBE with the data at the data memory location (stack) addressed by the stack pointer, then skips unconditionally after incrementing the contents of the stack pointer.

Caution **The program status word is not restored except MBE and RBE.**

RETI

Function: $PC_{11-8} \leftarrow (SP), X, PC_{14}, PC_{13}, PC_{12} \leftarrow (SP+1)$

$PC_{3-0} \leftarrow (SP+2), PC_{7-4} \leftarrow (SP+3)$

$PSW_L \leftarrow (SP+4), PSW_H \leftarrow (SP+5),$

$SP \leftarrow SP+6,$

Restores the program counter and program status word (PSW) with the data at the data memory location (stack) addressed by the stack pointer, then increments the contents of the stack pointer.

This instruction is used when control is returned from an interrupt service routine.

PUSH rp

Function: $(SP-1) \leftarrow rp_H, (SP-2) \leftarrow rp_L, SP \leftarrow SP-2$

Saves the contents of register pair rp (XA, HL, DE, BC) to the data memory location (stack) addressed by the stack pointer, then decrements the stack pointer.

The high-order part of a register pair (rp_H : X, H, D, B) is saved to the stack location addressed by $(SP-1)$, and the low-order part (rp_L : A, L, E, C) is saved to the stack location addressed by $(SP-2)$.

PUSH BS

Function: $(SP-1) \leftarrow MBS, (SP-2) \leftarrow RBS, SP \leftarrow SP-2$

Saves the contents of the memory bank select register (MBS) and the register bank select register (RBS) to the data memory location (stack) addressed by the stack pointer, then decrements the stack pointer.

POP rp

Function: $rp_L \leftarrow (SP), rp_H \leftarrow (SP+1), SP \leftarrow SP+2$

Restores register pair rp (XA, HL, DE, BC) with the data at the data memory location (stack) addressed by the stack pointer, then increments the stack pointer.

The low-order part of a register pair (rp_L : A, L, E, C) is restored from the contents of (SP) , and the high-order part (rp_H : X, H, D, B) is restored with the contents of $(SP+1)$.

POP BS

Function: $RBS \leftarrow (SP), MBS \leftarrow (SP+1), SP \leftarrow SP+2$

Restores the register bank select register (RBS) and the memory bank select register (MBS) with the data at the data memory location (stack) addressed by the stack pointer, then increments the stack pointer.

10.4.12 Interrupt Control Instructions

EI

Function: IME (IPS.3) \leftarrow 1

Sets the interrupt master enable flag (bit 3 of the interrupt priority specification register) to 1 to enable interrupts. Whether to accept an interrupt is controlled with the corresponding interrupt enable flag.

EI IExxx

Function: IExxx \leftarrow 1 xxx = N₅, N₂₋₀

Sets an interrupt enable flag (IExxx) to 1 to enable an interrupt. (xxx = BT, CSIO, T0, W, TPG, 0, 1, 2, 4)

DI

Function: IME (IPS.3) \leftarrow 0

Resets the interrupt master enable flag (bit 3 of the interrupt priority specification register) to 0 to disable all interrupts regardless of the states of the interrupt enable flags.

DI IExxx

Function: IExxx \leftarrow 0 xxx = N₅, N₂₋₀

Resets an interrupt enable flag to 0 to disable an interrupt. (xxx = BT, CSIO, T0, W, TPG, 0, 1, 2, 4)

10.4.13 I/O Instructions

IN A,PORTn

Function: A \leftarrow PORTn n = N₃₋₀: 0–15

Transfers the contents of the port specified by PORTn (n = 0-15) to the A register.

Caution **Before this instruction can be executed, MBE = 0 or (MBE = 1, MBS = 15) must be set. A number from 0 to 15 can be specified as n. Depending on I/O mode specification, output latch data (in the output mode) or pin data (in the input mode) are transferred.**

IN XA,PORTn

Function: $A \leftarrow \text{PORTn}, X \leftarrow \text{PORTn+1}$ $n = N_{3-0}: 4, 6$

Transfers the contents of the port specified by PORTn ($n = 4$ or 6) to the A register, then transfers the contents of the next port to the X register.

Caution Only the number 4 or 6 can be specified as n. Before this instruction can be executed, MBE = 0 or (MBE = 1, MBS = 15) must be set. Depending on I/O mode specification, output latch data (in the output mode) or pin data (in the input mode) are transferred.

OUT PORTn,A

Function: $\text{PORTn} \leftarrow A$ $n = N_{3-0}: 2-7, 9-14$

Transfers the contents of the A register to the output latch of the port specified by PORTn ($n = 2-7, 9-14$).

Caution Before this instruction can be executed, MBE = 0 or (MBE = 1, MBS = 15) must be set. A number from 2 to 7 or 9 to 14 can be specified as n.

OUT PORTn,XA

Function: $\text{PORTn} \leftarrow A, \text{PORTn+1} \leftarrow X$ $n = N_{3-0}: 4, 6$

Transfers the contents of the A register to the output latch of the port specified by PORTn ($n = 4, 6$), then transfers the contents of the X register to the output latch of the next port.

Caution Before this instruction can be executed, MBE = 0 or (MBE = 1, MBS = 15) must be set. Only 4 or 6 can be specified as n.

10.4.14 CPU Control Instructions

HALT

Function: PCC.2 \leftarrow 1

Sets the HALT mode. (This instruction is used to set bit 2 of the processor clock control register.)

Caution **The instruction immediately following a HALT instruction must be a NOP instruction.**

STOP

Function: PCC.3 \leftarrow 1

Sets the STOP mode. (This instruction is used to set bit 3 of the processor clock control register.)

Caution **The instruction immediately following a STOP instruction must be a NOP instruction.**

NOP

Function:

Uses one machine cycle without performing an action.

10.4.15 Special Instructions

SEL RBn

Function: RBS \leftarrow n n = N₁₋₀: 0 to 3

Sets the 2-bit immediate data n in the register bank select register.

SEL MBn

Function: MBS \leftarrow n n = N₃₋₀: 0, 1, 2, 3, 15

Transfers the 4-bit immediate data n to the memory bank select register.

GETI taddr

Function: taddr = T₅₋₀, 0 : 20H-7FH

- When a table defined by the TBR instruction is referenced(**Note**)
 - PC₁₃₋₀ <- (taddr)₅₋₀ + (taddr+1),
 - PC₁₄ <- 0
- When a table defined by the TCALL instruction is referenced(**Note**)
 - (SP-2) <- x, x, MBE, RBE
 - (SP-3) <- PC₇₋₄, (SP-4) <- PC₃₋₀
 - (SP-5) <- x, PC₁₄₋₁₂, (SP-6) <- PC₁₁₋₈
 - PC₁₄ <- 0, PC₁₃₋₀ <- (taddr)₅₋₀ + (taddr+1)
 - SP <- SP-6
- When a table defined by an instruction other than the TBR or TCALL instruction is referenced
 - An instruction using (taddr) (taddr+1) as its operation code is executed.

(Note) Only addresses 0000H to 3FFFH can be specified by the TBR and TCALL instructions.

The 2-byte data at the program memory addresses specified by (taddr) and (taddr+1) is referenced and executed as an instruction.

Addresses 0020H to 007FH are used as a reference table area. Data must be written to this area beforehand. When a 1-byte instruction or 2-byte instruction is written, its mnemonic can be used directly.

For a 3-byte call instruction or 3-byte branch instruction, an assembler pseudo instruction (TCALL, TBR) is used.

Only an even address can be specified as taddr.

Caution All 2-byte instructions (except the BRCB instruction and CALLF instruction) set in the reference table must be 2-machine-cycle instructions. Pairs of 1-byte instructions can be set as indicated in the table below.

First byte instruction	Second byte instruction
MOV A,@HL MOV @HL,A XCH A,@HL	[INCS L DECS L [INCS H DECS H INCS HL
MOV A,@DE XCH A,@DE	[INCS E DECS E [INCS D DECS D INCS DE
MOV A,@DL XCH A,@DL	[INCS L DECS L [INCS D DECS D

The PC is not incremented during execution of a GETI instruction, so that after a reference instruction is executed, execution is resumed starting at the address immediately after the GETI instruction.

If the instruction immediately preceding a GETI instruction has the skip function, the GETI instruction is skipped as with other 1-byte instructions. If an instruction referenced with a GETI instruction has the skip function, the instruction immediately following the GETI instruction is skipped.

If a GETI instruction references an instruction having a string effect, the following processing is performed:

- If the instruction immediately preceding the GETI instruction also has the string effect in the same group, the execution of the GETI instruction cancels the string effect, and the referenced instruction is not skipped.
- If the instruction immediately following the GETI instruction also has the string effect of the same group, the string effect of the referenced instruction remains valid, and the next instruction is skipped.

Example

<pre> MOV HL,#00H MOV XA,#FFH CALL SUB1 BR SUB2 </pre>	are replaced with GETI instructions.
---	--------------------------------------

```

                ORG    20H
HL00          : MOV    HL,#00H
XAFF          : MOV    XA,#FFH
CSUB1         : TCALL  SUB1
BSUB2         : TBR    SUB2
                :
                :
                :
GETI HL00     ; MOV HL,#00H
                :
                :
                :
GETI BSUB2    ; BR  SUB2
                :
                :
                :
GETI CSUB1    ; CALL SUB1
                :
                :
                :
GETI XAFF     ; MOV XA,#FFH
    
```

Appendix A

Development Tools

The following tools are available for the development of μ PD75518-based systems.

Language processor

RA75X relocatable assembler	Host machine	OS	Distribution media	Part number (product name)
	PC-9800 series	MS-DOSTM Ver. 3.30 to Ver. 5.00A(Notes)	3.5-inch 2HD	5.25-inch 2HD
5.25-inch 2HD				μ S5A10RA75X
IBM PC/ATM	PC DOSTM (Ver. 3.1)	5.25-inch 2HC	μ S7B10RA75X	

*

Remark The RA75X relocatable assembler can run only on the host machine under the OS mentioned above.

Tools for writing into PROM

Hardware	PG-1500	A PROM programmer with which programs can be written into PROMs in a stand-alone mode or by remote control from a host machine, when connected with the accessory board and optional socket board. Products programmable with the PG-1500 include commonly-used PROMs (256K-bit to 4M-bit) and single chip microcomputers containing a PROM.			
	PA-75P516GF	A PROM programmer adapter for the μ PD75P516GF and μ PD75P518GF. This programmer is connected to the PG-1500.			
	PA-75P516K	A PROM programmer adapter for the μ PD75P516K and μ PD75P518K. This programmer is connected to the PG-1500.			
Software	PG-1500 controller	This program enables the host machine to control the PG-1500 controller under the serial interface and parallel interface.			
		Host machine	OS	Distribution media	Part number (product name)
		PC-9800 series	MS-DOS [Ver. 3.30 to Ver. 5.00A(Note)]	3.5-inch 2HD	μ S5A13PG1500
				5.25-inch 2HD	μ S5A10PG1500
		IBM PC/AT	PC DOS (Ver. 3.1)	5.25-inch 2HC	μ S7B10PG1500

*

*

(Note) MS-DOS versions 5.00 and 5.00A provide a task swap function. This function, however, cannot be used in these software packages.

Remark The PG-1500 controller can run only on the host machine under the OS mentioned above.

Tools for debugging

Hardware	IE-75000-R ^(Note 1)	The IE-75000-R is an in-circuit emulator to debug hardware and software when an application system using 75X series is developed. The IE-75000-R is used in combination with an emulation probe. This provision enables affective debugging when connected with the host machine and a PROM programmer.			
	IE-75000-R-EM	The IE-75000-R-EM is an emulation board for evaluating an application system using 75X series. The IE-75000-R-EM is used in combination with the IE-75000-R or IE-75001-R. The IE-75000-R contains the emulation board. *			
	E-75001-R	The IE-75001-R is an in-circuit emulator to debug hardware and software when an application system using 75X series is developed. The IE-75001-R is used in combination with an optional emulation board IE-75000-R-EM and an emulation probe. This provision enables effective debugging when connected with the host machine and a PROM programmer.			
	EP-75516GF-R	The EP-75516GF-R is an emulation probe for the μ PD75518. This probe is used in combination with the IE-75000-R or IE-75001-R.			
	EV-9200G-80	The EV-9200G-80 (80-pin conversion socket) is attached to support easy connection with the user system.			
Software	IE control program	This program enables the host machine to control the IE-75000-R or IE-75001-R under the RS-232-C and Centronics interfaces.			
		Host machine	OS	Distribution media	
		PC-9800 series	MS-DOS [Ver. 3.30 to Ver. 5.00A ^(Note 2)]	3.5-inch 2HD	Part number (product name) μ S5A13IE75X
		IBM PC/AT	PC DOS (Ver. 3.1)	5.25-inch 2HD	μ S5A10IE75X
			5.25-inch 2HC	μ S7B10IE75X	

(Note 1) Maintenance service only

(Note 2) MS-DOS versions 5.00 and 5.00A provide a task swap function. This function, however, cannot be used in these software packages. *

Remark The IE control program and the assembler can run only on the host machine under the OS mentioned above.

Development Tool Configuration

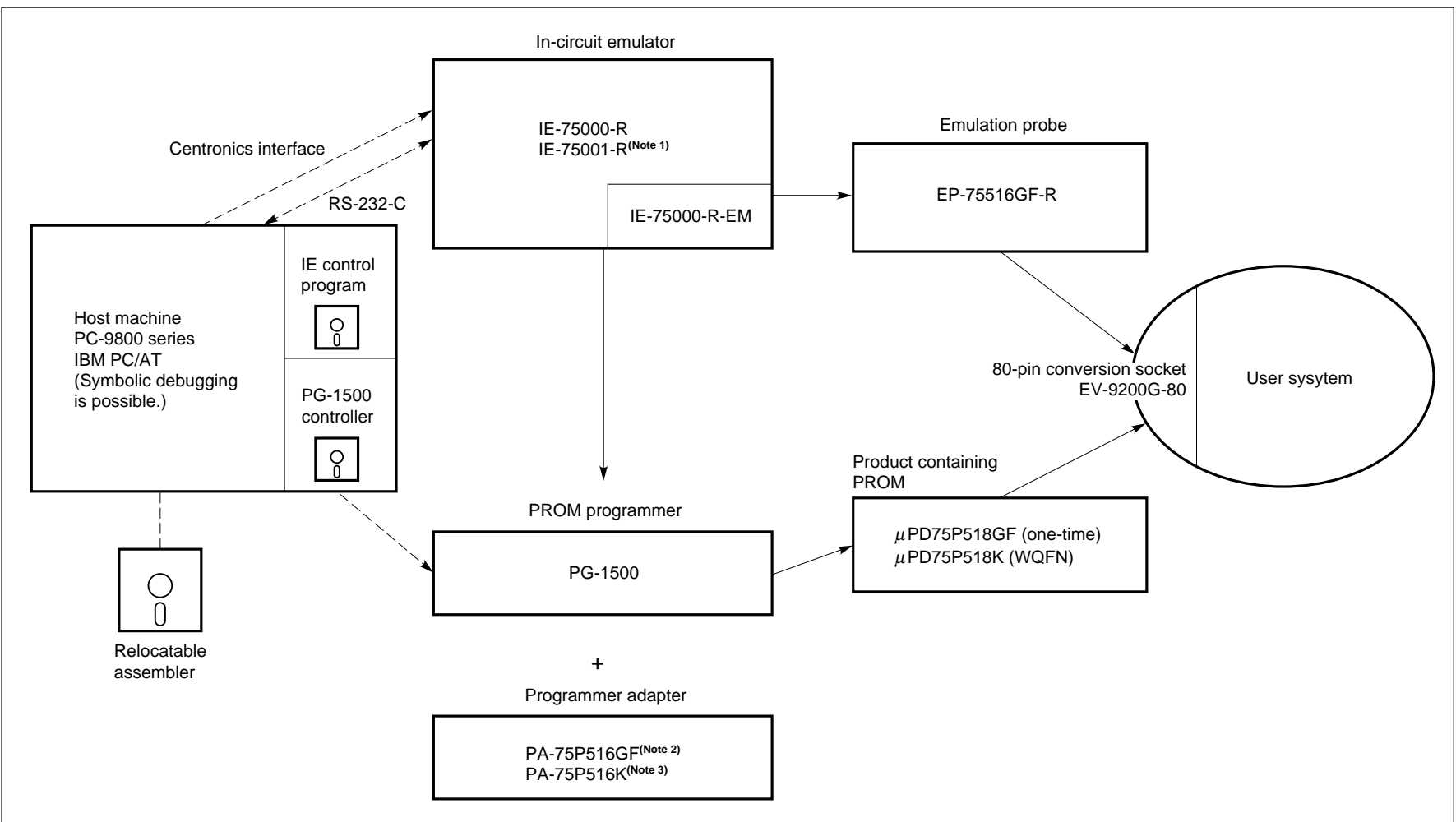

Phase-out/Discontinued

(Note 1)
 The IE-75001-R does not contain the IE-75000-R-EM (to be separately ordered).
 (Note 2)
 For the μPD75P518GF (one-time)
 (Note 3)
 For the μPD75P518K (WQFN)

Appendix B

Masked ROM Ordering Procedure

After program development for the μ PD75518 is completed, the masked ROM is ordered by the following procedure:

<1> **Advance notice of an order for masked ROM**

Give advance notice of masked ROM ordering to a special agent or NEC's Sales Department.

<2> **Preparation of media for ordering**

Use three UV-EPROMs having the same contents, or an 8-inch IBM format floppy disk in ordering a masked ROM. (For products with mask options, prepare a mask option information sheet describing the mask option data.)

<3> **Preparation of the required documents**

Prepare the following documents when ordering a masked ROM:

- Masked ROM order sheet
- Masked ROM order check sheet
- Mask option information sheet (for products with mask options)

<4> **Ordering**

Send a set of the media created in <2> and the documents created in <3> to a special agent or NEC's Sales Department by the date indicated in the advance notice.

[MEMO]

Appendix C *

Revision History

The revision history is shown below. The chapter numbers in the revised-chapter column indicate those of the corresponding edition.

Edition	Major changes	Revised chapter
Fifth	The figure, "Data Transmission from Slave Device to Master Device" has been modified.	Chapter 5
	A caution concerning the reduction of noise during A/D conversion has been modified.	
	The figure, "Analog Input Pin Connection" has been modified.	
	A caution concerning the standby mode has been added.	Chapter 7
	Descriptions of the IE-75001-R have been added.	Appendix A
Sixth	Documents related to the development tools and other documents have been added.	Preface
	A caution concerning the reliability of the μ PD75P518K has been added.	Preface and Chapter 1
	Descriptions of the stack bank selection register (SBS) and stack operation have been added to Section 1.1.	Chapter 1
	Section 1.3 has been added.	
	Descriptions of the STOP and HALT modes have been added to Sections 2.2.10 and 2.2.11.	Chapter 2
	The descriptions in Section 2.2.20 have been modified.	
	The recommended connections for IC and V_{PP} , listed in Table 2-3, have been modified.	
	Figures 5-3 and 5-4 have been modified.	Chapter 5
	A caution concerning the machine cycle has been added to Table 5-5.	
	Figure 5-38 has been modified.	
	The descriptions and figure in (4) of Section 5.6.4 have been modified. A caution has been added to (4) of Section 5.6.4.	
	The descriptions in (1) of Section 6.3 have been modified.	Chapter 6
	The sample programs given in Section 6.6 have been replaced.	

Edition	Major changes	Revised chapter
Sixth	Descriptions relating to the use of a crystal have been added to Section 7.2.	Chapter 7
	A caution has been added to Table 7-2.	
	The timing chart in (1) of Section 7.4 has been modified.	
	A caution concerning the switching system clock has been added to (2) of Section 7.4.	
	Table 8-1 has been modified.	Chapter 8
	Section 9.5 has been added.	Chapter 9
	The version of MS-DOS has been upgraded to 5.00A. Therefore, a caution concerning the upgrade has been added.	Appendix A

Appendix D

Instruction Index

D.1 Instruction Index (By Function)

[Transfer instructions]

MOV A,#n4 ... 10-24
 MOV reg1,#n4 ... 10-24
 MOV rp,#n8 ... 10-24
 MOV A,@rpa ... 10-25
 MOV XA,@HL ... 10-25
 MOV @HL,A ... 10-25
 MOV @HL,XA ... 10-25
 MOV A,mem ... 10-26
 MOV XA,mem ... 10-26
 MOV mem,A ... 10-26
 MOV mem,XA ... 10-26
 MOV A,reg ... 10-26
 MOV XA,rp' ... 10-26
 MOV reg1,A ... 10-27
 MOV rp'1,XA ... 10-27
 XCH A,@rpa ... 10-27
 XCH XA,@HL ... 10-27
 XCH A,mem ... 10-28
 XCH XA,mem ... 10-28
 XCH A,reg1 ... 10-28
 XCH XA,rp' ... 10-28

[Table reference instructions]

MOVT XA,@PCDE ... 10-29
 MOVT XA,@PCXA ... 10-31
 MOVT XA,@BCDE ... 10-32
 MOVT XA,@BCXA ... 10-32

[Bit transfer instructions]

MOV1 CY,mem.bit ... 10-33
 MOV1 CY,pmem.@L ... 10-33
 MOV1 CY,@H+mem.bit ... 10-33
 MOV1 mem.bit,CY ... 10-33
 MOV1 pmem.@L,CY ... 10-33
 MOV1 @H+mem.bit,CY ... 10-33

[Arithmetic/logical instructions]

ADDS A,#n4 ... 10-34
 ADDS XA,#n8 ... 10-34
 ADDS A,@HL ... 10-34
 ADDS XA,rp' ... 10-34
 ADDS rp'1,XA ... 10-34
 ADDC A,@HL ... 10-35
 ADDC XA,rp' ... 10-35
 ADDC rp'1,XA .. 10-35

SUBS	A,@HL ... 10-35	SKE	@HL,#n4 ... 10-40
SUBS	XA,rp' ... 10-36	SKE	A,@HL ... 10-40
SUBS	rp'1,XA ... 10-36	SKE	XA,@HL ... 10-41
SUBC	A,@HL ... 10-36	SKE	A,reg ... 10-41
SUBC	XA,rp' ... 10-36	SKE	XA,rp' ... 10-41
SUBC	rp'1,XA ... 10-37		
AND	A,#n4 ... 10-37	[Carry flag manipulation instructions]	
AND	A,@HL ... 10-37	SET1	CY ... 10-41
AND	XA,rp' ... 10-37	CLR1	CY ... 10-41
AND	rp'1,XA ... 10-37	SKT	CY ... 10-41
OR	A,#n4 ... 10-37	NOT1	CY ... 10-41
OR	A,@HL ... 10-38		
OR	XA,rp' ... 10-38	[Memory bit manipulation instructions]	
OR	rp'1,XA ... 10-38	SET1	mem.bit ... 10-42
XOR	A,#n4 ... 10-38	SET1	fmem.bit ... 10-42
XOR	A,@HL ... 10-38	SET1	pmem.@L ... 10-42
XOR	XA,rp' ... 10-38	SET1	@H+mem.bit ... 10-42
XOR	rp'1,XA ... 10-38	CLR1	mem.bit ... 10-42
		CLR1	fmem.bit ... 10-42
[Accumulator manipulation instructions]		CLR1	pmem.@L ... 10-42
RORC	A ... 10-39	CLR1	@H+mem.bit ... 10-42
NOT	A ... 10-39	SKT	mem.bit ... 10-42
		SKT	fmem.bit ... 10-42
[Increment/decrement instructions]		SKT	pmem.@L ... 10-42
INCS	reg ... 10-39	SKT	@H+mem.bit ... 10-42
INCS	rp1 ... 10-39	SKF	mem.bit ... 10-43
INCS	@HL ... 10-39	SKF	fmem.bit ... 10-43
INCS	mem ... 10-40	SKF	pmem.@L ... 10-43
DECS	reg ... 10-40	SKF	@H+mem.bit ... 10-43
DECS	rp' ... 10-40	SKTCLR	fmem.bit ... 10-43
		SKTCLR	pmem.@L ... 10-43
[Compare instructions]		SKTCLR	@H+mem.bit ... 10-43
SKE	reg,#n4 ... 10-40	AND1	CY,fmem.bit ... 10-43

AND1	CY,pmem.@L ... 10-43	[Interrupt control instructions]
AND1	CY,@H+mem.bit ... 10-43	EI ... 10-51
OR1	CY,fmem.bit ... 10-43	EI IExxx ... 10-51
OR1	CY,pmem.@L ... 10-43	DI ... 10-51
OR1	CY,@H+mem.bit ... 10-43	DI IExxx ... 10-51
XOR1	CY,fmem.bit ... 10-44	
XOR1	CY,pmem,@L ... 10-44	[I/O instructions]
XOR1	CY,@H+mem.bit ... 10-44	IN A,PORTn ... 10-51
		IN XA,PORTn ... 10-52
		OUT PORTn,A ... 10-52
		OUT PORTn,XA ... 10-52
		[CPU control instructions]
		HALT ... 10-53
		STOP ... 10-53
		NOP ... 10-53
		[Special instructions]
		SEL RBn ... 10-53
		SEL MBn ... 10-53
		GETI taddr ... 10-54
		[Subroutine stack control instructions]
CALL	!addr ... 10-48	
CALLA	!addr1 ... 10-48	
CALLF	!faddr ... 10-48	
TCALL	addr ... 10-49	
RET	... 10-49	
RETS	... 10-49	
RETI	... 10-50	
PUSH	rp ... 10-50	
PUSH	BS ... 10-50	
POP	rp ... 10-50	
POP	BS ... 10-50	

D.2 Instruction Index (Alphabetical Order)

[A]		CLR1	CY ... 10-41
ADDC	A,@HL ... 10-35	CLR1	fmem.bit ... 10-42
ADDC	rp'1,XA ... 10-35	CLR1	mem.bit ... 10-42
ADDC	XA,rp' ... 10-35	CLR1	pmem.@L ... 10-42
ADDS	A,#n4 ... 10-34	CLR1	@H+mem.bit ... 10-42
ADDS	A,@HL ... 10-34		
ADDS	rp'1,XA ... 10-34	[D]	
ADDS	XA,rp' ... 10-34	DECS	reg ... 10-40
ADDS	XA,#n8 ... 10-34	DECS	rp' ... 10-40
AND	A,#n4 ... 10-37	DI	... 10-51
AND	A,@HL ... 10-37	DI	IExxx ... 10-51
AND	rp'1,XA ... 10-37		
AND	XA,rp' ... 10-37	[E]	
AND1	CY,fmem.bit ... 10-43	EI	... 10-51
AND1	CY,pmem.@L ... 10-43	EI	IExxx ... 10-51
AND1	CY,@H+mem.bit ... 10-43		
[B]		[G]	
BR	addr1 ... 10-44	GETI	taddr ... 10-54
BR	BCDE ... 10-46	[H]	
BR	BCXA ... 10-46	HALT	... 10-53
BR	PCDE ... 10-45		
BR	PCXA ... 10-45	[I]	
BR	!addr ... 10-44	IN	A,PORTn ... 10-51
BR	\$addr ... 10-44	IN	XA,PORTn ... 10-52
BRA	!addr1 ... 10-46	INCS	mem ... 10-40
BRCB	!caddr ... 10-47	INCS	reg ... 10-39
[C]		INCS	rp1 ... 10-39
CALL	!addr ... 10-48	INCS	@HL ... 10-39
CALLA	!addr1 ... 10-48		
CALLF	!faddr ... 10-48		

[M]		[O]	
MOV	A,mem ... 10-26	OR	A,#n4 ... 10-37
MOV	A,reg ... 10-26	OR	A,@HL ... 10-38
MOV	A,#n4 ... 10-24	OR	rp'1,XA ... 10-38
MOV	A,@rpa ... 10-25	OR	XA,rp' ... 10-38
MOV	mem,A ... 10-26	OR1	CY,fmem.bit ... 10-43
MOV	mem,XA ... 10-26	OR1	CY,pmem.@L ... 10-43
MOV	reg1,A ... 10-24	OR1	CY,@H+mem.bit ... 10-43
MOV	reg1,#n4 ... 10-24	OUT	PORTn,A ... 10-52
MOV	rp,#n8 ... 10-24	OUT	PORTn,XA ... 10-52
MOV	rp'1,XA ... 10-27		
MOV	XA,mem ... 10-26	[P]	
MOV	XA,rp' ... 10-26	POP	BS ... 10-50
MOV	XA,@HL ... 10-25	POP	rp ... 10-50
MOV	@HL,A ... 10-25	PUSH	BS ... 10-50
MOV	@HL,XA ... 10-25	PUSH	rp ... 10-50
MOV1	CY,fmem.bit ... 10-33		
MOV1	CY,pmem.@L ... 10-33	[R]	
MOV1	CY,@H+mem.bit ... 10-33	RET	... 10-49
MOV1	fmem.bit,CY ... 10-33	RETI	... 10-50
MOV1	pmem.@L,CY ... 10-33	RETS	... 10-49
MOV1	@H+mem.bit,CY ... 10-33	RORC	A ... 10-39
MOVT	XA,@BCDE ... 10-32		
MOVT	XA,@BCXA ... 10-32	[S]	
MOVT	XA,@PCDE ... 10-29	SEL	MBn ... 10-53
MOVT	XA,@PCXA ... 10-31	SEL	RBn ... 10-53
		SET1	CY ... 10-41
[N]		SET1	fmem.bit ... 10-42
NOP	... 10-53	SET1	mem.bit ... 10-42
NOT	A ... 10-39	SET1	pmem.@L ... 10-42
NOT1	CY ... 10-41	SET1	@H+mem.bit ... 10-42
		SKE	A,reg ... 10-41
		SKE	A,@HL ... 10-40

SKE	reg,#n4 ...	10-40	XCH	XA,mem ...	10-28
SKE	XA,rp'	... 10-41	XCH	XA,rp'	... 10-28
SKE	XA,@HL	... 10-41	XOR	A,#n4	... 10-38
SKE	@HL,#n4	... 10-40	XOR	A,@HL	... 10-38
SKF	fmem.bit	... 10-43	XOR	rp'1,XA	... 10-38
SKF	mem.bit	... 10-43	XOR	XA,rp'	... 10-38
SKF	pmem.@L	... 10-43	XOR1	CY,fmem.bit	... 10-44
SKF	@H+mem.bit	... 10-43	XOR1	CY,pmem,@L	... 10-44
SKT	CY	... 10-41	XOR1	CY,@H+mem.bit	... 10-44
SKT	fmem.bit	... 10-42			
SKT	mem.bit	... 10-42			
SKT	pmem.@L	... 10-42			
SKT	@H+mem.bit	... 10-42			
SKTCLR	fmem.bit	... 10-43			
SKTCLR	pmem.@L	... 10-43			
SKTCLR	@H+mem.bit	... 10-43			
STOP	...	10-53			
SUBC	A,@HL	... 10-36			
SUBC	rp'1,XA	... 10-37			
SUBC	XA,rp'	... 10-36			
SUBS	A,@HL	... 10-35			
SUBS	rp'1,XA	... 10-36			
SUBS	XA,rp'	... 10-36			
[T]					
TBR	addr	... 10-47			
TCALL	addr	... 10-49			
[X]					
XCH	A,@rpa	... 10-27			
XCH	A,mem	... 10-28			
XCH	A,reg1	... 10-28			
XCH	XA,@HL	... 10-27			

Appendix E

Hardware Index

E.1 Hardware Index (Alphabetical Order with Respect to the Hardware Name)

[A]

Acknowledge detection flag ... 5-84
Acknowledge enable bit ... 5-84
Acknowledge trigger bit ... 5-84
A/D conversion mode register ... 5-153

[B]

Basic interval timer ... 5-38
Basic interval timer mode register ... 5-39
Bit sequential buffers ... 5-162
BT interrupt enable flag ... 6-5
BT interrupt request flag ... 6-5
Bus release detection flag ... 5-83
Bus release trigger bit ... 5-83
Busy enable bit ... 5-84

[C]

Carry flag ... 4-15
Clock output mode register ... 5-36
Command detection flag ... 5-83
Command trigger bit ... 5-83
Conversion completion detection flag ... 5-154

Conversion start direction bit ... 5-154

[E]

Edge detection mode register ... 6-10

[I]

Interrupt priority specification register ... 6-13
Interrupt status flag ... 4-16, 6-15
INT0 interrupt enable flag ... 6-5
INT1 interrupt enable flag ... 6-5
INT2 interrupt enable flag ... 6-5
INT4 interrupt enable flag ... 6-5
INT0 interrupt request flag ... 6-5
INT1 interrupt request flag ... 6-5
INT2 interrupt request flag ... 6-5
INT4 interrupt request flag ... 6-5

[M]

Memory bank enable flag ... 4-17
Memory bank select register ... 4-18

[P]

Port mode register group A ... 5-9

Port mode register group B ... 5-9

Port mode register group C ... 5-9

Port 0 to port 15 ... 5-1

Processor clock control register ... 5-24

Program counter ... 4-1

Program status word ... 4-14

Pull-up resistor specification register group A ... 5-17

[R]

Register bank enable flag ... 4-17

Register bank select register ... 4-18

[S]

SA register ... 5-155

Serial bus interface control register ... 5-82

Serial interface interrupt enable flag ... 6-5

Serial interface interrupt request flag ... 6-5

Serial interface operation enable/disable specification bit ... 5-80, 5-147

Serial operation mode register 0 ... 5-76

Serial operation mode register 1 ... 5-147

Serial transfer end flag ... 5-149

Shift register 0 ... 5-85

Shift register 1 ... 5-148

Signal from address comparator ... 5-80

Skip flag ... 4-16

Slave address register ... 5-87

Stack bank select register ... 4-11

Stack pointer ... 4-11

System clock control register ... 5-26

[T]

Timer/event counter count register ... 5-48

Timer/event counter interrupt enable flag ... 6-5

Timer/event counter interrupt request flag ... 6-5

Timer/event counter mode register ... 5-49

Timer/event counter modulo register ... 5-48

Timer/event counter output enable flag ... 5-51

Timer/pulse generator interrupt enable flag ... 6-5

Timer/pulse generator interrupt request flag ... 6-5

Timer/pulse generator modulo register ... 5-62

[W]

Wake-up function specification bit ... 5-80

Watch mode register ... 5-45

Watch timer interrupt enable flag ... 6-5

Watch timer interrupt request flag ... 6-5

E.2 Hardware Index (Alphabetical Order with Respect to the Hardware Symbol)

[A]

ACKD ... 5-84
ACKE ... 5-84
ACKT ... 5-84
ADM ... 5-153

[B]

BSB0-BSB3 ... 5-162
BSYE ... 5-84
BT ... 5-38
BTM ... 5-39

[C]

CLOM ... 5-36
CMDD ... 5-83
CMDT ... 5-83
COI ... 5-80
CSIE0 ... 5-80
CSIE1 ... 5-147
CSIM0 .. 5-78
CSIM1 ... 5-147
CY ... 4-15

[E]

EOC ... 5-154
EOT ... 5-149

[I]

IE0 ... 6-5
IE1 ... 6-5
IE2 ... 6-5

IE4 ... 6-5

IEBT ... 6-5

IECSI0 ... 6-5

IET0 ... 6-5

IETPG ... 6-5

IEW ... 6-5

IM0, IM1, IM2 ... 6-10

IPS ... 6-13

IRQ0 ... 6-5

IRQ1 ... 6-5

IRQ2 ... 6-5

IRQ4 ... 6-5

IRQBT ... 6-5

IRQCSI0 ... 6-5

IRQT0 ... 6-5

IRQTPG ... 6-5

IRQW ... 6-5

IST0, IST1 ... 4-16, 6-15

[M]

MBE ... 4-17

MBS ... 4-18

MODH, MODL ... 5-62

[P]

PC ... 4-1

PCC ... 5-24

PMGA ... 5-9

PMGB ... 5-9

PMGC ... 5-9

POGA ... 5-17

PORT0-PORT15 ... 5-1

PSW ... 4-14

[R]

RBE ... 4-17

RBS ... 4-18

RELD ... 5-83

RELT ... 5-83

[S]

SA ... 5-155

SBIC ... 5-82

SBS ... 4-11

SCC ... 5-26

SIO0 ... 5-85

SIO1 ... 5-148

SK0, SK1, SK2 ... 4-16

SOC ... 5-154

SP ... 4-11

SVA ... 5-87

[T]

T0 ... 5-48

TOE0 ... 5-51

TM0 ... 5-49

TMOD0 ... 5-48

[W]

WM ... 5-45

WUP ... 5-80