

To our customers,

Old Company Name in Catalogs and Other Documents

On April 1st, 2010, NEC Electronics Corporation merged with Renesas Technology Corporation, and Renesas Electronics Corporation took over all the business of both companies. Therefore, although the old company name remains in this document, it is a valid Renesas Electronics document. We appreciate your understanding.

Renesas Electronics website: <http://www.renesas.com>

April 1st, 2010
Renesas Electronics Corporation

Issued by: Renesas Electronics Corporation (<http://www.renesas.com>)

Send any inquiries to <http://www.renesas.com/inquiry>.

Notice

1. All information included in this document is current as of the date this document is issued. Such information, however, is subject to change without any prior notice. Before purchasing or using any Renesas Electronics products listed herein, please confirm the latest product information with a Renesas Electronics sales office. Also, please pay regular and careful attention to additional and different information to be disclosed by Renesas Electronics such as that disclosed through our website.
2. Renesas Electronics does not assume any liability for infringement of patents, copyrights, or other intellectual property rights of third parties by or arising from the use of Renesas Electronics products or technical information described in this document. No license, express, implied or otherwise, is granted hereby under any patents, copyrights or other intellectual property rights of Renesas Electronics or others.
3. You should not alter, modify, copy, or otherwise misappropriate any Renesas Electronics product, whether in whole or in part.
4. Descriptions of circuits, software and other related information in this document are provided only to illustrate the operation of semiconductor products and application examples. You are fully responsible for the incorporation of these circuits, software, and information in the design of your equipment. Renesas Electronics assumes no responsibility for any losses incurred by you or third parties arising from the use of these circuits, software, or information.
5. When exporting the products or technology described in this document, you should comply with the applicable export control laws and regulations and follow the procedures required by such laws and regulations. You should not use Renesas Electronics products or the technology described in this document for any purpose relating to military applications or use by the military, including but not limited to the development of weapons of mass destruction. Renesas Electronics products and technology may not be used for or incorporated into any products or systems whose manufacture, use, or sale is prohibited under any applicable domestic or foreign laws or regulations.
6. Renesas Electronics has used reasonable care in preparing the information included in this document, but Renesas Electronics does not warrant that such information is error free. Renesas Electronics assumes no liability whatsoever for any damages incurred by you resulting from errors in or omissions from the information included herein.
7. Renesas Electronics products are classified according to the following three quality grades: "Standard", "High Quality", and "Specific". The recommended applications for each Renesas Electronics product depends on the product's quality grade, as indicated below. You must check the quality grade of each Renesas Electronics product before using it in a particular application. You may not use any Renesas Electronics product for any application categorized as "Specific" without the prior written consent of Renesas Electronics. Further, you may not use any Renesas Electronics product for any application for which it is not intended without the prior written consent of Renesas Electronics. Renesas Electronics shall not be in any way liable for any damages or losses incurred by you or third parties arising from the use of any Renesas Electronics product for an application categorized as "Specific" or for which the product is not intended where you have failed to obtain the prior written consent of Renesas Electronics. The quality grade of each Renesas Electronics product is "Standard" unless otherwise expressly specified in a Renesas Electronics data sheets or data books, etc.

"Standard": Computers; office equipment; communications equipment; test and measurement equipment; audio and visual equipment; home electronic appliances; machine tools; personal electronic equipment; and industrial robots.

"High Quality": Transportation equipment (automobiles, trains, ships, etc.); traffic control systems; anti-disaster systems; anti-crime systems; safety equipment; and medical equipment not specifically designed for life support.

"Specific": Aircraft; aerospace equipment; submersible repeaters; nuclear reactor control systems; medical equipment or systems for life support (e.g. artificial life support devices or systems), surgical implantations, or healthcare intervention (e.g. excision, etc.), and any other applications or purposes that pose a direct threat to human life.

8. You should use the Renesas Electronics products described in this document within the range specified by Renesas Electronics, especially with respect to the maximum rating, operating supply voltage range, movement power voltage range, heat radiation characteristics, installation and other product characteristics. Renesas Electronics shall have no liability for malfunctions or damages arising out of the use of Renesas Electronics products beyond such specified ranges.
9. Although Renesas Electronics endeavors to improve the quality and reliability of its products, semiconductor products have specific characteristics such as the occurrence of failure at a certain rate and malfunctions under certain use conditions. Further, Renesas Electronics products are not subject to radiation resistance design. Please be sure to implement safety measures to guard them against the possibility of physical injury, and injury or damage caused by fire in the event of the failure of a Renesas Electronics product, such as safety design for hardware and software including but not limited to redundancy, fire control and malfunction prevention, appropriate treatment for aging degradation or any other appropriate measures. Because the evaluation of microcomputer software alone is very difficult, please evaluate the safety of the final products or system manufactured by you.
10. Please contact a Renesas Electronics sales office for details as to environmental matters such as the environmental compatibility of each Renesas Electronics product. Please use Renesas Electronics products in compliance with all applicable laws and regulations that regulate the inclusion or use of controlled substances, including without limitation, the EU RoHS Directive. Renesas Electronics assumes no liability for damages or losses occurring as a result of your noncompliance with applicable laws and regulations.
11. This document may not be reproduced or duplicated, in any form, in whole or in part, without prior written consent of Renesas Electronics.
12. Please contact a Renesas Electronics sales office if you have any questions regarding the information contained in this document or Renesas Electronics products, or if you have any other inquiries.

(Note 1) "Renesas Electronics" as used in this document means Renesas Electronics Corporation and also includes its majority-owned subsidiaries.

(Note 2) "Renesas Electronics product(s)" means any product developed or manufactured by or for Renesas Electronics.

E8/E8a Emulator

Additional Document for User's Manual
Notes on Connecting the H8/3664F, H8/3687F, H8/3694F,
H8/36037F, H8/36057F, H8/36049F, H8/36064F, H8/36087F,
H8/36077F, H8/36094F, H8/36109F, and H8/36079F

Renesas Microcomputer Development
Environment System
H8 Family / H8/300H Tiny Series

R0E000080KCE00EP5

Notes regarding these materials

1. This document is provided for reference purposes only so that Renesas customers may select the appropriate Renesas products for their use. Renesas neither makes warranties or representations with respect to the accuracy or completeness of the information contained in this document nor grants any license to any intellectual property rights or any other rights of Renesas or any third party with respect to the information in this document.
2. Renesas shall have no liability for damages or infringement of any intellectual property or other rights arising out of the use of any information in this document, including, but not limited to, product data, diagrams, charts, programs, algorithms, and application circuit examples.
3. You should not use the products or the technology described in this document for the purpose of military applications such as the development of weapons of mass destruction or for the purpose of any other military use. When exporting the products or technology described herein, you should follow the applicable export control laws and regulations, and procedures required by such laws and regulations.
4. All information included in this document such as product data, diagrams, charts, programs, algorithms, and application circuit examples, is current as of the date this document is issued. Such information, however, is subject to change without any prior notice. Before purchasing or using any Renesas products listed in this document, please confirm the latest product information with a Renesas sales office. Also, please pay regular and careful attention to additional and different information to be disclosed by Renesas such as that disclosed through our website. (<http://www.renesas.com>)
5. Renesas has used reasonable care in compiling the information included in this document, but Renesas assumes no liability whatsoever for any damages incurred as a result of errors or omissions in the information included in this document.
6. When using or otherwise relying on the information in this document, you should evaluate the information in light of the total system before deciding about the applicability of such information to the intended application. Renesas makes no representations, warranties or guaranties regarding the suitability of its products for any particular application and specifically disclaims any liability arising out of the application and use of the information in this document or Renesas products.
7. With the exception of products specified by Renesas as suitable for automobile applications, Renesas products are not designed, manufactured or tested for applications or otherwise in systems the failure or malfunction of which may cause a direct threat to human life or create a risk of human injury or which require especially high quality and reliability such as safety systems, or equipment or systems for transportation and traffic, healthcare, combustion control, aerospace and aeronautics, nuclear power, or undersea communication transmission. If you are considering the use of our products for such purposes, please contact a Renesas sales office beforehand. Renesas shall have no liability for damages arising out of the uses set forth above.
8. Notwithstanding the preceding paragraph, you should not use Renesas products for the purposes listed below:
 - (1) artificial life support devices or systems
 - (2) surgical implantations
 - (3) healthcare intervention (e.g., excision, administration of medication, etc.)
 - (4) any other purposes that pose a direct threat to human lifeRenesas shall have no liability for damages arising out of the uses set forth in the above and purchasers who elect to use Renesas products in any of the foregoing applications shall indemnify and hold harmless Renesas Technology Corp., its affiliated companies and their officers, directors, and employees against any and all damages arising out of such applications.
9. You should use the products described herein within the range specified by Renesas, especially with respect to the maximum rating, operating supply voltage range, movement power voltage range, heat radiation characteristics, installation and other product characteristics. Renesas shall have no liability for malfunctions or damages arising out of the use of Renesas products beyond such specified ranges.
10. Although Renesas endeavors to improve the quality and reliability of its products, IC products have specific characteristics such as the occurrence of failure at a certain rate and malfunctions under certain use conditions. Please be sure to implement safety measures to guard against the possibility of physical injury, and injury or damage caused by fire in the event of the failure of a Renesas product, such as safety design for hardware and software including but not limited to redundancy, fire control and malfunction prevention, appropriate treatment for aging degradation or any other applicable measures. Among others, since the evaluation of microcomputer software alone is very difficult, please evaluate the safety of the final products or system manufactured by you.
11. In case Renesas products listed in this document are detached from the products to which the Renesas products are attached or affixed, the risk of accident such as swallowing by infants and small children is very high. You should implement safety measures so that Renesas products may not be easily detached from your products. Renesas shall have no liability for damages arising out of such detachment.
12. This document may not be reproduced or duplicated, in any form, in whole or in part, without prior written approval from Renesas.
13. Please contact a Renesas sales office if you have any questions regarding the information contained in this document, Renesas semiconductor products, or if you have any other inquiries.

Contents

Section 1	Inside the E8/E8a Emulator User's Manual.....	1
Section 2	Connecting the Emulator with the User System.....	3
Section 3	Pin Assignments of the E8/E8a Connector.....	5
Section 4	Example of Emulator Connection.....	7
Section 5	Differences between the MCUs (H8/3664F, H8/3687(G)F, H8/3694(G)F, H8/36037(G)F, H8/36057(G)F, H8/36049(G)F, H8/36064(G)F, H8/36087(G)F, H8/36077(G)F, H8/36094(G)F, H8/36109(G)F, and H8/36079(G)F) and the Emulator	15

Note: This manual applies to the following product versions of the E8 or E8a emulator software.

Table E8/E8a Emulator Software

E8a Emulator V.1.00 Release 00 or later (H8 Tiny/Super Low Power E8a Emulator V.1.00.00 or later)*
E8 Emulator V.2.10 Release 00 or later (H8 Tiny/Super Low Power E8 Emulator V.1.05.00 or later)*

Note: This is a revision of the debugger.

Section 1 Inside the E8/E8a Emulator User's Manual

The E8 or E8a emulator (hereafter referred to as E8/E8a in this document) manual consists of two documents: the E8/E8a User's Manual and the E8/E8a Additional Document for User's Manual (this document). Be sure to read BOTH documents before using the E8/E8a emulator.

(1) E8/E8a Emulator User's Manual

The E8/E8a Emulator User's Manual describes the hardware specifications and how to use the emulator debugger.

- E8/E8a emulator hardware specifications
- Connecting the E8/E8a emulator to the host computer or user system
- Operating the E8/E8a emulator debugger
- Tutorial: From starting up the E8/E8a emulator debugger to debugging

(2) E8/E8a Additional Document for User's Manual

The E8/E8a Additional Document for User's Manual describes content dependent on the MCUs and precautionary notes.

- Example of the E8/E8a emulator connection or interface circuit necessary for designing the hardware
- Notes on using the E8/E8a emulator
- Setting the E8/E8a emulator debugger during startup

Section 2 Connecting the Emulator with the User System

Before connecting an E8/E8a emulator (hereafter referred to as emulator) with the user system, a connector must be installed in the user system so that a user system interface cable can be connected. When designing the user system, refer to the connector and recommended circuits shown in this manual.

Before designing the user system, be sure to read the E8/E8a emulator user's manual and the hardware manual for related MCUs.

Table 2.1 shows the recommended connector for the emulator.

Table 2.1 Recommended Connector

Type Number	Manufacturer	Specifications
2514-6002	3M Limited	14-pin straight type

Connect pins 2, 4, 6, 10, 12, and 14 of the user system connector to GND firmly on the PCB. These pins are used as electrical GND and to monitor the connection of the user system connector. Note the pin assignments of the user system connector.

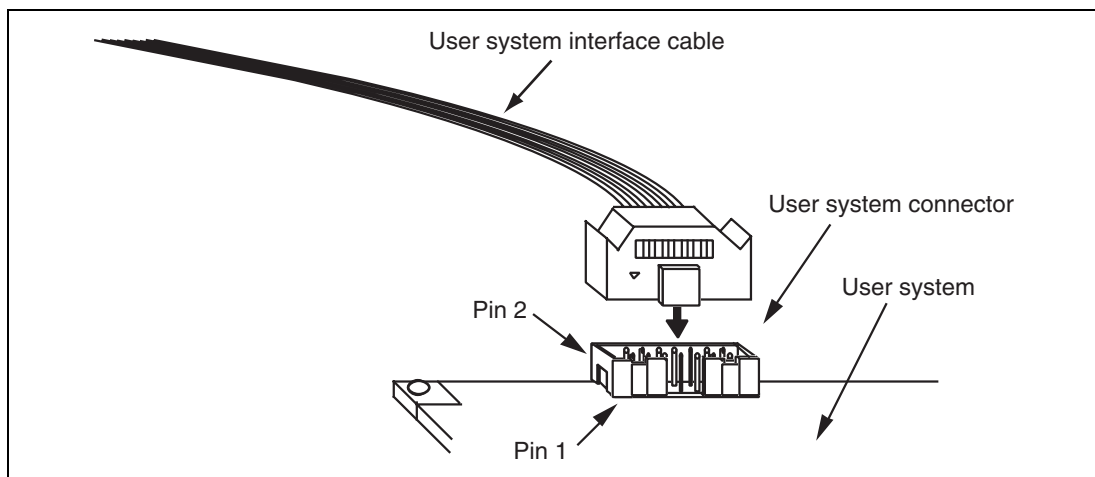

Figure 2.1 Connecting the User System Interface Cable to the User System

- Notes:
1. The pin number assignments of the 14-pin connector differ from those of the E10A-USB emulator; however, the physical location is the same.
 2. Do not place any components within 3 mm of the connector.
 3. When the emulator is used in the [Program Flash] mode, connect the emulator similarly to the user system.

Section 3 Pin Assignments of the E8/E8a Connector

Figure 3.1 shows the pin assignments of the connector.

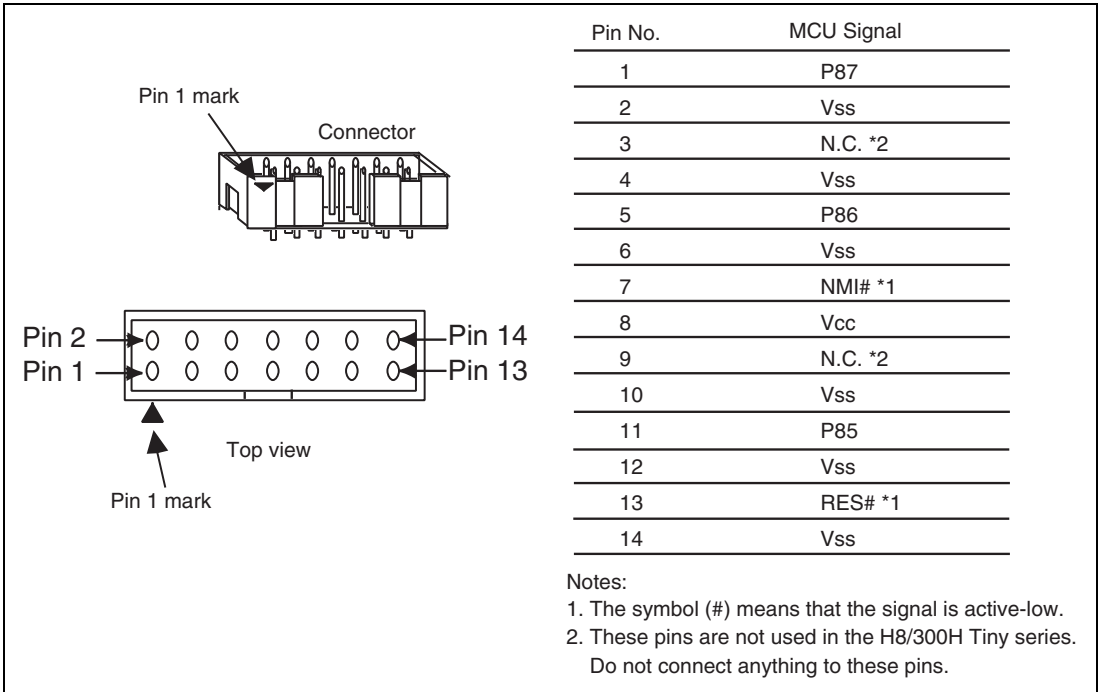

Figure 3.1 Pin Assignments of the Connector

Section 4 Example of Emulator Connection

Figures 4.1 and 4.2 show examples of emulator connection to the MCU without the POR and LVD options (H8/3664F, H8/3687F, H8/3694F, H8/36037F, H8/36057F, H8/36049F, H8/36094F, and H8/36109F; hereafter referred to as the MCU without the POR and LVD options) and to the MCU with the POR and LVD options installed (H8/3687(G)F, H8/3694(G)F, H8/36037(G)F, H8/36057(G)F, H8/36049(G)F, H8/36064(G)F, H8/36087(G)F, H8/36077(G)F, H8/36094(G)F, H8/36109(G)F, and H8/36079(G)F; hereafter referred to as the MCU with the POR and LVD options), respectively.

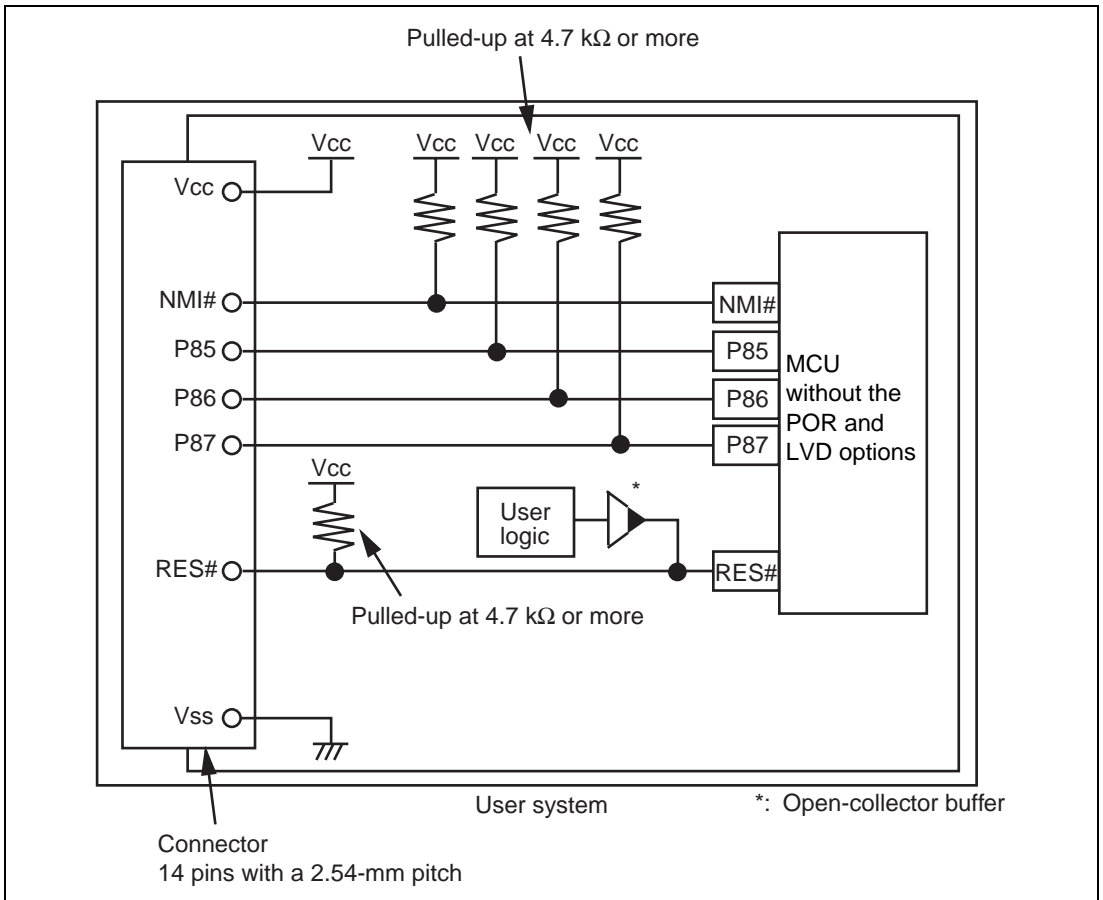

Figure 4.1 Example of Emulator Connection (MCU without POR and LVD Options)

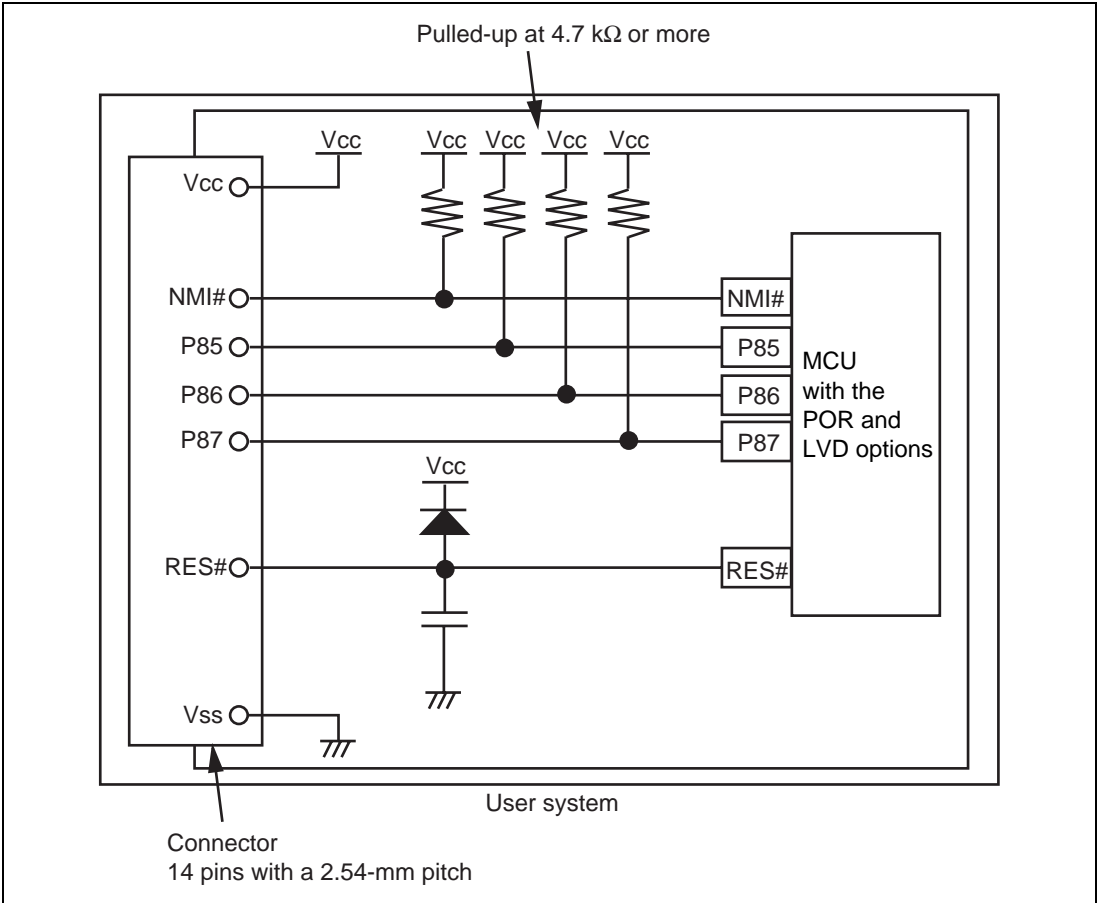

Figure 4.2 Example of Emulator Connection (MCU with POR and LVD Options)

Notes: 1. P85 to P87 pins are used by the emulator. Pull up and connect the emulator and MCU pins.

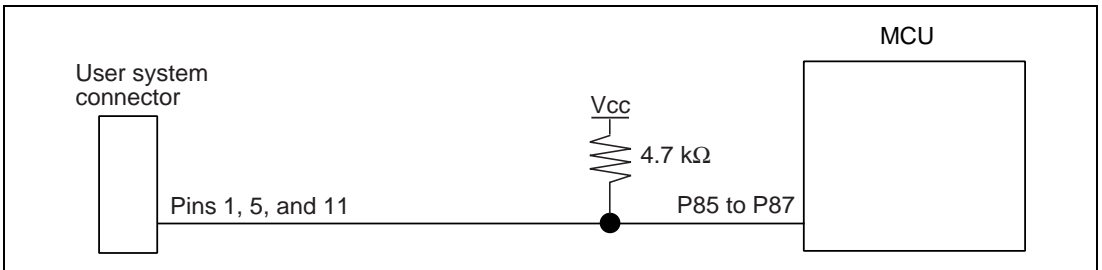

Figure 4.3 Connection of Emulator and P85 to P87 Pins

2. The NMI# signal is used for forced break control by the emulator. Connect the emulator and MCU pins directly. In debugging without forced break control, change the mode with the High-performance Embedded Workshop. Then, when the user logic is connected with the open-collector output buffer, the NMI# pin can be used in the user system (however, at power-on, the NMI# pin is used by the emulator).

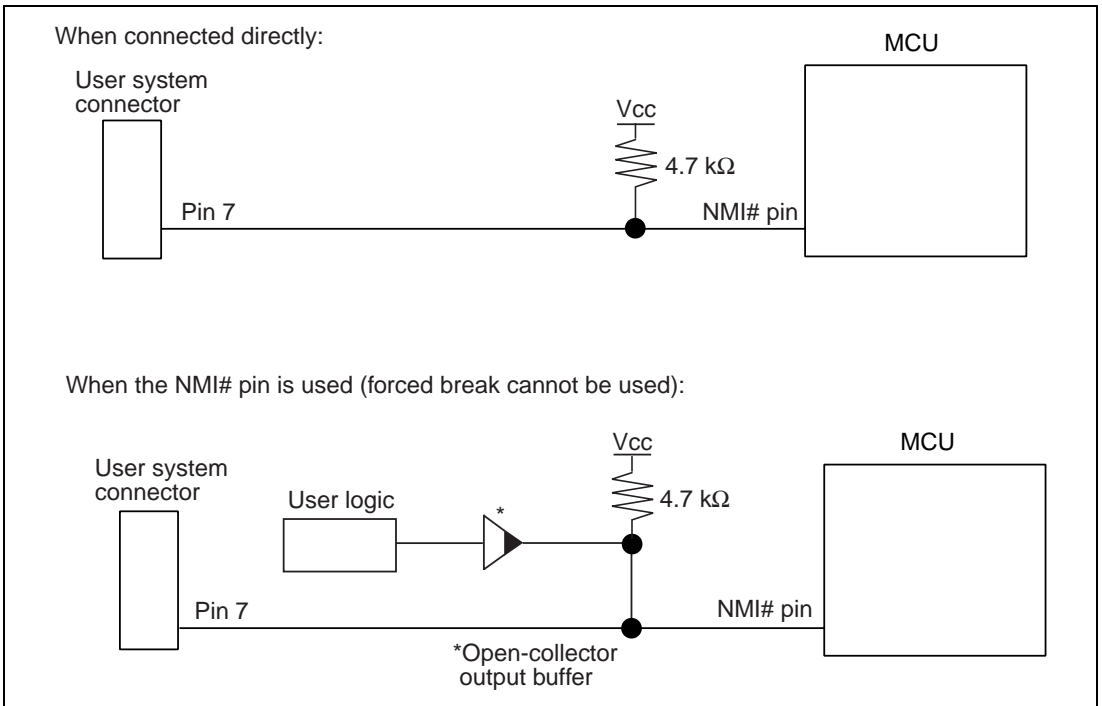

Figure 4.4 Connection of Emulator and NMI# Pin

- The RES# pin is used by the emulator. Create the following circuit by connecting the open-collector output buffer so that reset input can be accepted from the emulator.

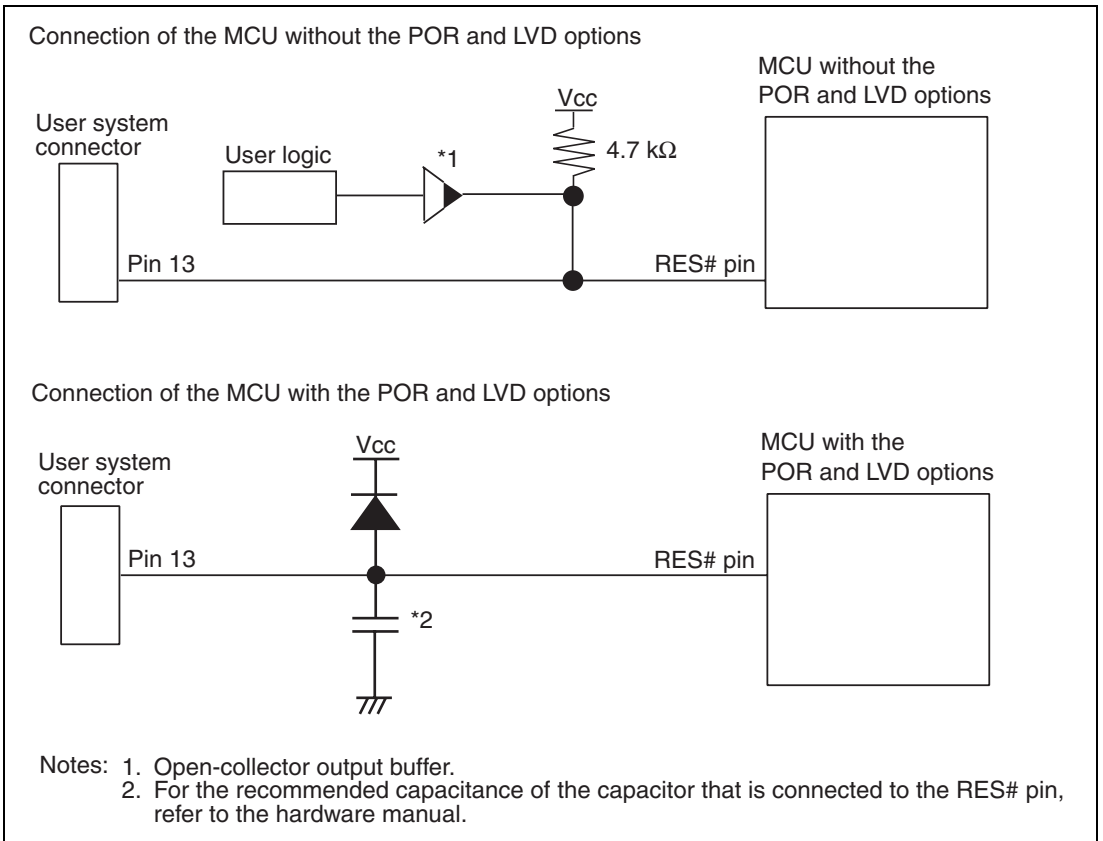

Figure 4.5 Example of a Reset Circuit

- Connect Vss and Vcc with the Vss and Vcc of the MCU, respectively (within the guaranteed range of the microcomputer).
When the power-supply mode is used, the power is supplied to the user system. Check that the power consumption or voltage of the user system is within the available range of E8/E8a and avoid a problem such as closing of the power-supply circuit.
- Connect nothing with N.C.

WARNING

In the power-supply mode, connect the emulator after checking that the power-supply circuit on the user system is not closed or the pin number assignments of the user system connector is correct.

Failure to do so will result in a FIRE HAZARD and will damage the host computer, the emulator, and the user system.

6. Figures 4.6 and 4.7 show the interface circuit in the E8 and E8a emulators, respectively. Use these figures as references when determining the pull-up resistance value.

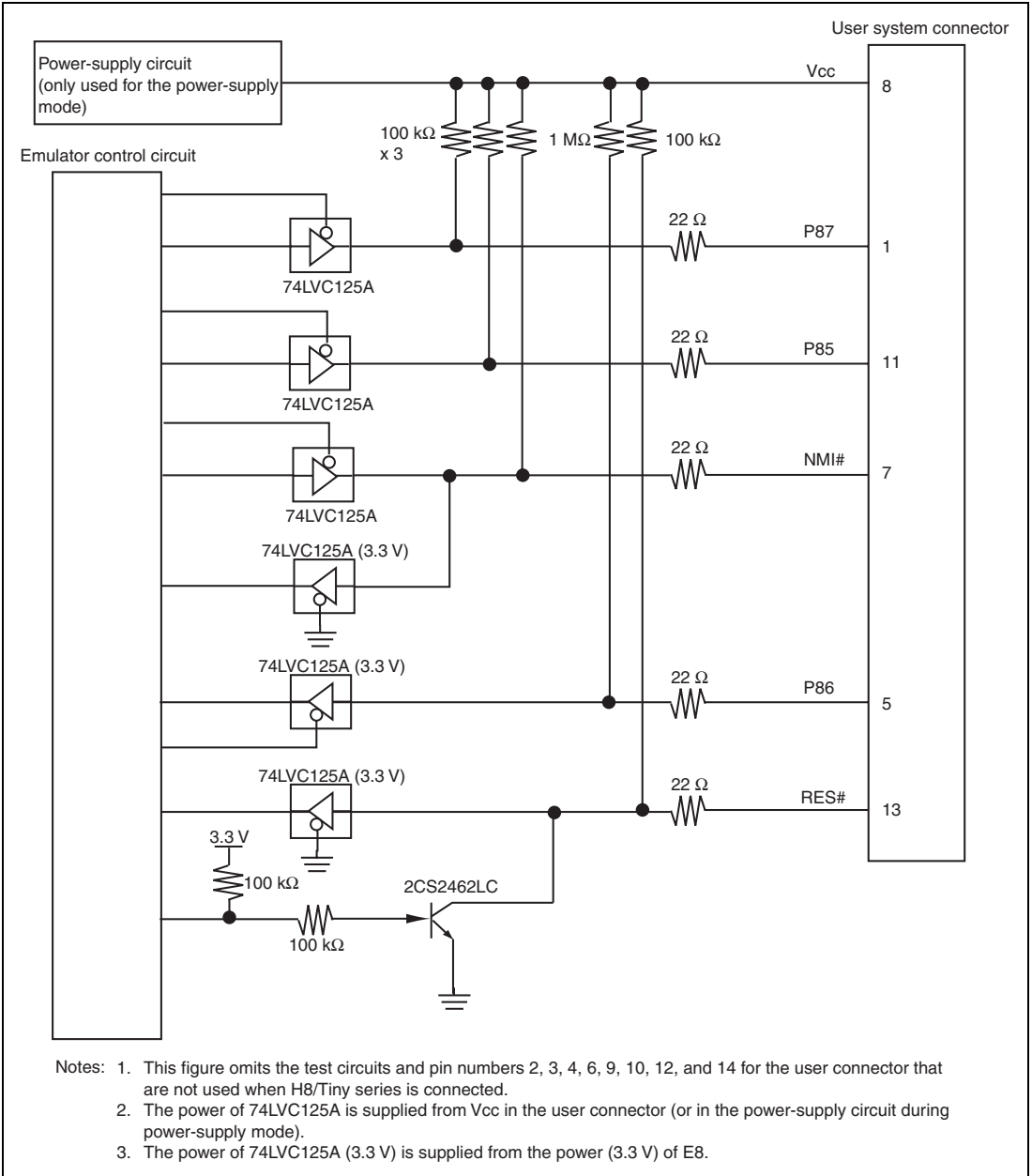

Figure 4.6 Interface Circuit in the E8 Emulator (Reference)

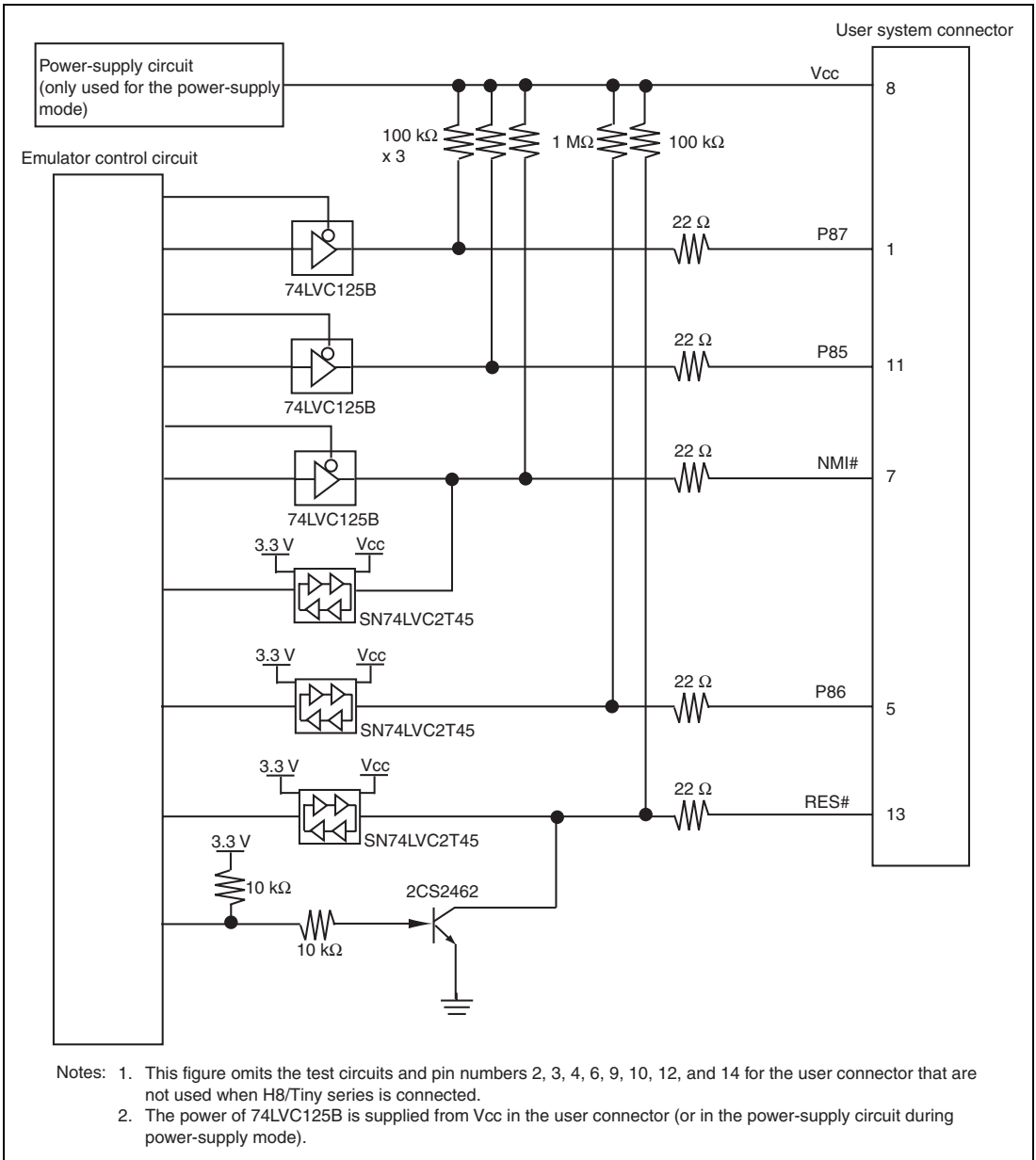

Figure 4.7 Interface Circuit in the E8a Emulator (Reference)

Section 5 Differences between the MCUs (H8/3664F, H8/3687(G)F, H8/3694(G)F, H8/36037(G)F, H8/36057(G)F, H8/36049(G)F, H8/36064(G)F, H8/36087(G)F, H8/36077(G)F, H8/36094(G)F, H8/36109(G)F, and H8/36079(G)F) and the Emulator

This section describes the differences between the emulator and MCU operations.

1. [Emulator Setting] Dialog Box

The [Emulator Setting] dialog box is provided for setting the items that need to be set when the emulator starts up (settings are saved in the session).

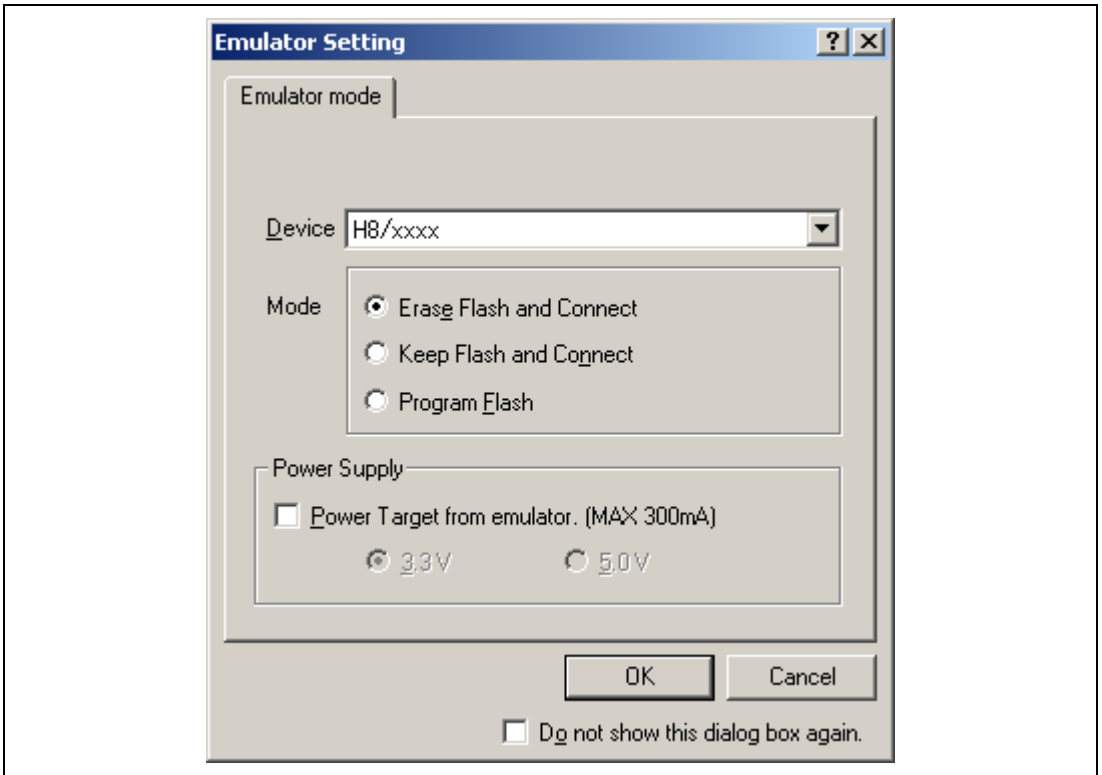

Figure 5.1 [Emulator Setting] Dialog Box

To keep the [Emulator Setting] dialog box closed next time the emulator is started, check "Do not show this dialog box again." at the bottom of the [Emulator Setting] dialog box. You can open the [Emulator Setting] dialog box using either one of the following methods:

- After the emulator gets started, select Menu - [Setup] -> [Emulator] -> [Emulator Setting...].
- Start the emulator while holding down the Ctrl key.
- After the emulator gets started and an error occurred, restart the emulator.

When you check "Do not show this dialog box again.", the emulator doesn't supply power to the user system. To use this check box, start the emulator after turning on the power.

2. Emulator Mode

The selection of the device, the specification of the mode, and the setting of the power supply are done in the [Emulator mode] page of the [Emulator Setting] dialog box.

— Device

Select the device name in use from the [Device] combo box. The following items are selected in the [Mode] group box.

— Modes

- Erase Flash and Connect

This mode is used when there is no emulator program in the flash memory of the target device. In this mode, data of the flash memory of the target device is erased when the emulator is activated. Select this item when the emulator is firstly activated, the version of the emulator's software is updated, or the ID code is changed.

- Keep Flash and Connect

This mode is used when there is an emulator program in the flash memory of the target device. Enter the ID code specified above ('Erase Flash and Connect'). If an incorrect code is entered, all the programs on the flash memory will be erased.

Note: When the emulator gets started in this mode after selecting "Do not show this dialog box again.", the initial values of the ID code are '00E8' and '0E8a', respectively, for the E8 and E8a emulators. If you use the ID code other than the initial value, do not use "Do not show this dialog box again."

- Program Flash

This mode is used when the emulator is used for programming the flash memory. Debugging the program is disabled. To download the load module, register it in the workspace.

Note: In the H8/Tiny or H8/Super Low Power device, the ID code is not entered in the Program Flash mode.

- Power Supply

When [Power Target from emulator. (MAX 300mA)] is checked, power will be supplied to the user system up to 300 mA. Then select 3.3 V or 5.0 V according to the power voltage of the user system.

3. Emulator Activation and ID Code

In the H8/Tiny- or H8/Super Low Power-series MCU, the [System Clock] and [ID Code] dialog boxes are set when the emulator is activated.

- Setting the system clock

Enter the clock value input to the board in use. The initial value differs in each MCU.

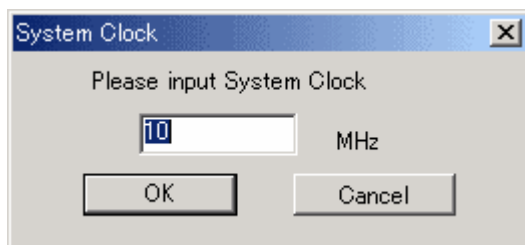

Figure 5.2 [System Clock] Dialog Box

- Setting the ID code

When the emulator is activated in the [Erase Flash and Connect] mode, enter any hexadecimal four-digit ID code to be set (except for H'FFFF). The initial value is H'00E8.* When the emulator is activated in the [Keep Flash and Connect] mode, enter the correct ID code. If an incorrect ID code is entered, all the contents of the flash memory will be erased. In this case, restart the emulator in the [Erase Flash and Connect] mode.

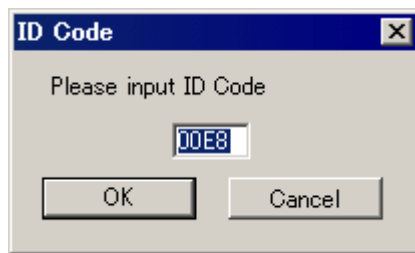

Figure 5.3 [ID Code] Dialog Box

Note: For the E8a emulator, the initial value is H'0E8a.

4. When the emulator system is initiated, it initializes the general registers and part of the control registers as shown in table 5.1.

Table 5.1 Register Initial Values at Emulator Power-On

Register	Initial Value
PC	Reset vector value in the vector address table
ER0 to ER6	H'0000
ER7 (SP)	H'FF80 (H'FFFF80 for H8/36049F, H8/36109F, and H8/36079F)
CCR	H'80

5. Low-Power Mode

During a user program break, the CPU operating frequency is forced to a system clock (ϕ) for high-speed operation.

6. RES# Signal

The MCU signals are only valid during user program execution started with clicking the GO or STEP-type button. During a user program break, the RES# signal is not sent to the MCUs.

Note: Do not start user program execution or access the memory while control input signal (RES#) is being low. A TIMEOUT error will occur.

7. System Control Register

In the emulator, the internal I/O registers can be accessed from the [IO] window. However, be careful when accessing the system control register. The emulator saves the register value of the system control register at a break and returns the value when the user program is executed. Since this is done during a break, do not rewrite the system control register in the [IO] window.

8. Memory Access during Emulation

If the memory contents are referenced or modified during emulation, realtime emulation cannot be performed because the user program is temporarily halted.

9. The emulator communicates with the MCUs by using the NMI#, RES#, and P85 to P87 pins. These pins cannot be used, however, the NMI# pin can be used by changing the setting of the [NMI signal] group box in the [Configuration] dialog box.

10. Sum Data Displayed in the Program Flash Mode

Sum data, which is displayed in the 'Program Flash' mode, is a value that data in the whole ROM areas has been added by byte (including data in the dedicated ROM area for the emulator).

11. Note on Executing the User Program

The set value is rewritten since the emulator uses flash memory and watchdog timer registers during programming (Go, Step In, Step Out, or Step Over) of the flash memory.

12. The power consumed by the MCU can reach several milliamperes. This is because the user power supply drives ICs to make the communication signal level match the user-system power-supply voltage. The power consumed rises little during user program execution since the emulator does not perform communication; it rises more during a break.

13. Program Area for the Emulator

Do not access a part of areas in the flash memory or the internal RAM since the emulator program uses these areas. If the contents of the program area for the emulator are changed, the emulator will not operate normally. In this case, restart the emulator with the Erase Flash and Connect mode.

Table 5.2 Program Area for the E8/E8a Emulator

MCU Name	Program Area
H8/3664F	Flash memory: H'7000 to H'7FFF
H8/3694(G)F	Internal RAM: H'F780 to H'FB7F
H8/36064(G)F H8/36094(G)F	Vector, etc.: H'0002 to H'0007, H'000E to H'000F, H'0018 to H'0019
H8/3687(G)F	Flash memory: H'D000 to H'DFFF
H8/36037(G)F	Internal RAM: H'F780 to H'FB7F
H8/36057(G)F H8/36087(G)F H8/36077(G)F	Vector, etc.: H'0002 to H'0007, H'000E to H'000F, H'0018 to H'0019
H8/36049(G)F	Flash memory: H'018000 to H'018FFF (H8/36049(G)F)
H8/36109(G)F	H'01F000 to H'01FFFF (H8/36109(G)F and H8/36079(G)F)
H8/36079(G)F	Internal RAM: H'FFF780 to H'FFFB7F
	Vector, etc.: H'000004 to H'00000D, H'00001C to H'00001F, H'000030 to H'000033

14. The emulator uses a two-word stack pointer for values stored on a user program break. Therefore, the stack area must accept two-word addresses.

15. Do not use an MCU that has been used for debugging.

If the flash memory is rewritten many times, data may be lost due to retention problems after the emulator has been left for a few days and the data will be erased. If an error message is displayed, exchange the MCU for a new one.

16. Forced Break Function

When the NMI# signal is used for a forced break in the emulator, the vector address of NMI# is rewritten by the emulator program. An error will occur if a file in the host computer and the flash memory contents are verified. Do not use the flash memory contents as the ROM data for the mask ROM after it has been saved.

17. Setting the Usage of the NMI# Signal

In the [Configuration] dialog box, when the NMI# signal is changed as it is used in the user program, the vector address of NMI# is not recovered. Reload the user program.

18. Address Break Release Function

When the address break function is not released for users, the vector address of address break is rewritten by the emulator program. An error will occur if a file in the host computer and the flash memory contents are verified. Do not use the flash memory contents as the ROM data for the mask ROM after it has been saved.

19. Initializing the Internal I/O Register with the Reset_CPU Function

Be sure to initialize the internal I/O registers shown below by the user program since they are not initialized by selecting [Debug] – [Reset CPU] or using the RESET command.

Table 5.3 Registers Not Initialized

MCU Name	Register Not Initialized
H8/3664F	IEGR1, IEGR2, IENR1, IRR1, IWPR, MSTCR1, TSCR
H8/3687F	IEGR1, IEGR2, IENR1, IENR2, IRR1, IRR2, IWPR, MSTCR1, MSTCR2
H8/3694F	IEGR1, IEGR2, IENR1, IRR1, IWPR, MSTCR1
H8/36037F H8/36057F	IEGR1, IEGR2, IENR1, IENR2, IRR1, IRR2, IWPR, MSTCR1, MSTCR2
H8/36049F	IEGR1, IEGR2, IENR1, IENR2, IRR1, IRR2, IWPR, MSTCR1, MSTCR2
H8/36064F	IEGR1, IEGR2, IENR1, IENR2, IRR1, IRR2, IWPR, MSTCR1, MSTCR2
H8/36087F	IEGR1, IEGR2, IENR1, IENR2, IRR1, IRR2, IWPR, MSTCR1, MSTCR2
H8/36109F	IEGR1, IEGR2, IENR1, IENR2, IRR1, IRR2, IWPR, MSTCR1, MSTCR2
H8/36077F H8/36079F	IEGR1, IEGR2, IENR1, IENR2, IRR1, IRR2, IWPR, MSTCR1, MSTCR2
H8/36094F	IEGR1, IEGR2, IENR1, IRR1, IWPR, MSTCR1

20. Step Execution of the SLEEP Instruction

When the interrupt mask bit (I) in the condition code register (CCR) is 1, do not perform step execution of the SLEEP instruction. If the step execution is performed and not finished correctly, restart the emulator.

21. Processing at Emulator Activation (H8/36064(G)F, H8/36077(G)F, H8/36094(G)F, and H8/36109(G)F)

When the emulator is activated, the watchdog timer is not active; the operation of the emulator differs from that of the MCU.

22. Items Set in the [Configuration] Dialog Box

The emulator operation conditions are set in the [Configuration] dialog box.

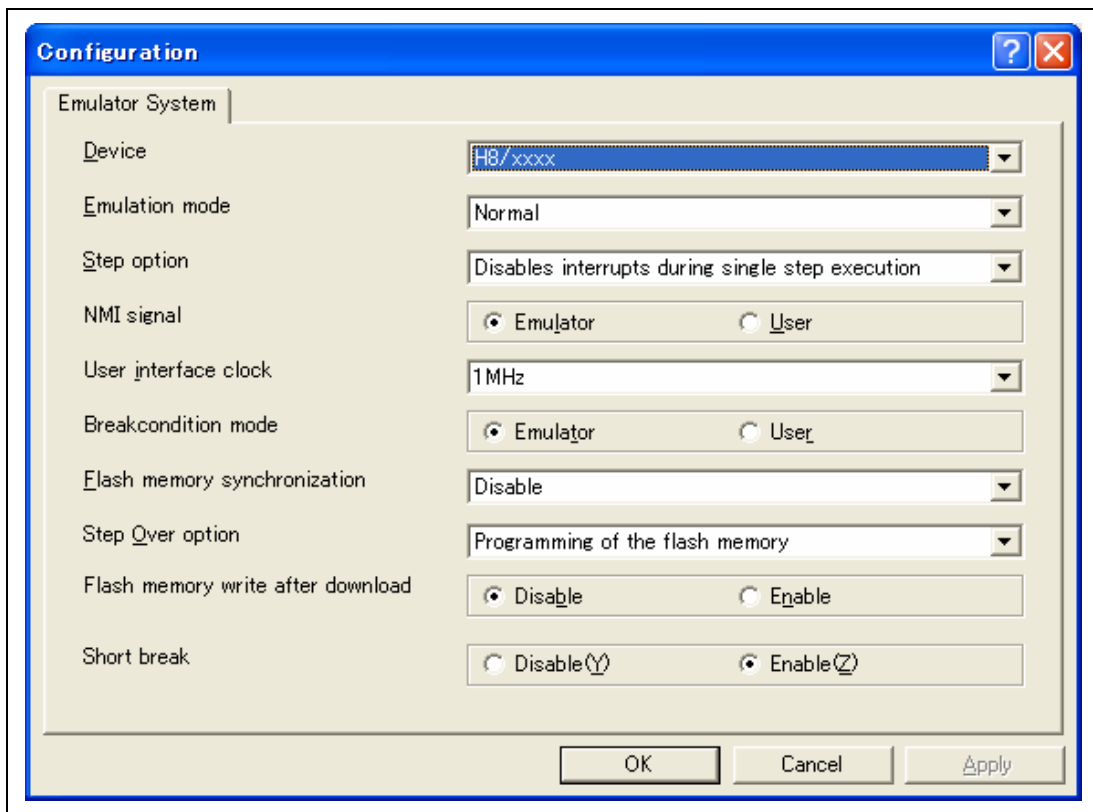

Figure 5.4 [Configuration] Dialog Box ([Emulator System] Page)

Items that can be displayed in this dialog box are listed below.

[Device] combo box	Displays the MCU name.
[Emulation mode] combo box	Selects the emulation mode at user program execution. Select Normal to perform normal emulation. Select No break to disable PC breakpoint or break condition settings during emulation.
[Step option] combo box	Sets the step interrupt option. Disable interrupts during single step execution: Disables interrupts ^{*1} during step execution. Enable interrupts during single step execution: Enables interrupts ^{*1} during step execution.
[NMI signal] group box	Sets the use of the NMI# signal. When used as a forced break in the emulator, select Emulator. In this case, the NMI# signal cannot be used. The contents of the NMI# vector address are rewritten by the emulator program. When used in the user program, select User. In this case, the forced break cannot be used. Before user program execution, set the breakpoints or break conditions for the exception processing and generate exceptions to halt the program.
[User interface clock] combo box	Displays the transfer clock of the user interface.
[Breakcondition mode] group box	Sets the address break release function. When the address break function is not used in the user program, select Emulator. In this case, the hardware break and step functions can be used. The contents of the vector address are rewritten by the emulator program to satisfy the break conditions. When the address break is used in the user program, select User. In this case, the hardware break and step functions cannot be used.
[Flash memory synchronization] combo box	Selects whether or not the contents of the flash memory are acquired by the emulator when the user program is stopped or the position where the PC break is set is put back as the original code. When the flash memory is not programmed by the user program, its contents need not be acquired by the emulator.

If there is no problem with the state that the program in the flash memory has been replaced as the PC break code, the position where the PC break is set needs not be put back as the original code.

Disable: Read or program is not performed for the flash memory except when the emulator is activated, the flash memory area is modified, and the settings of the PC break to the flash memory area are changed.

PC to flash memory: When the user program is stopped, the specified PC break code is replaced as the original instruction. Select this option if there is a problem with the state that the program in the flash memory has been replaced as the PC break code.

Flash memory to PC: When the user program is stopped, the contents of the flash memory are read by the emulator. Select this option if the flash memory is reprogrammed by the user program.

PC to flash memory, Flash memory to PC:
When the user program is stopped, the contents of the flash memory are read by the emulator and the specified PC break code is replaced as the original instruction. Select this option if the flash memory is reprogrammed by the user program and there is a problem with the state that the program in the flash memory has been replaced as the PC break code.

[Step Over option] combo box

Enables or disables programming of the flash memory while executing step operation.

Programming of the flash memory: Uses a software break for step operation (e.g. Step Over) and enables programming of the flash memory.

No Programming of the flash memory: Uses Break Condition for step operation (e.g. Step Over) and disables programming of the flash memory^{*2}.

[Flash memory write after download] group box

Enables or disables programming of the flash memory after downloading the program.

Disable: Disables programming of the flash memory after downloading the program.

Enable: Enables programming of the flash memory after downloading the program.

E8/E8a Emulator

Additional Document for User's Manual

Notes on Connecting the H8/3664F, H8/3687F, H8/3694F, H8/36037F, H8/36057F, H8/36049F, H8/36064F, H8/36087F, H8/36077F, H8/36094F, H8/36109F, and H8/36079F

Publication Date: Rev.1.00, April 22, 2005
Rev.5.00, July 20, 2007

Published by: Sales Strategic Planning Div.
Renesas Technology Corp.

Edited by: Customer Support Department
Global Strategic Communication Div.
Renesas Solutions Corp.

Renesas Technology Corp. Sales Strategic Planning Div. Nippon Bldg., 2-6-2, Ohte-machi, Chiyoda-ku, Tokyo 100-0004, Japan



RENESAS SALES OFFICES

<http://www.renesas.com>

Refer to "<http://www.renesas.com/en/network>" for the latest and detailed information.

Renesas Technology America, Inc.

450 Holger Way, San Jose, CA 95134-1368, U.S.A
Tel: <1> (408) 382-7500, Fax: <1> (408) 382-7501

Renesas Technology Europe Limited

Dukes Meadow, Millboard Road, Bourne End, Buckinghamshire, SL8 5FH, U.K.
Tel: <44> (1628) 585-100, Fax: <44> (1628) 585-900

Renesas Technology (Shanghai) Co., Ltd.

Unit 204, 205, AZIACenter, No.1233 Lujiazui Ring Rd, Pudong District, Shanghai, China 200120
Tel: <86> (21) 5877-1818, Fax: <86> (21) 6887-7898

Renesas Technology Hong Kong Ltd.

7th Floor, North Tower, World Finance Centre, Harbour City, 1 Canton Road, Tsimshatsui, Kowloon, Hong Kong
Tel: <852> 2265-6688, Fax: <852> 2730-6071

Renesas Technology Taiwan Co., Ltd.

10th Floor, No.99, Fushing North Road, Taipei, Taiwan
Tel: <886> (2) 2715-2888, Fax: <886> (2) 2713-2999

Renesas Technology Singapore Pte. Ltd.

1 Harbour Front Avenue, #06-10, Keppel Bay Tower, Singapore 098632
Tel: <65> 6213-0200, Fax: <65> 6278-8001

Renesas Technology Korea Co., Ltd.

Kukje Center Bldg. 18th Fl., 191, 2-ka, Hangang-ro, Yongsan-ku, Seoul 140-702, Korea
Tel: <82> (2) 796-3115, Fax: <82> (2) 796-2145

Renesas Technology Malaysia Sdn. Bhd

Unit 906, Block B, Menara Amcorp, Amcorp Trade Centre, No.18, Jalan Persiaran Barat, 46050 Petaling Jaya, Selangor Darul Ehsan, Malaysia
Tel: <603> 7955-9390, Fax: <603> 7955-9510

**E8/E8a Emulator
Additional Document for User's Manual
Notes on Connecting the H8/3664F,
H8/3687F, H8/3694F, H8/36037F,
H8/36057F, H8/36049F, H8/36064F,
H8/36087F, H8/36077F, H8/36094F,
H8/36109F, and H8/36079F**



Renesas Electronics Corporation

1753, Shimonumabe, Nakahara-ku, Kawasaki-shi, Kanagawa 211-8668 Japan

REJ10B0191-0500