

ISL54225IRTZEVAL1Z

ISL54225IRTZEVAL1Z Evaluation Board

AN1576
Rev 0.00
March 16, 2012

Description

The ISL54225IRTZEVAL1Z evaluation board is designed to provide a quick and easy method for evaluating the ISL54225 USB Switch IC.

The ISL54225 device is a unique IC. To use this evaluation board properly requires a thorough knowledge of the operation of the IC. See the [ISL54225 datasheet](#) for an understanding of the functions and features of the device. Studying the device's truth-table along with its pin-out diagram on page 2 of the data sheet is the best way to get a quick understanding of how the part works.

The ISL54225IRTZEVAL1Z evaluation board is shown in Figure 1. The ISL54225 TDFN IC is soldered onto the center of the evaluation board and is designated as U1.

The evaluation board contains USB connectors, banana jacks, and toggle switches to allow the user to easily interface with the IC to evaluate its functions, features, and performance. For example, with the board properly powered and configured as shown in Figure 2, the user can control the logic pins with the toggle switches S1 (SEL) and S2 (\overline{OE}). These switches allow the user to switch between the two high-speed USB devices while connected to a single USB host (computer).

In a typical application, the ISL54225 dual SPDT device is used to select between two different USB transceiver sections of a media player. Logic control from a microprocessor determines which section to connect to the computer. The following sequence could be used to change channels:

1. A signal is sent to take the \overline{OE} pin High, which opens all switches. The off-isolation of the ISL54225 device allows the present active channel to properly disconnect from the computer.
2. The SEL pin is set to select the other USB channel.
3. The \overline{OE} pin is taken Low to close the switches, which makes the connection between the computer and the other USB section of the player.

This application note guides the user through configuring and using the ISL54225IRTZEVAL1Z evaluation board to evaluate the ISL54225 device.

Features

- Standard USB Connectors
- Banana Jacks for Power, Ground, V_{BUS} and Logic Connections
- Toggle Switches for Easy Control of Logic Pins
- Jumpers to Allow a USB Device to Get Its V_{BUS} Voltage from the Host Controller
- Convenient Test Points and Connections for Test Equipment

ISL54225IRTZEVAL1Z Evaluation Board

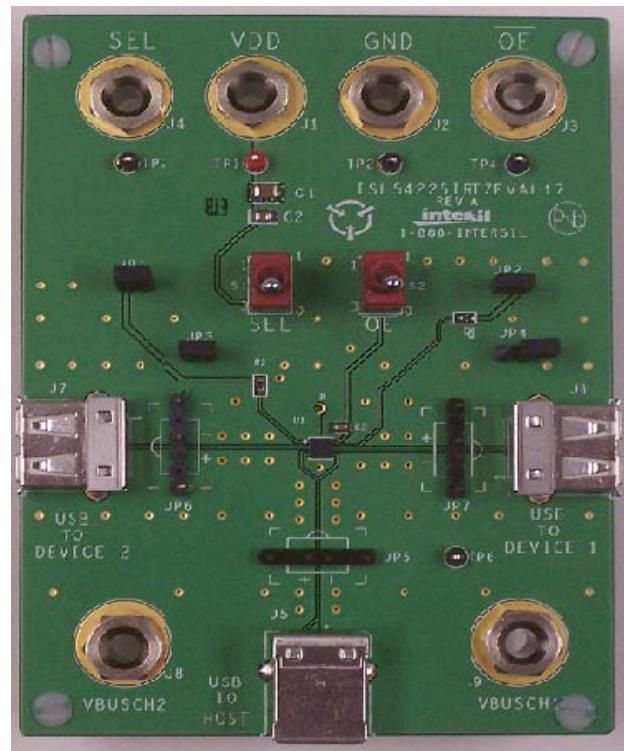

FIGURE 1. ISL54225IRTZEVAL1Z EVALUATION BOARD

Board Architecture/Layout

The basic layout of the evaluation board is as follows (see Figure 1 and “ISL54225IRTZEVAL1Z Board Schematic” on page 6).

- Power and Ground connections are at the banana jacks J1 and J2 at the top of the board.
- Logic connections, SEL and \overline{OE} , are at the top of the board at banana jacks J4 and J3. They can also be accessed by using the toggle switches S1 and S2, located in the upper center of the board. To use the toggle switches, jumpers JP1 and JP2 must be installed. To control the logic through the J4 and J3 banana jacks, the JP1 and JP2 jumpers must not be populated.
- The USB connector, J5 (USB TO HOST) located at the bottom of the board, provides a USB connection to an upstream host controller (Computer).
- USB connectors J6 (USB TO DEVICE 1) and J7 (USB TO DEVICE 2), located on the right and left sides of the board, provide USB connections to downstream USB devices.
- Banana jacks J8 (VBUSCH2) and J9 (VBUSCH1) provide V_{BUS} voltage for the USB devices. Optionally, V_{BUS} for a USB device can be connected to the host controller V_{BUS} through jumpers JP4 (Device 1) and JP3 (Device 2).
- The ISL54225 IC (U1) is located in the center of the board. The evaluation board has a Pin 1 indicator dot to show how the IC should be oriented on the evaluation board. The IC Pin 1 indicator dot should be aligned with the evaluation board Pin 1 indicator dot.

IC Power Supply

A DC power supply connected at banana jacks J1 (VDD) and J2 (GND) provides power to the ISL54225 IC. The IC requires a 2.7VDC to 5.25VDC power supply for proper operation. The power supply should be capable of delivering 100 μ A of current.

V_{BUS} Power Supply

A DC power supply connected at banana jacks J9 (VBUSCH1) and J8 (VBUSCH2) provides the V_{BUS} voltage required by the USB devices. The devices require a DC power supply in the range of 4.4V to 5.25V for proper operation. The power supply should be capable of delivering 100mA of current.

The J8 banana jack is connected to the VBUS pin of the J7 “A” type USB receptacle. The J9 banana jack is connected to the VBUS pin of the J6 “A” type receptacle.

V_{BUS} voltage can be provided from the USB host controller (computer) by installing a jumper at either JP3 or JP4.

With a jumper at JP4, the V_{BUS} voltage from J5 (USB TO HOST) USB connector gets routed to the J6 connector. With this jumper installed, no DC supply should be connected at the J9 (VBUSCH1) banana jack.

With a jumper at JP3, the V_{BUS} voltage from J5 (USB TO HOST) USB connector gets routed to the J7 connector. With this jumper installed, no DC supply should be connected at the J8 (VBUSCH2) banana jack.

Logic Control

The state of the ISL54225 device is determined by the voltage at the SEL pin and the \overline{OE} pin. Access to the SEL pin is through the banana jack J4 (SEL) or the toggle switch S1 (SEL). Access to the \overline{OE} pin is through the banana jack J3 (\overline{OE}) or the toggle switch S2 (\overline{OE}). To use the toggle switches to control the logic, jumpers should be installed at JP1 and JP2. Remove jumpers to control the logic through the banana jacks.

If SEL is driven Low (to ground), \overline{OE} = Low, and the signal voltage is in the range of 0V to 3.6V, the high-speed (HS) channel 1 switches will be ON. In this state, the USB host controller (computer) connected at J5 will be connected through to the USB device connected at J6 and data will be able to be transmitted between the computer and the device.

If SEL is driven High, \overline{OE} = Low, and the signal voltage is in the range of 0V to 3.6V, the high-speed (HS) channel 2 switches will be ON. In this state, the USB host controller (computer) connected at J5 will be connected through to the USB device connected at J7 and data will be able to be transmitted between the computer and the device.

If \overline{OE} = High, all switches are OFF. Neither device is connected through to the host controller.

In a typical application, the ISL54225 dual SPDT device is used to select between two different USB transceiver sections of a media player. Logic control from a microprocessor determines which section to connect to the computer. To change channels, the following sequence could be followed:

1. A signal from the microprocessor is sent to take the \overline{OE} pin High, which opens all switches. The off-isolation of the ISL54225 device allows the present active channel to properly disconnect from the computer.
2. The microprocessor drives the SEL pin to select the other USB channel.
3. The microprocessor drives the \overline{OE} pin Low, which closes the switches and makes the connection between the computer and the other USB section of the player.

USB Connections

A “B” type USB receptacle labeled “USB TO HOST” (J5) is located on the bottom of the board. This receptacle should be connected, using a standard USB cable, to the upstream USB host controller, which is usually a PC computer or hub. When this connection is made, the ISL54225 device will connect the computer through to the USB device determined by the voltage at the SEL logic control pin.

An “A” type USB receptacle labeled “USB TO DEVICE 1” (J6) is located on the right side of the board. A USB device can be plugged directly into this receptacle or through a standard USB cable.

An “A” type USB receptacle labeled “USB TO DEVICE 2” (J7) is located on the left side of the board. A USB device can be plugged directly into this receptacle or through a standard USB cable.

The USB switches are bi-directional, which allows the host (computer) and downstream USB device to both send and receive data.

High-Speed Switches

The four HSx switches (HSD1-, HSD1+, HSD2-, HSD2+) are bi-directional switches that can pass signals up to 3.6V with a VDD supply voltage in the range of 2.7V to 5.25V.

When powered with a 2.7V supply, these switches have a nominal r_{ON} of 6.5Ω over the signal range of 0V to 400mV with a r_{ON} flatness of 0.3Ω . The r_{ON} matching between the HSDx- and HSDx+ switches over this signal range is only 0.06Ω ensuring minimal impact by the switches to USB high speed signal transitions. As the signal level increases, the r_{ON} switch resistance increases. At a signal level of 3.3V the switch resistance is nominally 12Ω .

The HSx switches are specifically designed to pass USB 2.0 high-speed (480Mbps) differential signals typically in the range of 0V to 400mV. They have low capacitance and high bandwidth to pass the USB high-speed signals with minimum edge and phase distortion and thus meet USB 2.0 high speed signal quality specifications.

The HSx switches can also pass USB full-speed signals (12Mbps) with minimal distortion and meet all the USB requirements for USB 2.0 full-speed signaling.

The maximum normal operating signal range for the HSx switches is from 0V to 3.6V. For normal operation, the signal voltage should not be allowed to exceed this voltage range or go below ground by more than -0.3V.

If a positive voltage $> 3.8V$ (typ) to 5.25V, such as the USB 5V V_{BUS} voltage, gets shorted to one or both of the COM+ and COM- pins or a negative voltage $< -0.5V$ (typ) to -5V gets shorted to one or both of the COM pins, the ISL54225 overprotection circuitry (OVP) is activated. OVP allows the device to detect the overvoltage condition and open the SPDT switches to prevent damage to the USB down-stream transceivers connected at the signal pins (HS1D-, HS1D+, HS2D-, HS2D+).

The OVP and power-off protection circuitry allows the COM pins (D-, D+) to be driven up to 5.25V, while the V_{DD} supply voltage is in

the range of 0V to 5.25V. In this condition the part draws $< 100\mu A$ of I_{COMx} and I_{DD} current and causes no stress to the IC. In addition, the SPDT switches are OFF and the fault voltage is isolated from the other side of the switch. See the [ISL54225 datasheet](#) for more information on the power-off and OVP functionality.

Board Component Definitions

Evaluation board components and their functions are shown in Table 1.

TABLE 1. BOARD COMPONENT DESCRIPTIONS

DESIGNATOR	DESCRIPTION
U1	ISL54225IRTZ IC
J5	"B" Type USB Receptacle
J6, J7	"A" Type USB Receptacle
J1	VDD Positive Connection
J2	VDD Negative Connection
J4	SEL Logic Control
J3	\overline{OE} Logic Control
J8	V_{BUS} Voltage for High-speed Device 2
J9	V_{BUS} Voltage for High-speed Device 1
S1	SEL Toggle Switch
S2	\overline{OE} Toggle Switch
JP5, JP6, JP7	D-/D+ Differential Probe Connection
JP3, JP4	Host Controller (Computer) V_{BUS} Jumper
JP1	Toggle Switch S1 (SEL) Jumper
JP2	Toggle Switch S2 (\overline{OE}) Jumper

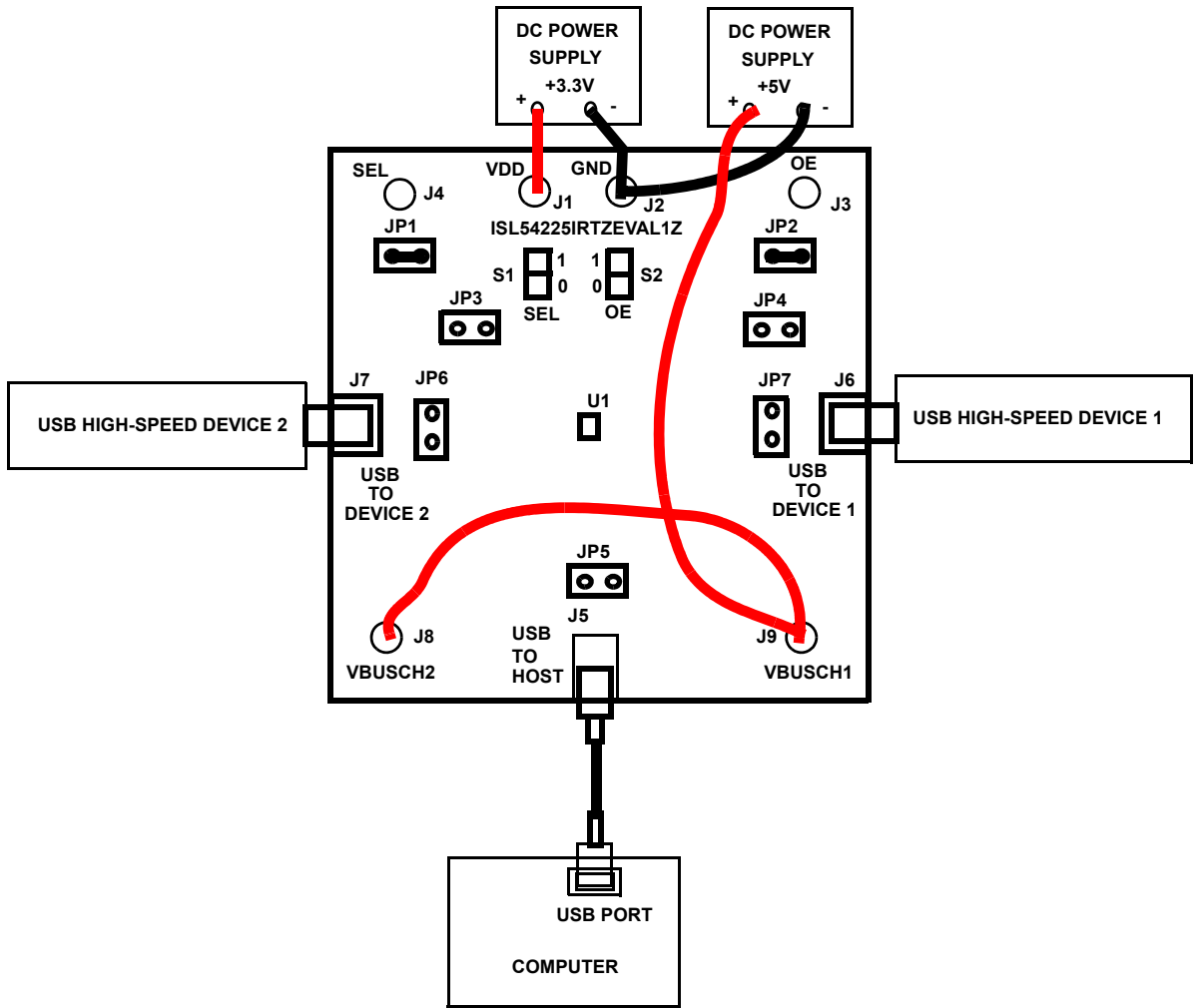

NOTE: For Device 1 to get VBUS from the computer through the J5 connector, disconnect the 5V supply from J9 and populate jumper JP4. For Device 2 to get VBUS from the computer through the J5 connector, disconnect the 5V supply from J8 and populate jumper JP3.

FIGURE 2. BASIC EVALUATION TEST SETUP BLOCK DIAGRAM

Using the ISL54225IRTZEVAL1Z Evaluation Board (see Figure 2)

Lab Equipment

The equipment, external supplies and signal sources needed to operate the board are listed below:

1. +2.7V to +5V DC Power Supply
2. +5V DC Power Supply
3. Two High-Speed USB devices (e.g., USB memory stick and MP3 player)
4. Computer with 2.0 High-Speed USB port
5. Standard USB cable

Initial Board Setup Procedure

1. Install jumpers at JP1 and JP2. Remove jumpers from JP3 and JP4.
2. Attach the main evaluation board to a DC power supply at J1 (VDD) and J2 (GND). Positive terminal at J1 and negative terminal at J2. The supply should be capable of delivering 2.7V to 5V and 100 μ A of current. Set the supply voltage to 3.3V.
3. Connect a DC power supply at J8 (VBUSHCH2) and J9 (VBUSCH1). Positive terminal at J8 and J9 and negative terminal at J2 (GND). The supply should be capable of delivering 5V and 100mA of current. Set the supply voltage to 5V. This supply provides 5V at the V_{BUS} pin of the USB "A" type connectors, J6 and J7.
4. Connect one high-speed USB device at USB connector, J6 and the other high-speed USB device at USB connector, J7. These connectors are located on the left and right sides of the evaluation board.
5. Drive the \overline{OE} control pin HIGH to open all switches of the ISL54225 IC by putting toggle switch S2 (OE) in the up position.
6. Connect the USB cable from host (computer) to the USB "B" type receptacle, J5 (USB TO HOST).

High-Speed Channel 1 Operation

1. Apply a logic LOW to the SEL pin by putting toggle switch S1 (SEL) in the down position.
2. Apply a logic LOW to the \overline{OE} pin by putting toggle switch S2 (OE) in the down position.

3. You should now be able to send and receive data between the computer and the USB Device 1, connected at J6.
4. To disconnect the USB Device 1 from the computer, take the \overline{OE} pin HIGH by putting toggle switch, S2 (\overline{OE}) in the up position.

High-Speed Channel 2 Operation

1. Apply a logic HIGH to the SEL pin by putting toggle switch, S1 (SEL) in the up position.
2. Apply a logic LOW to the \overline{OE} pin putting toggle switch, S2 (\overline{OE}) in the down position.
3. You should now be able to send and receive data between the computer and USB Device 2 connected at J7.

Test Points

The board has various test points to allow the user to connect probes to make measurements. The test points are described in Table 2.

TABLE 2. TEST POINTS

DESIGNATOR	DESCRIPTION
TP1	V _{DD} test point
TP2	Ground test point
TP3	SEL test point
TP4	\overline{OE} test point
TP6	VBUS from Pin 1 of Connector J5 test point
JP5	D-/D+ differential probe connection; COM side of switch
JP7	D-/D+ differential probe connection; Device 1 side of switch
JP6	D-/D+ differential probe connection; Device 2 side of switch

You can observe the D- and D+ USB signal of Channel 1 on an oscilloscope or other test equipment by connecting a differential probe at JP7.

You can observe the D- and D+ USB signal of Channel 2 on an oscilloscope or other test equipment by connecting a differential probe at JP6.

You can observe the D- and D+ USB signal at the COM side of the switch on an oscilloscope or other test equipment by connecting a differential probe at JP5.

ISL54225IRTZEVAL1Z Board Schematic

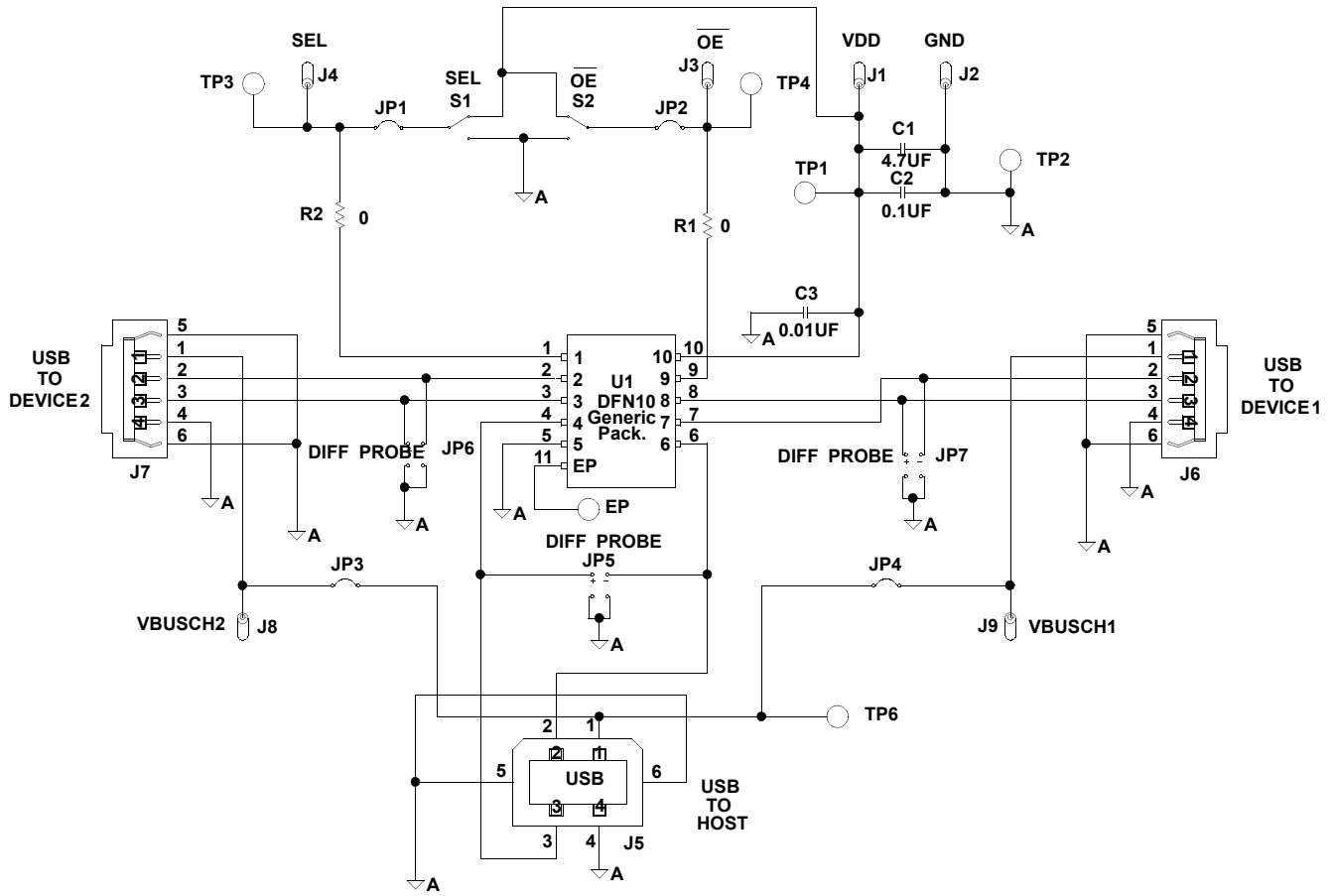

Notice

1. Descriptions of circuits, software and other related information in this document are provided only to illustrate the operation of semiconductor products and application examples. You are fully responsible for the incorporation or any other use of the circuits, software, and information in the design of your product or system. Renesas Electronics disclaims any and all liability for any losses and damages incurred by you or third parties arising from the use of these circuits, software, or information.
2. Renesas Electronics hereby expressly disclaims any warranties against and liability for infringement or any other claims involving patents, copyrights, or other intellectual property rights of third parties, by or arising from the use of Renesas Electronics products or technical information described in this document, including but not limited to, the product data, drawings, charts, programs, algorithms, and application examples.
3. No license, express, implied or otherwise, is granted hereby under any patents, copyrights or other intellectual property rights of Renesas Electronics or others.
4. You shall not alter, modify, copy, or reverse engineer any Renesas Electronics product, whether in whole or in part. Renesas Electronics disclaims any and all liability for any losses or damages incurred by you or third parties arising from such alteration, modification, copying or reverse engineering.
5. Renesas Electronics products are classified according to the following two quality grades: "Standard" and "High Quality". The intended applications for each Renesas Electronics product depends on the product's quality grade, as indicated below.
"Standard": Computers; office equipment; communications equipment; test and measurement equipment; audio and visual equipment; home electronic appliances; machine tools; personal electronic equipment; industrial robots; etc.
"High Quality": Transportation equipment (automobiles, trains, ships, etc.); traffic control (traffic lights); large-scale communication equipment; key financial terminal systems; safety control equipment; etc.
Unless expressly designated as a high reliability product or a product for harsh environments in a Renesas Electronics data sheet or other Renesas Electronics document, Renesas Electronics products are not intended or authorized for use in products or systems that may pose a direct threat to human life or bodily injury (artificial life support devices or systems; surgical implantations; etc.), or may cause serious property damage (space system; undersea repeaters; nuclear power control systems; aircraft control systems; key plant systems; military equipment; etc.). Renesas Electronics disclaims any and all liability for any damages or losses incurred by you or any third parties arising from the use of any Renesas Electronics product that is inconsistent with any Renesas Electronics data sheet, user's manual or other Renesas Electronics document.
6. When using Renesas Electronics products, refer to the latest product information (data sheets, user's manuals, application notes, "General Notes for Handling and Using Semiconductor Devices" in the reliability handbook, etc.), and ensure that usage conditions are within the ranges specified by Renesas Electronics with respect to maximum ratings, operating power supply voltage range, heat dissipation characteristics, installation, etc. Renesas Electronics disclaims any and all liability for any malfunctions, failure or accident arising out of the use of Renesas Electronics products outside of such specified ranges.
7. Although Renesas Electronics endeavors to improve the quality and reliability of Renesas Electronics products, semiconductor products have specific characteristics, such as the occurrence of failure at a certain rate and malfunctions under certain use conditions. Unless designated as a high reliability product or a product for harsh environments in a Renesas Electronics data sheet or other Renesas Electronics document, Renesas Electronics products are not subject to radiation resistance design. You are responsible for implementing safety measures to guard against the possibility of bodily injury, injury or damage caused by fire, and/or danger to the public in the event of a failure or malfunction of Renesas Electronics products, such as safety design for hardware and software, including but not limited to redundancy, fire control and malfunction prevention, appropriate treatment for aging degradation or any other appropriate measures. Because the evaluation of microcomputer software alone is very difficult and impractical, you are responsible for evaluating the safety of the final products or systems manufactured by you.
8. Please contact a Renesas Electronics sales office for details as to environmental matters such as the environmental compatibility of each Renesas Electronics product. You are responsible for carefully and sufficiently investigating applicable laws and regulations that regulate the inclusion or use of controlled substances, including without limitation, the EU RoHS Directive, and using Renesas Electronics products in compliance with all these applicable laws and regulations. Renesas Electronics disclaims any and all liability for damages or losses occurring as a result of your noncompliance with applicable laws and regulations.
9. Renesas Electronics products and technologies shall not be used for or incorporated into any products or systems whose manufacture, use, or sale is prohibited under any applicable domestic or foreign laws or regulations. You shall comply with any applicable export control laws and regulations promulgated and administered by the governments of any countries asserting jurisdiction over the parties or transactions.
10. It is the responsibility of the buyer or distributor of Renesas Electronics products, or any other party who distributes, disposes of, or otherwise sells or transfers the product to a third party, to notify such third party in advance of the contents and conditions set forth in this document.
11. This document shall not be reprinted, reproduced or duplicated in any form, in whole or in part, without prior written consent of Renesas Electronics.
12. Please contact a Renesas Electronics sales office if you have any questions regarding the information contained in this document or Renesas Electronics products.
(Note 1) "Renesas Electronics" as used in this document means Renesas Electronics Corporation and also includes its directly or indirectly controlled subsidiaries.
(Note 2) "Renesas Electronics product(s)" means any product developed or manufactured by or for Renesas Electronics.

(Rev.4.0-1 November 2017)



SALES OFFICES

Renesas Electronics Corporation

<http://www.renesas.com>

Refer to "<http://www.renesas.com/>" for the latest and detailed information.

Renesas Electronics America Inc.
1001 Murphy Ranch Road, Milpitas, CA 95035, U.S.A.
Tel: +1-408-432-8888, Fax: +1-408-434-5351

Renesas Electronics Canada Limited
9251 Yonge Street, Suite 8309 Richmond Hill, Ontario Canada L4C 9T3
Tel: +1-905-237-2004

Renesas Electronics Europe Limited
Dukes Meadow, Millboard Road, Bourne End, Buckinghamshire, SL8 5FH, U.K
Tel: +44-1628-651-700, Fax: +44-1628-651-804

Renesas Electronics Europe GmbH
Arcadiastrasse 10, 40472 Düsseldorf, Germany
Tel: +49-211-6503-0, Fax: +49-211-6503-1327

Renesas Electronics (China) Co., Ltd.
Room 1709 Quantum Plaza, No.27 ZhichunLu, Haidian District, Beijing, 100191 P. R. China
Tel: +86-10-8235-1155, Fax: +86-10-8235-7679

Renesas Electronics (Shanghai) Co., Ltd.
Unit 301, Tower A, Central Towers, 555 Langao Road, Putuo District, Shanghai, 200333 P. R. China
Tel: +86-21-2226-0888, Fax: +86-21-2226-0999

Renesas Electronics Hong Kong Limited
Unit 1601-1611, 16/F., Tower 2, Grand Century Place, 193 Prince Edward Road West, Mongkok, Kowloon, Hong Kong
Tel: +852-2265-6688, Fax: +852-2886-9022

Renesas Electronics Taiwan Co., Ltd.
13F, No. 363, Fu Shing North Road, Taipei 10543, Taiwan
Tel: +886-2-8175-9600, Fax: +886-2-8175-9670

Renesas Electronics Singapore Pte. Ltd.
80 Bendemeer Road, Unit #06-02 Hyflux Innovation Centre, Singapore 339949
Tel: +65-6213-0200, Fax: +65-6213-0300

Renesas Electronics Malaysia Sdn.Bhd.
Unit 1207, Block B, Menara Amcorp, Amcorp Trade Centre, No. 18, Jln Persiaran Barat, 46050 Petaling Jaya, Selangor Darul Ehsan, Malaysia
Tel: +60-3-7955-9390, Fax: +60-3-7955-9510

Renesas Electronics India Pvt. Ltd.
No.777C, 100 Feet Road, HAL 2nd Stage, Indiranagar, Bangalore 560 038, India
Tel: +91-80-67208700, Fax: +91-80-67208777

Renesas Electronics Korea Co., Ltd.
17F, KAMCO Yangjae Tower, 262, Gangnam-daero, Gangnam-gu, Seoul, 06265 Korea
Tel: +82-2-558-3737, Fax: +82-2-558-5338