

This document describes the setup procedure for the ISL6227 Evaluation Board DDR implementation. For information about the dual switcher application, please refer to the ISL6227EVAL2 Evaluation Board Setup Procedure.

## General Description

The ISL6227 can control two output voltages adjustable from 0.9V to 5.5V. The ISL6227 combines two synchronous PWM voltage regulators into a single IC. When the DDR pin is set to high, it transforms the IC into a complete DDR application.

Channel 1 can be set at a fixed 300kHz forced PWM mode or an automatic mode with hysteretic diode-emulation at light load and constant-frequency PWM synchronous rectification at heavy load, assure high efficiency over a wide range of conditions. Channel 2 is set at fixed 300kHz forced PWM mode with synchronous rectification because of sinking current requirement for DDR applications. Both channels use the lower MOSFET  $r_{DS(ON)}$  as the current sense element for high efficiency operations. It is preferred that the input of the second channel connects to the output of the first channel in DDR applications.

Voltage-feed-forward ramp modulation, current mode control, and internal feedback compensation provide fast response to input voltage and output load transients.

ISL6227 monitors the output voltage of CH1 only by the voltage on VSEN1 pin. PGOOD1 (power good) signal is asserted after its soft-start sequence has completed, and the output voltage within -11%/+15% of the set point. PGOOD2 pin is used to bring the VDDQ/2 into the chip as the reference voltage of the second channel error amplifier.

Built-in overvoltage protection prevents the output from going above 115% of the set point by holding the lower MOSFET on and the upper MOSFET off. When the output voltage decays below the overvoltage threshold, normal operation automatically resumes. Once the soft-start sequence has completed, undervoltage protection will latch the channel off if the output drops below 75% of its set point value. There is no overvoltage protection for Channel 2 in DDR application.

Adjustable overcurrent protection (OCP) monitors the voltage drop across the  $r_{DS(ON)}$  of the lower MOSFET. If more precise current-sensing is required, an external current sense resistor may be used. The OCP threshold can be adjusted by the resistor on OCSET pin and the current sensing gain can be adjusted by the resistor from ISEN pin to the phase node of the converter. Any overcurrent on the second channel will be reflected to the first channel. There is no OCP for the second channel.

In order to alleviate the interaction between the two channels caused by the switching noise, a phase shift has been implemented on the controller. If the input voltage is above 5V, the VIN pin should connect the input voltage. This would provide the input voltage feed forward function and command the second channel 90 degree lagging the first channel. If the input voltage is at 3.3V, the VIN pin should connect to ground. This would result in a fixed ramp for the PWM comparator and command an in-phase operation of the two channels.

## Features

- Provides regulated output voltage in the range of 0.9V–5.5V
  - High efficiency over wide load range
  - Synchronous buck converter with hysteretic operation at light load
  - Selection of hysteretic/CCM mode on channel 1. Forced CCM on channel 2 for DDR application
- Uses MOSFET  $r_{DS(ON)}$  for current sensing or uses current-sense resistor for precision overcurrent protection
- Overvoltage, undervoltage and overcurrent protection
- Undervoltage lock-out on VCC pin
- Dual input voltage mode operation
  - Operates directly from battery 5V to 24V input
  - Operates from 3.3V or 5V system rail
- Excellent dynamic response
  - Combined voltage feed-forward and current mode control
- Power-good signal for channel 1 in DDR application

## Ordering Information

PART #	TEMP. (°C)	PACKAGE	PKG DWG #
ISL6227CA	-10 to 100	28 Ld SSOP	M28.15
ISL6227CAZ (Note)	-10 to 100	28 Ld SSOP (Lead-Free)	M28.15
ISL6227CA-T	-10 to 100	28 Ld SSOP Tape and Reel	M28.15
ISL6227CAZ-T (Note)	-10 to 100	28 Ld SSOP Tape and Reel (Lead-Free)	M28.15

NOTE: Intersil Lead-Free products employ special lead-free material sets; molding compounds/die attach materials and 100% matte tin plate termination finish, which is compatible with both SnPb and lead-free soldering operations. Intersil Lead-Free products are MSL classified at lead-free peak reflow temperatures that meet or exceed the lead-free requirements of IPC/JEDEC J Std-020B.

## Pinout

ISL6227 (28 LD SSOP) TOP VIEW

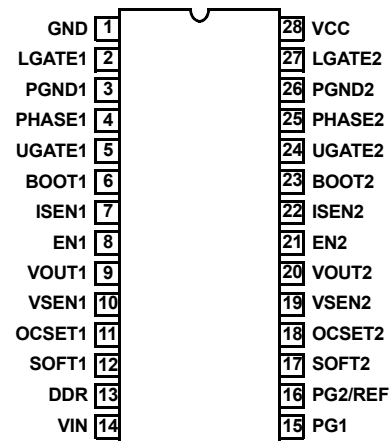

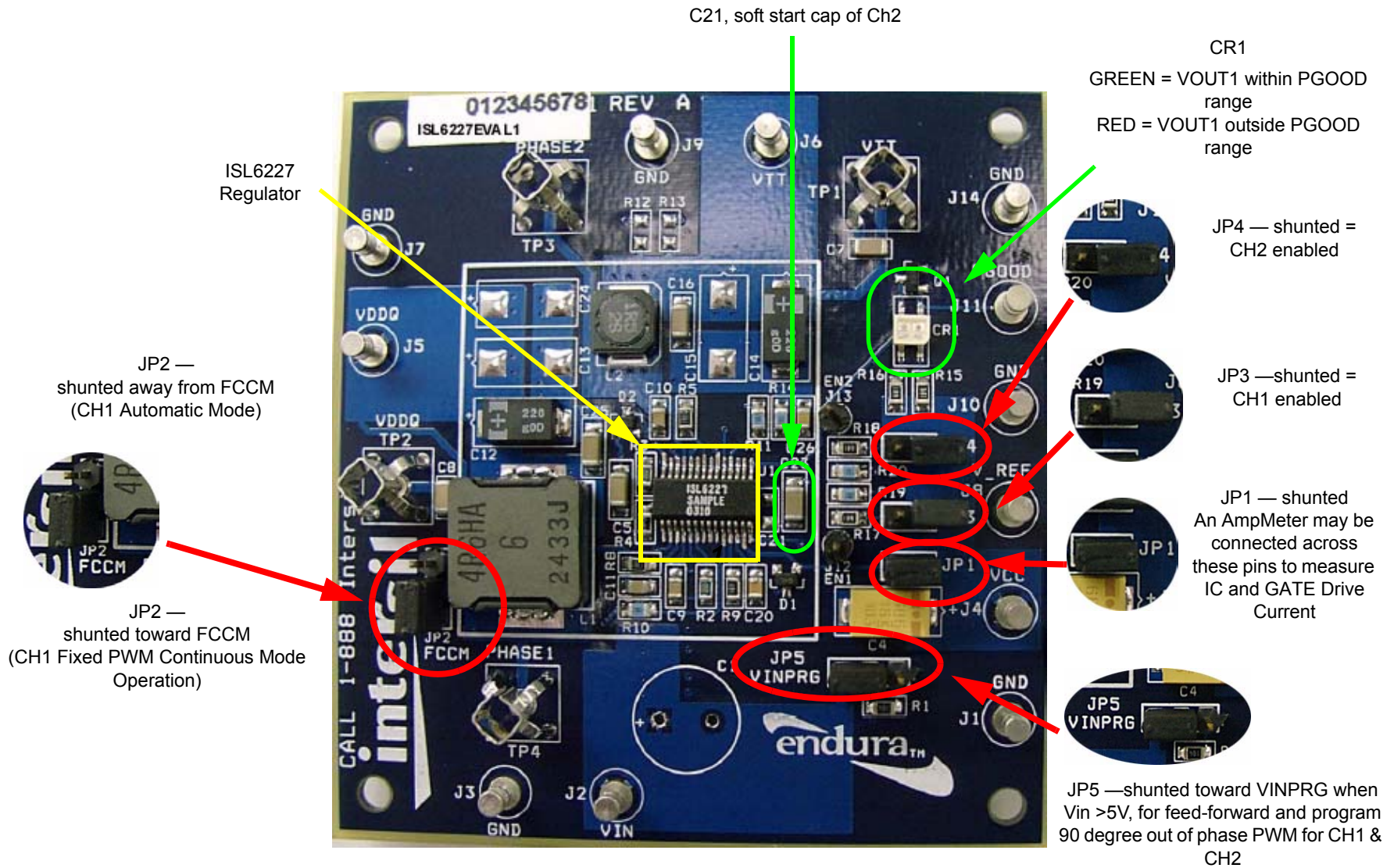

FIGURE 1. INITIAL SHUNT PLACEMENT FOR ISL6227EVAL1 (see Quick Setup)

OSCILLOSCOPE TIP MEASUREMENT POINT FOR PHASE2

Connect the negative terminal (-) of the electronic load and the negative terminal (-) of the DVM to the GND terminal J9 for ch2 (VTT)

Connect the positive terminal (+) of the electronic load and the positive terminal (+) of the DVM to the VTT terminal J6

Connect the negative terminal (-) of the electronic load and negative terminal (-) of the DVM to the GND terminal J7 for ch1 (vddq).

Connect the negative terminal (-) of the DVM to the gnd terminal J10

Connect the positive terminal (+) of the electronic load and the positive terminal (+) of the DVM to J5 VDDQ.

Connect the positive terminal (+) of the DVM to the V\_ref terminal J8

Oscilloscope tip measurement point for phase1

Set the adjustable 5v output voltage to zero volts. Connect the positive terminal (+) to the VCC terminal, and the positive terminal (+) of the DVM to J4 VCC.

Connect the negative terminal (-) of the 5VDC power supply and the negative terminal (-) of dvm and to the GND terminal J1.

Connect the negative terminal (-) of the 24VDC power supply and the negative terminal (-) of the DVM to the GND terminal J3.

Set the adjustable 24vdc output voltage to zero volts. Connect the positive terminal (+) of the adjustable 24VDC power supply and the positive terminal (+) of the dvm to VIN terminal J2.

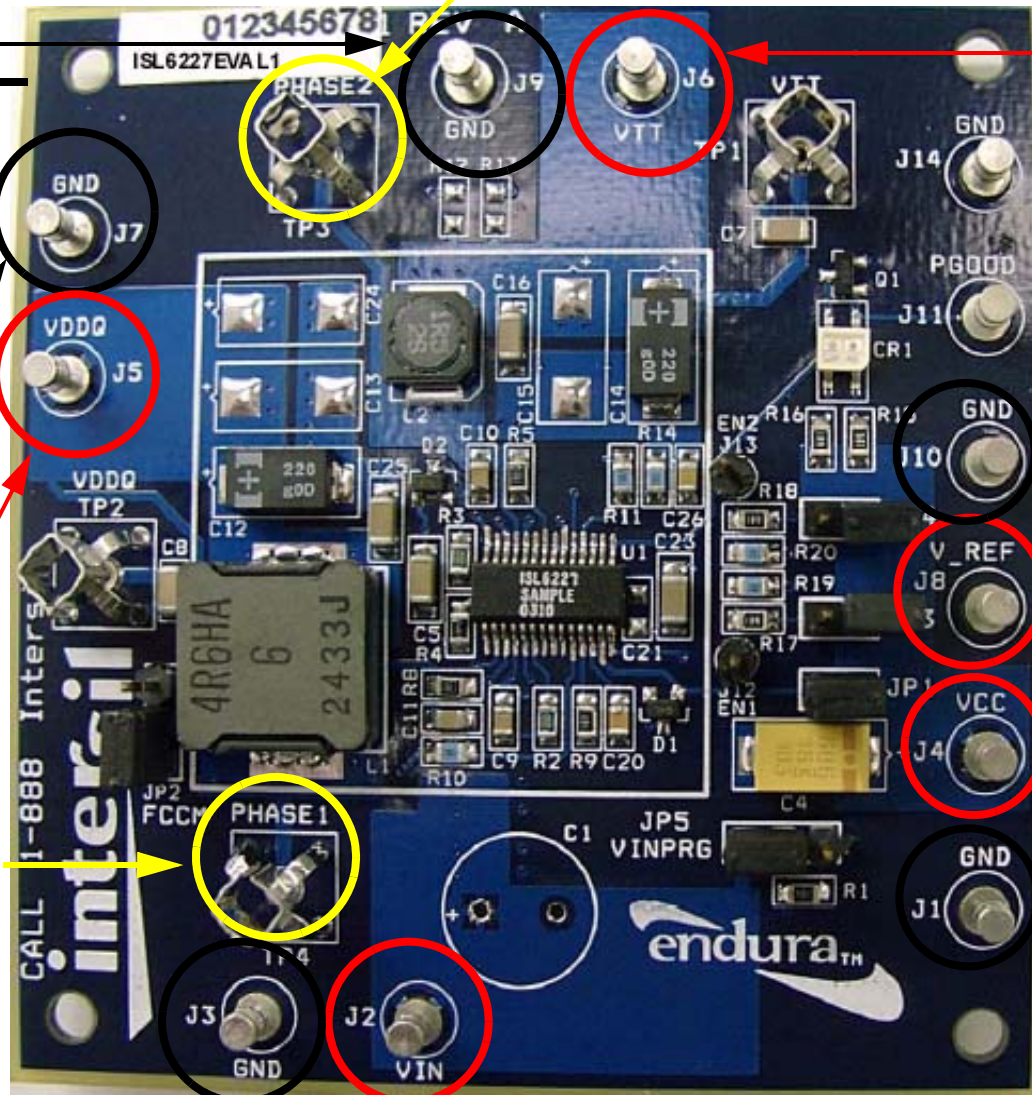

FIGURE 2. WIRING CONNECTIONS FOR ISL6227EVAL1 (see Quick Setup)

## What's Inside

This Evaluation Board Kit contains the following materials:

- the ISL6227EVAL1 Evaluation Board
- the ISL6227EVAL1 Evaluation Board Setup Procedure.

## What is Needed

The following items will be needed to perform a complete evaluation:

- 4 channel oscilloscope with probes
- 2 electronic loads
- 2 laboratory power supplies
- Precision digital multi-meters (DVM)
- Digital pulse generator

TABLE 1. Detailed Description of the Jumper Settings

Jumper	Position	Function
JP1	*Shunted	*An AmpMeter may be connected across these pins to measure IC and GATE Drive current
JP2	*FCCM	*CH1 PWM Fixed Continuous Conduction Mode Operation
	Away from FCCM	CH1 Hysteretic Operation enabled
JP3	Shunted	CH1 enabled
	* Removed	* CH1 disabled
JP4	Shunted	CH2 enabled
	* Removed	* CH2 disabled
JP5	*Toward VINPRG	* Use when $V_{in} > 5V$ , this will tie VIN pin to the input voltage for feed forward and program Ch2 PWM 90 phase lagging Ch1
	Away from VINPRG	Use when $V_{in} < 5V$ , this will tie VIN pin to GND and program in phase PWM for CH1 and CH2

NOTE \* = initial setting

TABLE 2. LED condition indicator

LED Condition	Condition	Result
CR1	green	VOUT1 WITHIN PGOOD RANGE (89%-115% of nominal value)
	red	VOUT1 OUTSIDE PGOOD RANGE (89-115% of nominal value)

## Quick Setup Note:

- The VIN Power Supply must always be the FIRST supply on and the LAST supply off to ensure start up.
- The 5V V<sub>CC</sub> Power Supply must be between 5V ± 5%.
- Make sure the power is off before moving any jumpers, except EN1 and EN2.
- Better connect/disconnect probes without powering circuit
- Make sure the electronic loads are set at 0A condition before the connection.

### Step 1: Connect power supply and measurement equipment.

#### 1a. Connect VCC power supply

- Set the output voltage of the 5V adjustable power supply to zero volts. Connect the positive terminal (+) of the power supply to the VCC terminal J4. Connect the negative terminal (-) of the 5VDC power supply to the GND terminal J1.

#### 1b. Connect VCC measurement equipment

- Connect the positive terminal (+) of a DVM to the VCC terminal J4. Connect the negative terminal (-) of the DVM to the GND terminal J1.

- Do not apply power yet

#### 1c. Connect VIN power supply

- Set the adjustable 24VDC output voltage to zero volts. Connect the positive terminal (+) of the power supply to the VIN terminals J2. Connect the negative terminal (-) of the 24VDC power supply to the GND terminal J3.

#### 1d. Connect VIN measurement equipment

- Connect the positive terminal (+) of a DVM to one of the VIN terminals J2. Connect the negative terminal (-) of the DVM to the GND terminal J3.

- Do not apply power yet

### Step 2: Connect load and measurement equipment

- 2a. Connect load for VDDQ channel and measurement equipment
  - Connect the positive terminal (+) of the electronic load and the DVM to the VDDQ terminal J5. Connect the negative terminal (-) of the electronic load and the DVM to the GND terminal J7.
- 2b. Connect load for VTT channel and measurement equipment
  - Connect the positive terminal (+) of the electronic load and the DVM to the VTT terminal J6. Connect the negative terminal (-) of the electronic load and the DVM to the GND terminal J9.
- 2c. Connect measurement equipment for VREF
  - Connect the positive terminal (+) of a DVM to the V\_REF terminal J8. Connect the negative terminal (-) of the DVM to the GND terminal J10.

### Step 3: Set control jumper as illustrated in Table 1 on page 4.

### Step 4: Power up the EVAL board

- 4a. Take the adjustable 24VDC power supply that is connected to the VIN terminals J2 and J3 and make sure the output voltage is set to zero volts.
- 4b. Turn on the 24VDC power supply.
- 4c. While reading the DVM, increase the output voltage of the 24VDC power supply to 5VDC.
- 4d. Turn on the 5VDC power supply, connected with VCC.
- 4e. While reading the DVM, increase the output voltage of the 5VDC power supply to 5VDC.

### Step 5: Take initial measurements

*(The LED should become red at this point)*

- 5a. Install the EN1 shunt jumper JP3 for CH1 (VDDQ).
- 5b. Install the EN2 shunt jumper JP4 for CH2 (VTT).
- 5c. The last action will bring LED indicator from RED to GREEN. And the PGOOD voltage on J11 should be 5V, equal to the VCC voltage.
- 5d. Read the DVM connected to the VDDQ terminal J5. It should show a value between 2.450V-2.550V
- 5e. Read the DVM connected to the VTT terminal J6. It should show a half the value of VDDQ, between 1.225V-1.275V.
- 5f. Read the DVM connected to the V\_REF terminal J8. It should read half the value of VDDQ, between 1.225-1.275V.

NOTE: A 10 nF capacitor must be installed on to C21 position if JP4 is installed prior to JP3 to ensure proper start up. C21 is the soft start capacitor for CH2, as shown in the schematics.

NOTE: Terminals J3 (EN1) and J4 (EN2) may be connected to a pulse generator for controlled on/off operation and may be observed with an oscilloscope. However, make sure the signal generator enable voltage is no more than 5V VCC.

### Step 6: Vary operating conditions

- 6a. Adjust the 24V VIN Power Supply between 5-24 VDC.
  - The VDDQ and VTT DVM readings should stay at the above reading range.
- 6b. Adjust the electronic load current level.
  - The voltage readings on VDDQ, VTT, and V\_REF should be within the above reading range. The load on VDDQ should be less than 5A with MOSFET FDS6912 mounted in the original EVAL board setup. The load on VTT should be less than 3A, and the load on V\_REF should be less than 10mA. A resistor can be connected between J8 and J10 as a load for V\_REF. The resistor value should be greater than 125 Ohm. If a larger current creating MOSFET is used, the load on VDDQ can be higher than 5A.

### Step 7: Power off

- 7a. Turn off the VCC power supply
- 7b. Turn off the VIN power supply

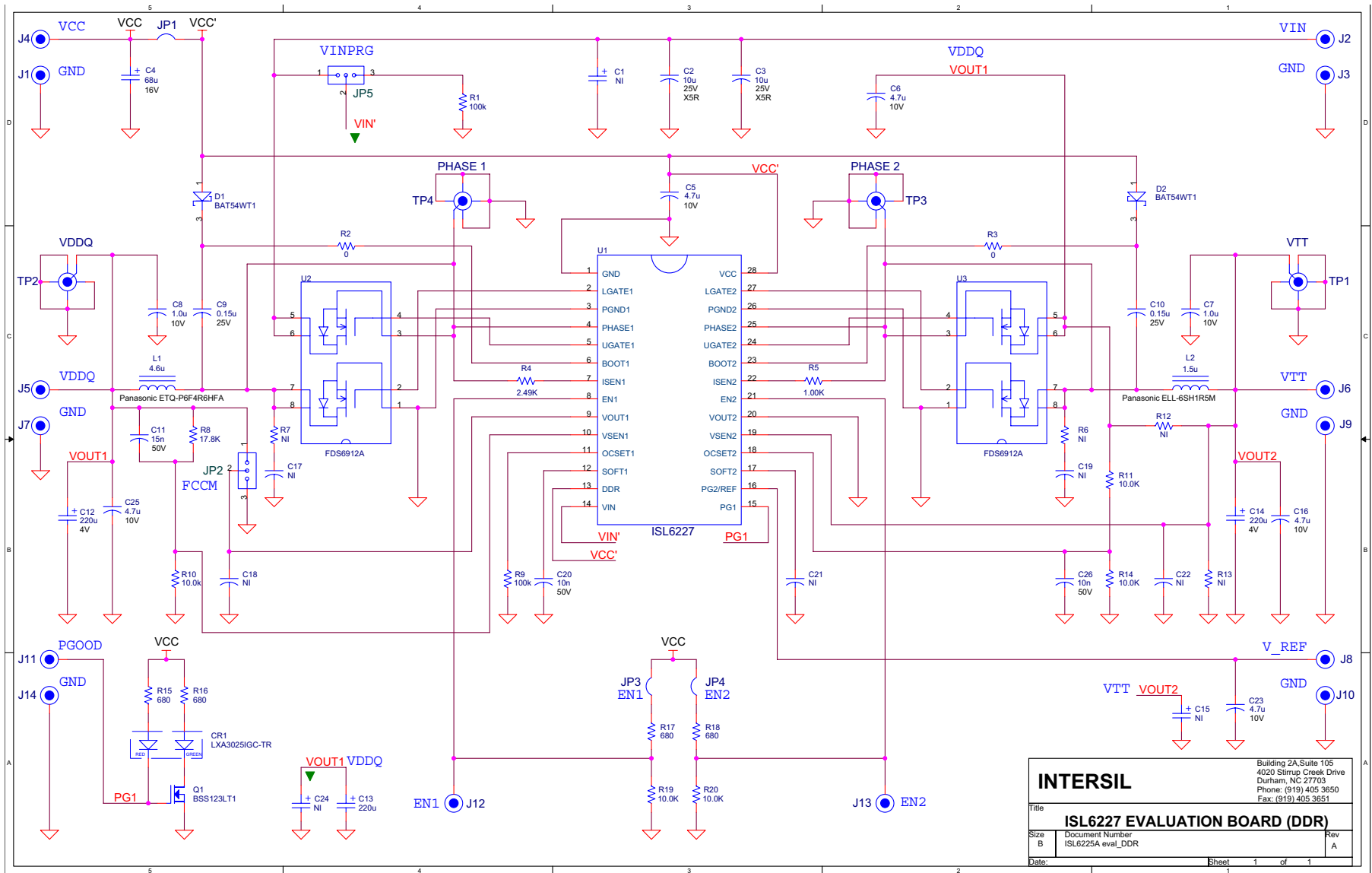

<b>INTERSIL</b>		Building 2A, Suite 105 4020 Stroup Creek Drive Durham, NC 27703 Phone: (919) 405 3650 Fax: (919) 405 3651	
<b>ISL6227 EVALUATION BOARD (DDR)</b>			
Title	ISL62277A eval_DDR		Rev A
Size B	Document Number	ISL62277A eval_DDR	
Date:	Sheet		1 of 1

FIGURE 3. ISL6227EVAL1 SCHEMATIC

## Application Note 1067

**TABLE 3. Bill of Materials (BOM)**

Qty	Reference	Description	Vendor	MFG. Part No.
1		PWB-PCB,ISL6227EVAL1,REVA	Intersil	ISL6227EVAL1PCB
1	C1	CAP, RADIAL, 220uF, 25V, 20%, ALUM, ELEC	Panasonic	EEU-FC1E221
2	C20,C26	CAPACITOR, SMD, 0805,.01uF,50V, 10%,X7R	Panasonic	ECJ-2VB1H103K
1	C11	CAPACITOR, SMD, 0805,.015uF,50V,10%,X7R	Panasonic	ECU-V1H153K
2	C9,C10	CAPACITOR, SMD,0805, 0.15uF,25V,10%, X7R	Panasonic	ECJ-2YB1E154K
2	C7,C8	CAPACITOR, SMD, 1206, 1uF,10V, 10%,X7R	Venkel	C1206X7R100-105KNE
5	C5,C6,C16,C23,C25	CAPACITOR,SMD,1206,4.7uF,10V,10%,X7R	Venkel	C1206X7R100475KNE
3	C12,C13,C14,C24	CAP TANT,LOW ESR,SMD,D3,220uF,4V,20%	Sanyo	4TPC220M
1	C4	CAP TANT,LOW ESR,SMD, D, 68uF, 16V,10%	Kemet	T49D4686K016AS
2	C2,C3	CAPACITOR,SMD,1812, 10uf, 25V,20%, X5R	Taiyo Yuden	TMK432BJ106MM-T
4	TP1-TP4	CONN-GEN,SCOPE PROBE TEST PT,COMPACT	Tektronix	131-5031-00
12	J1-J11, J14	CONN-GEN,TERMINAL POST,TH,.09 INSERTION	Keystone	1502-2
2	J12,J13	CONN-HEADER,1x1,BRKAWY 1X36,2.54mm,ST	Berg/FCI	68000-236-1X1
2	JP2,JP5	CONN-HEADER,1x3,BRKAWY 1X36,2.54mm,ST	Berg/FCI	68000-236-1X3
3	JP1,JP3,JP4	CONN-HEADER,1x2,RETENTIVE,2.54mm,ST	Berg/FCI	69190-202
5	JP1-JP5	CONN-JUMPER,2PIN,SHUNT		SPC02SYAN
2	D1,D2	DIODE-SCHOTTKYBARR,SMD,SOT323,3P,30V,.2A	ON-Semiconductor	BAT54WT1-T
1	CR1	LED,SMD,4P,OTHER,POLARIZEDRED/GRN	Lumex	SSL-LXA3025IGC-TR
1	L1	PWR CHOKE COIL, SMD, 5.7mm, 4.6uH, 25%	Panasonic	ETQ-P6F4R6HFA
1	U1	IC-DUAL SWITCHER 30V,28P,QSOP	Intersil	ISL6227CA
1	Q1	TRANSISTOR,N-CHANNEL,3P,SOT23	ON-Semiconductor	BSS123LT1-T
2	U2,U3	TRANSIST-DUAL MOS, N-CHANNEL, 8P, SOIC, 30V	Fairchild	FDS6912A
2	R2,R3	RESISTOR, SMD, 0805, 0ohm, 1/10W, TF	Panasonic	ERJ-6GEY0R00V
1	R5	RESISTOR, SMD, 0805, 1K, 1/10W, 1%, TF	Panasonic	ERJ-6ENF1001
5	R10,R11,R14,R19,R20	RESISTOR, SMD, 0805, 10K, 1/10W, 1%, TF	Panasonic	ERJ-6ENF1002V
2	R1,R9	RESISTOR,SMD, 0805, 100K, 1/10W, 1%, TF	Panasonic	ERJ-6ENF1003V
1	R8	RESISTOR,SMD, 0805, 17.8K, 1/10W, 1%, TF	Panasonic	ERJ-J6ENF1782V
1	R4	RESISTOR,SMD, 0805, 2.49K, 1/10W, 1%, TF	Panasonic	ERJ-6ENF2491
4	R15-R18	RESISTOR,SMD,0805,680ohm, 1/10W, 5%, TF	Panasonic	ERJ-6GEYJ681V
4	BAG,STATIC,5X8, ZIP LOC	BUMPONS,.44inW x .20inH,DOMETOP,, BLACK		SJ-5003-BLACK
0	C1,C15,C17,C18,C19,C21,C22,C24	DO NOT POPULATE		DNP
0	R6,R7,R12,R13	DO NOT POPULATE		DNP
1	L2	PWR CHOKE COIL,SMD,6x6x3mm,1.5uH,20% 3.2A	Panasonic	ELL6SH1R5M
1		LABEL, FOR SERIAL NUMBER AND BOM REV #		LABEL-SERIAL NUMBER

SILK SCREEN TOP

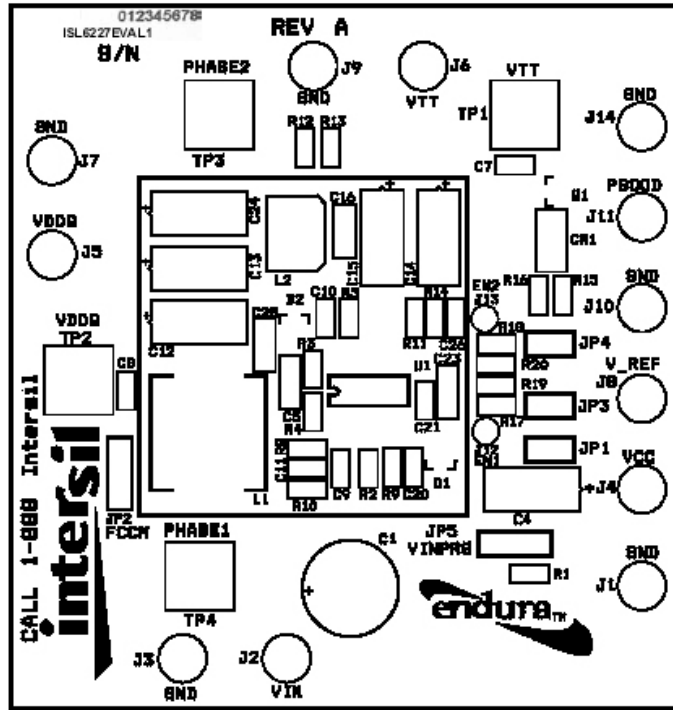

TOP LAYER

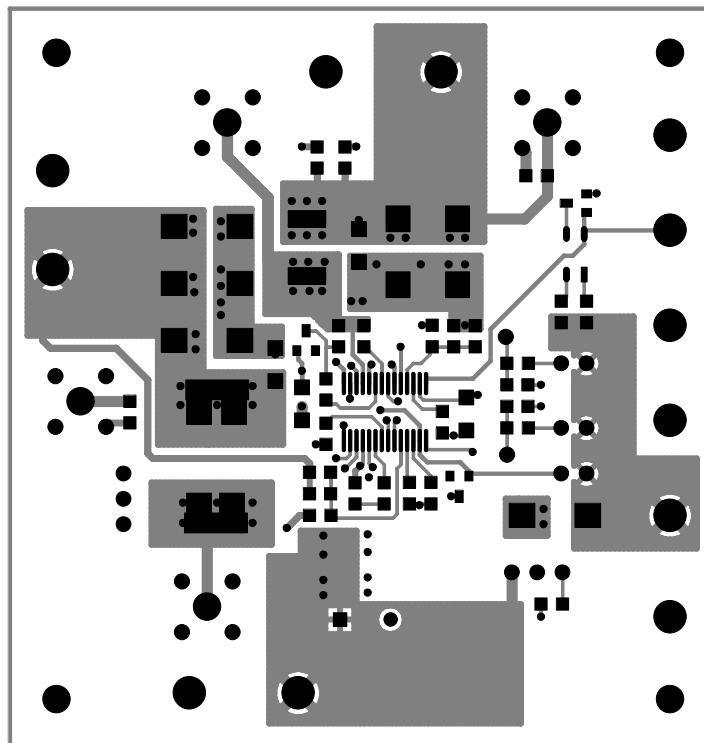



GND - INTERNAL1

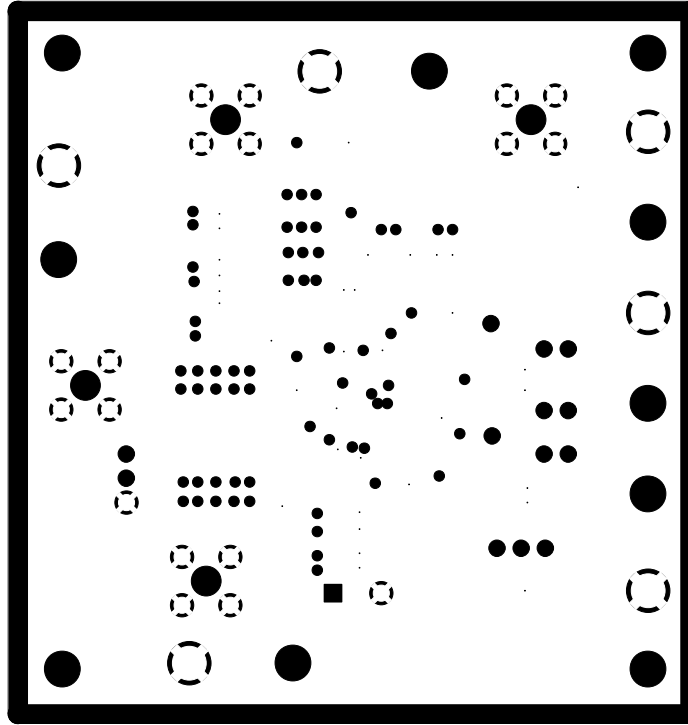

POWER - INTERNAL2

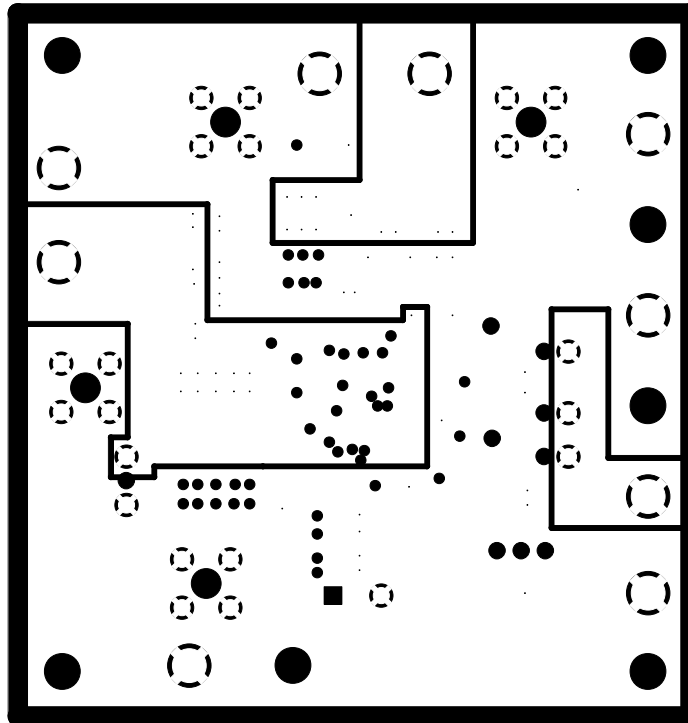

POWER - INTERNAL3

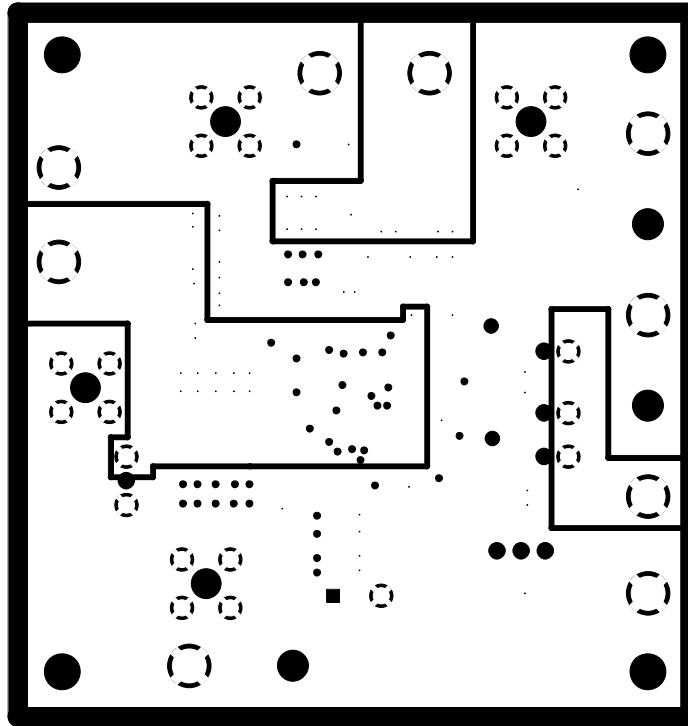

GND - INTERNAL4

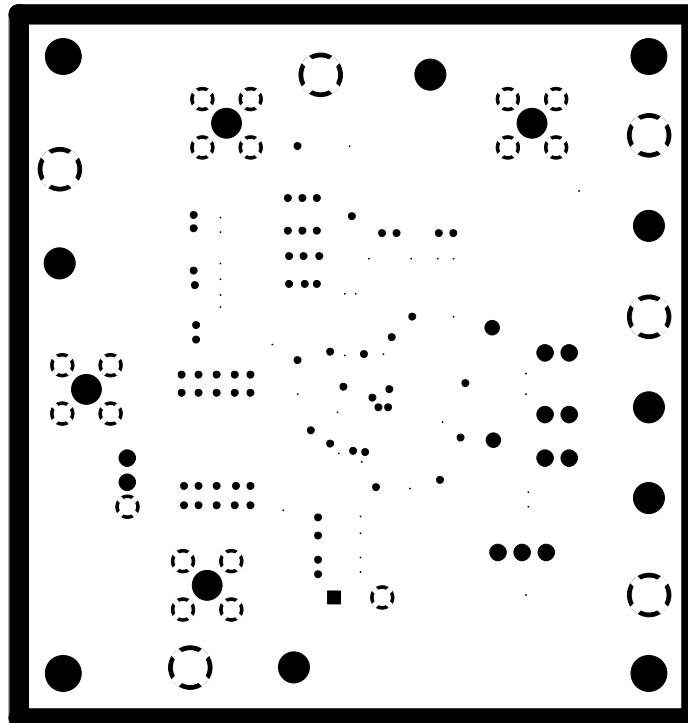

BOTTOM LAYER

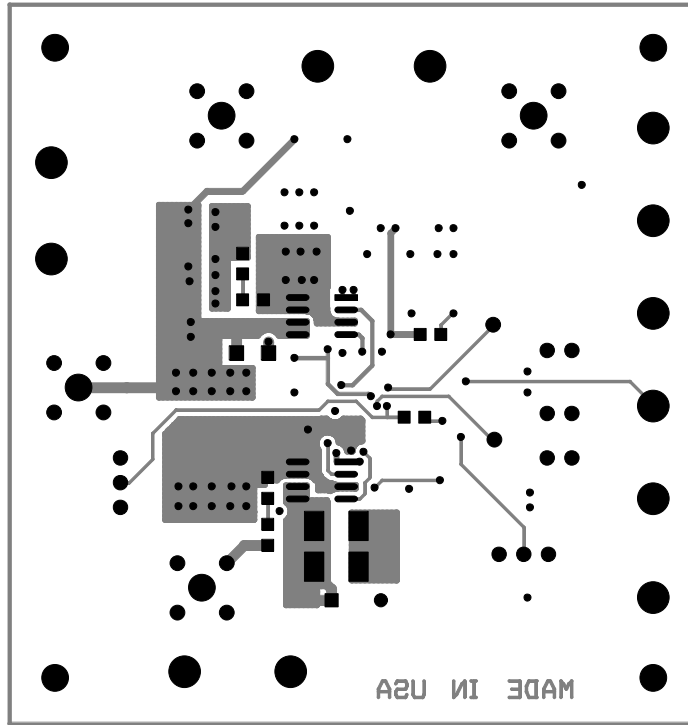

SILK SCREEN BOTTOM

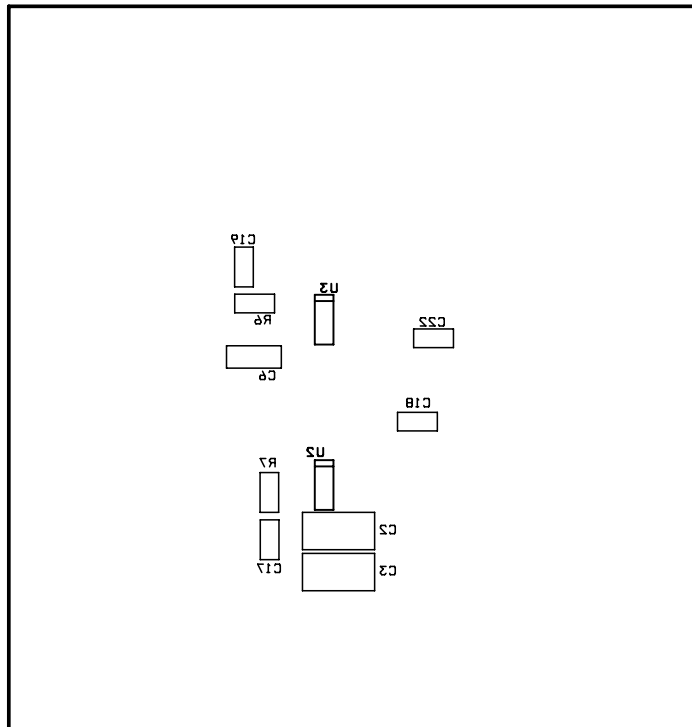

Intersil Corporation reserves the right to make changes in circuit design, software and/or specifications at any time without notice. Accordingly, the reader is cautioned to verify that the Application Note or Technical Brief is current before proceeding.

For information regarding Intersil Corporation and its products, see [www.intersil.com](http://www.intersil.com)