

NOTICE:

There are corrections pages 50 and 55 in this document.

M38000T2-CPE

User's Manual

Supported Devices:
740 Family

All information contained in these materials, including products and product specifications, represents information on the product at the time of publication and is subject to change by Renesas Electronics Corporation without notice. Please review the latest information published by Renesas Electronics Corporation through various means, including the Renesas Electronics Corporation website (<http://www.renesas.com>).

Notice

1. All information included in this document is current as of the date this document is issued. Such information, however, is subject to change without any prior notice. Before purchasing or using any Renesas Electronics products listed herein, please confirm the latest product information with a Renesas Electronics sales office. Also, please pay regular and careful attention to additional and different information to be disclosed by Renesas Electronics such as that disclosed through our website.
2. Renesas Electronics does not assume any liability for infringement of patents, copyrights, or other intellectual property rights of third parties by or arising from the use of Renesas Electronics products or technical information described in this document. No license, express, implied or otherwise, is granted hereby under any patents, copyrights or other intellectual property rights of Renesas Electronics or others.
3. You should not alter, modify, copy, or otherwise misappropriate any Renesas Electronics product, whether in whole or in part.
4. Descriptions of circuits, software and other related information in this document are provided only to illustrate the operation of semiconductor products and application examples. You are fully responsible for the incorporation of these circuits, software, and information in the design of your equipment. Renesas Electronics assumes no responsibility for any losses incurred by you or third parties arising from the use of these circuits, software, or information.
5. When exporting the products or technology described in this document, you should comply with the applicable export control laws and regulations and follow the procedures required by such laws and regulations. You should not use Renesas Electronics products or the technology described in this document for any purpose relating to military applications or use by the military, including but not limited to the development of weapons of mass destruction. Renesas Electronics products and technology may not be used for or incorporated into any products or systems whose manufacture, use, or sale is prohibited under any applicable domestic or foreign laws or regulations.
6. Renesas Electronics has used reasonable care in preparing the information included in this document, but Renesas Electronics does not warrant that such information is error free. Renesas Electronics assumes no liability whatsoever for any damages incurred by you resulting from errors in or omissions from the information included herein.
7. Renesas Electronics products are classified according to the following three quality grades: “Standard”, “High Quality”, and “Specific”. The recommended applications for each Renesas Electronics product depends on the product’s quality grade, as indicated below. You must check the quality grade of each Renesas Electronics product before using it in a particular application. You may not use any Renesas Electronics product for any application categorized as “Specific” without the prior written consent of Renesas Electronics. Further, you may not use any Renesas Electronics product for any application for which it is not intended without the prior written consent of Renesas Electronics. Renesas Electronics shall not be in any way liable for any damages or losses incurred by you or third parties arising from the use of any Renesas Electronics product for an application categorized as “Specific” or for which the product is not intended where you have failed to obtain the prior written consent of Renesas Electronics. The quality grade of each Renesas Electronics product is “Standard” unless otherwise expressly specified in a Renesas Electronics data sheets or data books, etc.
 - “Standard”:
Computers; office equipment; communications equipment; test and measurement equipment; audio and visual equipment; home electronic appliances; machine tools; personal electronic equipment; and industrial robots.
 - “High Quality”:
Transportation equipment (automobiles, trains, ships, etc.); traffic control systems; anti-disaster systems; anti-crime systems; safety equipment; and medical equipment not specifically designed for life support.
 - “Specific”:
Aircraft; aerospace equipment; submersible repeaters; nuclear reactor control systems; medical equipment or systems for life support (e.g. artificial life support devices or systems), surgical implantations, or healthcare intervention (e.g. excision, etc.), and any other applications or purposes that pose a direct threat to human life.
8. You should use the Renesas Electronics products described in this document within the range specified by Renesas Electronics, especially with respect to the maximum rating, operating supply voltage range, movement power voltage range, heat radiation characteristics, installation and other product characteristics. Renesas Electronics shall have no liability for malfunctions or damages arising out of the use of Renesas Electronics products beyond such specified ranges.
9. Although Renesas Electronics endeavors to improve the quality and reliability of its products, semiconductor products have specific characteristics such as the occurrence of failure at a certain rate and malfunctions under certain use conditions. Further, Renesas Electronics products are not subject to radiation resistance design. Please be sure to implement safety measures to guard them against the possibility of physical injury, and injury or damage caused by fire in the event of the failure of a Renesas Electronics product, such as safety design for hardware and software including but not limited to redundancy, fire control and malfunction prevention, appropriate treatment for aging degradation or any other appropriate measures. Because the evaluation of microcomputer software alone is very difficult, please evaluate the safety of the final products or system manufactured by you.
10. Please contact a Renesas Electronics sales office for details as to environmental matters such as the environmental compatibility of each Renesas Electronics product. Please use Renesas Electronics products in compliance with all applicable laws and regulations that regulate the inclusion or use of controlled substances, including without limitation, the EU RoHS Directive. Renesas Electronics assumes no liability for damages or losses occurring as a result of your noncompliance with applicable laws and regulations.
11. This document may not be reproduced or duplicated, in any form, in whole or in part, without prior written consent of Renesas Electronics.
12. Please contact a Renesas Electronics sales office if you have any questions regarding the information contained in this document or Renesas Electronics products, or if you have any other inquiries.

(Note 1) “Renesas Electronics” as used in this document means Renesas Electronics Corporation and also includes its majority-owned subsidiaries.

(Note 2) “Renesas Electronics product(s)” means any product developed or manufactured by or for Renesas Electronics.

Regulatory Compliance Notices

European Union regulatory notices

This product complies with the following EU Directives. (These directives are only valid in the European Union.)

CE Certifications:

- Electromagnetic Compatibility (EMC) Directive 2004/108/EC
EN 55022 Class A

WARNING: This is a Class A product. In a domestic environment this product may cause radio interference in which case the user may be required to take adequate measures.

EN 55024

- Information for traceability
 - Authorised representative
Name: Renesas Electronics Corporation
Address: 1753, Shimonumabe, Nakahara-ku, Kawasaki, Kanagawa, 211-8668, Japan
 - Manufacturer
Name: Renesas Solutions Corp.
Address: Nippon Bldg., 2-6-2, Ote-machi, Chiyoda-ku, Tokyo 100-0004, Japan
 - Person responsible for placing on the market
Name: Renesas Electronics Europe Limited
Address: Dukes Meadow, Millboard Road, Bourne End, Buckinghamshire, SL8 5FH, U.K.
 - Trademark and Type name
Trademark: Renesas
Product name: 740Family Compact Emulator
Type name: M38000T2-CPE

Environmental Compliance and Certifications:

- Restriction of the Use of Certain Hazardous Substances in Electrical and Electronic Equipment (RoHS) Directive 2002/95/EC
- Waste Electrical and Electronic Equipment (WEEE) Directive 2002/96/EC

WEEE Marking Notice (European Union Only)



Renesas development tools and products are directly covered by the European Union's Waste Electrical and Electronic Equipment, (WEEE), Directive 2002/96/EC. As a result, this equipment, including all accessories, must not be disposed of as household waste but through your locally recognized recycling or disposal schemes. As part of our commitment to environmental responsibility Renesas also offers to take back the equipment and has implemented a Tools Product Recycling Program for customers in Europe. This allows you to return equipment to Renesas for disposal through our approved Producer Compliance Scheme. To register for the program, click here "<http://www.renesas.com/weee>".

United States Regulatory notices on Electromagnetic compatibility

FCC Certifications (United States Only):

This equipment has been tested and found to comply with the limits for a Class A digital device, pursuant to Part 15 of the FCC Rules. These limits are designed to provide reasonable protection against harmful interference when the equipment is operated in a commercial environment. This equipment generates, uses, and can radiate radio frequency energy and, if not installed and used in accordance with the instruction manual, may cause harmful interference to radio communications. Operation of this equipment in a residential area is likely to cause harmful interference in which case the user will be required to correct the interference at his own expense.

This device complies with Part 15 of the FCC Rules. Operation is subject to the following two conditions: (1) this device may not cause harmful interference, and (2) this device must accept any interference received, including interference that may cause undesired operation.

CAUTION: Changes or modifications not expressly approved by the party responsible for compliance could void the user's authority to operate the equipment.

Preface

The M38000T2-CPE is a compact emulator with the real-time trace function for the 740 Family MCUs.

This user's manual mainly describes specifications of the M38000T2-CPE compact emulator and how to setup it. For details on the integrated development environment High-performance Embedded Workshop, 740 Compact Emulator Debugger and assembler M3T-SRA74 included with the M38000T2-CPE, refer to each product's online manual.

All the components of this product are shown in "1.1 Package Components" (page 14). If there is any question or doubt about this product, contact your local distributor.

The related manuals for using this product are listed below. You can download the latest manuals from the Renesas Tools homepage (<http://www.renesas.com/tools>).

Related manuals

Item	Manual
Integrated development environment	High-performance Embedded Workshop User's Manual
Emulator debugger	740 Compact Emulator Debugger User's Manual
Assembler	Assembler Package for 740 Family M3T-SRA740 User's Manual
C Compiler	C Compiler Package for 740 Family M3T-ICC740 User's Manual

Important

Before using this product, be sure to read this user's manual carefully.

Keep this user's manual, and refer to this when you have questions about this product.

Emulator:

The emulator in this document refers to the following products that are manufactured by Renesas Electronics Corporation:

- (1) Compact emulator main unit
- (2) Emulator MCU
- (3) Package converter board for connecting the user system

The emulator herein does not include the customer's user system and host machine.

Purpose of use of the emulator:

This emulator is a device to support the development of a system that uses the 740 Family of Renesas 8-bit single-chip MCUs.

It provides support for system development in both software and hardware.

Be sure to use this emulator correctly according to said purpose of use. Please avoid using this emulator for other than its intended purpose of use.

For those who use this emulator:

This emulator can only be used by those who have carefully read the user's manual and know how to use it.

Use of this emulator requires the basic knowledge of electric circuits, logical circuits, and MCUs.

When using the emulator:

- (1) This product is a development supporting unit for use in your program development and evaluation stages. In mass-producing your program you have finished developing, be sure to make a judgment on your own risk that it can be put to practical use by performing integration test, evaluation, or some experiment else.
- (2) In no event shall Renesas Solutions Corp. be liable for any consequence arising from the use of this product.
- (3) Renesas Solutions Corp. strives to renovate or provide a workaround for product malfunction at some charge or without charge. However, this does not necessarily mean that Renesas Solutions Corp. guarantees the renovation or the provision under any circumstances.
- (4) This product has been developed by assuming its use for program development and evaluation in laboratories. Therefore, it does not fall under the application of Electrical Appliance and Material Safety Law and protection against electromagnetic interference when used in Japan.
- (5) Renesas Solutions Corp. cannot predict all possible situations or possible cases of misuse where a potential danger exists. Therefore, the warnings written in this user's manual and the warning labels attached to this emulator do not necessarily cover all of such possible situations or cases. Please be sure to use this emulator correctly and safely on your own responsibility.

When disposing of the emulator:

Penalties may be applicable for incorrect disposal of this waste, in accordance with your national legislation.

Usage restrictions:

This emulator has been developed as a means of supporting system development by users. Therefore, do not use it as a device used for equipment-embedded applications. Also, do not use it for developing the systems or equipment used for the following purposes either:

- (1) Transportation and vehicular
- (2) Medical (equipment where human life is concerned)
- (3) Aerospace
- (4) Nuclear power control
- (5) Undersea repeater

If you are considering the use of this emulator for one of the above purposes, please be sure to consult your local distributor.

About product changes:

We are constantly making efforts to improve the design and performance of this emulator. Therefore, the specification or design of this emulator or its user's manual may be changed without prior notice.

About the rights:

- (1) We assume no responsibility for any damage or infringement on patent rights or any other rights arising from the use of any information, products or circuits presented in this user's manual.
- (2) The information or data in this user's manual does not implicitly or otherwise grant a license for patent rights or any other rights belonging to us or third parties.
- (3) This user's manual and this emulator are copyrighted, with all rights reserved by us. This user's manual may not be copied, duplicated or reproduced, in whole or part, without prior written consent of us.

About diagrams:

The diagrams in this user's manual may not all represent exactly the actual object.

Precautions for Safety

This chapter describes the precautions which should be taken in order to use this product safely and properly. Be sure to read and understand this chapter before using this product.

Contact us if you have any questions about the precautions described here.

 **WARNING** **WARNING** indicates a potentially dangerous situation that will cause death or heavy wound unless it is avoided.

 **CAUTION** **CAUTION** indicates a potentially dangerous situation that will cause a slight injury, a medium-degree injury or a property damage unless it is avoided.

In addition to the two above, the following are also used as appropriate.

△ means WARNING or CAUTION.

Example:



CAUTION AGAINST AN ELECTRIC SHOCK

⊘ means PROHIBITION.

Example:



DISASSEMBLY PROHIBITED

● means A FORCIBLE ACTION.

Example:



UNPLUG THE POWER CABLE FROM THE RECEPTACLE.

⚠ WARNING

Warnings for AC Power Supply:



- If the attached AC power cable does not fit the receptacle, do not alter the AC power cable and do not plug it forcibly. Failure to comply may cause electric shock and/or fire.
- Use an AC power cable which complies with the safety standard of the country.
- Do not touch the plug of the AC power cable when your hands are wet. This may cause electric shock.
- This product is connected signal ground with frame ground. If your developing product is transformless (not having isolation transformer of AC power), this may cause electric shock. Also, this may give an unreparable damage to this product and your developing one.
While developing, connect AC power of the product to commercial power through isolation transformer in order to avoid these dangers.
- If other equipment is connected to the same branch circuit, care should be taken not to overload the circuit.
- Use the power supply which complies with CE marking requirements.



- When installing this equipment, insure that a reliable ground connection is maintained.



- If you smell a strange odor, hear an unusual sound, or see smoke coming from this product, then disconnect power immediately by unplugging the AC power cable from the outlet.
Do not use this as it is because of the danger of electric shock and/or fire. In this case, contact your local distributor.
- Before setting up this emulator and connecting it to other devices, turn off power or remove a power cable to prevent injury or product damage.

Warnings to Be Taken for This Product:



- Do not disassemble or modify this product. Personal injury due to electric shock may occur if this product is disassembled and modified. Disassembling and modifying the product will void your warranty.
- Make sure nothing falls into the cooling fan on the top panel, especially liquids, metal objects, or anything combustible.

Warning for Installation:



- Do not set this product in water or areas of high humidity. Make sure that the product does not get wet. Spilling water or some other liquid into the product may cause unreparable damage.

Warning for Use Environment:



- This equipment is to be used in an environment with a maximum ambient temperature of 35°C. Care should be taken that this temperature is not exceeded.

CAUTION

Notes on Connecting the Power Supply of the Emulator:



- Do not use any power cable other than the one that is included with the product.
- The power cable included with the product has its positive and negative poles color-coded by red and black, respectively.
- Pay attention to the polarities of the power supply. If its positive and negative poles are connected in reverse, the internal circuit may be broken.
- Do not apply any voltages exceeding the product's rated power supply voltage (5.0 V \pm 5%). Extreme voltages may cause a burn due to abnormal heat or cause the internal circuit to break down.

Cautions to Be Taken for Turning On the Power:



- Turn ON/OFF the power of the emulator and user system as simultaneously as possible.
- Do not leave either the emulator or user system powered on, because of leakage current the internal circuits may be damaged.
- When turning on the power again after shutting off the power, wait about 10 seconds.

Cautions to Be Taken for Handling This Product:



- Use caution when handling the main unit. Be careful not to apply a mechanical shock.
- Do not touch the connector pins of the emulator main unit and the target MCU connector pins directly. Static electricity may damage the internal circuits.
- Do not pull this emulator by the communications interface cable or the flexible cable for connecting the user system. And, excessive flexing or force may break conductors.

Caution to Be Taken for System Malfunctions:



- If the emulator malfunctions because of interference like external noise, do the following to remedy the trouble.
 - (1) Press the RESET button on the emulator upper panel.
 - (2) If normal operation is not restored after step (1), shut OFF the emulator once and then reactivate it.

Cautions to Be Taken for Disposal:



Penalties may be applicable for incorrect disposal of this waste, in accordance with your national legislation.

European Union regulatory notices



Renesas development tools and products are directly covered by the European Union's Waste Electrical and Electronic Equipment, (WEEE), Directive 2002/96/EC. As a result, this equipment, including all accessories, must not be disposed of as household waste but through your locally recognized recycling or disposal schemes. As part of our commitment to environmental responsibility Renesas also offers to take back the equipment and has implemented a Tools Product Recycling Program for customers in Europe. This allows you to return equipment to Renesas for disposal through our approved Producer Compliance Scheme. To register for the program, click here "<http://www.renesas.com/weee>".

Contents

	Page
Preface.....	4
Important.....	5
Precautions for Safety	7
Contents.....	10
User Registration	12
Terminology	13
1. Outline.....	14
1.1 Package Components	14
1.2 System Configuration	15
1.2.1 System Configuration	15
1.2.2 Names and Functions of each part of the Emulator.....	16
1.3 Specifications	19
1.4 Operating Environment.....	20
2. Setup.....	21
2.1 Flowchart of Starting Up the Emulator	21
2.2 Installing the Included Software	22
2.3 Attaching the Ferrite Core	22
2.4 Connecting the Power Supply for the Emulator	23
2.5 Connecting the Host Machine	24
2.6 Turning ON the Power.....	25
2.6.1 Setting the Emulator MCU Type Selection Switch.....	25
2.6.2 Connecting the Emulator MCU	26
2.6.3 Connecting the User System	27
2.6.4 Connecting the Target Status Cables	27
2.6.5 Reset Circuit of the User System	28
2.6.6 Checking the Connections	28
2.6.7 Turning ON/OFF the Power	28
2.6.8 Power Supply to the User System	28
2.6.9 LED Display When the Emulator Starts Up Normally	29
2.7 Upgrading Firmware	30
2.7.1 When It is Necessary to Upgrade Firmware	30
2.7.2 Downloading Firmware in Maintenance Mode.....	30
2.8 Self-check.....	31
2.8.1 Self-check Procedure	31
2.8.2 If an Error is Detected in the Self-check.....	32
3. Usage (How to Use the Emulator Debugger)	34
3.1 Starting Up the Emulator Debugger	34
3.2 Checking Connections of the Emulator System	36
3.3 Setup Before Debugging	37
3.4 Program Execution	38
3.5 Hardware Breakpoint Setting Window.....	42
3.6 Trace Window.....	44
3.7 RAM Monitor Window.....	47

4. Hardware Specifications	49
4.1 Target MCU Specifications.....	49
4.2 Applicable MCU.....	50
4.2.1 Operating Condition for the 38000 Series.....	51
4.2.2 Operating Condition for the 7200 Series.....	60
4.2.3 Operating Condition for the 740 Series.....	62
4.3 Differences between the Actual MCU and Emulator	67
4.4 Connection Diagram.....	69
4.4.1 Connection Diagram of the Compact Emulator	69
4.5 Notes on Using This Product.....	70
5. Troubleshooting	73
5.1 Flowchart to Remedy the Troubles	73
5.2 When the Emulator Debugger Does Not Start Up Properly	74
5.3 How to Request for Support	76
6. Maintenance and Guarantee	77
6.1 User Registration.....	77
6.2 Maintenance	77
6.3 Guarantee.....	77
6.4 Repair Provisions	78
6.5 How to Make Request for Repair	78

User Registration

When you install debugger software, a text file for user registration is created on your PC. Fill it in and email it to your local distributor. If you have replaced an emulator main unit or emulation probe, rewrite an emulator name and serial number in the text file you filled in earlier to register your new hardware products.

Your registered information is used for only after-sale services, and not for any other purposes. Without user registration, you will not be able to receive maintenance services such as a notification of field changes or trouble information. So be sure to carry out the user registration.

For more information about user registration, please contact your local distributor.

Terminology

Some specific words used in this user's manual are defined as follows:

- **Emulator M38000T2-CPE**
This means the compact emulator (this product) for the 740 Family MCUs.
- **Emulator system**
This means an emulator system built around the M38000T2-CPE emulator. The M38000T2-CPE emulator system is configured with an emulator main unit M38000T2-CPE, emulator MCU, user system, 740 Compact Emulator Debugger and host machine.
- **740 Compact Emulator Debugger**
This means a software tool starting up from the High-performance Embedded Workshop to control the emulator for the 740 Family and enables debugging. (In this user's manual, the 740 Compact Emulator Debugger may be represented as "emulator debugger")
- **Integrated development environment High-performance Embedded Workshop**
This tool provides powerful support for the development of embedded applications for Renesas microcomputers. It has an emulator debugger function allowing for the emulator controlled from the host machine via an interface. Furthermore, it permits a range of operations from editing a project to building and debugging it to be performed within the same application. What's more, it supports version management.
- **Firmware**
This means a program stored in the flash ROM of the emulator. It analyzes contents of communication with the emulator debugger and controls the emulator M38000T2-CPE. This program is downloadable from the emulator debugger to upgrade the debugger, etc.
- **Host machine**
This means a personal computer used to control the emulator system.
- **Emulator MCU**
This means an MCU with a terminal for connecting the emulator. This is used by connected to the tip of this product (user system side).
- **Target MCU**
This means the microcomputer you are going to debug.
- **User system**
This means a user's application system using the microcomputer to be debugged.
- **User program**
This means a user's application program to be debugged.
- **#**
This symbol indicates that a signal is active-low (e.g. RESET#).

1. Outline

This chapter describes the package components, the system configuration and the preparation for using this product for the first time.

1.1 Package Components

The M38000T2-CPE package consists of the following items. When unpacking it, check to see if your M38000T2-CPE contains all of these items.

Table 1.1 Package components

Item	Quantity
M38000T2-CPE compact emulator	1
Target status cable for checking the status of Vcc and Vss and controlling the RESET signal	1
PCA4933 pitch converter board for emulator MCU	1
USB interface cable for connecting host machine and emulator	1
Power supply cable for compact emulator	1
Ferrite core for connecting power supply cable	1
M38000T2-CPE User's Manual (this manual)	1
M38000T2-CPE User's Manual (Japanese)	1
M38000T2-CPE Release Notes (English)	1
M38000T2-CPE Release Notes (Japanese)	1
CD-ROM - Integrated development environment High-performance Embedded Workshop - 740 Compact Emulator Debugger - Assembler Assembler Package for 740 Family M3T-SRA74 (evaluation version) - C Compiler C Compiler Package for 740 Family M3T-ICC740 (evaluation version)	1

* Please keep the M38000T2-CPE's packing box and cushion material in your place for reuse at a later time when sending your product for repair or other purposes. Always use these packing box and cushion material when transporting this product.

* If there is any question or doubt about the packaged product, contact your local distributor.

Note:

To our customers,

On April 1st, 2010, NEC Electronics Corporation merged with Renesas Technology Corp., and Renesas Electronics Corporation took over all the business of both companies. Therefore, although the old company name remains in this product, it is a valid Renesas Electronics product. We appreciate your understanding.

April 1st, 2010

Renesas Electronics Corporation

1.2 System Configuration

1.2.1 System Configuration

Figure 1.1 shows a configuration of the M38000T2-CPE system.

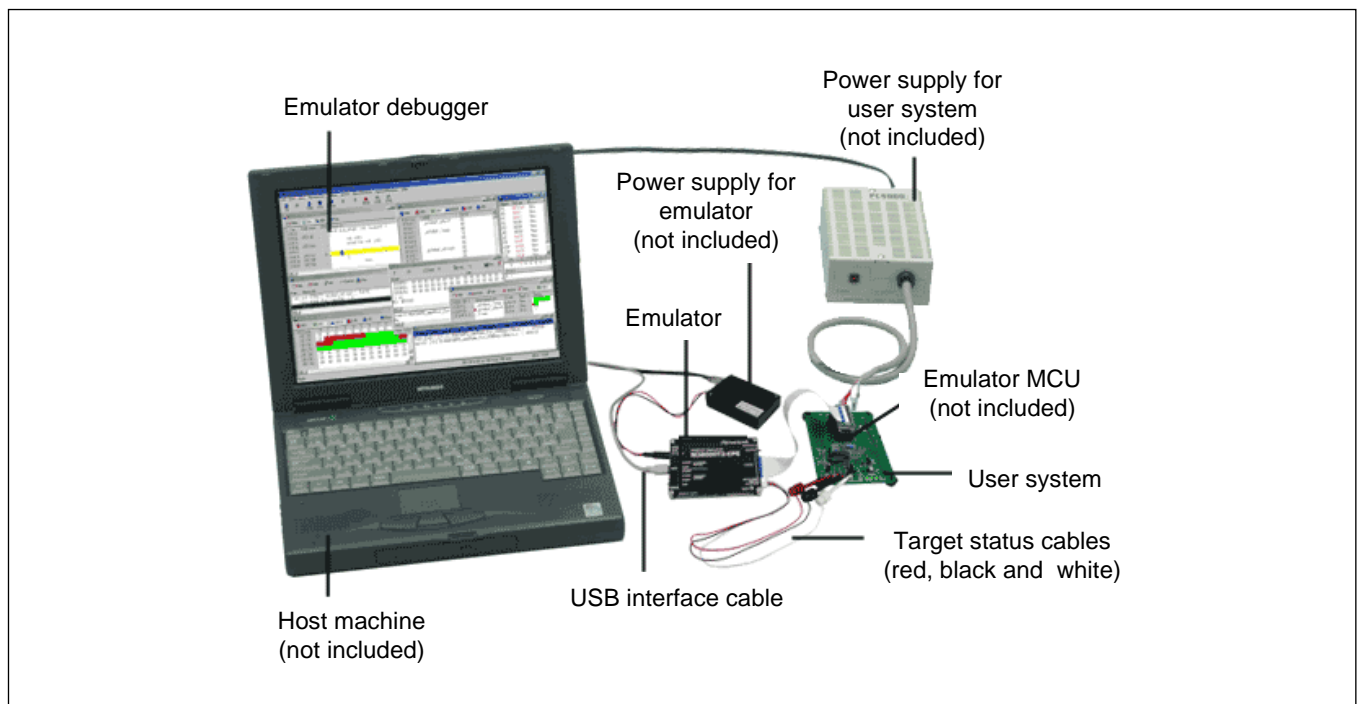

Figure 1.1 System configuration

- (1) Compact emulator M38000T2-CPE (this product)
This is a compact emulator for the 740 Family with the real-time trace functions (hereafter, emulator).
- (2) USB interface cable (included)
This is an interface cable for the host machine and the emulator.
- (3) Target status cables (included)
This is a cable for checking the status of Vcc and Vss and controlling the RESET signal.
- (4) Power supply for emulator
This is a power supply for the emulator. Supply 5.0 V \pm 5% (DC).
Prepare a power supply separately. The power cable is included with this product.
Note: Be aware that there are some AC adapters whose power supply voltage varies rather widely with its load. You are recommended to use an AC adapter with a switching power supply or a stabilized power supply.
- (5) Emulator MCU
This is an MCU dedicated for the emulator. Prepare the emulator MCU according to your MCU.
- (6) User system
This is your application system. This emulator cannot be used without the user system.
If you have no user system, you can use a temporary target board (separately available).
- (7) Power supply for User system
This is a power supply for the user system. As this emulator cannot supply the power to the user system, supply the power to the user system separately from the emulator.
- (8) Host machine
This is a personal computer for controlling the emulator.
- (9) Pitch converter board such for connecting user system
This is a pitch converter board for connecting to an MCU foot pattern on the user system. To connect the emulator MCU and user system, a converter board according to the package is required.

1.2.2 Names and Functions of each part of the Emulator

Figure 1.2 shows the names of the LEDs on the upper panel of the emulator.

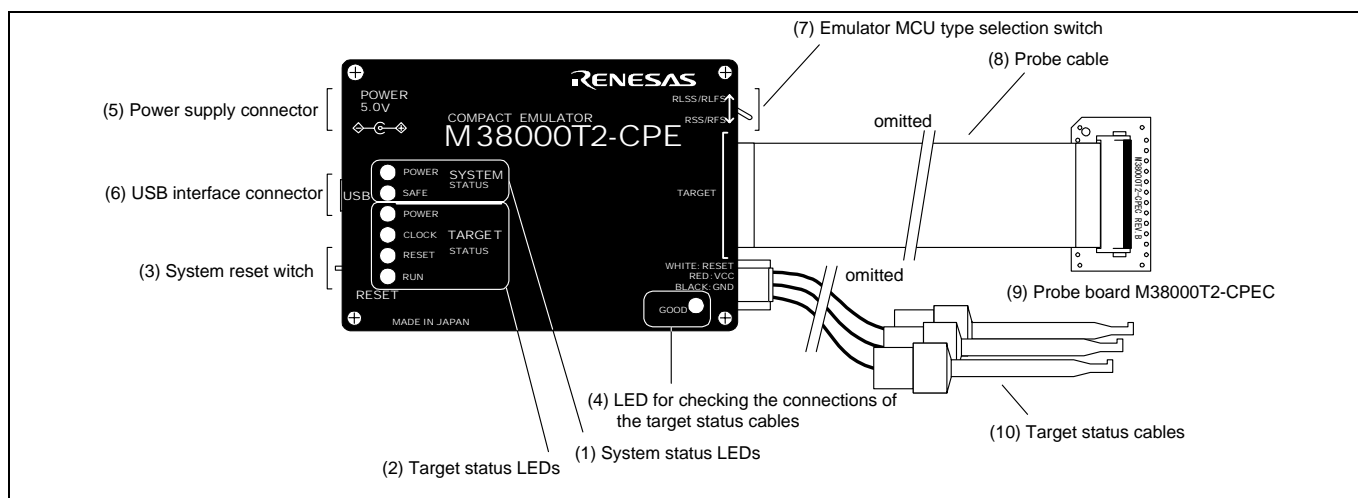

Figure 1.2 Names of the LEDs on the upper panel of the M38000T2-CPE

(1) System Status LEDs

The system status LEDs indicate the emulator main unit's operating status etc. Table 1.2 lists the definition of the system status LEDs.

Table 1.2 Definitions of the system status LEDs

Name	Number	Color	Status	Meaning
POWER	LED1	Orange	ON	Power is supplied to the emulator.
			OFF	Power is not supplied to the emulator.
SAFE	LED2	Green	ON	Emulator system has started normally.
			OFF	Emulator system has not started normally.

(2) Target Status LEDs

The target status LEDs indicate the target MCU's power supply and operating status.

Table 1.3 lists the definition of each target status LED.

Table 1.3 Definitions of the target status LEDs

Name	Number	Color	Status	Meaning
POWER	LED3	Orange	ON	Power is supplied to the emulator MCU.
			OFF	Power is not supplied to the emulator MCU.
CLOCK	LED4	Green	ON	Internal clock ϕ is output from the emulator MCU.
			OFF	Internal clock ϕ is not output from the emulator MCU.
RESET	LED5	Red	ON	Emulator MCU is being reset.
			OFF	Emulator MCU is not being reset.
RUN	LED6	Green	ON	User program is being executed.
			OFF	User program is not being executed.

(3) System Reset Switch

By pressing the system reset switch, you can initialize the emulator system.

Table 1.4 shows the functions of the system reset switch depending on the state of the emulator.

Table 1.4 Functions of the system reset switch

State of Emulator	Function
When the user's program is being stopped	Initializes the emulator and waits for a command from the emulator debugger.
When the user's program is being executed	Stops the user's program, initializes the emulator, and waits for a command from the emulator debugger.

(4) LED for Checking the Connections of the Target Status Cables

The LED (LED7) for checking the connections of the target status cables lights only when the Vcc and GND of target status cables are connected properly. When this LED does not light after turning on the emulator and user system, turn off the power immediately and check the connections of the target status cables.

However, even under normal operating conditions, when the power supply voltage is less than 3.3 V, the GOOD LED will dim or will not turn on.

Table 1.5 Definitions of the target status LEDs

Name	Number	Color	Status	Meaning
GOOD	LED7	Green	ON	VCC and GND of the target status cable are connected properly.
			OFF	VCC and GND of the target status cable are not connected properly or power is not supplied.

IMPORTANT

Notes on a System Reset:

- After pressing the system reset switch, restart the emulator debugger. Otherwise the display of emulator debugger and the actual value (in the emulator) may not match.
- When the emulator debugger does not start up normally even after rebooting, turn off the emulator and then turn on again.

(5) Power Connector (J1)

This is a connector for connecting the power supply to this product. For details, refer to “2.4 Connecting the Power Supply for the Emulator” (page 23).

(6) USB Cable Connector (J2)

This is a USB cable connector for connecting the host machine to this product. For details, “2.5 Connecting the Host Machine” (page 24).

(7) Emulator MCU type selection switch

This is a switch to select the emulator MCU type. For details, see "2.6.1 Setting the Emulator MCU Type Selection Switch" on page 25.

(8) Probe cable

This is a cable to connect the emulator MCU. The probe cable is flexible. However, excessive flexing or force may break the cable.

(9) Probe board

This is a board to connect the emulator MCU. Connect this probe board to the upper terminal of the emulator MCU.

(10) Target status cables

These are cables to monitor the VCC, GND and RESET of the user system. Connect these cables to the user system.

1.3 Specifications

Table 1.6 lists specifications of the M38000T2-CPE.

Table 1.6 M38000T2-CPE specifications

Applicable MCUs	740 Family MCUs which have emulator MCUs ^{*1}	
Usable mode	Single-chip mode Memory expansion mode Microprocessor mode	
Maximum operating frequency	10 MHz (frequency/1 mode, 0-wait)	
Minimum operating frequency	32.768 kHz (frequency/2 mode)	
Applicable power supply	When the emulator MCU is RSS or RFS type.	2.7 to 5.0 V (within the MCU's specified range)
	When the emulator MCU is RLSS or RLFS type.	1.8 to 5.0 V (within the MCU's specified range)
Emulation memory	64 KB (can be mapped by 64 bytes)	
Clock supply	Only the clock on the user system can be used.	
Basic debugging functions	<ul style="list-style-type: none"> - Download - Software break (max. 64 points, break before execution) - Program execution/stop (allows free-run execution supporting software breaks) - Memory reference/setting (reference/setting C-variables, run-time execution) - Register reference/setting - C-level debugging, etc. 	
Real-time trace function	Recording cycle	32768 cycles (Address, data, MCU status)
	Trace mode	<ul style="list-style-type: none"> - Before Break mode 32768 cycles of instruction execution before the user program stopped is recorded. - After Go mode 32768 cycles of instruction execution after an event was met is recorded.
Hardware break function	Hardware break point	1 point (Address match, bus match, max. 256 pass counts)
Execution time measurement function	Time measurement point	Time between program start and stop
	Resolution	100 ns
	Count source	Emulator timer
Real-time RAM monitor function	1,024 bytes	
Connection to user system	Via an emulator MCU and converter board prepared for each MCU.	
Power supply for emulator	DC 5.0 V \pm 5% (2 A) externally supplied (prepare the power supply separately)	
Host machine interface	USB (USB 1.1 ^{*2} full-speed, mini-B standard connector)	

*1 Applicable MCUs are occasionally updated. For more information on applicable MCUs, please visit the Renesas Tool Homepage at <http://www.renesas.com/tools>

*2 Available to connect the host machine that supports USB 2.0. With the USB interface, not all hardware (such as host machine, USB devices, USB hub) combination will work and guaranteed.

1.4 Operating Environment

Be sure to use this emulator with the operating environmental of the emulator and host machine listed in Tables 1.7 and 1.8.

Table 1.7 Operating environmental conditions

Item	Description
Operating temperature	5 to 35°C (no dew)
Storage temperature	-10 to 60°C (no dew)

Table 1.8 Operating environment of the host machine

Item	Description
Host machine	IBM PC/AT compatibles with USB1.1 ^{*2}
OS	Windows XP ^{*1} Windows 2000
CPU	Pentium III 600 MHz or more recommended
Memory	128 MB or more recommended
Pointing device such as mouse	Mouse or any other pointing device usable with the above OS that can be connected to the main body of the host machine.
CD drive	Needed to install the emulator debugger or refer to the user's manual

*1 Windows is either a registered trademark or trademark of Microsoft Corporation in the United States and other countries.

*2 Available to connect the host machine that supports USB 2.0. With the USB interface, not all hardware (such as host machine, USB devices, USB hub) combination will work and guaranteed.

2. Setup

This chapter describes the preparation for using this product, the procedure for starting up the emulator and how to change settings.

2.1 Flowchart of Starting Up the Emulator

The procedure for starting up the emulator is shown in Figure 2.1. For details, refer to each section hereafter. And, when the emulator does not start up normally, refer to “5. Troubleshooting” (page 73).

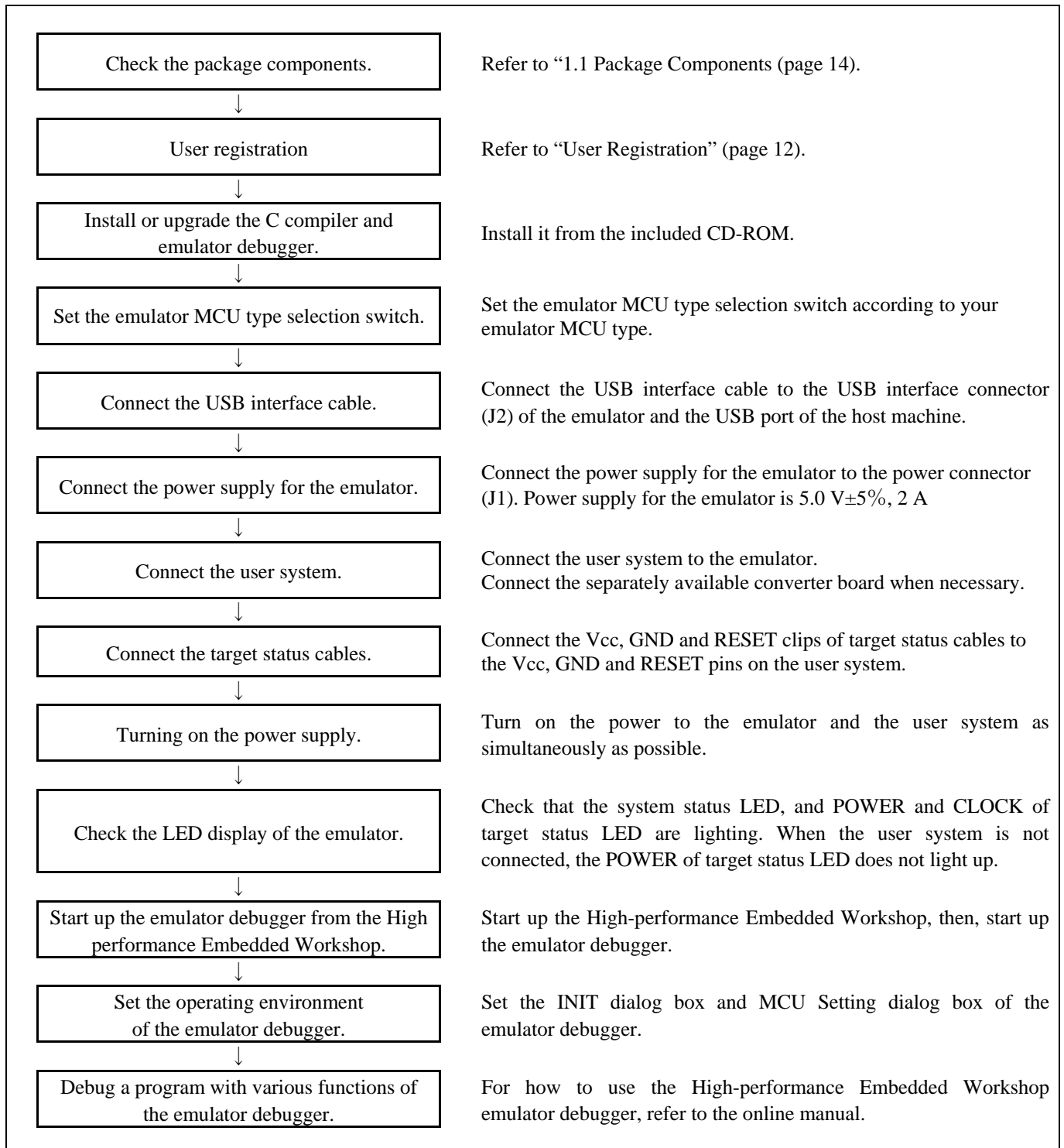

Figure 2.1 Flowchart of starting up the emulator

2.2 Installing the Included Software

If the OS used in your host machine is Windows XP or 2000, this installation must be executed by a user with administrator rights. Be aware that users without administrator rights cannot complete the installation.

The "auto_run.exe" starts up by inserting the included CD into the CD-ROM drive, and the HTML page for installation will open. Install the C compiler, emulator debugger and USB driver as occasion demands.

In process of installation, "user information" dialog box to enter the user information (contractor, section, contact address, and host machine) will open. The supplied information will be turned into a format by which technical support will be provided by e-mail.

2.3 Attaching the Ferrite Core

Attach the ferrite core included with this product close to the DC plug of the power cable. Without the ferrite core it may cause interference.

The power cable should be wound around the ferrite core as shown in Figure 2.2, and close the ferrite core until it clicks.

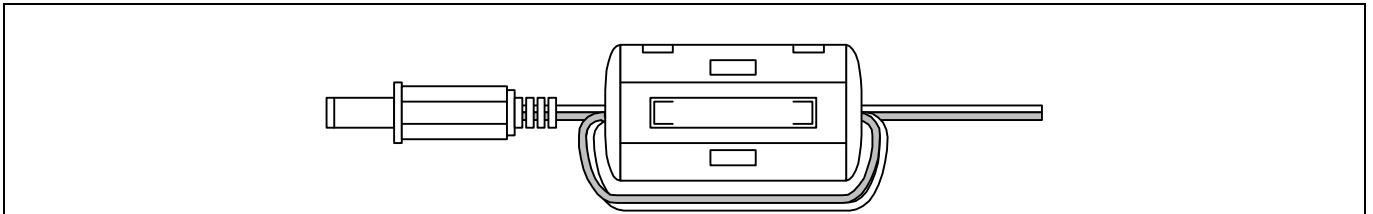

Figure 2.2 Attaching the ferrite core

2.4 Connecting the Power Supply for the Emulator

Connect the power supply for the emulator to the power connector (J1). The specification of the power supply for the emulator is listed in Table 2.1.

Table 2.1 Specification of power supply of the emulator

Power supply voltage	DC 5.0 V \pm 5%/2 A
----------------------	-----------------------

Figures 2.3 and 2.4 show the specifications of the power connector (J1) and an applicable plug, respectively.

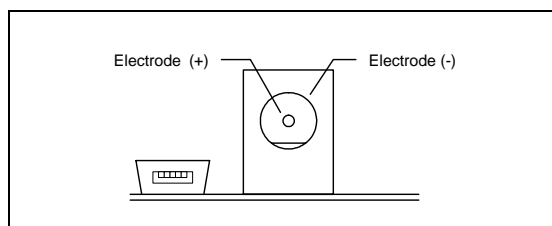

Figure 2.3 Power connector specifications

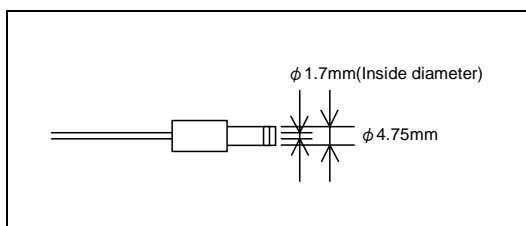

Figure 2.4 Applicable plug specifications

CAUTION

Notes on Connecting a Power Supply of the Emulator:



- The power cable included in this product package is colored red (+) and black (-).
- Be careful about the polarity of the power supply. Connecting to the wrong electrode could destroy internal circuits.
- Do not apply a voltage exceeding the specified voltage of the product (5.0 V \pm 5%), because it may cause burn injuries and the failure of internal circuits.

2.5 Connecting the Host Machine

Connect the emulator and the host machine with the USB interface cable.

Connect the USB interface cable (included) to the USB interface connector (J2) and the USB port of the host machine (see Figure 2.5).

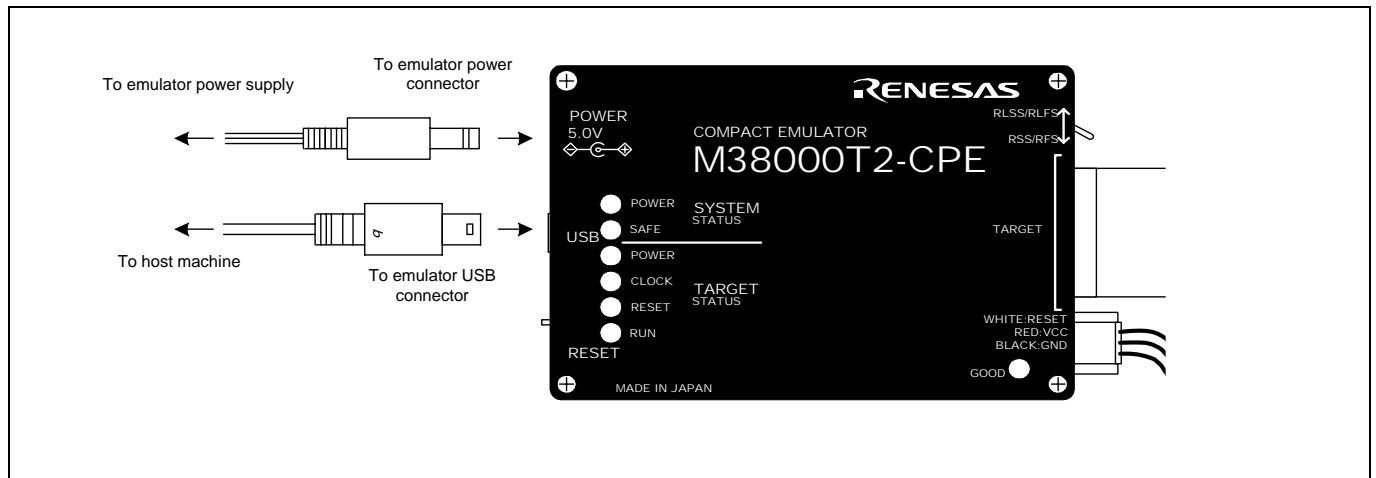

Figure 2.5 Connecting the emulator system

2.6 Turning ON the Power

2.6.1 Setting the Emulator MCU Type Selection Switch

Set the emulator MCU type selection switch according to your emulator MCU type.

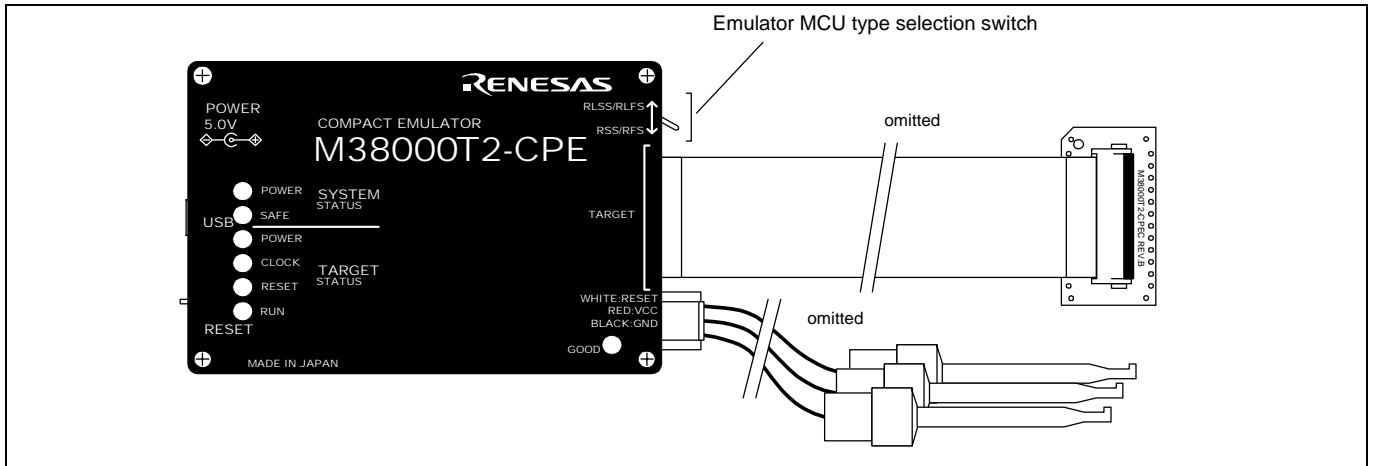

Figure 2.6 Switch locations

(1) Emulator MCU Type Selection Switch

This is the switch to select an emulator MCU type. As shown in Table 2.2 below, set the switch according to your emulator MCU type.

Table 2.2 Emulator MCU type selection switches

Switch setting	Description
	When the emulator MCU is RSS or RFS type. When using the M3xxxxRSS, M3xxxxRFS.
	When the emulator MCU is RLSS or RLFS type. When using the M3xxxxRLSS, M3xxxxRLFS.

⚠ CAUTION

Note on Switch Settings:



- Always shut OFF the emulator before changing the setting of the jumper switches, and connecting the cable. Otherwise the internal circuit may cause a break.

2.6.2 Connecting the Emulator MCU

There are two ways available to connect the emulator MCU and M38000T2-CPE according to the emulator MCU type.

(1) For RSS and RLSS Type Emulator MCU

When the emulator MCU is RSS or RLSS type, connect the tip probe M38000T2-CPEC of the M38000T2-CPE emulator to the emulator MCU directly. To connect them, align the No. 1 pins.

(2) For RFS and RLFS Type Emulator MCU

When the emulator MCU is RFS or RLFS type, connect the converter board PCA4933 (included) between the tip probe M38000T2-CPEC of the M38000T2-CPE emulator and the emulator MCU. To connect them, align the No. 1 pins.

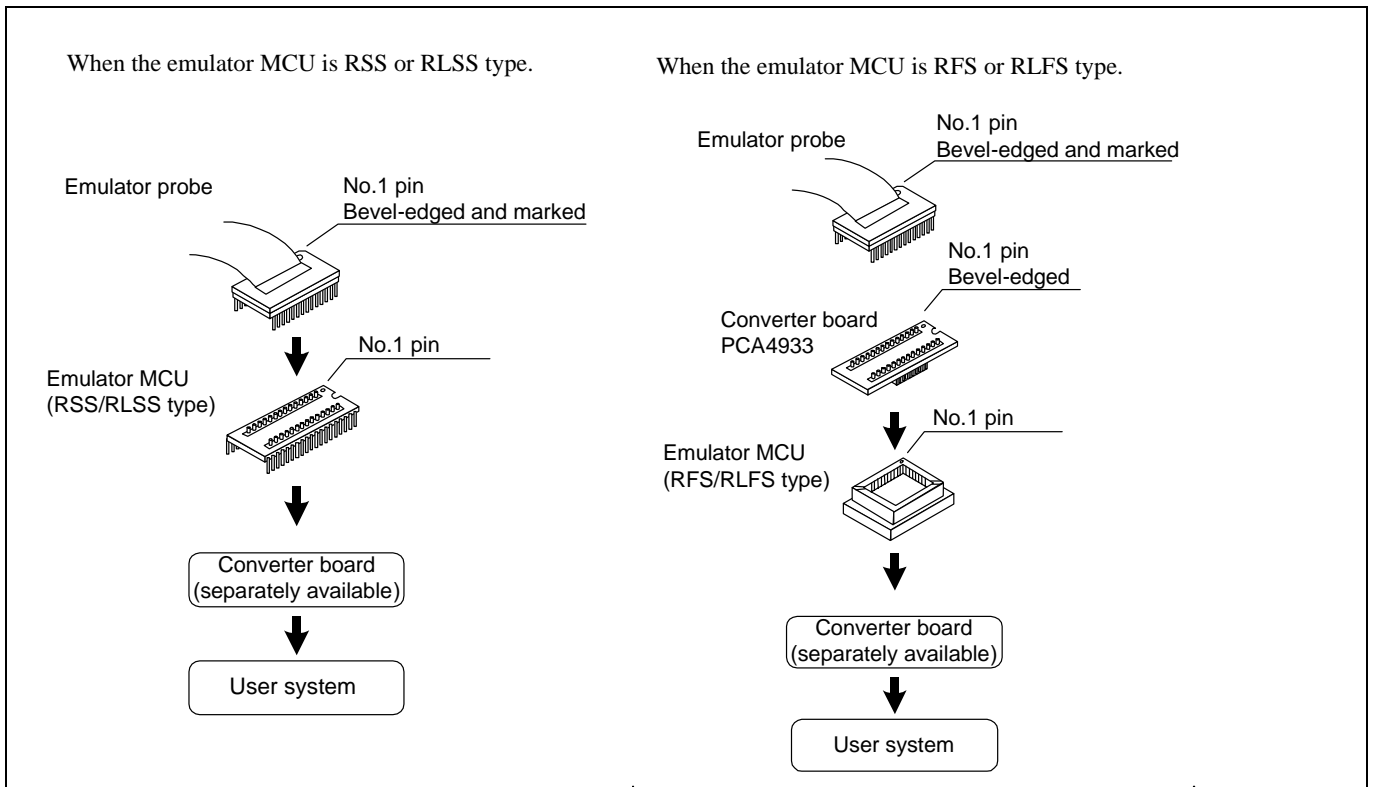

Figure 2.7 Connecting the emulator and emulator MCU

⚠ CAUTION

Notes on Connecting Emulator MCU:



- Always shut OFF the emulator and the user system when connecting and disconnecting the user system. Otherwise the internal circuit may cause a break.
- Take care not to attach the converter board in a wrong direction. It may cause a fatal damage to the compact emulator.

2.6.3 Connecting the User System

To connect the emulator MCU and user system, a converter board according to the package is required. For details on connecting to the user system, go to the M38000T2-CPE page from the following Renesas Tools Homepage and click "Options" on the left menu to select the target MCU.

<http://www.renesas.com/tools>

When you have not prepared the user system, you can use a temporary target board (separately available).

2.6.4 Connecting the Target Status Cables

Connect the VCC, GND and RESET clips on the tip of the target status cables to the VCC, GND and RESET pins of the user system respectively.

- (1) VCC cable (red)
- (2) GND cable (black)
- (3) RESET cable (white)

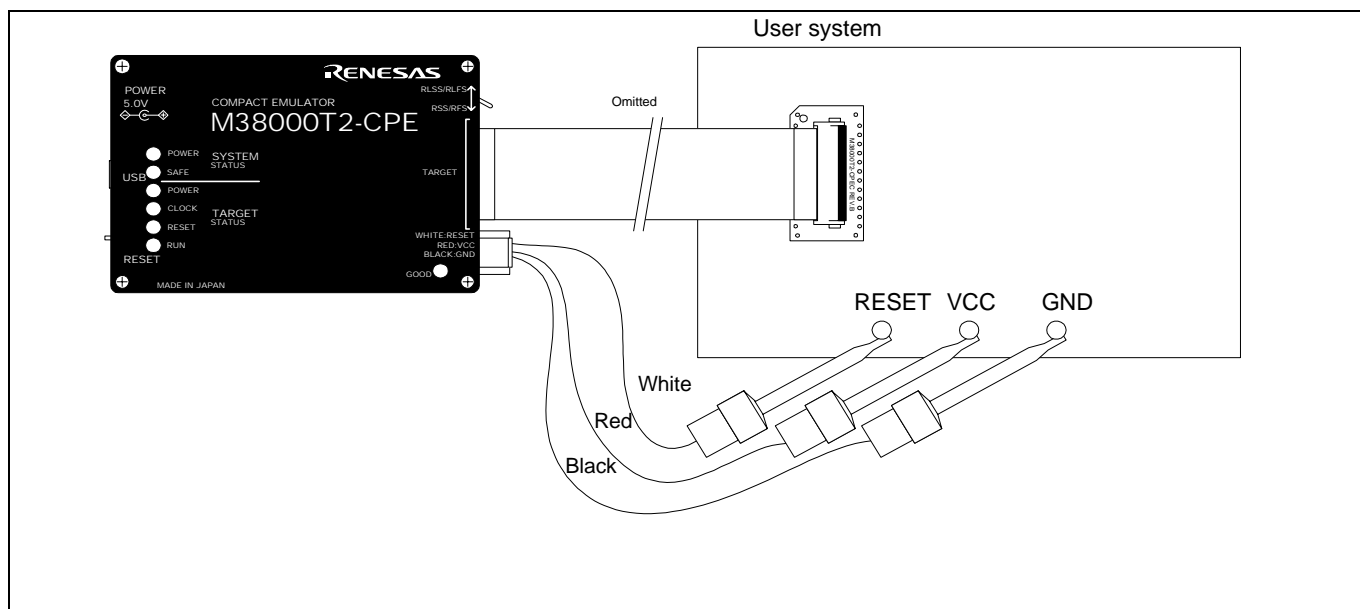

Figure 2.8 Connecting the Target Status Cables

⚠ CAUTION

Notes on Connecting the User System:



- Take care not to attach the converter board in a wrong direction. It may cause a fatal damage to the compact emulator.
- Always shut OFF the emulator and the user system when connecting and disconnecting the user system. Otherwise the internal circuit may cause a break.

2.6.5 Reset Circuit of the User System

To debug with the M38000T2-CPE, use either an open-drain type reset IC or a CR reset circuit. The recommended pull-up value is about 10 kΩ. The MCU can be reset by outputting "L" to the target through the reset clip on the M38000T2-CPE. However, if the reset circuit on the target is an H-output type RESET IC, it cannot be set to "L" and the emulator will not operate properly.

Figure 2.9 shows the internal reset circuit connection diagram of the emulator.

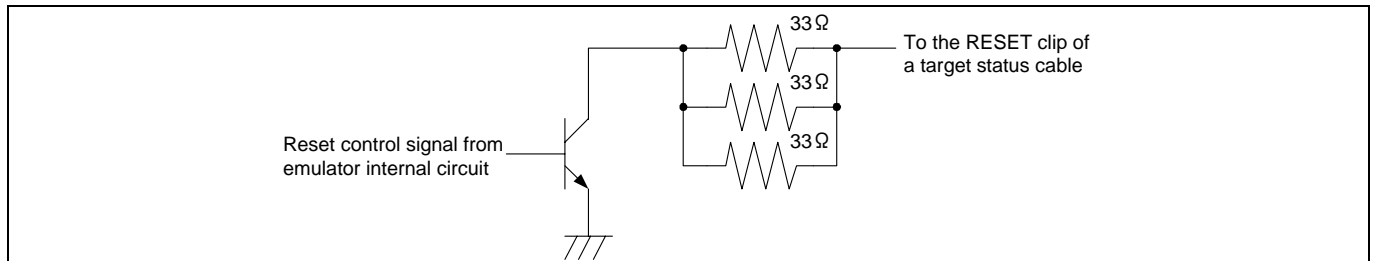

Figure 2.9 Reset circuit connection diagram

2.6.6 Checking the Connections

Before turning the power ON, check the connection of the host machine, interface cable, compact emulator and user system.

2.6.7 Turning ON/OFF the Power

Turn ON/OFF the power of the emulator and user system as simultaneously as possible.

Do not leave either the emulator or user system powered on, because of leakage current the internal circuits may be damaged.

When turning ON the power again after shutting OFF the power, wait for about 10 seconds.

2.6.8 Power Supply to the User System

This emulator cannot supply the power to the user system. Therefore design your system so that the user system is powered separately.

The voltage of the user system should be $1.8\text{ V} \leq V_{cc} \leq 5.0\text{ V}$. Do not change the voltage of the user system after turning on the power.

⚠ CAUTION

Notes on Power Supply:



- As this emulator cannot supply power to the user system, provide the user system with a separate power supply.
- This emulator consumes max. 50 mA of electrical current from user system. Therefore, set the power supply of the user system considering this consumption.
- The voltage of the user system should be within the MCU's specified range and between +1.8 to 5.0 V.
- Do not change user system power supply voltage after power has been activated.

2.6.9 LED Display When the Emulator Starts Up Normally

After the emulator starts up, check the status of the LEDs to see whether the emulator operation is enabled or not. Figure 2.10 shows the positions of the emulator status LEDs.

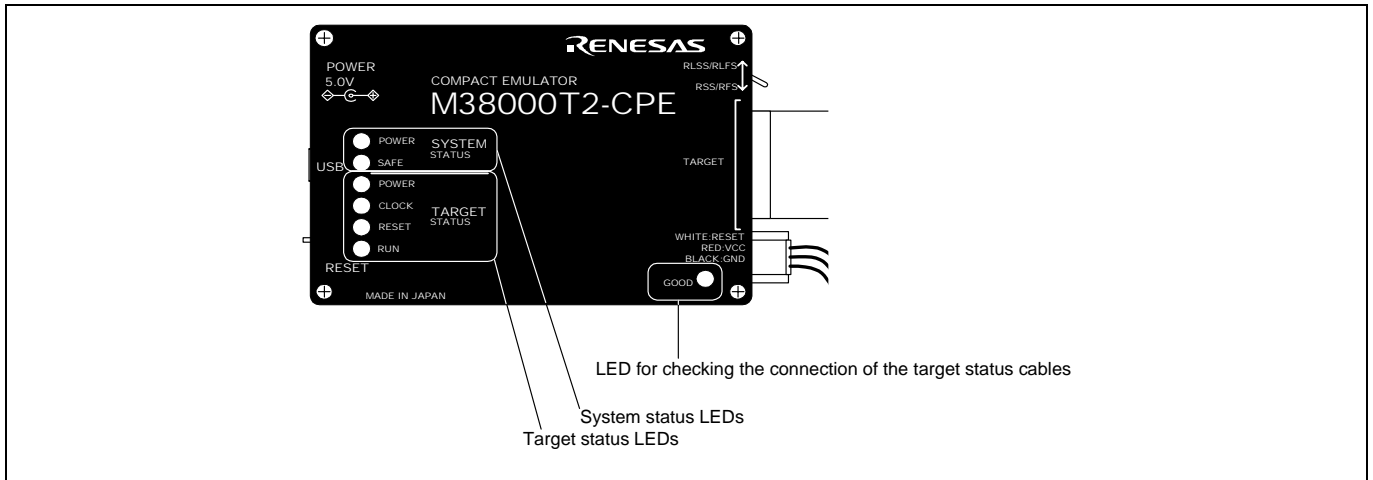

Figure 2.10 Positions of the system status LEDs and target status LEDs

(1) System status LEDs

Check that the POWER of the system status LEDs is lit immediately after the power is activated. If it is not lit, shut off the emulator and check the power supply for the emulator is properly connected.

(2) LED for checking the connections of the target status cables

Check that the LED for checking the connections of the target status cables is lit immediately after the power is activated. If it is not lit, shut off the emulator and check the target status cables are properly connected.

However, even under normal operating conditions, when the power supply voltage is less than 3.3 V, the GOOD LED will dim or will not turn on.

(3) Target status LEDs

Target status LEDs light as shown in Figure 2.11. For about 2 seconds after power is turned on, all the target status LEDs light. After that, make sure the target status LEDs light up normally.

When the target status LEDs do not display as shown in Figure 2.11, refer to “5. Troubleshooting” (page 73).

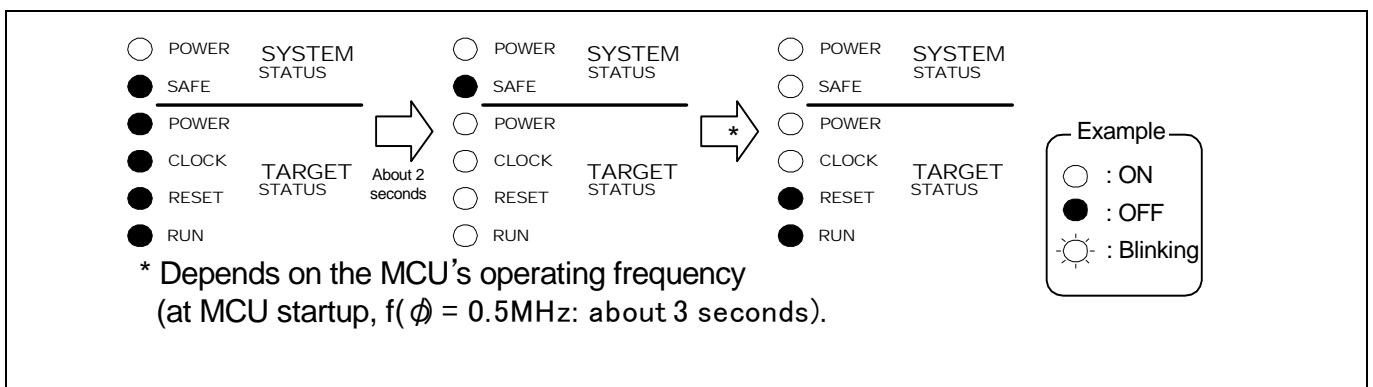

Figure 2.11 Target status LEDs display when the emulator starts up normally

2.7 Upgrading Firmware

2.7.1 When It is Necessary to Upgrade Firmware

It is necessary to upgrade the firmware in the cases listed below.

- When the firmware has been upgraded
- When the 740 Compact Emulator Debugger has been upgraded

If downloading firmware is not completed in the cases below, redownload the firmware.

- When the power is unexpectedly shut down during a download from 740 Compact Emulator Debugger
- When a communications interface cable is unexpectedly pulled out

2.7.2 Downloading Firmware in Maintenance Mode

Download firmware in the special mode called maintenance mode as explained here following.

- (1) Connect the USB interface cable to the compact emulator and host machine.
- (2) Within 2 seconds of activating power to the compact emulator, press the system reset switch on it to start maintenance mode. When the emulator is switched to maintenance mode, the System Status SAFE LED on the emulator front panel begins to flash.
- (3) Start up the 740 Compact Emulator Debugger. When settings in the Init dialog box are complete, the dialog which urges to download the firmware will appear. Download firmware following messages. Required time for downloading the firmware is about 60 seconds.

IMPORTANT

Notes on the Firmware:

- Do not shut OFF power while firmware is being downloaded. Doing so, the emulator will not start up properly. If power is shut off by mistake, redownload the firmware in maintenance mode.
- When returned to you after repair, etc., your compact emulator will have the latest version of firmware downloaded in it. If a message "Target Missing or Connection Controlled" is displayed, it means that the firmware in the emulator debugger you are using is not the latest version. So be sure to upgrade its version. The latest emulator debugger can be downloaded from the URL below.

<http://www.renesas.com/download>

2.8 Self-check

2.8.1 Self-check Procedure

The self-check is a function to check the memory etc. mounted in the emulator. The self-check is executed when the emulator starts up, and detailed check is executed by following the procedure below. Execute this self-check with the user system connected, and do so as explained here below. While the self-check is in progress, LEDs will change as shown in Figure 2.12.

- (1) Within 2 seconds of activating power to the emulator, press the system reset switch on the emulator upper panel.
- (2) Check the SAFE LED starts flashing and then press the system reset switch again.
- (3) The self-check will start. If the normal result is displayed in about 10 seconds, the self-check terminated normally.

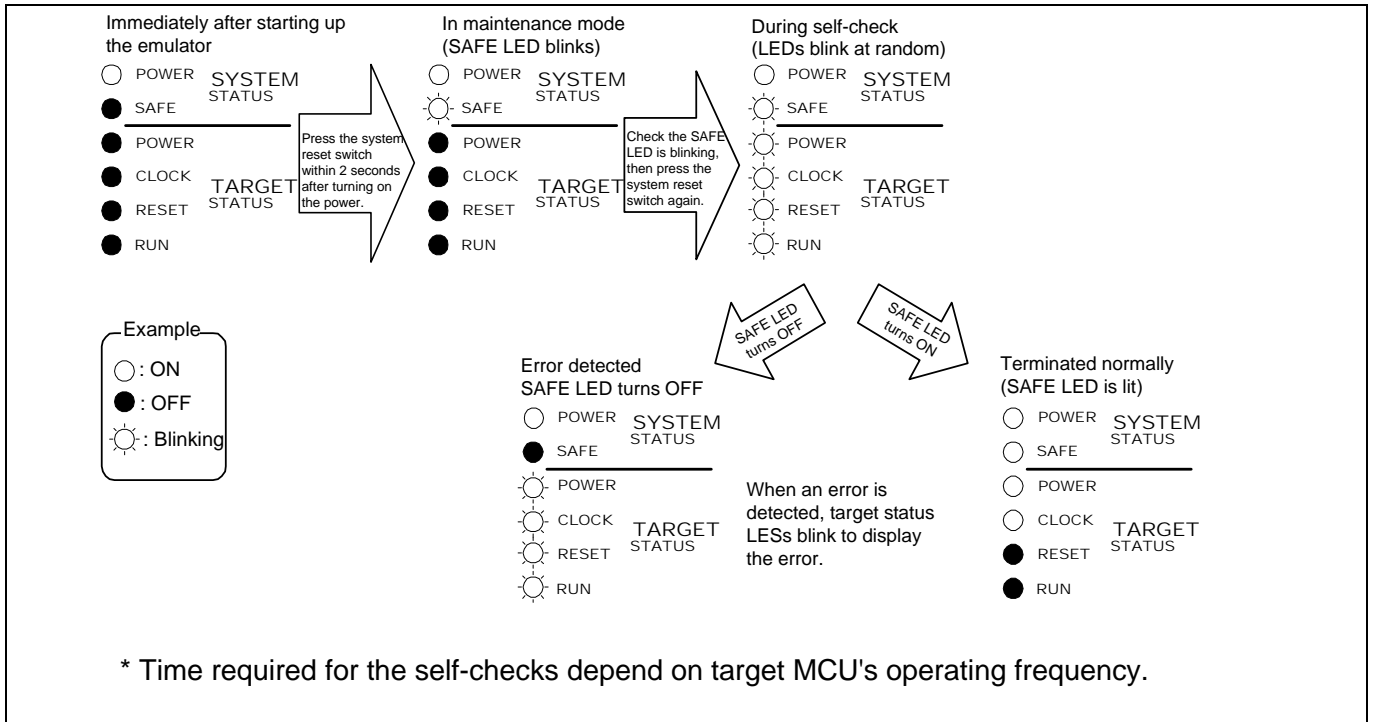

Figure 2.12 Self-check procedure

2.8.2 If an Error is Detected in the Self-check

Table 2.3 lists how to remedy the troubles if the target status LED display is abnormal in the self-check. When an error is detected, shut off the emulator and the user system and follow the steps in the Table 2.3.

Table 2.3 Error LED display in the self-check and how to remedy it (1/2)

Example				Problem & Remedy
POWER	CLOCK	RESET	RUN	
○	○	○	○	
●	●	●	●	<p>The emulator system is not working properly.</p> <ul style="list-style-type: none"> - If the SAFE LED is blinking, startup the emulator debugger and download the firmware. - Check that the emulator is powered. - The emulator may be damaged. Contact your local distributor.
●	●	●	☉	<p>The user system is not powered or the target status cables are not connected properly.</p> <ul style="list-style-type: none"> - Check that the emulator is powered. - Check that the VCC and GND clips of target status cables are connected properly. - Check that the emulator MCU type selection switch is set properly. - Check that the probe board and the user system are connected properly.
●	●	☉	●	<p>The emulator MCU type selection switch is not set properly.</p> <ul style="list-style-type: none"> - Check that the VCC and GND clips of target status cables are connected properly. - Check that the probe board and the user system are connected properly.
●	●	☉	☉	<p>The target status cables are not connected properly.</p> <ul style="list-style-type: none"> - Check that the VCC and GND clips of target status cables are connected properly.
●	☉	●	●	<p>The reset command is not executed properly.</p> <ul style="list-style-type: none"> - Check that the reset pin is not held "H". - Check that the "H" output type reset IC is not used in the reset circuit. With this emulator, the "H" output type reset IC cannot be used. - Check that the RESET clip of a target status cable is connected properly.
●	☉	●	☉	<p>The internal clock ϕ output is not executed properly.</p> <ul style="list-style-type: none"> - Check that the power supply voltage of the user system is within the MCU's specified range. - Check that the oscillating frequency of the user system is within the MCU's specified range.
●	☉	☉	●	<p>The reset command cannot be canceled properly.</p> <ul style="list-style-type: none"> - Check that the reset pin is not held "L". - Check that the pullup resistor of about 10 kΩ is connected to the reset circuit.

Table 2.4 Error LED display in the self-check and how to remedy it (2/2)

Example ○ : ON ● : OFF ☼ : Blinking				Problem & Remedy
POWER	CLOCK	RESET	RUN	
●	☼	☼	☼	The emulator system is not working properly. - The emulator or emulator MCU may be damaged. Contact your local distributor.
☼	●	●	●	
☼	●	●	☼	
☼	●	☼	●	
☼	●	☼	☼	
☼	☼	●	●	
☼	☼	●	☼	

IMPORTANT

Notes on the Self-check:

- **Be sure to connect the user system** before executing the self-check.
- If the self-check does not result normally, the emulator or emulator MCU may be damaged. Then, contact your local distributor.
- Depending on the MCU type, the registers will be altered only once after power-on. In that case, temporarily turn off the power for the emulator system and user system after self-check has finished normally and then turn it back on again.

3. Usage (How to Use the Emulator Debugger)

This chapter describes how to start up the emulator debugger from the High-performance Embedded Workshop.

3.1 Starting Up the Emulator Debugger

When debugging the completed programs, switch the session. The session can be changed by the drop down list of the tool bar shown below.



You will have as many sessions created as the number of targets you selected when creating a project, so select the session that corresponds to the target to be connected from the drop-down list. To connect to the M38000T2-CPE Compact Emulator, select “Session740_Family_Compact”

(1) MCU tab

1. Specifying the MCU file

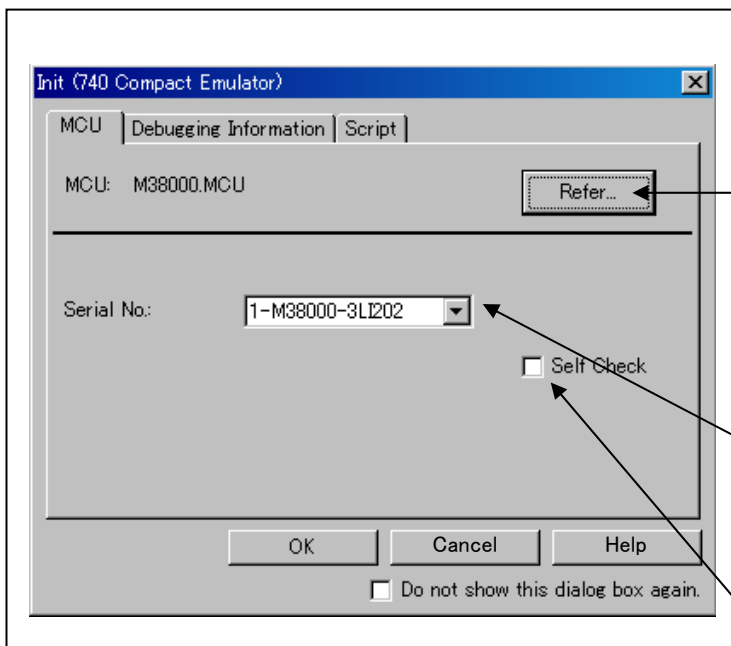

Specifying the MCU file
 Click the “Refer...” button.
 A file selection dialog box will be displayed, so select the desired MCU file. The MCU file is stored in the directory in which you installed the High-performance Embedded Workshop.
 (Example: C:\Program Files\Renesas\Hew\Tools\Renasas\DebugComp\Platform\PDTarget\PD38M\McuFiles)
 - The MCU file contains the information specific to the target MCU.
 - The MCU file you have selected is displayed in the MCU section of the MCU tab.

Serial No.
 Shows the currently connected emulators in list form. Select the serial No. of the emulator you want to be connected.

Executing the self-check
 Enable this function when you want the emulator to be self-checked at startup. Be sure to select the check box only when you want the emulator to be self-checked at startup.
 This function may be enabled in the following cases:
 - When you successfully download the firmware, but fail to start up the emulator
 - When you want to confirm whether the emulator is operating normally because, for example, the MCU runs out of control.
 This function can be enabled only when you are starting up the emulator debugger.
 For details on the self-check, refer to “2.8 Self-check” on page 31.

(2) Debugging Information tab

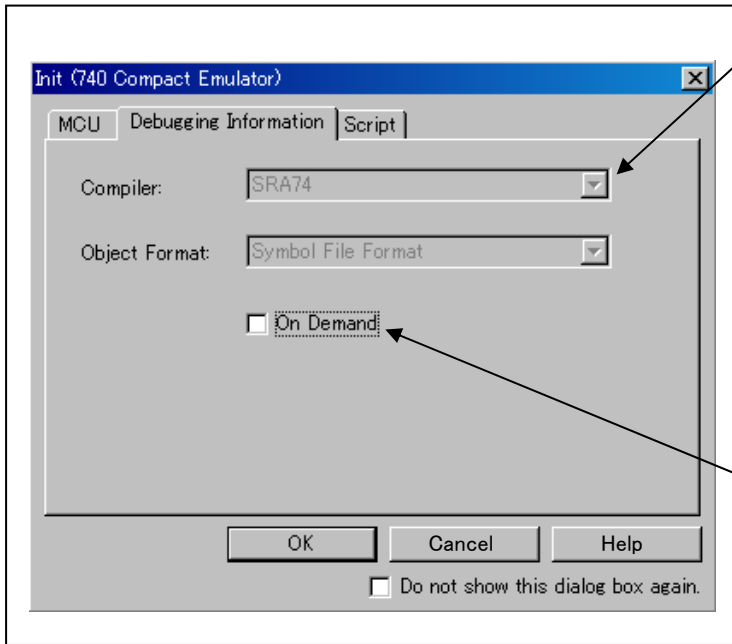

Specifying the compiler used and the object format

Specify the compiler you are using and the format of the object file output by the compiler.

- Compiler
Select the compiler or assembler you are using. (By default, the assembler from Renesas is selected.)
- Object Format
Select the format of the object file that is output by the compiler or assembler you are using.

Specifying the method for storing debug information

Select the method for storing debug information. (By default, the on memory is selected)

When selecting the on demand method, check the [On Demand] check box.

- On Memory
Debugging information is stored in the internal memory of your computer. This method is suitable when the load module (user program) size is small.
- On Demand
Debugging information is stored in a reusable temporary file on the hard disk of your computer. Because the stored debugging information is reused, the next time you download the same load module it can be downloaded at high speed. This method is suitable when the load module (user program) size is large.

(3) Script tab

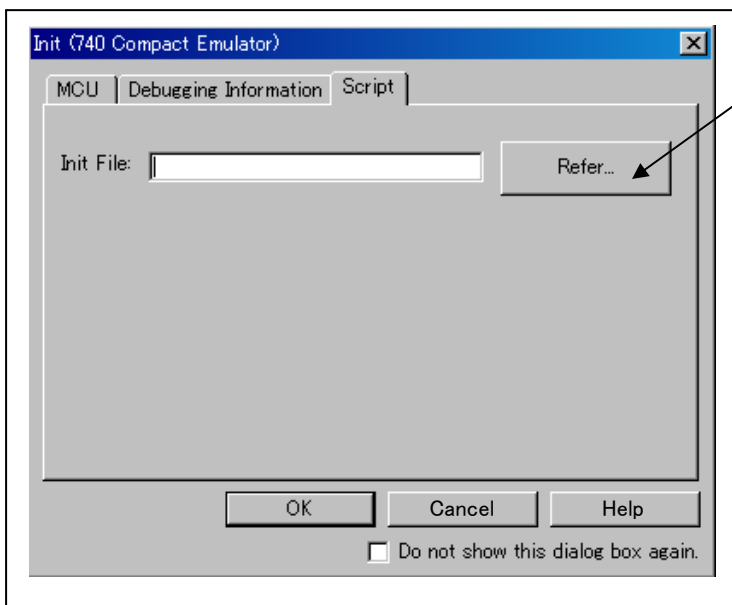

Automatically executing a script command

To automatically execute a script command when starting up the debugger, click the "Refer..." button and specify the script file to be executed.

3.2 Checking Connections of the Emulator System

Check to see that the emulator debugger has been connected correctly to the emulator.

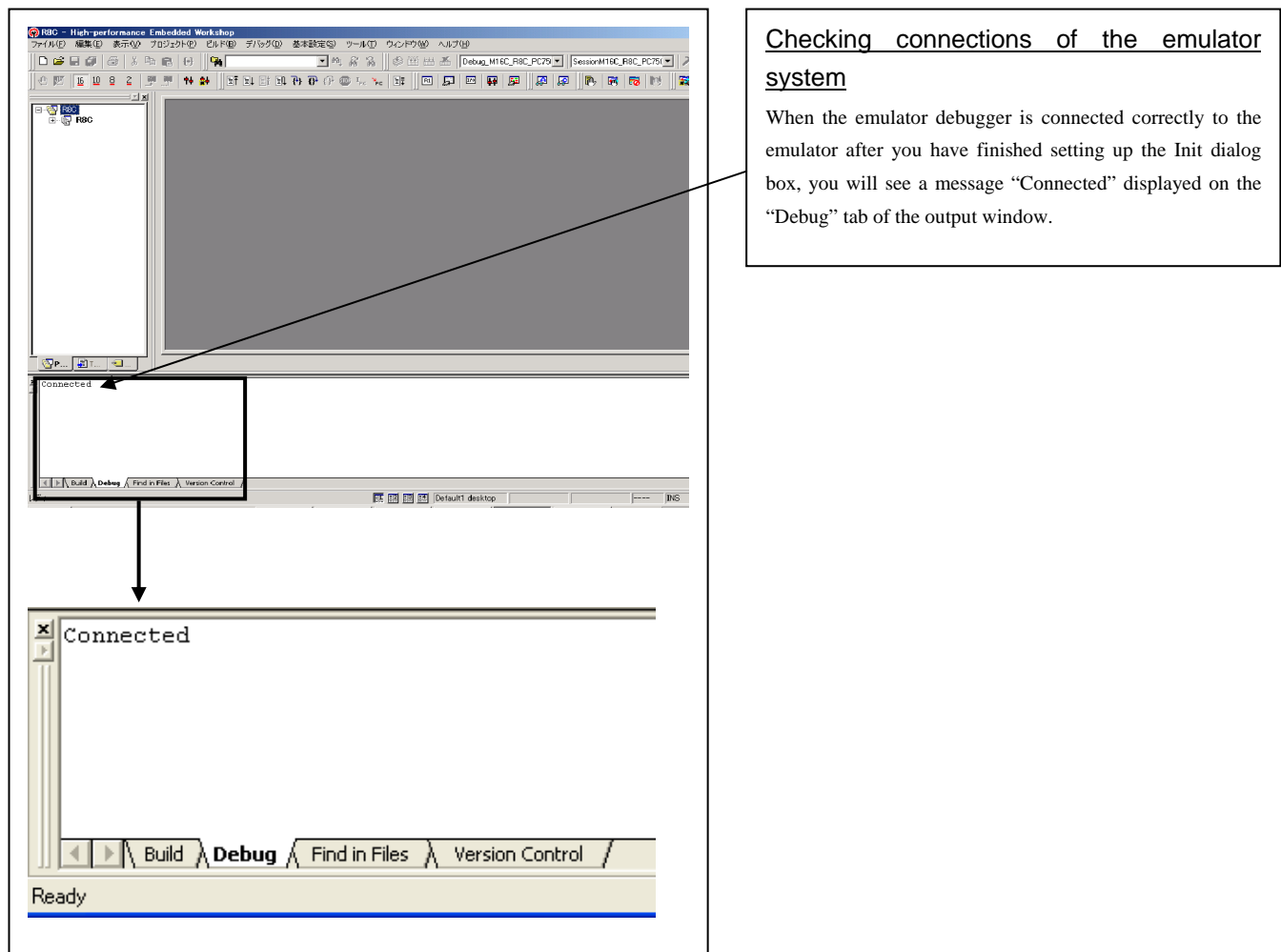

3.3 Setup Before Debugging

(1) Memory Map setting when power is turned on

The initial MAP information of this emulator is as follows.

0000h--3FFFh: External

4000h--FFFFh: Internal

Alter the memory MAP information according to the memory space of the target MCU used. To change the memory MAP information, use the Map command of the script window.

Area	Setting	Description
SFR	External	Uses the internal resources of the emulator MCU.
Internal RAM *1		
Internal ROM	Internal	Enables the internal resources of the emulator.
External ROM	External *2	Memory expansion mode and microprocessor mode only.

*1 If the internal RAM of the target MCU is larger than that of the emulator MCU, the internal resources of the emulator can be enabled by setting the insufficient RAM area for Internal. Always be sure set the internal resources of the emulator MCU (SFR/RAM areas) for External.

*2 If the user system has no memory reserved for it in its initial debugging state, etc., the internal resources of the emulator can be enabled by setting that area for Internal

(2) Example memory MAP setting

If the ROM size of the target microcomputer is 60 KB (38000 Series MCU), the area at addresses from 1080h to 3FFFh which has been set to External when the emulator is powered on must be changed to Internal.

1. Example memory MAP setting

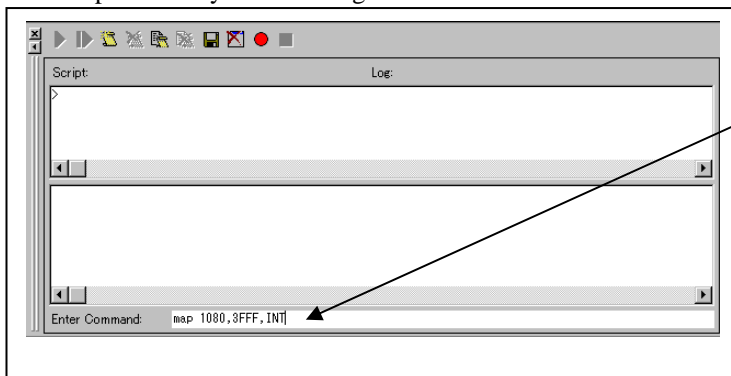

Example memory MAP setting
 Select Script from the View menu.
 In the Enter Command field, input “map 1080,3FFF,INT” and press the Enter key.

3.4 Program Execution

(1) Downloading the program

2. Downloading form the work space window

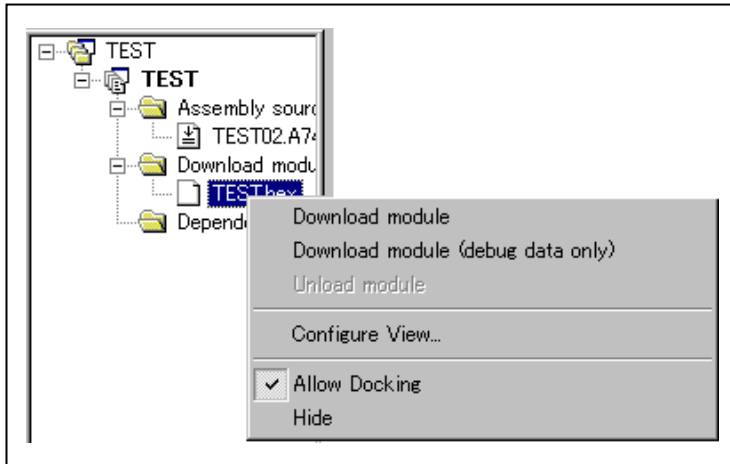

Downloading the program

Download the object program you want to debug.

Select Download from “xxx.hex” of “Download module”.

Or you can select “Download” from the “Debug” menu for the same effect.

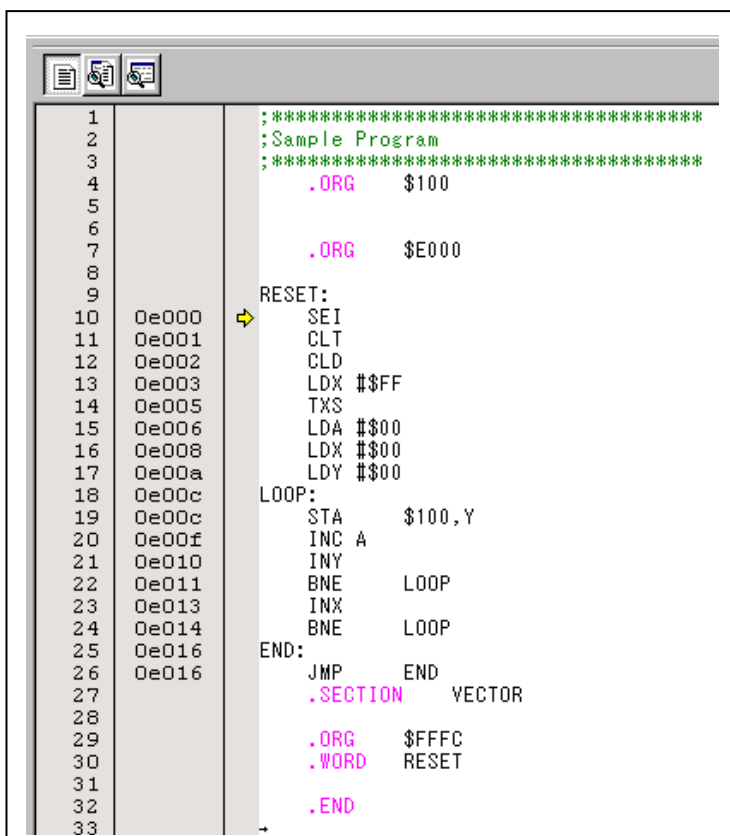

Showing the source program

Double-click on the Assembly source file “xxx.A74.” The editor (source) window will appear, showing the content of the “xxx.A74” file.

(2) Program execution

1. Resetting the user program

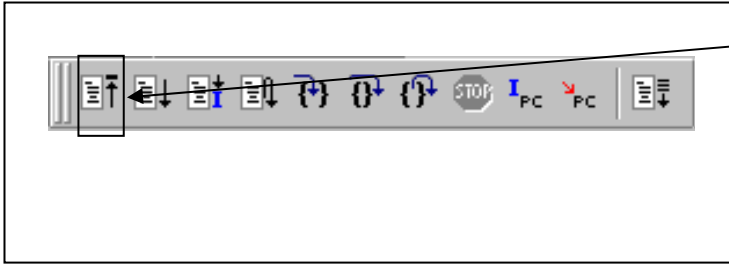
**CPU reset**

Resets the user program.

Or you can select "CPU Reset" from "Debug" menu for the same effect.

2. Executing the user program (Go)

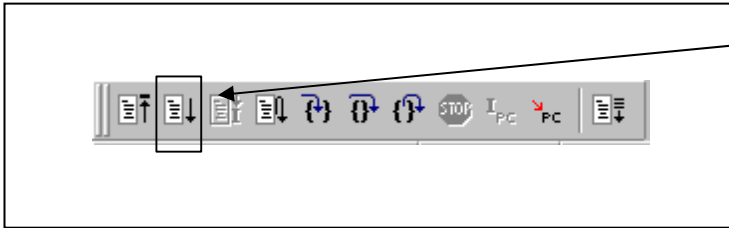
**Go**

Runs the program beginning with the current PC position.

Or you can select "Go" from "Debug" menu for the same effect.

3. Executing the user program (Go Free)

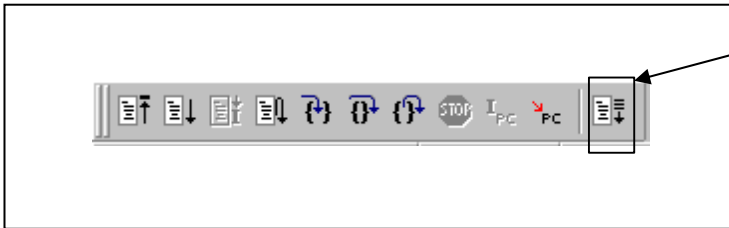
**Go Free**

Runs the program beginning with the current PC position. The software and hardware breaks set in it are ignored.

4. Executing the user program (Reset Go)

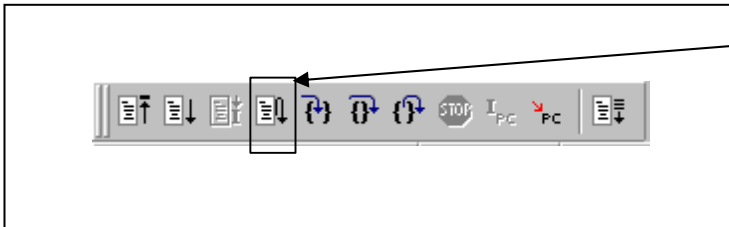
**Reset Go**

Runs the user program after reset the emulator MCU.

Or you can select "Reset Go" from "Debug" menu for the same effect.

5. Step execution of the user program

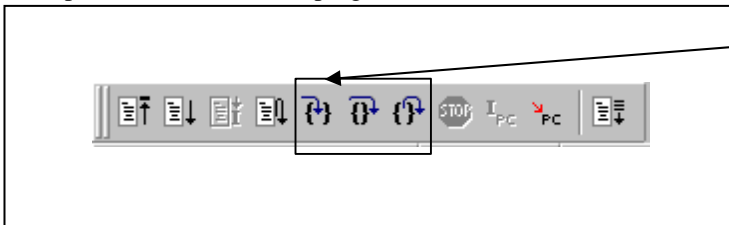
**Step In**

Single-steps the program executing each statement (including those in functions).

Step Over

Single-steps the program executing each function call as one step.

Step Out

Exists a function and stops at a statement in the program next to the one that called the function.

Or you can select "Step In" or other corresponding commands from "Debug" menu for the same effect.

6. Stopping the user program

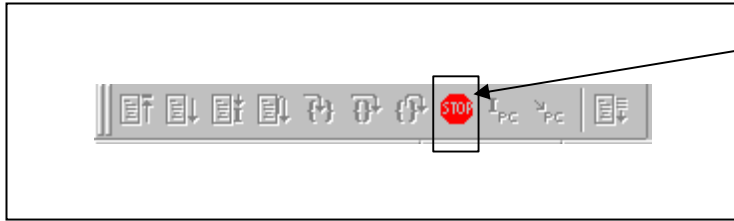

STOP
 Stops the user program.
 Or you can select "Stop" from "Debug" menu for the same effect.

7. Editor (Source) window after you have stopped the user program

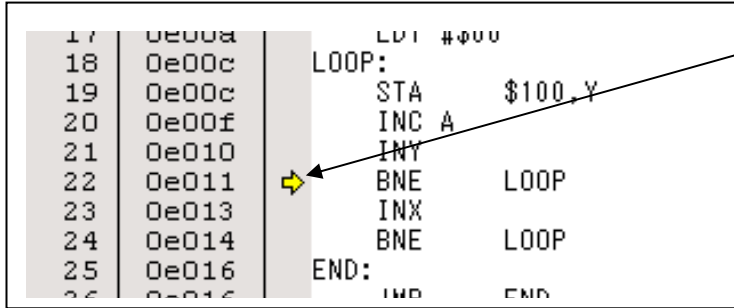

Editor (Source) window
 The position at which the user program has stopped is marked by a yellow arrow.

(3) Setting software breakpoints

1. Screen after breakpoint setup

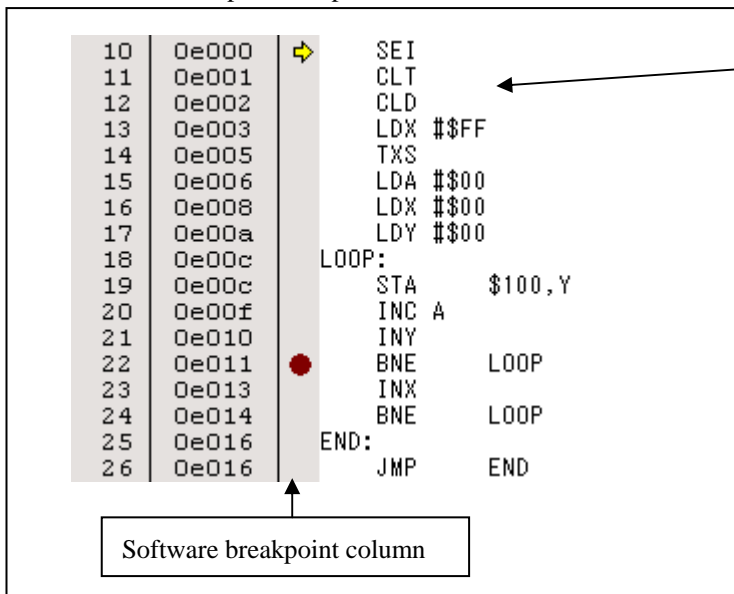

Screen after software breakpoint setup

- Software breakpoint (●)

A software breakpoint can be set or cleared by double-clicking the software breakpoint column. This is rewritten to a break instruction, therefore, program execution starts.

Or you can select "Break" -> "S/W breakpoint" from "S/W breakpoint" button of the tool menu or "Display" menu for the same effect.

Software breakpoint column

(4) Executing up to the cursor position

1. Setup procedure for running the program up to the cursor position

8		
9		RESET:
10	0e000	SEI
11	0e001	CLT
12	0e002	CLD
13	0e003	LDX #\$FF
14	0e005	TXS
15	0e006	LDA #\$00
16	0e008	LDX #\$00
17	0e00a	LDY #\$00
18	0e00c	LOOP:
19	0e00c	STA \$100,Y
20	0e00f	INC A
21	0e010	INY
22	0e011	BNE LOOP
23	0e013	INX
24	0e014	BNE LOOP
25	0e016	END:
26	0e016	JMP END

Setup procedure for running the program up to the cursor position

(1) Click the line in the editor (source) window that you want to be executed.

(2) Click the execution button to the cursor position.

Or you can select "Go to Cursor" from "Debug" menu for the same effect.

2. After the execution has finished

9		RESET:
10	0e000	SEI
11	0e001	CLT
12	0e002	CLD
13	0e003	LDX #\$FF
14	0e005	TXS
15	0e006	LDA #\$00
16	0e008	LDX #\$00
17	0e00a	LDY #\$00
18	0e00c	LOOP:
19	0e00c	STA \$100,Y
20	0e00f	INC A
21	0e010	INY
22	0e011	BNE LOOP
23	0e013	INX
24	0e014	BNE LOOP
25	0e016	END:
26	0e016	JMP END

3.5 Hardware Breakpoint Setting Window

(1) Breakpoint setup dialog box

1. Opening the hardware breakpoint setup dialog box

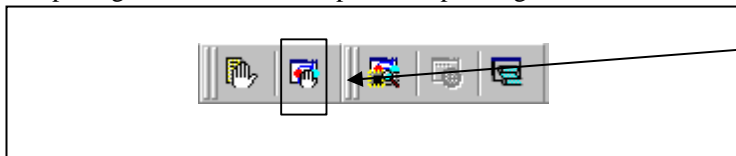

Hardware Break Point
 Clicking this button opens the hardware breakpoint setup dialog box.
 Or you can select "Break" -> "H/W Break" from "Display" menu for the same effect.

2. Hardware Break Point Setting Window in initial state

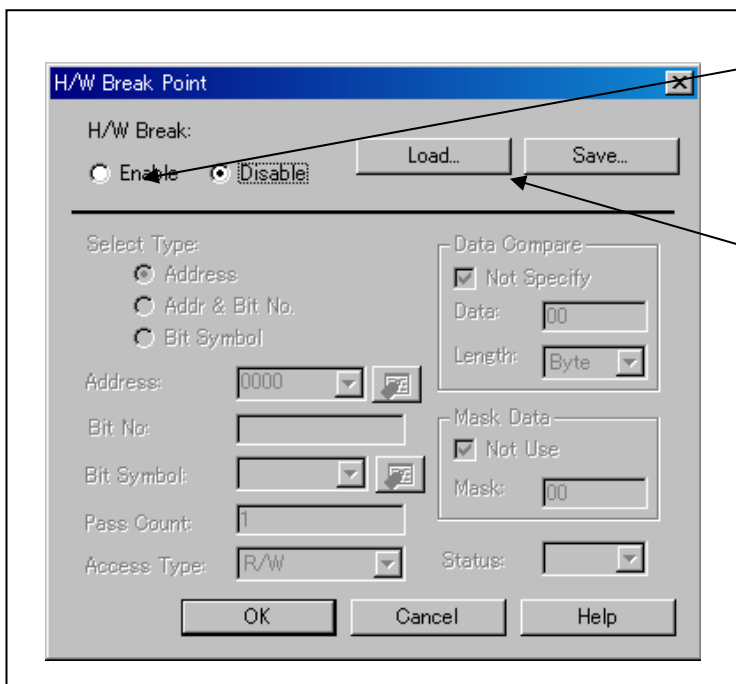

Hardware breakpoint Setting Window in initial state
 Select the "Enable H/W Break" check box, and this break function will be enabled, allowing you to set hardware breakpoints.
 The breakpoint information can be saved to a file.
 The saved breakpoint information can be loaded.

(2) Break event type selection

1. When Address is selected

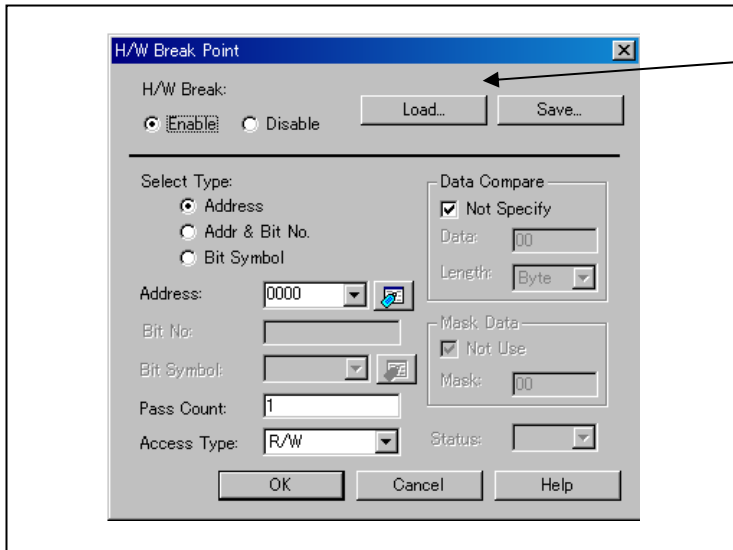

Event type (Address)
 You can set a specified address, pass count, access condition, or data comparison. When you finished setting, click OK.
 Address: Specify a break address.
 Pass count: Specify a pass count.
 Access condition: Specify instruction fetch (Fetch) or memory access (Write, Read, or R/W).
 Data comparison: When you specified memory access for the access condition, you can specify a comparison condition. For example, you can specify that a break should occur when the data read from or written to the address breakpoint has a specific value. Furthermore, you can specify valid or invalid bits for that specific value.

2. When Addr & Bit No. are selected

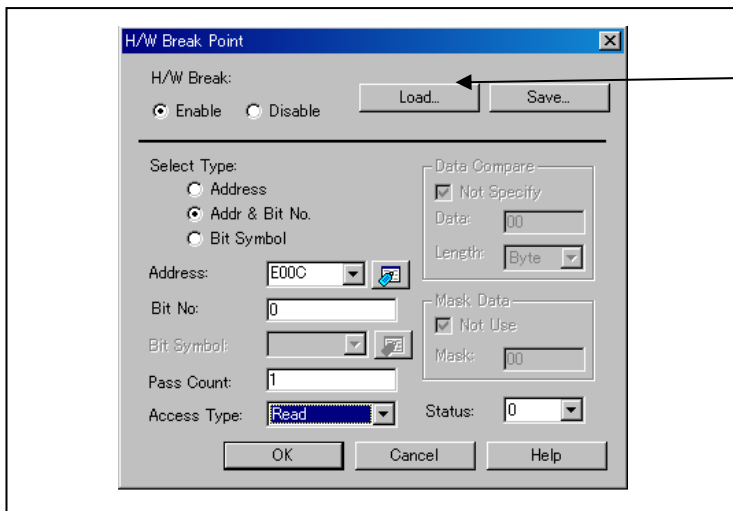

Event type (Addr & Bit No.)
 You can set a specified address, pass count, access condition, or data comparison. When you finished setting, click OK.
 Address: Specify a break address.
 Bit: Specify a bit.
 Pass count: Specify a pass count.
 Access condition: Specify a memory access (Write, Read, or R/W).
 Data comparison: You can specify valid or invalid bits for that specific value.

3. When Bit Symbol is selected

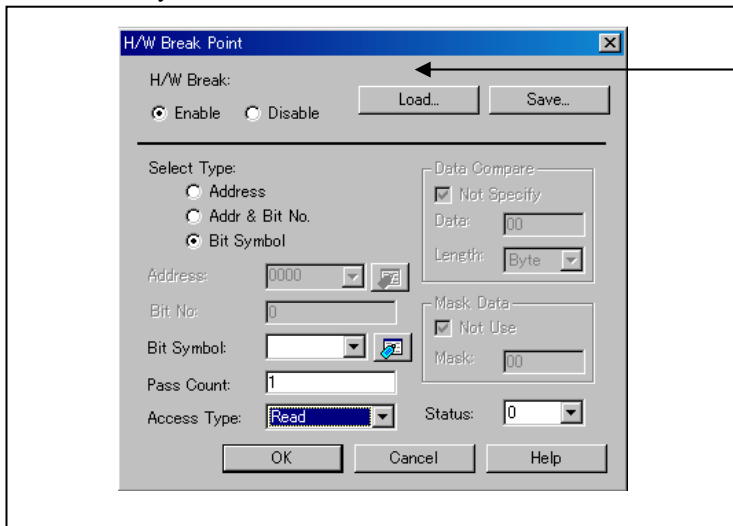

Event type (Bit Symbol)
 You can set a specified address, pass count, access condition, or data comparison. When you finished setting, click OK.
 Bit symbol: Specify a bit symbol.
 Pass count: Specify a pass count.
 Access condition: Specify a memory access (Write, Read, or R/W).
 Data comparison: You can specify valid or invalid bits for that specific value.

3.6 Trace Window

(1) Trace window

1. Opening the trace window

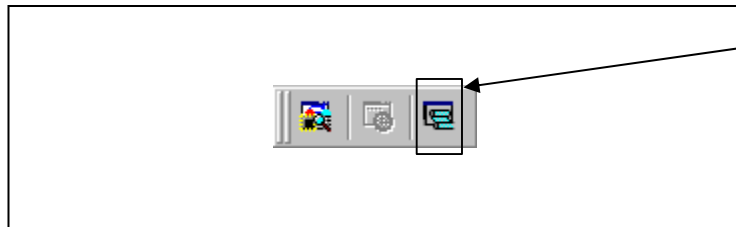

Trace window

Clicking this button opens the trace window.

Or you can select "Trace" from "Trace" of "Display" menu for the same effect.

2. Trace window

Cycle	Label	Address	Data	Sync	Read	Write	DataAccess
	sample.A74, 10:			SEI			
	E000	RESET		SEI			
-00032	RESET	E000	78	1	0	1	
-00031		E001	12	0	0	1	
	sample.A74, 11:			CLT			
	E001			CLT			
-00030		E001	12	1	0	1	
-00029		E002	D8	0	0	1	
	sample.A74, 12:			CLD			
	E002			CLD			
-00028		E002	D8	1	0	1	
-00027		E003	A2	0	0	1	
	sample.A74, 13:			LDX #FFH			
	E003			LDX #FFH			
-00026		E003	A2	1	0	1	
-00025		E004	FF	0	0	1	
	sample.A74, 14:			TXS			
	E005			TXS			
-00024		E005	9A	1	0	1	
-00023		E006	A9	0	0	1	

Trace window

The trace window is used to show the results of real-time trace measurements. It has the following four display modes:

- Bus mode 

Bus information per cycle can be inspected. The contents are displayed in order of execution paths.
- Disassemble mode 

The execution paths of the executed instructions can be inspected. The contents are displayed in order of execution paths.
- Source mode 

The execution paths of the source program can be inspected. Operating buttons of the tool bar can reference the execution paths.
- Data access mode 

Data read/write cycles can be inspected. In addition to the data access information, the window can display the source line information in combination with it.

The trace window shows the measurement result when a real-time trace measurement has finished. The trace window remains blank until the real-time trace measurement in progress finishes.

3. Example of the trace window display

Bus display (BUS)

Cycle	Label	Address	Data	Sync	Read	Write
-00032	RESET	E000	78	1	0	1
-00031		E001	12	0	0	1
-00030		E001	12	1	0	1
-00029		E002	D8	0	0	1
-00028		E002	D8	1	0	1
-00027		E003	A2	0	0	1
-00026		E003	A2	1	0	1
-00025		E004	FF	0	0	1
-00024		E005	9A	1	0	1
-00023		E006	A9	0	0	1
-00022		E006	A9	1	0	1
-00021		E007	00	0	0	1
-00020		E008	A2	1	0	1
-00019		E009	00	0	0	1

Disassemble display (DIS)

Cycle	Address	Obj-code	Label	Mnemonic
-00032	E000	78	RESET	SEI
-00030	E001	12		CLT
-00028	E002	D8		CLD
-00026	E003	A2FF		LDX #FFH
-00024	E005	9A		TXS
-00022	E006	A900		LDA #00H
-00020	E008	A200		LDX #00H
-00018	E00A	A000		LDY #00H
-00016	E00C	990001	LOOP	STA 0100H, Y
-00010	E00F	3A		INC A
-00008	E010	C8		INY
+++				INTERRUPT ---> VECTOR ADDRESS in \$FFDC

Source display (SRC)

Line	Address	Now	Source
00010	E000	>>	SEI
00011	E001	-	CLT
00012	E002	-	CLD
00013	E003	-	LDX #FFH
00014	E005	-	TXS
00015	E006	-	LDA #00
00016	E008	-	LDX #00
00017	E00A	-	LDY #00
00018	E00C	-	LOOP: STA \$100, Y
00019	E00C	-	
00020	E00F	-	INC A
00021	E010	-	INY
00022	E011	-	BNE LOOP

Data access display (DATA)

Cycle	Label	DataAccess	h" m' s: ms. us
-00011		(0100 00 W)	
-00005		(E012 F9 R)	
-00004		(00FF E0 W)	
-00003		(00FE 13 W)	
-00002		(00FD 14 W)	
-00001		(FFDC 90 R)	
00000		(FFDD 40 R)	

Explanation of the trace window (bus display)

The following explains the displayed contents, from left to right.

- Address
Shows the status of the address bus.
- Data
Shows the status of the data bus.
- SYNC
Output during instruction opcode fetch, this signal assumes the value 1 when opcode is fetched. If the displayed Sync value is enclosed in parentheses as in (1), it means a dummy Sync, in which case the instruction in that line actually is not executed. If not accessed, the value is displayed as "-".
- Read
Indicates the data bus state. This signal determines the direction of the data bus. When in a Read state, it indicates the value 0.
- Write
Indicates the data bus state. This signal determines the direction of the data bus. When in a Write state, it indicates the value 0.

(2) Suspending and resuming trace measurement

1. Suspending trace measurement

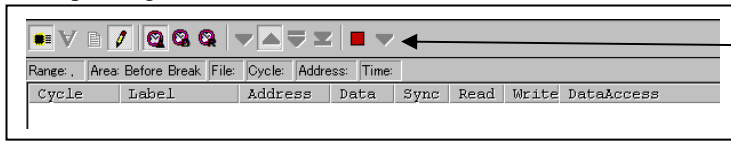

Stop
Click this toolbar button to suspend the trace measurement in progress.

2. Resuming trace measurement

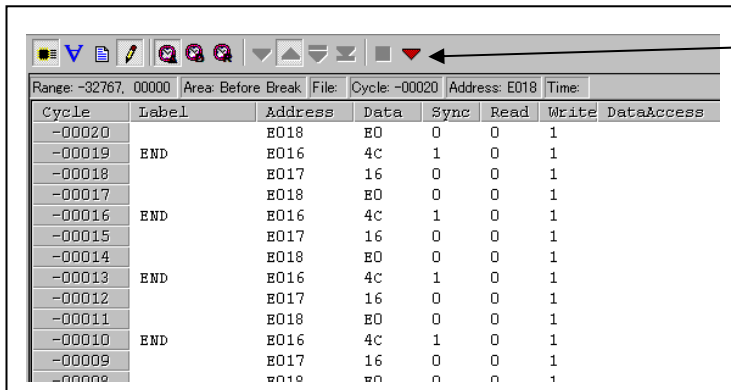

Re-Start
Click this toolbar button to resume the trace measurement in progress.

(3) Trace point setup dialog box

1. Opening the trace point setup dialog box



Trace Point
Clicking this toolbar button opens the trace point setting window.
Or you can select "Trace point" from "Trace" of "Display" menu for the same effect.

2. Trace Point Setting Window in initial state

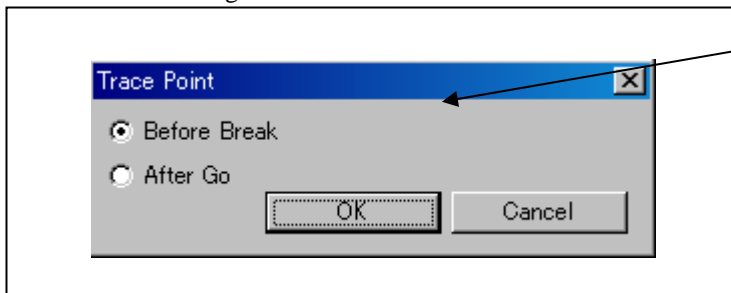

Trace Point Setting Window in initial state
You can specify following two trace ranges for the trace event.

- Before Break
32K cycles of instruction execution before the user program stopped is recorded.
- After Go
32K cycles of instruction execution after a trace began is recorded.

3.7 RAM Monitor Window

This function makes it possible to make reference to the changes in memory contents without impairing the real-time performance for target program execution. The compact emulator system is provided with the 1K-byte RAM monitoring area (which cannot be divided into several area).

(1) RAM monitor window

1. Opening the RAM monitor window

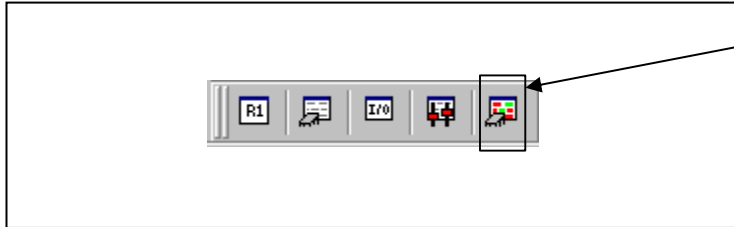

RAM monitor
 Clicking this button opens the RAM monitor window.
 Or you can select "RAM monitor" from "CPU" of "Display" menu for the same effect.

2.

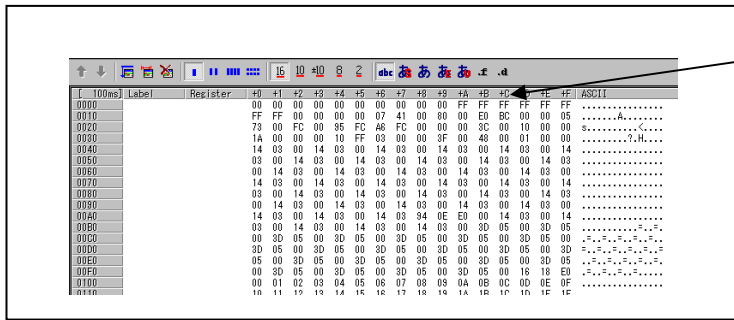

RAM monitor window
 This window shows changes of memory contents while the user program is executed. This is accomplished by using the real-time RAM monitor function, and the memory contents corresponding to the RAM monitor area are displayed in dump form. The memory contents displayed here are updated at given intervals (by default, every 100 ms) during user program execution.

(2) RAM monitor area setting window

1. Opening RAM monitor area setting window



RAM monitor area setting
 Clicking this toolbar button opens the RAM monitor area setting window.

2. RAM monitor area setting dialog box

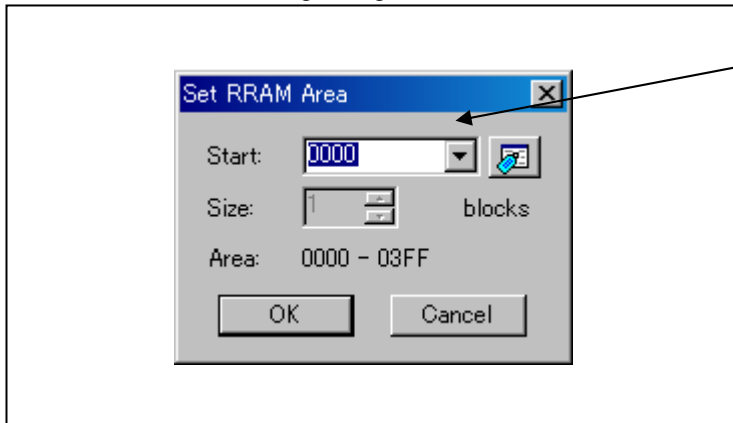

Specifying the start address
 You can set the start address of the RAM area to be monitored.
 You can set the address by 64 bytes.

3. RAM monitor display area

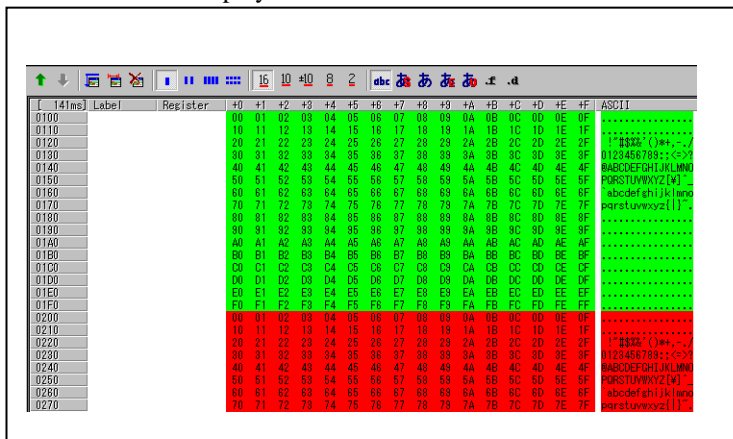

RAM monitor display area
 The background colors of the data display and the code display sections change with the access attribute as described below.

- Green Addresses accessed for read
- Red Addresses accessed for write
- White Addresses not accessed

4. Hardware Specifications

This chapter describes specifications of this product.

4.1 Target MCU Specifications

Table 4.1 lists the specifications of target MCUs which can be debugged with this product.

Table 4.1 Specifications of target MCUs for the M38000T2-CPE

Applicable MCUs	740 Family MCUs which have emulator MCUs*	
Usable mode	Single-chip mode Memory expansion mode Microprocessor mode	
Applicable power supply	When the emulator MCU is RSS or RFS type.	2.7 to 5.0 V (within the MCU's specified range)
	When the emulator MCU is RLSS or RLFS type.	1.8 to 5.0 V (within the MCU's specified range)
Emulation memory	64 KB (can be mapped by 64 bytes)	
Clock supply	Only the clock on the user system can be used.	

* Applicable MCUs are occasionally updated. For more information on applicable MCUs, please visit the Renesas Tool Homepage at <http://www.renesas.com/tools>

4.2 Applicable MCU

Table 4.2 lists the target MCUs to be debugged with this product.

Table 4.2 List of the applicable MCUs

Series	Group	Emulator MCU	Emulator MCU Type selection	MCU file	Temporary target board	Operating condition
38000	3803 3803H 3803L	M38049RLSS	RLSS/RLFS	M38000.MCU	M38007T-ADS	Refer to 4.2.1 (1)
	3804 3804L	M38049RLSS	RLSS/RLFS		M38007T-ADS	Refer to 4.2.1 (1)
	3822 3822M 3822H 3822A	M38227RFS	RSS/RFS		M38067T-ADF	Refer to 4.2.1 (2)
	3823	M3823AT-RLFS	RLSS/RLFS		M38067T-ADF	Refer to 4.2.1 (3)
	3826	M38267RLFS	RLSS/RLFS		M38187T-ADF	Refer to 4.2.1 (4)
	3826A	M38267RLFS	RLSS/RLFS		M38187T-ADF	Refer to 4.2.1 (4)
		M37560RLFS	RLSS/RLFS	M37560.MCU	M38187T-ADF	Refer to 4.2.3 (9)
	3850A	M38507ARLSS	RLSS/RLFS	M38000.MCU	M38517T-ADS	Refer to 4.2.1 (5)
	3850 3850H 3851	M38517RSS	RSS/RFS		M38517T-ADS	Refer to 4.2.1 (6)
	3858	M38588RSS	RSS/RFS		M38517T-ADS	Refer to 4.2.1 (7)
	3882 3885	M38859RLFS	RLSS/RLFS		M38067T-ADF	Refer to 4.2.1 (8)
	3886	M38867RLFS M38867RFS	RLSS/RLFS		M38067T-ADF	Refer to 4.2.1 (9)
	38C1	M38C13RLFS	RLSS/RLFS		-	Refer to 4.2.1 (10)
	38C2 38C2A	M38C29RLFS	RLSS/RLFS		M38C29T-ADF	Refer to 4.2.1 (11)
	38C5	M38C59T-RLFS	RLSS/RLFS		-	Refer to 4.2.1 (12)
	38D2	M38D29T2-RLFS ^{*2}	RLSS/RLFS		-	Refer to 4.2.1 (13)
	38D5	M38D59T-RLFS	RLSS/RLFS		-	Refer to 4.2.1 (14)
	38C8	M38C89RLFS	RLSS/RLFS		M38C89T-ADF	Refer to 4.2.1 (15)
	38K0	M38K09RFS	RSS/RFS		M38K29T-ADF	Refer to 4.2.1 (16)
	38K2	M38K29RFS	RSS/RFS			Refer to 4.2.1 (17)
7200	M37150	M37150ERSS	RSS/RFS		M37150.MCU	-
	M37151	M37151ERSS	RSS/RFS	M37151.MCU	-	Refer to 4.2.2 (2)
	M37160	M37160ERSS	RSS/RFS	M37160.MCU	-	Refer to 4.2.2 (3)
	M37161	M37161ERSS	RSS/RFS	M37161.MCU	-	Refer to 4.2.2 (4)
	M37221	M37221ERASS	RSS/RFS	M37221.MCU	-	Refer to 4.2.2 (5)
	M37225	M37225ERSS	RSS/RFS	M37225.MCU	-	Refer to 4.2.2 (6)
	M37280	M37280ERSS	RSS/RFS	M37280.MCU	-	Refer to 4.2.2 (7)
	M37281	M37281ERSS	RSS/RFS	M37281.MCU	-	Refer to 4.2.2 (8)
740	7516	M37516RSS	RSS/RFS	M37516.MCU	-	Refer to 4.2.3 (1)
	7517	M37517RLSS	RLSS/RLFS	M37517.MCU	-	Refer to 4.2.3 (2)
	7534	M37534RSS	RSS/RFS	M37534.MCU	M37531T-ADS	Refer to 4.2.3 (3)
	7540	M37540RSS	RSS/RFS	M37540.MCU	M37531T-ADS	Refer to 4.2.3 (4)
	7542	M37542RSS	RSS/RFS	M37542.MCU	M37531T-ADS	Refer to 4.2.3 (5)
	7544	M37544RSS	RSS/RFS	M37544.MCU	M37531T-ADS	Refer to 4.2.3 (6)
	7545	M37545RLSS	RLSS/RLFS	M37545.MCU	M37531T-ADS	Refer to 4.2.3 (7)
	7546 7547	M37542RSS	RSS/RFS	M37542.MCU	M37531T-ADS	Refer to 4.2.3 (5)
	7548 7549	M37549T-RLSS	RLSS/RLFS	M38000.MCU	M37531T-ADS	Refer to 4.2.3 (8)
	7560	M37560RLFS	RLSS/RLFS	M37560.MCU	M38187T-ADF	Refer to 4.2.3 (9)

*1 Applicable MCUs are occasionally updated. For more information on applicable MCUs, please visit the Renesas Tool Homepage at <http://www.renesas.com/tools>

*2 The M38D29T2-RLFS is sold as a part of the set packages with a converter board (M38D29T2-RLFS-FP or M38D29T2-RLFS-HP) and cannot be purchased separately.

4.2.1 Operating Condition for the 38000 Series

(1) M38049RLSS

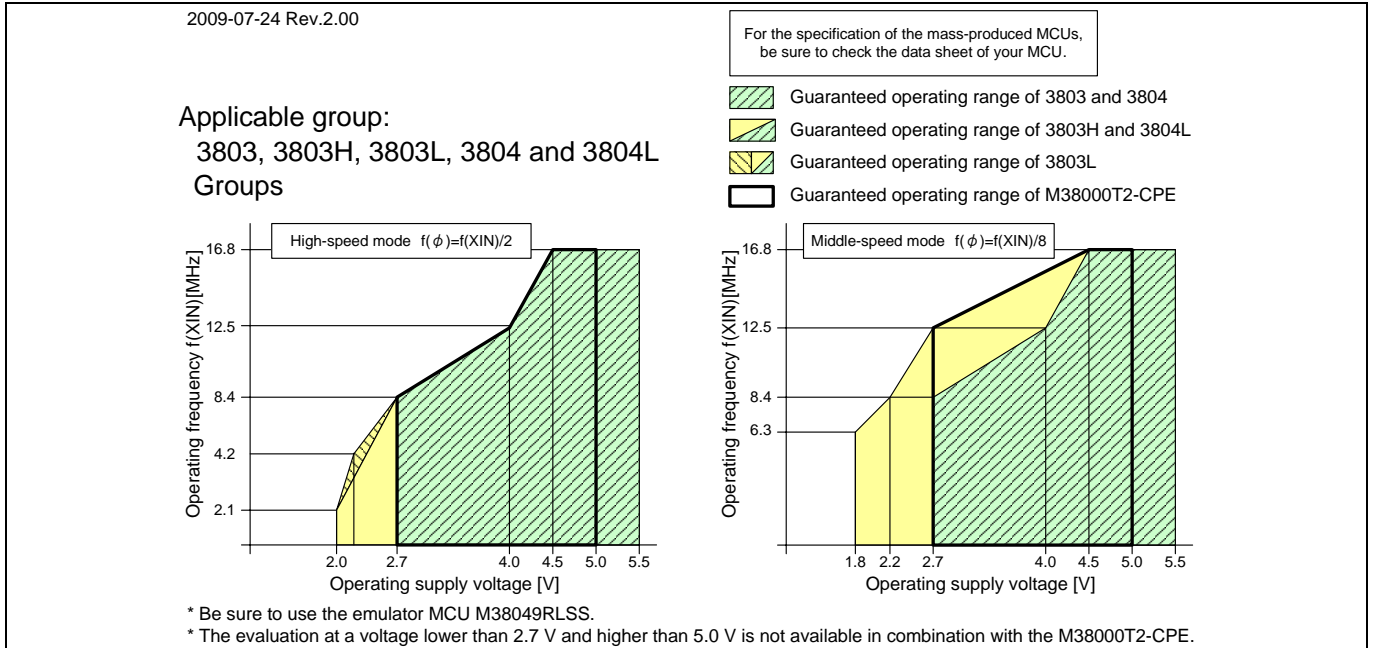

Figure 4.1 Operating conditions of the M38049RLSS

(2) M38227RFS

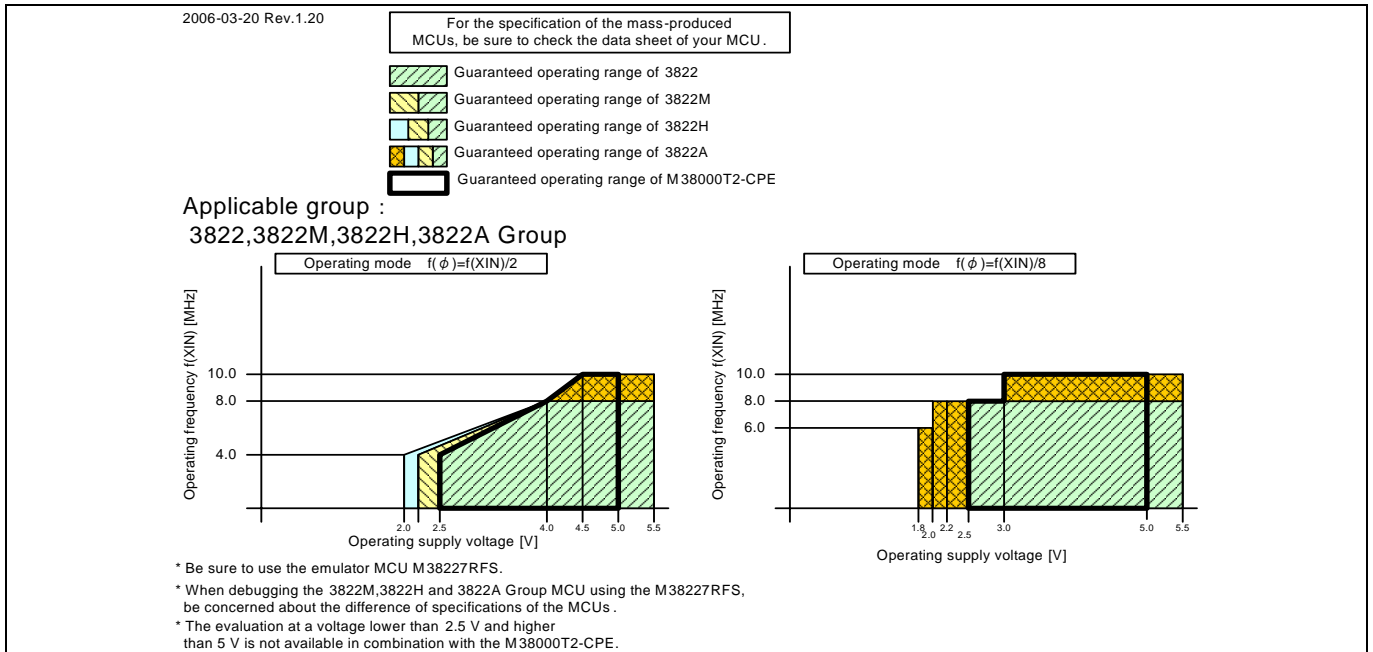

Figure 4.2 Operating conditions of the M38227RFS

IMPORTANT

Note on the M38227RFS:

- The M38227RFS is a standard type MCU. When debugging the 3822 Group M, H and A version MCUs using the M38227RFS, be concerned about the difference of specifications of the MCUs.

(3) M3823AT-RLFS

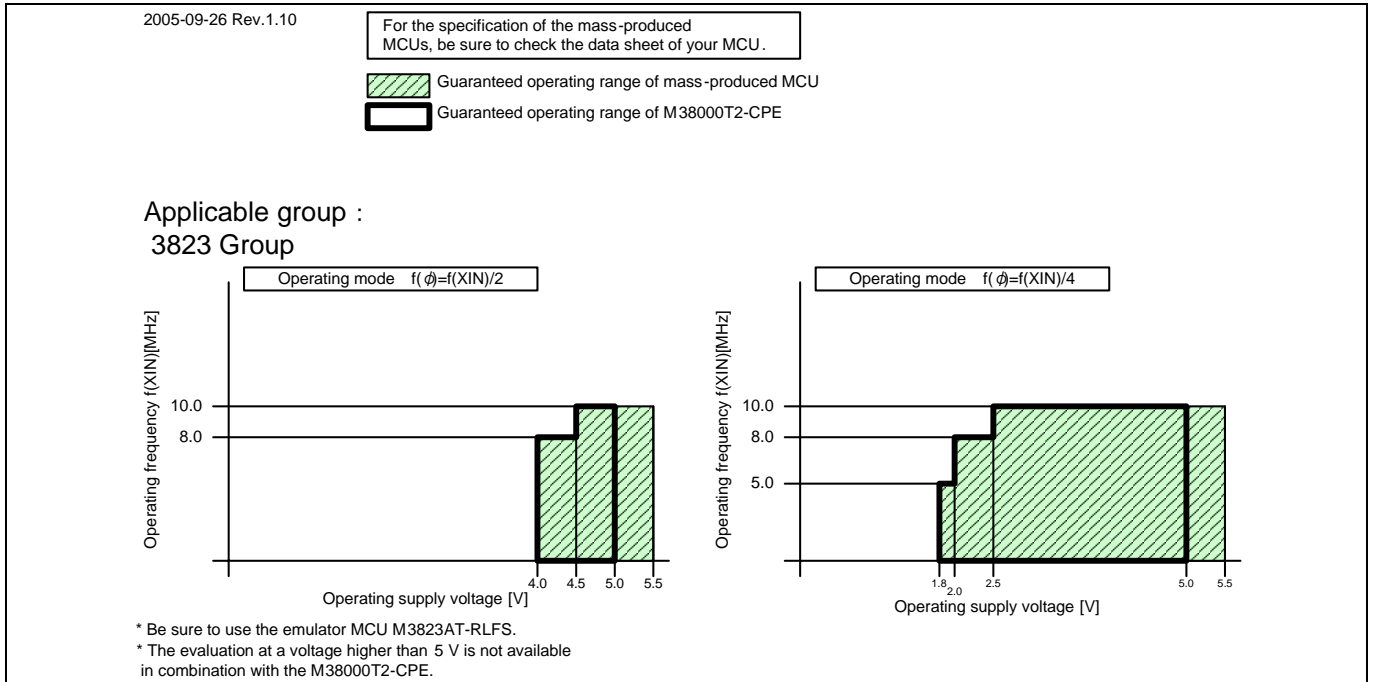

Figure 4.3 Operating conditions of the M3823AT-RLFS

(4) M38267RLFS

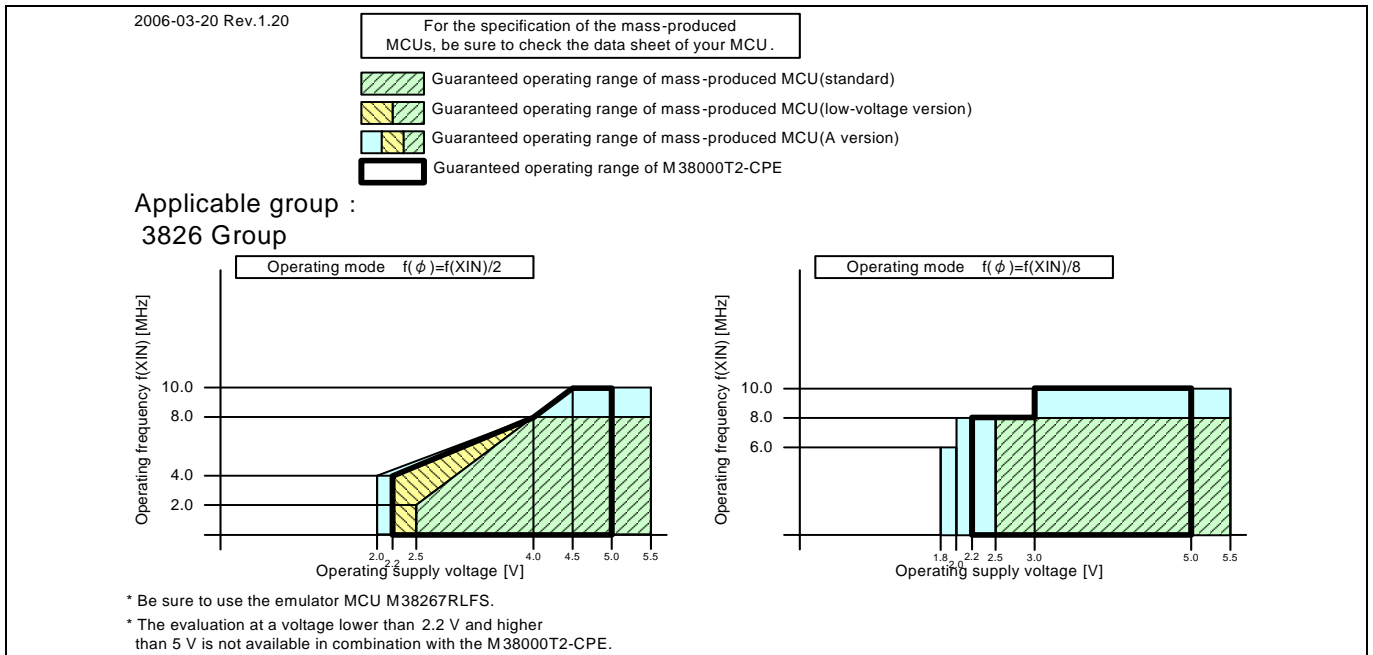

Figure 4.4 Operating conditions of the M38267RLFS

(5) M38507ARLSS

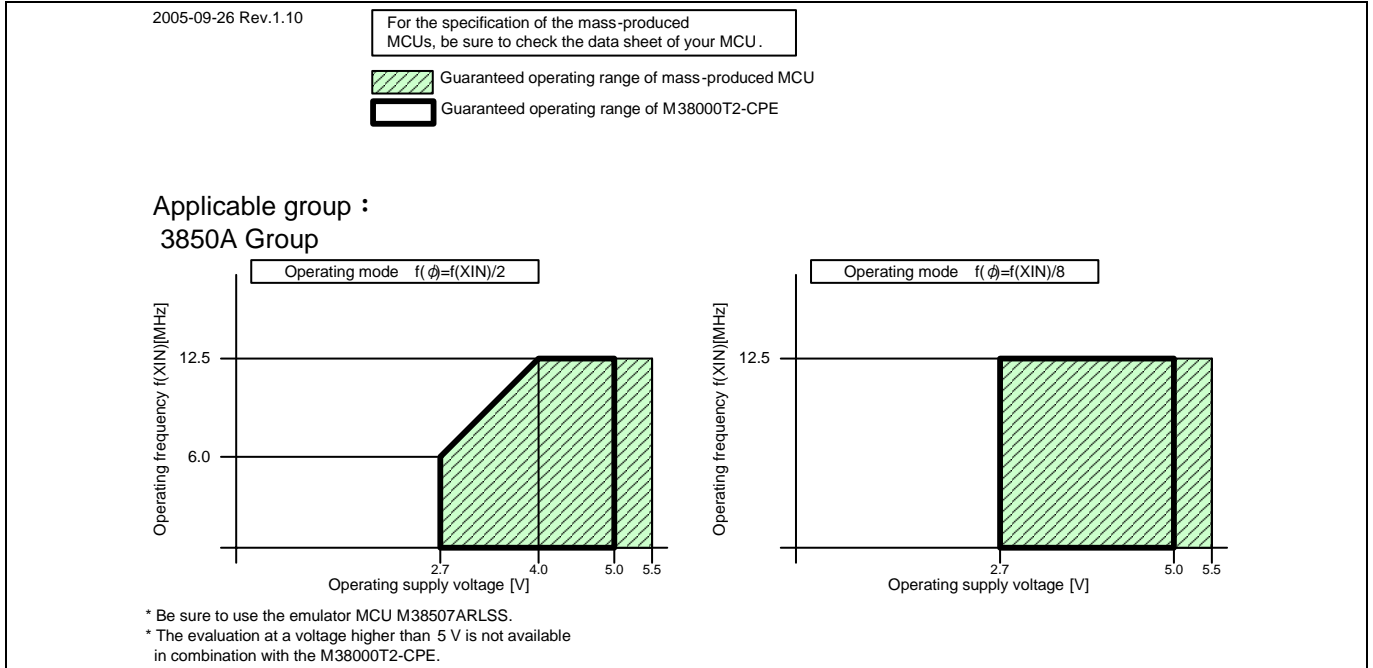

Figure 4.5 Operating conditions of the M38507ARLSS

(6) M38517RSS

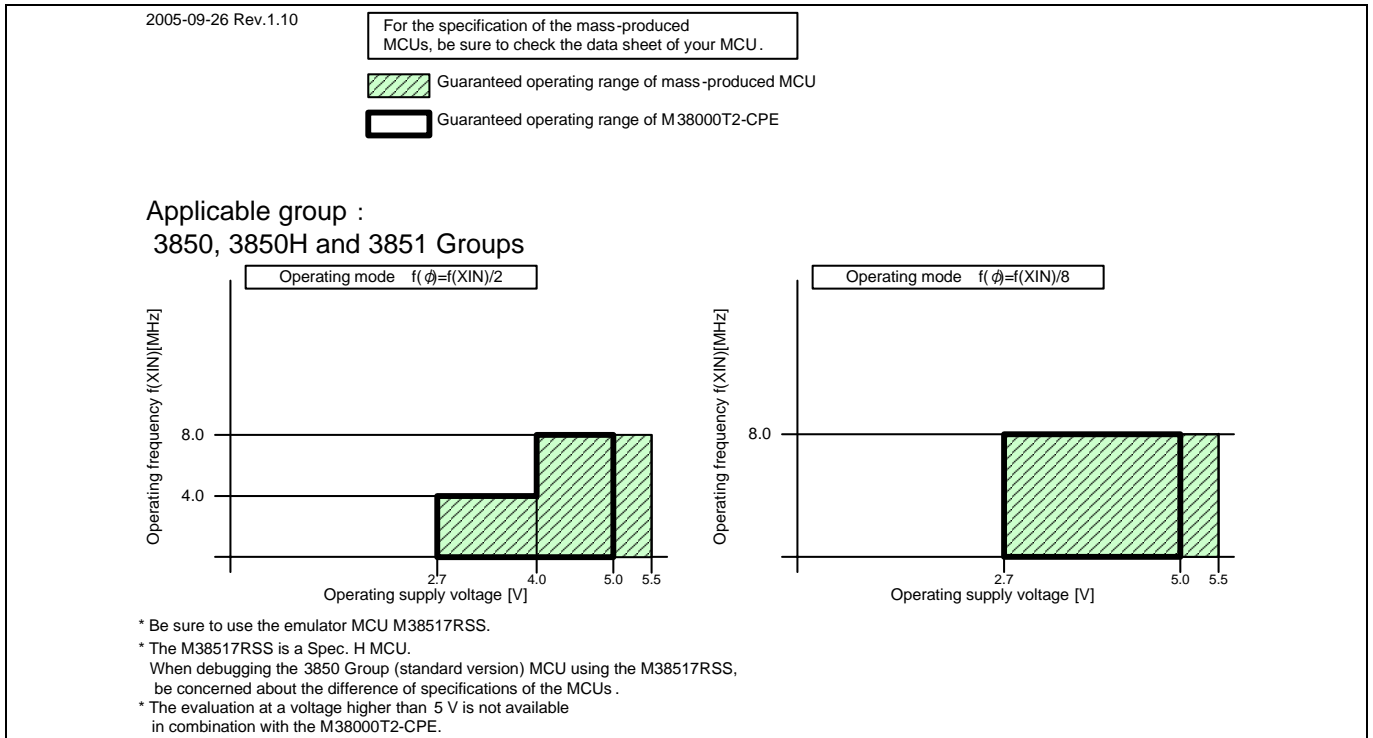

Figure 4.6 Operating conditions of the M38517RSS

IMPORTANT

Note on the M38517RSS:

- The M38517RSS is a Spec. H MCU. When debugging the standard version MCU using the M38517RSS, be concerned about the difference of specifications of the MCUs.

(7) M38588RSS

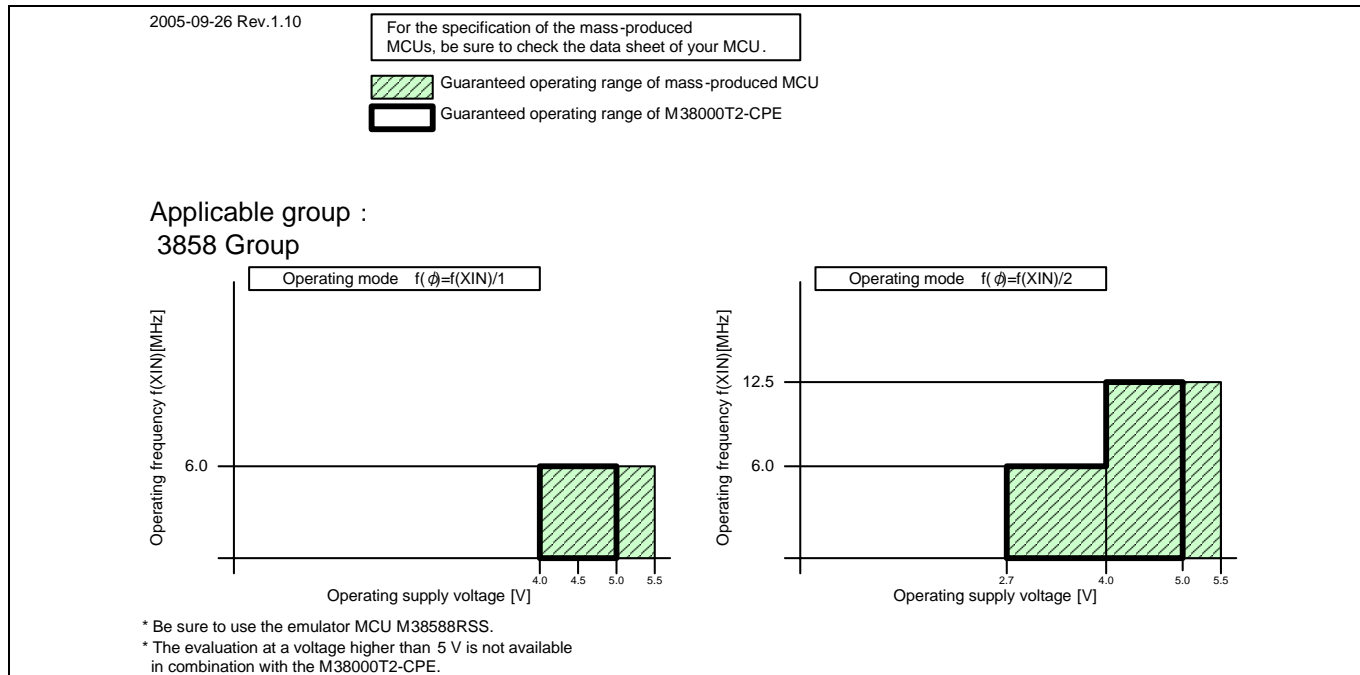

Figure 4.7 Operating conditions of the M38588RSS

(8) M38859RLFS

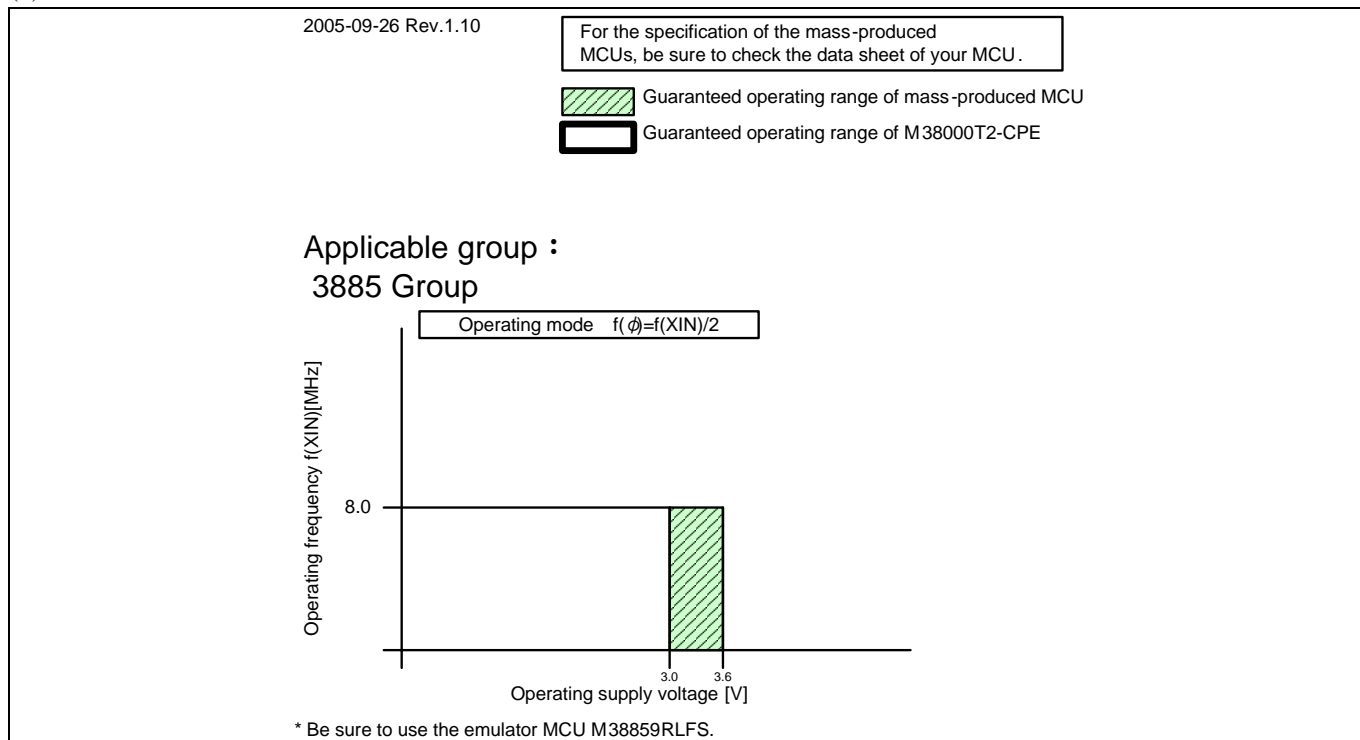

Figure 4.8 Operating conditions of the M38859RLFS

M38867RFS

(9) M38867RLFS

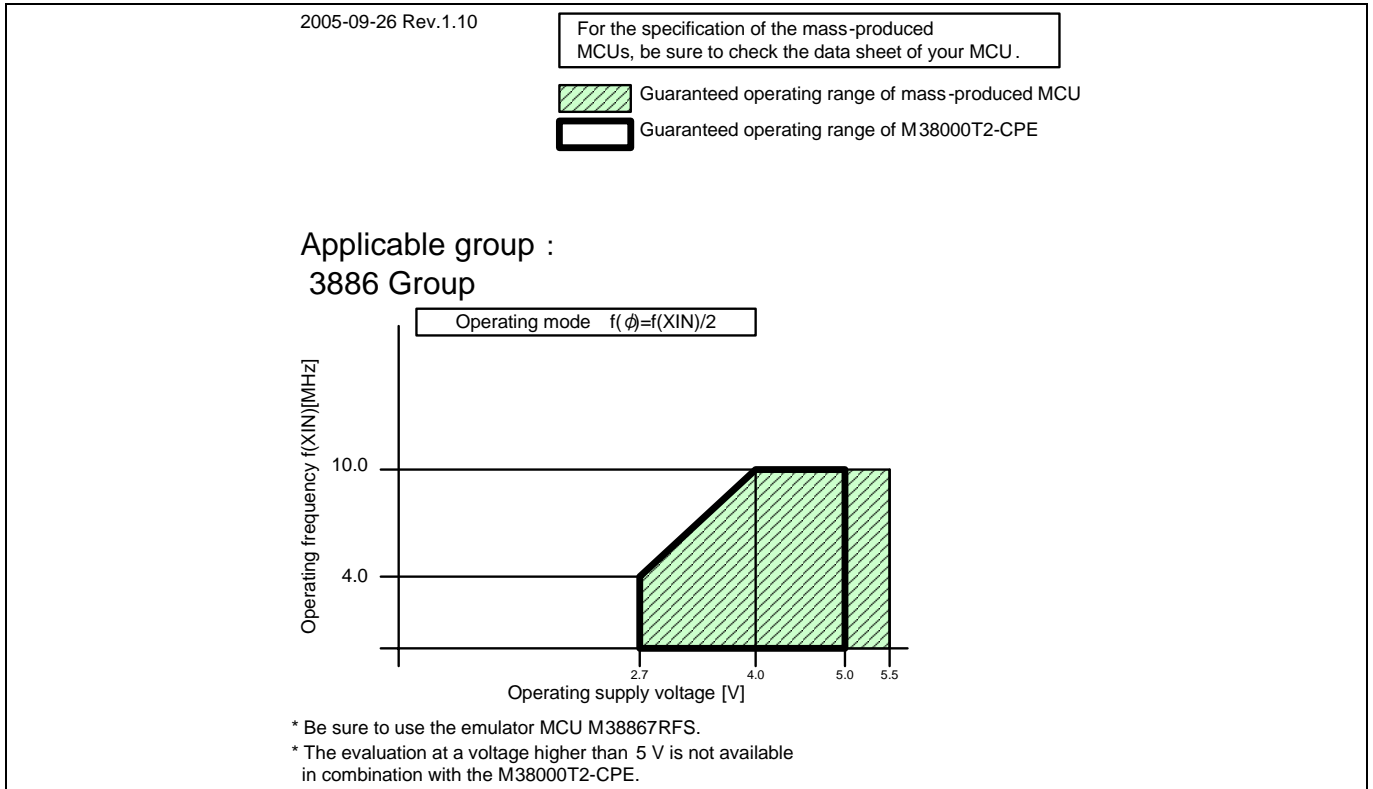

Figure 4.9 Operating conditions of the ~~M38867RLFS~~
M38867RFS

(10) M38C13RLFS

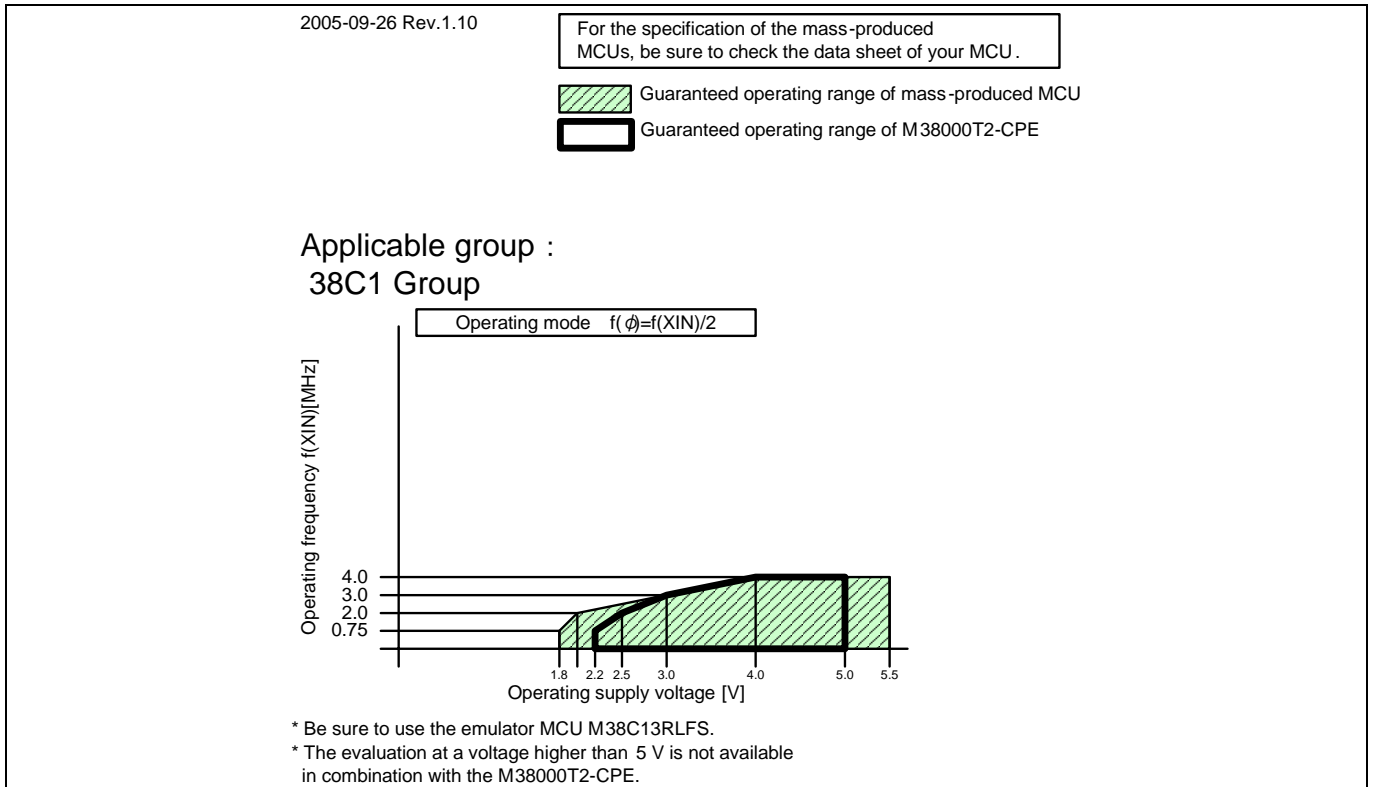

Figure 4.10 Operating conditions of the M38C13RLFS

(11) M38C29RLFS

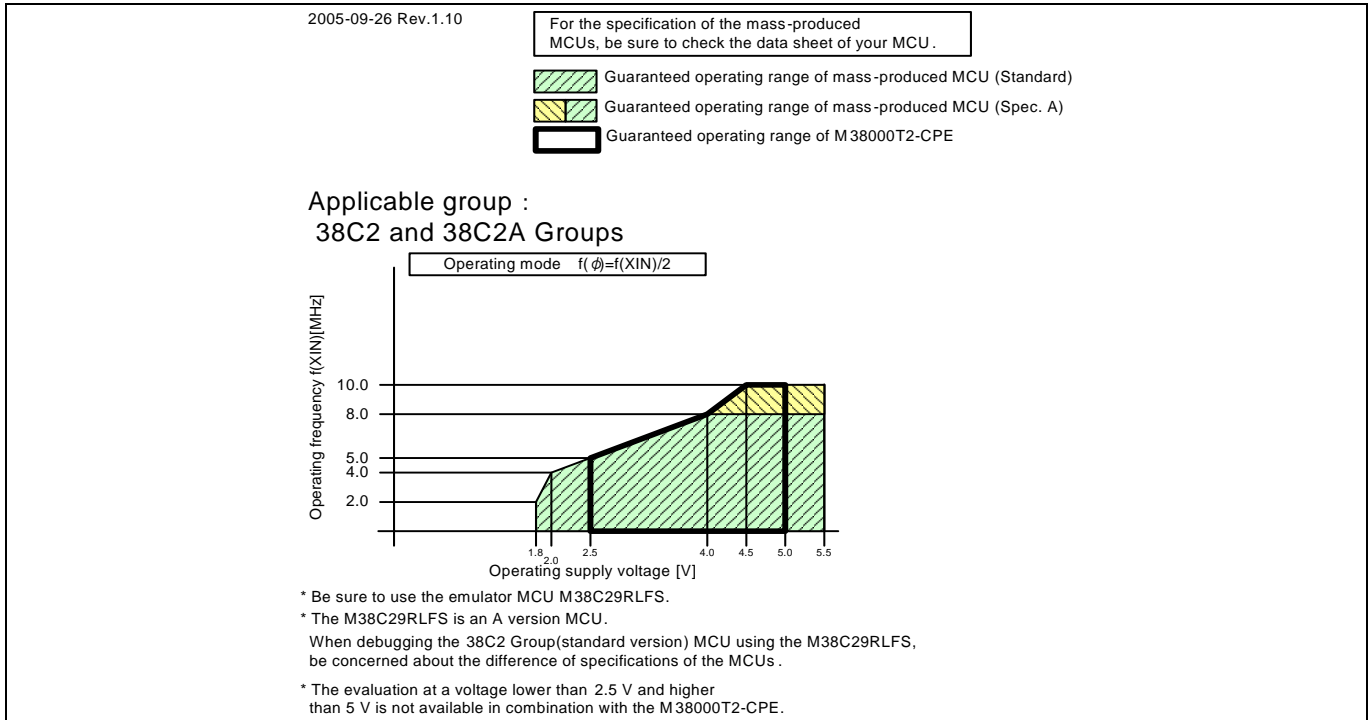

Figure 4.11 Operating conditions of the M38C29RLFS

IMPORTANT

Note on the M38C29RLFS:

- The M38C29RLFS is an A version MCU. When debugging the standard version MCU using the M38C29RLFS, be concerned about the difference of specifications of the MCUs.

(12) M38C59T-RLFS

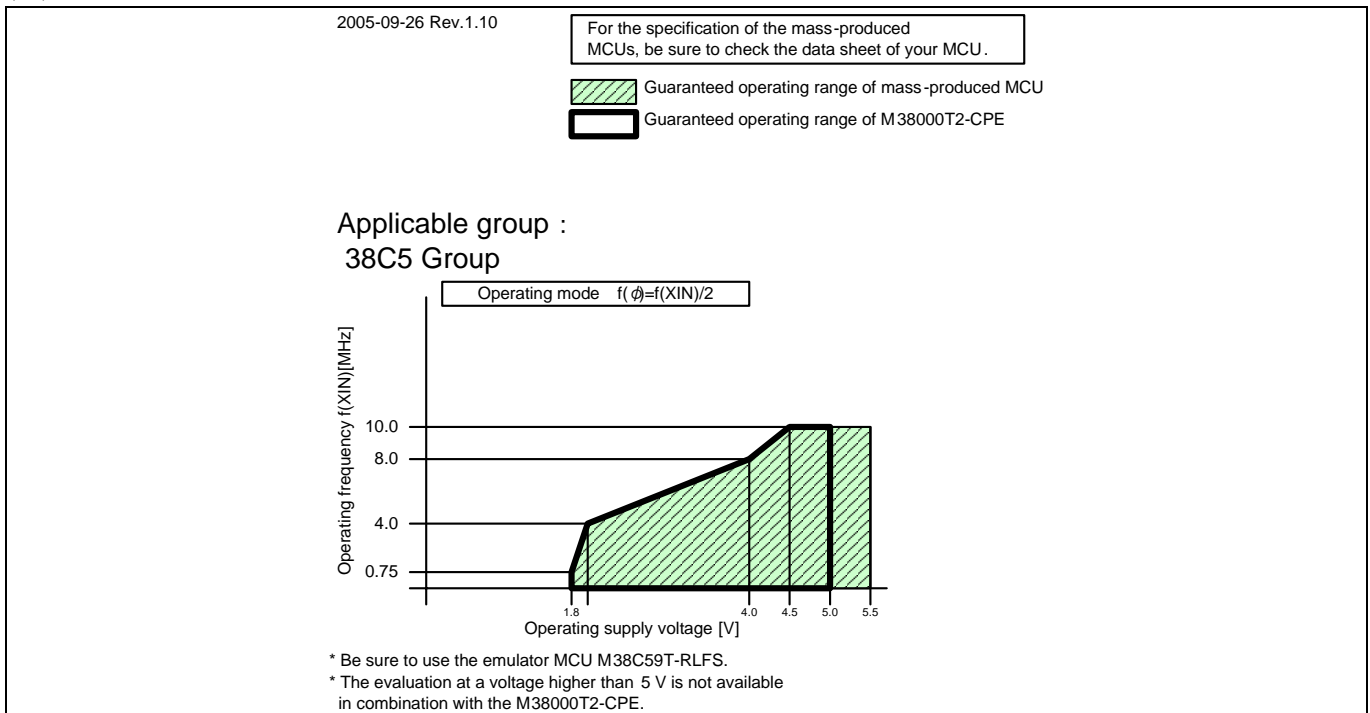

Figure 4.12 Operating conditions of the M38C59T-RLFS

(13) M38D29T2-RLFS

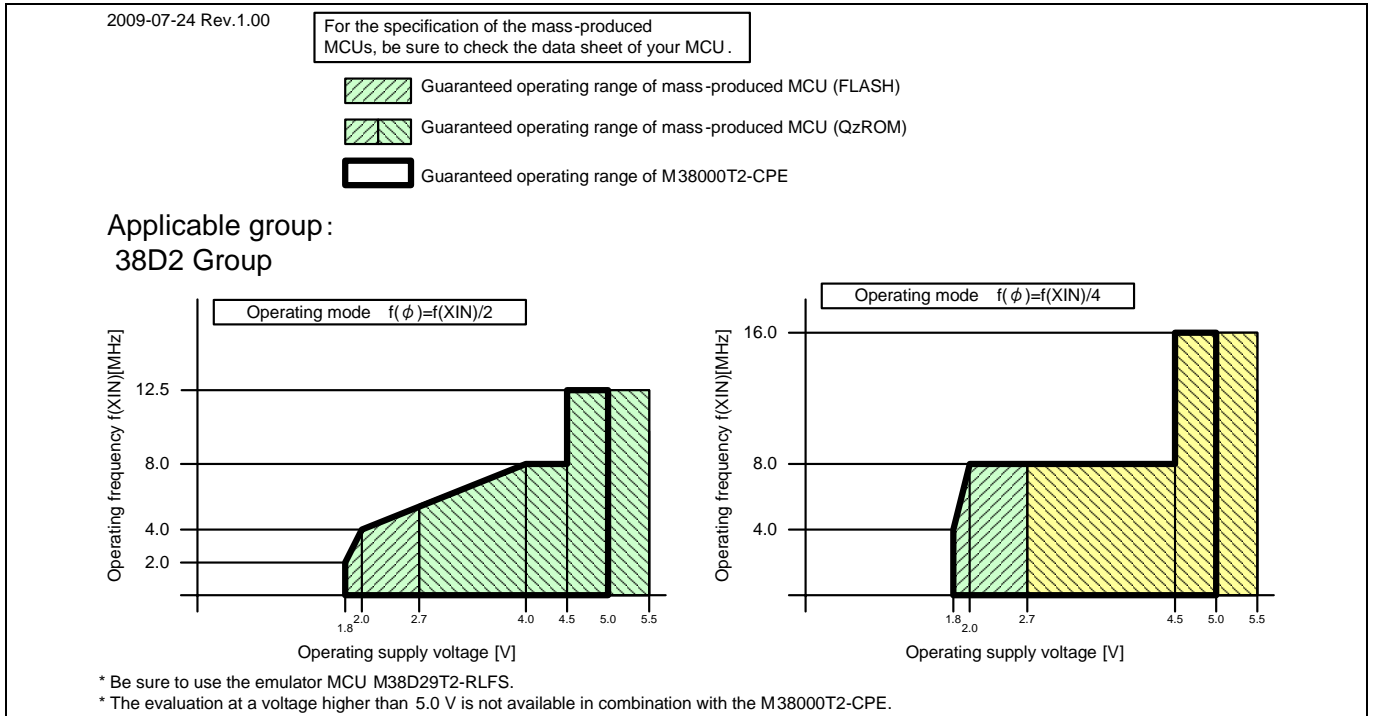

Figure 4.13 Operating conditions of the M38D29T2-RLFS

(14) M38D59T-RLFS

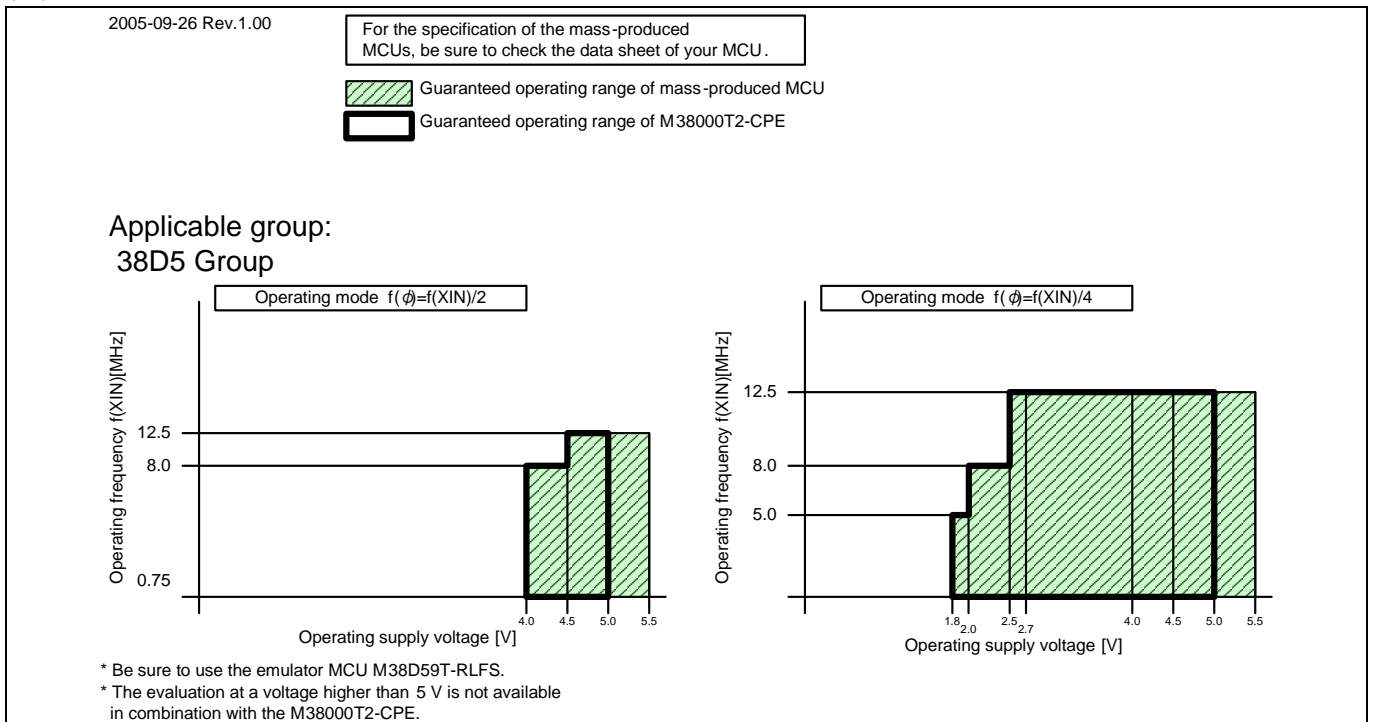

Figure 4.14 Operating conditions of the M38D59T-RLFS

(15) M38C89RLFS

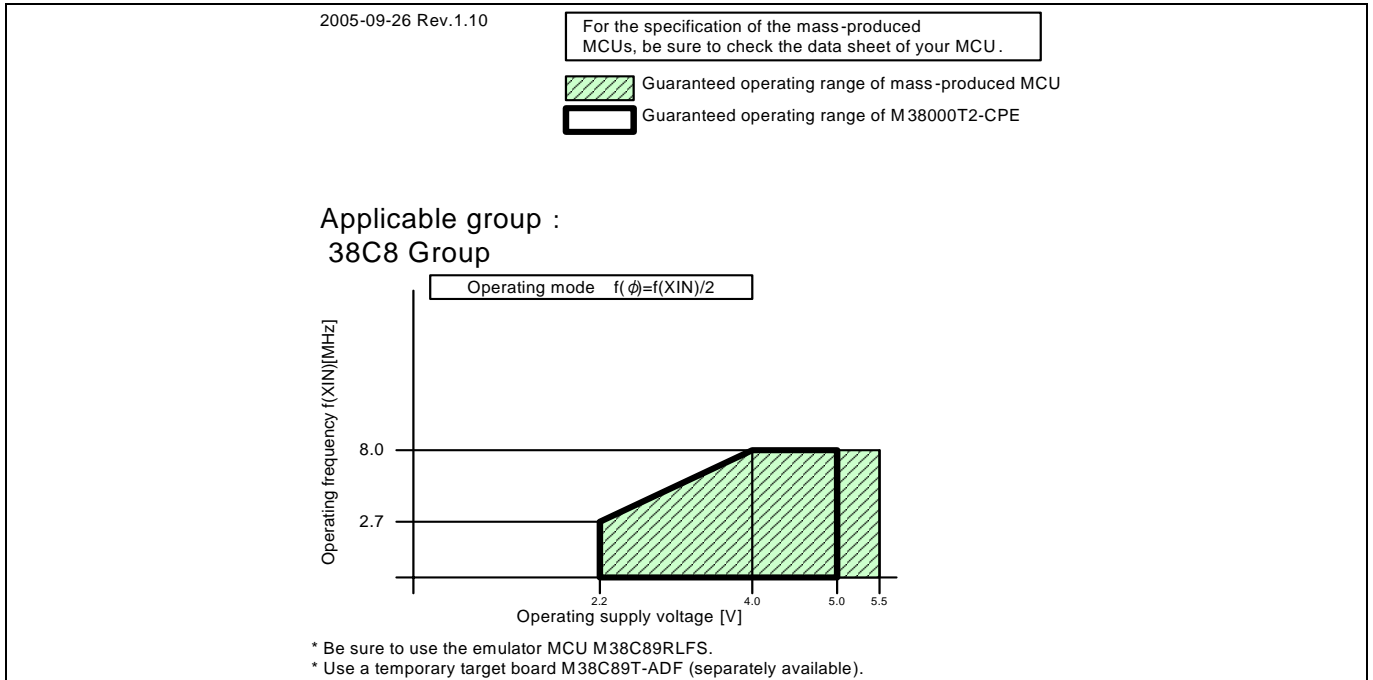

Figure 4.15 Operating conditions of the M38C89RLFS

(16) M38K09RFS

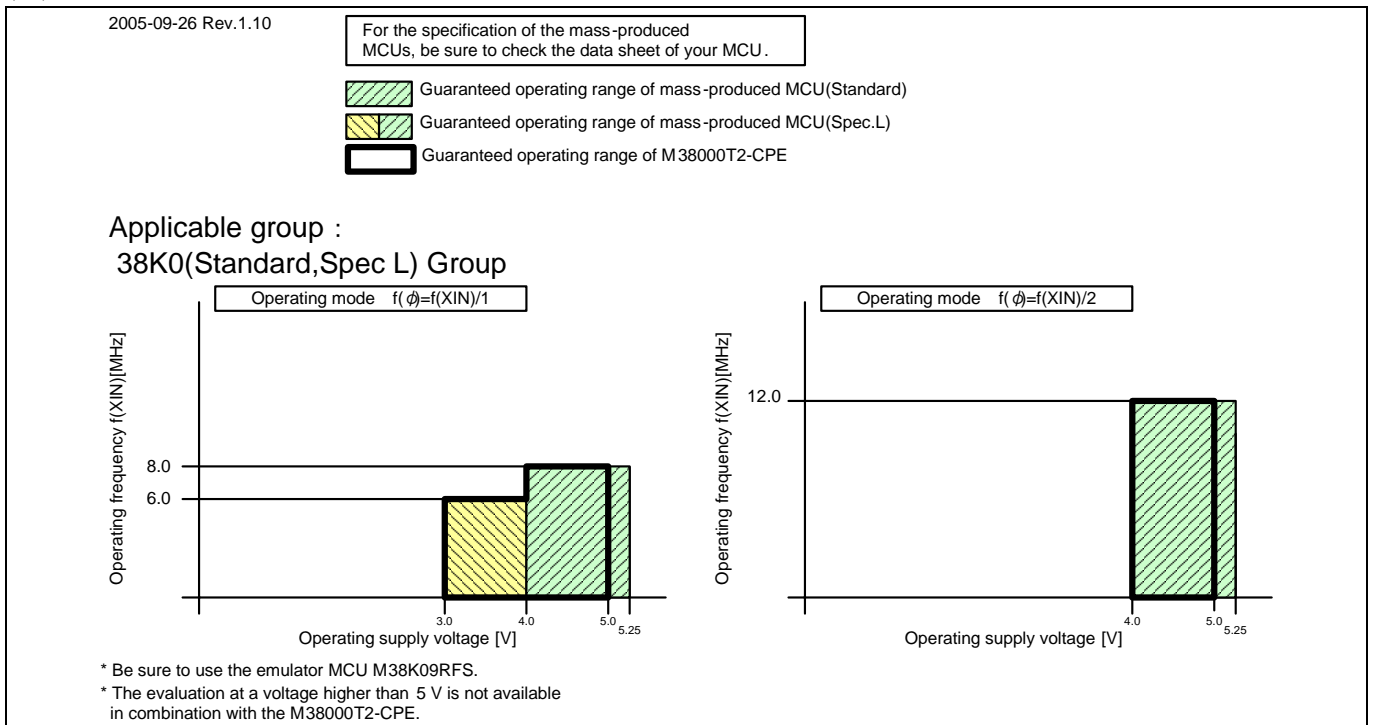

Figure 4.16 Operating conditions of the M38K09RFS

(17) M38K29RFS

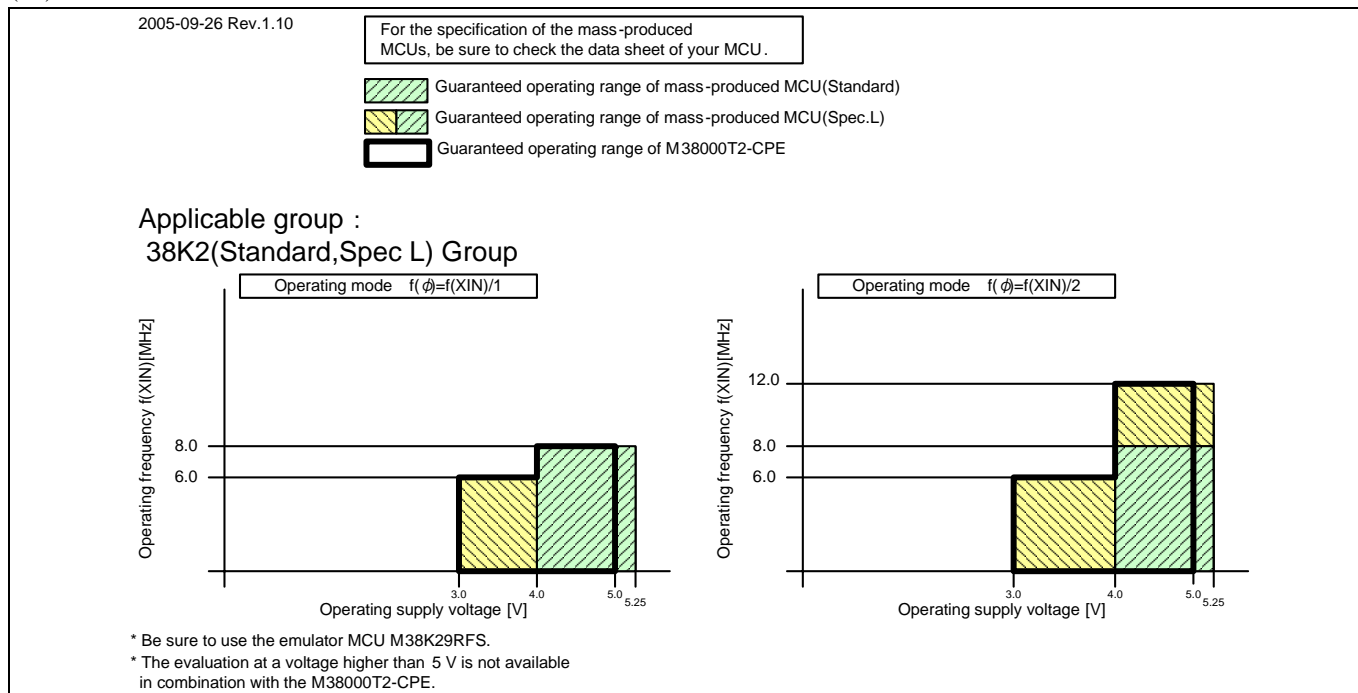

Figure 4.17 Operating conditions of the M38K29RFS

IMPORTANT

Note on the M38K09RLFS and M38K29RLFS:

- The M38K09RLFS and M38K29RLFS are standard type MCUs. When debugging the L version MCUs, be concerned about the difference of specifications of the MCUs.

4.2.2 Operating Condition for the 7200 Series

(1) M37150ERSS

2005-09-26 Rev.1.10	For the specification of the mass-produced MCUs, be sure to check the data sheet of your MCU.
<p>Applicable group: M37150</p> <ul style="list-style-type: none"> * Guaranteed operating range of M38000T2-CPE At VCC = 4.5--5.0V: f(FSCIN)=3.58MHz or f(FSCIN)=4.43MHz * Be sure to use the emulator MCU M37150ERSS. * The evaluation at a voltage higher than 5.0 V is not available in combination with the M38000T2-CPE. 	

Figure 4.18 Operating conditions of the M37150ERSS

(2) M37151ERSS

2005-09-26 Rev.1.10	For the specification of the mass-produced MCUs, be sure to check the data sheet of your MCU.
<p>Applicable group: M37151</p> <ul style="list-style-type: none"> * Guaranteed operating range of M38000T2-CPE At VCC = 4.5--5.0V: f(Xin)=8.0MHz * Be sure to use the emulator MCU M37151ERSS. * The evaluation at a voltage higher than 5.0 V is not available in combination with the M38000T2-CPE. 	

Figure 4.19 Operating conditions of the M37151ERSS

(3) M37160ERSS

2005-09-26 Rev.1.10	For the specification of the mass-produced MCUs, be sure to check the data sheet of your MCU.
<p>Applicable group: M37160</p> <ul style="list-style-type: none"> * Guaranteed operating range of M38000T2-CPE At VCC = 4.5--5.0V: f(FSCIN)=4.43MHz * Be sure to use the emulator MCU M37160ERSS. * The evaluation at a voltage higher than 5.0 V is not available in combination with the M38000T2-CPE. 	

Figure 4.20 Operating conditions of the M37160ERSS

(4) M37161ERSS

2005-09-26 Rev.1.10	For the specification of the mass-produced MCUs, be sure to check the data sheet of your MCU.
<p>Applicable group: M37161</p> <ul style="list-style-type: none"> * Guaranteed operating range of M38000T2-CPE At VCC = 4.5--5.0V: f(Xin)=8.0MHz * Be sure to use the emulator MCU M37161ERSS. * The evaluation at a voltage higher than 5.0 V is not available in combination with the M38000T2-CPE. 	

Figure 4.21 Operating conditions of the M37161ERSS

(5) M37221ERASS

2005-09-26 Rev.1.10	For the specification of the mass-produced MCUs, be sure to check the data sheet of your MCU.
<p>Applicable group: M37221</p> <ul style="list-style-type: none"> * Guaranteed operating range of M38000T2-CPE At VCC = 4.5--5.0V: f(Xin)=8.0MHz * Be sure to use the emulator MCU M37221EARSS. * The evaluation at a voltage higher than 5.0 V is not available in combination with the M38000T2-CPE. 	

Figure 4.22 Operating conditions of the M37221ERASS

(6) M37225ERSS

2005-09-26 Rev.1.10	For the specification of the mass-produced MCUs, be sure to check the data sheet of your MCU.
<p>Applicable group: M37225</p> <ul style="list-style-type: none"> * Guaranteed operating range of M38000T2-CPE At VCC = 4.5--5.0V: f(FSCIN)=8.0MHz * Be sure to use the emulator MCU M37225ERSS. * The evaluation at a voltage higher than 5.0 V is not available in combination with the M38000T2-CPE. 	

Figure 4.23 Operating conditions of the M37225ERSS

(7) M37280ERSS

2005-09-26 Rev.1.10	For the specification of the mass-produced MCUs, be sure to check the data sheet of your MCU.
<p>Applicable group : M37280</p> <ul style="list-style-type: none"> * Guaranteed operating range of M38000T2-CPE At VCC = 4.5--5.0V: f(Xin)=8.0MHz * Be sure to use the emulator MCU M37280ERSS. * The evaluation at a voltage higher than 5.0 V is not available in combination with the M38000T2-CPE. 	

Figure 4.24 Operating conditions of the M37280ERSS

(8) M37281ERSS

2005-09-26 Rev.1.10	For the specification of the mass-produced MCUs, be sure to check the data sheet of your MCU.
<p>Applicable group: M37281</p> <ul style="list-style-type: none"> * Guaranteed operating range of M38000T2-CPE At VCC = 4.5--5.0V: f(Xin)=8.0MHz * Be sure to use the emulator MCU M37281ERSS. * The evaluation at a voltage higher than 5.0 V is not available in combination with the M38000T2-CPE. 	

Figure 4.25 Operating conditions of the M37281ERSS

4.2.3 Operating Condition for the 740 Series

(1) M37516RSS

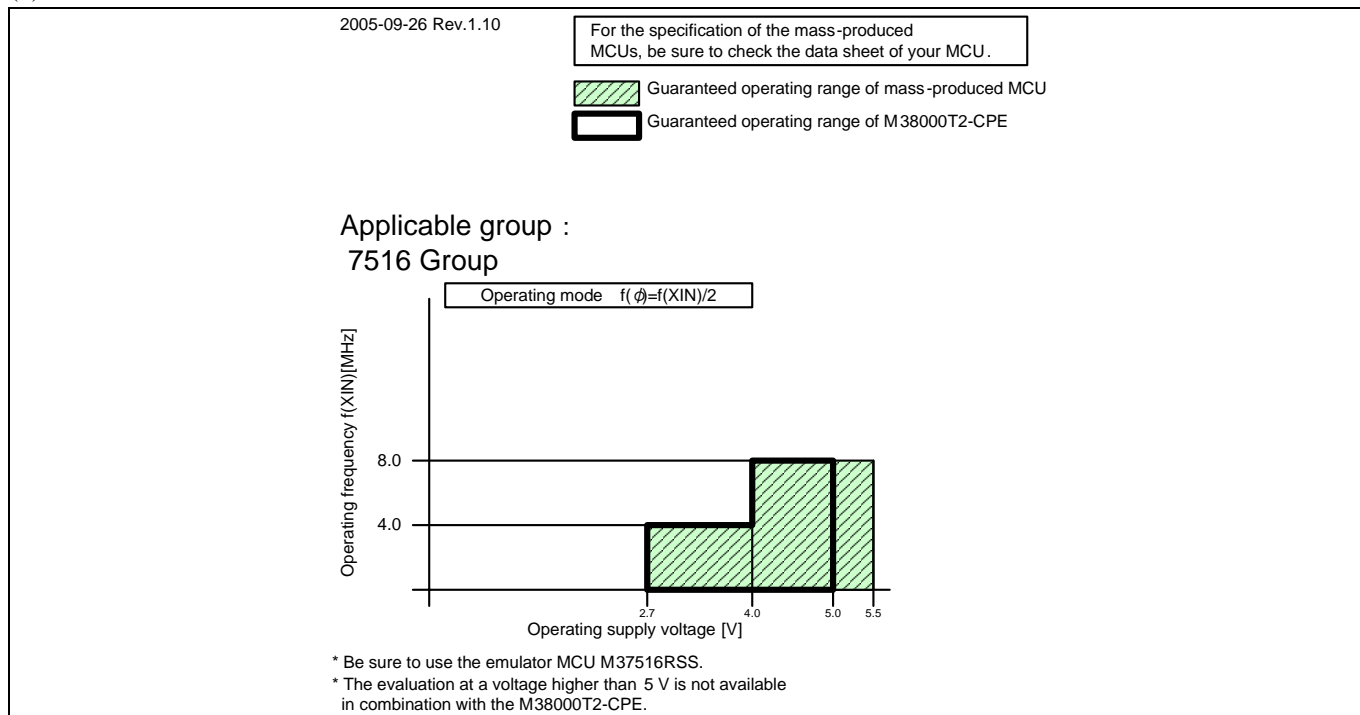

Figure 4.26 Operating conditions of the M37516RSS

(2) M37517RLSS

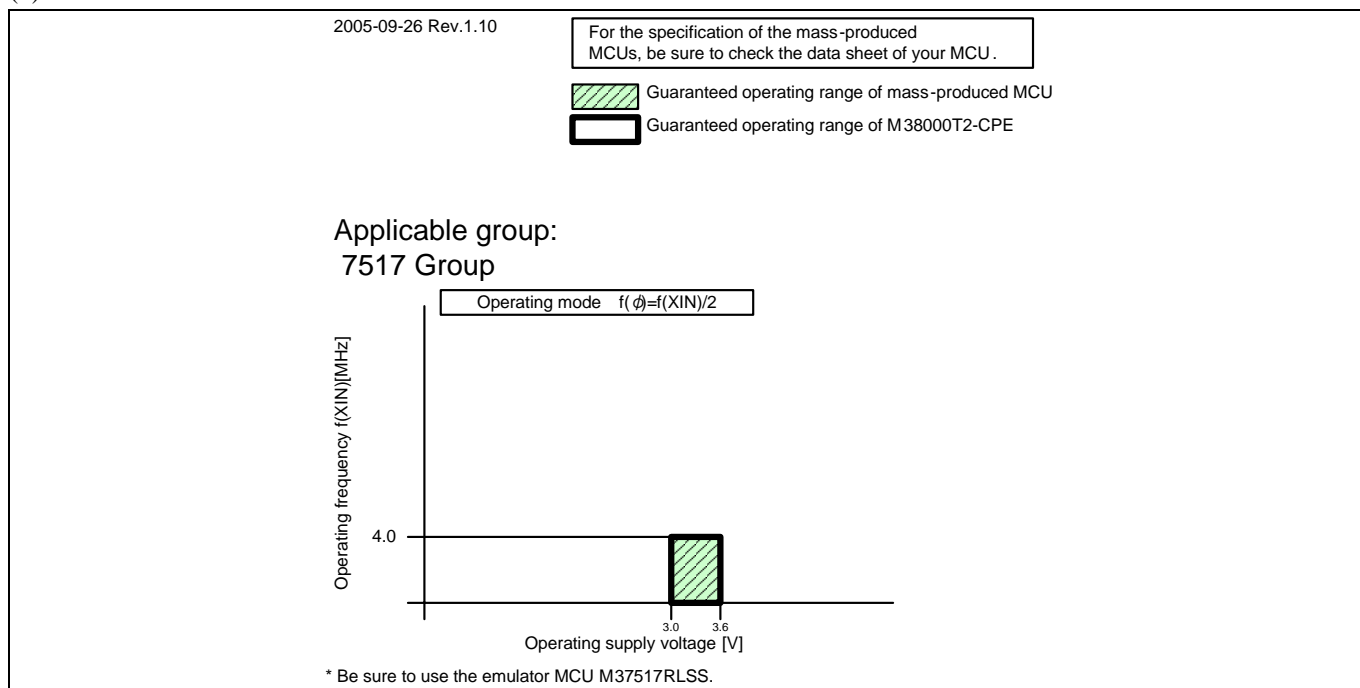

Figure 4.27 Operating conditions of the M37517RLSS

(3) M37534RSS

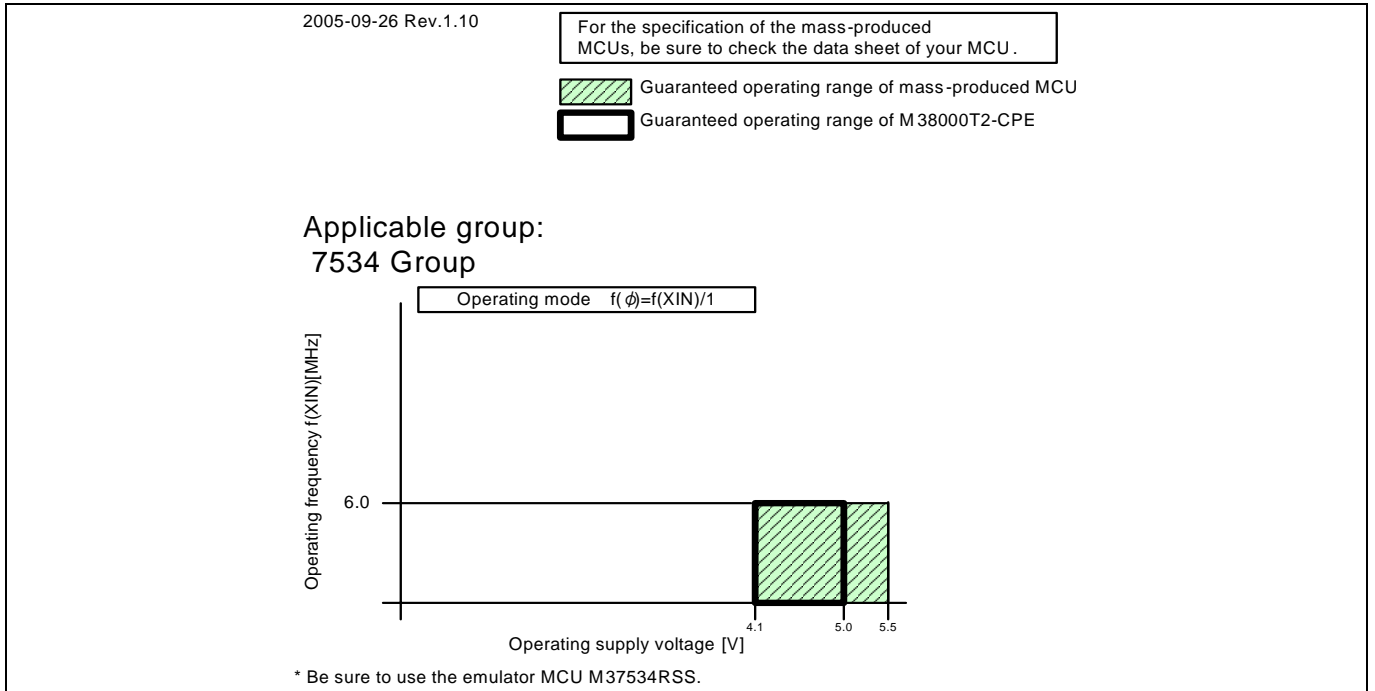

Figure 4.28 Operating conditions of the M37534RSS

(4) M37540RSS

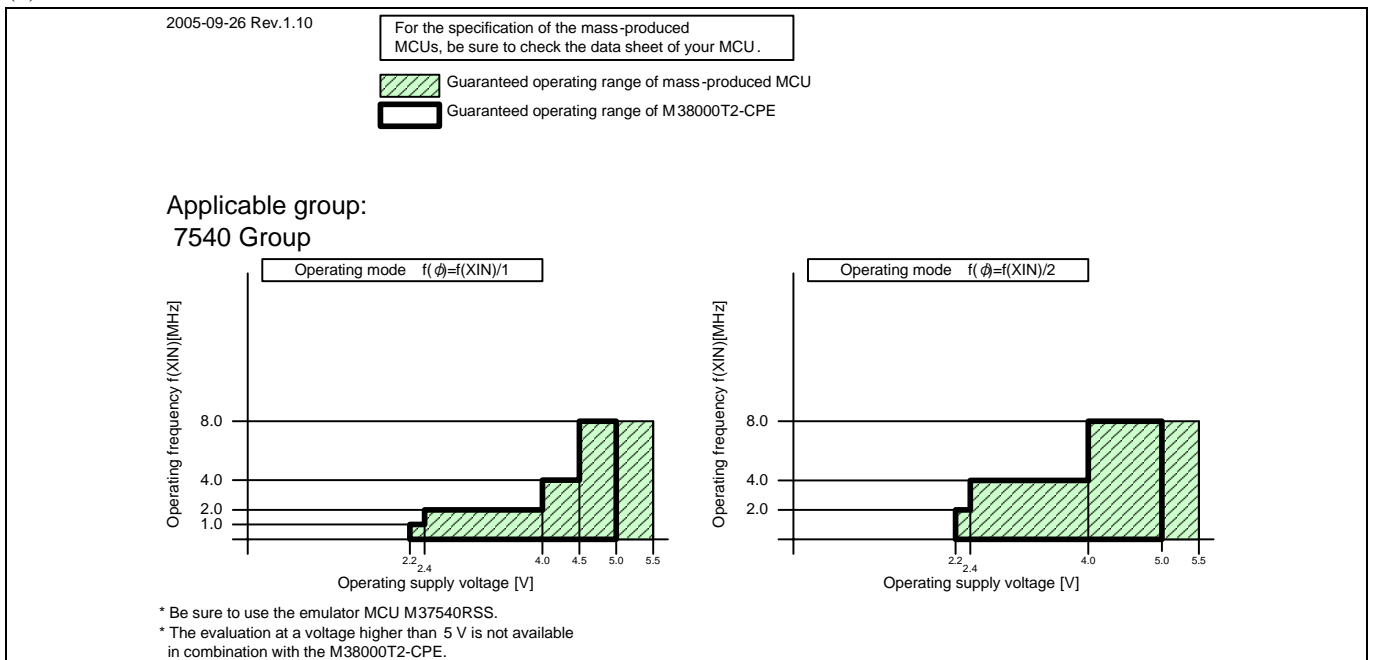

Figure 4.29 Operating conditions of the M37540RSS

(5) M37542RSS

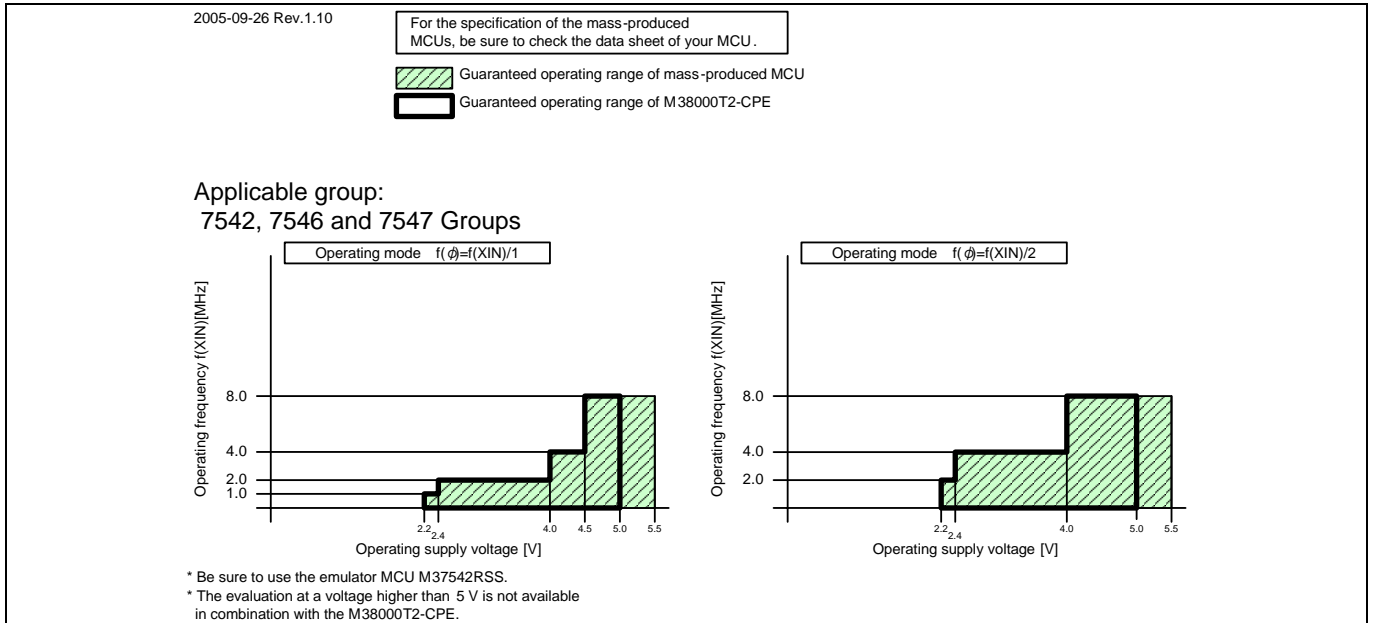

Figure 4.30 Operating conditions of the M37542RSS

(6) M37544RSS

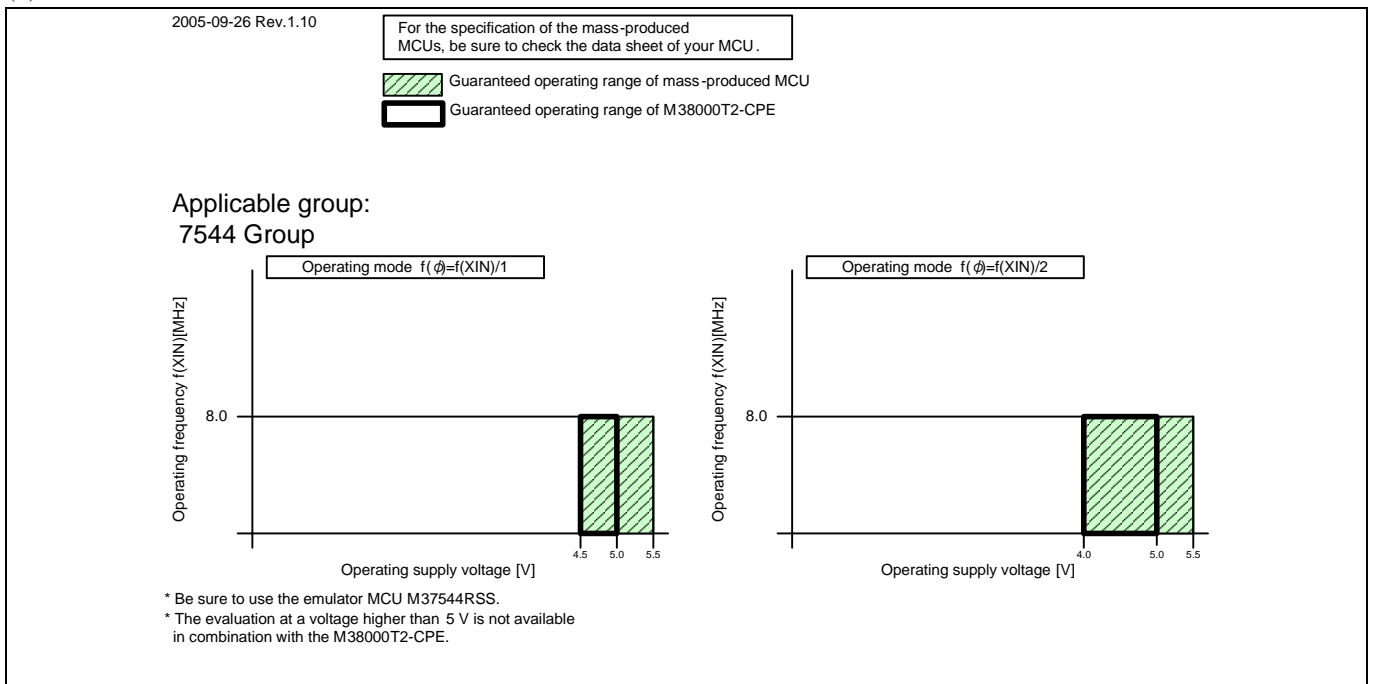

Figure 4.31 Operating conditions of the M37544RSS

IMPORTANT

Note on the M37542RSS:

- The M37542RSS is a standard type MCU. When debugging the 7546/7547 Groups QzROM version MCU, be concerned about the difference of specifications of the MCUs.

Note on the M37544RSS:

- The M37544RSS is a standard type MCU. When debugging the QzROM version MCU using the M37544RSS, be concerned about the difference of specifications of the MCUs.

(7) M37545RLSS

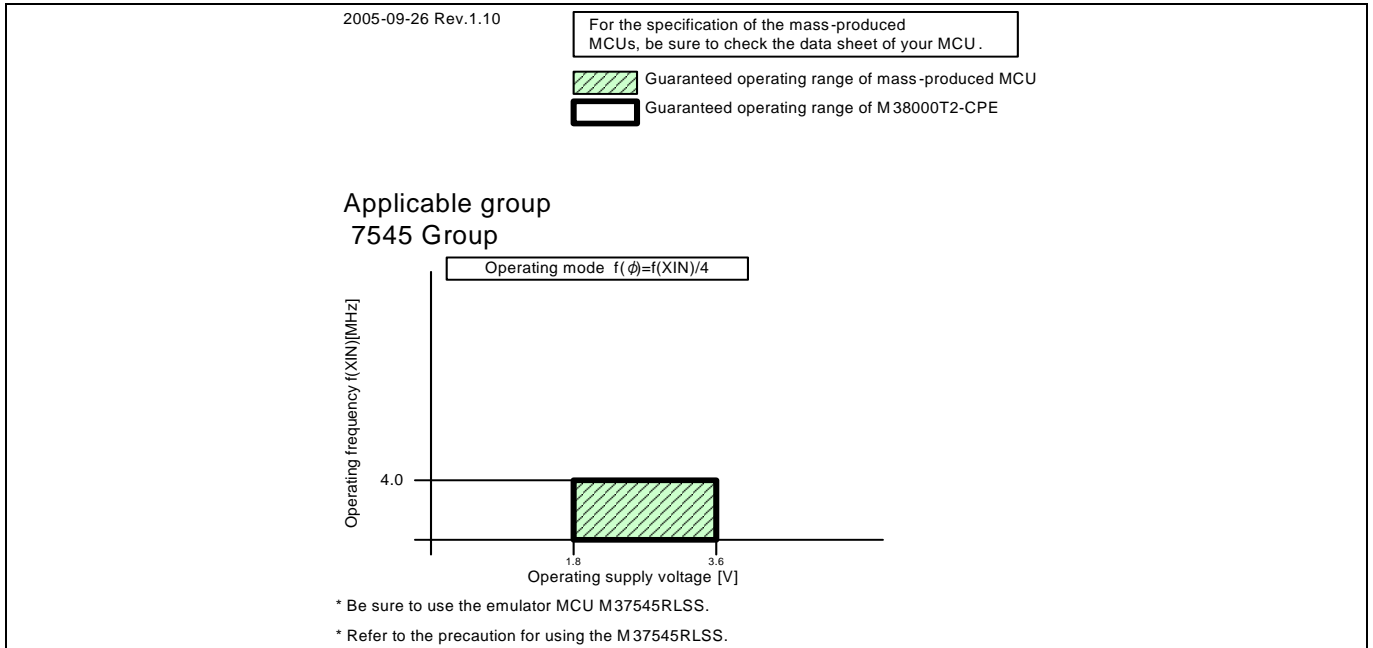

Figure 4.32 Operating conditions of the M37545RLSS

(8) M37549T-RLSS

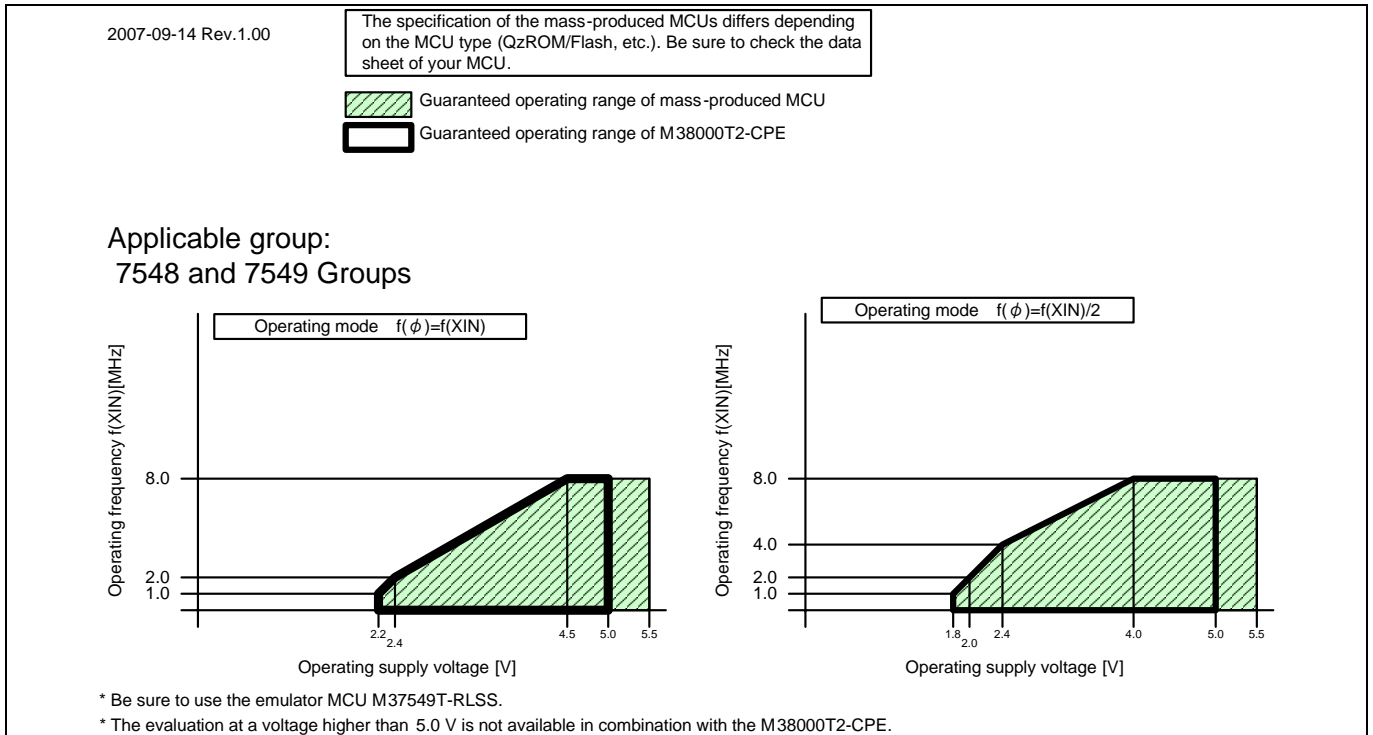

Figure 4.33 Operating conditions of the M37549T-RLSS

(9) M37560RFS

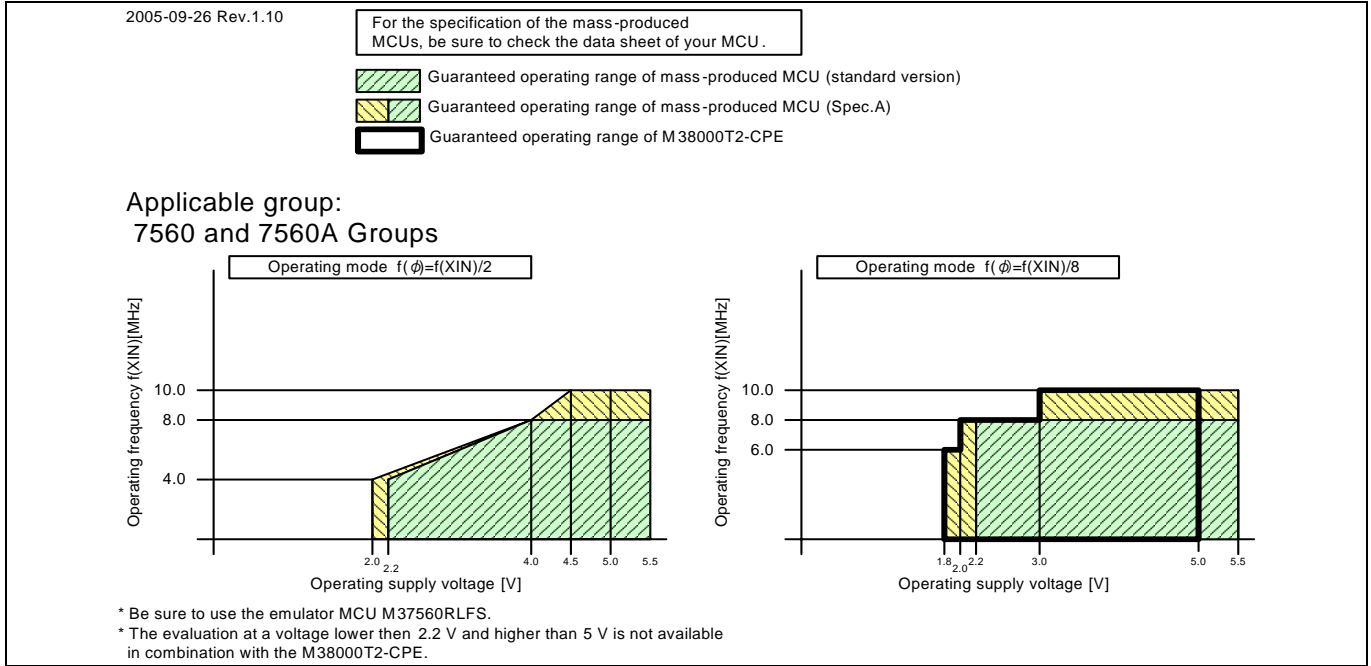

Figure 4.34 Operating conditions of the M37560RFS

4.3 Differences between the Actual MCU and Emulator

Differences between the actual MCU and emulator are shown below. When debugging the MCU using this product, be careful about the following precautions.

IMPORTANT

Note on Differences between the Actual MCU and Emulator:

- Operations of the emulator system differ from those of actual MCUs as listed below.
 - (1) Reset condition
 - (2) Initial values of internal resource data of an MCU at power-on
When power is turned on, the ROM areas (4000h to FFFFh) of the emulator are defaulted to EAh (NOP instruction).
 - (3) Capacities of the internal memories (ROM and RAM)
Because the internal ROM is emulated by the emulation memory, the capacity and assignment of the emulator's internal memories differ from those of the actual MCU.
 - (4) Register values after command reset and turning the power on
With the emulator system, when the power is turned on or after command reset, the emulator's register values are defaulted to FFh.
 - (5) Stack pointer value after command reset
With the emulator system, the stack address listed in the MCU file is used as an initial value of the stack pointer after the command reset.
 - (6) Power-on reset
You can reset this emulator system by the reset command of the 740 Compact Emulator Debugger, however, this emulator system cannot emulate operation at a power-on reset. Therefore, check the operation at a power-on reset using an actual MCU.
 - (7) A/D conversion, D/A conversion
As A/D converters have a pitch converter board between the emulator MCU and the user system, some characteristics are slightly different from those of the actual MCU.
 - (8) BRK instruction interrupt vector table addresses
As the emulator uses the BRK instruction interrupt table addresses, when data is read out from these addresses, the data are different from expected values.

Note on RESET# Input:

- Do not set the target reset signal to "Low" during the user program is stopped or run-time debug command is executed excluding the user program is executed (while RUN status LED of the emulator upper panel is ON). Otherwise the emulator may malfunction or some data of the emulation memory may be rewritten. If setting the target reset signal to "Low" during the user program is stopped or run-time debug command is executed, reset the system.

Notes on BRK Instruction:

- The BRK instruction cannot be used.
- The vector address value of the BRK instruction cannot be changed.

Note on Software Breaks:

- Software breaks replace the original instruction with the BRK instruction that generates the BRK interrupt. When the address that sets the software break is viewed in the dump window etc. while executing the programs, the BRK instruction "00h" is displayed. When trace result are viewed in the bus display, "00h" is displayed by fetching (by instruction) the address that sets the software break, however in the reverse assembly display, the "BRK" instruction is displayed.

IMPORTANT

Notes on Watchdog Timer:

- Watchdog timers cannot be used with this product.
- MCU watchdog timers can only be used during program execution (free running). Disable watchdog timers in all other program operations (break, dump, forced stop, etc.).
- If the user system has a watchdog timer in its reset circuit, disable it when you use the emulator.

Notes on RAM Capacity:

- Since this product uses the internal RAM of the emulator MCU, its RAM size differs from that of the actual MCU.
- When the RAM area of the target MCU is larger than the RAM in the emulator MCU, set the marginal area to "INT" by the MAP command of the emulator debugger. The emulation memory can be used as alternative for the shortage.

Note on Inspecting/Setting Registers

- Some registers exceeding 8 bits in length such as the 16-bit timer require that they be read and written to in designated byte orders.

When inspecting: Data must be read out the upper byte first and then the lower byte.

When setting: Data must be written the lower byte first and then the upper byte.

When you inspect or set these registers, be aware that if one of the following debug operations is performed, they cannot be inspected or set normally.

- (1) Register values are inspected or set in the Dump or the Memory window of the emulator debugger.
- (2) Only the upper or the lower byte alone is inspected or set in the emulator debugger before a break.
- (3) The instructions to inspect or set these registers are single-stepped in the emulator debugger.

In this product, data are read out the lower address first and then the upper address. Since this read byte order differs from the designated read byte order of the MCU, data cannot be read normally.

For writes too, since the window is updated after the upper or lower side of a register is set and a read operation occurs in the middle of a write to the MCU, data cannot be written to the register normally.

In the case of (2) and (3) too, since a read and write to the MCU occurs upon a program break, data cannot be written to and read out normally.

Please be sure to use the realtime RAM monitor function to verify reads and writes to these registers.

Note that the registers exceeding 8 bits in length which have had their read and write byte sequences designated include the 16-bit timers (Timer X and Timer Y), the AD conversion register (read-only register), and the protected registers.

Note on Stack Area:

- With this emulator, use stack specified by the stack pointer S consume 3 bytes. If there is not enough use stack area, using other areas not designed for use as stacks (SFR area, RAM area that stored data or ROM area) can damage the use program or destabilized emulator control. Therefore, ensure a maximum +3 bytes of the area used the user program as user stack area.

Note on Final Evaluation:

- Be sure to evaluate your system and make final confirmation with a CS (Commercial Sample) version MCU.

4.4 Connection Diagram

4.4.1 Connection Diagram of the Compact Emulator

Figure 4.35 shows the connection diagram of the M38000T2-CPE.

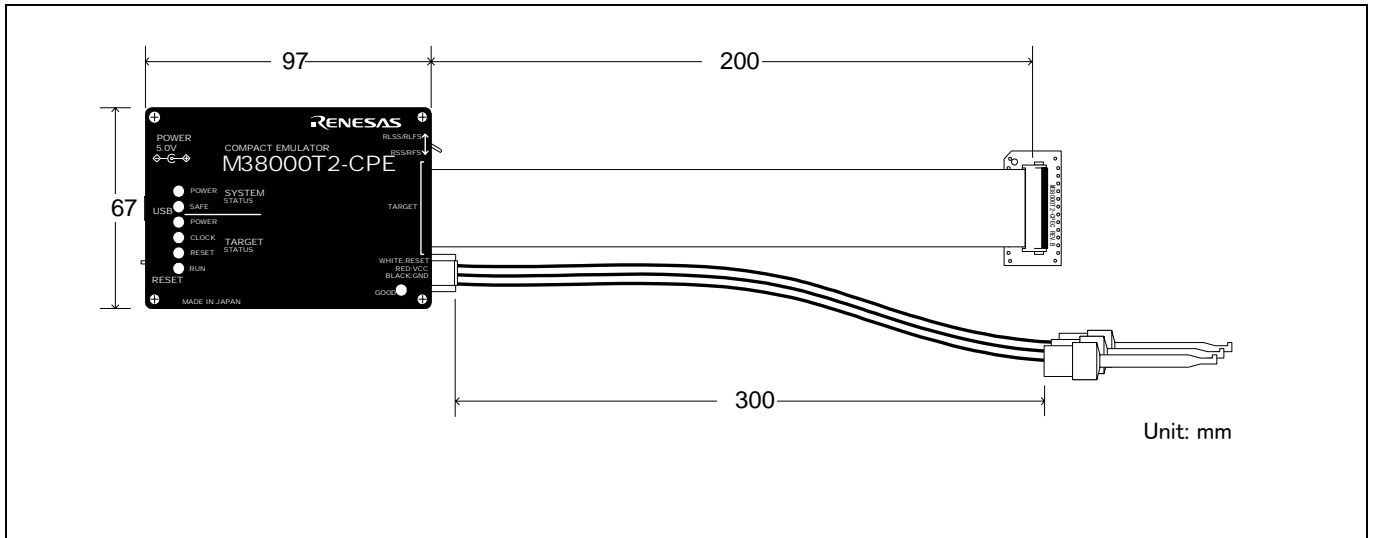

Figure 4.35 Connection diagram of the compact emulator

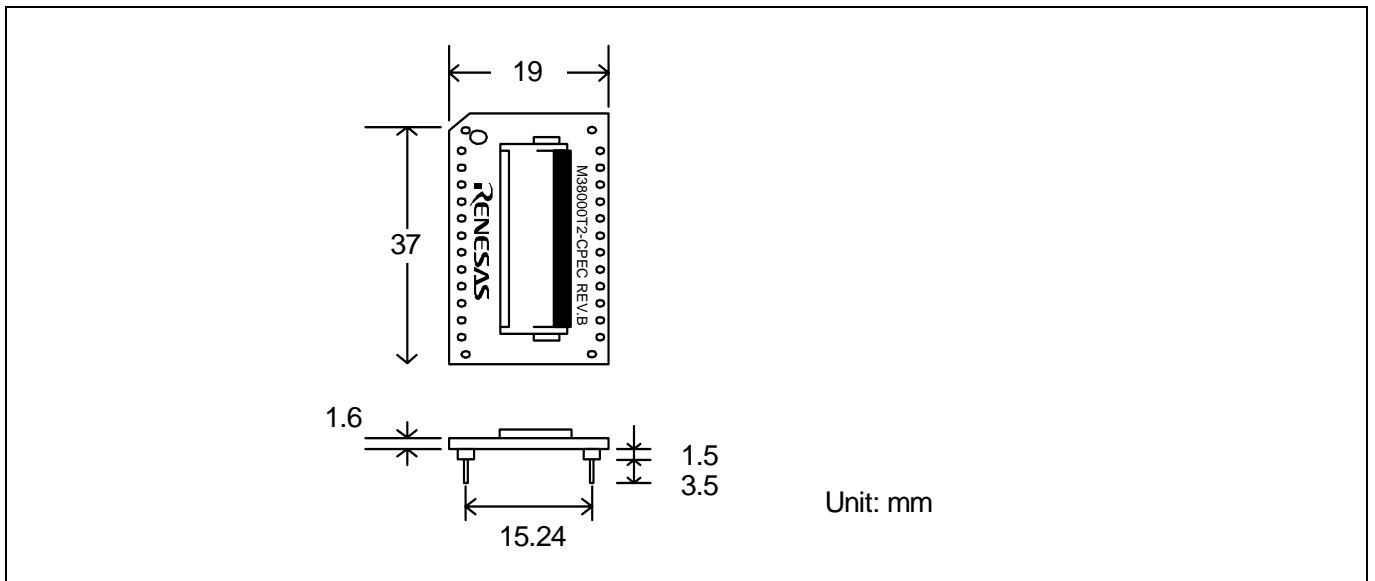

Figure 4.36 Connection diagram of the tip of the probe (M38000T2-CPEC)

4.5 Notes on Using This Product

Notes on using this product are listed below. When debugging the MCU using this product, be careful about the following precautions.

IMPORTANT

Note on the User System:

- For starting up the emulator normally, the following are needed.
 - (1) Connection to the emulator MCU
 - (2) Power supply to the emulator MCU (Vcc and GND)
 - The Vcc pin is connected to the user system to observe the voltage of the user system. Therefore the emulator cannot supply the power to the user system. Design you system so that the user system is powered separately.
 - The voltage of the user system should be within the MCU's specified range and between +1.8 to 5.0 V.
 - Do not change the voltage of the user system after turning on the power.
 - (3) Clock supply to the emulator MCU
 - (4) RESET pin

When debugging with the M38000T2-CPE, use either an open-drain type reset IC or CR reset circuit. The recommended pull-up value is about 10kΩ. The MCU can be reset by outputting "L" to the user system through the reset clip on the M38000T2-CPE. However, if the reset circuit on the user system is an H-output type RESET IC, it cannot be set to "L" and the emulator will not operate properly.
 - (5) Other pins

According to the MCU specifications, terminate the Vref pin (if the MCU has it) or CNVss pins properly.

Notes on the Self-check:

- If the self-check does not result normally, the emulator may be damaged. Then contact your local distributor.
- Run the self-check with the user system connected.

Note on Quitting the 740 Compact Emulator Debugger:

- To restart the emulator debugger, always shut power to the emulator main unit off once and then on again.

Note on Downloading the Firmware:

- Do not shut OFF power while firmware is being downloaded. Doing so, the emulator will not start up properly. If power is shut off by mistake, redownload the firmware again.

Note on the Clock Supply:

- The clock supplied to the emulator MCU is available from only the oscillator circuit in the user system.

Notes on the User System (Power Supply, Order of Powering On):

- Before powering on your emulator system, check that the host machine, the emulator, the converter board and user system are all connected correctly. Next, turn on the power to each equipment following the procedure below.
 - (1) Turn ON/OFF the user system and the emulator as simultaneously as possible.
 - (2) When the emulator debugger starts up, check the target status LEDs on the emulator to see if this product is ready to operate.

Is the power supplied to the emulator MCU?	Check that target status LED (POWER) is ON.
Is the clock supplied to the emulator MCU?	Check that target status LED (CLOCK) is ON.
Whether RESET operation on the emulator MCU is possible?	Check that target status LED (RESET) is OFF.

IMPORTANT

Notes on Stop and Wait Modes:

- The STP and WIT instructions are executed as a “NOP instruction” no matter whether the program is single-stepped or over-stepped.
- During the stop or wait mode, debug commands (break, dump, single-step, stop, etc.) with the emulator debugger cannot be executed. Wait until the emulator debugger returns from stop or wait mode by reset input or interrupt, etc. from the user system before executing the command. Also, debug command cannot be executed when the target clock is not oscillating. The internal clock ϕ can stop in the following cases.
 - When the system clock of the emulator MCU is not oscillating
 - When the emulator MCU is in stop mode
 - When the emulator MCU is in wait mode

Notes on MCU Status While a Program Is Stopped:

- With this emulator, the program is stopped with a loop program to a specified address. Note that, in this case, peripheral circuits (e.g. timer) are still operating.
- If an interrupt request is generated at any time other than when the program is being executed (while the user program is paused or a debug program is running), the interrupt is not generated because the emulator disables interrupts. However, the interrupt request bit can be set. And the interrupt request bit cannot be cleared by the emulator.

Notes on Step Execution

- Interrupts are disabled during single-step execution. Accordingly, the interrupts are not generated because the emulator disables interrupts. However, an interrupt request bit can be set. And the internal request bit cannot be cleared by the emulator.
- The single-steps and breaks cannot be executed in the internal RAM area.

Notes on MAP References and Settings:

- The initial MAP settings when the emulator debugger starts up are as follows.
 - 0000h to 3FFFh: EXT
 - 4000h to FFFFh: INT (emulation memory available)
- With this product, you can map memory by 64 bytes
- Be sure to set the internal RAM of MCU and SFR area to “EXT”.
When the RAM area of the emulator MCU is larger than the RAM in the emulator MCU, set the marginal area to “INT”.
- Writing into the emulation memory allocated to 1000h -- FFFFh is protected by the ROM protect function of the emulator.

Note on Reset Command Execution During User Program Execution:

- The real-time aspect of the user program is not guaranteed when debug commands such as dump are executed during user program execution.

Note on Flash Memory and EPROM Modes:

- The emulator does not emulate flash memory and EPROM modes. Also, the emulator does not emulate CPU rewrite mode in flash memory mode.

IMPORTANT

Notes on CE Declaration of Conformity:

- Please use it with care described below.
 - * Electrostatic Discharge Precautions must be taken when handling the product.
 - * Must not be used within 30 meters of a domestic radio or television receiver.
 - * For correct operation of this product, it is recommended that Mobile phones are not used within 10 meters of this product system.
 - * This product should be powered down when not in use.
- This product generates, uses, and can radiate radio frequency energy and may cause harmful interference to radio communications.
- If this product causes harmful interference to radio or television reception, which can be determined by turning this product off or on, you are encouraged to try to correct the interference by one or more of the following methods;
 - * Ensure attached cables do not lie across the probe board and converter board.
 - * Reorient the receiving antenna.
 - * Increase the distance between the product and the receiver.
 - * Connect the product into an outlet on a circuit different from that to which the receiver is connected.
 - * Consult the dealer or experienced radio/TV technician for help.
- Attach the ferrite core included with this product close to the DC plug of the power cable. Without the ferrite core it may cause interference.
The power cable should be wound around the ferrite core as shown in the figure, and close the ferrite core until it clicks.

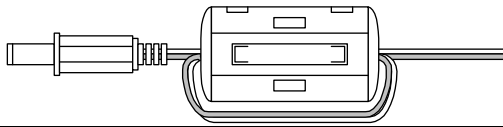

5. Troubleshooting

This chapter describes how to troubleshoot when this product does not work properly.

5.1 Flowchart to Remedy the Troubles

Figure 5.1 shows the flowchart to remedy the troubles from when power to the emulator is activated until the emulator debugger starts up. Check this while the user system is disconnected. For the latest FAQs visit the Renesas Tools Homepage.

<http://www.renesas.com/tools>

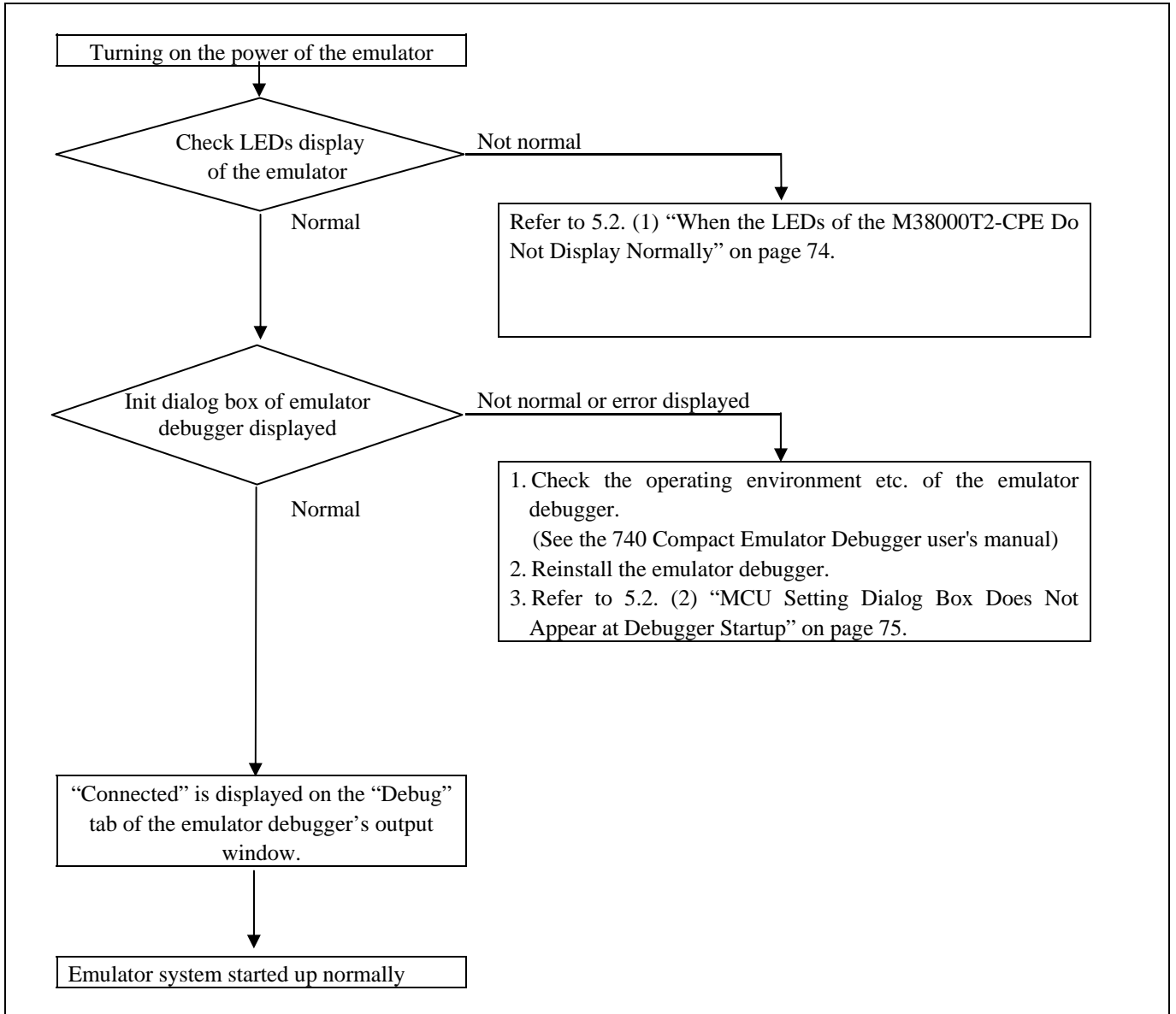

































Figure 5.1 Flowchart to remedy the troubles

5.2 When the Emulator Debugger Does Not Start Up Properly

(1) When the LEDs of the M38000T2-CPE Do Not Display Normally

Table 5.1 Errors LEDs show and their checkpoints (2)

Example  : ON  : OFF  : Blinking				Problem & Remedy
POWER	CLOCK	RESET	RUN	
				The emulator system is not working properly. - If the SAFE LED is blinking, startup the emulator debugger and download the firmware. - Check that the emulator is powered. - The emulator may be damaged. Contact your local distributor.
				The user system is not powered or the target status cables are not connected properly. - Check that the emulator is powered. - Check that the VCC and GND clips of target status cables are connected properly. - Check that the emulator MCU type selection switch is set properly. - Check that the probe board and the user system are connected properly.
				The emulator MCU type selection switch is not set properly. - Check that the VCC and GND clips of target status cables are connected properly. - Check that the probe board and the user system are connected properly.
				The target status cables are not connected properly. - Check that the VCC and GND clips of target status cables are connected properly.
				The reset command is not executed properly. - Check that the reset pin is not held "H". - Check that the "H" output type reset IC is not used in the reset circuit. With this emulator, the "H" output type reset IC cannot be used. - Check that the RESET clip of a target status cable is connected properly.
				The internal clock ϕ output is not executed properly. - Check that the power supply voltage of the user system is within the MCU's specified range. - Check that the oscillating frequency of the user system is within the MCU's specified range.
				The reset command cannot be canceled properly. - Check that the reset pin is not held "L". - Check that the pullup resistor of about 10 k Ω is connected to the reset circuit.
Others				The emulator system is not working properly. - The emulator may be damaged. Contact your local distributor

(2) MCU Setting Dialog Box Does Not Appear at Debugger Startup

Table 5.2 Checkpoints of errors at debugger startup

Error	Checkpoint
Cannot connect with the target.	<p>The emulator debugger cannot be connected to the emulator properly.</p> <ul style="list-style-type: none"> - Check that the emulator's target status LEDs. If they are blinking, the emulator has not started up properly. Check the settings explained in "5.2 (1) When the LEDs of the M38000T2-CPE Do Not Display Normally" (page 74). - Check that the USB cable is connected properly. - Check that the USB driver is installed properly.
Target MCU is not under control. Please execute RESET command.	<p>The emulator MCU does not work properly because of some kind of problem.</p> <ul style="list-style-type: none"> - Recheck the connection of the emulator. - Check the clock, reset circuit and power supply of the user system.
Target Missing or Connection Controlled.	Contact your local distributor.
Communication error occurred. Data was not sent to the target.	<ul style="list-style-type: none"> - Check the target status LED display. If the LED is blinking, the emulator did not start up normally. See "2.6.9 LED Display When the Emulator Starts Up Normally" (page 29). - Check that the USB cable is connected properly. See "2.5 Connecting the Host Machine" (page 24).

5.3 How to Request for Support

After checking the items in "5 Troubleshooting", fill in the text file which is downloaded from the following URL, then send the information to your local distributor.

<http://tool-support.renesas.com/eng/toolnews/registration/support.txt>

For prompt response, please specify the following information:

(1) Operating environment

- Operating voltage: _____ [V]
- Operating frequency: _____ [MHz] (Clock division ratio: _____)
- Emulator MCU:
- Emulator MCU type selection switch setting: RFS/RSS, RLFS/RLSS
- Firmware version: _____
- Emulator debugger type and its version

(2) Product Information

- Target MCU name: _____
- Emulator name: _____
- Optional product name: _____

(3) Condition

- The emulator debugger starts up/does not start up
- The error is detected/not detected in the self-check
- Frequency of errors: always/frequency (_____)

(4) Problem

6. Maintenance and Guarantee

This chapter describes how to maintenance, repair provisions and how to request for repair.

6.1 User Registration

When you purchase our product, be sure register as a user. For user registration, refer to “User registration” (page 12) of this user's manual.

6.2 Maintenance

- (1) If dust or dirt collects on this product, wipe it off with a dry soft cloth.
Do not use thinner or other solvents because these chemicals can cause the surface coating to separate.
- (2) When you do not use this product for a long period, remove the power supply, the host machine and the user system.

6.3 Guarantee

If your product becomes faulty within one year after its purchase while being used under good conditions by observing "IMPORTANT" and "Precautions for Safety" described in this user's manual, we will repair or replace your faulty product free of charge. Note, however, that if your product's fault is raised by any one of the following causes, we will repair it or replace it with new one with extra-charge:

- Misuse, abuse, or use under extraordinary conditions
- Unauthorized repair, remodeling, maintenance, and so on
- Inadequate user's system or misuse of it
- Fires, earthquakes, lightning, storm, flood and other unexpected disasters and damages.

In the above cases, contact your local distributor. If your product is being leased, consult the leasing company or the owner.

6.4 Repair Provisions

Repair with extra-charge

The products elapsed more than one year after purchase can be repaired with extra-charge.

Replacement with extra-charge

If your product's fault falls in any of the following categories, the fault will be corrected by replacing the entire product instead of repair, or you will be advised to purchase new one, depending on the severity of the fault.

Faulty or broken mechanical portions

Flaw, separation, or rust in coated or plated portions

Flaw or cracks in plastic portions

Faults or breakage caused by improper use or unauthorized repair or modification

Heavily damaged electric circuits due to overvoltage, overcurrent or shorting of power supply

Cracks in the printed circuit board or burnt-down patterns

Wide range of faults that makes replacement less expensive than repair

Unlocatable or unidentified faults

Expiration of the repair period

When a period of one year elapses after the model was dropped from production, repairing products of the model may become impossible.

Transportation fees at sending your product for repair

Please send your product to us for repair at your expense.

6.5 How to Make Request for Repair

If your product is found faulty, fill in a Repair Request Sheet downloadable from the following URL. And email the sheet and send the product to your local distributor.

<http://www.renesas.com/repair>

CAUTION

Note on Transporting the Product:



When sending your product for repair, use the packing box and cushion material supplied with this product when delivered to you and specify handling caution for it to be handled as precision equipment. If packing of your product is not complete, it may be damaged during transportation. When you pack your product in a bag, make sure to use conductive polyvinyl supplied with this product (usually a blue bag). When you use other bags, they may cause a trouble on your product because of static electricity.

M38000T2-CPE User's Manual

Publication Date: Oct 16, 2010 Rev.6.00

Published by: Renesas Electronics Corporation

Edited by: Microcomputer Tool Development Department 2
Renesas Solutions Corp.



SALES OFFICES

Renesas Electronics Corporation

<http://www.renesas.com>

Refer to "<http://www.renesas.com/>" for the latest and detailed information.

Renesas Electronics America Inc.
2880 Scott Boulevard Santa Clara, CA 95050-2554, U.S.A.
Tel: +1-408-588-6000, Fax: +1-408-588-6130

Renesas Electronics Canada Limited
1101 Nicholson Road, Newmarket, Ontario L3Y 9C3, Canada
Tel: +1-905-898-5441, Fax: +1-905-898-3220

Renesas Electronics Europe Limited
Dukes Meadow, Millboard Road, Bourne End, Buckinghamshire, SL8 5FH, U.K
Tel: +44-1628-585-100, Fax: +44-1628-585-900

Renesas Electronics Europe GmbH
Arcadiastrasse 10, 40472 Düsseldorf, Germany
Tel: +49-211-65030, Fax: +49-211-6503-1327

Renesas Electronics (China) Co., Ltd.
7th Floor, Quantum Plaza, No.27 ZhiChunLu Haidian District, Beijing 100083, P.R.China
Tel: +86-10-8235-1155, Fax: +86-10-8235-7679

Renesas Electronics (Shanghai) Co., Ltd.
Unit 204, 205, AZIA Center, No.1233 Lujiazui Ring Rd., Pudong District, Shanghai 200120, China
Tel: +86-21-5877-1818, Fax: +86-21-6887-7858 / -7898

Renesas Electronics Hong Kong Limited
Unit 1601-1613, 16/F, Tower 2, Grand Century Place, 193 Prince Edward Road West, Mongkok, Kowloon, Hong Kong
Tel: +852-2886-9318, Fax: +852 2886-9022/9044

Renesas Electronics Taiwan Co., Ltd.
7F, No. 363 Fu Shing North Road Taipei, Taiwan
Tel: +886-2-8175-9600, Fax: +886 2-8175-9670

Renesas Electronics Singapore Pte. Ltd.
1 harbourFront Avenue, #06-10, Keppel Bay Tower, Singapore 098632
Tel: +65-6213-0200, Fax: +65-6278-8001

Renesas Electronics Malaysia Sdn.Bhd.
Unit 906, Block B, Menara Amcorp, Amcorp Trade Centre, No. 18, Jln Persiaran Barat, 46050 Petaling Jaya, Selangor Darul Ehsan, Malaysia
Tel: +60-3-7955-9390, Fax: +60-3-7955-9510

Renesas Electronics Korea Co., Ltd.
11F, Samik Lavied' or Bldg., 720-2 Yeoksam-Dong, Kangnam-Ku, Seoul 135-080, Korea
Tel: +82-2-558-3737, Fax: +82-2-558-5141

M38000T2-CPE
User's Manual