

ZL2106EVAL1Z

Evaluation Board

AN1468
Rev 2.00
Sep 15, 2011

Description

The ZL2106 is an innovative power conversion and management IC that combines an integrated synchronous step-down DC-DC converter with key power and fault management functions in a small package, resulting in a flexible and integrated solution. The ZL2106EVAL1Z platform allows evaluation of the features in the highly configurable ZL2106 in either stand-alone mode or via an I²C/SMBus™ interface.

A USB-to-SMBus reference board can be used to connect the ZL2106EVAL1Z board to a PC. The PMBus command set is accessed by using the PowerNavigator™ evaluation software from a PC running Microsoft Windows.

Key Features

- Small, compact design
- PMBus™ control
- Pin-strap selection for stand-alone operation
- V_{OUT} settable from 0.6V to 5V
- Convenient power connection
- On-board enable switch
- Power-good indicator

Specifications

This board has been optimized as a buck regulator for the following operating conditions:

- V_{IN} = 12V
- V_{OUT} = 3.3V
- I_{MAX} = 6A (with airflow)
- f_{SW} = 400kHz
- Peak Efficiency: >85% at 50% Load
- Output Ripple: <0.5% at 6A
- Dynamic Response: 3.5%
(3A to 5A and 5A to 3A Steps, di/dt = 2.5A/μs)
- Board Temperature: +25 °C

Ordering Information

PART NUMBER	DESCRIPTION
ZL2106EVAL1Z	ZL2106 Evaluation board only, one channel

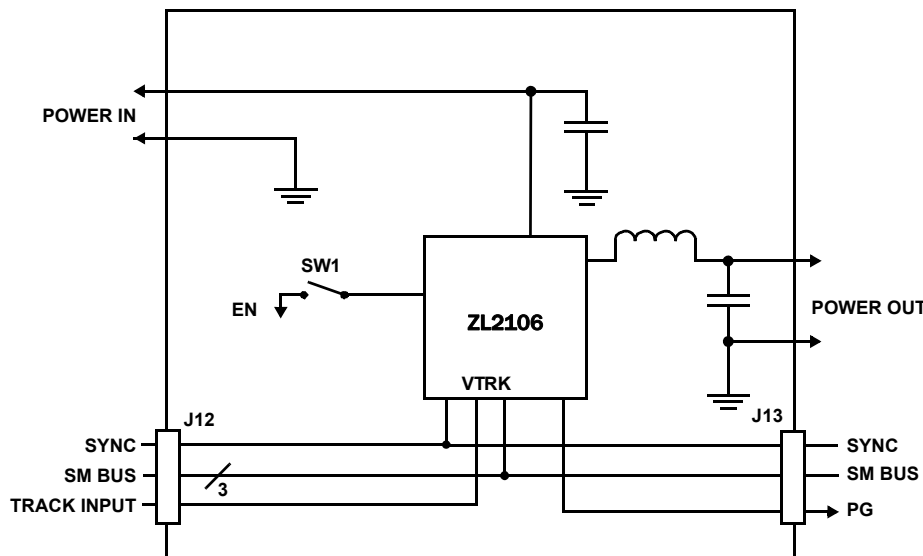

FIGURE 1. ZL2106EVAL1Z BLOCK DIAGRAM

Functional Description

The ZL2106EVAL1Z provides all circuitry required to demonstrate the features of the ZL2106. The ZL2106EVAL1Z has a functionality-optimized ZL2106 circuit layout that allows efficient operation up to the maximum output current. Power and load connections are provided through plug-in sockets.

Standalone operation is achieved using the pin-strap settings. The pin-strap setting details are described in the ZL2106 data sheet [FN6852](#).

The ZL2106 Evaluation Board is shown in Figure 2. The SMBus address is selectable through jumpers on the top side of the board. All power to the board (V_{IN} and I²C/SMBus bus) must be removed before changing the jumpers. The back side of the board has 0402 resistor footprints for setting the configuration pins using resistors.

The hardware enable function is controlled by a toggle switch on the ZL2106EVAL1Z board. The Power-Good (PG) LED is powered from the I²C/SMBus source; it indicates the correct state of PG when external power is applied to the ZL2106EVAL1Z board. The right angle headers at opposite ends of the board are for connecting a USB to I²C/SMBus control board or for daisy chaining of multiple evaluation boards. Figure 3 shows the ZL2106 application circuit. The circuit consists of the ZL2106 power conversion and management IC with its minimal component count to realize a buck converter. The board layout has been optimized for thermal performance.

Figure 4 shows the interface connections. Figure 5 illustrates the input and output power connections. The optional input capacitors and output capacitors are also shown in Table 1, which lists the complete bill of materials and is a recommended component list for the ZL2106.

The PCB has four layers and the layout for each layer is shown in Figure 6 to Figure 11. This is a recommended example layout for the ZL2106.

Operating Range

By default, the ZL2106EVAL1Z is configured for the operating conditions shown on page 1 using the bill of materials listed in Table 1 on page 8. The board can also support a wider operating range, and modifying the operating conditions will change the performance results.

The default board V_{OUT} range is 0.54V to 5.5V including margin. The output voltage can be changed by using the VSET resistor pad or by using a PMBus command. The board I_{OUT} range is 0A to 6A.

The board schematic in Figure 3 includes resistor population options for these connections.

The default switching frequency (f_{SW}) is 400kHz. The f_{SW} range is 200kHz to 1MHz. The PWM loop must maintain stability at the selected switching frequency, so the loop compensation PID settings may need to be modified when f_{SW} is changed. CompZL™ can be used to generate PID settings for different switching frequencies.

Board Operation

Stand-Alone Operation

The ZL2106 is easy to setup and operate. It is configured, out of the box, to provide 3.3V at 6A from a 12V source. All input and output connections should be made before turning on the input power supply.

When the input power supply is turned on, the ZL2106 will output the configured voltage and the load applied to V_{OUT+}/V_{OUT-} can be varied.

To modify the pin-strap setting of the ZL2106, input power must be turned off. The user adjustable pin-strap resistor pads are on the bottom side of the ZL2106EVAL1Z PCB. Once the desired pin-strap settings and component changes have been applied, power can be turned on and the output can be evaluated for the newly configured mode. Refer to the ZL2106 data sheet [FN6852](#) for pin-strap and resistor setting information. Refer to Figure 2 for resistor pad locations.

PMBus Operation

The ZL2106 utilizes the PMBus protocol. The PMBus functionality can be controlled via USB from a PC running the PowerNavigator evaluation software in a Windows XP or Windows 2000/NT operating system.

Install the ZL2106EVAL1Z software using the CD included in the ZL2106EVAL1Z kit.

For PMBus operation, connect another Zilker Labs evaluation board, such as the ZL2006EV2 or the USB-to-SMBus reference board, to J12 of the ZL2106EVAL1Z board. Connect the desired load and an appropriate power supply to the input. Place the ENABLE switch in “DISABLE” and turn on the power.

The PowerNavigator evaluation software allows modification of all ZL2106 PMBus parameters. Refer to Zilker Labs application note [AN2033](#) for PMBus command details. Use the mouse-over pop-ups for PowerNavigator help. Manually configure the ZL2106 through PowerNavigator or load a predefined scenario from a configuration file.

The ENABLE switch can then be moved to “ENABLE” and the ZL2106 can be tested. Alternately, the PMBus ON-OFF CONFIG and OPERATION commands may be used.

Loop Compensation Settings

These PID settings are included in the configuration file that is stored on the ZL2106 Evaluation Board, and is shown in “Default Configuration Text” on page 18 for reference. CompZL can be used to generate appropriate PID settings for other circuit configurations.

References

1. ZL2106 Data Sheet, 6A Digital-DC Synchronous Step-Down DC-DC Converter, File No. [FN6852](#).
2. Zilker Labs PMBus Command Set - DDC Products, [AN2033](#)

Quick Start Guide

Stand Alone Operation

1. Set ENABLE switch to "DISABLE"
2. Apply load to V_{OUT+}/V_{OUT-}
3. Connect input power supply to V_{IN+}/V_{IN-} (supply turned OFF)
4. Turn input power supply ON
5. Set ENABLE switch to "ENABLE"
6. Test ZL2106 operation
7. To change hardware settings, turn input power supply OFF, modify resistor settings and then turn the input power supply ON

USB (PMBus) Operation

1. Follow Steps 1 - 4 for stand alone operation
2. Insert the Zilker Labs Eval Kit CD
3. Connect USB-to-SMBus reference board to J12 of ZL2106EVAL1Z
4. Connect supplied USB cable from computer to USB-to-SMBus reference board
 - a. Upon first-time connection, the Found New Hardware Wizard will appear.
 - b. Windows XP users: Select 'No' at prompt to search the Internet for drivers.
 - c. Follow the steps on the screen to install the drivers from the CD.
5. Install the PowerNavigator evaluation software by running setup.exe from the PowerNavigator_installer folder on the CD.
6. Set voltage to desired value in GUI.
7. Set ENABLE switch on EVB to "ENABLE"
8. Monitor and configure EVB using PMBus commands in the evaluation software
9. Test ZL2106 operation using the evaluation software.

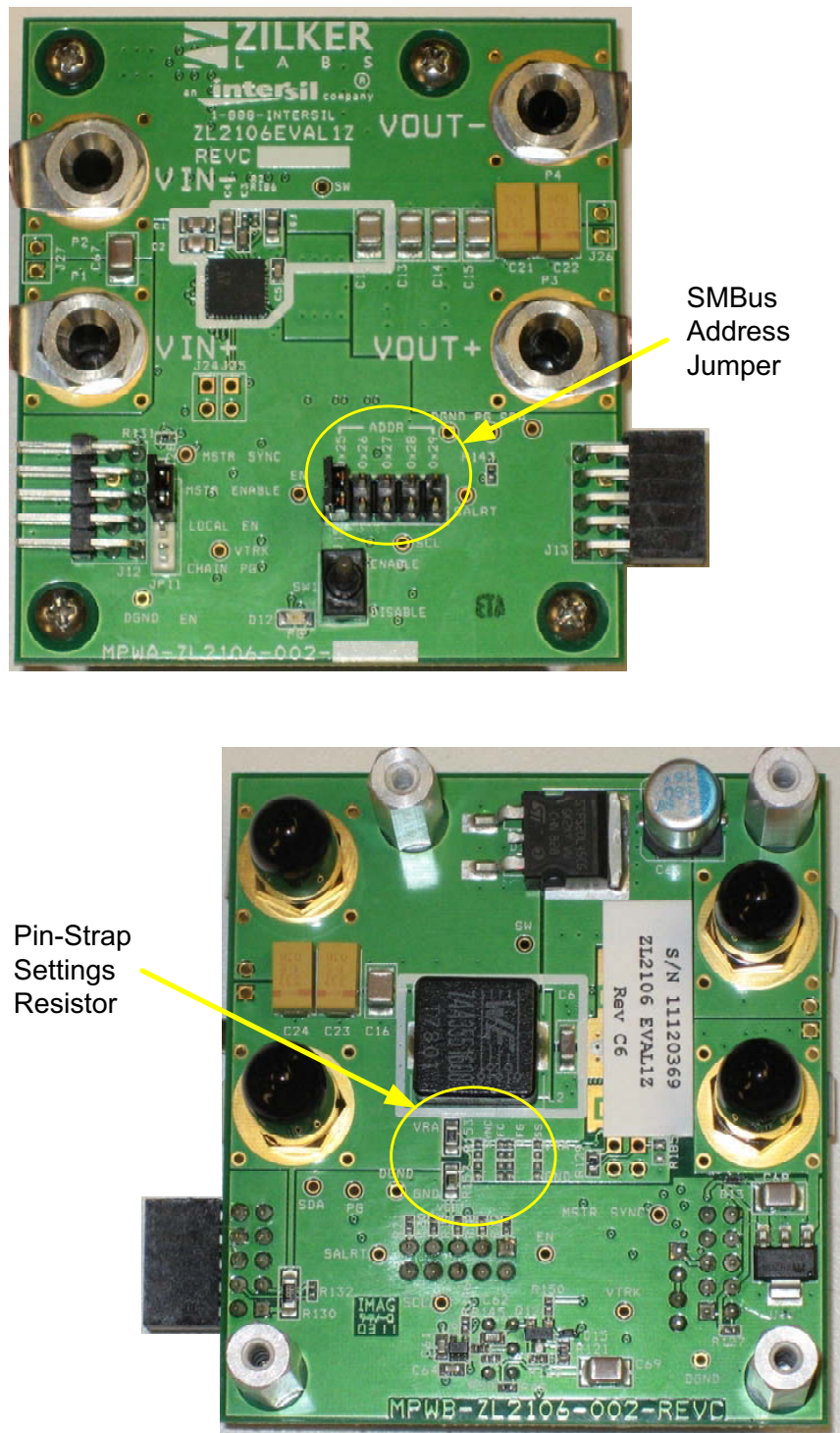

FIGURE 2. ZL2106EVAL1Z EVALUATION BOARD (TOP SIDE AND BOTTOM SIDE)

ZL2106EVAL1Z Schematics

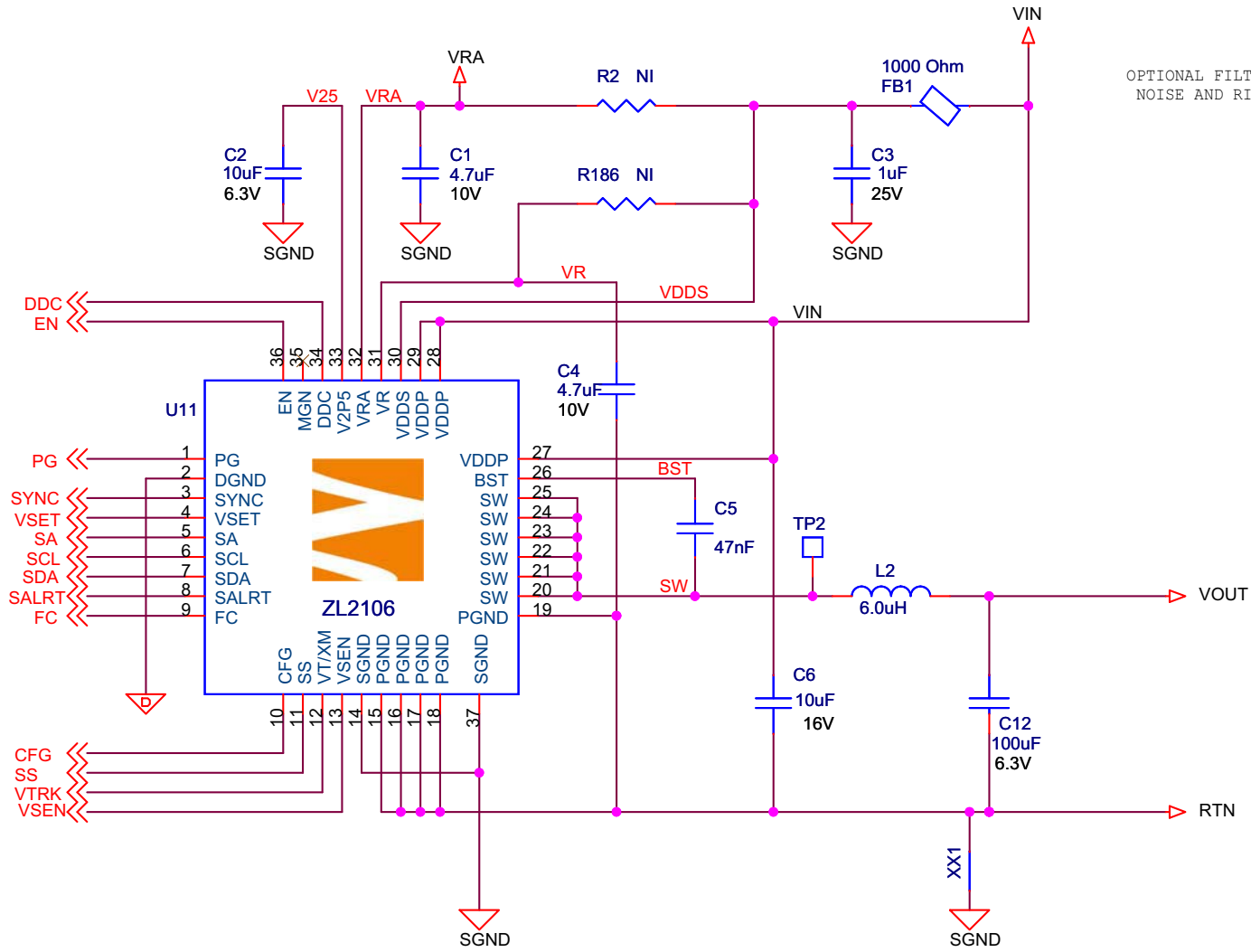

FIGURE 3. ZL2106EVAL1Z CIRCUIT

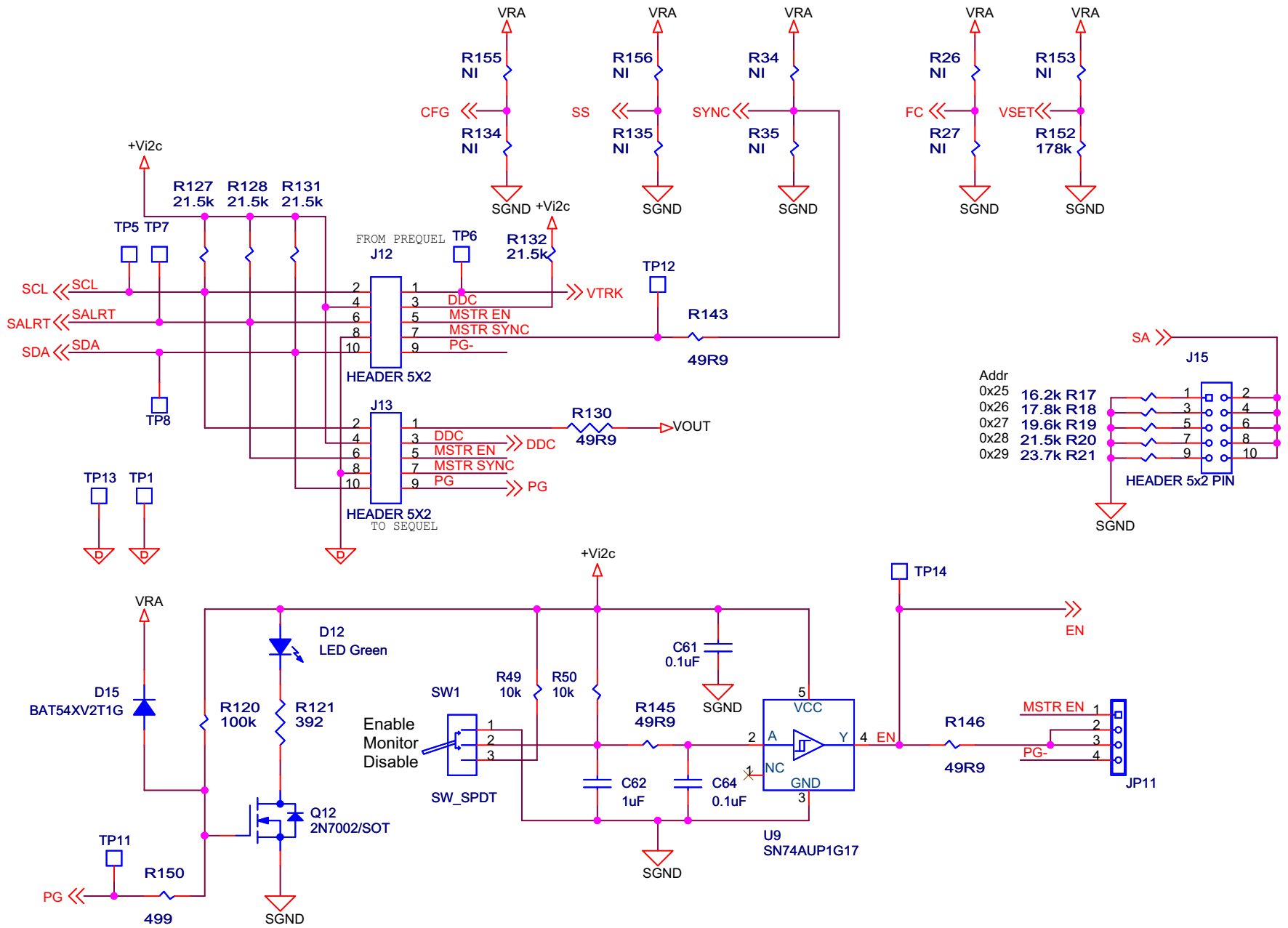
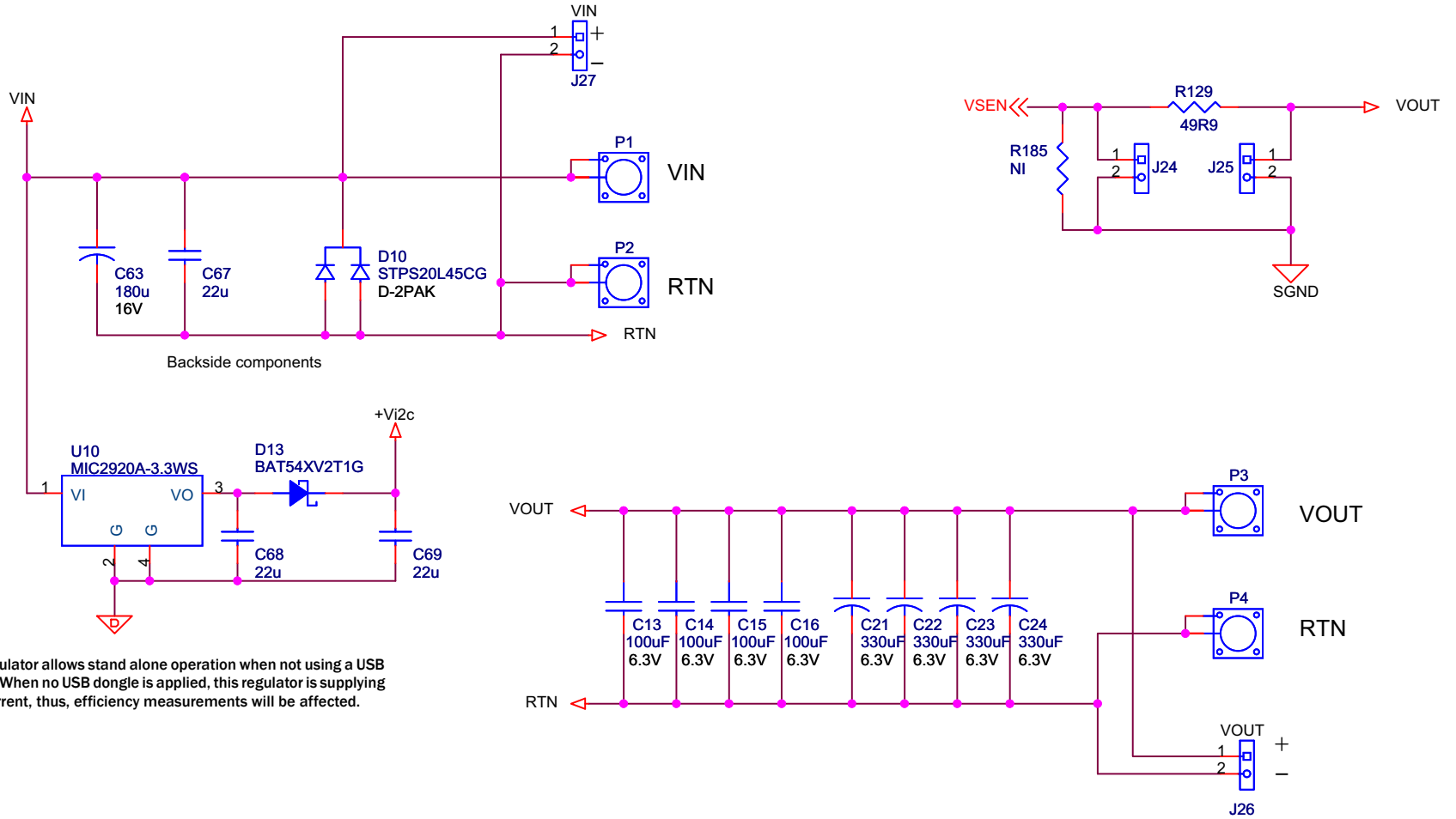

FIGURE 4. ZL2106EVAL1Z INTERFACE



This regulator allows stand alone operation when not using a USB dongle. When no USB dongle is applied, this regulator is supplying Vi2c current, thus, efficiency measurements will be affected.

FIGURE 5. ZL2106EVAL1Z POWER I/O

TABLE 1. BILL OF MATERIALS

PART NUMBER	QTY	REFERENCE DESIGNATOR	DESCRIPTION	MANUFACTURER	MANUFACTURER PART
ZL2106EVAL1ZREVCPCB	1		PWB-PCB, ZL2106EVAL1Z, REVC, ROHS	IMAGINEERING INC	ZL2106EVAL1ZREVCPCB
H1045-00104-16V10-T	2	C61, C64	CAP, SMD, 0603, 0.1 μ F, 16V, 10%, X7R, ROHS	MURATA	GRM39X7R104K016AD
H1045-00105-25V10-T	2	C3, C62	CAP, SMD, 0603, 1 μ F, 25V, 10%, X5R, ROHS	MURATA	GRM188R61E105KA12D
H1045-00473-25V10-T	1	C5	CAP, SMD, 0603, .047 μ F, 25V, 10%, X7R, ROHS	MURATA	GRM188R71E473KA01D
H1046-00106-10V10-T	1	C2	CAP, SMD, 0805, 10 μ F, 10V, 10%, X5R, ROHS	MURATA	GRM21BR61A106KE19L (Pb-Free)
H1046-00475-10V10-T	2	C1, C4	CAP, SMD, 0805, 4.7 μ F, 10V, 10%, X5R, ROHS	AVX	0805ZD475KAT2A
H1065-00106-16V10-T	1	C6	CAP, SMD, 1206, 10 μ F, 16V, 10%, X5R, ROHS	VENKEL	C1206X5R160-106KNE (Pb-Free)
H1082-00107-6R3V20-T	5	C12, C13, C14, C15, C16	CAP, SMD, 1210, 100 μ F, 6.3V, 20%, X5R, ROHS	TDK	C3225X5R0J107M
H1082-00226-16V10-T	3	C67, C68, C69	CAP, SMD, 1210, 22 μ F, 16V, 10%, X7R, ROHS	MURATA	GRM32ER71C226KE18L
T530Y337M006ATE006-T	4	C21, C22, C23, C24	CAP-TANT, LOW ESR, SMD, 7.3X4.3X4, 330 μ F, 6.3V, 20%, ROHS	KEMET	T530Y337M006ATE006
7443551600	1	L2	COIL-PWR INDUCTOR, SMD, 13.2X12.8, 6.0 μ H, 20%, 12A, ROHS	Wurth Electronics	7443551600
APXA160ARA181MHC0G-T	1	C63	CAP, SMD, 8X12, 180 μ F, 16V, 20%, 16M Ω , ALUM. ELEC., ROHS	NIPPON CHEMI-CON	APXA160ARA181MHC0G
108-0740-001	4	a) P1-P4 (4 each - attach solder lugs)	CONN-JACK, BANANA-SS-SDRLESS, VERTICAL, ROHS	JOHNSON COMPONENTS	108-0740-001
108-0740-001	0	b) Under jack head on top of PCB	CONN-JACK, BANANA-SS-SDRLESS, VERTICAL, ROHS	JOHNSON COMPONENTS	108-0740-001
108-0740-001	0	c) See "DOCUMENT #1"	CONN-JACK, BANANA-SS-SDRLESS, VERTICAL, ROHS	JOHNSON COMPONENTS	108-0740-001
3-644456-2	0	DNP-HS1, J24, J25, J26, J27	CONN-HEADER, 1X2, VERTICAL, 2.54mm, TIN, ROHS	TYCO ELECTRONICS	3-644456-2
3-644456-4	1	JP11	CONN-HEADER, 1X4, VERTICAL, TIN, WHT NYLON, ROHS	AMP/TYCO	3-644456-4
67996-272HLF-2X5	1	J15	CONN-HEADER, 2X5, BRKAWY-2X36, 2.54mm, ROHS	BERG/FCI	67996-272HLF
881545-2	2	J15 = Pin 1 and 2, JP11 = Pin 1 and 2	CONN-JUMPER, SHUNT LP W/HANDLE, 2P, 2.54mm, BLK, ROHS	TYCO ELECTRONICS	881545-2
SSQ-105-02-T-D-RA	1	J13	CONN-SOCKET STRIP, TH, 2X5, 2.54mm, TIN, R/A, ROHS	SAMTEC	SSQ-105-02-T-D-RA
TSW-105-08-T-D-RA	1	J12	CONN-HEADER, 2X5, BRKAWY, 2.54mm, TIN, R/A, ROHS	SAMTEC	TSW-105-08-T-D-RA
BAT54XV2T1G-T	2	D13, D15	DIODE-SCHOTTKY, SMD, 2P, SOD523, 30V, 200mA, ROHS	ON SEMICONDUCTOR	BAT54XV2T1G
STPS20L45CG	1	D10	DIODE-RECTIFIER, SCHOTTKY, SMD, D2PAK, 45V, 10A, ROHS	STMICROELECTRONICS	STPS20L45CG

TABLE 1. BILL OF MATERIALS (Continued)

PART NUMBER	QTY	REFERENCE DESIGNATOR	DESCRIPTION	MANUFACTURER	MANUFACTURER PART
CMD17-21VGC/TR8-T	1	D12	LED, SMD, 0805, GREEN, CLEAR, 10mcd, 2.1V, 20mA, 570nm, ROHS	CHICAGO MINIATURE	CMD17-21VGC/TR8
BLM21AG102SN1D-T	1	FB1	FERRITE CHIP, SMD, 0805, 1000Ω, 200mA, 100MHz, ROHS	MURATA	BLM21AG102SN1D
MIC2920A-3.3WS	1	U10	IC-LDO REGULATOR, 4P, SOT-223, 3.3V, 400mA, ROHS	MICREL	MIC2920A-3.3WS
SN74AUP1G17DCKR-T	1	U9	IC-BUFFER, SCHMITT TRIGGER, 5P, SC-70-5, 3.6V, 4mA, ROHS	TEXAS INSTRUMENTS	SN74AUP1G17DCKR
ZL2106ALCNT	1	U11	IC-6A DIGITAL-DC CONVERTER, 36P, QFN, 6X6, ROHS	INTERSIL	ZL2106ALCNT
2N7002-7-F-T	1	Q12	TRANSISTOR, N-CHANNEL, 3LD, SOT-23, 60V, 115mA, ROHS	DIODES, INC.	2N7002-7-F
H2510-00R00-1/16W-T	0	a) DNP - R2, R26, R27, R34, R35, R134, R135,	RES, SMD, 0402, 0Ω, 1/16W, 5%, TF, ROHS	VENKEL	CR0402-16W-00T
H2510-00R00-1/16W-T	0	b) DNP - R155, R156, R186	RES, SMD, 0402, 0Ω, 1/16W, 5%, TF, ROHS	VENKEL	CR0402-16W-00T
H2510-01002-1/16W1-T	2	R49, R50	RES, SMD, 0402, 10Ω, 1/16W, 1%, TF, ROHS	PANASONIC	ERJ-2RKF1002X
H2510-01003-1/16W1-T	1	R120	RES, SMD, 0402, 100Ω, 1/16W, 1%, TF, ROHS	PANASONIC	ERJ2RKF1003
H2510-01622-1/16W1-T	1	R17	RES, SMD, 0402, 16.2Ω, 1/16W, 1%, TF, ROHS	PANASONIC	ERJ-2RKF1622
H2510-01782-1/16W1-T	1	R18	RES, SMD, 0402, 17.8Ω, 1/16W, 1%, TF, ROHS	KOA	RK73H1ETTP1782F
H2510-01962-1/16W1-T	1	R19	RES, SMD, 0402, 19.6Ω, 1/16W, 1%, TF, ROHS	PANASONIC	ERJ-2RKF1962
H2510-02152-1/16W1-T	5	R20, R127, R128, R131, R132	RES, SMD, 0402, 21.5Ω, 1/16W, 1%, TF, ROHS	PANASONIC	ERJ-2RKF2152X
H2510-02372-1/16W1-T	1	R21	RES, SMD, 0402, 23.7Ω, 1/16W, 1%, TF, ROHS	PANASONIC	ERJ-2RKF2372X
H2510-04990-1/16W1-T	1	R150	RES, SMD, 0402, 499Ω, 1/16W, 1%, TF, ROHS	VENKEL	CR0402-16W-4990FT
H2510-049R9-1/16W1-T	3	R143, R145, R146	RES, SMD, 0402, 49.9Ω, 1/16W, 1%, TF, ROHS	PANASONIC	ERJ-2RKF49R9X
H2511-03920-1/10W1-T	1	R121	RES, SMD, 0603, 392Ω, 1/10W, 1%, TF, ROHS	PANASONIC	ERJ-3EKF3920V
H2511-049R9-1/10W1-T	1	R129	RES, SMD, 0603, 49.9Ω, 1/10W, 1%, TF, ROHS	VENKEL	CR0603-10W-49R9FT
H2511-DNP	0	R185	RES, SMD, 0603, DNP-PLACE HOLDER, ROHS		
H2512-00R00-1/8W-T	1	R153	RES, SMD, 0805, 0Ω, 1/8W, TF, ROHS	YAGEO	RC0805JR-070RL
H2512-01783-1/8W1-T	1	R152	RES, SMD, 0805, 178Ω, 1/8W, 1%, TF, ROHS	VENKEL	CR0805-8W-1783FT
H2513-049R9-1/4W1-T	1	R130	RES, SMD, 1206, 49.9Ω, 1/4W, 1%, TF, ROHS	VISHAY/DALE	CRCW120649R9FKEA
G13AP-RO	1	SW1	SWITCH-TOGGLE, THRU-HOLE, 5P, SPDT, 3POS, ON-OFF-ON, ROHS	NKK	G13AP-RO
172-1024-E	1	Bag & ship w/board.	CABLE-USB 2.0, TYPE A MALE TO TYPE B MALE, 2M, ROHS	KOBICONN	172-1024-E
ZLUSBEVAL1ZFG	1	Bag & ship w/board.	PWB-FG, ZLUSBEVAL1Z, ROHS	INTERSIL	ZLUSBEVAL1ZFG
4-40X1/4-SCREW-SS	4	Four corners	SCREW, 4-40X1/4in, PHILLIPS, PAN, STAINLESS STEEL, ROHS	KEYSTONE	9900

TABLE 1. BILL OF MATERIALS (Continued)

PART NUMBER	QTY	REFERENCE DESIGNATOR	DESCRIPTION	MANUFACTURER	MANUFACTURER PART
4-40X3/4-STANDOFF-SS	4	Four corners	STANDOFF, 4-40X3/4in, F/F, HEX, STAINLESS STEEL, ROHS	KEystone	1921C
5X8-STATIC-BAG	1	Place assy in bag	BAG, STATIC, 5X8, ZIPLOC, ROHS	INTERSIL	212403-013
DOCUMENT #1	1	Banana jack instructions	See attached document for manual or visual instruction	INTERSIL	DOCUMENT #1
INTERSIL-ZILKER_CD1	1	Bag & ship w/board	CD-SOFTWARE, INTERSIL-ZILKER_CD1	INTERSIL	INTERSIL-ZILKER_CD1
Label-serial number	1		Label, for serial number and BOM rev #		
VC-234-8	4	P1, P2, P3, P4	CAPLUG-ROUND VINYL CLOSURE, FLEXIBLE, 0.5X0.234, ROHS	CAPLUGS	VC-234-8

ZL2106EVAL1Z Board Layout - 6 Layers

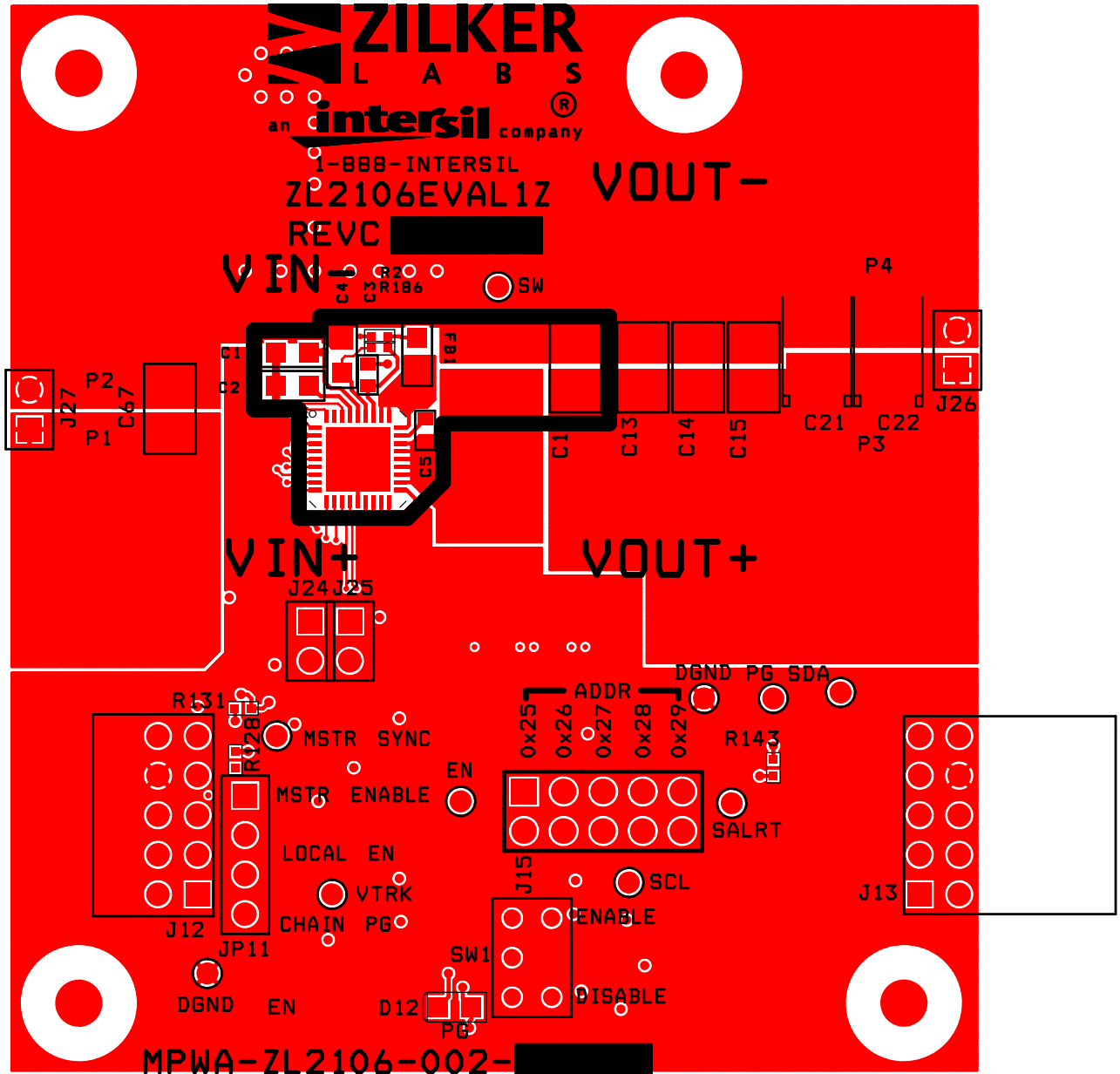

FIGURE 6. TOP LAYER

NOTE: TP2 is labeled SW but is connected to BST (see Figure 3 schematic).

ZL2106EVAL1Z Board Layout - 6 Layers (Continued)

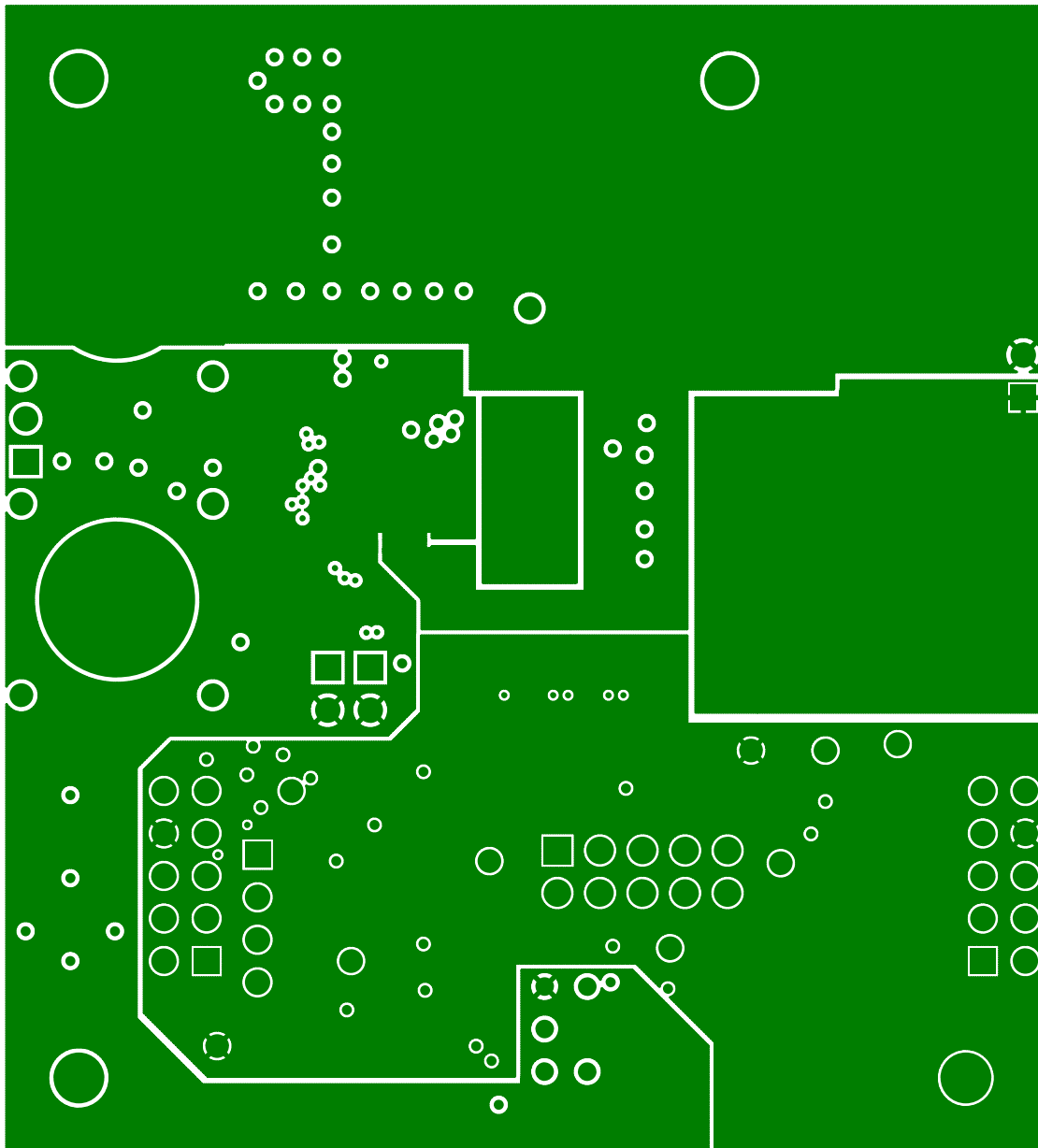

FIGURE 7. PCB - INNER LAYER 1 (VIEWED FROM TOP)

ZL2106EVAL1Z Board Layout - 6 Layers (Continued)

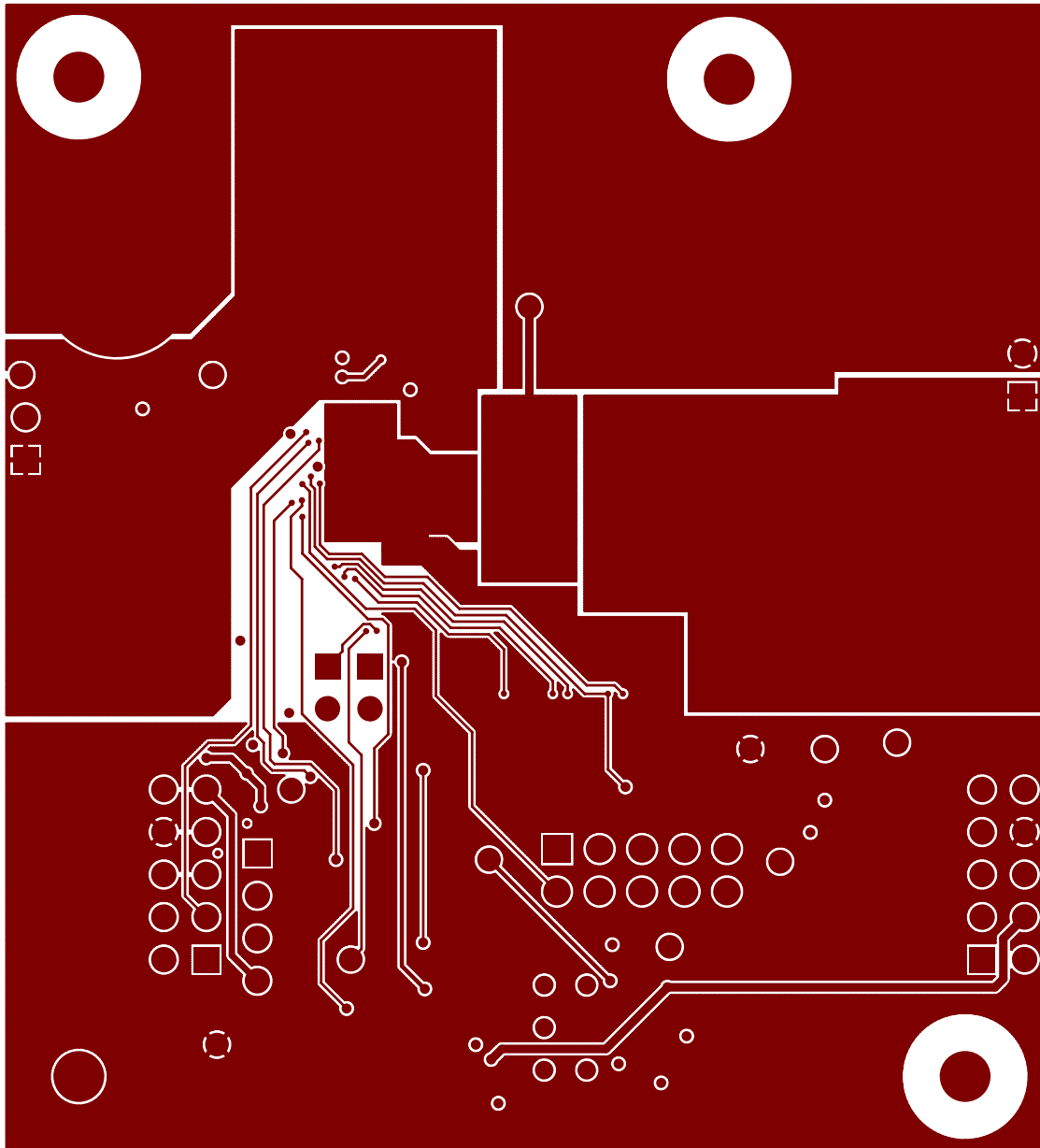

FIGURE 8. PCB - INNER LAYER 2 (VIEWED FROM TOP)

ZL2106EVAL1Z Board Layout - 6 Layers (Continued)

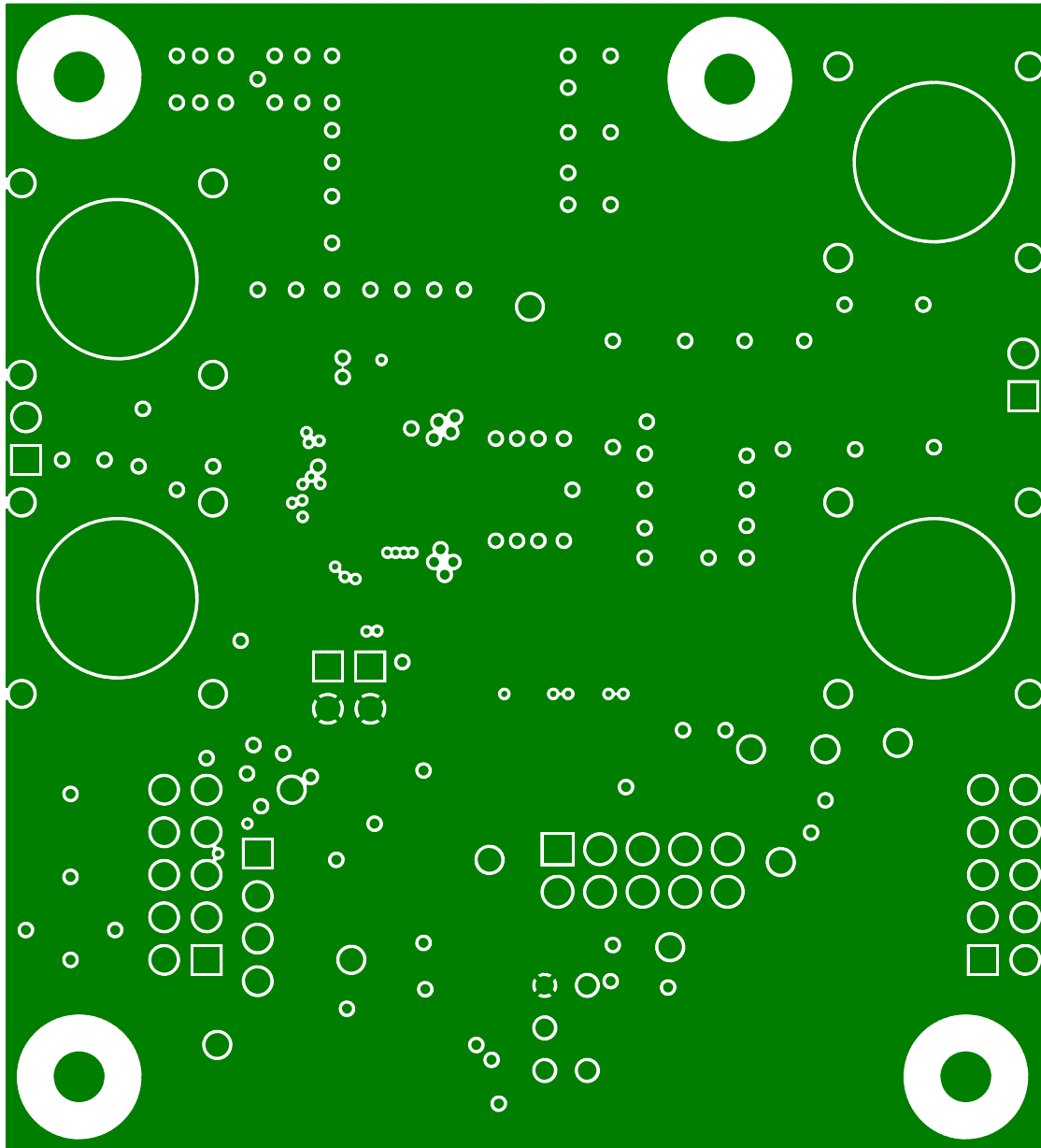

FIGURE 9. PCB - INNER LAYER 3 (VIEWED FROM TOP)

ZL2106EVAL1Z Board Layout - 6 Layers (Continued)

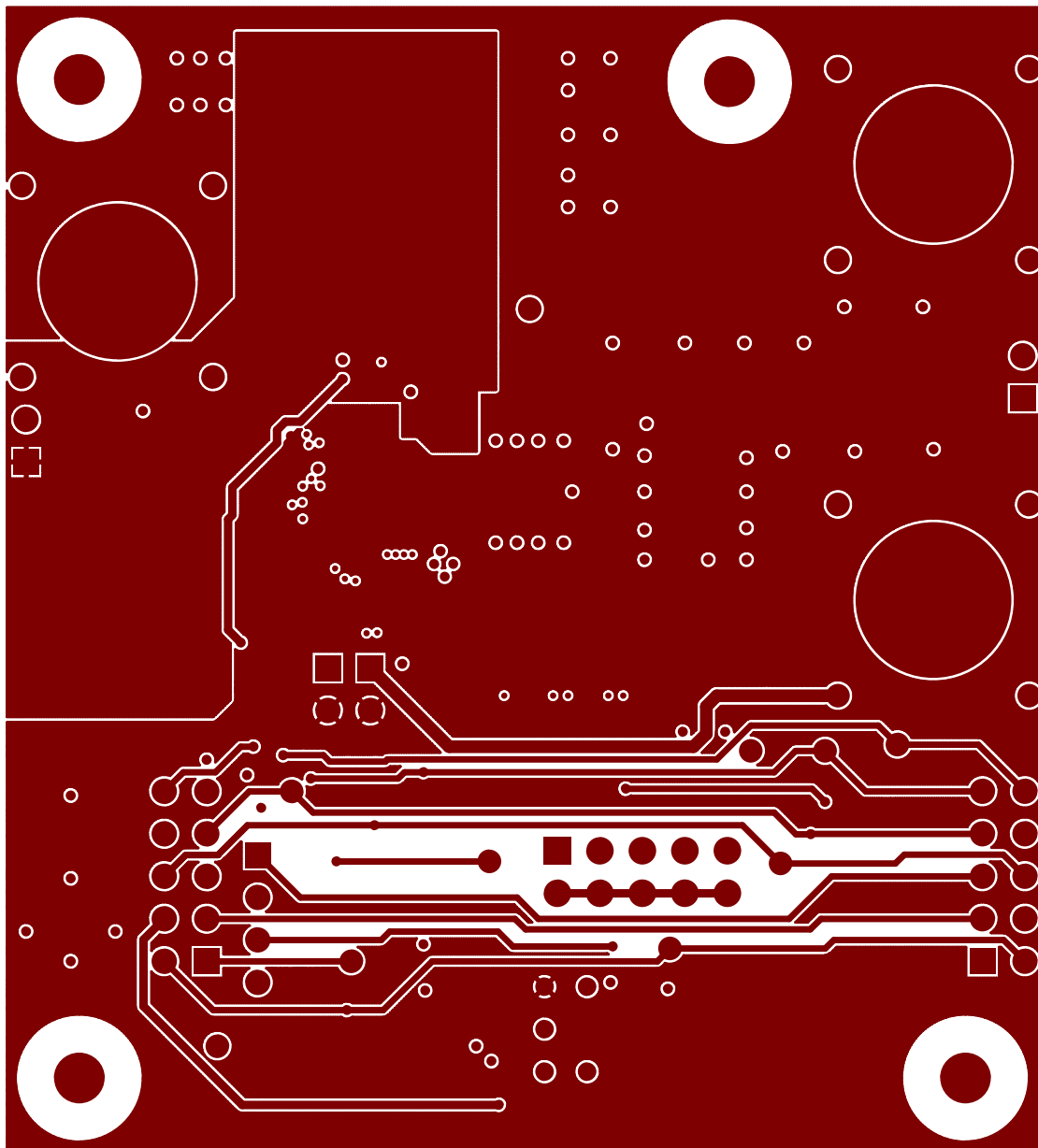

FIGURE 10. PCB - INNER LAYER 4 (VIEWED FROM TOP)

ZL2106EVAL1Z Board Layout - 6 Layers (Continued)

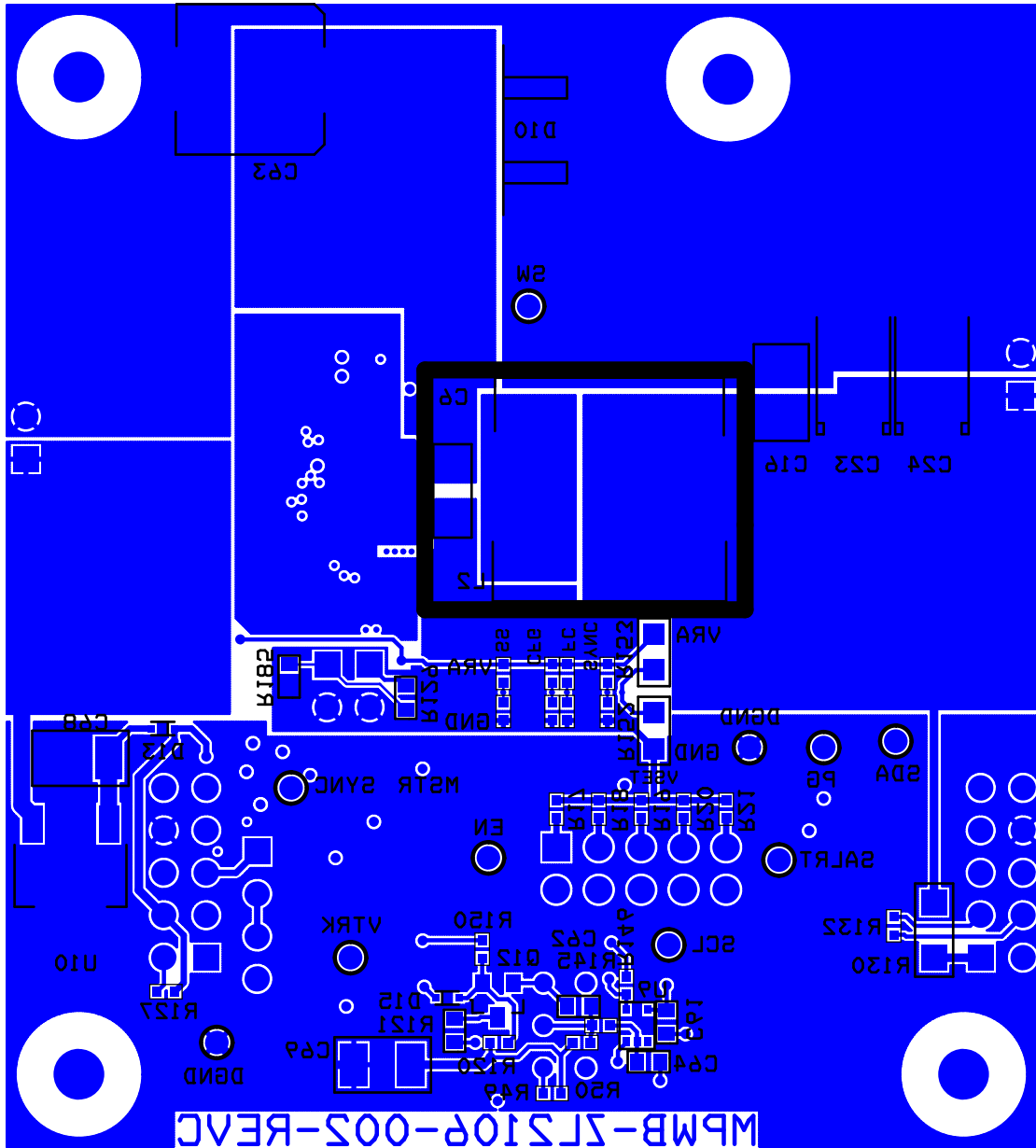

FIGURE 11. PCB - BOTTOM LAYER (VIEWED FROM TOP)

Typical Performance Curves for ZL2106 Buck Regulator

Unless noted: $V_{IN} = 12V$, $V_{OUT} = 3.3V$, $f_{SW} = 400kHz$, $T_A = +25^\circ C$

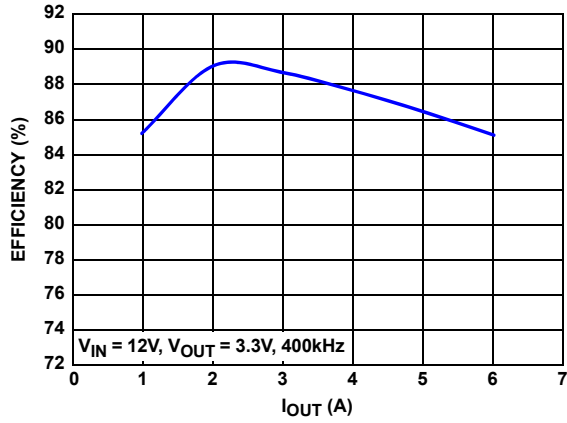

FIGURE 12. MEASURED EFFICIENCY

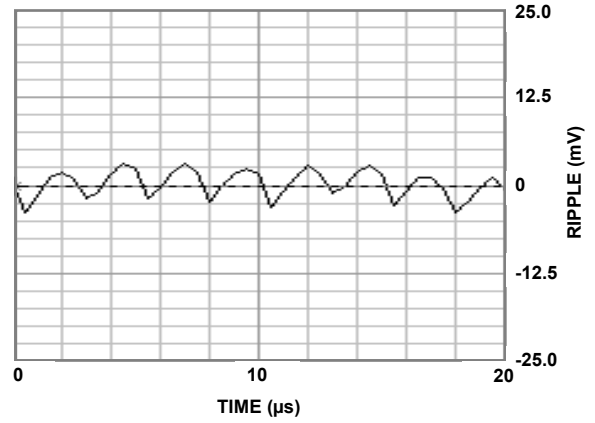

FIGURE 13. OUTPUT RIPPLE

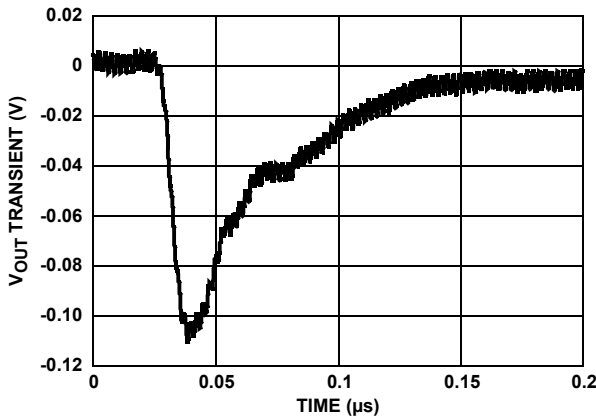

FIGURE 14. DYNAMIC RESPONSE (3A TO 5A LOAD STEP, $di/dt = 2.5A/\mu s$)

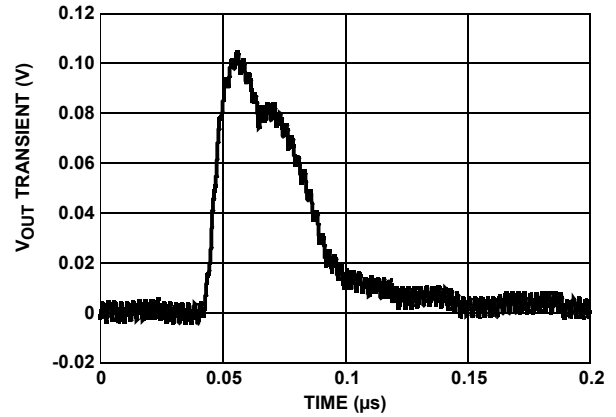

FIGURE 15. DYNAMIC RESPONSE (5A TO 3A LOAD STEP, $di/dt = 2.5A/\mu s$)

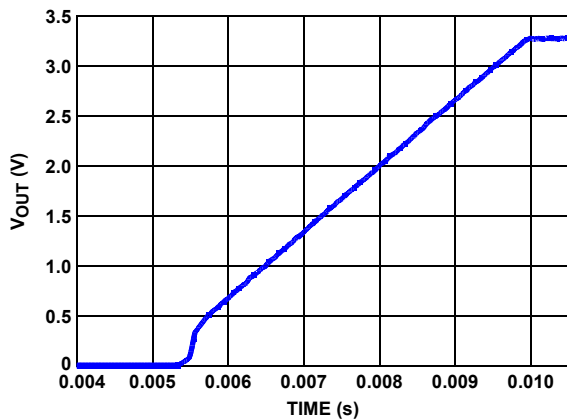

FIGURE 16. RAMP-UP TIME

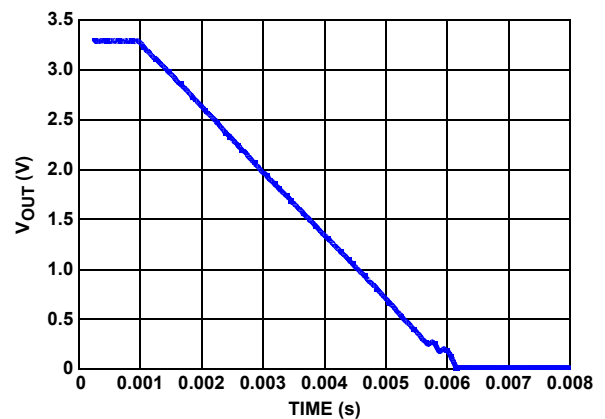

FIGURE 17. RAMP-DOWN TIME

Default Configuration Text

The following configuration text is loaded into the ZL2106EVAL1Z as default settings. Each PMBus command is loaded via the PowerNavigator software. The # symbol is used for a comment line.

```
#Configuration file for ZL2106
RESTORE_FACTORY
STORE_DEFAULT_ALL
STORE_USER_ALL
RESTORE_DEFAULT_ALL

MFR_ID Zilker_Labs
MFR_MODEL ZL2106_EVAL1Z
MFR_REVISION 1.7
MFR_LOCATION Austin_TX

FREQUENCY_SWITCH 400 # kHz

VOUT_COMMAND 3.3

POWER_GOOD_DELAY 1

VOUT_OV_FAULT_RESPONSE 0x80
VOUT_UV_FAULT_RESPONSE 0x80
OVUV_CONFIG 0x80
VIN_OV_FAULT_RESPONSE 0x80
VIN_UV_FAULT_RESPONSE 0x80

TON_DELAY 5
TON_RISE 10
TOFF_DELAY 5
TOFF_FALL 10

IOUT_OC_FAULT_LIMIT 10
IOUT_AVG_OC_FAULT_LIMIT 10
IOUT_UC_FAULT_LIMIT -4.0
IOUT_AVG_UC_FAULT_LIMIT -3.5

MFR_IOUT_OC_FAULT_RESPONSE 0x80
MFR_IOUT_UC_FAULT_RESPONSE 0x80

OT_FAULT_RESPONSE 0xBF
UT_FAULT_RESPONSE 0xBF

#MFR_CONFIG 0x4200
USER_CONFIG 0x2000
MISC_CONFIG 0x0080
#DDC_CONFIG 0x0000

INDUCTOR 6.0

PID_TAPS A=21237.00, B=-37086.00, C=15871.00
#PID_TAPS A=23303.50, B=-44911.00, C=21628.00

STORE_DEFAULT_ALL
RESTORE_DEFAULT_ALL
```

Notice

1. Descriptions of circuits, software and other related information in this document are provided only to illustrate the operation of semiconductor products and application examples. You are fully responsible for the incorporation or any other use of the circuits, software, and information in the design of your product or system. Renesas Electronics disclaims any and all liability for any losses and damages incurred by you or third parties arising from the use of these circuits, software, or information.
2. Renesas Electronics hereby expressly disclaims any warranties against and liability for infringement or any other claims involving patents, copyrights, or other intellectual property rights of third parties, by or arising from the use of Renesas Electronics products or technical information described in this document, including but not limited to, the product data, drawings, charts, programs, algorithms, and application examples.
3. No license, express, implied or otherwise, is granted hereby under any patents, copyrights or other intellectual property rights of Renesas Electronics or others.
4. You shall not alter, modify, copy, or reverse engineer any Renesas Electronics product, whether in whole or in part. Renesas Electronics disclaims any and all liability for any losses or damages incurred by you or third parties arising from such alteration, modification, copying or reverse engineering.
5. Renesas Electronics products are classified according to the following two quality grades: "Standard" and "High Quality". The intended applications for each Renesas Electronics product depends on the product's quality grade, as indicated below.
"Standard": Computers; office equipment; communications equipment; test and measurement equipment; audio and visual equipment; home electronic appliances; machine tools; personal electronic equipment; industrial robots; etc.
"High Quality": Transportation equipment (automobiles, trains, ships, etc.); traffic control (traffic lights); large-scale communication equipment; key financial terminal systems; safety control equipment; etc.
Unless expressly designated as a high reliability product or a product for harsh environments in a Renesas Electronics data sheet or other Renesas Electronics document, Renesas Electronics products are not intended or authorized for use in products or systems that may pose a direct threat to human life or bodily injury (artificial life support devices or systems; surgical implantations; etc.), or may cause serious property damage (space system; undersea repeaters; nuclear power control systems; aircraft control systems; key plant systems; military equipment; etc.). Renesas Electronics disclaims any and all liability for any damages or losses incurred by you or any third parties arising from the use of any Renesas Electronics product that is inconsistent with any Renesas Electronics data sheet, user's manual or other Renesas Electronics document.
6. When using Renesas Electronics products, refer to the latest product information (data sheets, user's manuals, application notes, "General Notes for Handling and Using Semiconductor Devices" in the reliability handbook, etc.), and ensure that usage conditions are within the ranges specified by Renesas Electronics with respect to maximum ratings, operating power supply voltage range, heat dissipation characteristics, installation, etc. Renesas Electronics disclaims any and all liability for any malfunctions, failure or accident arising out of the use of Renesas Electronics products outside of such specified ranges.
7. Although Renesas Electronics endeavors to improve the quality and reliability of Renesas Electronics products, semiconductor products have specific characteristics, such as the occurrence of failure at a certain rate and malfunctions under certain use conditions. Unless designated as a high reliability product or a product for harsh environments in a Renesas Electronics data sheet or other Renesas Electronics document, Renesas Electronics products are not subject to radiation resistance design. You are responsible for implementing safety measures to guard against the possibility of bodily injury, injury or damage caused by fire, and/or danger to the public in the event of a failure or malfunction of Renesas Electronics products, such as safety design for hardware and software, including but not limited to redundancy, fire control and malfunction prevention, appropriate treatment for aging degradation or any other appropriate measures. Because the evaluation of microcomputer software alone is very difficult and impractical, you are responsible for evaluating the safety of the final products or systems manufactured by you.
8. Please contact a Renesas Electronics sales office for details as to environmental matters such as the environmental compatibility of each Renesas Electronics product. You are responsible for carefully and sufficiently investigating applicable laws and regulations that regulate the inclusion or use of controlled substances, including without limitation, the EU RoHS Directive, and using Renesas Electronics products in compliance with all these applicable laws and regulations. Renesas Electronics disclaims any and all liability for damages or losses occurring as a result of your noncompliance with applicable laws and regulations.
9. Renesas Electronics products and technologies shall not be used for or incorporated into any products or systems whose manufacture, use, or sale is prohibited under any applicable domestic or foreign laws or regulations. You shall comply with any applicable export control laws and regulations promulgated and administered by the governments of any countries asserting jurisdiction over the parties or transactions.
10. It is the responsibility of the buyer or distributor of Renesas Electronics products, or any other party who distributes, disposes of, or otherwise sells or transfers the product to a third party, to notify such third party in advance of the contents and conditions set forth in this document.
11. This document shall not be reprinted, reproduced or duplicated in any form, in whole or in part, without prior written consent of Renesas Electronics.
12. Please contact a Renesas Electronics sales office if you have any questions regarding the information contained in this document or Renesas Electronics products.
(Note 1) "Renesas Electronics" as used in this document means Renesas Electronics Corporation and also includes its directly or indirectly controlled subsidiaries.
(Note 2) "Renesas Electronics product(s)" means any product developed or manufactured by or for Renesas Electronics.

(Rev.4.0-1 November 2017)



SALES OFFICES

Renesas Electronics Corporation

<http://www.renesas.com>

Refer to "<http://www.renesas.com/>" for the latest and detailed information.

Renesas Electronics America Inc.
1001 Murphy Ranch Road, Milpitas, CA 95035, U.S.A.
Tel: +1-408-432-8888, Fax: +1-408-434-5351

Renesas Electronics Canada Limited
9251 Yonge Street, Suite 8309 Richmond Hill, Ontario Canada L4C 9T3
Tel: +1-905-237-2004

Renesas Electronics Europe Limited
Dukes Meadow, Millboard Road, Bourne End, Buckinghamshire, SL8 5FH, U.K.
Tel: +44-1628-651-700, Fax: +44-1628-651-804

Renesas Electronics Europe GmbH
Arcadiastrasse 10, 40472 Düsseldorf, Germany
Tel: +49-211-6503-0, Fax: +49-211-6503-1327

Renesas Electronics (China) Co., Ltd.
Room 1709 Quantum Plaza, No.27 ZhichunLu, Haidian District, Beijing, 100191 P. R. China
Tel: +86-10-8235-1155, Fax: +86-10-8235-7679

Renesas Electronics (Shanghai) Co., Ltd.
Unit 301, Tower A, Central Towers, 555 Langao Road, Putuo District, Shanghai, 200333 P. R. China
Tel: +86-21-2226-0888, Fax: +86-21-2226-0999

Renesas Electronics Hong Kong Limited
Unit 1601-1611, 16/F., Tower 2, Grand Century Place, 193 Prince Edward Road West, Mongkok, Kowloon, Hong Kong
Tel: +852-2265-6688, Fax: +852-2886-9022

Renesas Electronics Taiwan Co., Ltd.
13F, No. 363, Fu Shing North Road, Taipei 10543, Taiwan
Tel: +886-2-8175-9600, Fax: +886-2-8175-9670

Renesas Electronics Singapore Pte. Ltd.
80 Bendemeer Road, Unit #06-02 Hyflux Innovation Centre, Singapore 339949
Tel: +65-6213-0200, Fax: +65-6213-0300

Renesas Electronics Malaysia Sdn.Bhd.
Unit 1207, Block B, Menara Amcorp, Amcorp Trade Centre, No. 18, Jln Persiaran Barat, 46050 Petaling Jaya, Selangor Darul Ehsan, Malaysia
Tel: +60-3-7955-9390, Fax: +60-3-7955-9510

Renesas Electronics India Pvt. Ltd.
No.777C, 100 Feet Road, HAL 2nd Stage, Indiranagar, Bangalore 560 038, India
Tel: +91-80-67208700, Fax: +91-80-67208777

Renesas Electronics Korea Co., Ltd.
17F, KAMCO Yangjae Tower, 262, Gangnam-daero, Gangnam-gu, Seoul, 06265 Korea
Tel: +82-2-558-3737, Fax: +82-2-558-5338