

## CCE4510 Evaluation Board V3

4-Channel IO-Link Master

The CCE4510 Evaluation Board is designed to evaluate the CCE4510 IO-Link Master IC with integrated Frame Handler

### Feature Overview

- 32-Bit RXv2 Microcontroller (RX231)
- On-Board 3.3 V LDO
- 16 kB EEPROM
- Programmable via USB, SCI or FINE interface
- Status LED indicator
- External NMOS gate drivers
- 24 V supply voltage
- Two CCE4510 IO-Link Master Transceiver ICs
- Four IO-Link channels
- Four Status LED indicators for IO-Link channels
- Additional on-board protection circuitry
- All pins accessible via pin-headers for microcontroller and IO-Link Master ICs
- Independent use of sections
- Demonstration stack from TMG TE available

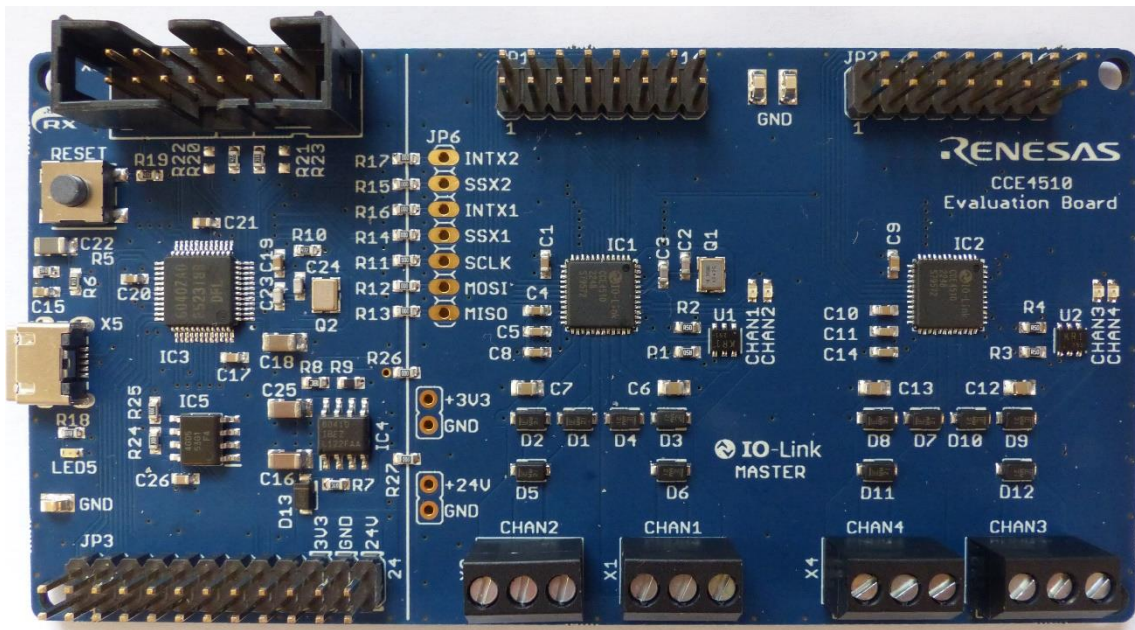

Figure 1. CCE4510 Evaluation Board V3

## Contents

<b>1. References</b> .....	<b>3</b>
<b>2. Introduction</b> .....	<b>3</b>
<b>3. System Requirements</b> .....	<b>4</b>
<b>4. Getting Started</b> .....	<b>5</b>
4.1 Erase Pre-Installed IO-Link Master Demonstration Stack.....	5
4.2 Use Pre-Installed IO-Link Master Demonstration Stack or Start Evaluation.....	6
<b>5. Sections</b> .....	<b>7</b>
5.1 IO-Link Section.....	7
5.2 MCU Section.....	7
<b>6. Schematic and Layout</b> .....	<b>8</b>
6.1 Connectors.....	8
6.2 Schematic.....	9
6.3 Bill of Materials.....	11
6.4 Board Layout.....	13
<b>7. Ordering Information</b> .....	<b>15</b>
<b>8. Glossary</b> .....	<b>15</b>
<b>9. Revision History</b> .....	<b>15</b>

## Figures

Figure 1. CCE4510 Evaluation Board V3.....	1
Figure 3. System Diagram.....	3
Figure 4. Sections Overview.....	7
Figure 5. Connectors.....	8
Figure 6. Schematics 1.....	9
Figure 7. Schematics 2.....	10
Figure 8. Top Layer.....	13
Figure 9. Second Layer (GND).....	13
Figure 10. Third Layer (Supply).....	14
Figure 11. Bottom Layer.....	14

## 1. References

- CCE4510 Datasheet, Renesas Electronics
- RX231 Group Datasheet, Renesas Electronics
- RX231 Group User's Manual: Hardware, Renesas Electronics
- ISL80410IBEZ-T Datasheet, Renesas Electronics
- R1EX24128BSAS0 Datasheet, Renesas Electronics
- IO-Link Interface and System Specification V1.1.3, IO-Link Community

## 2. Introduction

The CCE4510 Evaluation Board can be used in three ways:

1. Evaluate the CCE4510 with the on-board MCU
2. Evaluate the CCE4510 using any suitable external MCU
3. Demonstration with pre-installed IO-Link Stack from TMG TE ([www.tmgte.de/en](http://www.tmgte.de/en))

The board is divided into two sections:

- IO-Link Section
  - The IO-Link section contains two CCE4510 including all necessary periphery to use the two CCE4510 for IO-Link communication.
- MCU Section
  - The MCU section contains a RX231 32-bit RXv2 microcontroller from Renesas to control the CCE4510 Master ICs and a 16kB EEPROM. An LDO with 3.3 V output voltage supplies both sections.

For maximum flexibility, the sections can be used separately and independently from each other. This allows to evaluate the CCE4510 Master IC with every suitable MCU.

The evaluation board is compliant to IO-Link Interface and System Specification V1.1.3

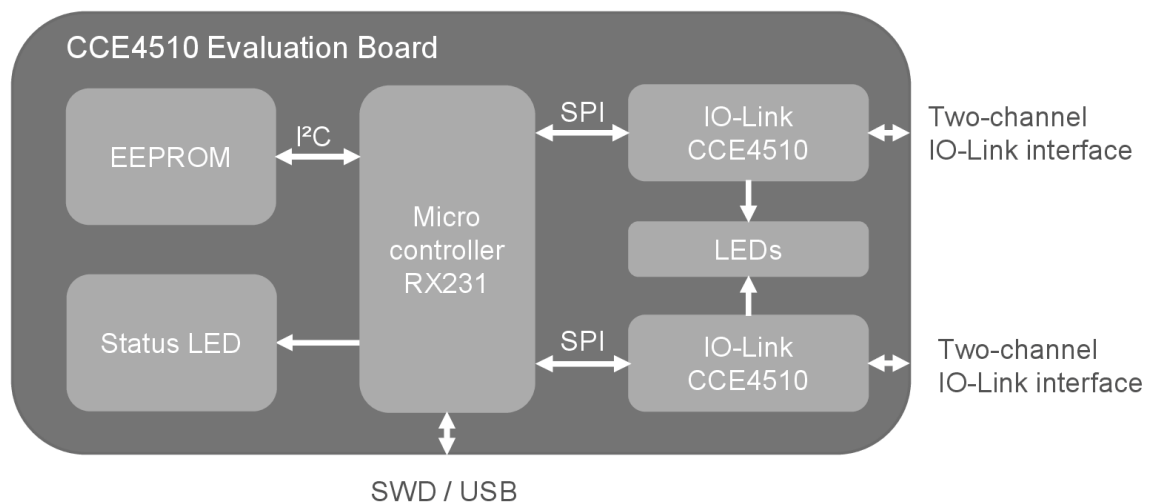

Figure 2. System Diagram

### 3. System Requirements

The CCE4510 evaluation board is ready to use with a pre-installed IO-Link demonstration master stack or can be used for evaluation using custom code.

To get started, the following tools are required:

#### For Evaluation with on-board MCU

- 24 V Power Supply
- USB Cable (Micro USB type B)
- Debug probe (for programming via SCI or FINE interface), for example Renesas E2 or E2lite Emulator
- IDE and Coding tool, for example Renesas e<sup>2</sup> Studio, downloadable at [www.Renesas.com](http://www.Renesas.com)

#### For Evaluation with any suitable external MCU

- External MCU
- 24 V Power Supply
- Connection cable to connect external MCU to JP1, JP2, JP5 and JP6 (for SPI connection, only JP5 and JP6 are necessary)
- IDE and Coding tool

#### For demonstration using the pre-installed IO-Link master stack

- 24 V Power Supply
- USB Cable (Micro USB type B)
- TMG TE IO-Link Device Tool V5.1.1-7475 PE or higher, downloadable at [www.tmgte.de/en](http://www.tmgte.de/en)  
(A license is required after 30 days and can be requested from TMG)
- IO-Link Master description (IOLM), downloadable at [www.Renesas.com](http://www.Renesas.com)

## 4. Getting Started

### 4.1 Erase Pre-Installed IO-Link Master Demonstration Stack

The pre-installed IO-Link demonstration master stack comes with a code protection. This prevents any attempt to read, write or debug the board.

To erase the flash and enable the write, read and debug of the board again, the following steps need to be taken:

#### Erase Flash using Debug probe (for example E2 / E2 lite)

1. Connect the debug probe (X6) to the board
2. Connect the 24 V Power Supply (JP3)
3. Power on 24 V Power Supply
4. Use the Renesas Flash Programmer (RFP) and set up a new project. When clicking "Connect", a request for an authentication code will show.
5. Click "OK" three times consecutively, then click "cancel". This will erase the flash due to 3 failed attempts of entering the correct authentication code.
6. Click "Connect" again to establish the communication. The board is now ready for programming or debugging.

#### Erase Flash using USB

1. Connect the USB to the board (X5)
2. Pull MD low & UB high (JP3) to get into the USB Boot Mode
3. Connect the 24 V Power Supply (JP3)
4. Power on 24 V Power Supply (The board should now be recognized as "Generic Boot USB Direct" under the "Renesas USB Development Tools" tab of the PC's Device Manager.)
5. Use the Renesas Flash Programmer (RFP) and set up a new project using "USB direct" as tool. When clicking "Connect", a request for an authentication code will show.
6. Click "OK" three times consecutively, then click "cancel". This will erase the flash due to 3 failed attempts of entering the correct authentication code.
7. Click the "RESET" switch of the board.
8. Click "Connect" again to establish the communication. The board is now ready for programming or debugging.
9. Optional: if you directly want to flash the board again, click the "RESET" button once again and flash the board with the desired file.

**PLEASE NOTE: If the IO-Link demonstration master stack needs to be reinstalled, the stack needs to be requested from our software partner TMG TE.**

## 4.2 Use Pre-Installed IO-Link Master Demonstration Stack or Start Evaluation

To get started with the pre-installed IO-Link demonstration master stack or with the evaluation of the board using the on Board MCU or an external MCU, the following steps need to be taken:

### For Evaluation with on board MCU (programming via SCI or FINE)

1. Connect the debug probe to the board (X6)
2. Connect the 24 V Power Supply (JP3)
3. Power on 24 V Power Supply
4. Start programming with your preferred IDE

### For Evaluation with on board MCU (programming via USB)

1. Pull MD low and UB high (JP3) to get into the USB Boot Mode
2. Connect the USB cable to the board (X5)
3. Connect the 24 V Power Supply (JP3)
4. Power on 24 V Power Supply
5. Start flashing the MCU with the Renesas Flash Programmer (RFP)

### For demonstration using the pre-installed IO-Link master stack

1. Connect the USB cable to the board (X5)
2. Connect the 24 V Power Supply (JP3)
3. Power on 24 V Power Supply
4. Start the demonstration using the TMG TE IO-Link Device Tool V5.1.1-7475 PE or higher

For more details, please read “CCE4510 IOL Master Quick Start V1.1” (downloadable at [www.Renesas.com](http://www.Renesas.com))



## 5. Sections

The CCE4510 Evaluation Board is divided into two sections, the MCU section and the IO-Link section. Both sections can be used in combination with an IO-Link Master software stack to demonstrate a fully functional, ready-to-use IO-Link Master.

If required, both sections can also be used independently of each other. The connection between the sections can be disconnected by removing the 0R resistors R11 – R17, R26 and R27.

An additional pin-header (JP6, not placed) with 2.54 mm pitch can be used to connect an external SPI to the IO-Link section, if the on-board MCU is not used. If R26 and R27 is removed, use the dedicated pin-headers to supply the IO-Link section with 3.3 V and 24 V. **Both supply voltages are mandatory for proper functionality!**

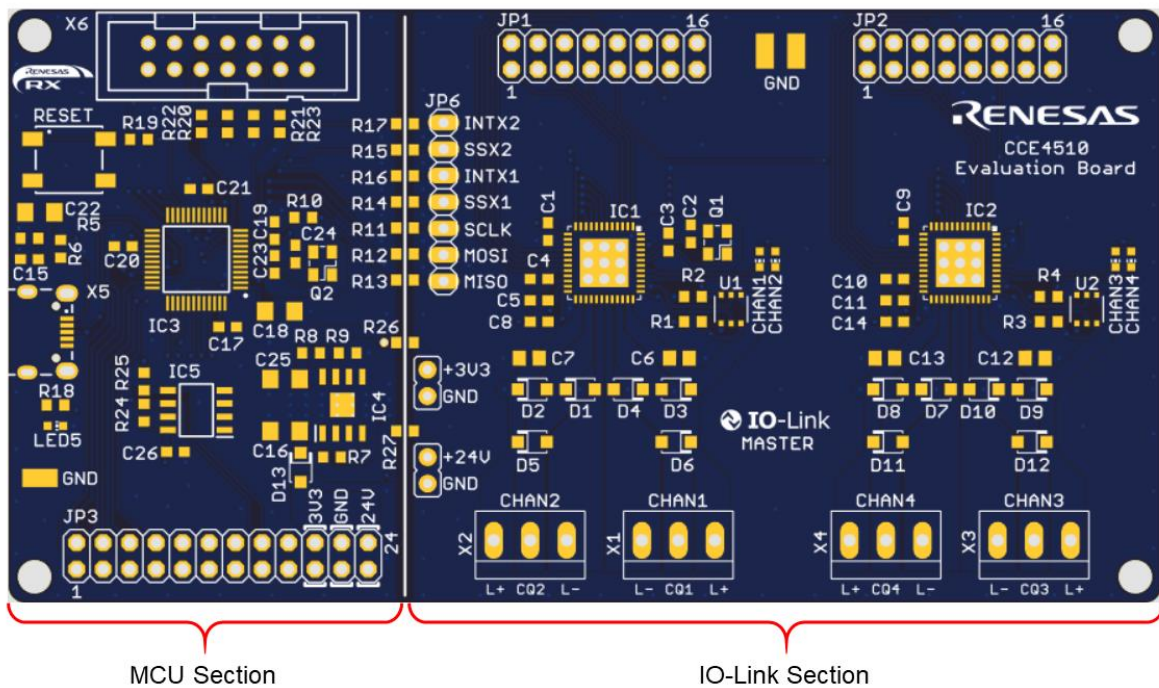

Figure 3. Sections Overview

### 5.1 IO-Link Section

The IO-Link section contains two CCE4510 IO-Link master ICs, external NMOS gate drivers (U1, U2), four LED indicators for channel activities and protection circuitry.

Each IO-Link channel (L+, CQ, L-) can be accessed via a terminal block (X1, X2, X3 and X4).

For maximum accessibility to the CCE4510 IO-Link Master ICs, all relevant pins of the CCE4510 ICs are connected to pin-headers JP1 and JP2. For a detailed overview of the accessible pins see Figure 4.

### 5.2 MCU Section

The MCU section contains a RX231 32-bit RXv2 microcontroller from Renesas, a 3.3 V LDO (IC4) for power supply, a 16 kB EEPROM (IC5) and a status LED (LED5).

The microcontroller can be programmed via USB or via FINE or SCI interface.

For maximum accessibility of the RX231, all relevant pins are connected to pin-header JP3.

## 6. Schematic and Layout

### 6.1 Connectors

Figure 4 shows all connectors of the CCE4510 evaluation board.

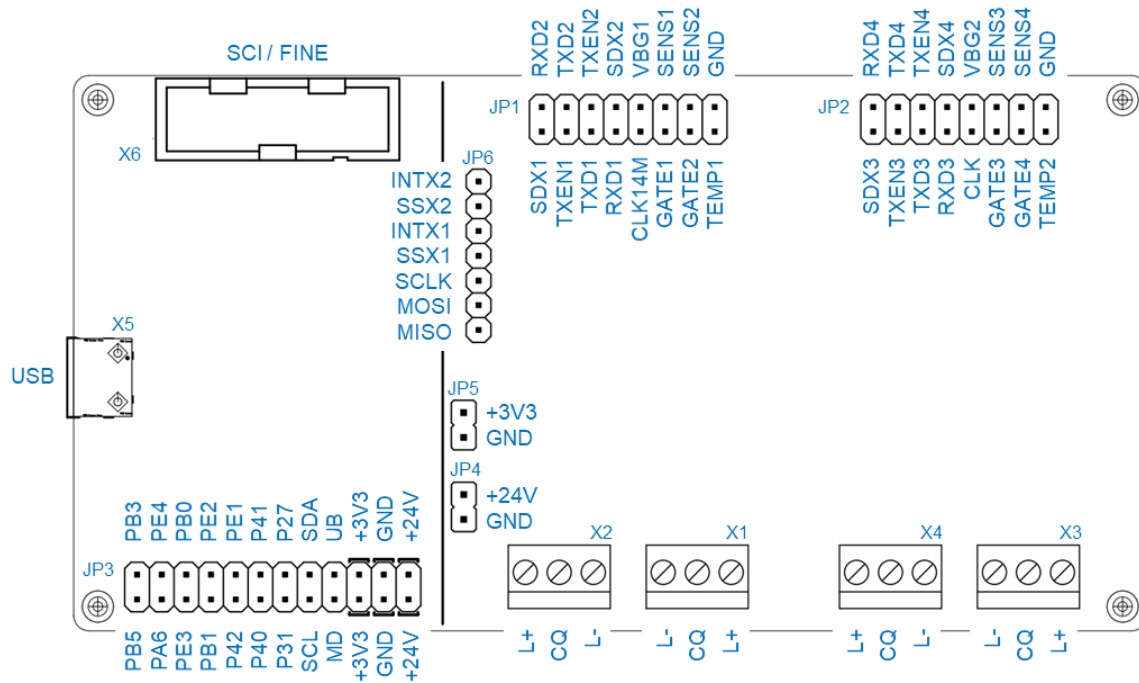

Figure 4. Connectors



## 6.2 Schematic

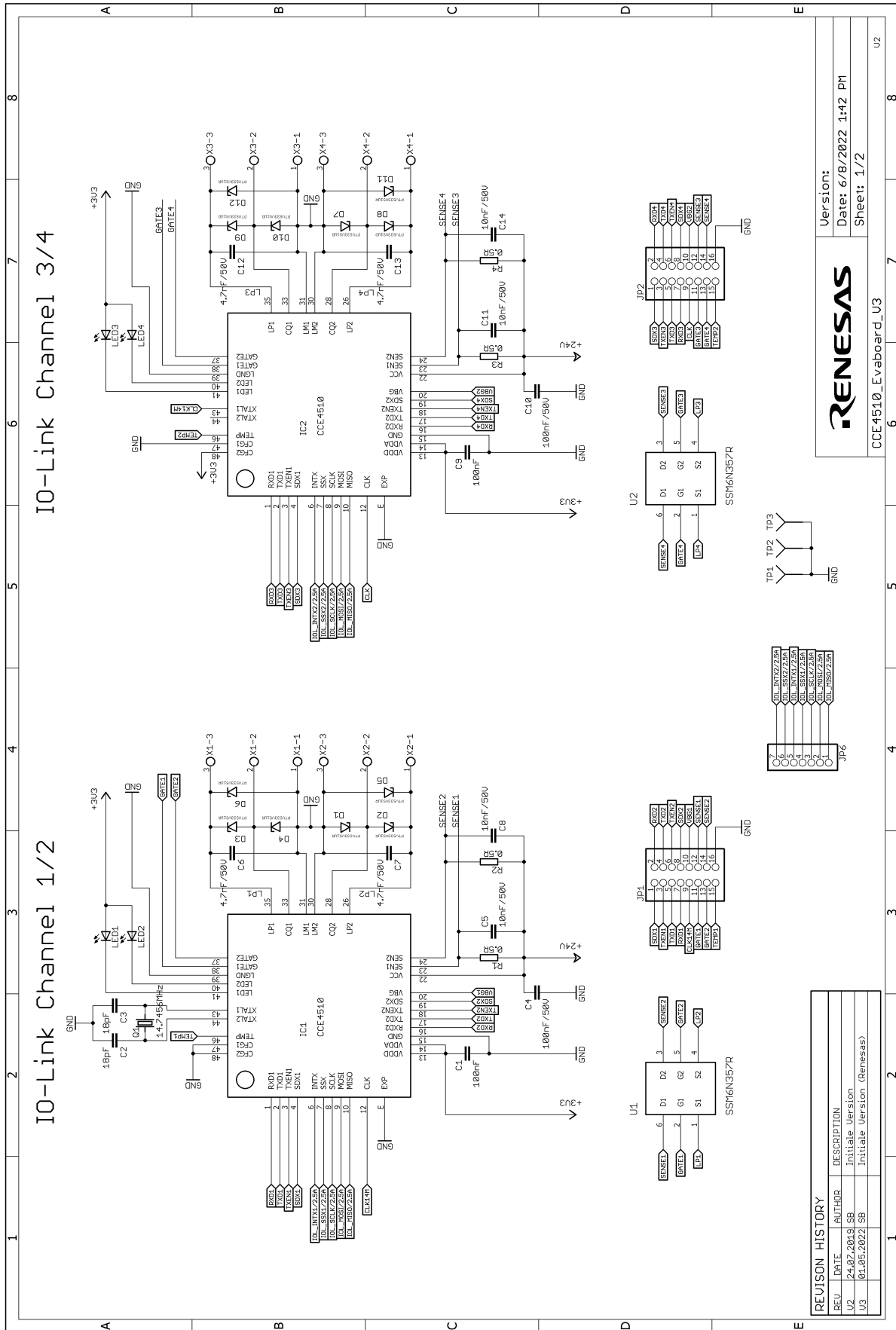

Figure 5. Schematics 1

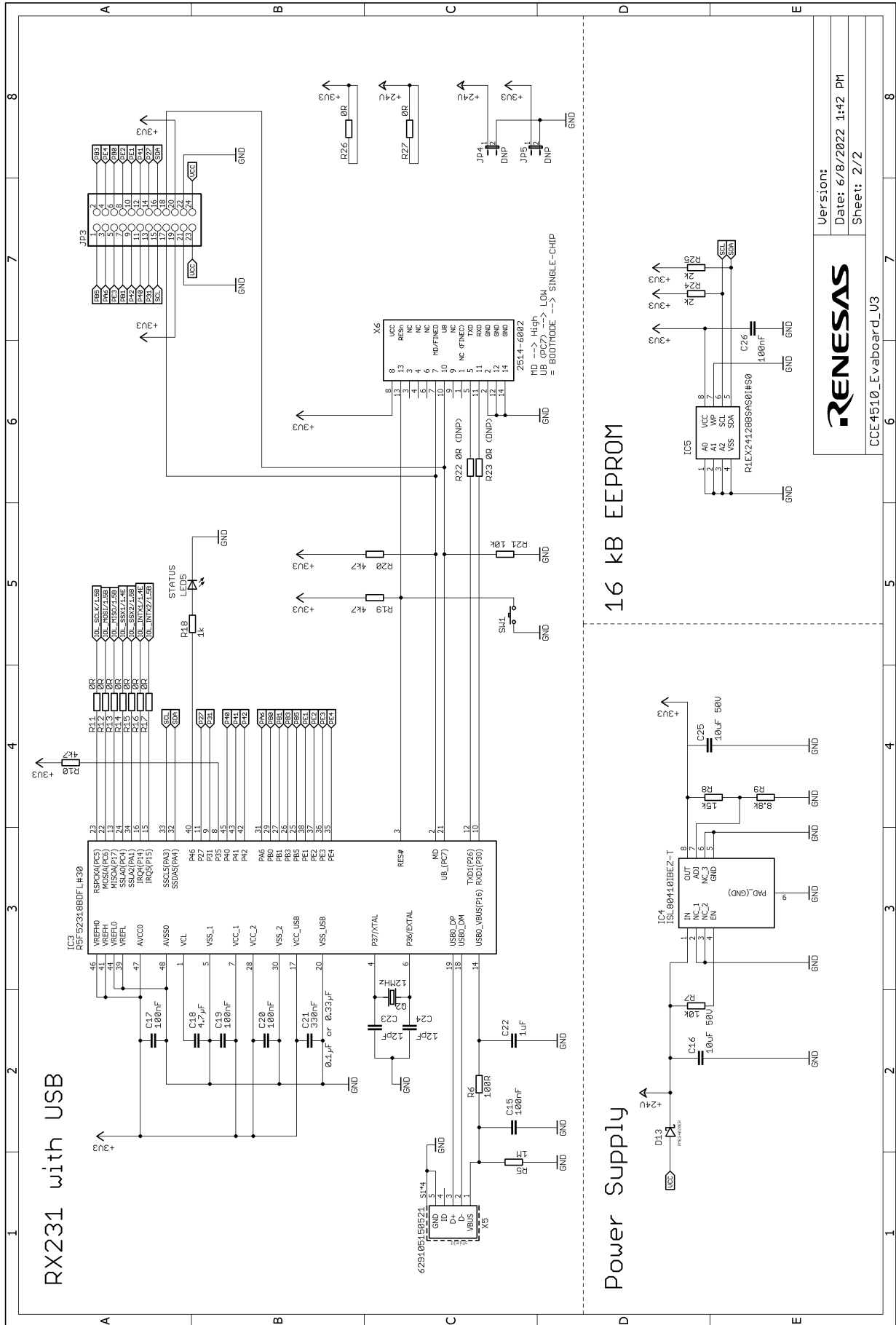

Figure 6. Schematics 2

## 6.3 Bill of Materials

Qty	Reference Designator	Description	Manufacturer	Manufacturer Part Number
9	C1, C4, C9, C10, C15, C17, C19, C20, C26	CAP, SMD, 0603, 100nF, 50V, 10%, X7R	Any	Any
2	C16, C25	CAP, SMD, 1206, 10 $\mu$ F, 50 V, 10%, X5R,	Any	Any
1	C18	CAP, SMD, 1206, 4.7 $\mu$ F, 25 V, 10%, X7R	Any	Any
2	C2, C3	CAP, SMD, 0603, 18 pF, 50 V, 10%, X7R	Any	Any
1	C21	CAP, SMD, 0603, 330 nF, 50 V, 10%, X7R	Any	Any
1	C22	CAP, SMD, 1206, 1 $\mu$ F, 16 V, 10%, X7R,	Any	Any
2	C23, C24	CAP, SMD, 0603, 12 pF, 50 V, 10%, X7R	Any	Any
4	C5, C8, C11, C14	CAP, SMD, 0603, 10 nF, 50 V, 10%, X7R	Any	Any
4	C6, C7, C12, C13	CAP, SMD, 0805, 4.7 nF, 50 V, 10%, X7R	Any	Any
12	D1, D2, D3, D4, D5, D6, D7, D8, D9, D10, D11, D12	53.3 V clamp 7.5 A Ipp TVS diode surface mount SOD-123FL	Eaton	SMFE33ALH
1	D13	Diode Schottky 40 V 2 A surface mount SOD-123FL	Panjit Semiconductor	SS2040FL_R1_00001
2	IC1, IC2	IO-Link Master PHY	Renesas Electronics	CCE4510
1	IC3	RX231 Low-power, high performance microcontroller with 32-bit RXv2 CPU core and enhanced DSP and FPU	Renesas Electronics	R5F52318BDFL#30
1	IC4	40 V, low quiescent current, 150 mA linear regulator	Renesas Electronics	ISL80410IBEZ-T
1	IC5	Two-wire serial interface 128k EEPROM (16-kword $\times$ 8-bit)	Renesas Electronics	R1EX24128BSAS0I#S0
2	JP1, JP2	2x8 pos. pin header 2.54 mm	Any	Any
1	JP3	2x12 pos. pin header 2.54 mm	Any	Any
4	LED1, LED2, LED3, LED4	Orange 605 nm LED indication – discrete 2 V 0603 (1608 metric)	ams OSRAM	LO L296-Q2S1-24-0-20-R18-Z
1	LED5	Green 573 nm LED indication – discrete 2 V	ams OSRAM	LG L29K-F2J1-24-Z
1	Q1	14.7456 MHz $\pm$ 20 ppm crystal 18 pF 120 $\Omega$ 4-SMD, no lead	Würth Elektronik	830055293
1	Q2	12 MHz $\pm$ 20 ppm crystal 12 pF 120 $\Omega$ 4-SMD, no lead	Würth Elektronik	830108338809

## CCE4510 Evaluation Board V3

4	R1, R2, R3, R4	RES, SMD, 0603, 0.5R, 100 mW, 1%	Welwyn	LRCS0603-0R5FT5
3	R10, R19, R20	RES, SMD, 0603, 4.7 k $\Omega$ , 50 V, 1.0%, 100 mW	Any	Any
11	R11, R12, R13, R14, R15, R16, R17, R22, R23, R26, R27	RES, SMD, 0603, 0 $\Omega$ , 50 V, 1.0%, 100 mW	Any	Any
1	R18	RES, SMD, 0603, 1 k $\Omega$ , 50 V, 1.0%, 100 mW	Any	Any
2	R24, R25	RES, SMD, 0603, 2 k $\Omega$ , 50 V, 1.0%, 100 mW	Any	Any
1	R5	RES, SMD, 0603, 1 M $\Omega$ , 50 V, 1.0%, 100 mW	Any	Any
1	R6	RES, SMD, 0603, 100 $\Omega$ , 50 V, 1.0%, 100 mW	Any	Any
2	R7, R21	RES, SMD, 0603, 10 k $\Omega$ , 50 V, 1.0%, 100 mW	Any	Any
1	R8	RES, SMD, 0603, 15 k $\Omega$ , 50 V, 1.0%, 100 mW	Any	Any
1	R9	RES, SMD, 0603, 8.66 k $\Omega$ , 50 V, 1.0%, 100 mW	Any	Any
1	SW1	Tactile switch SPST-NO top actuated surface mount	Würth Elektronik	430481035816
2	U1, U2	Mosfet array 2 N-channel (Dual) 60V 650 mA (T <sub>A</sub> ) 1.5 W (T <sub>A</sub> ) surface mount 6-TSOP-F	Toshiba Semiconductor	SSM6N357R,LF
4	X1, X2, X3, X4	3-Position wire to board terminal block horizontal (3.50 mm)	Metz Connect	31059103
1	X5	USB – micro B USB 2.0 receptacle connector 5 position surface mount, right angle	Würth Elektronik	629105150521
1	X6	12 Position four-wall header, 2500 series	3M	N2514-6002RB

1. The components used may vary due to limited availability.

## 6.4 Board Layout

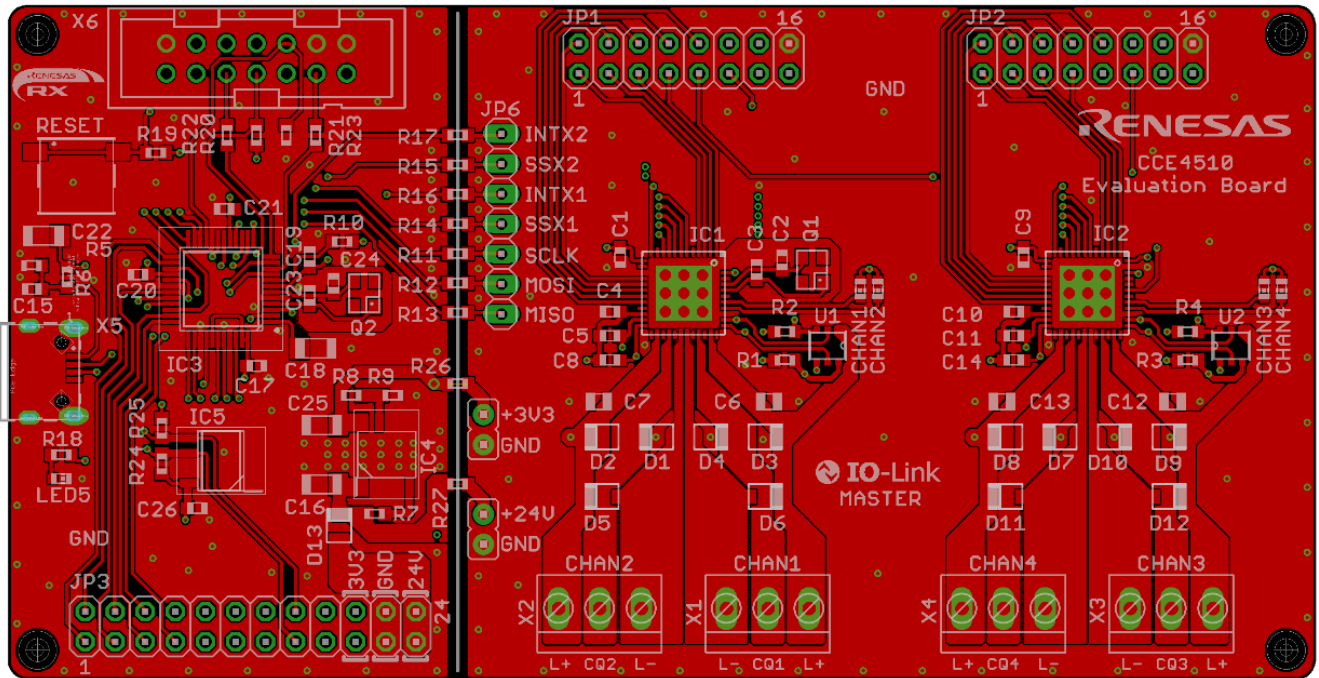

Figure 7. Top Layer

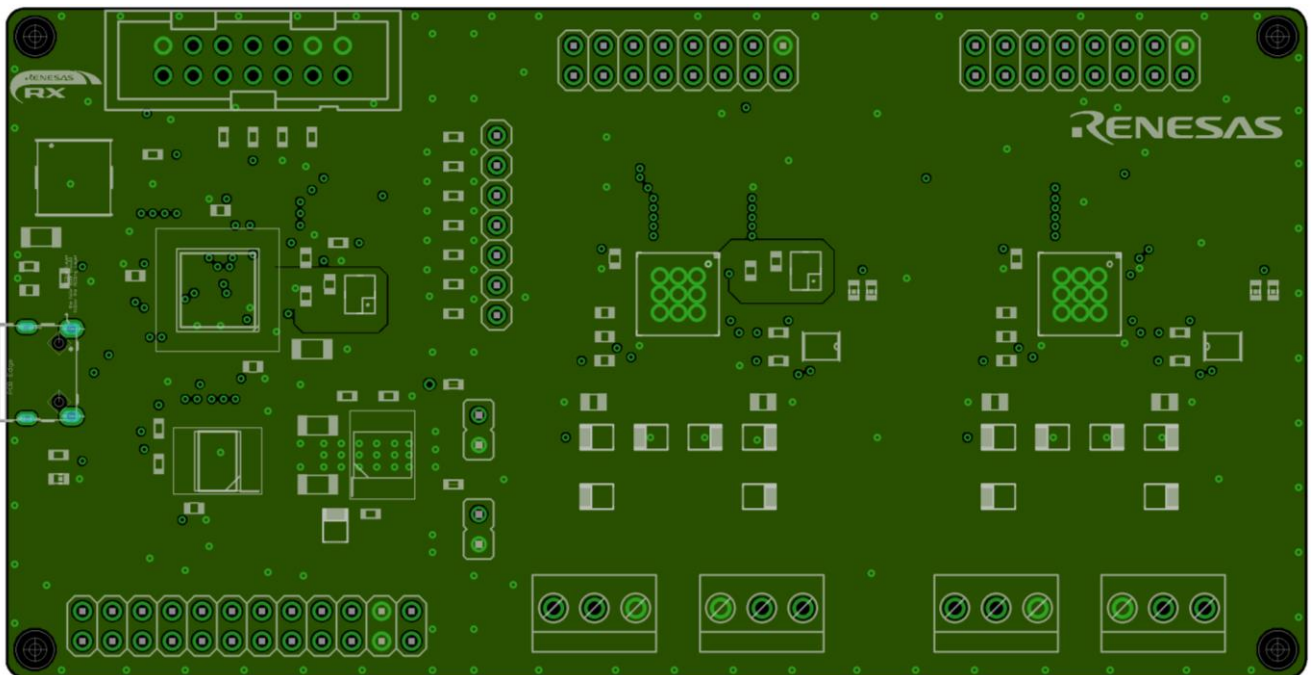

Figure 8. Second Layer (GND)

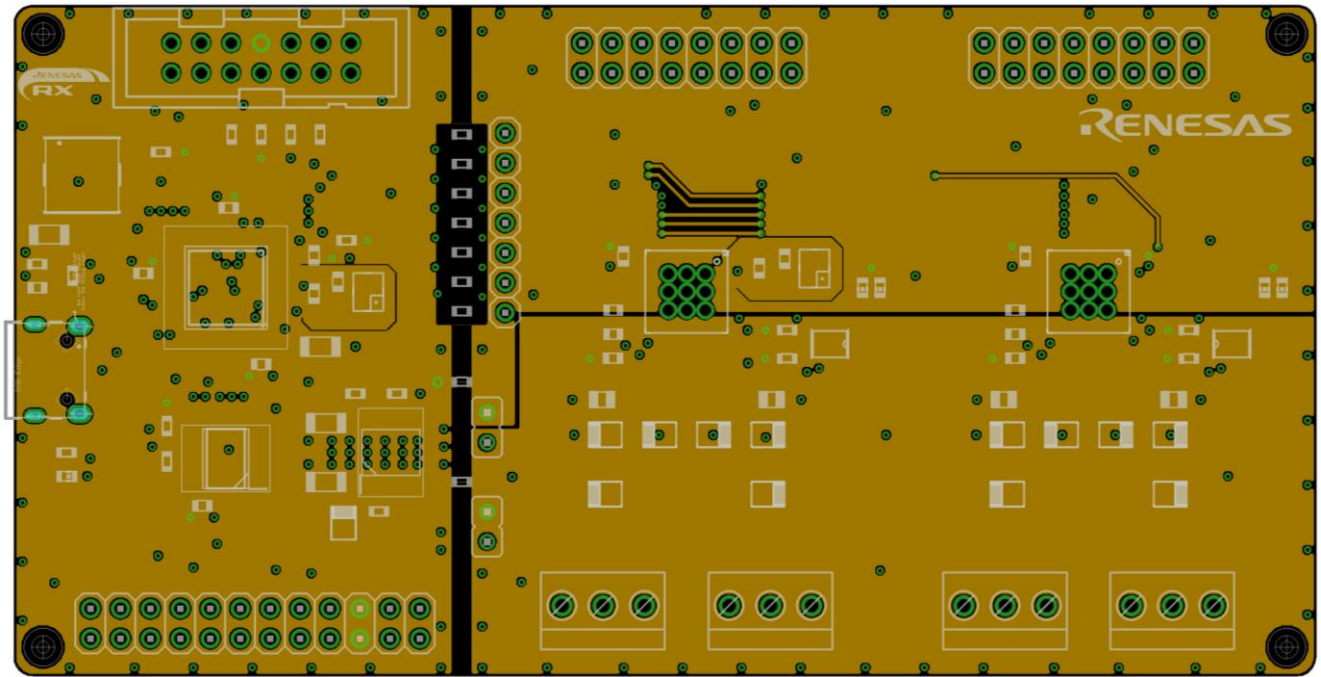

Figure 9. Third Layer (Supply)

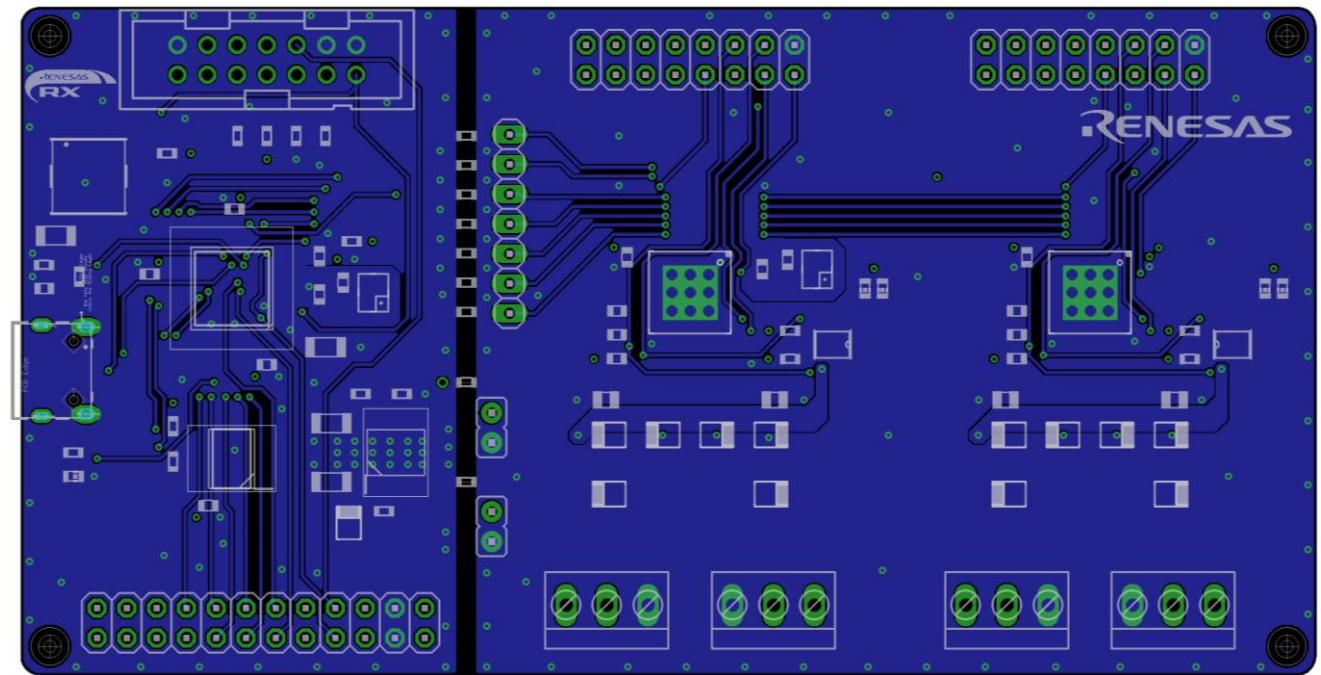

Figure 10. Bottom Layer



## 7. Ordering Information

Part Number	Description
CCE4510-EVAL-V3	CCE4510 Evaluation Board V3

## 8. Glossary

Term	Description
CAP	Capacitor
EEPROM	Electrically erasable programmable read-only memory
IC	Integrated circuit
IDE	Integrated development environment
IO	Input output
IOLM	IO-Link Master description
kB	Kilo Byte
LDO	Low dropout voltage regulator
LED	Light emitting diode
NMOS	N-type metal-oxide semiconductor
RES	Resistor
RFP	Renesas flash programmer
RX	Renesas microcontroller family
SCI	Serial communications interface
SMD	Surface mount device
SPI	Serial peripheral interface
TMG TE	TMG Technologie und Engineering GmbH
USB	Universal serial bus

## 9. Revision History

Revision	Date	Description
1.00	Aug 9, 2023	Initial release.



## IMPORTANT NOTICE AND DISCLAIMER

RENESAS ELECTRONICS CORPORATION AND ITS SUBSIDIARIES (“RENESAS”) PROVIDES TECHNICAL SPECIFICATIONS AND RELIABILITY DATA (INCLUDING DATASHEETS), DESIGN RESOURCES (INCLUDING REFERENCE DESIGNS), APPLICATION OR OTHER DESIGN ADVICE, WEB TOOLS, SAFETY INFORMATION, AND OTHER RESOURCES “AS IS” AND WITH ALL FAULTS, AND DISCLAIMS ALL WARRANTIES, EXPRESS OR IMPLIED, INCLUDING, WITHOUT LIMITATION, ANY IMPLIED WARRANTIES OF MERCHANTABILITY, FITNESS FOR A PARTICULAR PURPOSE, OR NON-INFRINGEMENT OF THIRD-PARTY INTELLECTUAL PROPERTY RIGHTS.

These resources are intended for developers who are designing with Renesas products. You are solely responsible for (1) selecting the appropriate products for your application, (2) designing, validating, and testing your application, and (3) ensuring your application meets applicable standards, and any other safety, security, or other requirements. These resources are subject to change without notice. Renesas grants you permission to use these resources only to develop an application that uses Renesas products. Other reproduction or use of these resources is strictly prohibited. No license is granted to any other Renesas intellectual property or to any third-party intellectual property. Renesas disclaims responsibility for, and you will fully indemnify Renesas and its representatives against, any claims, damages, costs, losses, or liabilities arising from your use of these resources. Renesas' products are provided only subject to Renesas' Terms and Conditions of Sale or other applicable terms agreed to in writing. No use of any Renesas resources expands or otherwise alters any applicable warranties or warranty disclaimers for these products.

(Disclaimer Rev.1.01)

### Corporate Headquarters

TOYOSU FORESIA, 3-2-24 Toyosu,  
Koto-ku, Tokyo 135-0061, Japan  
[www.renesas.com](http://www.renesas.com)

### Trademarks

Renesas and the Renesas logo are trademarks of Renesas Electronics Corporation. All trademarks and registered trademarks are the property of their respective owners.

### Contact Information

For further information on a product, technology, the most up-to-date version of a document, or your nearest sales office, please visit [www.renesas.com/contact-us/](http://www.renesas.com/contact-us/).