

# RA8D1 Group

Evaluation Kit for RA8D1 Microcontroller Group  
EK-RA8D1 v1  
User's Manual

Renesas RA Family  
RA8 Series

All information contained in these materials, including products and product specifications, represents information on the product at the time of publication and is subject to change by Renesas Electronics Corp. without notice. Please review the latest information published by Renesas Electronics Corp. through various means, including the Renesas Electronics Corp. website (<https://www.renesas.com>).

## Notice

1. Descriptions of circuits, software and other related information in this document are provided only to illustrate the operation of semiconductor products and application examples. You are fully responsible for the incorporation or any other use of the circuits, software, and information in the design of your product or system. Renesas Electronics disclaims any and all liability for any losses and damages incurred by you or third parties arising from the use of these circuits, software, or information.
2. Renesas Electronics hereby expressly disclaims any warranties against and liability for infringement or any other claims involving patents, copyrights, or other intellectual property rights of third parties, by or arising from the use of Renesas Electronics products or technical information described in this document, including but not limited to, the product data, drawings, charts, programs, algorithms, and application examples.
3. No license, express, implied or otherwise, is granted hereby under any patents, copyrights or other intellectual property rights of Renesas Electronics or others.
4. You shall be responsible for determining what licenses are required from any third parties, and obtaining such licenses for the lawful import, export, manufacture, sales, utilization, distribution or other disposal of any products incorporating Renesas Electronics products, if required.
5. You shall not alter, modify, copy, or reverse engineer any Renesas Electronics product, whether in whole or in part. Renesas Electronics disclaims any and all liability for any losses or damages incurred by you or third parties arising from such alteration, modification, copying or reverse engineering.
6. Renesas Electronics products are classified according to the following two quality grades: "Standard" and "High Quality". The intended applications for each Renesas Electronics product depends on the product's quality grade, as indicated below.
  - "Standard": Computers; office equipment; communications equipment; test and measurement equipment; audio and visual equipment; home electronic appliances; machine tools; personal electronic equipment; industrial robots; etc.
  - "High Quality": Transportation equipment (automobiles, trains, ships, etc.); traffic control (traffic lights); large-scale communication equipment; key financial terminal systems; safety control equipment; etc.

Unless expressly designated as a high reliability product or a product for harsh environments in a Renesas Electronics data sheet or other Renesas Electronics document, Renesas Electronics products are not intended or authorized for use in products or systems that may pose a direct threat to human life or bodily injury (artificial life support devices or systems; surgical implantations; etc.), or may cause serious property damage (space system; undersea repeaters; nuclear power control systems; aircraft control systems; key plant systems; military equipment; etc.). Renesas Electronics disclaims any and all liability for any damages or losses incurred by you or any third parties arising from the use of any Renesas Electronics product that is inconsistent with any Renesas Electronics data sheet, user's manual or other Renesas Electronics document.
7. No semiconductor product is absolutely secure. Notwithstanding any security measures or features that may be implemented in Renesas Electronics hardware or software products, Renesas Electronics shall have absolutely no liability arising out of any vulnerability or security breach, including but not limited to any unauthorized access to or use of a Renesas Electronics product or a system that uses a Renesas Electronics product. RENESAS ELECTRONICS DOES NOT WARRANT OR GUARANTEE THAT RENESAS ELECTRONICS PRODUCTS, OR ANY SYSTEMS CREATED USING RENESAS ELECTRONICS PRODUCTS WILL BE INVULNERABLE OR FREE FROM CORRUPTION, ATTACK, VIRUSES, INTERFERENCE, HACKING, DATA LOSS OR THEFT, OR OTHER SECURITY INTRUSION ("Vulnerability Issues"). RENESAS ELECTRONICS DISCLAIMS ANY AND ALL RESPONSIBILITY OR LIABILITY ARISING FROM OR RELATED TO ANY VULNERABILITY ISSUES. FURTHERMORE, TO THE EXTENT PERMITTED BY APPLICABLE LAW, RENESAS ELECTRONICS DISCLAIMS ANY AND ALL WARRANTIES, EXPRESS OR IMPLIED, WITH RESPECT TO THIS DOCUMENT AND ANY RELATED OR ACCOMPANYING SOFTWARE OR HARDWARE, INCLUDING BUT NOT LIMITED TO THE IMPLIED WARRANTIES OF MERCHANTABILITY, OR FITNESS FOR A PARTICULAR PURPOSE.
8. When using Renesas Electronics products, refer to the latest product information (data sheets, user's manuals, application notes, "General Notes for Handling and Using Semiconductor Devices" in the reliability handbook, etc.), and ensure that usage conditions are within the ranges specified by Renesas Electronics with respect to maximum ratings, operating power supply voltage range, heat dissipation characteristics, installation, etc. Renesas Electronics disclaims any and all liability for any malfunctions, failure or accident arising out of the use of Renesas Electronics products outside of such specified ranges.
9. Although Renesas Electronics endeavors to improve the quality and reliability of Renesas Electronics products, semiconductor products have specific characteristics, such as the occurrence of failure at a certain rate and malfunctions under certain use conditions. Unless designated as a high reliability product or a product for harsh environments in a Renesas Electronics data sheet or other Renesas Electronics document, Renesas Electronics products are not subject to radiation resistance design. You are responsible for implementing safety measures to guard against the possibility of bodily injury, injury or damage caused by fire, and/or danger to the public in the event of a failure or malfunction of Renesas Electronics products, such as safety design for hardware and software, including but not limited to redundancy, fire control and malfunction prevention, appropriate treatment for aging degradation or any other appropriate measures. Because the evaluation of microcomputer software alone is very difficult and impractical, you are responsible for evaluating the safety of the final products or systems manufactured by you.
10. Please contact a Renesas Electronics sales office for details as to environmental matters such as the environmental compatibility of each Renesas Electronics product. You are responsible for carefully and sufficiently investigating applicable laws and regulations that regulate the inclusion or use of controlled substances, including without limitation, the EU RoHS Directive, and using Renesas Electronics products in compliance with all these applicable laws and regulations. Renesas Electronics disclaims any and all liability for damages or losses occurring as a result of your noncompliance with applicable laws and regulations.
11. Renesas Electronics products and technologies shall not be used for or incorporated into any products or systems whose manufacture, use, or sale is prohibited under any applicable domestic or foreign laws or regulations. You shall comply with any applicable export control laws and regulations promulgated and administered by the governments of any countries asserting jurisdiction over the parties or transactions.
12. It is the responsibility of the buyer or distributor of Renesas Electronics products, or any other party who distributes, disposes of, or otherwise sells or transfers the product to a third party, to notify such third party in advance of the contents and conditions set forth in this document.
13. This document shall not be reprinted, reproduced or duplicated in any form, in whole or in part, without prior written consent of Renesas Electronics.
14. Please contact a Renesas Electronics sales office if you have any questions regarding the information contained in this document or Renesas Electronics products.

(Note1) "Renesas Electronics" as used in this document means Renesas Electronics Corporation and also includes its directly or indirectly controlled subsidiaries.

(Note2) "Renesas Electronics product(s)" means any product developed or manufactured by or for Renesas Electronics.

(Rev.5.0-1 October 2020)

## Corporate Headquarters

TOYOSU FORESIA, 3-2-24 Toyosu,  
Koto-ku, Tokyo 135-0061, Japan  
[www.renesas.com](http://www.renesas.com)

## Trademarks

Renesas and the Renesas logo are trademarks of Renesas Electronics Corporation. All trademarks and registered trademarks are the property of their respective owners.

## Contact information

For further information on a product, technology, the most up-to-date version of a document, or your nearest sales office, please visit:  
[www.renesas.com/contact/](http://www.renesas.com/contact/).

# General Precautions in the Handling of Microprocessing Unit and Microcontroller Unit Products

The following usage notes are applicable to all Microprocessing unit and Microcontroller unit products from Renesas. For detailed usage notes on the products covered by this document, refer to the relevant sections of the document as well as any technical updates that have been issued for the products.

## 1. Precaution against Electrostatic Discharge (ESD)

A strong electrical field, when exposed to a CMOS device, can cause destruction of the gate oxide and ultimately degrade the device operation. Steps must be taken to stop the generation of static electricity as much as possible, and quickly dissipate it when it occurs. Environmental control must be adequate. When it is dry, a humidifier should be used. This is recommended to avoid using insulators that can easily build up static electricity. Semiconductor devices must be stored and transported in an anti-static container, static shielding bag or conductive material. All test and measurement tools including work benches and floors must be grounded. The operator must also be grounded using a wrist strap. Semiconductor devices must not be touched with bare hands. Similar precautions must be taken for printed circuit boards with mounted semiconductor devices.

## 2. Processing at power-on

The state of the product is undefined at the time when power is supplied. The states of internal circuits in the LSI are indeterminate and the states of register settings and pins are undefined at the time when power is supplied. In a finished product where the reset signal is applied to the external reset pin, the states of pins are not guaranteed from the time when power is supplied until the reset process is completed. In a similar way, the states of pins in a product that is reset by an on-chip power-on reset function are not guaranteed from the time when power is supplied until the power reaches the level at which resetting is specified.

## 3. Input of signal during power-off state

Do not input signals or an I/O pull-up power supply while the device is powered off. The current injection that results from input of such a signal or I/O pull-up power supply may cause malfunction and the abnormal current that passes in the device at this time may cause degradation of internal elements. Follow the guideline for input signal during power-off state as described in your product documentation.

## 4. Handling of unused pins

Handle unused pins in accordance with the directions given under handling of unused pins in the manual. The input pins of CMOS products are generally in the high-impedance state. In operation with an unused pin in the open-circuit state, extra electromagnetic noise is induced in the vicinity of the LSI, an associated shoot-through current flows internally, and malfunctions occur due to the false recognition of the pin state as an input signal become possible.

## 5. Clock signals

After applying a reset, only release the reset line after the operating clock signal becomes stable. When switching the clock signal during program execution, wait until the target clock signal is stabilized. When the clock signal is generated with an external resonator or from an external oscillator during a reset, ensure that the reset line is only released after full stabilization of the clock signal. Additionally, when switching to a clock signal produced with an external resonator or by an external oscillator while program execution is in progress, wait until the target clock signal is stable.

## 6. Voltage application waveform at input pin

Waveform distortion due to input noise or a reflected wave may cause malfunction. If the input of the CMOS device stays in the area between  $V_{IL}$  (Max.) and  $V_{IH}$  (Min.) due to noise, for example, the device may malfunction. Take care to prevent chattering noise from entering the device when the input level is fixed, and also in the transition period when the input level passes through the area between  $V_{IL}$  (Max.) and  $V_{IH}$  (Min.).

## 7. Prohibition of access to reserved addresses

Access to reserved addresses is prohibited. The reserved addresses are provided for possible future expansion of functions. Do not access these addresses as the correct operation of the LSI is not guaranteed.

## 8. Differences between products

Before changing from one product to another, for example to a product with a different part number, confirm that the change will not lead to problems. The characteristics of a microprocessing unit or microcontroller unit products in the same group but having a different part number might differ in terms of internal memory capacity, layout pattern, and other factors, which can affect the ranges of electrical characteristics, such as characteristic values, operating margins, immunity to noise, and amount of radiated noise. When changing to a product with a different part number, implement a system-evaluation test for the given product.

## Renesas EK-RA8D1 Disclaimer

By using this EK-RA8D1, the User accepts the following terms, which are in addition to, and control in the event of disagreement, with Renesas' General Terms and Conditions available at [renesas.com/legal-notices](https://www.renesas.com/legal-notices).

The EK-RA8D1 is not guaranteed to be error free, and the entire risk as to the results and performance of the EK-RA8D1 is assumed by the User. The EK-RA8D1 is provided by Renesas on an "as is" basis without warranty of any kind whether express or implied, including but not limited to the implied warranties of good workmanship, fitness for a particular purpose, title, merchantability, and non-infringement of intellectual property rights. Renesas expressly disclaims any implied warranty.

Renesas does not consider the EK-RA8D1 to be a finished product and therefore the EK-RA8D1 may not comply with some requirements applicable to finished products, including, but not limited to recycling, restricted substances and electromagnetic compatibility regulations. Refer to Certifications section, for information about certifications and compliance information for the EK-RA8D1. It is the kit User's responsibility to make sure the kit meets any local requirements applicable to their region.

Renesas or its affiliates shall in no event be liable for any loss of profit, loss of data, loss of contract, loss of business, damage to reputation or goodwill, any economic loss, any reprogramming or recall costs (whether the foregoing losses are direct or indirect) nor shall Renesas or its affiliates be liable for any other direct or indirect special, incidental or consequential damages arising out of or in relation to the use of this EK-RA8D1, even if Renesas or its affiliates have been advised of the possibility of such damages.

Renesas has used reasonable care in preparing the information included in this document, but Renesas does not warrant that such information is error free nor does Renesas guarantee an exact match for every application or parameter to part numbers designated by other vendors listed herein. The information provided in this document is intended solely to enable the use of Renesas products. No express or implied license to any intellectual property right is granted by this document or in connection with the sale of Renesas products. Renesas reserves the right to make changes to specifications and product descriptions at any time without notice. Renesas assumes no liability for any damages incurred by you resulting from errors in or omissions from the information included herein. Renesas cannot verify, and assumes no liability for, the accuracy of information available on another company's website.

## Precautions

This Evaluation Kit is only intended for use in a laboratory environment under ambient temperature and humidity conditions. A safe separation distance should be used between this and any sensitive equipment. Its use outside the laboratory, classroom, study area, or similar such area invalidates conformity with the protection requirements of the Electromagnetic Compatibility Directive and could lead to prosecution.

The product generates, uses, and can radiate radio frequency energy and may cause harmful interference to radio communications. There is no guarantee that interference will not occur in a particular installation. If this equipment causes harmful interference to radio or television reception, which can be determined by turning the equipment off or on, you are encouraged to try to correct the interference by one or more of the following measures:

- Ensure attached cables do not lie across the equipment.
- Reorient the receiving antenna.
- Increase the distance between the equipment and the receiver.
- Connect the equipment into an outlet on a circuit different from that which the receiver is connected.
- Power down the equipment when not in use.
- Consult the dealer or an experienced radio/TV technician for help.

Note: It is recommended that wherever possible shielded interface cables are used.

The product is potentially susceptible to certain EMC phenomena. To mitigate against them it is recommended that the following measures be undertaken:

- The user is advised that mobile phones should not be used within 10 m of the product when in use.
- The user is advised to take ESD precautions when handling the equipment.

The Evaluation Kit does not represent an ideal reference design for an end product and does not fulfill the regulatory standards for an end product.

## Renesas RA Family

**EK-RA8D1 v1**
**Contents**

1. Kit Overview .....	5
1.1 Assumptions and Advisory Notes.....	8
2. Kit Contents .....	9
3. Ordering Information.....	10
4. Hardware Architecture and Default Configuration .....	10
4.1 Kit Architecture .....	10
4.2 System Block Diagram .....	12
4.3 Jumper Configuration .....	13
4.3.1 Copper Jumpers .....	13
4.3.2 Traditional Pin Header Jumpers.....	13
4.3.3 Default Jumper Configuration.....	13
4.3.4 Default Switch Configuration .....	15
5. System Control and Ecosystem Access Area .....	16
5.1 Power .....	17
5.1.1 Power Supply Options.....	17
5.1.2 Power Supply Considerations .....	18
5.1.3 Power-up Behavior .....	18
5.2 Debug and Trace.....	18
5.2.1 Debug On-Board .....	19
5.2.2 Debug In .....	20
5.2.3 Debug Out .....	21
5.3 Ecosystem .....	21
5.3.1 Seeed Grove® Connectors .....	22
5.3.2 SparkFun Qwiic® Connector .....	22
5.3.3 Digilent Pmod™ Connectors .....	23
5.3.4 Arduino™ Connector.....	24
5.3.5 MikroElektronika™ mikroBUS Connector .....	26
5.4 Connectivity .....	26
5.4.1 USB Full Speed .....	26
5.4.2 I3C .....	27
5.5 Miscellaneous.....	27
5.5.1 User and Power LEDs.....	27
5.5.2 User and Reset Switches .....	28

5.5.3	MCU Boot Mode .....	29
6.	Special Feature Access Area .....	29
6.1	Ethernet .....	29
6.2	USB High Speed .....	30
6.3	Octo-SPI Flash .....	31
6.4	SDRAM .....	32
6.5	Parallel Graphics Expansion Port .....	33
7.	MCU Native Pin Access Area .....	35
7.1	Breakout Pin Headers .....	35
7.2	MCU and USB Current Measurement .....	35
8.	Expansion Boards .....	37
8.1	MIPI Graphics Expansion Board .....	37
8.1.1	Connecting the Graphics Expansion Board to the EK-RA8D1 Board .....	37
8.1.2	Signal Assignments .....	39
8.2	Camera Expansion Board .....	39
8.2.1	Connecting the Camera Expansion Board to the EK-RA8D1 Board .....	39
8.2.2	Signal Assignments .....	41
9.	Certifications .....	42
9.1	EMC/EMI Standards .....	42
9.2	Material Selection, Waste, Recycling and Disposal Standards .....	42
9.3	Safety Standards .....	42
10.	Design and Manufacturing Information .....	43
11.	Website and Support .....	43
	Revision History .....	44

## Figures

Figure 1.	EK-RA8D1 Board Top Side .....	6
Figure 2.	EK-RA8D1 Board Bottom Side .....	7
Figure 3.	EK-RA8D1 Kit Contents .....	9
Figure 4.	EK-RA8D1 Board Functional Area Definitions .....	11
Figure 5.	EK-RA8D1 Board Block Diagram .....	12
Figure 6.	Copper Jumpers .....	13
Figure 7.	System Control and Ecosystem Access Area .....	16
Figure 8.	Power Supply Options .....	17
Figure 9.	Test Point Location .....	18
Figure 10.	EK-RA8D1 Debug Interface .....	20
Figure 11.	Seeed Grove and SparkFun Qwiic® Connector Footprints .....	22

Figure 12. Pmod 1 Connector .....	24
Figure 13. Pmod 2 Connector .....	24
Figure 14. Arduino Uno Connectors .....	25
Figure 15. mikroBUS Connector .....	26
Figure 16. USB Full Speed Connector .....	27
Figure 17. User LEDs .....	28
Figure 18. Power LED .....	28
Figure 19. Reset and User Switches .....	28
Figure 20. Boot Mode .....	29
Figure 21. Special Feature Access Area .....	29
Figure 22. Ethernet Connector .....	30
Figure 23. USB High Speed Connector .....	31
Figure 24. Octo-SPI Flash .....	31
Figure 25. SDRAM .....	33
Figure 26. Parallel Graphics Expansion Port .....	34
Figure 27. Native Pin Access Area .....	35
Figure 28. RA USB Current Measurement Circuit .....	36
Figure 29. RA +3.3 V Current Measurement Circuit .....	36
Figure 30. RA MCU and USB Current Measurement .....	36
Figure 31. EK-RA8D1 Board Connected with MIPI Graphics Expansion Board .....	38
Figure 32. EK-RA8D1 Board Connected with Camera Expansion Board .....	40

## Tables

Table 1. Kit Architecture .....	10
Table 2. Default Jumper Configuration .....	13
Table 3. Default Switch Configuration (SW1) .....	15
Table 4. Permitted Switch Configuration (SW1) .....	15
Table 5. Debug Modes .....	18
Table 6. Jumper Connection Summary for Different Debug Modes .....	19
Table 7. Debug USB Port Assignments .....	19
Table 8. Debug On-Board Jumper Configuration .....	19
Table 9. Debug In Mode Jumper Configuration .....	20
Table 10. JTAG/SWO/SWD/ETM Debug Port Assignments .....	20
Table 11. JTAG/SWO/SWD Debug Port Assignments .....	21
Table 12. Debug Out Jumper Configuration .....	21
Table 13. Grove 1 Port Assignments .....	22
Table 14. Grove 2 Port Assignments .....	22
Table 15. Qwiic Port Assignments .....	22
Table 16. Pmod 1 Port Assignments .....	23
Table 17. Pmod 2 Port Assignments .....	24

---

Table 18.	Arduino Uno Port Assignments.....	24
Table 19.	mikroBUS Assignments .....	26
Table 20.	USB Full Speed Port Assignments .....	27
Table 21.	I <sup>2</sup> C/I <sup>3</sup> C Pullup Configuration .....	27
Table 22.	EK-RA8D1 Board LED Functions .....	27
Table 23.	EK-RA8D1 Board Switches .....	28
Table 24.	Ethernet Port Assignments .....	30
Table 25.	Ethernet Components .....	30
Table 26.	USB High Speed Port Assignments .....	31
Table 27.	Octo-SPI Flash Assignments .....	31
Table 28.	SDRAM Assignments .....	32
Table 29.	Parallel Graphics Expansion Port Assignments .....	33
Table 30.	MIPI Graphics Expansion Port Assignments .....	39
Table 31.	Camera Expansion Port Assignments .....	41
Table 32.	EK-RA8D1 Board Design Package Contents .....	43
Table 33.	MIPI Graphics Expansion Board Design Package Contents .....	43



## 1. Kit Overview

The EK-RA8D1, an Evaluation Kit for RA8D1 MCU Group, enables users to seamlessly evaluate the features of the RA8D1 MCU group and develop embedded systems applications using Flexible Software Package (FSP) and e<sup>2</sup> studio IDE. The users can utilize rich on-board features along with their choice of popular ecosystems add-ons to bring their big ideas to life.

The EK-RA8D1 kit consists of three boards: the EK-RA8D1 board featuring the RA8D1 MCU, MIPI Graphics Expansion Board, and Camera Expansion Board.

The key features of the EK-RA8D1 board are categorized in three groups (consistent with the architecture of the kit, with a few exceptions) as follows:

### MCU Native Pin Access

- R7FA8D1BHECBD MCU (referred to as RA MCU)
- 480 MHz, Arm<sup>®</sup> Cortex<sup>®</sup>-M85 core
- 2 MB Code Flash, 1 MB SRAM
- 224 pins, BGA package
- Native pin access through 6 x 20-pin, and 1 x 40-pin male header
- MCU current measurement points for precision current consumption measurement
- Multiple clock sources – RA MCU oscillator and sub-clock oscillator crystals, providing precision 20.000 MHz and 32,768 Hz reference clocks. Additional low-precision clocks are available internal to the RA MCU

### System Control and Ecosystem Access

- USB Full Speed Host and Device (micro-AB connector)
- Four 5 V input sources
  - USB (Debug, Full Speed, High Speed)
  - External power supply (using surface mount clamp test points and power input vias)
- Three Debug modes
  - Debug on-board (SWD and JTAG)
  - Debug in (ETM, SWD, SWO and JTAG)
  - Debug out (SWD, SWO and JTAG)
- User LEDs and buttons
  - Three User LEDs (red, blue, green)
  - Power LED (white) indicating availability of regulated power
  - Debug LED (yellow) indicating the debug connection
  - Two User buttons
  - One Reset button
- Five most popular ecosystems expansions
  - Two Seeed Grove<sup>®</sup> system (I<sup>2</sup>C/I<sup>3</sup>C/Analog) connectors (not populated)
  - SparkFun<sup>®</sup> Qwiic<sup>®</sup> connector (not populated)
  - Two Digilent Pmod<sup>™</sup> (SPI, UART and I<sup>2</sup>C) connectors
  - Arduino<sup>™</sup> (Uno R3) connector
  - MikroElektronika<sup>™</sup> mikroBUS connector
- MCU boot configuration jumper

### Special Feature Access

- Ethernet (RJ45 RMII interface)
- USB High Speed Host and Device (micro-AB connector)
- 64 MB (512 Mb) External Octo-SPI Flash (present in the MCU Native Pin Access area)
- 64 MB (512 Mb) SDRAM (present in the MCU Native Pin Access area)
- MIPI Graphics Expansion Port (present in the MCU Native Pin Access area)
- Parallel Graphics Expansion Port (present in the MCU Native Pin Access area)
- Camera Expansion Port (present in the MCU Native Pin Access area)

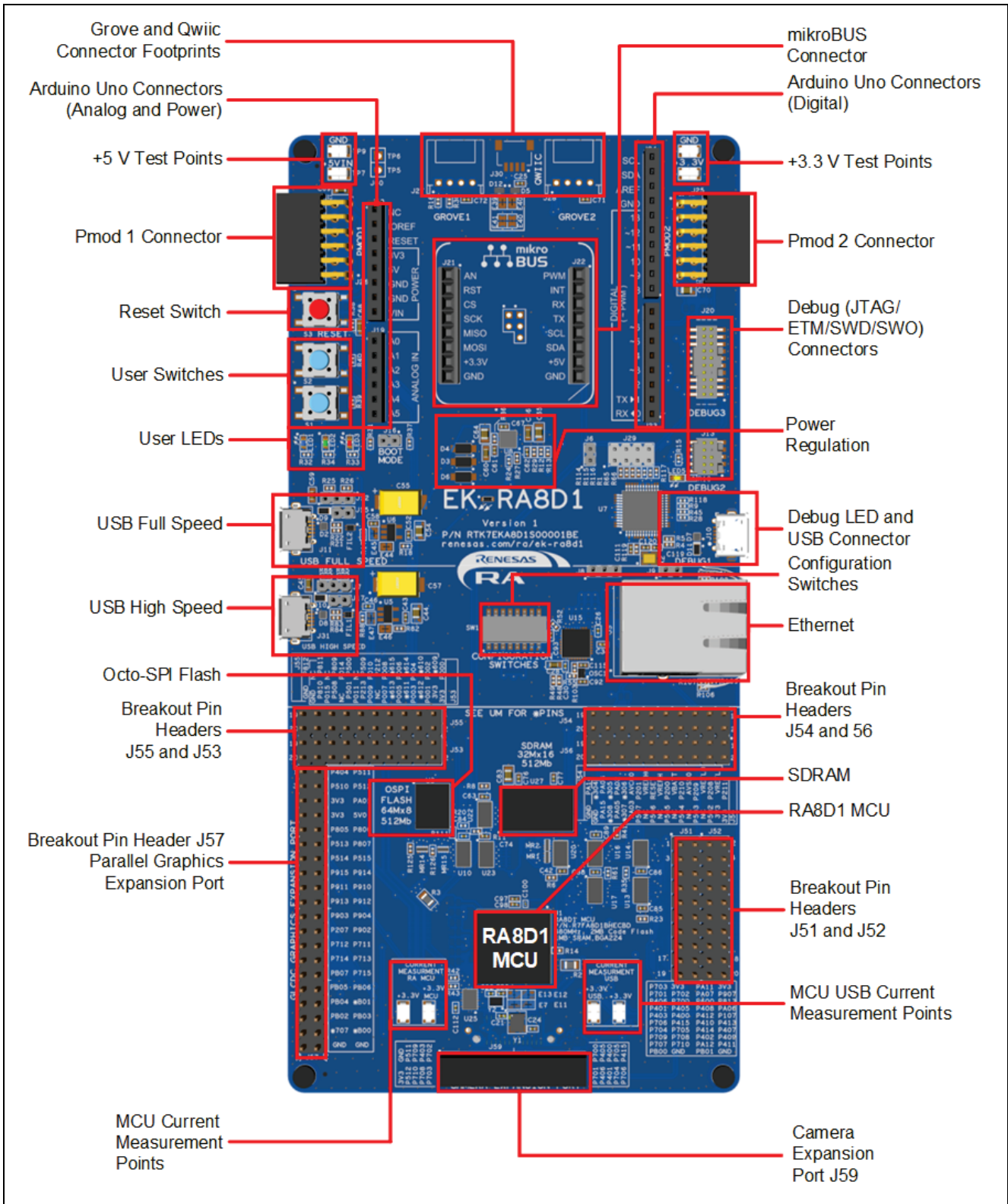

Figure 1. EK-RA8D1 Board Top Side

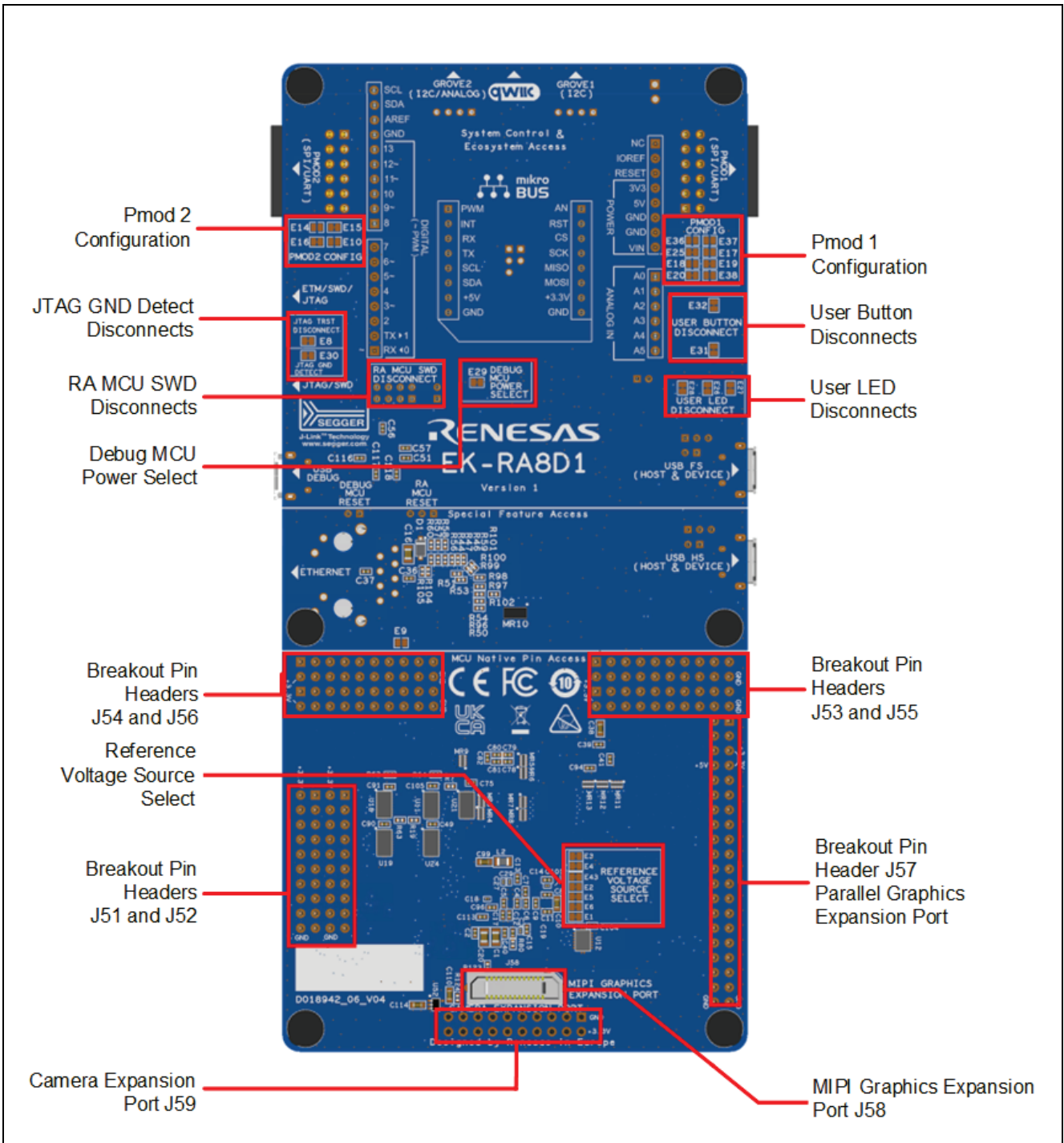

Figure 2. EK-RA8D1 Board Bottom Side

The key features of the included expansion boards are as follows:

#### MIPI Graphics Expansion Board

- 4.5 Inch backlit TFT display, 16.7M display colors
- 480 x 854 pixels resolution
- 2-lane MIPI interface
- Capacitive touch overlay (I<sup>2</sup>C)

#### Camera Expansion Board

- Off-the-shelf Arducam CMOS OV3640 Camera Module
- ¼ Inch 3.1 Megapixel image sensor
- Up to 15 fps in QXGA (2048x1536 pixels) resolution

### 1.1 Assumptions and Advisory Notes

1. It is assumed that the user has a basic understanding of microcontrollers and embedded systems hardware.
2. It is recommended that the user refers to the *EK-RA8D1 Quick Start Guide* to get acquainted with the kit and the Quick Start example project that EK-RA8D1 board comes pre-programmed with.
3. Flexible Software Package (FSP) and Integrated Development Environment (IDE) such as e<sup>2</sup> studio are required to develop embedded applications on EK-RA8D1 kit.
4. Instructions to download and install software, import example projects, build them and program the EK-RA8D1 board are provided in the quick start guide.
5. The MCU fitted to the EK board may not contain the latest version of the on-chip boot firmware.

## 2. Kit Contents

The following components are included in the kit:

1. EK-RA8D1 v1 board
2. Micro USB device cable (type-A male to micro-B male)
3. Micro USB host cable (type-A female to micro-B male)
4. Ethernet patch cable
5. Camera Expansion Board
6. MIPI Graphics Expansion Board
7. Nylon mounting stands (4x long, 2x short), nylon screws (6x)

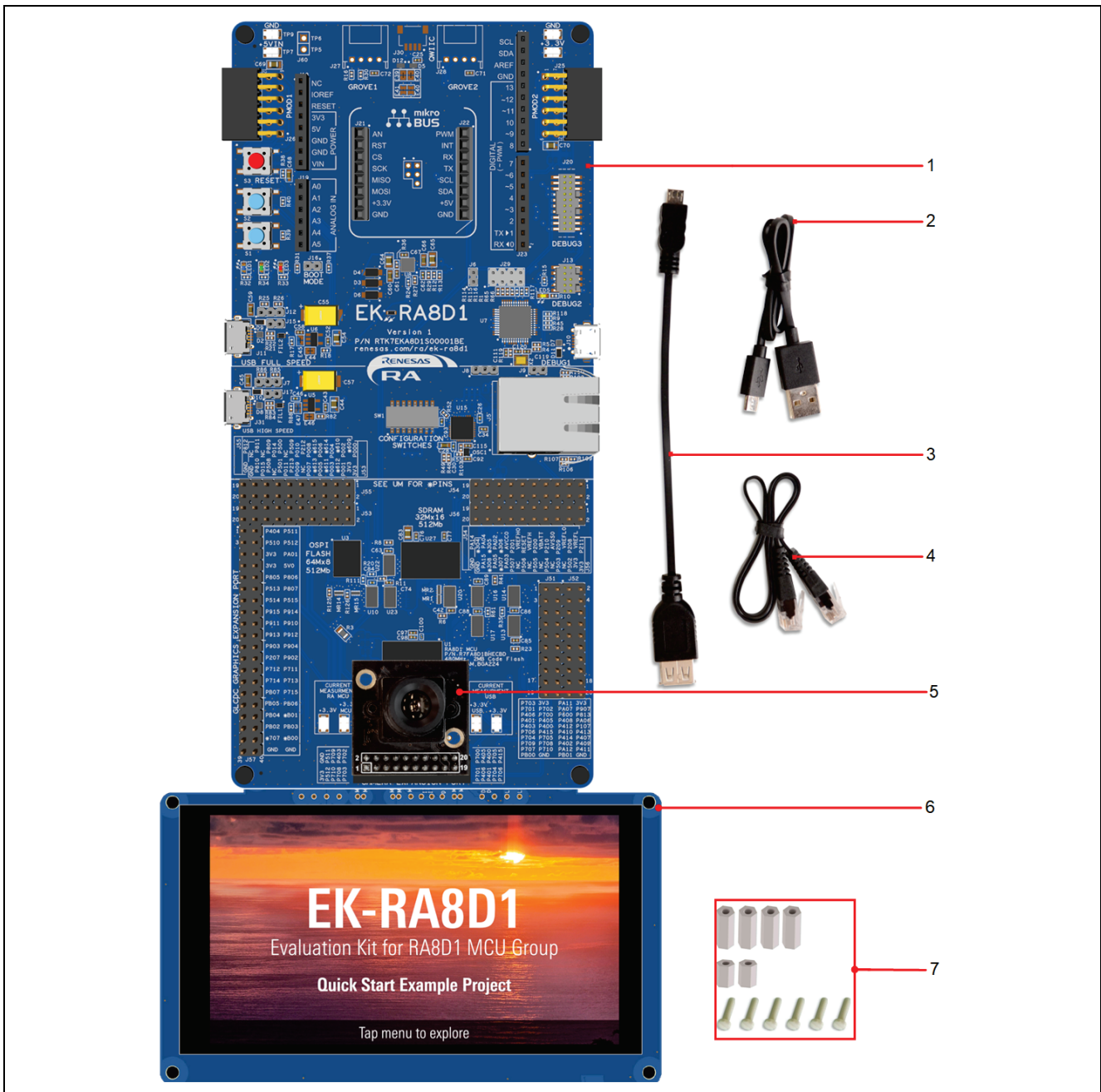

Figure 3. EK-RA8D1 Kit Contents

### 3. Ordering Information

- EK-RA8D1 v1 kit orderable part number: RTK7EKA8D1S01001BE

Notes: 1. The underlined character in the orderable part number represents the kit version.

2. The MIPI Graphics Expansion Board part number: RTKMIPILCDB00000BE.

3. The Camera Expansion Board orderable part number: ArduCam B0156

- Dimensions
  - EK-RA8D1 board: 80 mm (width) x 170 mm (length)
  - MIPI Graphics Expansion Board: 120 mm (width) x 90 mm (length)
  - Camera Expansion Board: 30.5 mm (width) x 30.5 mm (length)

### 4. Hardware Architecture and Default Configuration

#### 4.1 Kit Architecture

The EK-RA8D1 board is designed with three sections or areas to help shorten the learning curve of users and maximize the design and knowledge reuse among similar kits. The contents of these three areas are conceptually standardized among similar kits.

**Table 1. Kit Architecture**

Kit area	Area features	Area present on all similar kits	Functionality is:
MCU Native Pin Access Area	RA MCU, breakout pin headers for all MCU I/O and power, current measurement MIPI Graphics Expansion Port, Parallel Graphics Expansion Port Camera Expansion Port, Octo-SPI Flash, and SDRAM	Yes	MCU dependent
Special Feature Access Area	Configuration Switches MCU special features: Ethernet and USB High Speed Host and Device	No	MCU dependent
System Control and Ecosystem Access Area	Power, Debug MCU, User LED and buttons, reset, ecosystem connectors, USB Full Speed Host and Device, and Boot configuration	Yes	Same or similar across similar kits

**Note:** The Octo-SPI Flash and SDRAM are among the Special Feature Access features. Normally, they would be in the Special Feature Access Area, however, to optimize the layout, routing, and performance, they are placed in the MCU Native Pin Access area.

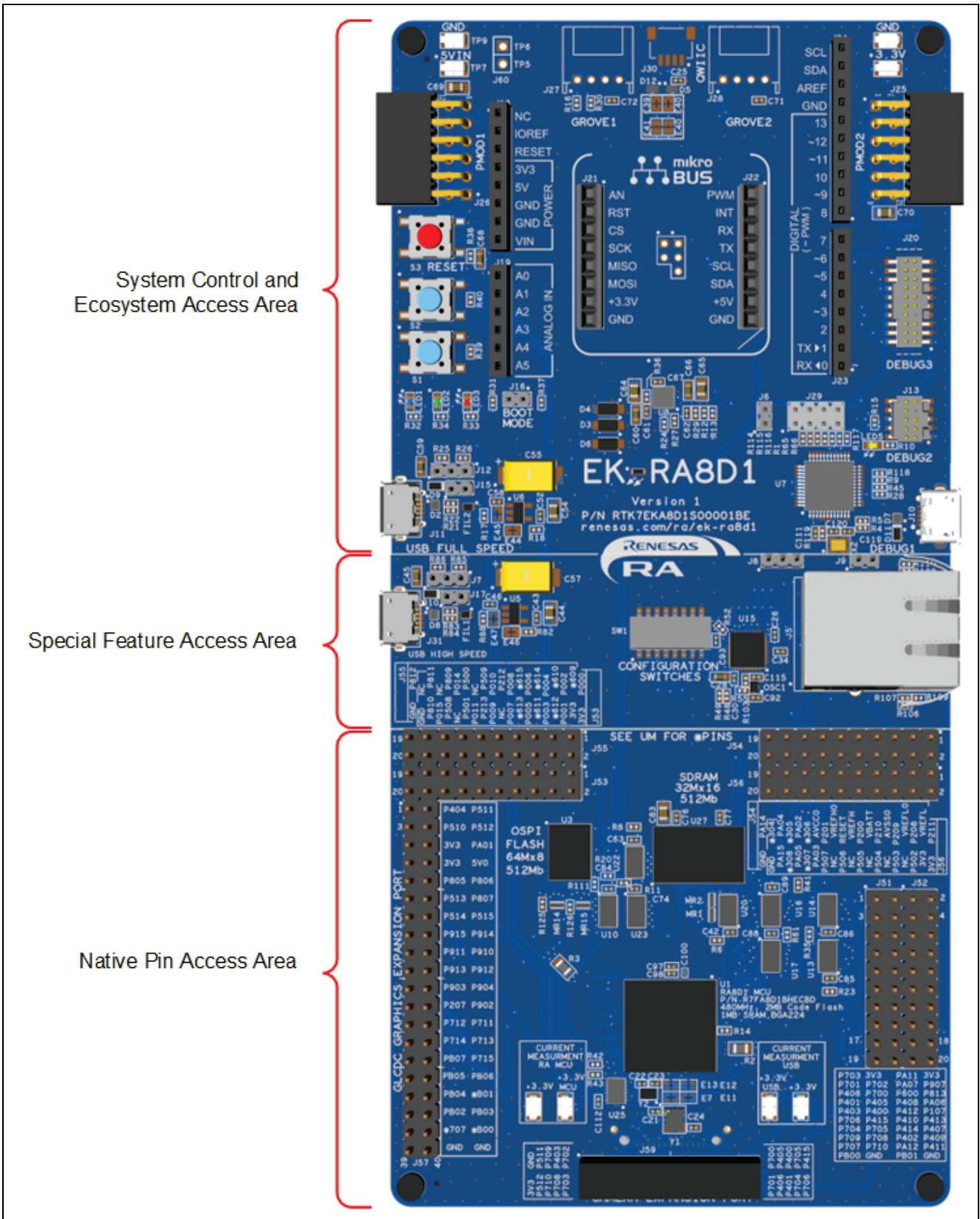

Figure 4. EK-RA8D1 Board Functional Area Definitions

4.2 System Block Diagram

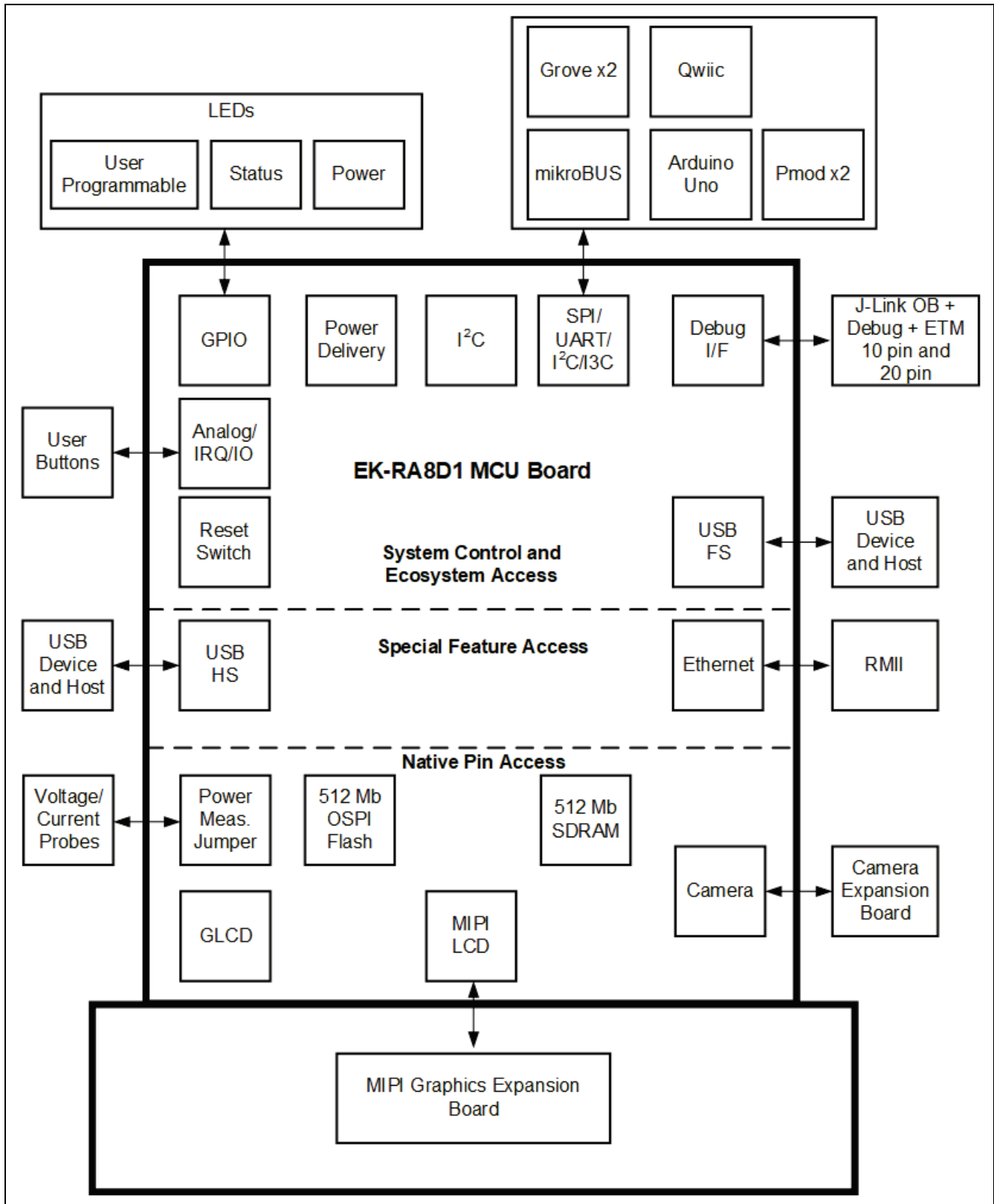

Figure 5. EK-RA8D1 Board Block Diagram



### 4.3 Jumper Configuration

Two types of jumpers are provided on the EK-RA8D1 board.

1. Copper jumpers (trace-cut type and solder bridge type)
2. Traditional pin header jumpers

The following sections describe each type and their default configuration.

#### 4.3.1 Copper Jumpers

Copper jumpers are of two types, designated **trace-cut** and **solder-bridge**.

A **trace-cut jumper** is provided with a narrow copper trace connecting its pads. The silk screen overlay printing around a trace-cut jumper is a solid box. To isolate the pads, cut the trace between pads adjacent to each pad, then remove the connecting copper foil either mechanically or with the assistance of heat. Once the etched copper trace is removed, the trace-cut jumper is turned into a solder-bridge jumper for any later changes.

A **solder-bridge** jumper is provided with two isolated pads that may be joined together by one of three methods:

- Solder may be applied to both pads to develop a bulge on each and the bulges joined by touching a soldering iron across the two pads.
- A small wire may be placed across the two pads and soldered in place.
- A SMT resistor, size 0805, 0603, or 0402, may be placed across the two pads and soldered in place. A zero-ohm resistor shorts the pads together.

For any copper jumper, the connection is considered **closed** if there is an electrical connection between the pads (default for trace-cut jumpers.) The connection is considered **open** if there is no electrical connection between the pads (default for the solder-bridge jumpers.)

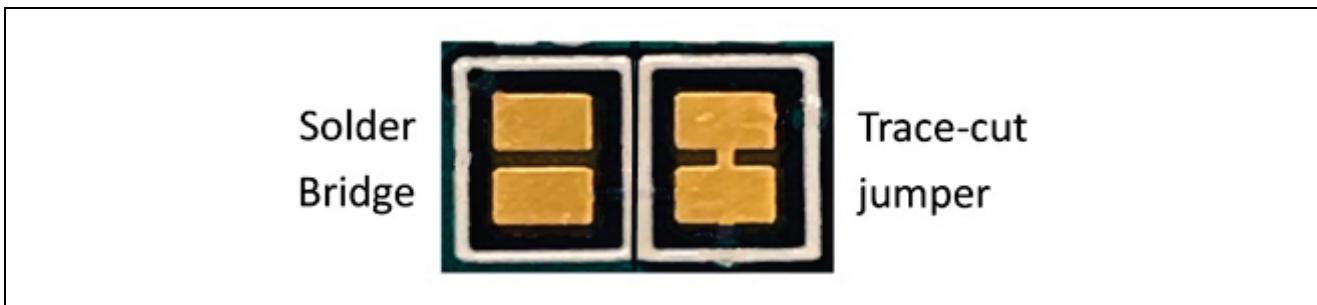

Figure 6. Copper Jumpers

#### 4.3.2 Traditional Pin Header Jumpers

These jumpers are traditional small pitch jumpers that require an external shunt to open/close them. The traditional pin jumpers on the EK-RA8D1 board are 2 mm pitch headers and require compatible 2 mm shunt jumpers.

#### 4.3.3 Default Jumper Configuration

The following table describes the default configuration for each jumper on the EK-RA8D1 board. This includes copper jumpers (Ex designation) and traditional pin jumpers (Jx designation).

The Circuit Group for each jumper is the designation found in the board schematic (available in the Design Package). Functional details for many of the listed jumpers may be found in sections associated with each functional area of the kits.

Table 2. Default Jumper Configuration

Location	Circuit Group	Default Open/Closed	Function
J6	J-Link OB	Closed	Configures J-Link OB connection to MCU mode
J8	J-Link OB	Jumper on pins 1-2	Configures the MCU for normal operation
J9	J-Link OB	Open	Configures JLOB_RESET# for on-board debugger mode
J29	J-Link OB	Jumper on pins 1-2	Connects the J-Link OB debugger to the RA MCU

Location	Circuit Group	Default Open/Closed	Function
		Jumper on pins 3-4 Jumper on pins 5-6 Jumper on pins 7-8	
J16	MCU Boot Mode	Open	Configures the MCU for normal boot mode
J12	USB FS	Jumper on pins 2-3	Sets USB FS power to device mode
J15	USB FS	Closed	Connects micro-USB power to system power
J7	USB HS	Jumper on pins 2-3	Sets USB HS power to device mode
J17	USB HS	Closed	Connects micro-USB power to system power
E1	MCU Power	Closed	Connects VREFL0 to GND
E2	MCU Power	Closed	Connects VREFH to +3.3 V
E3	MCU Power	Closed	Connects AVCC0 to +3.3 V
E4	MCU Power	Closed	Connects AVSS0 to GND
E5	MCU Power	Closed	Connects VREFL to GND
E6	MCU Power	Closed	Connects VREFH0 to +3.3 V
E8	Debug	Closed	Connects debugger JTAG_RESET# to JTAG connectors
E9	Debug	Open	Connects JTAG_RESET# from JTAG connectors to J56 pin 15
E7	MCU Clock	Closed	Connects P212/EXTAL to 20 MHz crystal
E11	MCU Clock	Closed	Connects P213/XTAL to 20 MHz crystal
E12	MCU Clock	Open	Connects P213/XTAL pin to pin headers
E13	MCU Clock	Open	Connects P212/EXTAL pin to pin headers
E26	User LED	Closed	Connects P414 to User LED2
E27	User LED	Closed	Connects P600 to User LED1
E28	User LED	Closed	Connects P107 to User LED3
E29	Debug MCU Power	Closed	Connects the Debug MCU power to +3.3 V
E30	JTAG	Closed	Connects the JTAG GND Detect pin on J20 and J13 to GND
E31	User Switch	Closed	Connects P009 to User Switch S1
E32	User Switch	Closed	Connects P008 to User Switch S2
E17	Pmod1	Open	Connects P613 (CTS0) to Pmod 1 pin1
E18	Pmod1	Open	Connects P612 (RTS0) to Pmod 1 pin4
E19	Pmod1	Closed	Connects P612 (SS0/CTS_RTS0) to Pmod 1 pin1
E20	Pmod1	Closed	Connects P611 (SCK0) to Pmod 1 pin4
E25	Pmod1	Closed	Connects +3.3 V to Pmod 1
E36	Pmod1	Open	Connects +5.0 V to Pmod 1
E37	Pmod1	Open	Connects P512 (SCL1) to Pmod 1
E38	Pmod1	Open	Connects P511 (SDA1) to Pmod 1
E10	Pmod2	Open	Connects PA06 (CTS2) to Pmod 2 pin 1
E14	Pmod2	Open	Connects PA05 (RTS2) to Pmod 2 pin 4
E15	Pmod2	Closed	Connects PA05 (SS2/CTS_RTS2) to Pmod 2 pin1
E16	Pmod2	Closed	Connects PA04 (SCK2/RTS2) to Pmod 2 pin 4
E39	Grove 2	Closed	Connects I3C SCL to Grove 2
E40	Grove 2	Closed	Connects I3C SDA to Grove 2
E41	Grove 2	Open	Connects P002 (AN102) to Grove 2
E42	Grove 2	Open	Connects P005 (AN001) to Grove 2
E43	Arduino	Closed	Connects VREFH to the Arduino AREF pin
E44	USBFS	Closed	Connects P500 to the VBUS power supply enable pin for USB Full Speed

Location	Circuit Group	Default Open/Closed	Function
E45	USBFS	Closed	Connects P501 to the USB VBUS Fault signal for USB Full Speed
E46	USBHS	Closed	Connects PB00 to the VBUS power supply enable pin for USB High Speed
E47	USBHS	Closed	Connects P707 to the USB OVRCURA for USB High Speed

#### 4.3.4 Default Switch Configuration

The following table describes the function and default configuration for each switch that selects the operational peripheral pins on the EK-RA8D1 board.

The Circuit Group for each switch is the designation found in the board schematic (available in the Design Package). Functional details for many of the listed switches may be found in sections associated with each functional area of the kits.

**Table 3. Default Switch Configuration (SW1)**

Location	Circuit Group	Default ON/Off	Function / Restrictions
SW1-1	Pmod 1	Off	Pmod 1 connectivity conflicts with SDRAM
SW1-2	DEBUG TRACE	Off	TRACE connectivity conflicts with ETH-A and SDRAM
SW1-3	CAMERA	<b>ON</b>	CAMERA conflicts with ETH-B and I3C
SW1-4	ETHERNET A	Off	ETH-A conflicts with ETH-B, TRACE and SDRAM
SW1-5	ETHERNET B	Off	ETH-B conflicts with ETH-A, CAMERA and I3C
SW1-6	GLCD (not MIPI)	Off	GLCD conflicts with USB-HS
SW1-7	SDRAM	<b>ON</b>	SDRAM conflicts with TRACE, ETH-A and Pmod 1
SW1-8	I3C	Off	I3C conflicts with ETH-B and CAMERA

**Table 4. Permitted Switch Configuration (SW1)**

**IMPORTANT: Ensure that invalid switch configuration is not made to avoid potential failures**

SWITCH S1	SW1-1 Pmod 1	SW1-2 TRACE	SW1-3 CAMERA	SW1-4 ETH-A	SW1-5 ETH-B	SW1-6 GLCD	SW1-7 SDRAM	SW1-8 I3C	USB-HS
SW1-1 Pmod 1	-	OK	OK	OK	OK	OK	<b>NO</b>	OK	OK
SW1-2 TRACE	OK	-	OK	<b>NO</b>	OK	OK	<b>NO</b>	OK	OK
SW1-3 CAMERA	OK	OK	-	OK	<b>NO</b>	OK	OK	<b>NO</b>	OK
SW1-4 ETH-A	OK	<b>NO</b>	OK	-	<b>NO</b>	OK	<b>NO</b>	OK	OK
SW1-5 ETH-B	OK	OK	<b>NO</b>	<b>NO</b>	-	OK	OK	<b>NO</b>	OK
SW1-6 GLCD	OK	OK	OK	OK	OK	-	OK	<b>NO</b>	<b>NO</b>
SW1-7 SDRAM	<b>NO</b>	<b>NO</b>	OK	<b>NO</b>	OK	OK	-	OK	OK
SW1-8 I3C	OK	OK	<b>NO</b>	OK	<b>NO</b>	<b>NO</b>	OK	-	OK
USB-HS	OK	OK	OK	OK	OK	<b>NO</b>	OK	OK	-

### 5. System Control and Ecosystem Access Area

The following figure shows the System Control and Ecosystem Access area on the EK-RA8D1 board. Subsequent sections detail the features and functionality provided in the area.

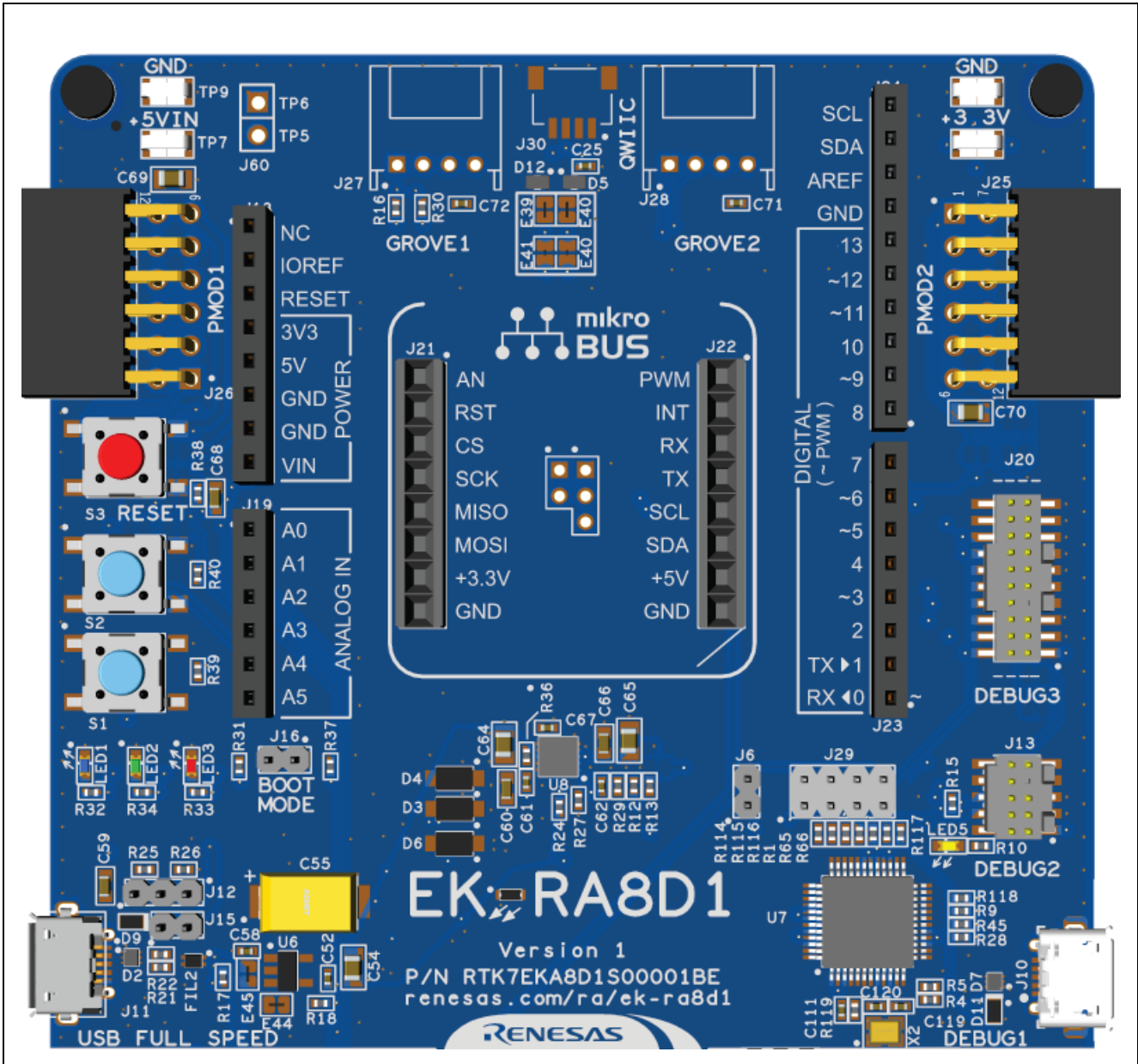

Figure 7. System Control and Ecosystem Access Area

## 5.1 Power

The EK-RA8D1 kit is designed for +5 V operation. An on-board Low Dropout Regulator (LDO) is used to convert the 5 V supply to a 3.3 V supply. The 3.3 V supply is used to power the RA MCU and other peripheral features.

### 5.1.1 Power Supply Options

This section describes the different ways in which EK-RA8D1 kit can be powered.

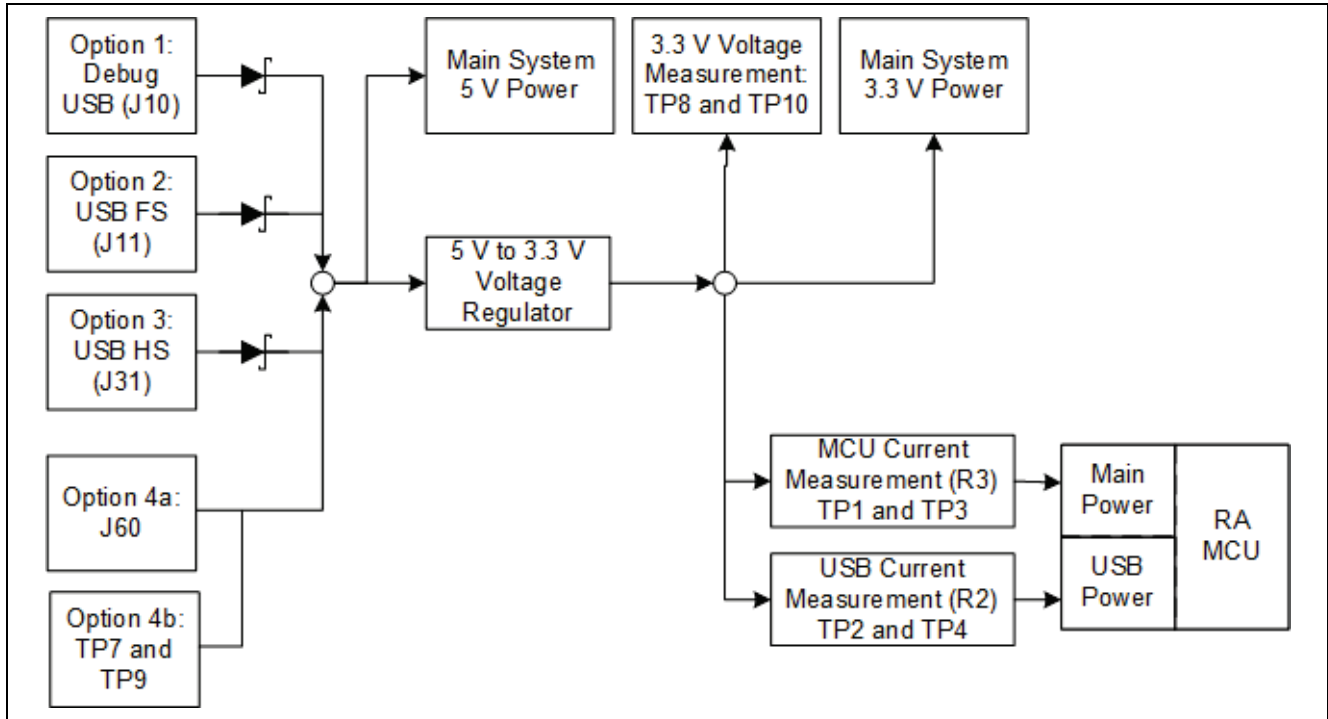

Figure 8. Power Supply Options

#### 5.1.1.1 Option 1: Debug USB

5 V may be supplied from an external USB host to the USB Debug connector (J10) labelled DEBUG on the board. Power from this source is connected to the main system 5 V power. Reverse current protection is provided between this connector and the main system 5 V power.

#### 5.1.1.2 Option 2: USB Full Speed

5 V may be supplied from an external USB host to the USB Full Speed connector (J11) labelled USB FULL SPEED on the board. Power from this source is connected to the main system 5 V power. Reverse current protection is provided between this connector and the main system 5 V power.

#### 5.1.1.3 Option 3: USB High Speed

5 V may be supplied from an external USB host to the USB High Speed connector (J31) labelled USB HIGH SPEED on the board. Power from this source is connected to the main system 5 V power. Reverse current protection is provided between this connector and the main system 5 V power.

### 5.1.1.4 Option 4: 5 V Test Points

5 V may be supplied from an external power supply to test points on the board. TP7 (5 V) and TP9 (GND) are loop-style test points, and J60 provides large via style test points that can accommodate a 0.1" pin header or connector. The two types of test points are electrically equivalent, and both are provided for user convenience. Power from this source is connected to the main system 5 V power. These test points can be found at the top left of the board above Pmod1.

Please note that reverse current protection is not provided when the device is powered using this option. Please ensure that any source connected has reverse current protection on its own.

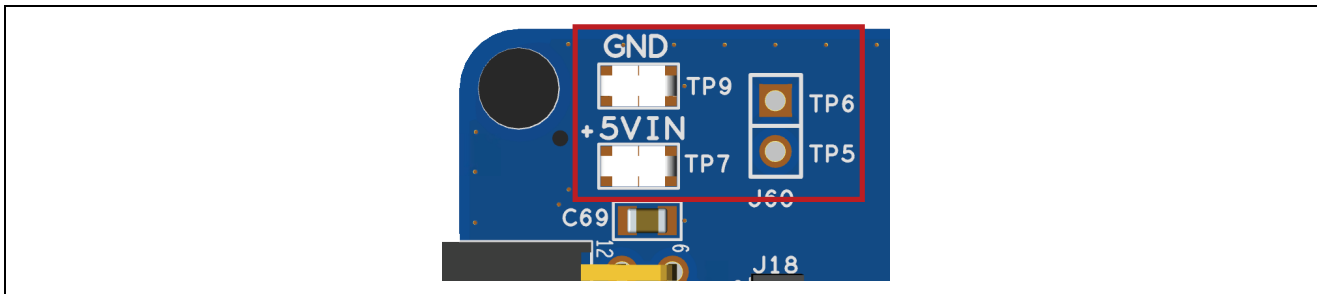

Figure 9. Test Point Location

### 5.1.2 Power Supply Considerations

The on-board LDO regulator which supplies +3.3 V has a built-in current limit of 2.0 A. Make sure the total current required by the RA MCU, any active on-board features, and any connected peripheral devices does not exceed this limit.

Note: The total current available from a typical enumerated USB host is 500 mA maximum. Depending on the configuration of the kit, multiple power sources may be required.

### 5.1.3 Power-up Behavior

When powered, the white LED near the center of the board (the “dash” in the EK-RA8D1 name) will light up. For more details on initial power up behavior, see the *EK-RA8D1 Quick Start Guide*.

## 5.2 Debug and Trace

The EK-RA8D1 board supports the following three debug modes.

Table 5. Debug Modes

Debug Modes	Debugger MCU (the device that connects to the IDE on PC)	Target MCU (the device that is being debugged)	Debugging Interface/Protocol	Connector Used
Debug on-board	RA4M2 (on-board)	RA8D1 (on-board)	SWD, JTAG	Micro USB (J10)
Debug in	External debugging tools	RA8D1 (on-board)	SWD, SWO ,ETM, JTAG,	20-pin connector (J20) or 10-pin connector (J13)
Debug out	RA4M2 (on-board)	Any external RA MCU	SWD, SWO, JTAG	Micro USB (J10) plus either 20-pin connector (J20) or 10-pin connector (J13)

Notes:

- See Table 7 for the Debug USB connector pin definition.
- See Table 10 for the 20-pin JTAG connector pin definition.
- See Table 11 for the 10-pin JTAG connector pin definition.

The following table summarizes the jumper configuration for each of the debug modes.

**Table 6. Jumper Connection Summary for Different Debug Modes**

Debug Modes	J6	J8	J9	J29
Debug on-board	Closed	Jumper on pins 1-2	Open	Jumpers on pins 1-2, 3-4, 5-6, 7-8
Debug in	Closed	Jumper on pins 1-2	Closed	Jumpers on pins 1-2, 3-4, 5-6, 7-8
Debug out	Open	Jumper on pins 2-3	Open	All pins open

### 5.2.1 Debug On-Board

The on-board debug functionality is provided using Renesas RA4M2 Debug MCU and SEGGER J-Link® firmware. Debug USB Micro-B connector (J10) connects the RA4M2 Debug MCU to an external USB Full Speed Host, allowing re-programming and debugging of the target RA MCU firmware. This connection is the default debug mode for the EK-RA8D1 board.

The RA4M2 Debug MCU connects to the target RA MCU using the SWD interface or the JTAG interface.

**Table 7. Debug USB Port Assignments**

Debug USB Port Assignments		EK-RA8D1
Pin	Description	Signal/Bus
J10-1	+5VDC	+5V_USB_DBG
J10-2	Data-	USB_JLOB_N (U7-14)
J10-3	Data+	USB_JLOB_P (U7-15)
J10-4	USB ID, jack internal switch, cable inserted	N.C.
J10-5	Ground	GND

A yellow indicator, LED5, shows the visual status of the debug interface. When the EK-RA8D1 board is powered on, and LED5 is blinking, it indicates that the RA4M2 Debug MCU is not connected to a programming host. When LED5 is on solid, it indicates that the RA4M2 Debug MCU is connected to a programming interface.

To configure the EK-RA8D1 board to use the Debug On-Board mode, configure the jumpers using the following table.

**Table 8. Debug On-Board Jumper Configuration**

Location	Default Open/Closed	Function
J6	Closed	Target RA MCU MD connected to debug
J8	Jumper on pins 1-2	Target RA MCU RESET# connected to debug RESET#
J9	Open	RA4M2 Debug MCU in normal operation mode
J29	Jumpers on pins 1-2, 3-4, 5-6, 7-8	Target RA MCU debug signals connected to the debug interface

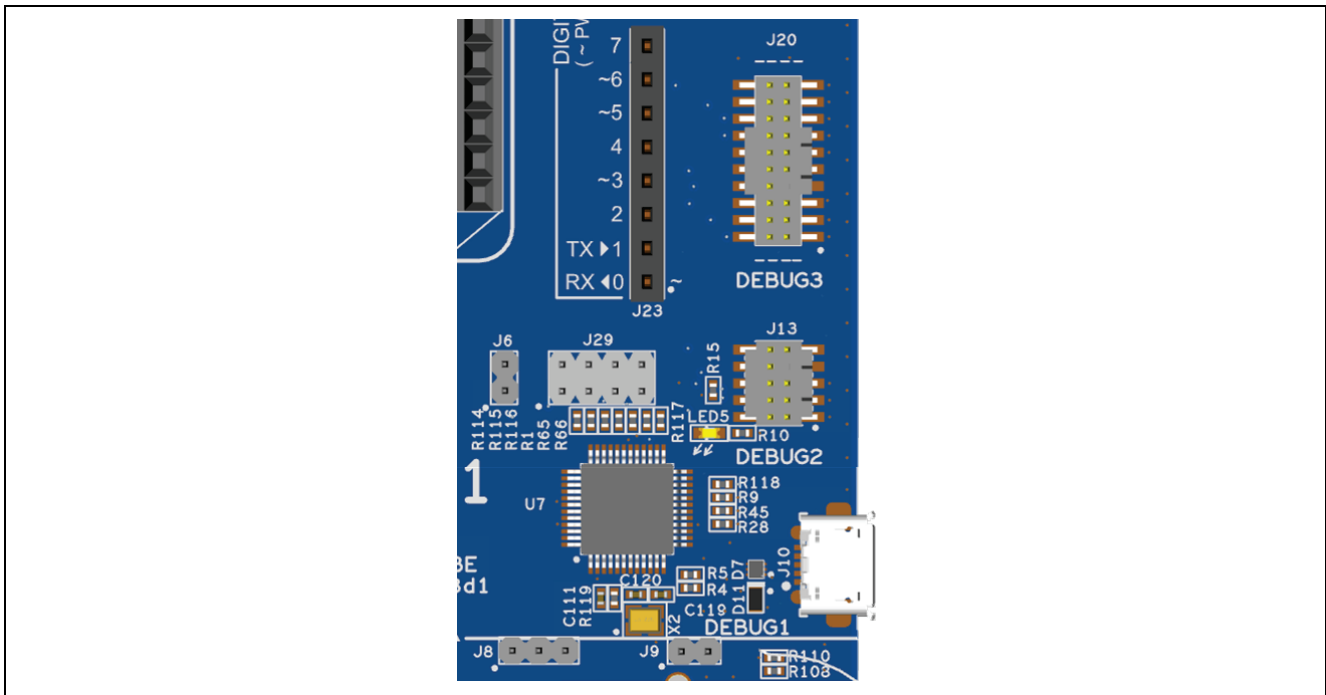

Figure 10. EK-RA8D1 Debug Interface

### 5.2.2 Debug In

One 20-pin Cortex® Debug Connector at J20 supports JTAG, SWD, SWO and ETM (TRACE) debug. One 10-pin Cortex® Debug Connector at J13 supports JTAG, SWD and SWO. Either of these connectors may be used for external debug of the target RA MCU.

To configure the EK-RA8D1 board to use the Debug In mode, configure the jumpers as shown in Table 9.

Table 9. Debug In Mode Jumper Configuration

Location	Default Open/Closed	Function
J6	Closed	Target RA MCU MD connected to debug
J8	Jumper on pins 1-2	Target RA MCU RESET# connected to debug RESET#
J9	Closed	RA4M2 Debug MCU is held in RESET
J29	Jumpers on pins 1-2, 3-4, 5-6, 7-8	Target RA MCU debug signals connected to the debug interface

Table 10. JTAG/SWO/SWD/ETM Debug Port Assignments

JTAG Port Assignments				EK-RA8D1
Pin	JTAG Pin Name	SWD Pin Name	ETM Pin Name	Signal/Bus
J20-1	Vtref	Vtref	Vtref	+3V3
J20-2	TMS	SWDIO	TMS / SWDIO	P210/SWDIO/TMS
J20-3	GND	GND	GND	GND
J20-4	TCK	SWCLK	TCK / SWCLK	P211/SWCLK/TCK
J20-5	GND	GND	GND	GND
J20-6	TDO	SWO	TDO / SWO	P209/SWO/TDO
J20-7	Key	Key	Key	N.C.
J20-8	TDI	N/A	TDI / N/A	P208/TDI
J20-9	GNDDetect	GNDDetect	GNDDetect	GND (cut E30 to open)
J20-10	nSRST	nSRST	nSRST	RESET#
J20-11	GND	GND	GND	GND
J20-12	N/A	N/A	TCLK	P308/TCLK*
J20-13	GND	GND	GND	GND
J20-14	N/A	N/A	TDATA0	P307/TDATA0*
J20-15	GND	GND	GND	GND



JTAG Port Assignments				EK-RA8D1
Pin	JTAG Pin Name	SWD Pin Name	ETM Pin Name	Signal/Bus
J20-16	N/A	N/A	TDATA1	P306/TDATA1*,**
J20-17	GND	GND	GND	GND
J20-18	N/A	N/A	TDATA2	P305/TDATA2*
J20-19	GND	GND	GND	GND
J20-20	N/A	N/A	TDATA3	P304/TDATA3*

\* Option selection by SW1-2

\*\* Option to isolate with E9

**Table 11. JTAG/SWO/SWD Debug Port Assignments**

JTAG Port Assignments			EK-RA8D1
Pin	JTAG Pin Name	SWD Pin Name	Signal/Bus
J13-1	Vtref	Vtref	+3V3
J13-2	TMS	SWDIO	P210/SWDIO/TMS
J13-3	GND	GND	GND
J13-4	TCK	SWCLK	P211/SWCLK/TCK
J13-5	GND	GND	GND
J13-6	TDO	SWO	P209/SWO/TDO
J13-7	Key	Key	N.C.
J13-8	TDI	N/A	P208/TDI
J13-9	GNDDetect	GNDDetect	GND (cut E30 to open)
J13-10	nSRST	nSRST	RESET#

Note: The Cortex® Debug Connector is fully described in the Arm® CoreSight™ Architecture Specification.

### 5.2.3 Debug Out

The EK-RA8D1 board can be configured to use the RA4M2 Debug MCU to debug target RA MCU on an external board.

A yellow indicator, LED5, shows the visual status of the debug interface. When the EK-RA8D1 board is powered on, and LED5 is blinking, this indicates that the RA4M2 Debug MCU is not connected to a programming host. When LED5 is on solid, this indicates that the RA4M2 Debug MCU is connected to a programming interface. When the debug interface is actively in use, the LED will flicker randomly.

To configure the EK-RA8D1 board to use the Debug Out mode, configure the jumpers according to the following table.

**Table 12. Debug Out Jumper Configuration**

Location	Default Open/Closed	Function
J6	Open	No connection to RA MCU
J8	Jumper on pins 2-3	On-board RA MCU is held in RESET
J9	Open	RA4M2 Debug MCU in normal operation mode
J29	All jumpers removed	Disconnects the on-board RA MCU debug signals from the Debug Interface

## 5.3 Ecosystem

The System Control and Ecosystem area provides users the option to simultaneously connect several third-party add-on modules compatible with five most popular ecosystems using the following connectors:

1. Two Seeed Grove® system (I<sup>2</sup>C/I<sup>3</sup>C/Analog) connectors (not populated)
2. One SparkFun® Qwiic® connector (not populated)
3. Two Digilent Pmod™ (SPI, UART and I<sup>2</sup>C) connectors
4. Arduino™ (Uno R3) connector
5. MikroElektronika™ mikroBUS connector

### 5.3.1 Seeed Grove® Connectors

#### 5.3.1.1 Grove 1

A Seeed Grove I<sup>2</sup>C connector footprint is provided at J27. The RA MCU acts as a two-wire serial master, and a connected module acts as a two-wire serial slave.

**Table 13. Grove 1 Port Assignments**

Grove 1 Connector		EK-RA8D1
Pin	Description	Signal/Bus
J27-1	SCL	P512 (SCL1)
J27-2	SDA	P511 (SDA1)
J27-3	VCC	+3.3 V
J27-4	GND	GND

#### 5.3.1.2 Grove 2

A Seeed Grove I<sup>3</sup>C connector footprint is provided at J28. The RA MCU acts as a two-wire serial master, and a connected module acts as a two-wire serial slave.

Option links E39, E40, E41 and E42 provide the capability to convert this connector to an analog Seeed Grove implementation.

**Table 14. Grove 2 Port Assignments**

Grove 2 Connector		EK-RA8D1	
Pin	Description	Signal/Bus	
J28-1	I3C_SCL	P400 (SCL0) * <sup>1</sup>	P005(AN001) * <sup>2</sup>
J28-2	I3C_SDA	P401 (SDA0) * <sup>1</sup>	P002(AN102) * <sup>2</sup>
J28-3	VCC	+3.3 V	
J28-4	GND	GND	

\*<sup>1</sup> Option selection by SW1-8

\*<sup>2</sup> Jumpers E39 and E40 are open, E41 and E42 are closed

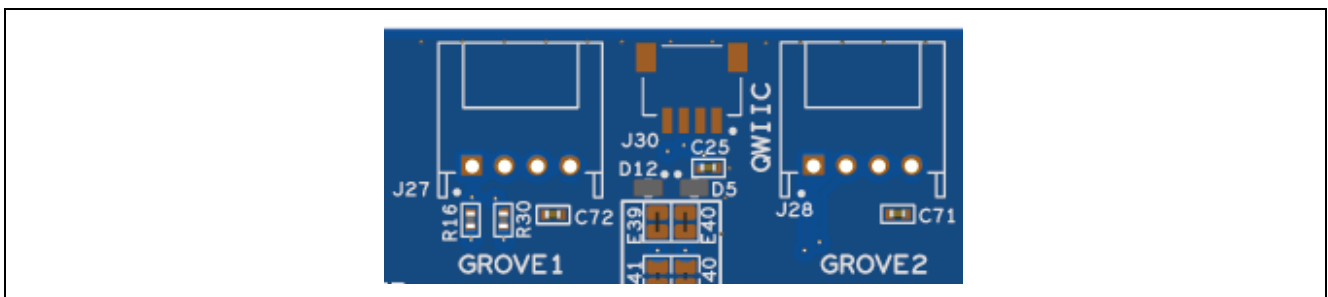

**Figure 11. Seeed Grove and SparkFun Qwiic® Connector Footprints**

### 5.3.2 SparkFun Qwiic® Connector

A SparkFun Qwiic connector footprint is provided at J30. The main MCU acts as a two-wire serial master, and a connected module acts as a two-wire serial slave (data lines shared with Grove 2).

**Table 15. Qwiic Port Assignments**

Qwiic Connector		EK-RA8D1
Pin	Description	Signal/Bus
J30-1	GND	GND
J30-2	VCC	+3.3 V
J30-3	SDA	P400 (SCL0)*
J30-4	SCL	P401 (SDA0)*

\* Option selection by SW1-8

\* Note: The SDA and SCL connections are incorrectly swapped compared to the SparkFun Qwiic definition. Please manage the connection swap by modifying the cable.

### 5.3.3 Diligent Pmod™ Connectors

Two 12-pin connectors are provided to support Pmod modules where the RA MCU acts as the master, and the connected module acts as a slave device.

These interfaces may be configured in firmware to support several Pmod types such as Type-2A (expanded SPI) and Type-3A (expanded UART).

The EK-RA8D1 board also provides solder links so the 12-pin connector may alternatively be used for Pmod Type-6A (I<sup>2</sup>C).

The default 12-pin Pmod interface supports +3.3 V devices. Please ensure that any Pmod device installed is compatible with a +3.3 V supply\*.

Note: Both Pmods use the SCI peripheral in “Simple SPI” mode, and so do not offer the full functionality of the SPI peripheral. Please see the hardware manual for full details of the SCI “Simple SPI” mode.

#### 5.3.3.1 Pmod 1

A 12-pin Pmod connector is provided at J26, Pmod 1.

This Pmod connector is controlled by a switch option (SW1-1) as the signals needed are shared with the SDRAM. Pmod 1 and SDRAM cannot be used concurrently.

**Table 16. Pmod 1 Port Assignments**

Pmod 1 Connector				EK-RA8D1	Pmod 1 Configuration	
Pin	Option Type-2A (SPI) <sup>*1</sup>	Option Type-3A (UART) <sup>*1</sup>	Option Type-6A (I <sup>2</sup> C) <sup>*1</sup>	Signal/Bus	Short	Open
J26-1	SS			P612 (SS0)	E19	E17, E18
		CTS		P613 (CTS0)	E17	E19, E18
J26-2	MOSI	TXD		P609 (MOSI0/TXD0)		
J26-3	MISO	RXD		P610 (MISO0/RXD0)		E37
			SCL <sup>*2</sup>	P512 (SCL1)	E37	
J26-4	SCK			P611 (SCK0)	E20	E18, E38
		RTS0		P612 (RTS0)	E18	E20, E38
			SDA <sup>*2</sup>	P511 (SDA1)	E38	E18, E20
J26-5	GND			GND		
J26-6	VCC			+3.3 V	E25	E36
				+5.0 V	E36	E25
J26-7	IRQ			P006 (IRQ11)		
J26-8	RESET (master to slave)			PA12		
J26-9	GPIO			P614		
J26-10	GPIO			P615		
J26-11	GND			GND		
J26-12	VCC			+3.3 V	E25	E36
				+5.0 V	E36	E25

<sup>\*1</sup> If using Option Type-2A (SPI) or Type-3A (UART), SW1-1 is on.

If using Option Type-6A (I<sup>2</sup>C), SW1-1 is off.

<sup>\*2</sup> Option selection by SW1-8

Caution: 5 V optional supply is provided (J26-6 and J26-12), however the interface must only be driven with 3.3 V signals from the Pmod 1. The EK-RA8D1 will only provide 3.3 V signal levels to the Pmod 1.

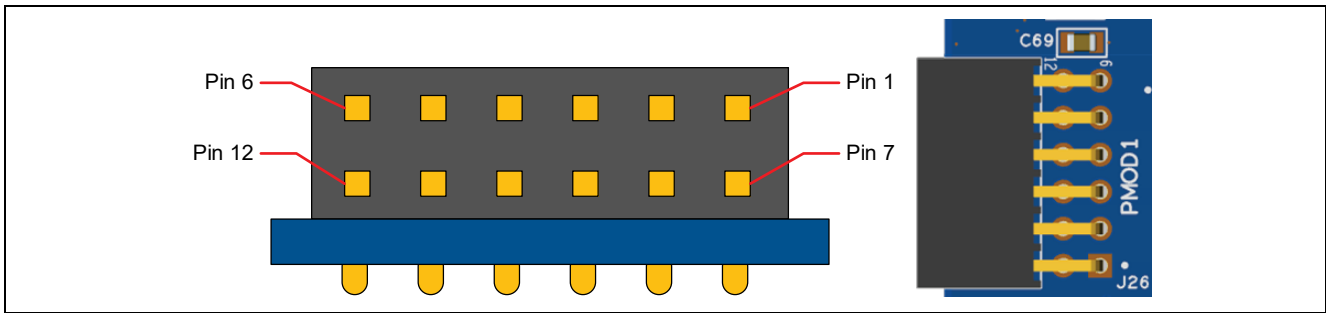

Figure 12. Pmod 1 Connector

5.3.3.2 Pmod 2

A 12-pin Pmod connector is provided at J25, Pmod 2.

Table 17. Pmod 2 Port Assignments

Pmod 2 Connector			EK-RA8D1	Pmod 2 Configuration	
Pin	Option Type-2A (SPI)	Option Type-3A (UART)	Signal/Bus	Short	Open
J25-1	SS		PA05 (SS2)	E15	E10
J25-1		CTS	PA06 (CTS2)	E10	E15
J25-2	MOSI	TXD	PA03 (MOSI2/TXD2)		
J25-3	MISO	RXD	PA02 (MISO2/RXD2)		
J25-4	SCK		PA04 (SCK2)	E16	E14
J25-4		RTS	PA05 (RTS2)	E14	E16
J25-5	GND		GND		
J25-6	VCC		+3.3 V		
J25-7	IRQ		P508 (IRQ1)		
J25-8	RESET (master to slave)		P809		
J25-9	GPIO		P810		
J25-10	GPIO		P811		
J25-11	GND		GND		
J25-12	VCC		+3.3 V		

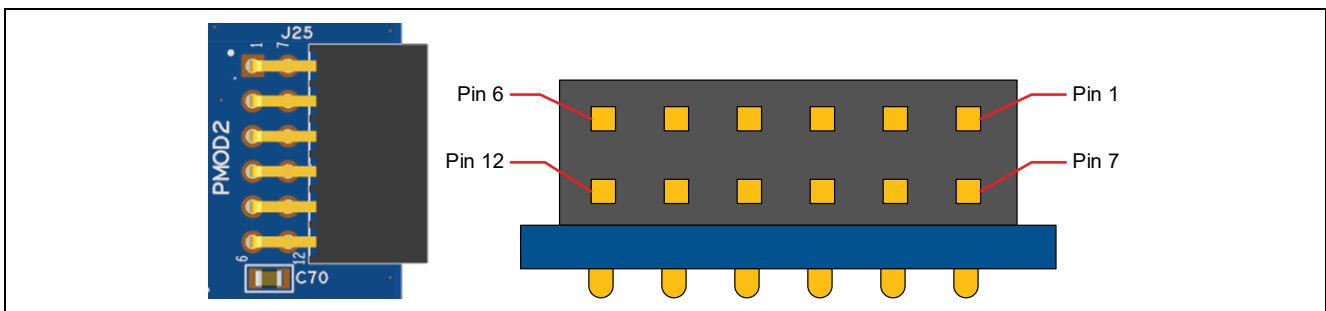

Figure 13. Pmod 2 Connector

5.3.4 Arduino™ Connector

Near the center of the System Control and Ecosystem Access area is an Arduino™ Uno R3 compatible connector interface.

Table 18. Arduino Uno Port Assignments

Arduino Compatible Connectors		EK-RA8D1
Pin	Description	Signal/Bus
J18-1	N.C.	N.C.
J18-2	IOREF	+3.3 V

Arduino Compatible Connectors				EK-RA8D1
Pin	Description			Signal/Bus
J18-3	RESET			P813
J18-4	3.3 V			+3.3 V
J18-5	5 V			+5 V
J18-6	GND			GND
J18-7	GND			GND
J18-8	VIN			N.C.
J19-1	A0			P004 (AN000)
J19-2	A1			P003 (AN104)
J19-3	A2			P007 (AN004)
J19-4	A3			P011 (AN106)
J19-5	A4			P014 (AN007/DA0)
J19-6	A5			P015 (AN105/DA1)
J23-1	D0	RXD	PWM	P408 (RXD3/GTIOC10A)
J23-2	D1	TXD		P409 (TXD3)
J23-3	D2	INT0		P509 (IRQ2)
J23-4	D3	INT1	PWM	P907 (IRQ10/GTIOC13A)
J23-5	D4			P506
J23-6	D5		PWM	PA11 (GTIOC6A)
J23-7	D6		PWM	PA06 (GTIOC7B)
J23-8	D7			P505
J24-1	D8			P504
J24-2	D9		PWM	PA07 (GTIOC7A)
J24-3	D10	SPI_SS		P413 (SSLA0)
J24-4	D11	SPI_MOSI	PWM	P411 (MOSIA/GTIOC9A)
J24-5	D12	SPI_MISO	PWM	P410 (MISOA/GTIOC9B)
J24-6	D13	SPI_SCK		P412 (RSPCKA)
J24-7	GND			GND
J24-8	ARDUINO_AREF			+3.3 V
J24-9	I3C_SDA			P401 (SDA0)*
J24-10	I3C_SCL			P400 (SCL0)*

\* Option selection by SW1-8

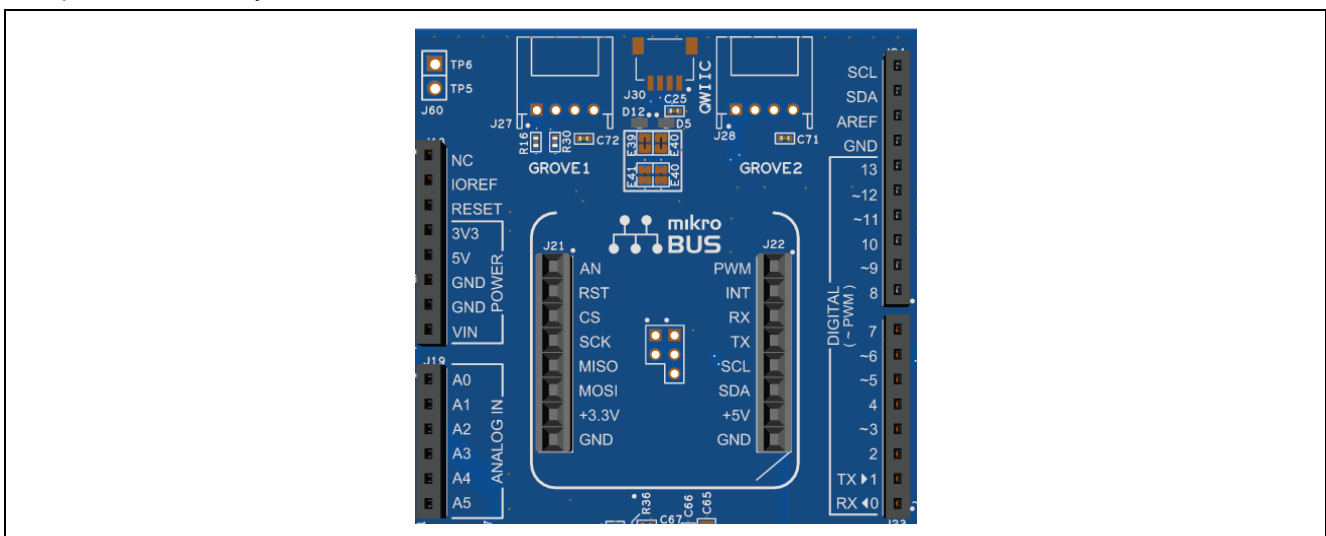

Figure 14. Arduino Uno Connectors

### 5.3.5 MikroElektronika™ mikroBUS Connector

In the center of the System Control and Ecosystem Access area is a mikroBUS compatible connector interface. This interface is compliant with mikroBUS Standard Specifications revision 2.00.

**Table 19. mikroBUS Assignments**

mikroBUS Connectors		EK-RA8D1
Pin	Description	Signal/Bus
J21-1	AN (Analog)	P004 (AN000)
J21-2	RST (Reset)	P507
J21-3	CS (SPI Chip Select)	P413 (SSLA0)
J21-4	SCK (SPI Clock)	P412 (RSPCKA)
J21-5	MISO	P410 (MISOA)
J21-6	MOSI	P411 (MOSIA)
J21-7	+3.3 V	+3.3 V
J21-8	GND	GND
J22-1	PWM	P907 (GTIOC13A)
J22-2	INT (Hardware Interrupt)	P010 (IRQ14)
J22-3	RX (UART Receive)	P408 (RXD3)
J22-4	TX (UART Transmit)	P409 (TXD3)
J22-5	SCL (I3C Clock)	P400 (SCL0)*
J22-6	SDA (I3C Data)	P401 (SDA0)*
J22-7	+5 V	+5 V
J22-8	GND	GND

\* Option selection by SW1-8

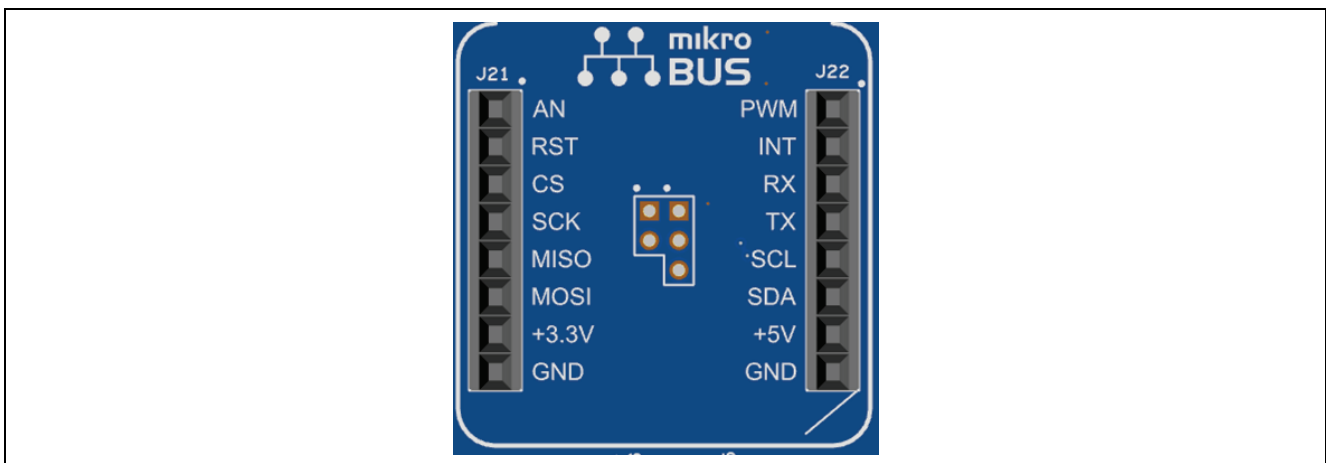

**Figure 15. mikroBUS Connector**

## 5.4 Connectivity

### 5.4.1 USB Full Speed

The USB micro-AB connection jack (J11) connects the RA MCU USB Full Speed interface to an external USB interface, allowing communications for testing and use of the RA MCU firmware. This connection can be configured as either a USB device or a USB host interface.

For a USB Device configuration, set jumper J12 to pins 2-3, install a jumper on J15 pins 1-2, and configure the RA MCU firmware to use the USB Full Speed ports in device mode. Power from an external USB Host on this connection can be used to provide power to the EK-RA8D1 board.

For a USB Host configuration, set jumper J12 to pins 1-2, remove the jumper from J15, and configure the RA MCU firmware to use the USB Full Speed ports in host mode. In this configuration, power to J11 is supplied from U6. The total current available from U6 is 500 mA. Note that the input power sources must be configured with enough power for both the EK-RA8D1 board and the USB Full Speed port in host mode. Connect the included USB type-A female to micro-B male cable to J11. USB device cables or devices can be connected to the USB Full Speed port using this cable.

**Table 20. USB Full Speed Port Assignments**

USB Full Speed Connector		EK-RA8D1
Pin	Description	Signal/Bus
J11-1	+5VDC	+5V_USBFS (Host Mode)* <sup>1</sup> P407/USB_VBUS = 2/3 of +5V_USBFS at J11* <sup>2</sup>
J11-2	DM	USBFS_N
J11-3	DP	USBFS_P
J11-4	USB ID, jack internal switch, cable inserted	N.C.
J11-5	Ground	GND

\*<sup>1</sup> When J12 is linked 1-2 and J15 is open

\*<sup>2</sup> When J12 is linked 2-3 and J15 is open

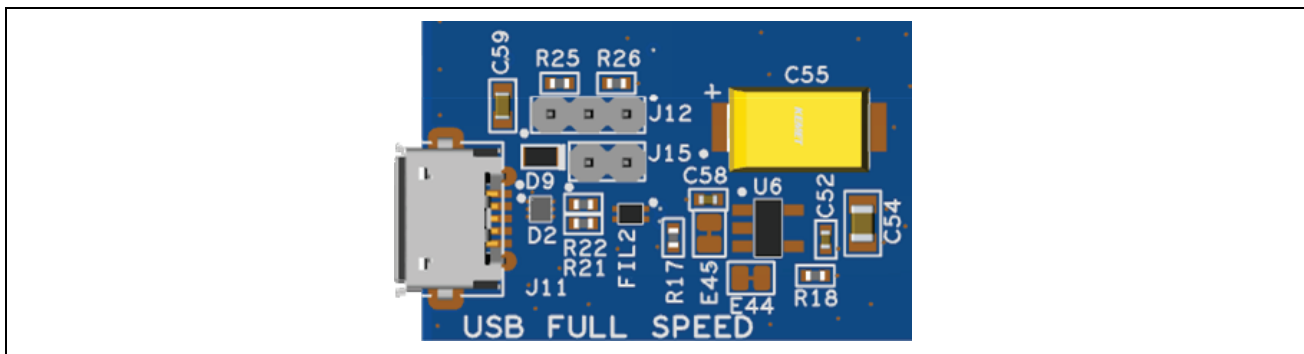

**Figure 16. USB Full Speed Connector**

### 5.4.2 I3C

The Arduino, mikroBUS, Grove 2 and Qwiic connectors connect the RA MCU I3C interface to external I3C or I<sup>2</sup>C devices allowing communications between devices.

Please ensure that SW1-8 set correctly. Set signal high to port PB02 and P711 when I3C is in use or set signal low for I<sup>2</sup>C. The required configurations can be seen in Table 21 where “x” means the configuration doesn’t matter.

**Table 21. I<sup>2</sup>C/I3C Pullup Configuration**

I <sup>2</sup> C/I3C/N.C.	SW1-8	PB02/P711
I3C	On	Low
I <sup>2</sup> C	On	High
N.C.	Off	x

## 5.5 Miscellaneous

### 5.5.1 User and Power LEDs

Five LEDs are provided on the EK-RA8D1 board. In addition, the Ethernet connector has built-in link status and link speed LEDs.

Behavior of the LEDs on the EK-RA8D1 board is described in the following table.

**Table 22. EK-RA8D1 Board LED Functions**

Designator	Color	Function	MCU Control Port
LED1	Blue	User LED	P600
LED2	Green	User LED	P414
LED3	Red	User LED	P107
LED4	White	Power on indicator	+3.3 V
LED5	Yellow	Debug LED	J-Link OB MCU

The user LEDs may be isolated from the main MCU, so the associated ports can be used for other purposes. To separate LED1 from P600, trace cut jumper E27 must be open. To separate LED2 from P414, trace cut jumper E26 must be open. To separate LED3 from P107, trace cut jumper E28 must be open.

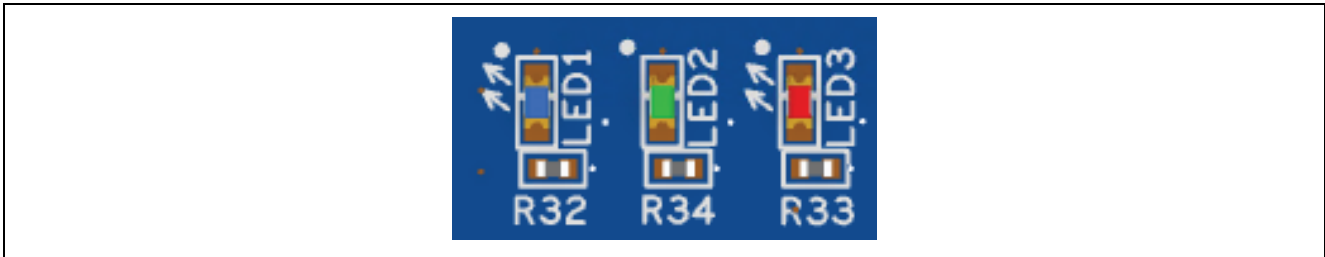

Figure 17. User LEDs



Figure 18. Power LED

### 5.5.2 User and Reset Switches

Three miniature, momentary, mechanical push-button type SMT switches are mounted on the EK-RA8D1 board.

Pressing the reset switch (S3) generates a reset signal to restart the RA MCU.

Table 23. EK-RA8D1 Board Switches

Designator	Function	MCU Control Port	Button Color
S3	MCU Reset Switch	RESET#	Red
S2	User Switch	P008 (IRQ12-DS)	Blue
S1	User Switch	P009 (IRQ13-DS)	Blue

The user switches S1 and S2 may be isolated from the main MCU, so the associated ports can be used for other purposes. To separate S1 from P009, trace cut jumper E31 must be open. To separate S2 from P008, trace cut jumper E32 must be open.

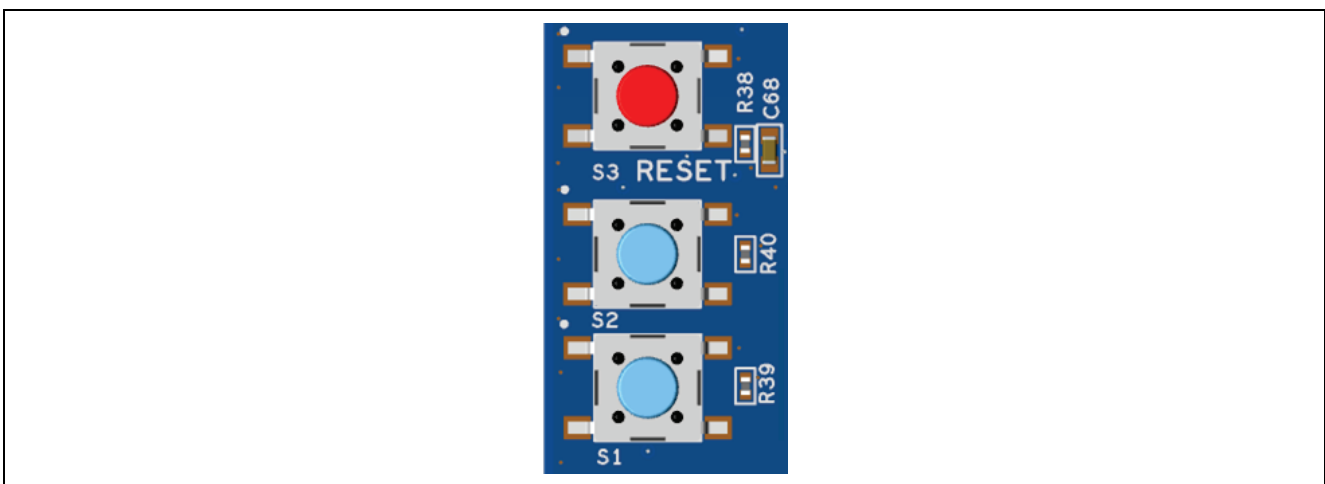

Figure 19. Reset and User Switches



### 5.5.3 MCU Boot Mode

A two-pin header (J16) is provided to select the boot mode (P201) of the RA MCU. For normal operation, or Single-Chip mode, leave J16 open. To enter SCI Boot mode or USB boot mode, place a jumper on J16.

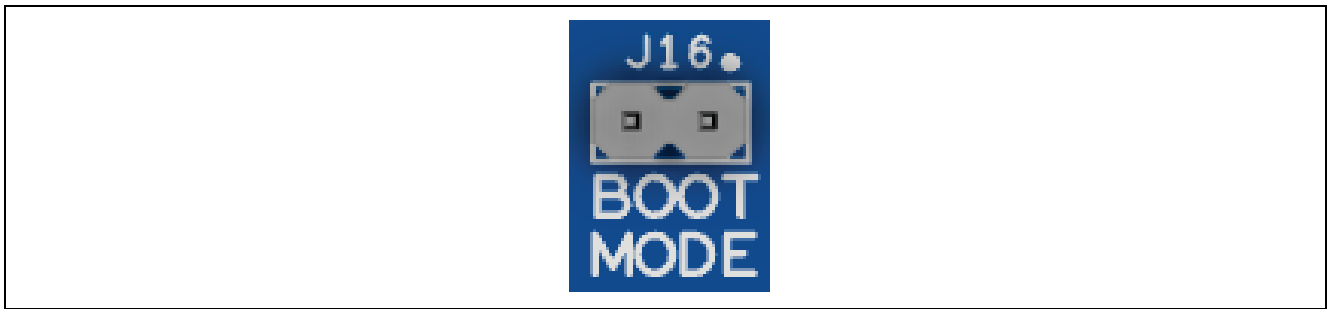

Figure 20. Boot Mode

## 6. Special Feature Access Area

The Special Feature Access area provides features specific to the RA8D1 MCU group such as Ethernet MAC controller and USB High Speed (Host and Device). The switches to control the peripheral interface selection is also provided.

Note: Normally the SDRAM and Octo-SPI devices would be in this area, however, to optimize the layout for this high-speed device, these components have been placed in the MCU Native Pin Access area.

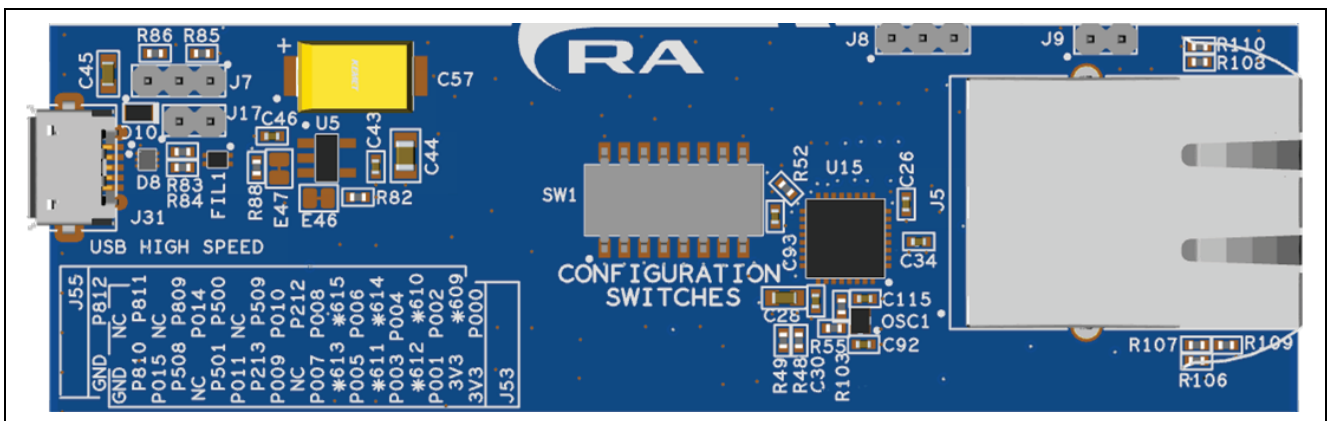

Figure 21. Special Feature Access Area

### 6.1 Ethernet

The Ethernet interface uses an RMII Ethernet Physical Layer Transceiver (PHY) (U15), connected to an RJ45 standard Ethernet connector (J5) with integrated magnetics and status indicators. The Ethernet clock is sourced from a precision 50 MHz clock oscillator connected directly to the Ethernet PHY.

The RMII signals used for the Ethernet port are connected from the RA MCU through two sets of bus switches. This is to allow different feature sets of the RA8D1 device to be evaluated, that would otherwise become unavailable. The switches SW1-4 and SW1-5 control the peripheral interface option used to communicate with the Ethernet PHY device. To isolate the Ethernet PHY from the RA MCU, turn off SW1-4 and SW1-5. Please see the section 4.3.4 for details.

**Table 24. Ethernet Port Assignments**

Ethernet Signal Description	EK-RA8D1	
	Signal/Bus	
	SW1-4 ON SW1-5 OFF	SW1-5 ON SW1-4 OFF
INT	P000	P000
MDC	P308	P401
MDIO	P307	P402
TXD1	P305	P406
TXD0	P304	P700
TXD_EN	P306	P405
RXD1	P301	P703
RXD0	P302	P702
RMII/RXDV	P112	P705
RX_ER	P300	P704
REFCLK	P303	P701
RESET_N	PA13	P706
LINKSTA	P114	P403

**CAUTION: Do not enable SW1-4 and SW1-5 together**

Both SW1-4 and SW1-5 can be disabled to allow these ports to be used as GPIO pins or other peripheral functions.

**Table 25. Ethernet Components**

Component	Manufacturer	Manufacturer Part Number
Ethernet PHY	Renesas	ICS1894-32
RJ45 Connector	Pulse	J0011D21BNL
50 MHz Oscillator	ECS Inc International	ECS-1612MV

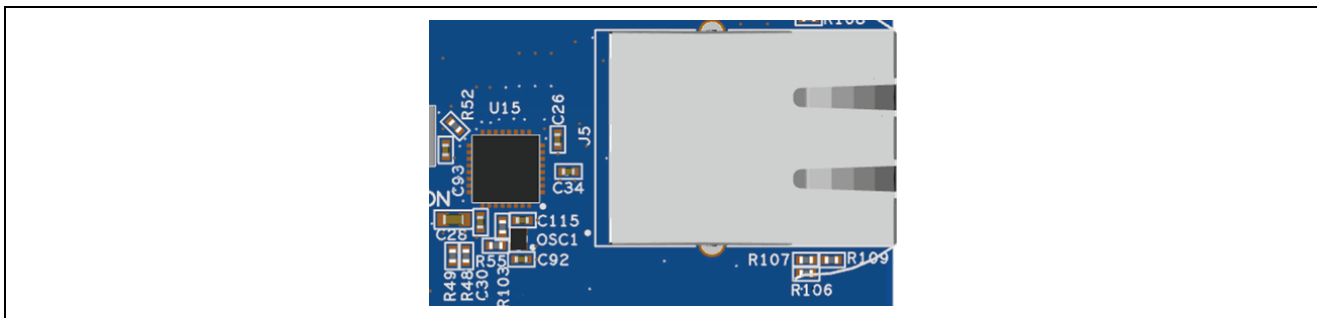

**Figure 22. Ethernet Connector**

## 6.2 USB High Speed

The USB Micro-AB connection jack (J31) connects the RA MCU USB High Speed interface to an external USB interface, allowing communications for testing and use of the RA MCU firmware. This connection can be configured as either a USB Device or a USB Host interface.

For a USB Device configuration, set jumper J7 to pins 2-3, install a jumper on J17 pins 1-2, and configure the RA MCU firmware to use the USB High Speed ports in device mode. Power from an external USB Host on this connection can be used to provide power to the EK-RA8D1 board.

For a USB Host configuration, set jumper J7 to pins 1-2, remove the jumper from J17, and configure the RA MCU firmware to use the USB High Speed ports in host mode. In this configuration, power to J7 is supplied from U5. The total current available from U5 is 500 mA. Note that the input power sources must be configured with enough power for both the EK-RA8D1 board and the USB Full Speed port in host mode. Connect the included USB type-A female to micro-B male cable to J31. USB device cables or devices can be connected to the USB High Speed port using this cable.

The USB High Speed support on this board is optional and cannot be used with the GLCD (Parallel LCD data bus) module. SW1-6 when turned on for GLCD will disable the USB Host, VBUS and Overcurrent controls.

**Table 26. USB High Speed Port Assignments**

USB High Speed Connector		EK-RA8D1
Pin	Description	Signal/Bus
J31-1	+5 VDC	+5V_USBHS (Host Mode) PB01/USBHS_VBUS = 2/3 of +5V_USBHS at J31*
J31-2	DM	USBHS_N
J31-3	DP	USBHS_P
J31-4	USB ID, jack internal switch, cable inserted	N.C.
J31-5	Ground	GND

\* Option SW1-6

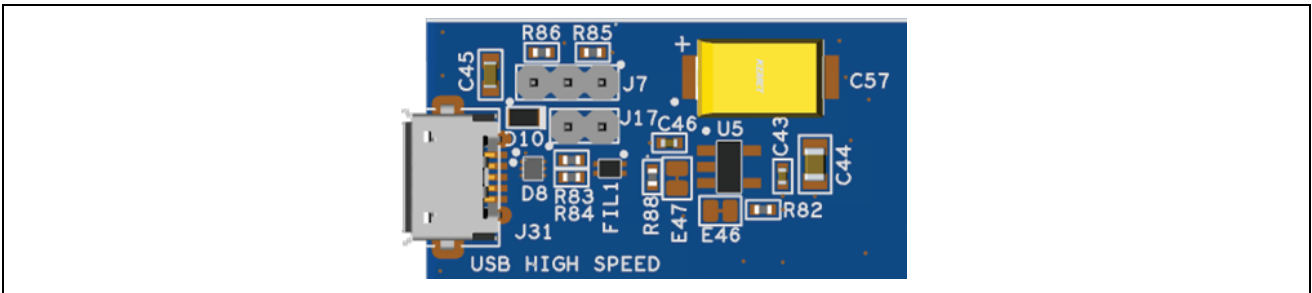

**Figure 23. USB High Speed Connector**

### 6.3 Octo-SPI Flash

Included on the EK-RA8D1 board is a 512 Mb (64 MB) Octo serial flash memory (S28HL512TFPBHI010). The Octo-SPI serial flash device (U3) connects to the Octo-SPI peripheral on the RA MCU and defaults to standard SPI mode initially. The flash memory is enabled for XIP (Execute-In-Place) mode directly after power-on.

The Octo-SPI signals are not provided on an external pin header due to the high speed of this interface.

**Table 27. Octo-SPI Flash Assignments**

Octo-SPI Flash Signal Description	EK-RA8D1
OSPI_RESET#	P106
OSPI_INT#	P105
OSPI_CK	P808
OSPI_CS#	P104
OSPI_DS	P801
OSPI_DQ0	P100
OSPI_DQ1	P803
OSPI_DQ2	P103
OSPI_DQ3	P101
OSPI_DQ4	P102
OSPI_DQ5	P800
OSPI_DQ6	P802
OSPI_DQ7	P804

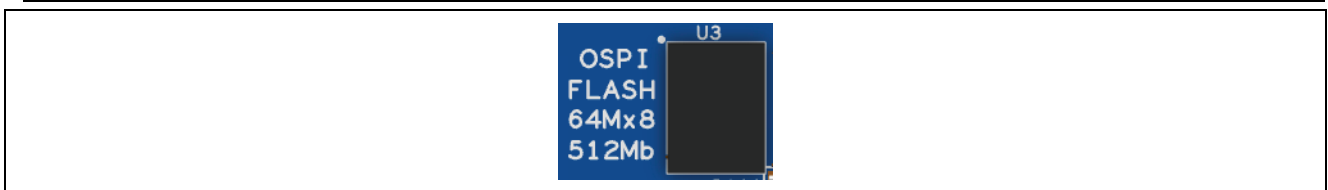

**Figure 24. Octo-SPI Flash**

## 6.4 SDRAM

Included in the EK-RA8D1 board is a 512 Mb (64 MB organized as 32M x 16 bits) SDRAM (IS42S16320F-6BLI). The SDRAM can be isolated from the MCU bus by turning SW1-7 off to allow the ports to be used for other purposes.

**Table 28. SDRAM Assignments**

<b>SDRAM</b>	<b>EK-RA8D1</b>
<b>Description</b>	<b>Signal/Bus</b>
SDRAM_A0	P300
SDRAM_A1	P301
SDRAM_A2	P302
SDRAM_A3	P303
SDRAM_A4	P304
SDRAM_A5	P305
SDRAM_A6	P306
SDRAM_A7	P307
SDRAM_A8	P308
SDRAM_A9	P309
SDRAM_A10	P310
SDRAM_A11	P311
SDRAM_A12	P312
SDRAM_BA0	P905
SDRAM_BA1	P906
SDRAM_D0	P601
SDRAM_D1	P602
SDRAM_D2	P603
SDRAM_D3	P604
SDRAM_D4	P605
SDRAM_D5	P606
SDRAM_D6	P607
SDRAM_D7	PA00
SDRAM_D8	P609
SDRAM_D9	P610
SDRAM_D10	P611
SDRAM_D11	P612
SDRAM_D12	P613
SDRAM_D13	P614
SDRAM_D14	P615
SDRAM_D15	PA08
SDRAM_CKE	P113
SDRAM_SDCLK	PA09
SDRAM_DQM1	P112
SDRAM_DQM0	PA10
SDRAM_WE	P114
SDRAM_CAS	P909
SDRAM_RAS	P908
SDRAM_CS	P115

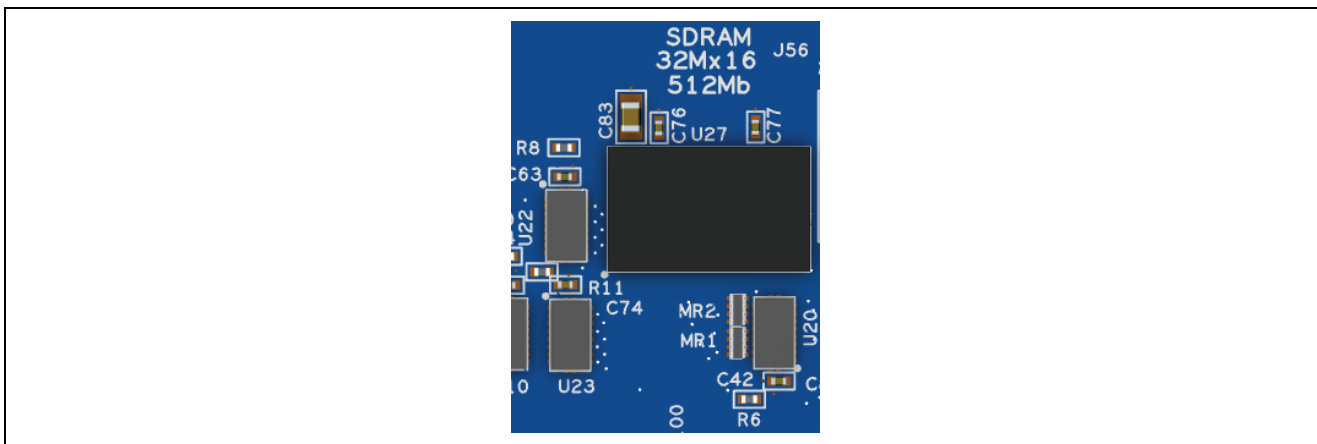

Figure 25. SDRAM

### 6.5 Parallel Graphics Expansion Port

The RA MCU parallel graphics expansion port can be configured with 8-8-8, 6-6-6, and 5-6-5 color depth. Table 29 shows the Parallel Graphics Expansion Port Assignments and signal names for the EK-RA8D1 board.

Note that P510, which is used as the interrupt for the capacitive touch portion of the LCD, must have the internal pull-up feature enabled in the RA8D1 MCU configuration. This will ensure proper responsiveness of the LCD capacitive touch overlay.

Some signals used on the parallel graphics expansion port are also used by USB-HS. To ensure correct operation, please check Table 3 and Table 4.

Table 29. Parallel Graphics Expansion Port Assignments

Parallel Graphics Expansion Port		EK-RA8D1			
Pin	Description	Signal/Bus	RGB Signal (RGB888)	RGB Signal (RGB666)	RGB Signal (RGB565)
J57-1	DISP_BLEN	P404	BLEN	BLEN	BLEN
J57-2	IIC_SDA	P511	SDA	SDA	SDA
J57-3	DISP_INT	P510	INT	INT	INT
J57-4	IIC_SCL	P512	SCL	SCL	SCL
J57-5	+3.3 V	+3.3 V	+3.3 V	+3.3 V	+3.3 V
J57-6	DISP_RST	PA01	RST	RST	RST
J57-7	+3.3 V	+3.3 V	+3.3 V	+3.3 V	+3.3 V
J57-8	+5 V	+5 V	+5 V	+5 V	+5 V
J57-9	LCDC_TCON0	P805	TCON0	TCON0	TCON0
J57-10	LCDC_CLK	P806	CLK	CLK	CLK
J57-11	LCDC_TCON2	P513	TCON2	TCON2	TCON2
J57-12	LCDC_TCON1	P807	TCON1	TCON1	TCON1
J57-13	LCDC_EXTCLK	P514	EXTCLK	EXTCLK	EXTCLK
J57-14	LCDC_TCON3	P515	TCON4	TCON4	TCON4
J57-15	LCDC_DATA01	P915	B1	B3	B4
J57-16	LCDC_DATA00	P914	B0	B2	B3
J57-17	LCDC_DATA03	P911	B3	B5	B6
J57-18	LCDC_DATA02	P910	B2	B4	B5
J57-19	LCDC_DATA05	P913	B5	B7	G2
J57-20	LCDC_DATA04	P912	B4	B6	B7
J57-21	LCDC_DATA07	P903	B7	G3	G4
J57-22	LCDC_DATA06	P904	B6	G2	G3
J57-23	LCDC_DATA09	P207	G1	G5	G6
J57-24	LCDC_DATA08	P902	G0	G4	G5
J57-25	LCDC_DATA11	P712	G3	G7	R3
J57-26	LCDC_DATA10	P711	G2	G6	G7

Parallel Graphics Expansion Port		EK-RA8D1			
Pin	Description	Signal/Bus	RGB Signal (RGB888)	RGB Signal (RGB666)	RGB Signal (RGB565)
J57-27	LCDC_DATA13	P714	G5	R3	R5
J57-28	LCDC_DATA12	P713	G4	R2	R4
J57-29	LCDC_DATA15	PB07	G7	R5	R7
J57-30	LCDC_DATA14	P715	G6	R4	R6
J57-31	LCDC_DATA17	PB05	R1	R7	N.C.
J57-32	LCDC_DATA16	PB06	R0	R6	N.C.
J57-33	LCDC_DATA19	PB04	R3	N.C.	N.C.
J57-34	LCDC_DATA18	PB01	R2	N.C.	N.C.
J57-35	LCDC_DATA21	PB02	R5	N.C.	N.C.
J57-36	LCDC_DATA20	PB03	R4	N.C.	N.C.
J57-37	LCDC_DATA23	P707	R7	N.C.	N.C.
J57-38	LCDC_DATA22	PB00	R6	N.C.	N.C.
J57-39	GND	GND	GND	GND	GND
J57-40	GND	GND	GND	GND	GND

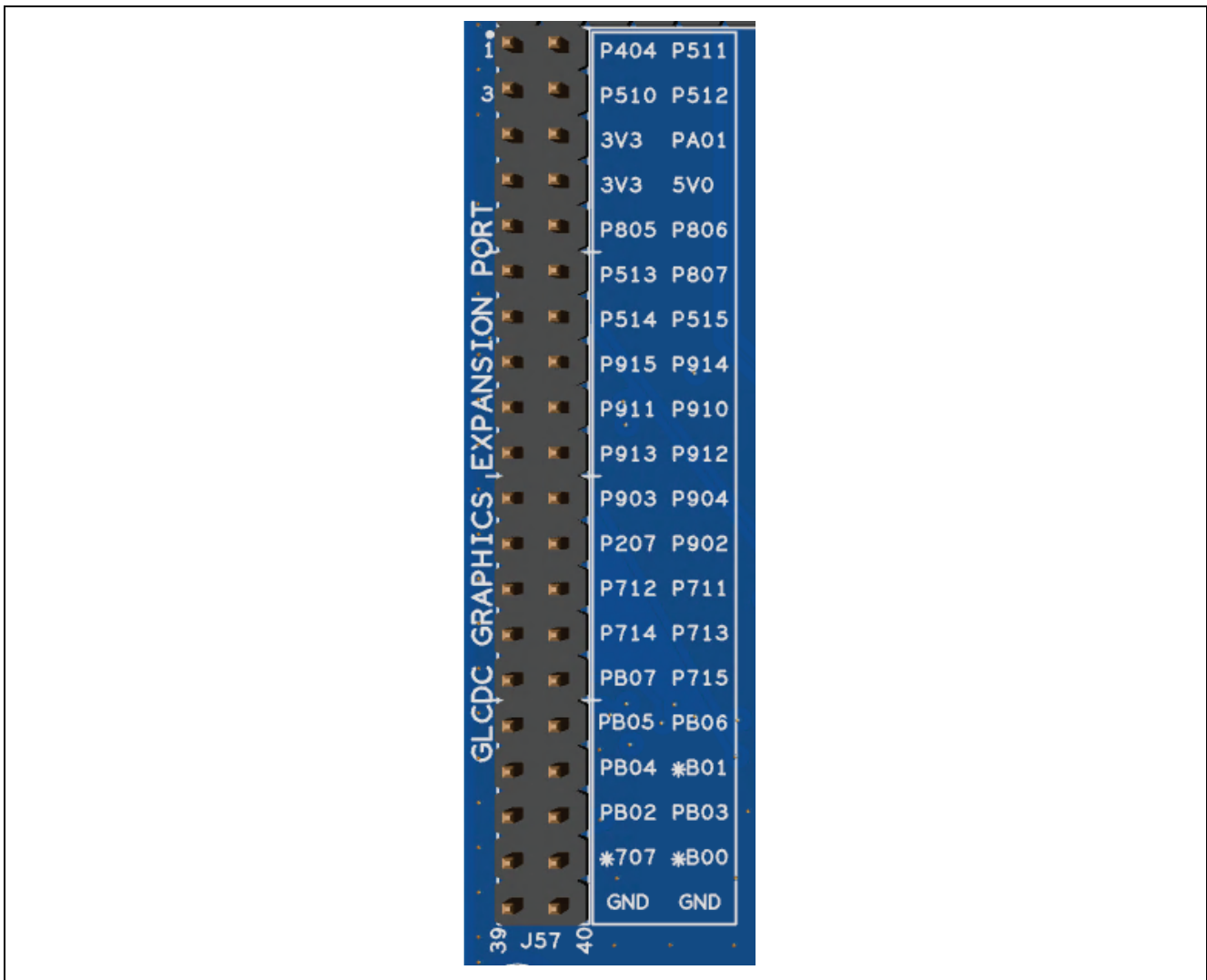

Figure 26. Parallel Graphics Expansion Port

## 7. MCU Native Pin Access Area

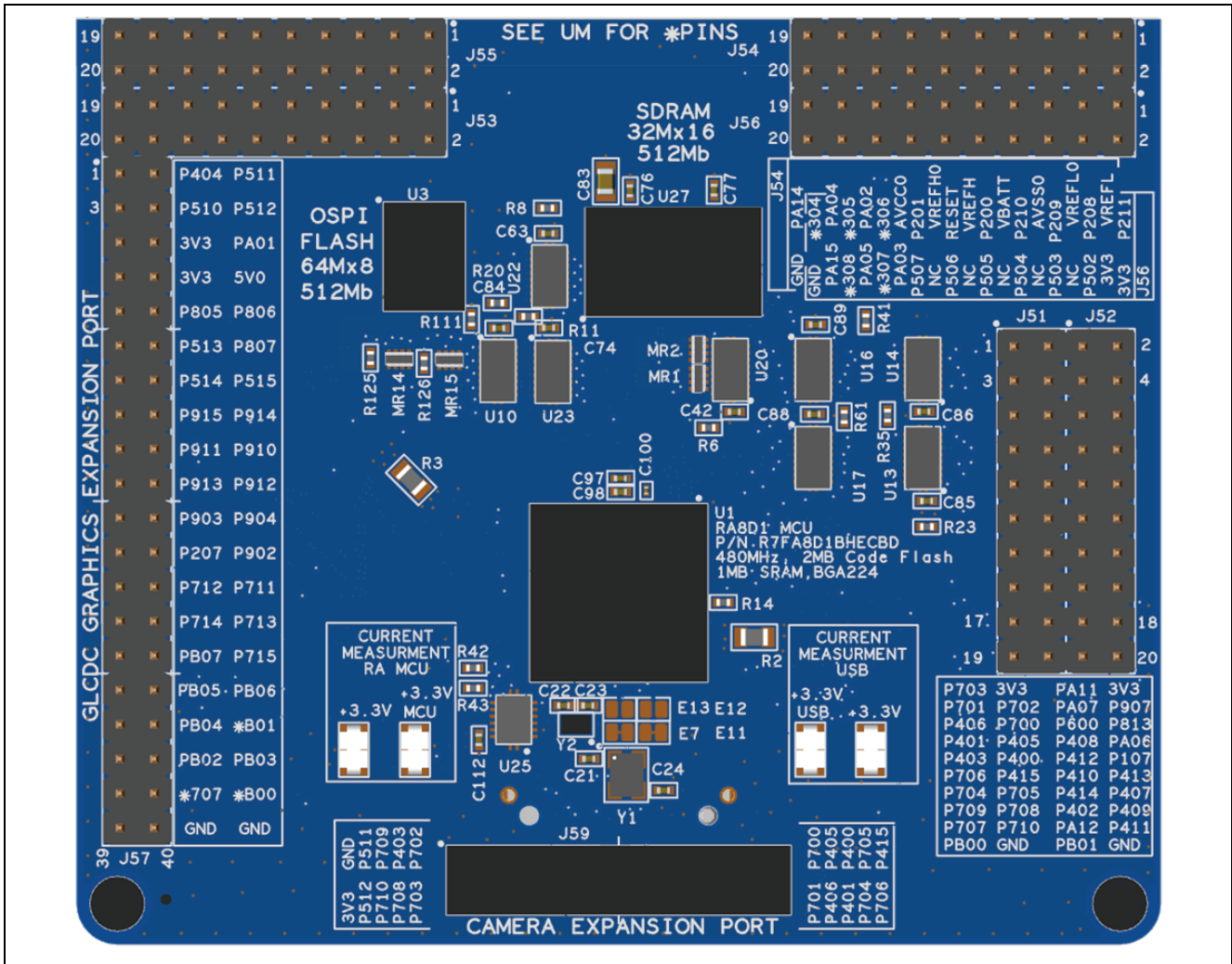

Figure 27. Native Pin Access Area

### 7.1 Breakout Pin Headers

The EK-RA8D1 board pin headers, J51, J52, J53, J54, J55 and J56 provide access to nearly all RA MCU interface signals, and to voltages for all RA MCU power ports. Each header pin is labelled with the voltage or port connected to that pin. Refer to the RA8D1 MCU Group User's Manual for details of each port function, and the EK-RA8D1 board schematic for pin header port assignments.

The placement of the breakout pin headers allows for a standard 2.54 mm (0.100") center breadboard to be placed on all pin headers simultaneously. This can be used for prototyping and testing of custom circuitry for use with the RA8D1 MCU.

### 7.2 MCU and USB Current Measurement

Included in the Native Pin Access area are current measurement resistors and test points to measure the MCU USB controller current and the MCU core power current.

The EK-RA8D1 board provides precision 5 mΩ resistors (Vishay, part number WSLP08055L000FEA18) for current measurement of the main 3.3 V MCU power and the 3.3 V USB MCU power. Measure the voltage drop across these resistors and use Ohm's Law to calculate the current. For convenience, TP1 and TP3 are provided to measure the main 3.3 V MCU power, and TP2 and TP4 are provided to measure the 3.3 V USB MCU power. See Figure 30 for the location of TP1, TP2, TP3 and TP4.

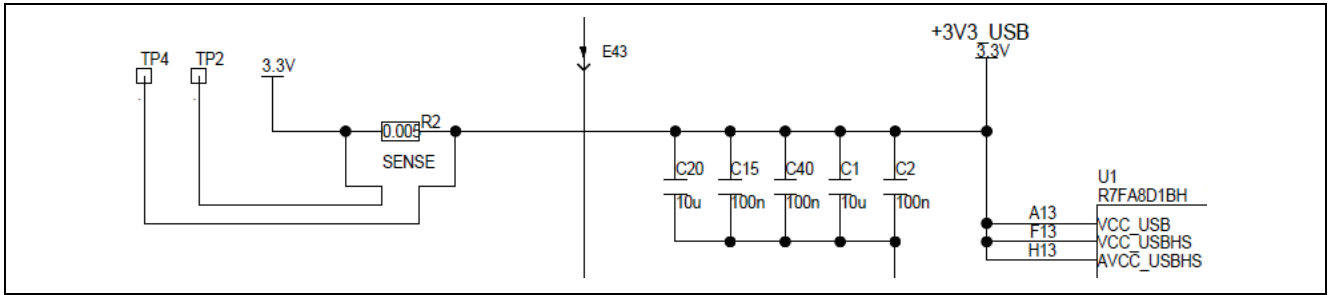

Figure 28. RA USB Current Measurement Circuit

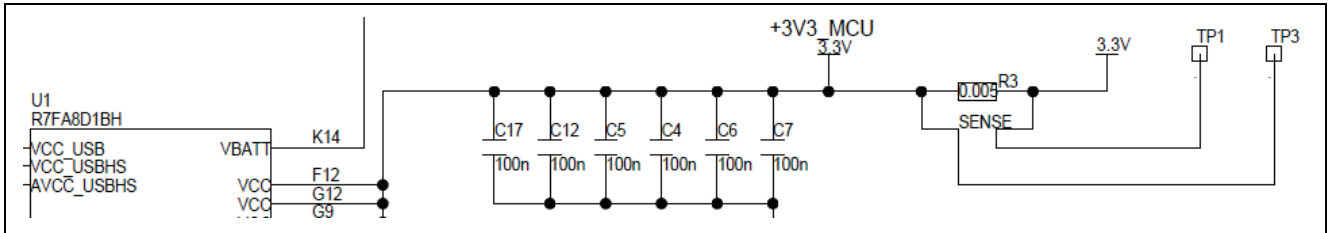

Figure 29. RA +3.3 V Current Measurement Circuit

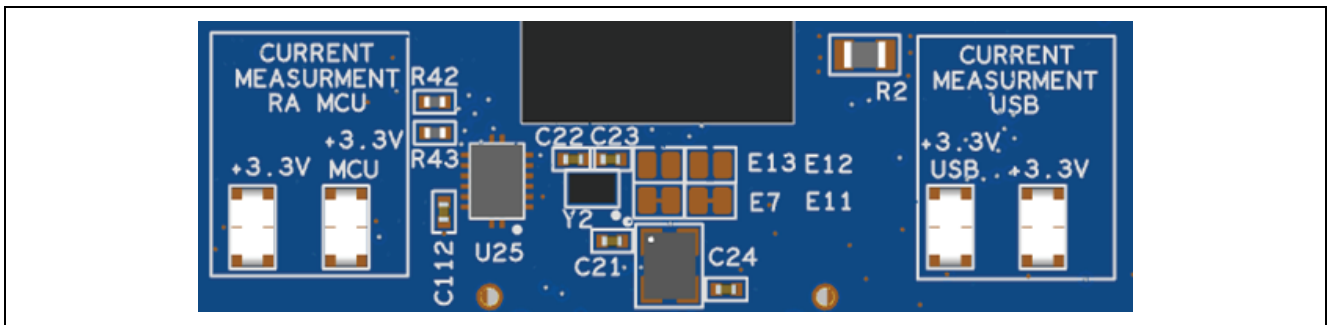

Figure 30. RA MCU and USB Current Measurement



## 8. Expansion Boards

The EK-RA8D1 kit includes the MIPI Graphics and Camera expansion boards.

### 8.1 MIPI Graphics Expansion Board

#### 8.1.1 Connecting the Graphics Expansion Board to the EK-RA8D1 Board

The MIPI Graphics Expansion Board connects to the EK-RA8D1 board via 2-lane MIPI interface. It features a 4.5 inch TFT LCD with capacitive touch overlay and must be securely mounted to the EK-RA8D1 board using the provided nylon pillars prior to operation.

Some of the key features of the TFT LCD used on the MIPI Graphics Expansion Board are as follows:

- Display type: TFT LCD with capacitive touch overlay and backlight
- Diagonal size: 4.5 inch
- Dimensions: 61.54x110.09 mm
- Resolution: 854x480 pixels
- Display colors: 16.7M
- Viewing angle: 12:00
- Display mode: transmissive/normally white
- Display brightness: 276

The part number of the TFT LCD used on the MIPI Graphics Expansion Board is E45RA-MW276-C. For more details, please visit [focusLCDs.com](http://focusLCDs.com)

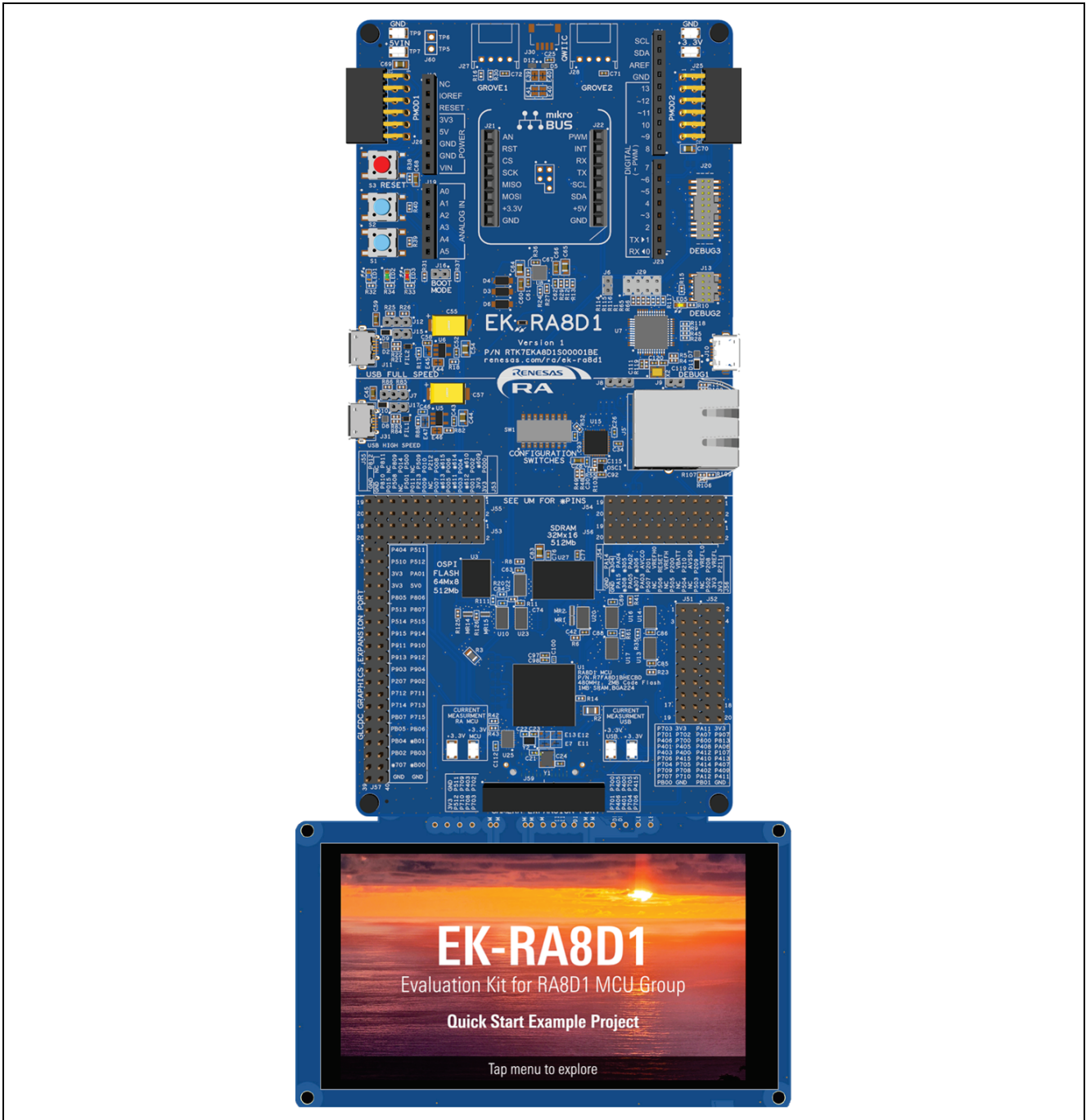

Figure 31. EK-RA8D1 Board Connected with MIPI Graphics Expansion Board

### 8.1.2 Signal Assignments

The MIPI Graphics Expansion Port (J58) connects the EK-RA8D1 board to the MIPI Graphics Expansion Board supplied as part of the kit.

**Table 30. MIPI Graphics Expansion Port Assignments**

MIPI Expansion Port Assignments		EK-RA8D1
Pin	Description	Signal/Bus
J58-1	GND	GND
J58-2	GND	GND
J58-3	MIPI_DL0_P	MIPI_DL0_P
J58-4	MIPI_DL1_P	MIPI_DL1_P
J58-5	MIPI_DL0_N	MIPI_DL0_N
J58-6	MIPI_DL1_N	MIPI_DL1_N
J58-7	GND	GND
J58-8	GND	GND
J58-9	MIPI_CL_P	MIPI_CL_P
J58-10	MIPI	P206
J58-11	MIPI_CL_N	MIPI_CL_N
J58-12	GND	GND
J58-13	GND	GND
J58-14	I <sup>2</sup> C SDA	P511
J58-15	DISP_BLEN	P404
J58-16	I <sup>2</sup> C SCL	P512
J58-17	DISP_INT	P510
J58-18	DISP_RST	PA01
J58-19	GND	GND
J58-20	GND	GND
J58-21	+1.8 V	+1.8 V
J58-22	+1.8 V	+1.8 V
J58-23	+3.3 V	+3.3 V
J58-24	+3.3 V	+3.3 V
J58-25	+5 V	+5 V
J58-26	+5 V	+5 V

## 8.2 Camera Expansion Board

### 8.2.1 Connecting the Camera Expansion Board to the EK-RA8D1 Board

The Camera Expansion Board included in the EK-RA8D1 kit is off-the-shelf “Arducam 1/4” 3 Mega pixel M12 Mount OV3640 Camera Module with JPEG Output.” It connects to the EK-RA8D1 board using the Camera Expansion Port. Some of the key features of the Camera Expansion Board are as follows:

- External ¼ inch high quality M12x0.5 lens, size:1/4”
- Active array size: 2048 x 1536
- Interface: Parallel RAW, RGB, YUV, JPEG output
- Output formats: (8-bit): YUV (422/420) / YCbCr422, RGB565/555/444, CCIR656, 8-bit compression data, 8/10-bit raw RGB data
- Maximum image transfer rate:
  - 3 megapixel (2048 x 1536): 15 fps (and any size scaling down from 3 megapixel)
  - XGA (1024 x 768): 30 fps
- Scan mode: progressive
- Input clock frequency: 6 ~ 54 MHz
- Shutter: rolling shutter

The part number of the Camera Expansion Board is ArduCam B0156. For more details, please visit [arducam.com](http://arducam.com)

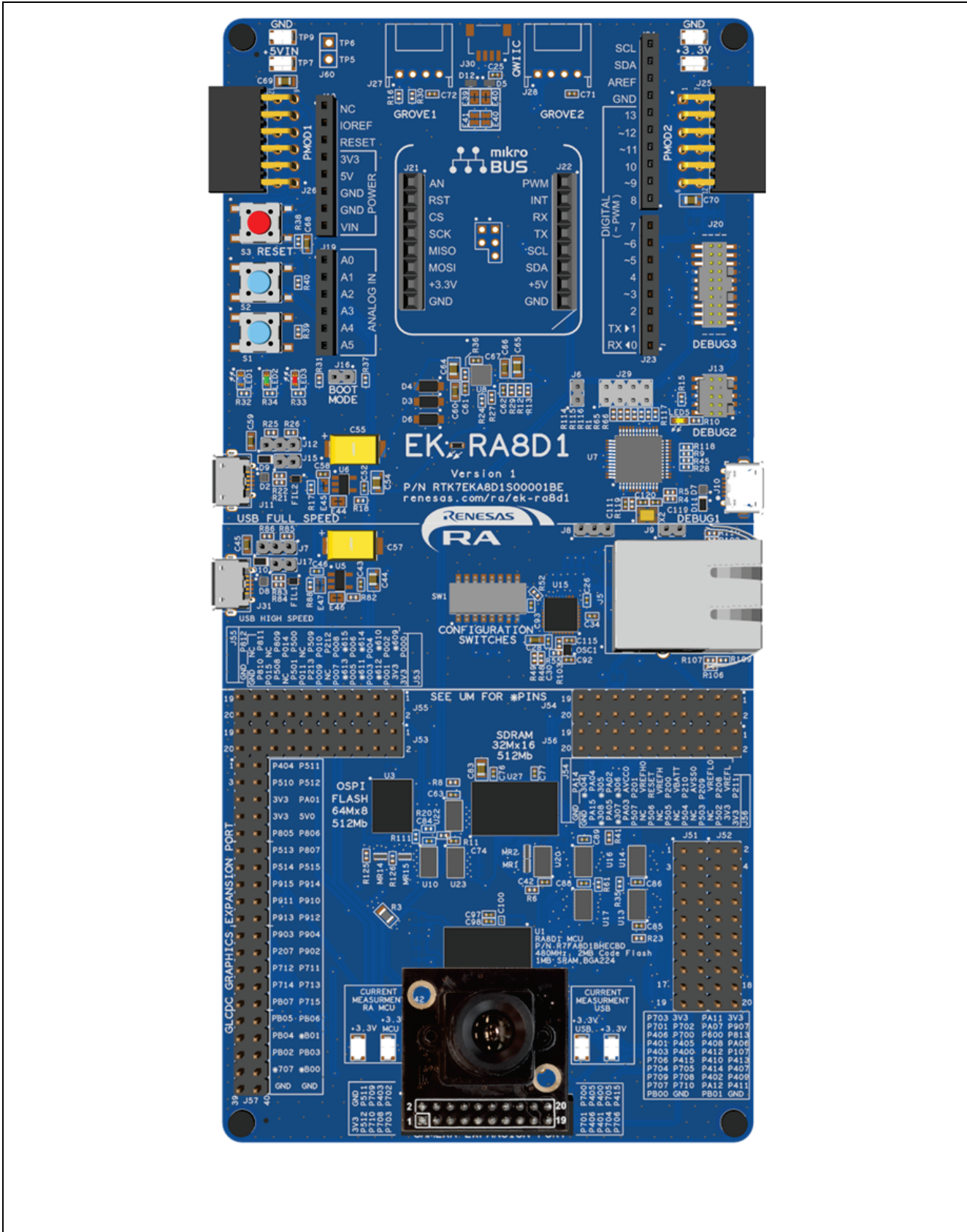

Figure 32. EK-RA8D1 Board Connected with Camera Expansion Board

## 8.2.2 Signal Assignments

The camera connector J59 connects the EK-RA8D1 board to the camera module supplied as part of the kit.

**Table 31. Camera Expansion Port Assignments**

Camera Expansion Port Assignments		EK-RA8D1
Pin	Description	Signal/Bus
J59-1	GND	GND
J59-2	+3.3 V	+3.3 V
J59-3	I <sup>2</sup> C SDA	P511 (SDA1)
J59-4	I <sup>2</sup> C SCL	P512 (SCL1)
J59-5	CAM_HD	P709
J59-6	CAM_VD	P710
J59-7	CAM_XCLK	P403
J59-8	CAM_CLK	P708
J59-9	CAM_D6	P702
J59-10	CAM_D7	P703
J59-11	CAM_D4	P700
J59-12	CAM_D5	P701
J59-13	CAM_D2	P405
J59-14	CAM_D3	P406
J59-15	CAM_D0	P400
J59-16	CAM_D1	P401
J59-17	CAM_D9	P705
J59-18	CAM_D8	P704
J59-19	CAM_D12	P415
J59-20	CAM_D10	P706

## 9. Certifications

The EK-RA8D1 v1 kit meets the following certifications/standards. See page 3 of this user's manual for the disclaimer and precautions.

### 9.1 EMC/EMI Standards

- FCC Notice (Class A)



This device complies with part 15 of the FCC Rules. Operation is subject to the following two conditions: (1) This device may not cause harmful interference, and (2) this device must accept any interference received, including interference that may cause undesired operation.

NOTE- This equipment has been tested and found to comply with the limits for a Class A digital device, pursuant to Part 15 of the FCC Rules. These limits are designed to provide reasonable protection against harmful interference in a residential installation. This equipment generates, uses and can radiate radio frequency energy and, if not installed and used in accordance with the instructions, may cause harmful interference to radio communications. However, there is no guarantee that interference will not occur in a particular installation. If this equipment does cause harmful interference to radio or television reception, which can be determined by turning the equipment off and on, the user is encouraged to try to correct the interference by one or more of the following measures:

- Reorient or relocate the receiving antenna.
- Increase the separation between the equipment and receiver.
- Connect the equipment into an outlet on a circuit different from that to which the receiver is connected.
- Consult the dealer or an experienced radio/television technician for help.

- Innovation, Science and Economic Development Canada ICES-003 Compliance:

CAN ICES-3 (A)/NMB-3(A)

- CE Class A (EMC)



This product is herewith confirmed to comply with the requirements set out in the Council Directives on the Approximation of the laws of the Member States relating to Electromagnetic Compatibility Directive 2014/30/EU.

**Warning** – This is a Class A product. In a domestic environment this product may cause radio interference in which case the user may be required to take adequate measures to correct this interference.

- UKCA Class A (EMC)



This product is in conformity with the following relevant UK Statutory Instrument(s) (and its amendments): 2016 No. 1091 Electromagnetic Compatibility Regulations 2016.

**Warning** – This is a Class A product. In a domestic environment this product may cause radio interference in which case the user may be required to take adequate measures to correct this interference.

- Taiwan: Chinese National Standard 13438, C6357 compliance, Class A limits
- Australia/New Zealand AS/NZS CISPR 32:2015, Class A

### 9.2 Material Selection, Waste, Recycling and Disposal Standards

- EU RoHS
- WEEE
- China SJ/T 113642014, 10-year environmental protection use period.

### 9.3 Safety Standards

- UL 94V-0

## 10. Design and Manufacturing Information

The design and manufacturing information for the EK-RA8D1 v1 kit is available in the “EK-RA8D1 v1 Design Package” available on [renesas.com/ra/ek-ra8d1](https://renesas.com/ra/ek-ra8d1).

- Design package file name: ek-ra8d1kit-v1-designpackage.zip
- Design package contents:
  1. EK-RA8D1 Board design package: ek-ra8d1-v1-designpackage.zip
  2. MIPI Graphics Expansion Board design package: mgeb-v1-designpackage.zip

**Table 32. EK-RA8D1 Board Design Package Contents**

File Type	Content	File/Folder Name
File (PDF)	Schematics	ek-ra8d1-v1-schematics
File (PDF)	Mechanical Drawing	ek-ra8d1-v1-mechdwg
File (PDF)	3D Drawing	ek-ra8d1-v1-3d
File (PDF)	BOM	ek-ra8d1-v1-bom
Folder	Manufacturing Files	Manufacturing Files
Folder	Design Files	Design Files-Cadence Allegro

**Table 33. MIPI Graphics Expansion Board Design Package Contents**

File Type	Content	File/Folder Name
File (PDF)	Schematics	mgeb-v1-schematics
File (PDF)	Mechanical Drawing	mgeb-v1-mechdwg
File (PDF)	3D Drawing	mgeb-v1-3d
File (PDF)	BOM	mgeb-v1-bom
Folder	Manufacturing Files	Manufacturing Files
Folder	Design Files	Design Files-Cadence Allegro

## 11. Website and Support

Visit the following URLs to learn about the kit and the RA family of microcontrollers, download tools and documentation, and get support.

EK-RA8D1 Resources	<a href="https://renesas.com/ra/ek-ra8d1">renesas.com/ra/ek-ra8d1</a>
RA Kit Information	<a href="https://renesas.com/ra/kits">renesas.com/ra/kits</a>
RA Product Information	<a href="https://renesas.com/ra">renesas.com/ra</a>
RA Product Support Forum	<a href="https://renesas.com/ra/forum">renesas.com/ra/forum</a>
RA Videos	<a href="https://renesas.com/ra/videos">renesas.com/ra/videos</a>
RA Kit Feedback and Feature Request	<a href="https://renesas.com/ra/kitfeedback">renesas.com/ra/kitfeedback</a>
Renesas Support	<a href="https://renesas.com/support">renesas.com/support</a>

### Provide Feedback/Request a Feature

Renesas aims to provide the best microcontroller kit experience to help our customers jumpstart innovation and take products to market faster with the RA family of microcontrollers. The Renesas RA microcontroller kits have been designed with a lot of attention to detail and customer-centered thinking in every aspect of the design. Renesas aims to exceed customer expectation.

Renesas looks forward to hearing your feedback and learning how we can enhance your experience. Please share your feedback at [renesas.com/ra/kitfeedback](https://renesas.com/ra/kitfeedback).

**Revision History**

Rev.	Date	Description	
		Page	Summary
1.00	Nov.16.23	—	Initial release
1.01	Jan.12.24	5, 6, 10, 12, 17, 22, 23, 26, 39, 41	Added note regarding Qwiic connections. Updated wording and images to account for J27, J28 and J30 no longer being fitted.



---

EK-RA8D1 v1 – User's Manual

Publication Date: Jan.22.24

Published by: Renesas Electronics Corporation

---

# EK-RA8D1 v1 – User's Manual