

## Description

The HI5805EVAL1 evaluation board is made available to allow the circuit designer the ability to evaluate the performance of the Intersil HI5805 monolithic 12-bit 5MSPS analog-to-digital converter (ADC). As shown in the Evaluation Board Functional Block Diagram, this evaluation board includes sample clock generation circuitry, a single-ended to differential analog input amplifier configuration and digital data output latches/buffers. The buffered digital data outputs are conveniently provided for easy interfacing to a ribbon connector or logic probes. In addition, the evaluation board is provided with some prototyping area for the addition of user designed custom interfaces or circuits.

The sample clock generator circuit accepts the external sampling signal through an SMA type RF connector, J2. This input is AC-coupled and terminated in 50Ω allowing for

connection to most laboratory signal generators. In addition, the duty cycle of the clock driving the A/D converter is made adjustable by way of a potentiometer so that the effects of sample clock duty cycle on the HI5805 may be observed.

The analog input signal is also connected through an SMA type RF connector, J1, and applied to a single-ended to differential analog input amplifier. This input is AC-coupled and terminated in 50Ω allowing for connection to most laboratory signal generators. A differential RC lowpass filter is incorporated on the output of the differential amplifier to limit the broadband noise going into the HI5805 converter.

The digital data output latches/buffers consist of a pair of 74ALS574A D-type flip-flops. With this digital output configuration the digital output data transitions seen at the I/O connector are essentially time aligned with the rising edge of the sampling clock.

## Evaluation Board Functional Block Diagram

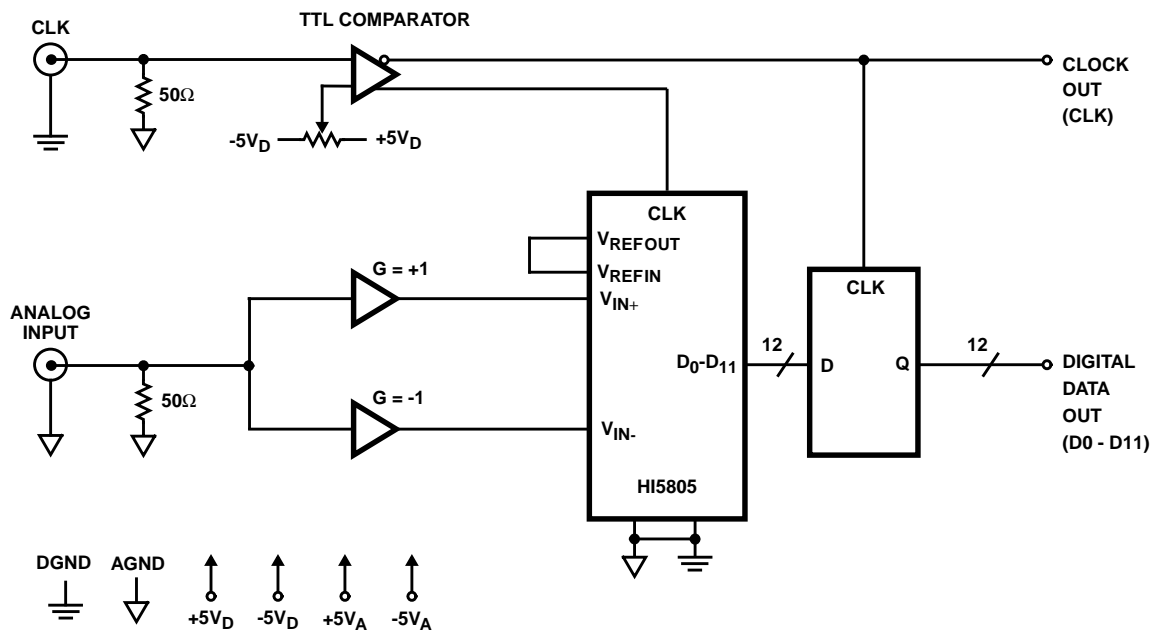

### HI5805 A/D Theory of Operation

The HI5805 is a 12-bit fully differential sampling pipelined A/D converter with digital error correction. Figure 1 depicts the circuit for the converters front-end differential-in-differential-out sample-and-hold (S/H). The sampling switches are controlled by internal sampling clock signals which consist of two phase non-overlapping clock signals,  $\phi_1$  and  $\phi_2$ , derived from the master clock (CLK) driving the converter. During the sampling phase,  $\phi_1$ , the input signal is applied to the sampling capacitors,  $C_S$ . At the same time the holding capacitors,  $C_H$ , are discharged to analog ground. At the falling edge of  $\phi_1$  the input analog signal is sampled on the bottom plates of the sampling capacitors. In the next clock phase,  $\phi_2$ , the two bottom plates of the sampling capacitors are connected together and the holding capacitors are switched to the op amp output nodes. The charge then redistributes between  $C_S$  and  $C_H$ , completing one sample-and-hold cycle. The output of the sample-and-hold is a fully-differential, sampled-data representation of the analog input. The circuit not only performs the sample-and-hold function, but can also convert a single-ended input to a fully-differential output for the converter core. During the sampling phase, the  $V_{IN}$  pins see only the on-resistance of the switches and  $C_S$ . The relatively small values of these components result in a typical full power input bandwidth of 100MHz for the converter.

As illustrated in the HI5805 Functional Block Diagram and the timing diagram contained Figure 2, three identical pipeline subconverter stages, each containing a four-bit flash converter, a four-bit digital-to-analog converter and an amplifier with a voltage gain of 8, follow the S/H circuit with the fourth stage being only a 4-bit flash converter. Each converter stage in the pipeline will be sampling in one phase and amplifying in the other clock phase. Each individual sub-converter clock signal is offset by 180 degrees from the previous stage clock signal, with

the result that alternate stages in the pipeline will perform the same operation. The output of each of the three identical four-bit subconverter stages is a four-bit digital word containing a supplementary bit to be used by the digital error correction logic. The output of each subconverter stage is input to a digital delay line which is controlled by the internal clock. The function of the digital delay line is to time align the digital outputs of the three identical four-bit subconverter stages with the corresponding output of the fourth stage flash converter before inputting the sixteen bit result into the digital error correction logic. The digital error correction logic uses the supplementary bits to correct any error that may exist before generating the final twelve-bit digital data output (D0-D11) of the converter.

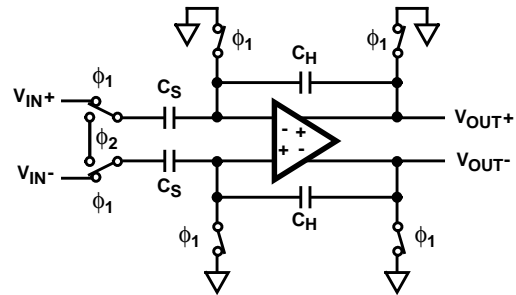
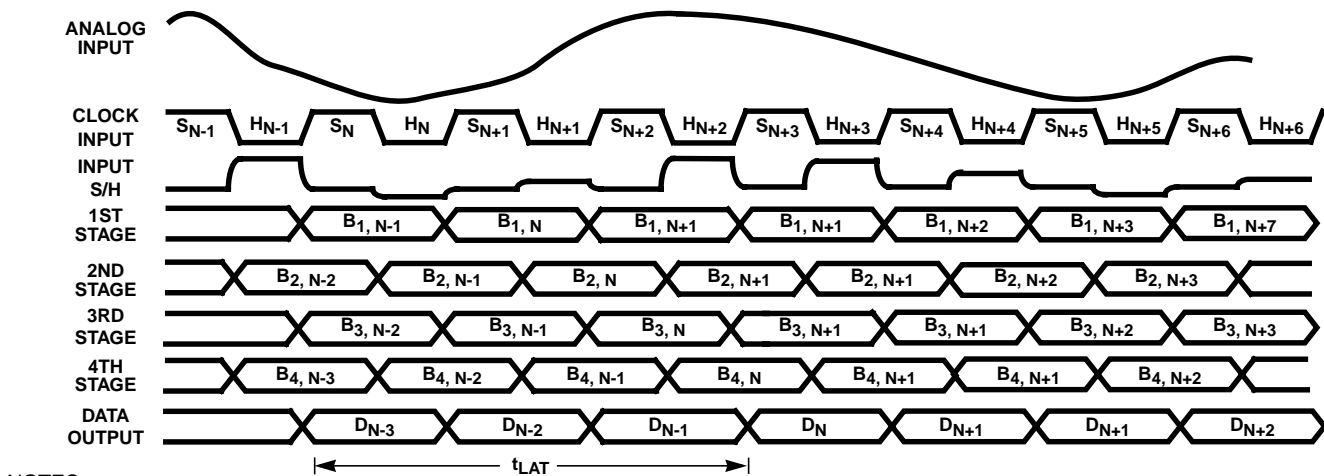

FIGURE 1. ANALOG INPUT SAMPLE-AND-HOLD

Because of the pipeline nature of this converter, the digital data representing an analog input sample is presented on the digital data output bus on the 3rd cycle of the clock after the analog sample is taken. This delay is specified as the data latency. After the data latency time, the data representing each succeeding analog sample is output on the following clock pulse. The output data is synchronized to the external sampling clock with a data latch and is presented in offset binary format.



NOTES:

1.  $S_N$ : N-th sampling period.
2.  $H_N$ : N-th holding period.
3.  $B_M, N$ : M-th stage digital output corresponding to N-th sampled input.
4.  $D_N$ : Final data output corresponding to N-th sampled input.

FIGURE 2. HI5805 INTERNAL CIRCUIT TIMING

HI5805 Functional Block Diagram

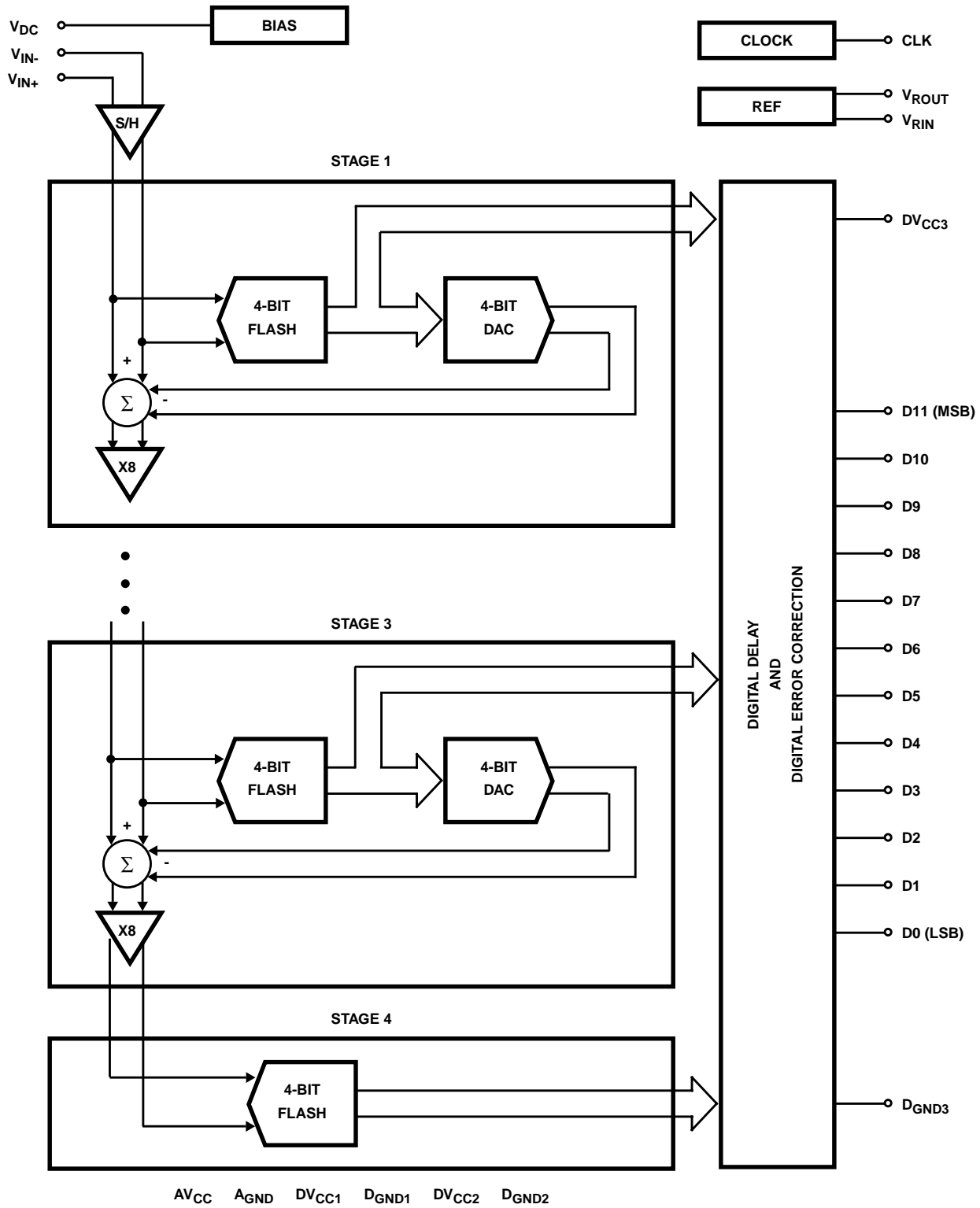

## Reference Generator, $V_{ROUT}$ and $V_{RIN}$

The HI5805 has an internal reference voltage generator, therefore no external reference voltage is required.  $V_{ROUT}$  must be connected to  $V_{RIN}$  when using the internal reference. Internal to the converter, two reference voltages of 1.3V and 3.3V are generated making for a fully differential analog input signal range of  $\pm 2V$ .

The HI5805 can be used with an external reference. The converter requires only one external reference voltage connected to the  $V_{RIN}$  pin with  $V_{ROUT}$  left open. The evaluation board is configured with  $V_{ROUT}$  connected to  $V_{RIN}$  through a  $0\Omega$  resistor,  $R_{15}$ . If it is desired to evaluate the performance of the converter utilizing an externally provided reference voltage,  $R_{15}$  can be removed and the alternate reference voltage can be brought in through twisted pair wire or coaxial cable. The latter would be the recommended method since it would provide the greatest immunity to externally coupled noise voltages. In order to minimize overall converter noise it is recommended that adequate high frequency decoupling be provided at the reference input pin,  $V_{RIN}$ .

## Analog Input

The fully differential analog input of the HI5805 A/D can be configured in various ways depending on the signal source and the required level of performance.

## Differential Analog Input Configuration

A fully differential connection (Figure 3) will yield the best performance from the HI5805 A/D converter. Since the HI5805 is powered off a single +5V supply, the analog input must be biased so it lies within the analog input common mode voltage range of 1.0V to 4.0V. Figure 4 illustrates the differential analog input common mode voltage range that the converter will accommodate. The performance of the ADC does not change significantly with the value of the common mode voltage.

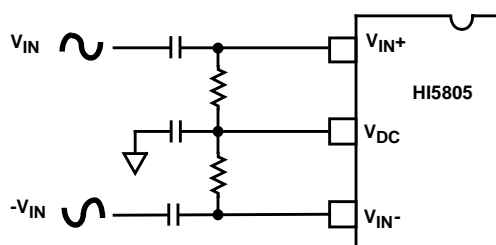

FIGURE 3. AC COUPLED DIFFERENTIAL INPUT

A 2.3V DC bias voltage source,  $V_{DC}$ , half way between the top and bottom internally generated reference voltages, is made available to the user to help simplify circuit design when using a differential input. This low output impedance voltage source is not designed to be a reference but makes an excellent bias source and stays within the analog input common mode voltage range over temperature. The DC voltage source has a temperature coefficient of about  $+200\text{ppm}/^\circ\text{C}$ .

The difference between the converter's two internally generated voltage references is 2V. For the AC coupled differential input, (Figure 3), if  $V_{IN}$  is a  $2V_{P-P}$  sinewave with  $-V_{IN}$  being 180 degrees out of phase with  $V_{IN}$ , the converter will be at positive full scale when the  $V_{IN+}$  input is at  $V_{DC} + 1V$  and the  $V_{IN-}$  input is at  $V_{DC} - 1V$  ( $V_{IN+} - V_{IN-} = +2V$ ). Conversely, the ADC will be at negative full scale when the  $V_{IN+}$  input is equal to  $V_{DC} - 1V$  and  $V_{IN-}$  is at  $V_{DC} + 1V$  ( $V_{IN+} - V_{IN-} = -2V$ ).

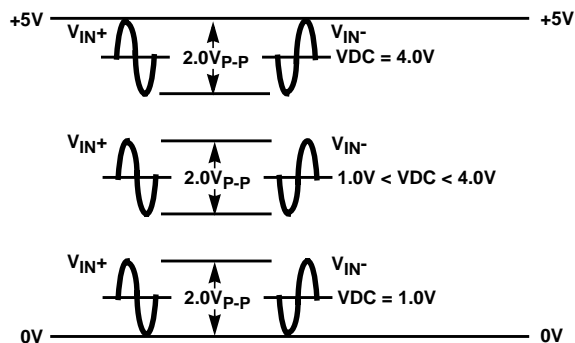

FIGURE 4. DIFFERENTIAL ANALOG INPUT COMMON MODE VOLTAGE RANGE

## Evaluation Board Layout and Power Supplies

The HI5805 evaluation board is a four layer board with a layout optimized for the best performance of the ADC. This application note includes an electrical schematic of the evaluation board, a component parts list, a component placement layout drawing and reproductions of the various board layers used in the board stack-up. The user should feel free to copy the layout in their application. Refer to the component layout and the evaluation board electrical schematic for the following discussions.

The HI5805 monolithic A/D converter has been designed with separate analog and digital supply and ground pins to keep digital noise out of the analog signal path. The evaluation board provides separate low impedance analog and digital ground planes on layer 2. Since the analog and digital ground planes are connected together at a single point where the power supplies enter the board, **DO NOT** tie them together back at the power supplies.

The analog and digital supplies are also kept separate on the evaluation board and should be driven by clean linear regulated supplies. The external power supplies can be hooked up with wires to the plated through holes marked +5VAIN, +5VAIN1, -5VAIN, +5VDIN, +5VD1IN, +5VD2IN, -5VDIN, AGND and DGND near the analog prototyping area. +5VDIN, +5VD1IN, +5VD2IN and -5VDIN are digital supplies and should be returned to DGND. +5VAIN, +5VAIN1 and -5VAIN are the analog supplies and should be returned to AGND. Table 1 lists the operational supply voltages, typical current consumption and the evaluation board circuit function being powered. Single supply operation of the converter is possible but the overall performance of the converter may degrade.

**TABLE 1. HI5805 EVALUATION BOARD POWER SUPPLIES**

POWER SUPPLY	NOMINAL VALUE	CURRENT (TYP)	FUNCTION(S) SUPPLIED
+5VAIN	5.0V ±5%	22mA	Op Amps
+5VAIN1	5.0V ±5%	46mA	A/D AV <sub>CC</sub>
-5VAIN	-5.0V ±5%	22mA	Op Amps
+5VDIN	5.0V ±5% <sup>3</sup>	43mA	CLK Comparator, D0-D11 D-FF
+5VD1IN	5.0V ±5%	13mA	A/D DV <sub>CC1</sub> and DV <sub>CC2</sub>
+5VD2IN	5.0V ±5%	1mA	A/D DV <sub>CC3</sub>
-5VDIN	-5.0V ±5%	3mA	CLK Comparator

It should be noted that overdriving the analog input beyond the ±2.0V fullscale input voltage range will not damage the converter as long as the overdrive voltage stays within the converters analog supply voltages. In the event of an overdrive condition the converter will recover within one sample clock cycle.

### Sample Clock Driver, Timing and I/O

In order to ensure rated performance of the HI5805, the duty cycle of the sample clock should be held at 50% ±5%. It must also have low phase noise and operate at standard TTL levels.

A voltage comparator (U3) with TTL output levels is provided on the evaluation board to generate the sampling clock for the HI5805 when a sinewave (< ±3V) or squarewave clock is applied to the CLK input (J1) of the evaluation board. A potentiometer (VR1) is provided to allow the user to adjust the duty cycle of the sampling clock to obtain the best performance from the ADC and to allow the user to investigate the effects of expected duty cycle variations on the performance of the

converter. The HI5805 clock input trigger level is approximately 1.5V. Therefore, the duty cycle of the sampling clock should be measured at this 1.5V trigger level. Test point TP4 provides a convenient point to monitor the sample clock duty cycle and make any required adjustments.

Figure 5 shows the sample clock and digital data timing relationship for the evaluation board. The data corresponding to a particular sample will be available at the digital data outputs of the HI5805 after the data latency time,  $t_{LAT}$ , of 3 sample clock cycles plus the HI5805 digital data output delay,  $t_{OD}$ . Table 2 lists the values that can be expected for the indicated timing delays. Refer to the HI5805 data sheet for additional timing information.

The sample clock and digital output data signals are made available through two connectors contained on the evaluation board. The line buffering provided by the data output latches allows for driving long leads or analyzer inputs. These data latches are not necessary for the digital output data if the load presented to the converter does not exceed the data sheet load limits of one standard TTL load and 10pF. The P1 I/O connector allows the evaluation board to be interfaced to the DSP evaluation boards available from Intersil. Alternatively, the digital output data and sample clock can also be accessed by clipping the test leads of a logic analyzer or data acquisition system onto the I/O pins of connector header P2.

**TABLE 2. TIMING SPECIFICATIONS**

PARAMETER	DESCRIPTION	TYP
$t_{OD}$	HI5805 Digital Output Data Delay	8ns
$t_{PD1}$	U3 Prop Delay	4.5ns
$t_{PD2}$	U5/6 Prop Delay	9ns

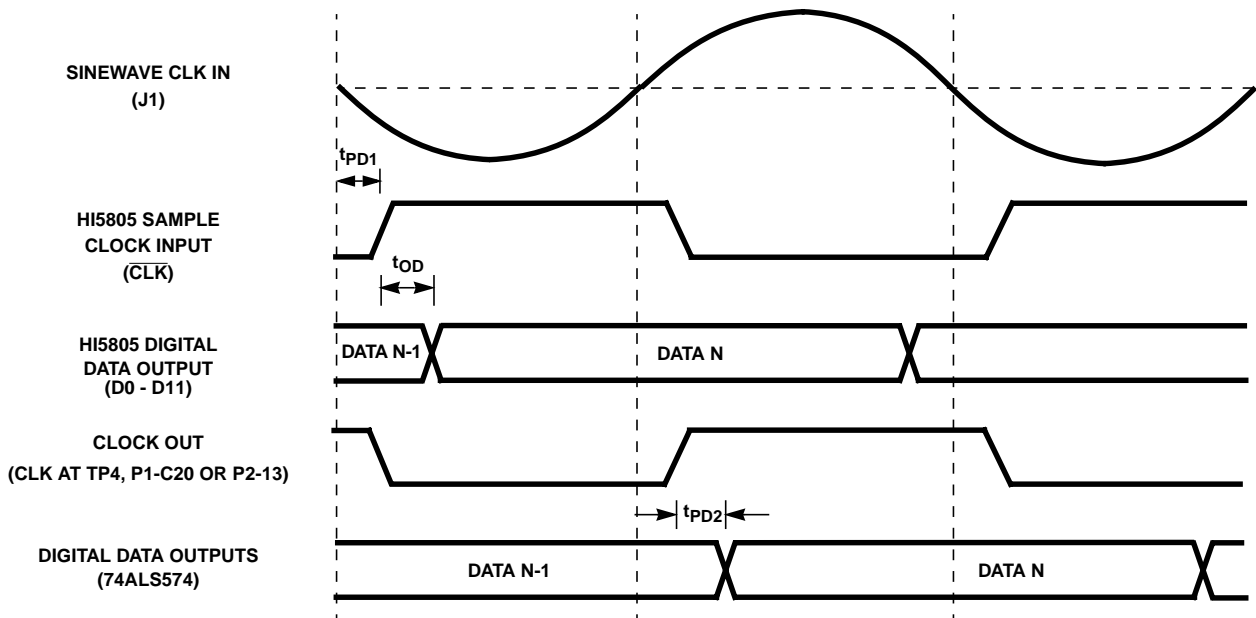

**FIGURE 5. EVALUATION BOARD CLOCK AND DATA TIMING RELATIONSHIPS**

### HI5805 Performance Characterization

Dynamic testing is used to evaluate the performance of the HI5805 A/D converter. Among the tests performed are Signal-to-Noise and Distortion Ratio (SINAD), Signal-to-Noise Ratio (SNR), Total Harmonic Distortion (THD), Spurious Free Dynamic Range (SFDR) and Intermodulation Distortion (IMD).

Figure 6 shows the test system used to perform dynamic testing on high-speed ADCs at Intersil. The clock (CLK) and analog input ( $V_{IN}$ ) signals are sourced from low phase noise HP8662A synthesized signal generators that are phase locked to each other to ensure coherence. The output of the signal generator driving the ADC analog input is bandpass filtered to improve the harmonic distortion of the analog input signal. The comparator on the evaluation board will convert the sine wave CLK input signal to a square wave at TTL logic levels to drive the sample clock input of the HI5805. The ADC data is captured by a logic analyzer and then transferred over the GPIB bus to the PC. The PC has the required software to perform the Fast Fourier Transform (FFT) and do the data analysis.

Coherent testing is recommended in order to avoid the inaccuracies of windowing. The sampling frequency and analog input frequency have the following relationship:  $F_I/F_S = M/N$ , where  $F_I$  is the frequency of the input analog sinusoid,  $F_S$  is the sampling frequency,  $N$  is the number of samples, and  $M$  is the number of cycles over which the samples are taken. By making  $M$  an integer and odd number (1, 3, 5, ...) the samples are assured of being nonrepetitive.

Refer to the HI5805 data sheet for a complete list of test definitions and the results that can be expected using the evaluation board with the test setup shown. Evaluating the part with a reconstruction DAC is only suggested when doing bandwidth or video testing.

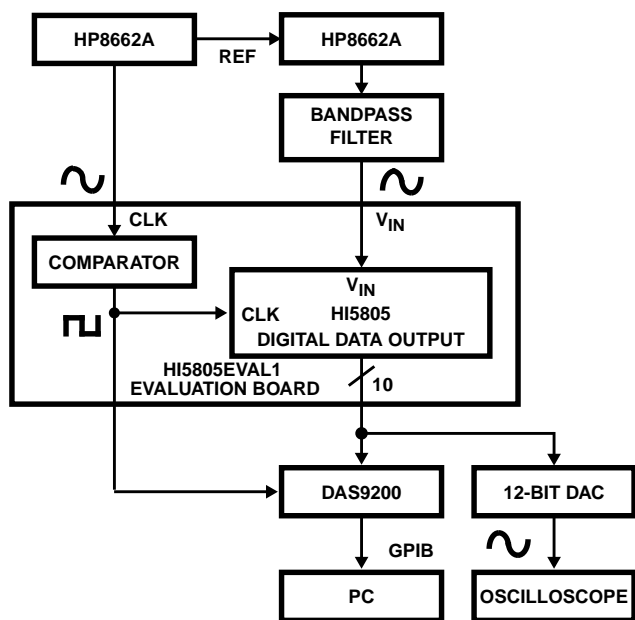

FIGURE 6. HIGH-SPEED A/D PERFORMANCE TEST SYSTEM

TABLE 3. HI5805 PIN DESCRIPTION

PIN NO.	NAME	DESCRIPTION
1	CLK	Input Clock
2	DV <sub>CC1</sub>	Digital Supply (5.0V)
3	D <sub>GND1</sub>	Digital Ground
4	DV <sub>CC1</sub>	Digital Supply (5.0V)
5	D <sub>GND1</sub>	Digital Ground
6	AV <sub>CC</sub>	Analog Supply (5.0V)
7	A <sub>GND</sub>	Analog Ground
8	V <sub>IN+</sub>	Positive Analog Input
9	V <sub>IN-</sub>	Negative Analog Input
10	V <sub>DC</sub>	DC Bias Voltage Output
11	V <sub>ROUT</sub>	Reference Voltage Output
12	V <sub>RIN</sub>	Reference Voltage Input
13	A <sub>GND</sub>	Analog Ground
14	AV <sub>CC</sub>	Analog Supply (5.0V)
15	D11	Data Bit 11 Output (MSB)
16	D10	Data Bit 10 Output
17	D9	Data Bit 9 Output
18	D8	Data Bit 8 Output
19	D7	Data Bit 7 Output
20	D6	Data Bit 6 Output
21	D <sub>GND2</sub>	Digital Output Ground
22	DV <sub>CC2</sub>	Digital Output Supply (3.0V to 5.0V)
23	D5	Data Bit 5 Output
24	D4	Data Bit 4 Output
25	D3	Data Bit 3 Output
26	D2	Data Bit 2 Output
27	D1	Data Bit 1 Output
28	D0	Data Bit 0 Output (LSB)

HI5805EVAL1 Typical Performance Curves

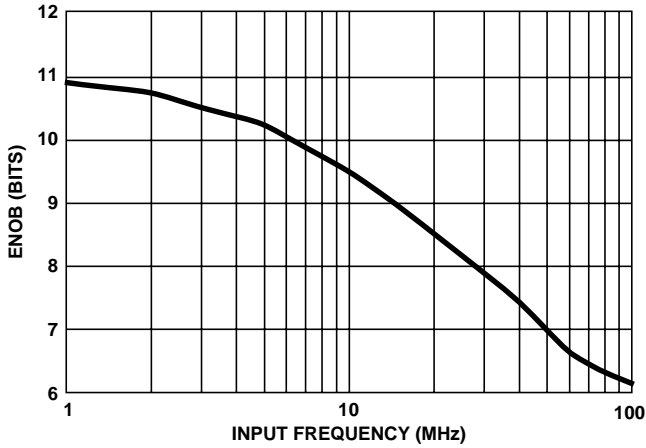

FIGURE 7. EFFECTIVE NUMBER OF BITS (ENOB) vs INPUT FREQUENCY

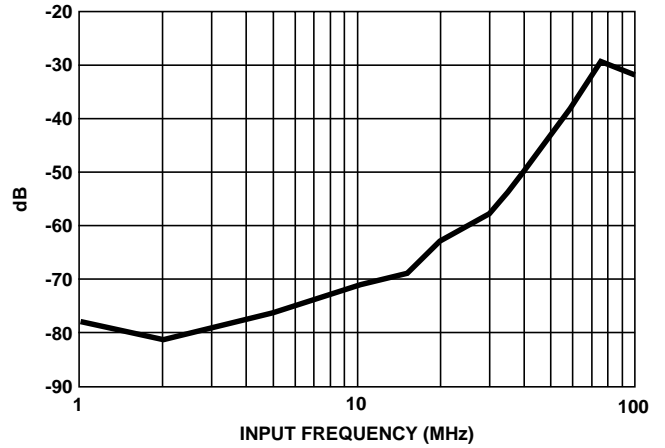

FIGURE 8. TOTAL HARMONIC DISTORTION (THD) vs INPUT FREQUENCY

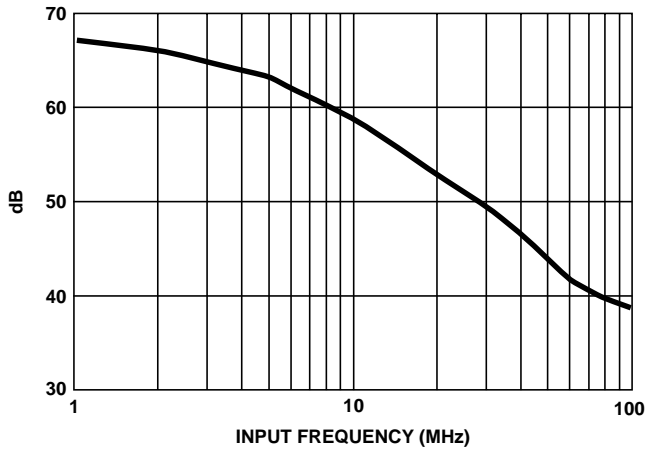

FIGURE 9. SINAD vs INPUT FREQUENCY

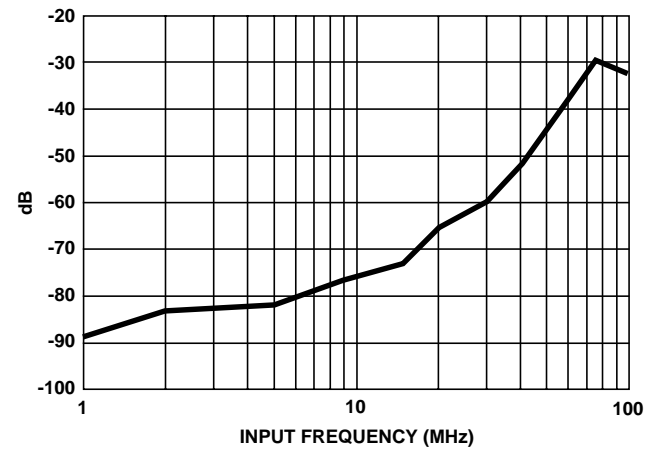

FIGURE 10. SECOND HARMONIC DISTORTION (2HD) vs INPUT FREQUENCY

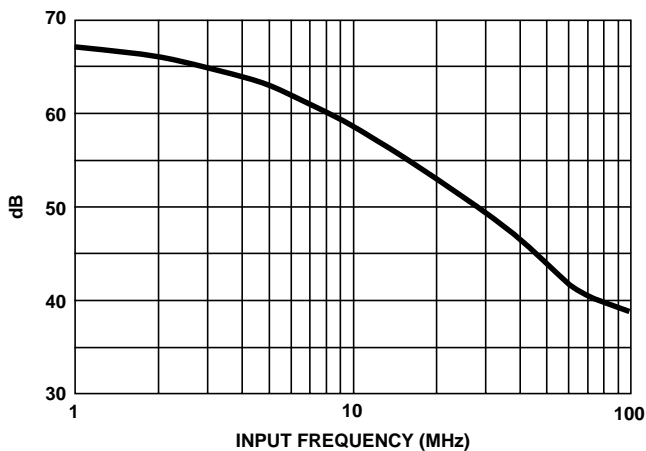

FIGURE 11. SNR vs INPUT FREQUENCY

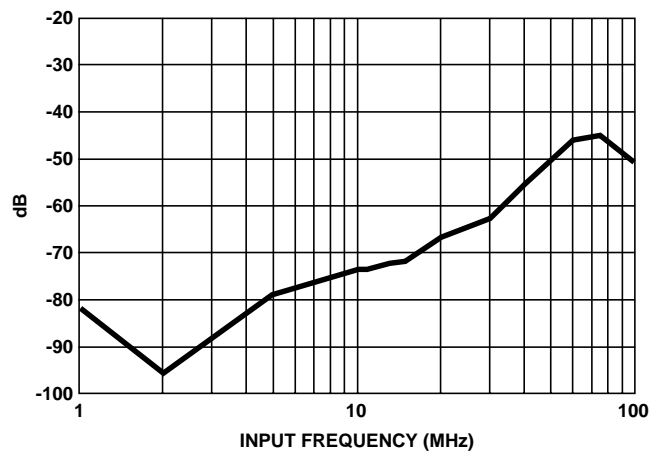

FIGURE 12. THIRD HARMONIC DISTORTION (3HD) vs INPUT FREQUENCY

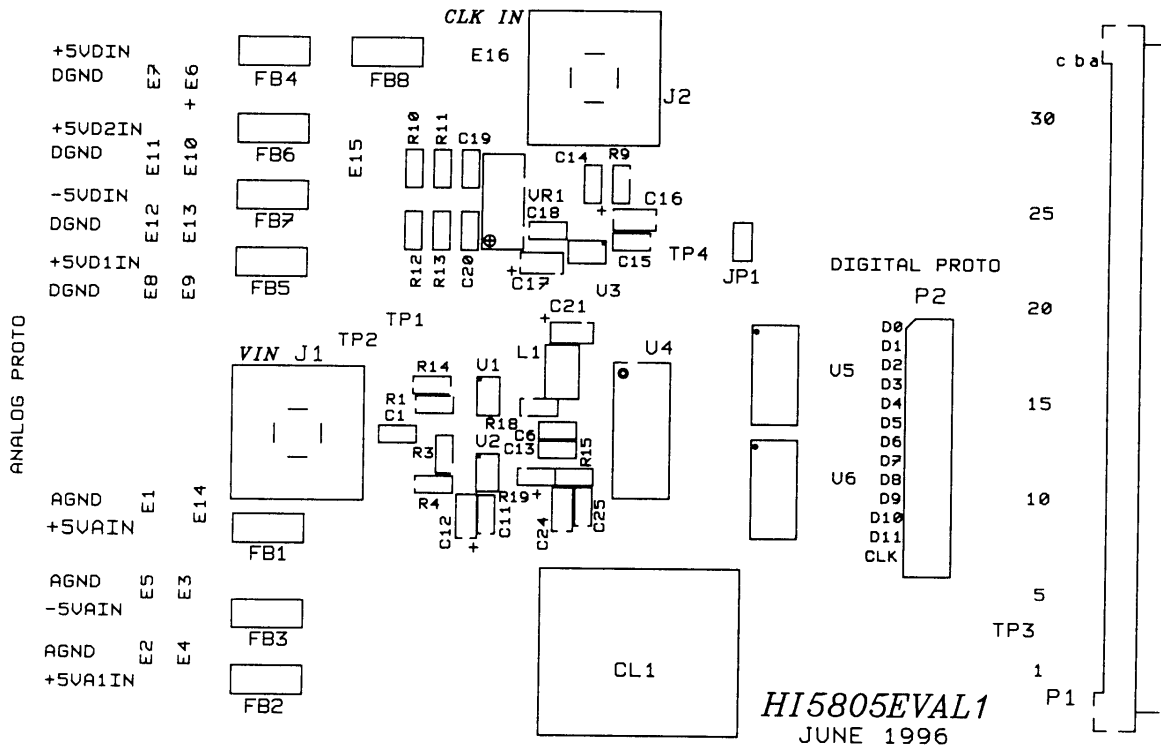

FIGURE 13. HI5805EVAL1 EVALUATION BOARD PARTS LAYOUT (NEAR SIDE)

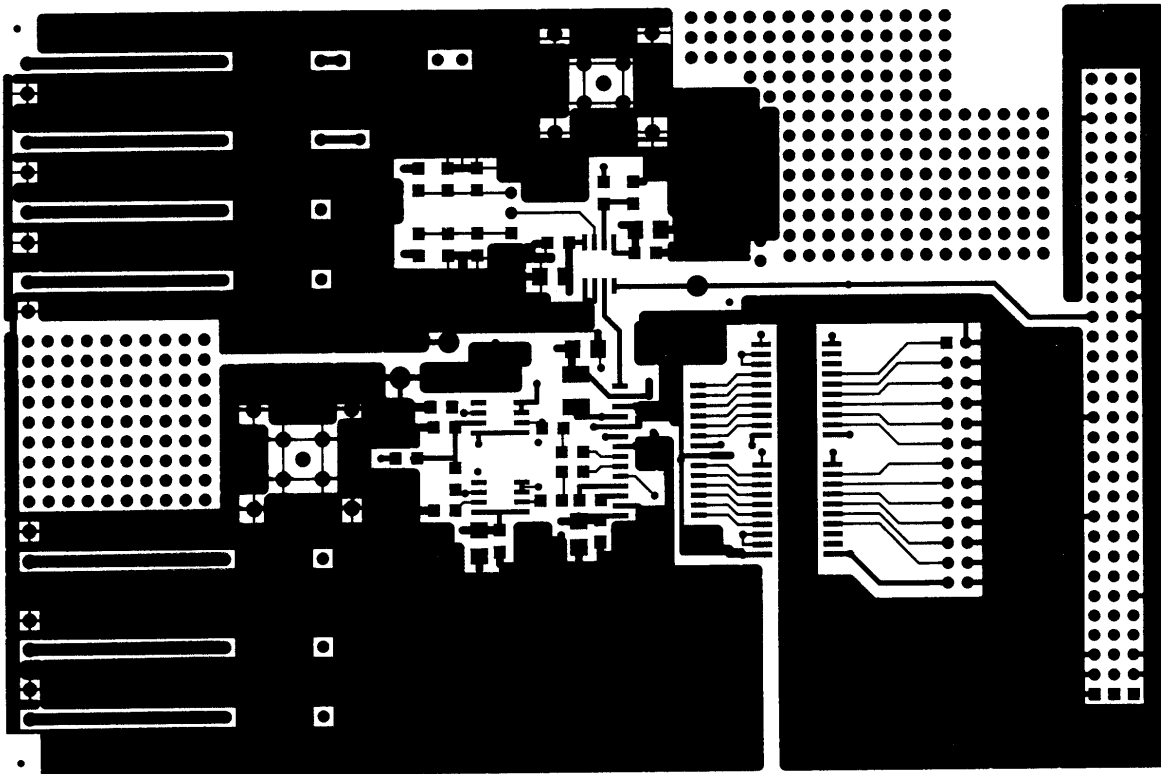

FIGURE 14. HI5805EVAL1 EVALUATION BOARD COMPONENT NEAR SIDE (LAYER 1)



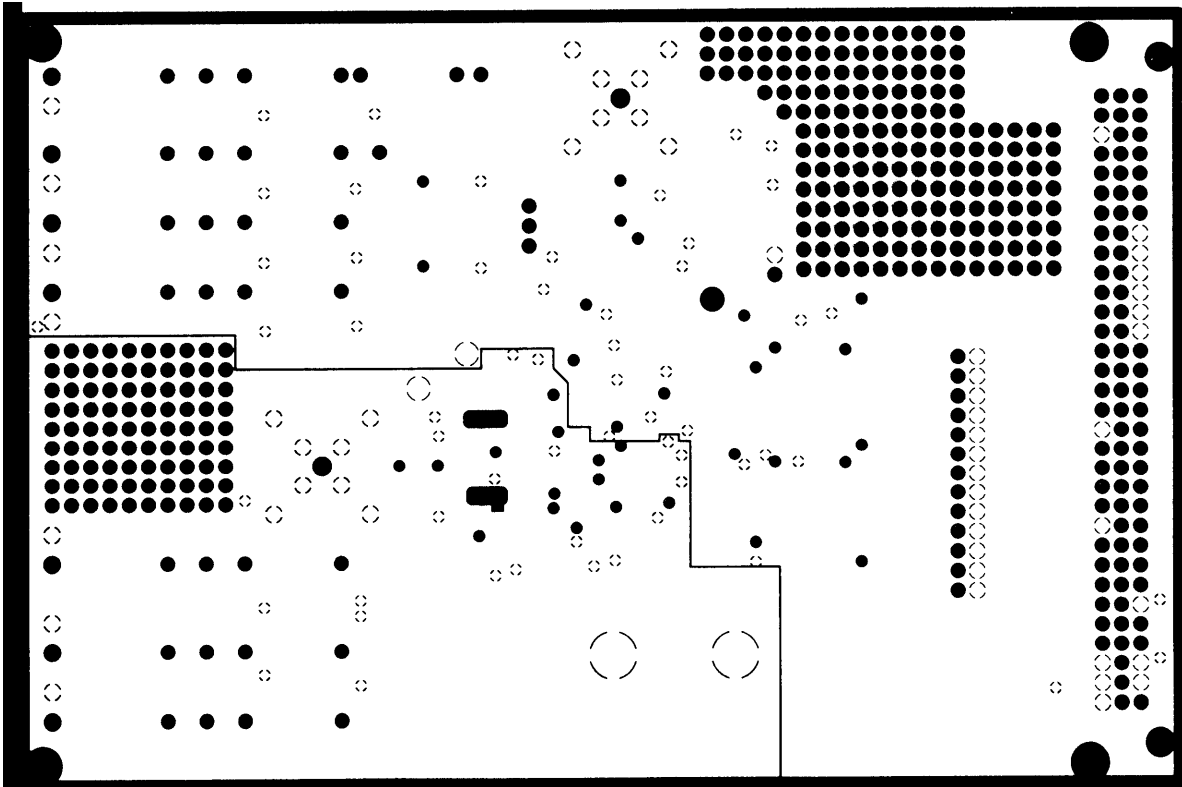

FIGURE 15. HI5805EVAL1 EVALUATION BOARD GROUND PLANE LAYER (LAYER 2)

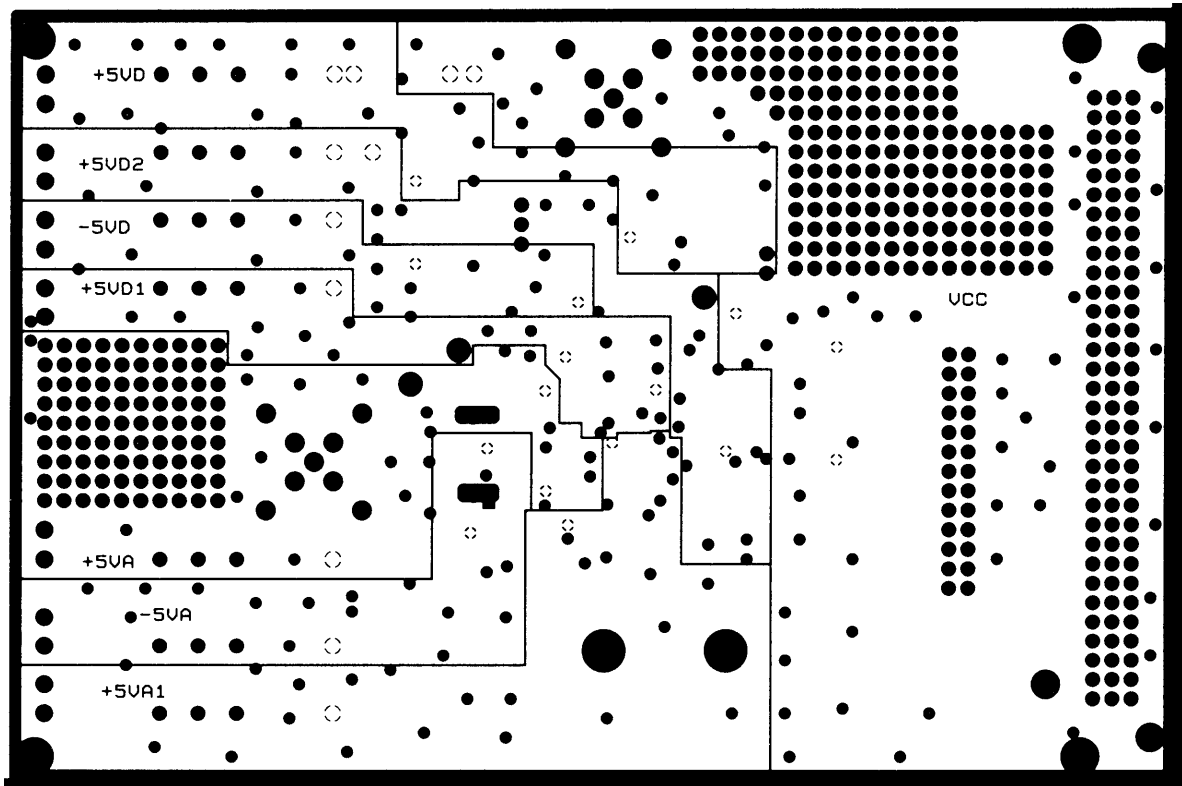

FIGURE 16. HI5805EVAL1 EVALUATION BOARD POWER PLANE LAYER (LAYER 3)

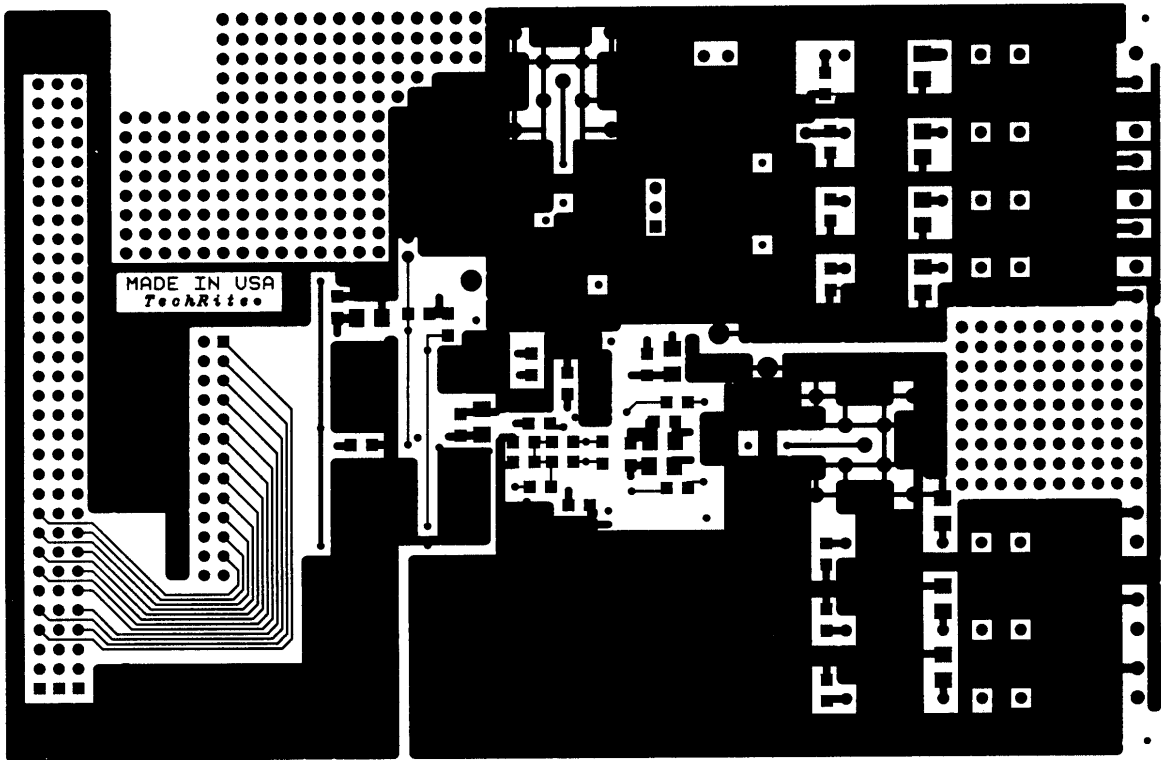

FIGURE 17. HI5805EVAL1 EVALUATION BOARD COMPONENT FAR SIDE (LAYER 4)

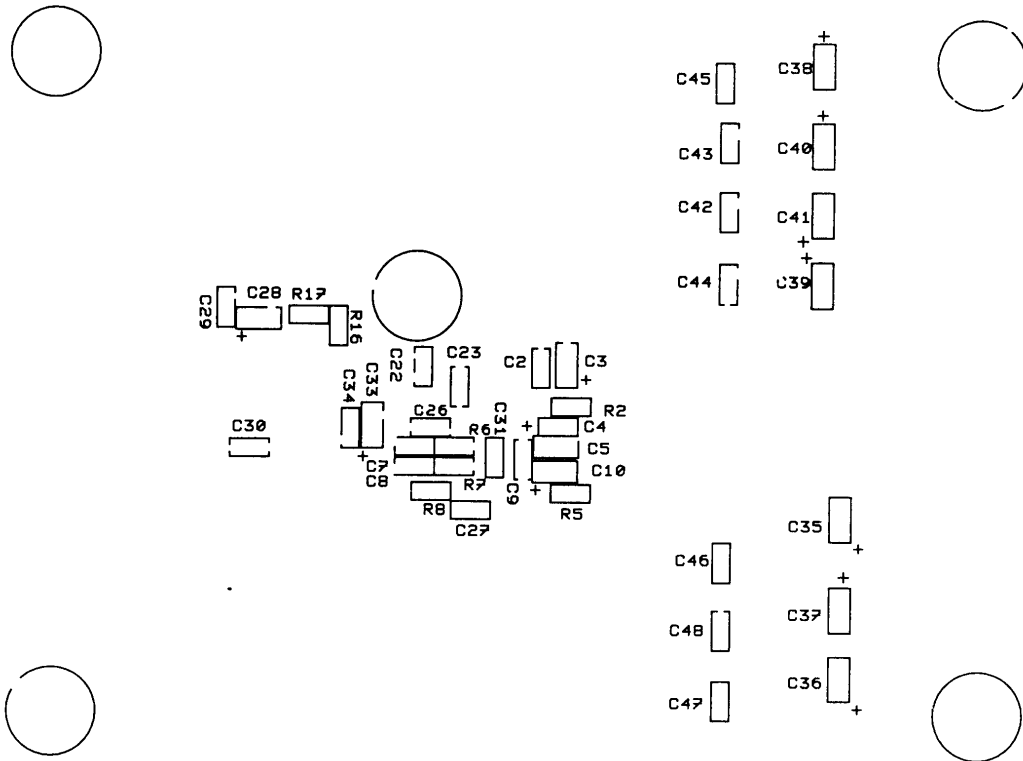
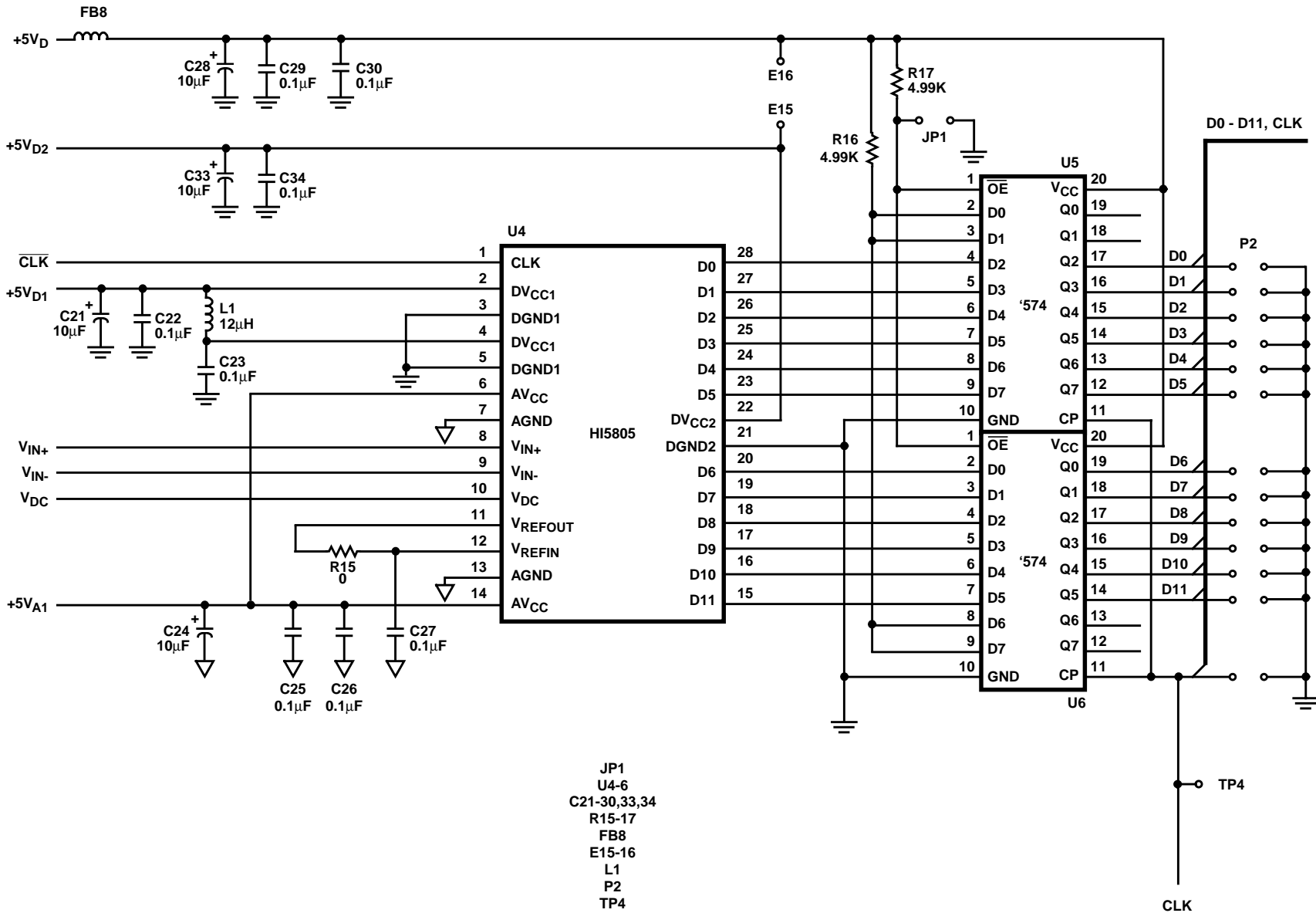
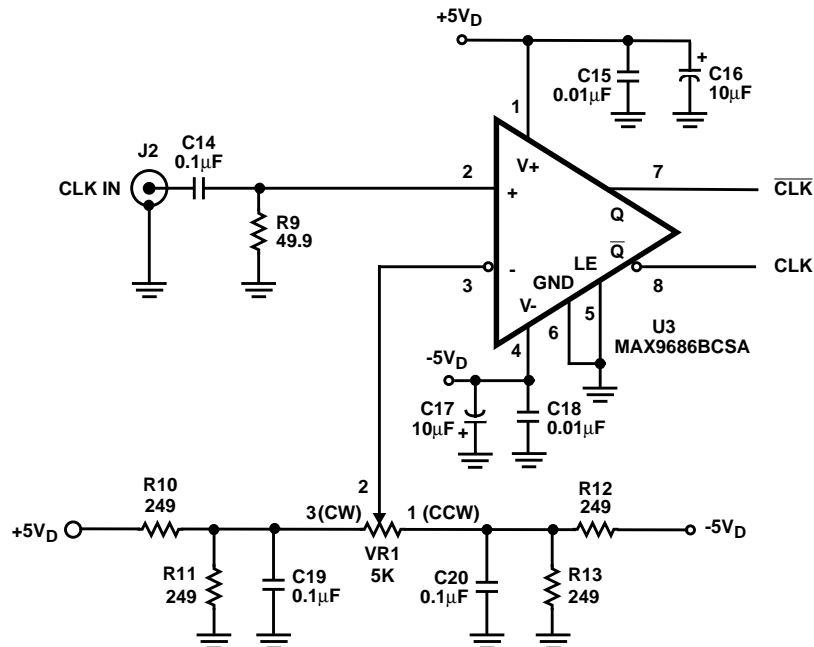
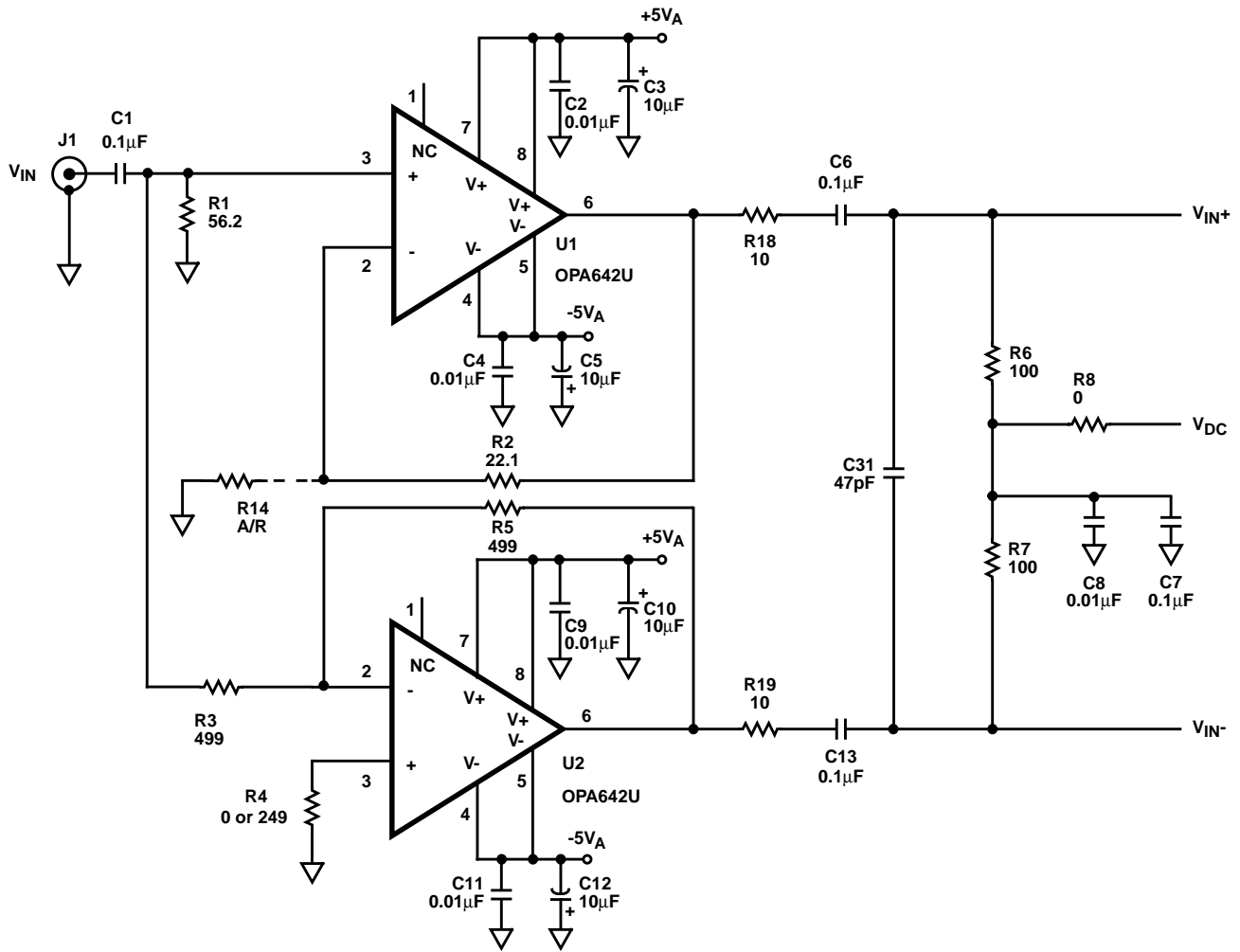

FIGURE 18. HI5805EVAL1 EVALUATION BOARD PARTS LAYOUT (FAR SIDE)



HI5805EVAL1 Evaluation Board Schematic Diagrams

HI5805EVAL1 Evaluation Board Schematic Diagrams (Continued)



J1-2  
U1-3  
C1-20,31  
R1-14,18,19  
VR1

HI5805EVAL1 Evaluation Board Schematic Diagrams (Continued)

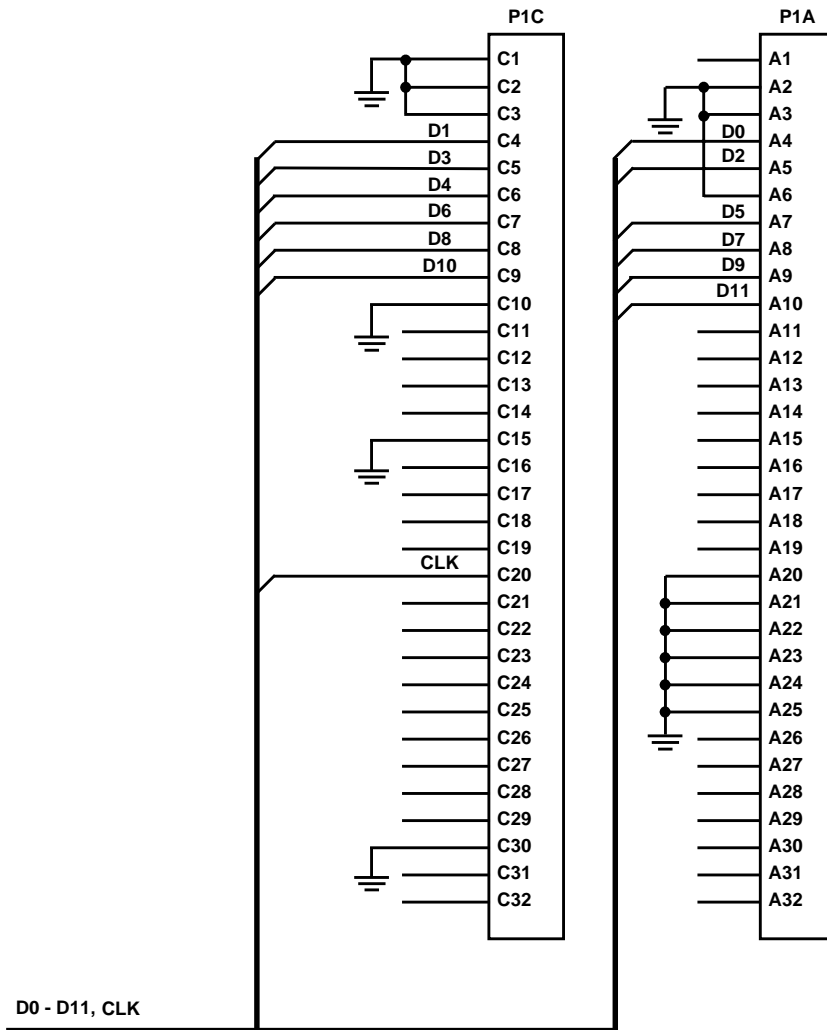

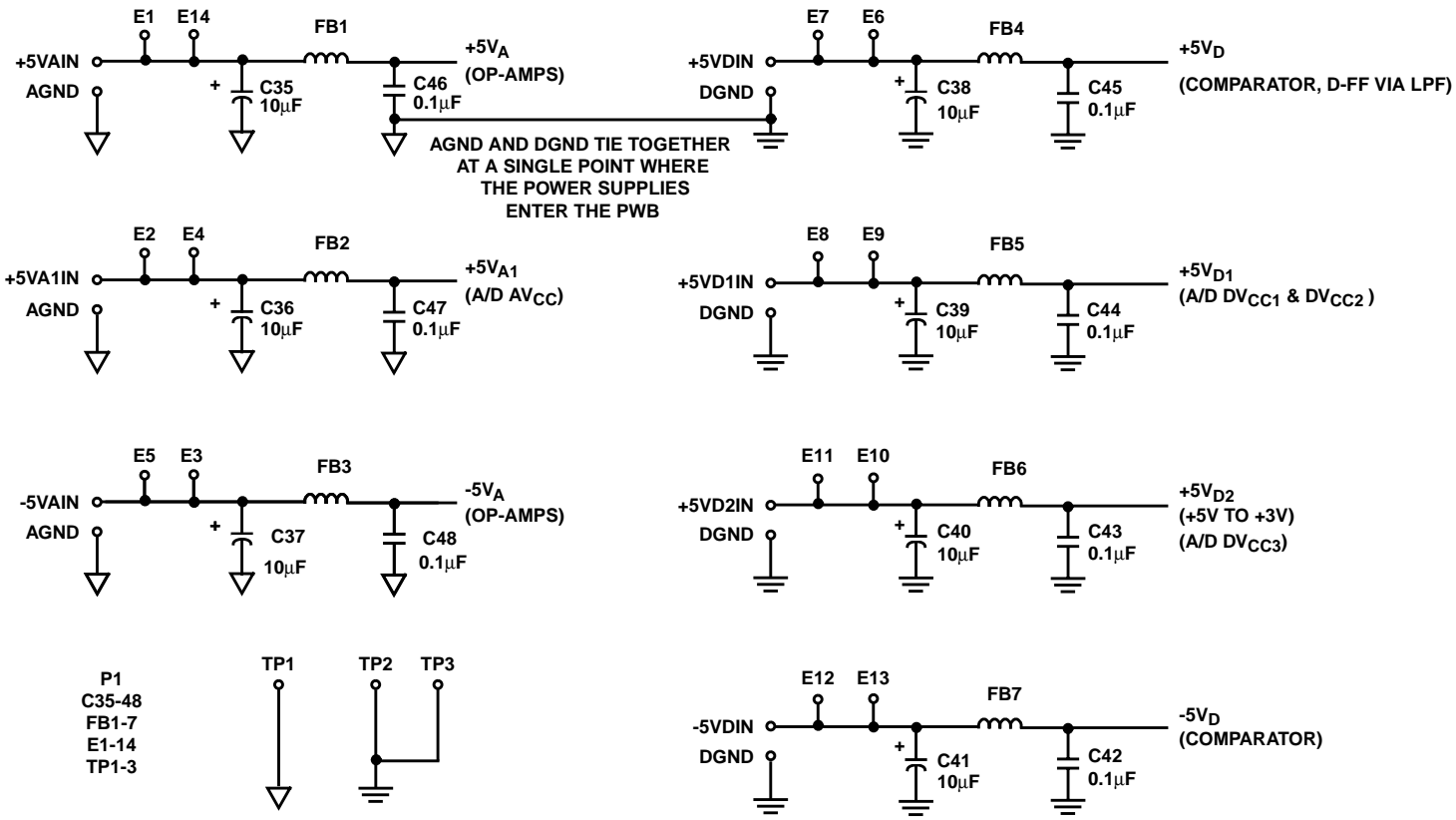

## Application Note 9707

### HI5805EVAL1 Evaluation Board Parts List

REFERENCE DESIGNATOR	QTY	DESCRIPTION
-	1	Printed Wiring Board
R1	1	56.2Ω, 1/8W 1206 Chip, 1%
R2	1	22.1Ω, 1/8W 1206 Chip, 1%
R3, 5	2	499Ω, 1/8W 1206 Chip, 1%
R4, 10, 11, 12, 13	5	249Ω, 1/8W 1206 Chip, 1%
R8, 15	2	0.0Ω, 1/4W 1206 Chip, 5%
R6, 7	2	100Ω, 1/8W 1206 Chip, 1%
R9	1	49.9Ω, 1/8W 1206 Chip, 1%
R16, 17	2	4.99kΩ, 1/8W 1206 Chip, 1%
R18, 19	2	10Ω, 1/8W 1206 Chip, 1%
R14	1	A/RΩ, 1/8W 805 Chip, 1%
VR1	1	5kΩ Trim Pot
C3, 5, 10, 12, 16, 17, 21, 24, 28, 33, 35-41	17	10μF Chip Tant Cap, 10WVDC, 20%, EIA Case B

REFERENCE DESIGNATOR	QTY	DESCRIPTION
C1, 6, 7, 13, 14, 19, 20, 22, 23, 25, 26, 27, 29, 30, 34, 42-48	22	0.1μF Cer Cap, 50WVDC, 10%, 1206 Case, X7R Dielectric
C2, 4, 8, 9, 11, 15, 18	7	0.01μF Cer Cap, 50WVDC, 10%, 1206 Case, X7R Dielectric
C31	1	47pF Cer Cap, 50WVDC, 5%, 1206 Case, NPO Dielectric
FB1-8	8	10μH Ferrite Bead
L1	1	12μH Shielded Chip Inductor, 1812 Case
J1, 2	2	SMA Straight Jack PCB Mount
-	5	Rubber Feet
JP1	1	1x2 Header
JPH1	1	1x2 Header Jumper
P2	1	2x13 Header
P1	1	64-Pin Eurocard RT Angle
TP1, 2, 3, 4	4	Test Point
U4	1	Intersil HI5805KCB, 12-Bit 5MSPS A/D Converter
U3	1	Ultrafast Voltage Comparator
U1, 2	2	Op Amp
U5, 6	2	Octal D-Type Flip-Flop

All Intersil semiconductor products are manufactured, assembled and tested under **ISO9000** quality systems certification.

*Intersil semiconductor products are sold by description only. Intersil Corporation reserves the right to make changes in circuit design and/or specifications at any time without notice. Accordingly, the reader is cautioned to verify that data sheets are current before placing orders. Information furnished by Intersil is believed to be accurate and reliable. However, no responsibility is assumed by Intersil or its subsidiaries for its use; nor for any infringements of patents or other rights of third parties which may result from its use. No license is granted by implication or otherwise under any patent or patent rights of Intersil or its subsidiaries.*

For information regarding Intersil Corporation and its products, see web site [www.intersil.com](http://www.intersil.com)