

HIP2105-6MBEVAL1Z

User's Manual: Evaluation Board

Industrial Analog and Power

HIP2105-6MBEVAL1Z

Evaluation Board

UG167
Rev.1.00
Jul 31, 2018

1. Overview

The HIP2105-6MBEVAL1Z is an evaluation tool for the [HIP2105](#) and [HIP2106A](#) half bridge MOSFET drivers. This tool consists of a mother board and HIP2105DBEVAL1Z or HIP2106ADBEVAL1Z evaluation daughter cards. The mother board platform provides an on-board microcontroller that is used to generate appropriate control inputs to the HIP2105 or HIP2106A. The frequency, the PWM duty cycle, and the dead time provided by the microcontroller are user adjustable.

For customers who want to provide their own external signals, the on-board controller can be configured to allow the daughter cards to be controlled by externally provided inputs.

The daughter cards can also be used as stand-alone units mounted on a customer designed main board that incorporates customer selected bridge FETs and any other external circuits desired. The daughter cards have optional circuits so that the HIP2105 or HIP2106A can be configured as required by the customer's application.

1.1 Key Features

- Adaptive shoot-through protection, HIP2106A only
- HI/PWM and LI inputs, HIP2105 only
- 0.4Ω ON-resistance and 4A sink current capability
- Low tri-state hold-off time (20ns), HIP2106A only after 20ns
- Supports 3.3V and 5V HI/LI or PWM input
- Power-On Reset (POR)

1.2 Specifications

- Bridge Bias Voltage (V_{BAT}): 5V minimum, 25V maximum operating including transients
- External bias for microcontroller: 3.3V - 5.0V, ~30mA
- Maximum bridge current: 12A
- PWM switching frequency: 25kHz to 625kHz
- PWM duty cycle: Adjustable from 0% to ~ 98%
- Dead time: 0.0μs to 0.7μs in 100ns increments
- Large terminal blocks: 15A each connection
- Small terminal blocks: 6A each connection

1.3 Ordering Information

Part Number	Description
HIP2105-6MBEVAL1Z	HIP2105 and HIP2106A mother board
HIP2105DBEVAL1Z	HIP2105 evaluation board
HIP2106ADBEVAL1Z	HIP2106A evaluation board

1.4 Related Literature

For a full list of related documents, visit our website

- [HIP2105](#), [HIP2106A](#) product pages

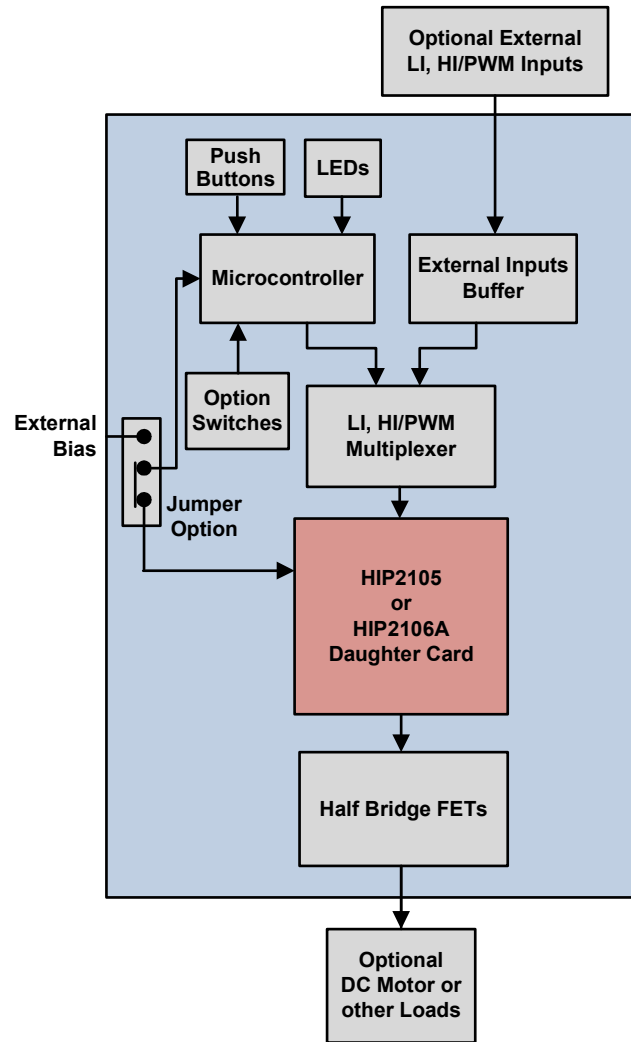

Figure 1. HIP2105-6MBEVAL1Z Block Diagram

2. Functional Description

The HIP2105-6MBEVAL1Z is a fully self-contained test platform for evaluation of the HIP2105 or the HIP2106A, which are provided on daughter cards.

The HIP2105-6MBEVAL1Z mother board and associated daughter cards are the same test boards used by the Renesas application engineers and IC designers to evaluate the performance of the HIP2105 and HIP2106A MOSFET drivers.

2.1 Scope

This user manual describes the use of the HIP2105-6MBEVAL1Z mother board and the HIP2105DBEVAL1Z and HIP2106ADBEVAL1Z daughter cards. A detailed description is provided for setting up and using the microcontroller. Assembly options on the motherboard are discussed, and sample waveforms are provided.

The microcontroller firmware is provided on request, but the only support offered by Renesas is for bug issues. Refer to [Microchip](#) for details on the use of the PIC18F2431.

2.2 Bias Supplies

The HIP2105-6MBEVAL1Z mother board requires a current limited lab supply (0V to 25V) for the V_{BAT} and GND inputs on TB1. The current capacity is dependent on the users desired load if any.

An external 5V bias supply (~25mA) is required for the microcontroller and associated circuits. This 5V bias supply for the microcontroller is supplied by an external source connected to TB8. The 5V bias for the HIP2105 and HIP2106A daughter cards must be supplied by an external source connected to VCC and GND of TB6.

2.3 Microcontroller and Associated Circuits

The PWM frequency and the dead time options of the microcontroller are configured by the SW5 DIP switch. Refer to the chart on the mother board schematic ([Figure 12 on page 16](#)) for the DIP switch settings, or to [Table 1 on page 10](#). The DIP switch settings are read only once after the Start/Stop button is pressed to start the PWM. Any changes to the frequency or dead time settings are not recognized until the PWM is stopped then restarted.

Turning the potentiometer, R1, fully Counter Clockwise (CCW) reduces the duty cycle of the output of the bridge to a minimum. Turning fully clockwise results with a maximum duty cycle. The duty cycle is proportional to the tap voltage of the potentiometer independent of the PWM frequency. The dead time subtracts from the duty cycle period on the leading edge of the HI/PWM and LI inputs to the daughter cards altering the actual duty cycle.

To emulate controllers that may be used by customers that do not have the ability to generate dead time, the dead time of the microcontroller can be set to zero. On the daughter cards, an optional RCD circuit is provided for the LI and HI/PWM inputs of the HIP2105 and HIP2106A to generate dead time.

Be cautious if the zero dead time option is selected when the HIP2105 and HIP2106A daughter cards are not configured for delays with the RCD circuit, as this results in shoot-through currents in the bridge.

Four LEDs are used to indicate the operating status of the microcontroller. Refer to [“Setup and Operating Instructions” on page 9](#) for complete details.

2.4 Half Bridge

The bridge is composed of two (NVTFS5C466NLWF) 51A, 40V MOSFETs. Each FET has an optional gate-to-source and drain-to-gate capacitors to allow the emulation of FETs with larger capacitances if desired. An optional series gate resistor is also provided for each bridge FET that can also be used to emulate the internal gate resistance. The current rating of these NVTFS5C466NLWF MOSFETs was chosen primarily to eliminate the need of a heat sink when operating with heavy current loads. The maximum output load current is constrained by the current rating of the VBAT (TB1) and the VOUT (TB7) terminal blocks. If a load current higher than 15A is desired, it is recommended that the battery and load wires are soldered directly to the solder pads of the TB1 and TB2 terminal blocks on the bottom of the PCB.

The bridge bias source is connected to the VBAT terminal block (TB1). The voltage source can be either a current limited power supply (recommended for initial setup) or a battery (a fuse is highly recommended).

An external load can be connected to the VOUT (TB7) terminal block. The load can be of any configuration (for example a DC motor or an LCR load) as desired by the user within the constraints of the bridge FETs and the terminal blocks.

Even though the FETs have a voltage rating of 40V, the maximum operating voltage is limited to 25V by the rating of the Phase and VBAT pins on the HIP2105, HIP2106A drivers.

2.5 Daughter Cards

Two different daughter cards are provided for evaluation. These cards are mounted on the back side of the mother board to facilitate temperature testing using a temperature forcing system.

The HIP2105DBEVAL1Z and HIP2106ADBEVAL1Z daughter cards are identical except for the differences between the HIP2105 and the HIP2106A.

When using the HIP2105 daughter card, VCC must come from external sources. As mentioned previously, the J2 strap option is used to select the bias source for the microcontroller. If the 5V strap option is selected, the bias to the microcontroller is always present. This is desirable during the initial setup of the evaluation board or when testing the HIP2105 for varying the V_{CC} to the driver.

2.6 Switches and Push Buttons

Three push buttons provide control signals to the microcontroller. The reset button restarts the firmware. The Start/Stop button starts and stops the PWM signals to the LI and HI inputs of the HIP2105, and PWM input to the HIP2106A.

2.7 User Assembly Options

The following optional assembly features are provided on the evaluation mother board:

- Series connected diode (D1) on the VBAT input to the HIP2106A daughter card for holding up V_{BAT} when there is severe ripple voltage from a Li-ion battery. A 0Ω resistor (R_{23}) shorts out this diode when not required (installed).

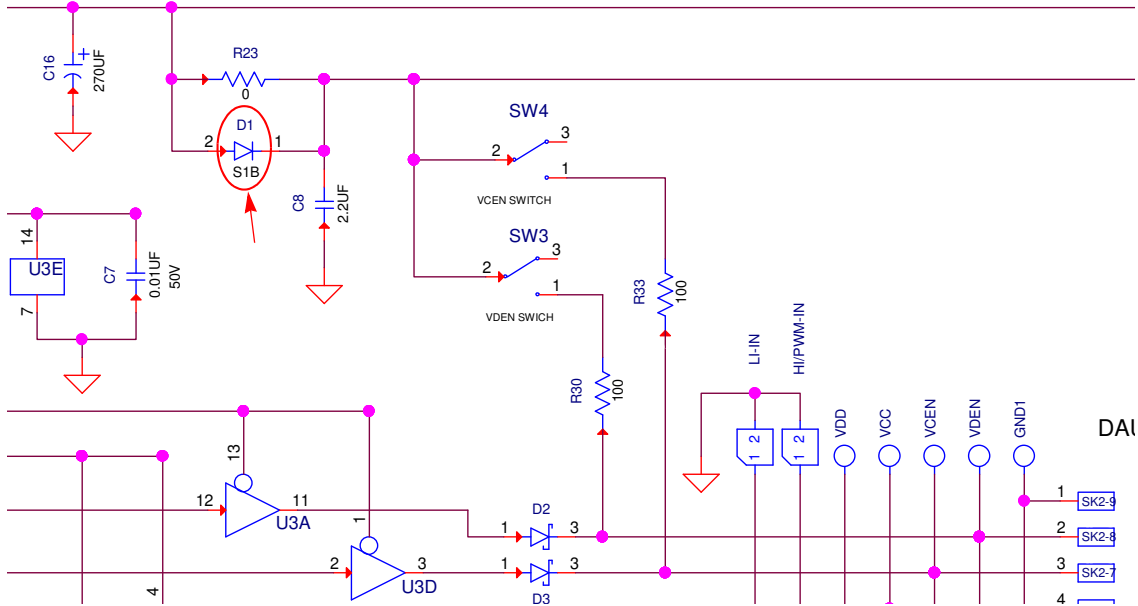

Figure 2. Diode to Suppress Li-Ion Battery Ripple

- Gate-to-source resistors on the bridge FETs. (R_{19} and R_{21} are omitted)
- Series connected gate resistors on each bridge FET (R_{34} and R_{35} are installed with 0Ω)
- Gate-to-source, and gate-to-drain capacitors on the bridge FETs (C_{11} , C_{12} , C_9 , and C_{10} omitted). The capacitors can be added to emulate larger FETs.

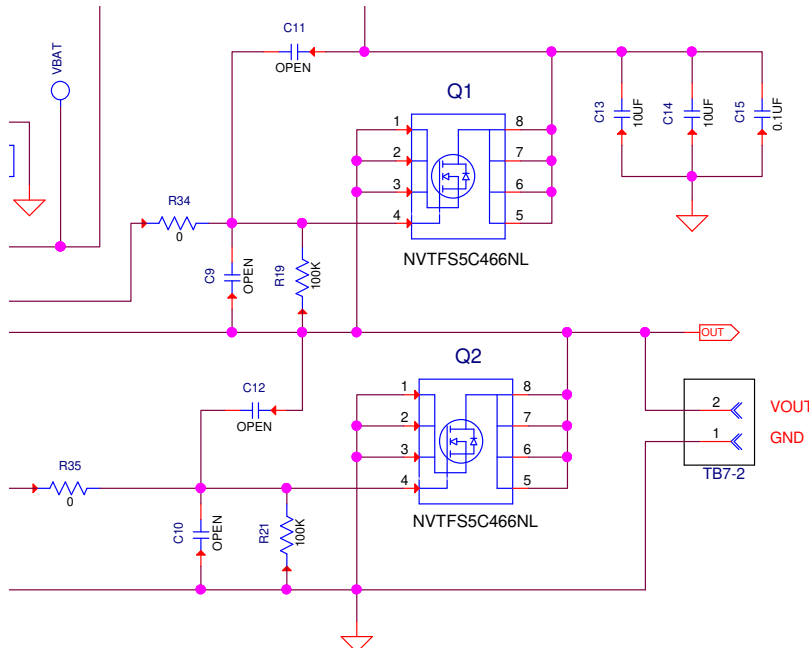

Figure 3. Optional Resistors and Capacitors for Bridge FETs

The following user optional assembly features are provided on the HIP2105, HIP2106A daughter cards.

- The HO = HGATE and LO = LGATE outputs have options for a bypass diode across a series connected gate resistor for slower turn-on and faster turn-off of the driven bridge FET. The default configuration includes the bypass diode in parallel with a 0Ω resistor.

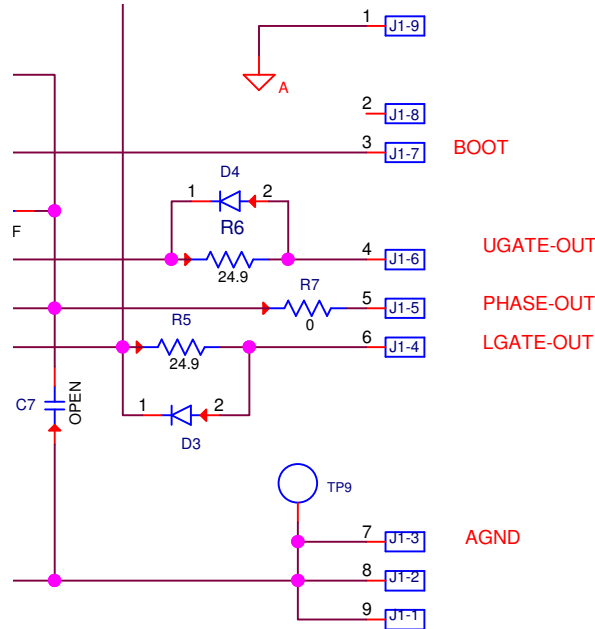

Figure 4. Bypass Diodes (D3, D4) for Slow Turn-On and Fast Turn-Off

- The LI and HI/PWM inputs have optional RCD circuits for the purpose of generating dead time if a controller is used that does not have built-in dead time capability. As previously mentioned, the on-board microcontroller can be configured for no dead time delays. The default configuration includes Schottky diodes in parallel with a 0Ω resistor.

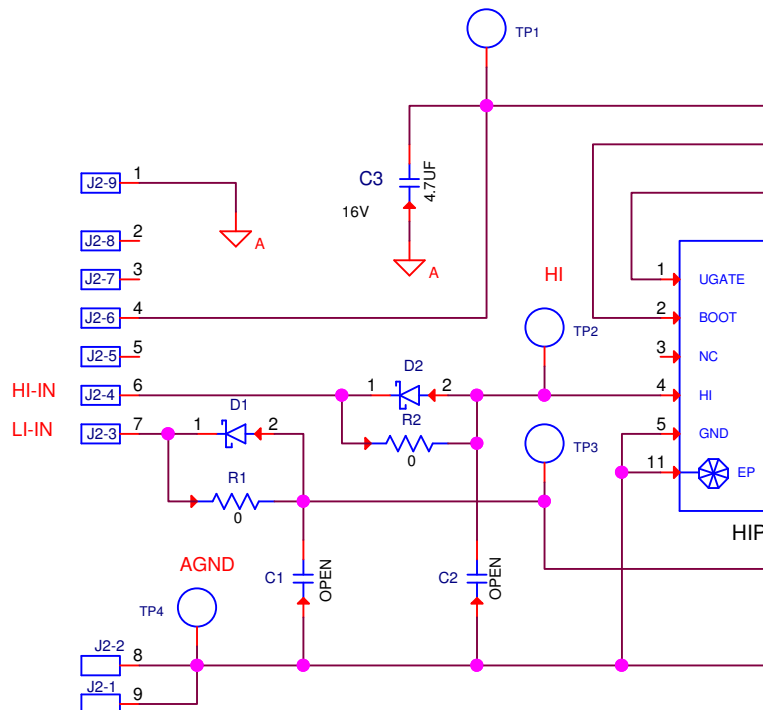

Figure 5. Bypass Diodes (D1, D2) Used for Dead Time Generation

- The PHASE pin has an RC filter (R_7/C_7 on the HIP2105 daughter card and R_7/C_9 on the HIP2106A daughter card) This filter is used if needed. The default value for R_7 is 0Ω and the capacitor between Phase and VSS is omitted.

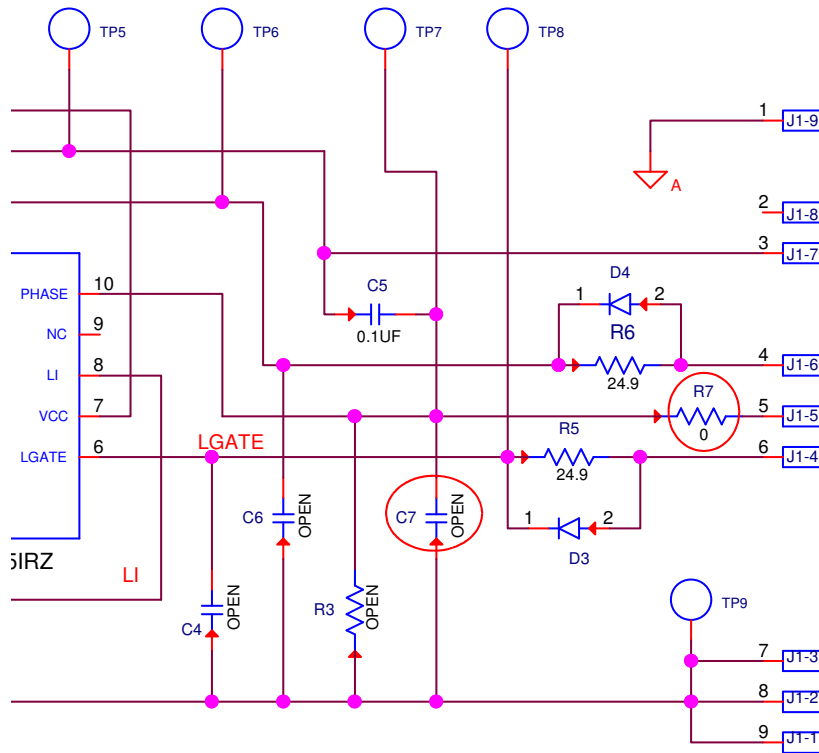

Figure 6. RC Filter on PHASE Pin (not required)

2.8 Switching Transients

The recommended maximum operating voltage on the PHASE and VBAT pins is 25V. This **includes** the switching transients resulting from parasitic inductance in the bridge circuit.

A similar transient situation may occur with the Phase pin. In this situation, a ringing spike can be more severe because of high speed switching from the bridge FETs, the large amplitude of switching currents, and because of parasitic inductance associated with the bridge high current PCB traces. Because the amplitude of the ringing spike also increases with the switching load current amplitude, evaluation should be across the full operating load range including fault currents. Good bridge circuit PCB design minimizes but cannot totally eliminate ringing on the Phase node.

These switching transients are relatively fast. When evaluating the spikes on these pins, it is necessary to use a time base on the scope of about 100ns/division. Slower sweep speeds may mask the switching spike depending on the sample rate of the digital scope.

Other methods can also be used to reduce ringing on the Phase node. Sufficiently large value gate resistors on the bridge FETs reduce the switching speed and consequently the amplitude of the ringing. The above mentioned RC filter on the Phase pin can also be used to attenuate the spike directly on the Phase pin. By default, the gate resistors on the HIP2105/6A daughter cards, R_5 and R_6 , is 0Ω . With this evaluation PCB layout, 0Ω is sufficient to prevent excessive switching transient, but a user's PCB layout may require more or less gate resistance or another method to attenuate the switching transients.

Another source of switching transients that must be dealt with is from the bridge voltage source, especially with Li-ion batteries. When the Li-ion battery load current is interrupted when the bridge turns off, the voltage from the battery can rise dramatically because of the internal inductance of the battery. The usual solution is to have sufficiently large capacitance across the bridge. This bridge bypass capacitor is effectively an LC filter working

with the internal inductance of the Li-ion battery (typically a few hundred nH). If the capacitor value is large enough, the battery voltage is close to the nominal unloaded value with minimal ripple. Another approach to reduce the amplitude of the voltage transient from the battery without increasing the size or value of the bridge capacitor, is to increase the PWM switching frequency.

If it is not desirable to use relatively large value capacitors across the bridge, a clamping method must be used to limit the peak voltage ripple from the battery. In any case, a relatively small capacitor across the bridge should be used to limit the rate of change of the ripple voltage and to minimize the effects of the PCB parasitic trace inductance on the Phase pin.

Another consequence of allowing a relatively large ripple voltage on the battery, is that under heavy load conditions, the voltage ripple valley drops to very low levels. Because most motor loads respond to the average voltage applied, this ripple voltage is of minimal concern. If the valley voltage drops too low, the UVLO of the HIP2105/4 is 3.0V typical. If the bridge FETs are selected appropriately, this low-gate drive voltage has no significant effect except for the usual consequence of higher $r_{DS(ON)}$ of the bridge FETs.

2.9 Setup and Operating Instructions

The following procedures ensure a correct setup of the evaluation board and illustrate various operating methods.

2.9.1 Required Lab Equipment

- Power supply (or battery), 13V minimum to 25V maximum operating for the bridge bias. The current rating of the power supply must have sufficient capacity for the external load used for testing (if any). If no load is applied, 200mA is sufficient. If a battery is the power source, it is highly recommended that an appropriate fuse be used. With a Li-ion battery, it is necessary to add sufficient capacitance (100 μ F or greater) across the VBAT terminal block to prevent excessive ringing.
- Bias supply, 5V at ~50mA, required for testing the HIP2105 or HIP2106A
- Bench fan (only necessary when testing with large loads at elevated ambient temperatures)
- Four channel oscilloscope, ~500MHz recommended
- Current probe (optional) when testing with external loads
- Multimeter

2.9.2 Initial Configuration for the Microcontroller

The following procedure illustrates how to configure the microcontroller without applying power to the bridge.

- (1) Connect a 5.0V bias supply to the +5V_GND terminal block (TB8). This voltage powers the microcontroller.
- (2) Ensure that the jumper strap on J2 is on the 5V option. This connects the microcontroller to the external lab supply.
- (3) Set up the DIP switch on the mother board with the desired PWM frequency and dead time. For the initial setup, start with 200kHz and 100ns dead time (in bold type).

Table 1. DIP Switch Options

Switch Position	6	5	4	3	2	1	
PWM Frequency	x	x	x	0	0	0	25kHz
	x	x	x	0	0	1	50kHz
	x	x	x	0	1	0	100kHz
	x	x	x	0	1	1	200kHz
	x	x	x	1	0	0	300kHz
	x	x	x	1	0	1	400kHz
	x	x	x	1	1	0	500kHz
	x	x	x	1	1	1	625kHz
External inputs	1	1	1	1	1	1	
Dead Time	0	0	0	x	x	x	0.0µs
	0	0	1	x	x	x	0.1µs
	0	1	0	x	x	x	0.2µs
	0	1	1	x	x	x	0.3µs
	1	0	0	x	x	x	0.4µs
	1	0	1	x	x	x	0.5µs
	1	1	0	x	x	x	0.6µs
	1	1	1	x	x	x	0.7µs

- (4) Connect scope probes on the HI/PWM and LI test points on the mother board. Set the time base to 50ns/Div, the vertical gain to 2V/Div, the trigger on the LI input at the 2.5V level with a negative edge trigger, and the trigger position at the 100ns division (on the left side of the screen) and use the auto trigger mode.
- (5) Turn the duty cycle potentiometer, R₁, fully counter clockwise until it clicks.
- (6) Turn on the lab supply. Observe that the four LEDs turn on and off, one after another. This flashing sequence indicates that power has been applied. After the initial flash, all LEDs are off.

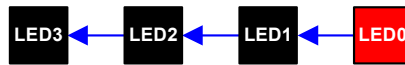

At initial turn on, LEDs will turn on and off one at a time starting with LED0

- (7) Observe that the LI and HI/PWM inputs are low.
- (8) Press the Start/Stop push button once. The Run LED (LED0) blinks indicating that PWM signals from the controller have been enabled.

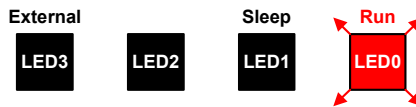

With PWM signals present on LI and HI, the Run LED is blinking

The DIP switch options are read only when the Start/Stop button is pressed to start the PWM signals. Changing the settings while the Run LED is flashing has no effect. To update the DIP switch setting, change the setting, stop the PWM signals, then start again.

- (9) Slowly rotate the potentiometer, R_1 , to the right (CW) until the waveforms shown in [Figure 7](#) appear.

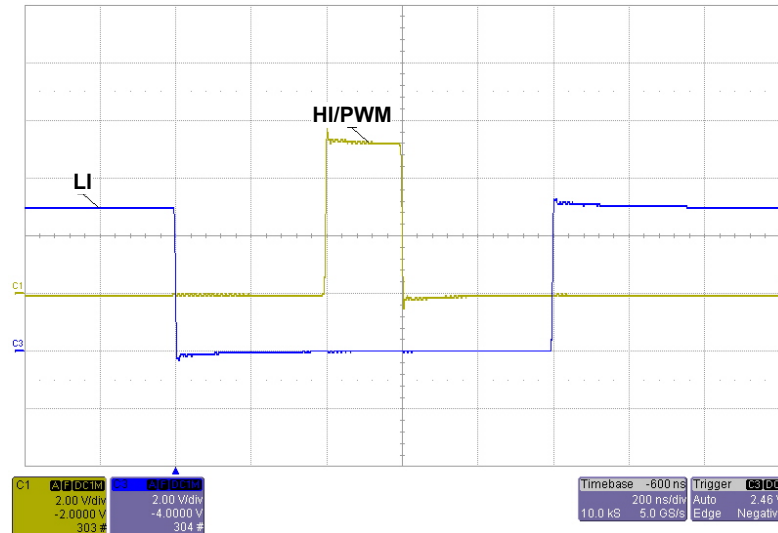

Figure 7. HI/PWM and LI Signals

- (10) Confirm that a the preset dead time is present.
- (11) Rotate the potentiometer CCW to zero the PWM period.
- (12) Press the Start/Stop push button to disable the PWM outputs. The blinking LED0 turns off.
- (13) Press the Sleep button. LED1 turns on to indicate that Sleep mode is active.
- (14) Press the Start/Stop button. LED0 flashes indicating that the PWM outputs are active. Simultaneously, LED1 turns off indicating that Sleep mode is no longer active.
- (15) Press the Sleep button. LED0 turns off and LED1 turns on indicating that Sleep mode is active.

2.9.3 Initial Setup to Evaluate the HIP2105 Daughter Card

The following procedure illustrates how to setup the HIP2105 daughter card and apply power to the bridge.

- (1) Install a HIP2105 daughter card on the mother board. Be careful with the polarity.
Incorrect installation may damage the daughter card and the mother board.
- (2) Connect an additional scope probe to the Phase test point on the mother board. Set the vertical gain to 10V/Div and the time base to 10 μ s/Div.
- (3) Connect 5V supply to VCC and set the output to OFF
- (4) Connect the bridge power supply to the VBAT_GND terminal block (TB1).
- (5) Starting with an initial output of 20V and a current limit of 200mA, turn on the bridge supply.
Caution: If a Li-ion battery is used instead of a regulated supply, it is recommended to add a 100 μ F or larger capacitor across the VBAT input terminal. This is necessary because the relatively large inductance of an Li-ion battery can resonate with the bridge bypass capacitor resulting with excessive voltage.
- (6) Turn on $V_{CC} = 5V$.
- (7) Measure 12V \pm 5% on the VDD pin of TB6 relative to the GND pin.
- (8) Press the Reset button. The four LEDs flash one after another, and then turn off.
- (9) Press the Start/Stop button. LED0 is flashing and HI/PWM and LI signals are active.

- (10) Turn the potentiometer CW until the waveform shown in [Figure 8](#) appears.

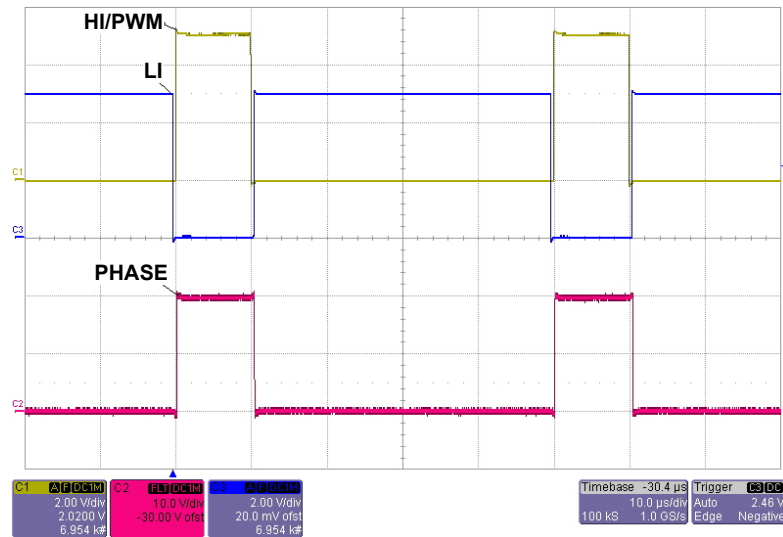

Figure 8. HI/PWM, LI, and Phase Signals

- (11) Confirm that the PWM frequency is 200kHz on the HI/PWM and LI pins.
 (12) Turn on the bridge supply (still at 20V).
 (13) Press the Start/Stop button. The LI and HI/PWM inputs start switching. The Phase output is also switching.
 (14) Turn off V_{CC} . Phase stops switching.

2.10 Initial Setup to Evaluate the HIP2106A Daughter Card

The method to evaluate the HIP2106A is similar to the HIP2105 except only the PWM signal is provided as an input to the HIP2106A. TB6 input terminal for VCC bias for the HIP2105 and HIP2106A. VCC on TB6 can also be used as a bias input for the microcontroller (or alternatively TB8).

2.11 DIP Switch Configuration for Testing with External Signals

It may be desirable to provide control signals from an off-board controller or logic generator.

- (1) Configure the DIP switch for external signals (all switches on), see [Table 1 on page 10](#).
 (2) Press the START/STOP button. Observe that LED3 (External) is on.



LED3 is on when configured for external inputs

- (3) The U3 buffer on the mother board is now in the tri-state mode. All inputs, VCEN, VDEN, HI/PWM, LI must now come from an external controller. Terminal blocks GND_VDEN_VCEN (TB5), and HI_LI (TB4) are used for these inputs.

3. PCB Layout Guidelines

The HIP2105-6MBEVAL1Z board is 84mmx94mm. The tallest component is the RJ25 connector. The total height is 38mm. Multiple inputs have miniature terminal blocks and the high current battery inputs and load outputs have larger terminal blocks rated for 15A each connection. Three push-buttons are used for Reset, Start/Stop, and Sleep functions. An on-board potentiometer adjusts the duty cycle.

The six position DIP switch sets up the PWM switching frequency (Positions 1, 2, and 3) and the dead time (Positions 4, 5, and 6). One specific combination of DIP switch settings (all positions set to on) disables the signals from the microcontroller and enables all of the external inputs.

For users who want to modify the firmware of the PIC18F2431 microcontroller, an RJ25 connector is provided for easy connection with Microchip firmware development tools (not provided or supported by Renesas).

3.1 HIP2105-6MBEVAL1Z Evaluation Board

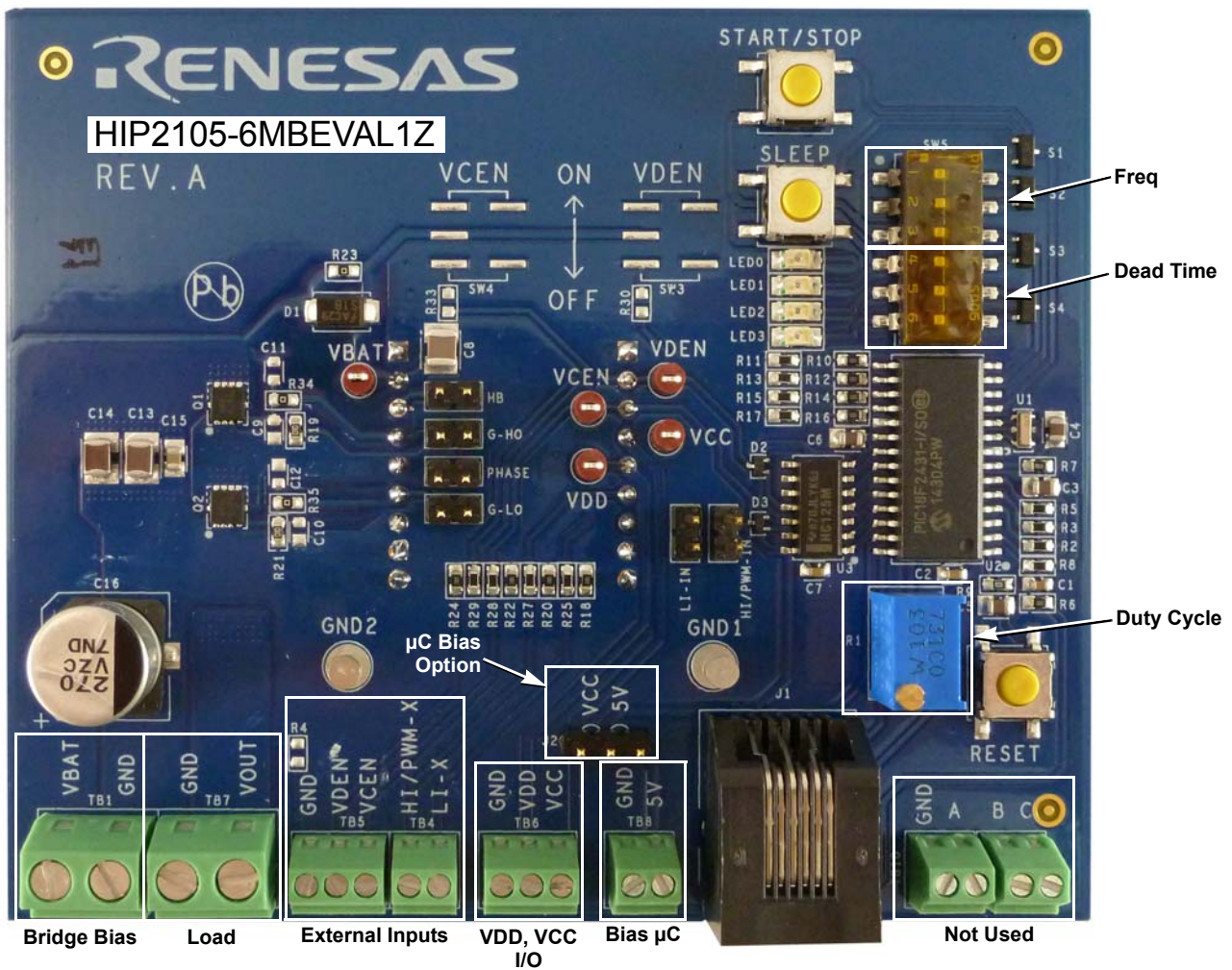

Figure 9. HIP2105-6MBEVAL1Z Top View

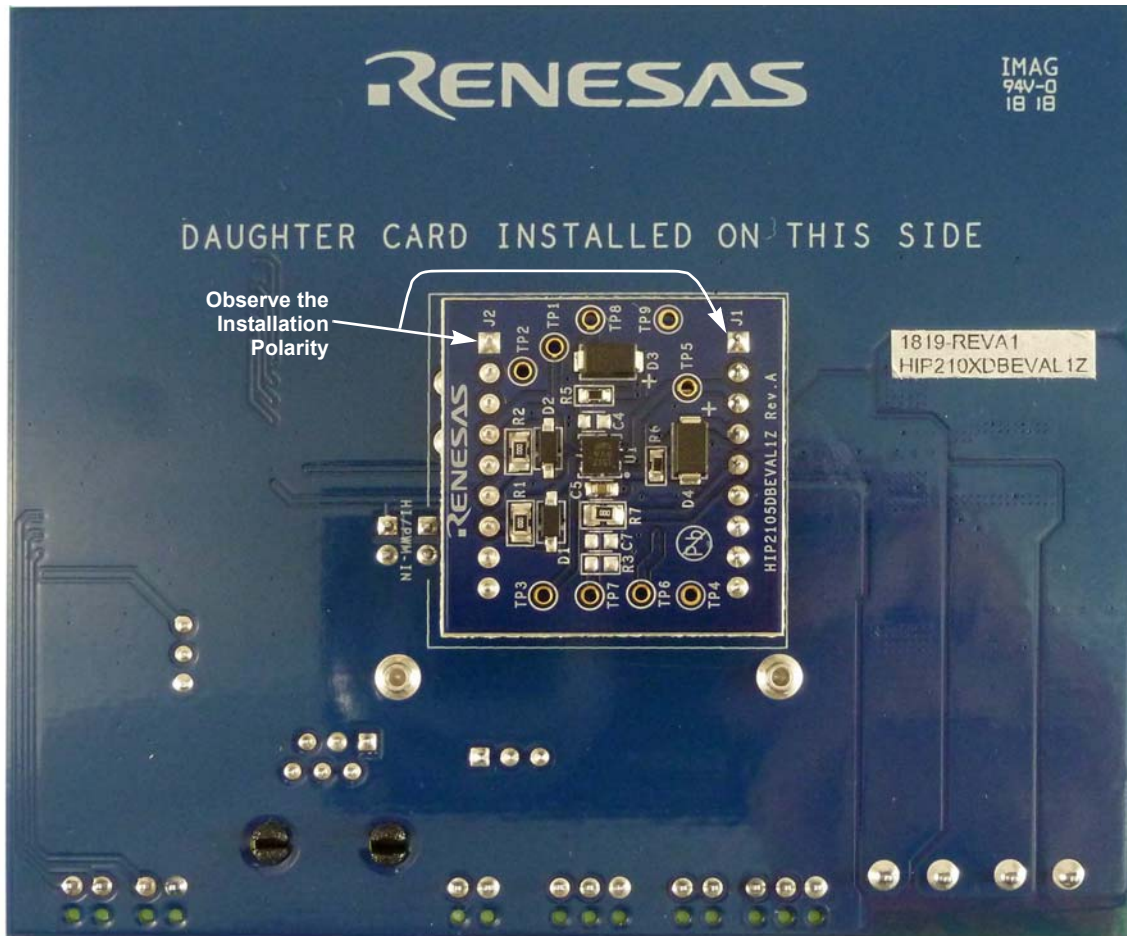

Figure 10. HIP2105-6MBEVAL1Z Bottom View

3.2 Schematics

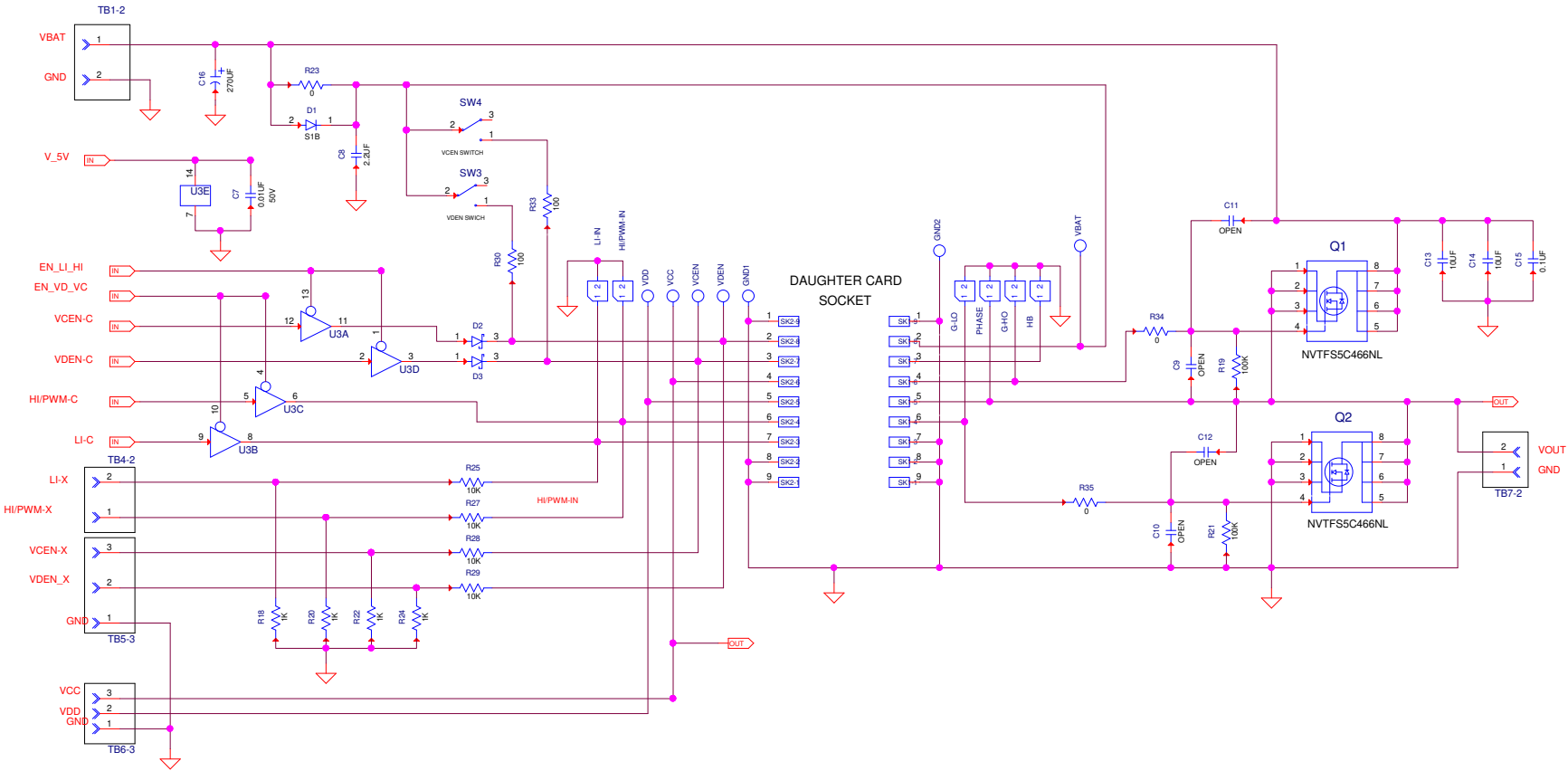
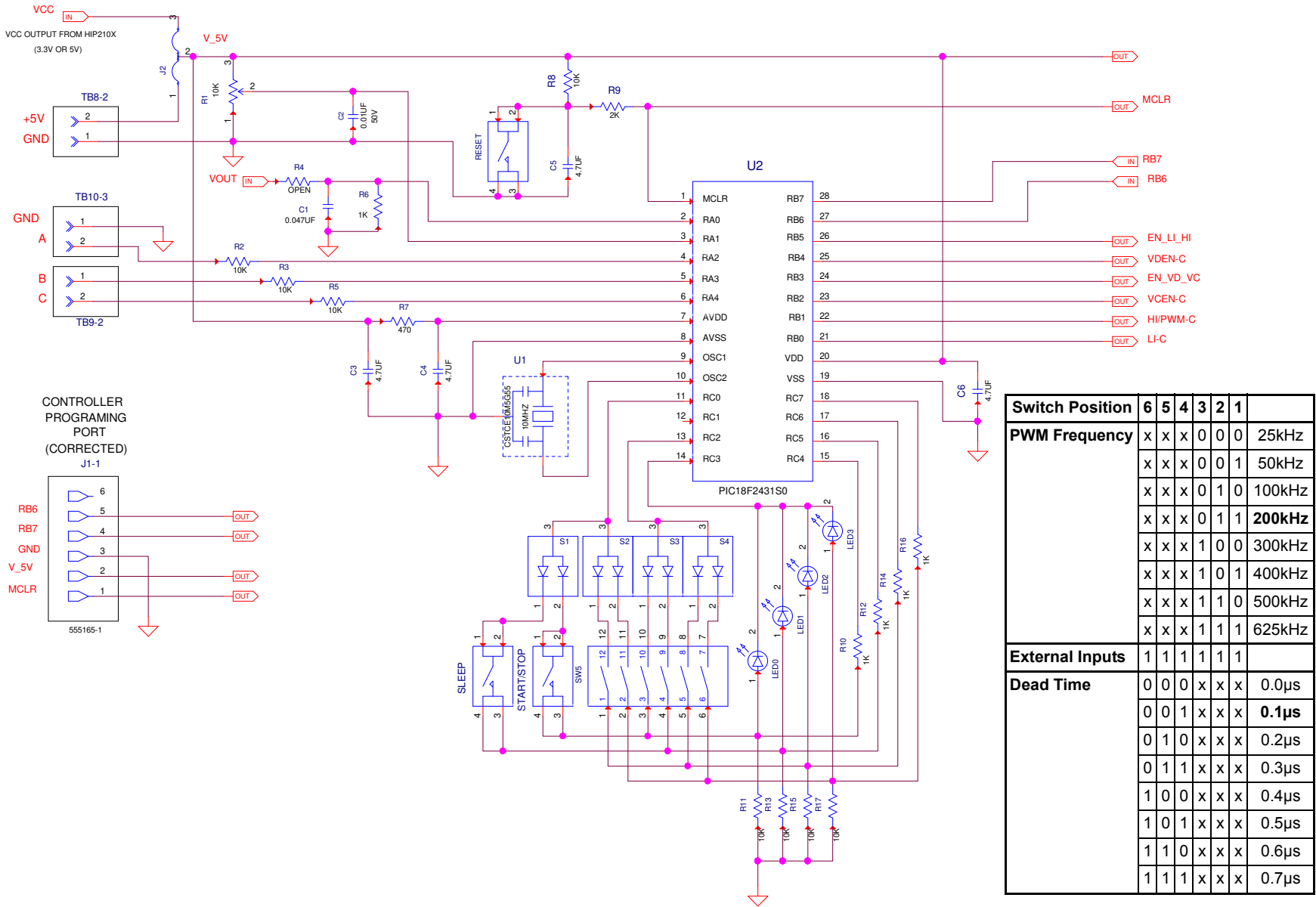

Figure 11. HIP2105-6MBEVAL1Z Bridge and Daughter Card Socket Schematic



Switch Position	6	5	4	3	2	1	
PWM Frequency	x	x	x	0	0	0	25kHz
	x	x	x	0	0	1	50kHz
	x	x	x	0	1	0	100kHz
	x	x	x	0	1	1	200kHz
	x	x	x	1	0	0	300kHz
	x	x	x	1	0	1	400kHz
	x	x	x	1	1	0	500kHz
x	x	x	1	1	1	625kHz	
External Inputs	1	1	1	1	1	1	
Dead Time	0	0	0	x	x	x	0.0µs
	0	0	1	x	x	x	0.1µs
	0	1	0	x	x	x	0.2µs
	0	1	1	x	x	x	0.3µs
	1	0	0	x	x	x	0.4µs
	1	0	1	x	x	x	0.5µs
	1	1	0	x	x	x	0.6µs
	1	1	1	x	x	x	0.7µs

Figure 12. HIP2105-6MBEVAL1Z Controller

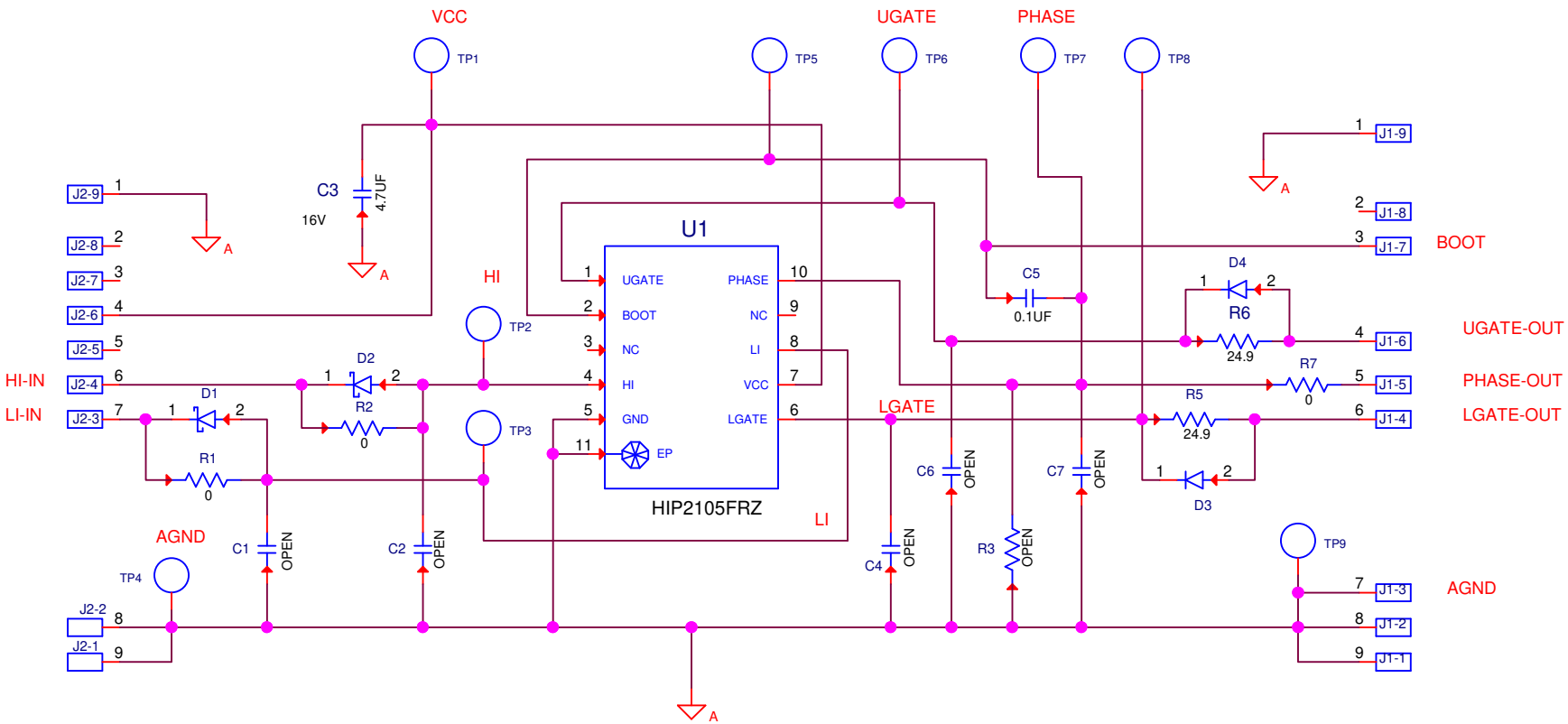

Figure 13. HIP2105DBEVAL1Z Daughter Card Schematic

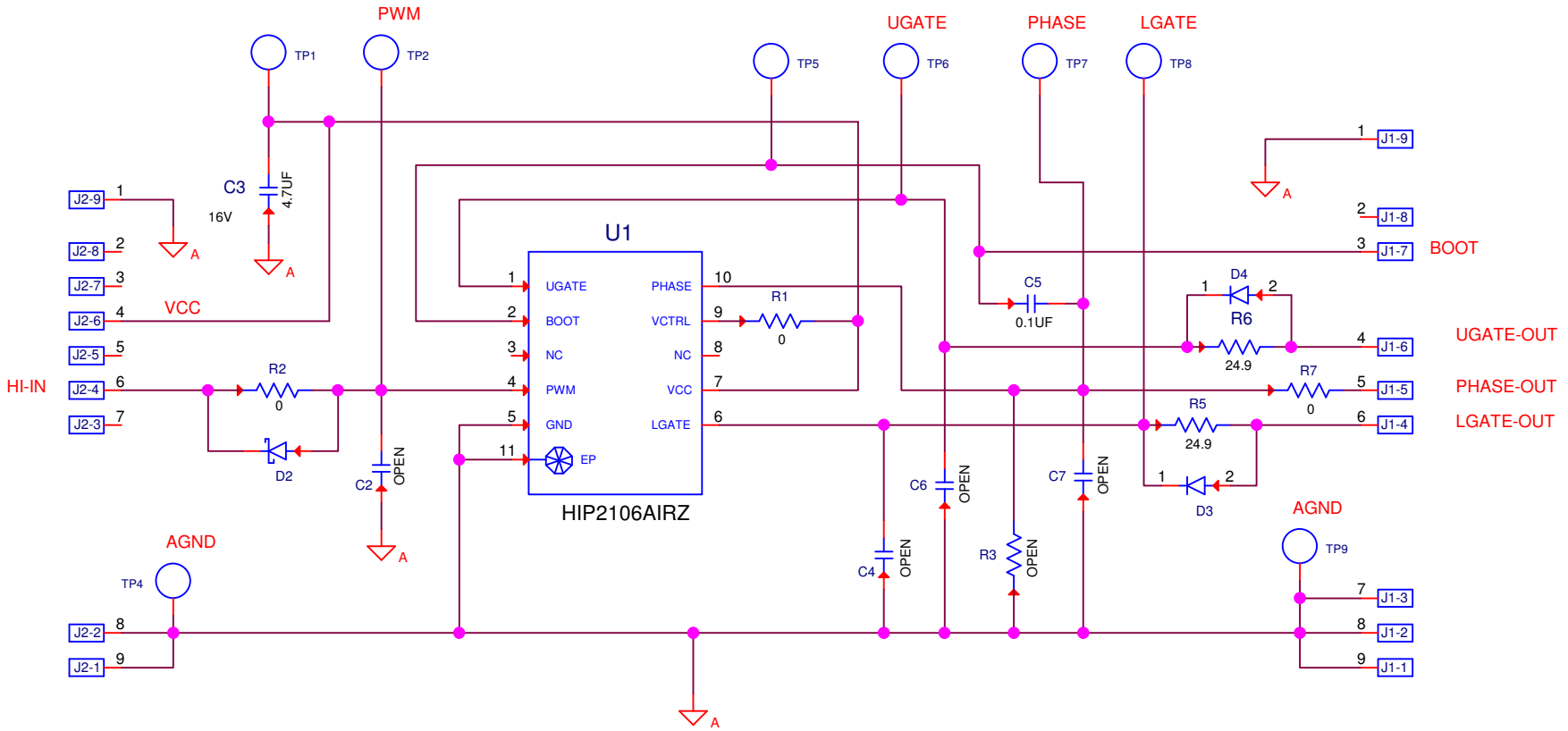

Figure 14. HIP2106ADBEVAL1Z Daughter Card Schematic

3.3 Board Layouts

3.3.1 HIP2105DBEVAL1Z

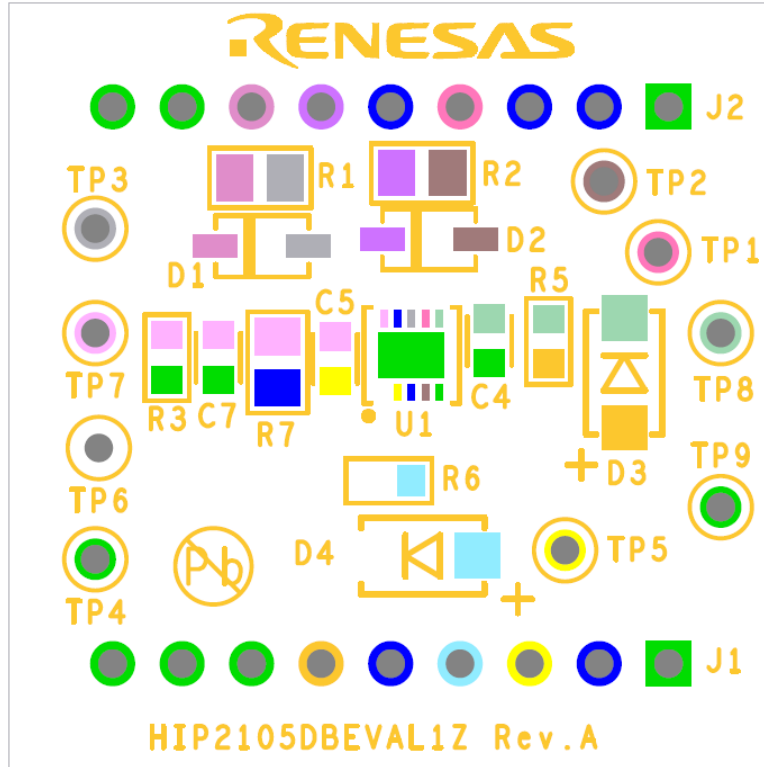

Figure 15. HIP2105DBEVAL1Z Top Silkscreen

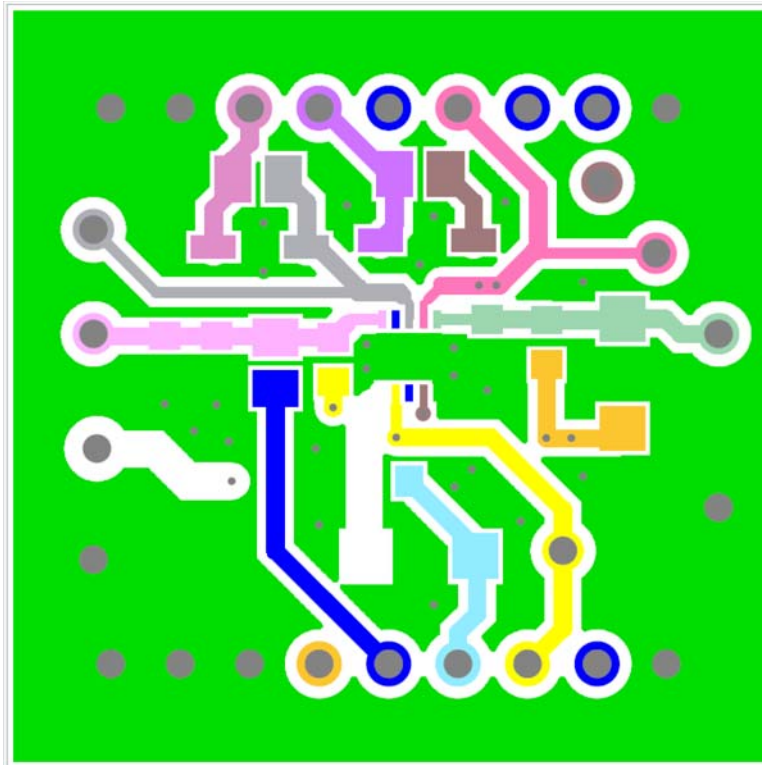

Figure 16. HIP2105DBEVAL1Z Top Layer

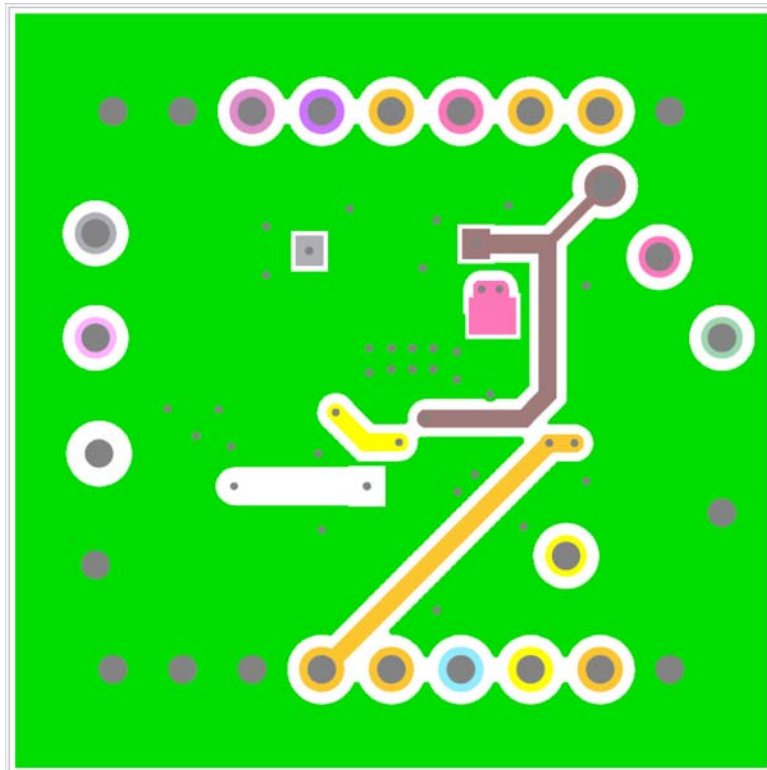

Figure 17. HIP2105DBEVAL1Z Bottom Layer

3.3.2 HIP2106ADBEVAL1Z

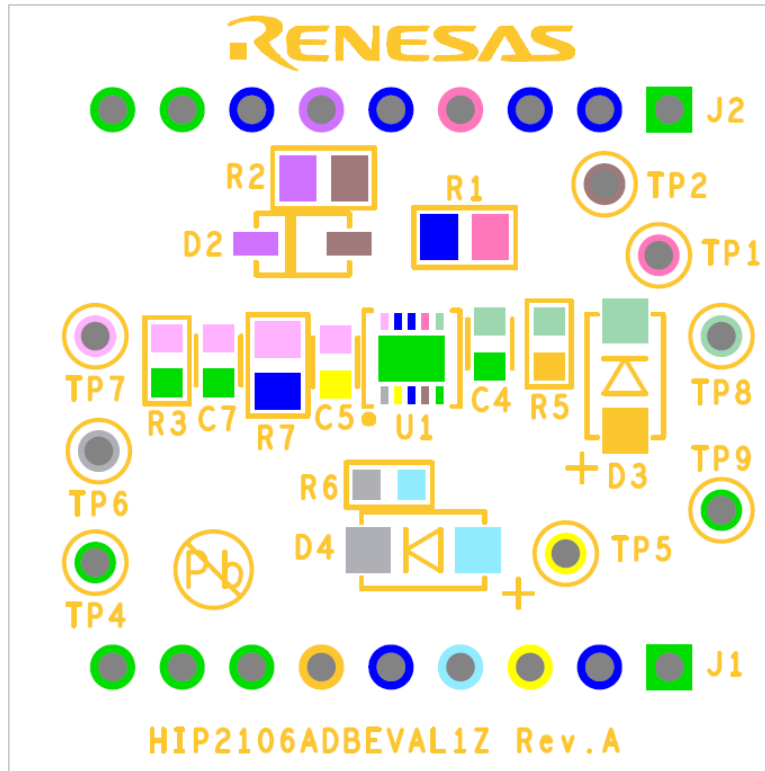

Figure 18. HIP2106ADBEVAL1Z Top Silkscreen

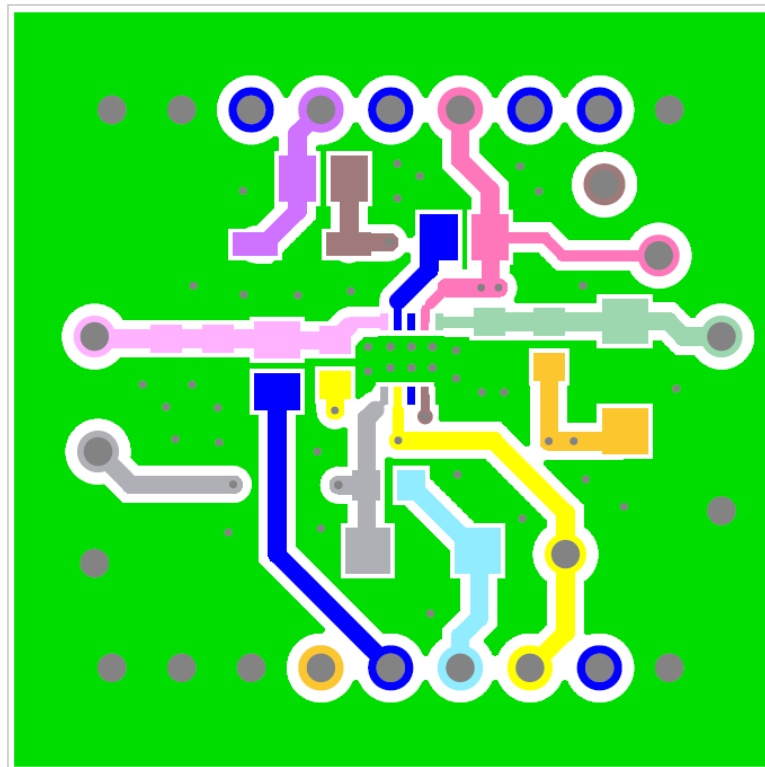

Figure 19. HIP2106ADBEVAL1Z Top Layer

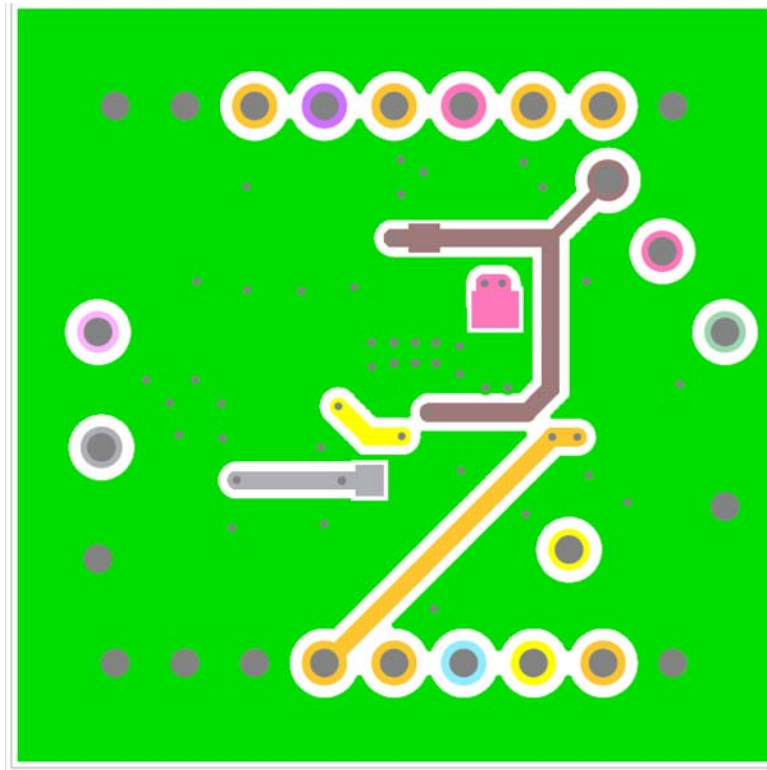

Figure 20. HIP2106ADBEVAL1Z Bottom Layer

3.3.3 HIP2105-6MBEVAL1Z

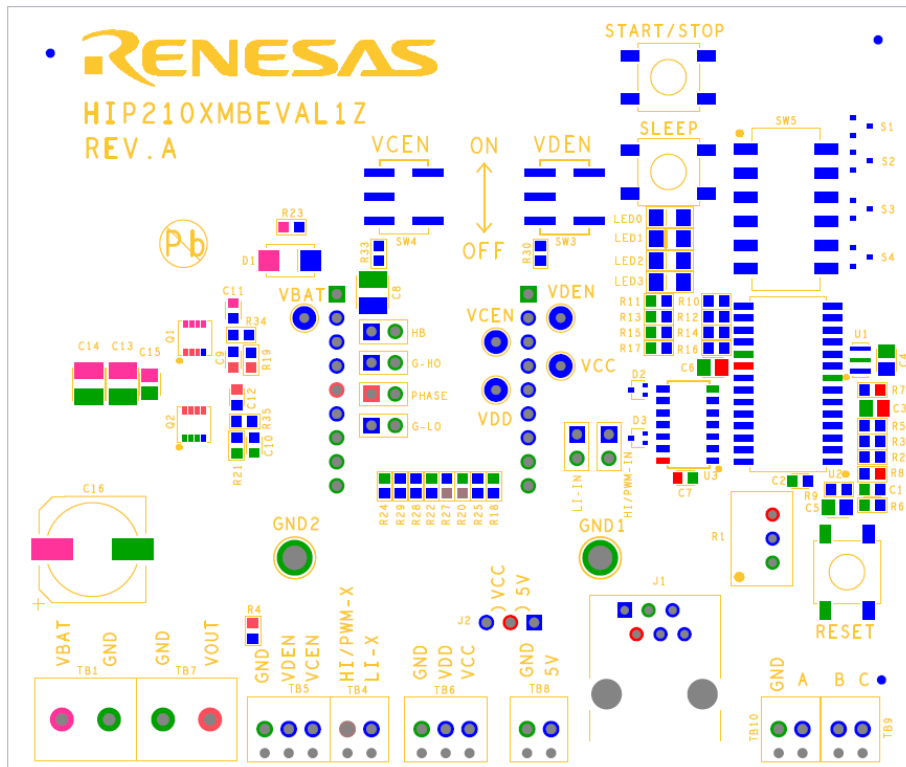

Figure 21. HIP2105-6MBEVAL1Z Top Silkscreen

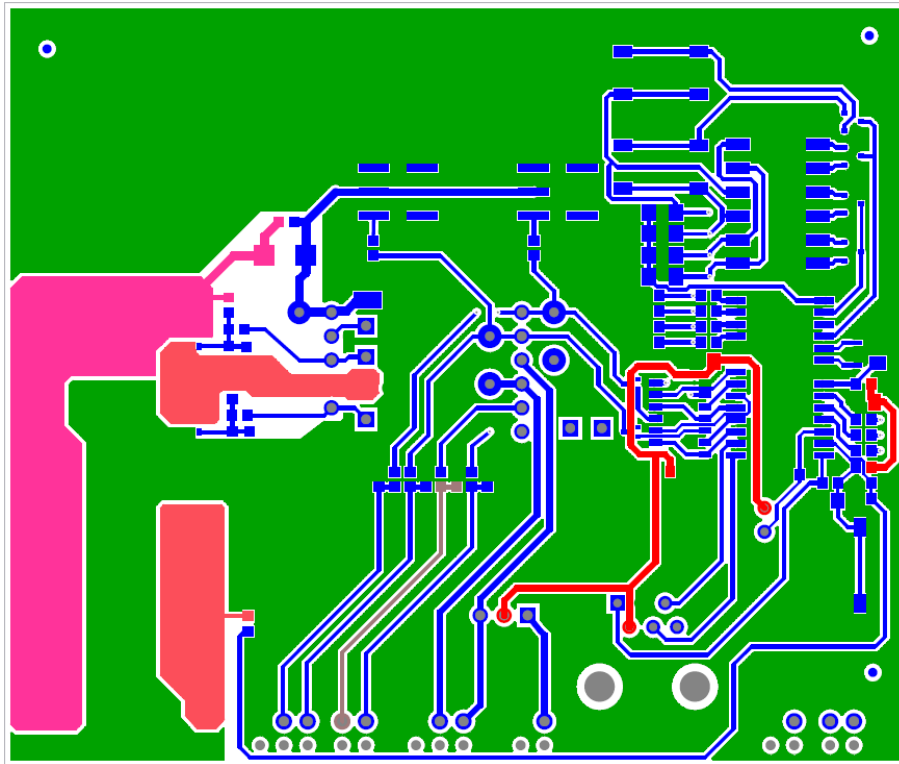

Figure 22. HIP2105-6MBEVAL1Z Top Layer

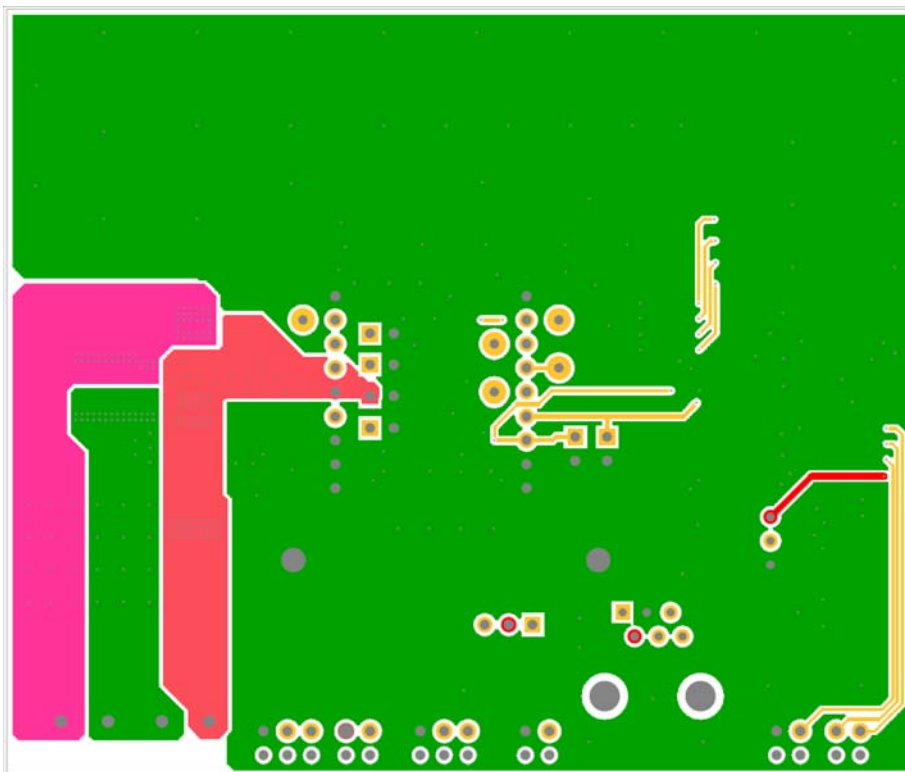

Figure 23. HIP2105-6MBEVAL1Z Bottom Layer

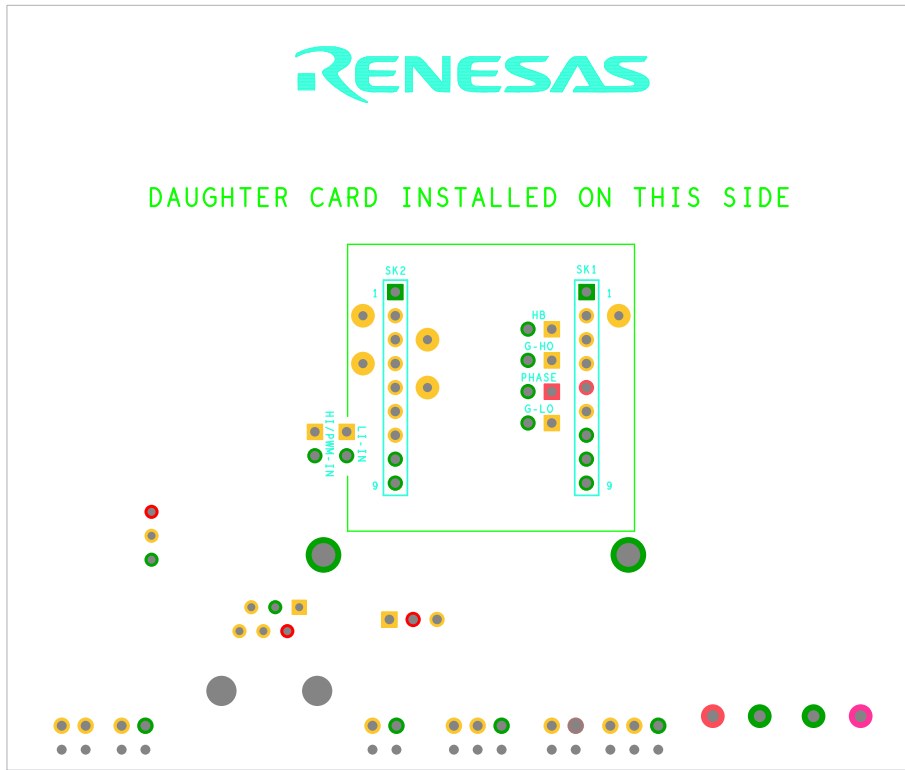

Figure 24. HIP2105-6MBEVAL1Z Bottom Silkscreen

3.4 Bill of Materials

Table 2. HIP2105DBEVAL1Z Bill of Materials

Qty	Reference Designator	Description	Manufacturer	Manufacturer Part Number
1		PWB-PCB, HIP2105DBEVAL1Z, REVA, ROHS	IMAGINEERING INC	HIP2105DBEVAL1ZREVAPCB
1	C3	CAP, SMD, 0805, 4.7µF, 16V, 10%, X7R, ROHS	MURATA	GRM21BR71C475KA73L-T
1	C5	CAP, SMD, 0603, 0.1µF, 25V, 10%, X7R, ROHS	YAGEO	CC0603KRX7R8BB104
0	C1, C2, C4, C6, C7	CAP, SMD, 0603, DNP-PLACE HOLDER, ROHS		
2	J1, J2	CONN-HEADER INTERCONNECT, 1X9, GOLD, LO PROF., ROHS	SAMTEC	BBL-109-G-E
2	D1, D2	DIODE-SCHOTTKY, SMD, 2P, SOD-123, 30V, 200mA, ROHS	VISHAY/GENERAL SEMICONDUCTOR	BAT54W-V-GS08
2	D3, D4	DIODE-RECTIFIER, SMD, 2P, SMA, 50V, 1A, ROHS	DIODES INC.	ES1A-13-F
1	U1	IC-SYNCHRONOUS MOSFET DRIVER, 10P, DFN, 3X3, ROHS	RENESAS ELECTRONICS AMERICA	HIP2105FRZ
2	R5, R6	RES, SMD, 0603, 24.9Ω, 1/10W, 1%, TF, ROHS	PANASONIC	ERJ-3EKF24R9V
0	R3	RES, SMD, 0603, DNP-PLACE HOLDER, ROHS		
3	R1, R2, R7	RES, SMD, 0805, 0Ω, 1/8W, TF, ROHS	YAGEO	RC0805JR-070RL
0	TP1-TP9	DO NOT POPULATE OR PURCHASE		DNP
1	AFFIX TO BACK OF PCB	LABEL-DATE CODE_LINE 1: YRWK/REV#, LINE 2: BOM NAME	RENESAS ELECTRONICS AMERICA	LABEL-DATE CODE

Table 3. HIP2106ADBEVAL1Z Bill of Materials

Qty	Reference Designator	Description	Manufacturer	Manufacturer Part Number
1		PWB-PCB, HIP2106ADBEVAL1Z, REVA, ROHS	IMAGINEERING INC	HIP2106ADBEVAL1ZREVAPCB
1	C3	CAP, SMD, 0805, 4.7µF, 16V, 10%, X7R, ROHS	MURATA	GRM21BR71C475KA73L
1	C5	CAP, SMD, 0603, 0.1µF, 25V, 10%, X7R, ROHS	YAGEO	CC0603KRX7R8BB104
0	C2, C4, C6, C7	CAP, SMD, 0603, DNP-PLACE HOLDER, ROHS		
2	J1, J2	CONN-HEADER INTERCONNECT, 1x9, GOLD, LO PROF., ROHS	SAMTEC	BBL-109-G-E
1	D2	DIODE-SCHOTTKY, SMD, 2P, SOD-123, 30V, 200mA, ROHS	VISHAY/GENERAL SEMICONDUCTOR	BAT54W-V-GS08
2	D3, D4	DIODE-RECTIFIER, SMD, 2P, SMA, 50V, 1A, ROHS	DIODES INC.	ES1A-13-F
1	U1	IC-SYNCHRONOUS MOSFET DRIVER, 10P, DFN, 3X3, ROHS	RENESAS ELECTRONICS AMERICA	HIP2106AIRZ
2	R5, R6	RES, SMD, 0603, 24.9Ω, 1/10W, 1%, TF, ROHS	PANASONIC	ERJ-3EKF24R9V
0	R3	RES, SMD, 0603, DNP-PLACE HOLDER, ROHS		
3	R1, R2, R7	RES, SMD, 0805, 0Ω, 1/8W, TF, ROHS	Yageo	RC0805JR-070RL
0	TP1, TP2, TP4-TP9	DO NOT POPULATE OR PURCHASE		DNP
1	AFFIX TO BACK OF PCB	LABEL-DATE CODE_LINE 1: YRWK/REV#, LINE 2: BOM NAME	RENESAS ELECTRONICS AMERICA	LABEL-DATE CODE

Table 4. HIP2105-6MBEVAL1Z Bill of Materials

Qty	Reference Designator	Description	Manufacturer	Manufacturer Part
1		PWB-PCB, HIP2105-6MBEVAL1Z, REVA, ROHS	IMAGINEERING INC	HIP2105-6MBEVAL1ZREVAPCB
2	C13, C14	CAP, SMD, 1210, 10µF, 50V, 10%, X7S, ROHS	TDK	C3225X7S1H106K
2	C2, C7	CAP, SMD, 0603, .01µF, 50V, 10%, X7R, ROHS	MURATA	GRM39X7R103K050
1	C1	CAP, SMD, 0603, 0.047µF, 25V, 10%, X7R, ROHS	MURATA	GRM188R71E473KA01D
0	C9, C10, C11, C12	CAP, SMD, 0603, DNP-PLACE HOLDER, ROHS		
1	C15	CAP, SMD, 0805, 0.1µF, 50V, 10%, X7R, ROHS	KEMET	C0805C104K5RACTU
4	C3, C4, C5, C6	CAP, SMD, 0805, 4.7µF, 16V, 10%, X7R, ROHS	MURATA	GCJ21BR71C475KA01L
1	C8	CAP, SMD, 1210, 2.2µF, 100V, 10%, X7R, ROHS	MURATA	GRM32ER72A225KA35L
1	C16	CAP-AEC-Q200, SMD, 10.3mm, 270µF, 35V, 20%, 20mOhm, ROHS	PANASONIC	EEH-ZC1V271P
2	GND1, GND2	CONN-TURRET, TERMINAL POST, TH, ROHS	KEYSTONE	1514-2
4	TB4, TB8, TB9, TB10	CONN-TERMINAL BLK, TH, 2P, 6A, 125V, 20-30AWG, 2.54mm, ROHS	PHOENIX CONTACT	1725656
2	TB5, TB6	CONN-TERMINAL BLK, TH, 3POS, 2.54mm, 20-30AWG, ROHS	PHOENIX CONTACT	1725669
2	TB1, TB7	CONN-TERMINAL BLK, TH, 2POS, 5mmPITCH, 14-30AWG, ROHS	PHOENIX CONTACT	1729018
5	VCC, VDD, VBAT, VCEN, VDEN	CONN-MINI TEST PT, VERTICAL, RED, ROHS	KEYSTONE	5000
6	HB, G-HO, G-LO, LI-IN, PHASE, HI/PWM-IN	CONN-HEADER, 1x2, BRKAWY 1x36, 2.54mm, ROHS	BERG/FCI	68000-236HLF
1	J2	CONN-HEADER, 1x3, BREAKAWY 1x36, 2.54mm, ROHS	BERG/FCI	68000-236HLF
2	SK1, SK2	CONN-HDR, 1x9, BRKAWY 1x36, 2.54mm, ST, ROHS	BERG/FCI	68000-236
2	D2, D3	DIODE-SCHOTTKY, SMD, SOT-523, 70V, 70mA, ROHS	MICRO COMMERCIAL CO.	BAS70T-TP
4	S1, S2, S3, S4	DIODE-DUAL, COMMON ANODE, SMD, SOT-23, 85V, 200mA, ROHS	FAIRCHILD	BAW56
1	D1	DIODE-RECTIFIER, SMD, 2P, SMA, 100V, 1A, ROHS	FAIRCHILD	S1B
4	LED0, LED1, LED2, LED3	LED, SMD, 1206, RED, 30mA, 60mW, 17mcd, ROHS	DIALIGHT	597-3111-407F
1	U3	IC-TRI-STATE QUAD BUFFER, 14P, SOIC, ROHS	TEXAS INSTRUMENTS	CD74HC125M
1	U2	IC-PIC MCU FLASH, 16KB, 28P, SOIC, ROHS	MICROCHIP TECHNOLOGY	PIC18F2431-I/SO
2	Q1, Q2	TRANSISTOR-MOS, N-CHANNEL, 40V, 51A, SMD, 8P, WDFN, ROHS	ON SEMICONDUCTOR	NVTF5C466NLTAG
1	R1	POT-TRIM, TH, 3P, 10k, 1/2W, 10%, 3/8SQ, 25TURN, TOPADJ, ROHS	BOURNS	3299W-1-103LF
3	R23, R34, R35	RES, SMD, 0603, 0Ω, 1/10W, TF, ROHS	VENKEL	CR0603-10W-000T
9	R6, R10, R12, R14, R16, R18, R20, R22, R24	RES, SMD, 0603, 1k, 1/10W, 1%, TF, ROHS	PANASONIC	ERJ-3EKF1001V

Table 4. HIP2105-6MBEVAL1Z Bill of Materials (Continued)

Qty	Reference Designator	Description	Manufacturer	Manufacturer Part
12	R2, R3, R5, R8, R11, R13, R15, R17, R25, R27, R28, R29	RES, SMD, 0603, 10k, 1/10W, 1%, TF, ROHS	VENKEL	CR0603-10W-1002FT
2	R19, R21	RES, SMD, 0603, 100k, 1/10W, 1%, TF, ROHS	VENKEL	CR0603-10W-1003FT
1	R9	RES, SMD, 0603, 2k, 1/10W, 1%, TF, ROHS	KOA	RK73H1JTDD2001F
1	R7	RES, SMD, 0603, 470Ω, 1/10W, 1%, TF, ROHS	ROHM	MCR03EZPFX4700
0	R4, R30, R33	RES, SMD, 0603, DNP-PLACE HOLDER, ROHS		
3	RESET, SLEEP, START/STOP	SWITCH-TACTILE, PUSH, SMD, 4.3x9, SPST, ROHS	OMRON	B3S-1002
1	SW5	SWITCH-DIP, SMD, 6POS, TOP SLIDE, SPST, SEALED, ROHS	ITT INDUSTRIES/C&K DIVISION	SD06H0SB
4	Bottom four corners	BUMPONS, 0.44inW x 0.20inH, DOMETOP, , BLACK	3M	SJ-5003SPBL
1	Place assy in bag	BAG, STATIC, 6x8, ZIPLOC, ROHS	ULINE	S-2262
1	J1	CONN-PC PHONEJACK, TH, R/A, 6POS, GOLD, ROHS	AMP/TYCO	5555165-1
1	U1	OSC-RESONATOR, SMD, 3.2x1.3, 10MHz, 0.5%, 33pF, ROHS	MURATA	CSTCE10M0G55-R0
0	SW3, SW4 (GT11MSCBE-T)	DO NOT POPULATE OR PURCHASE		
1	AFFIX TO BACK OF PCB	LABEL-DATE CODE_LINE 1: YRWK/REV#, LINE 2: BOM NAME	RENESAS ELECTRONICS AMERICA	LABEL-DATE CODE

4. Revision History

Rev.	Date	Description
1.00	Jul 31, 2018	Updated part number from: HIP2105IRZ to: HIP2105FRZ, in Figure 13 and in Table 2 - HIP2105DBEVAL1Z Bill of Materials.
0.00	Jun 5, 2018	Initial release

Notice

1. Descriptions of circuits, software and other related information in this document are provided only to illustrate the operation of semiconductor products and application examples. You are fully responsible for the incorporation or any other use of the circuits, software, and information in the design of your product or system. Renesas Electronics disclaims any and all liability for any losses and damages incurred by you or third parties arising from the use of these circuits, software, or information.
2. Renesas Electronics hereby expressly disclaims any warranties against and liability for infringement or any other claims involving patents, copyrights, or other intellectual property rights of third parties, by or arising from the use of Renesas Electronics products or technical information described in this document, including but not limited to, the product data, drawings, charts, programs, algorithms, and application examples.
3. No license, express, implied or otherwise, is granted hereby under any patents, copyrights or other intellectual property rights of Renesas Electronics or others.
4. You shall not alter, modify, copy, or reverse engineer any Renesas Electronics product, whether in whole or in part. Renesas Electronics disclaims any and all liability for any losses or damages incurred by you or third parties arising from such alteration, modification, copying or reverse engineering.
5. Renesas Electronics products are classified according to the following two quality grades: "Standard" and "High Quality". The intended applications for each Renesas Electronics product depends on the product's quality grade, as indicated below.
"Standard": Computers; office equipment; communications equipment; test and measurement equipment; audio and visual equipment; home electronic appliances; machine tools; personal electronic equipment; industrial robots; etc.
"High Quality": Transportation equipment (automobiles, trains, ships, etc.); traffic control (traffic lights); large-scale communication equipment; key financial terminal systems; safety control equipment; etc.
Unless expressly designated as a high reliability product or a product for harsh environments in a Renesas Electronics data sheet or other Renesas Electronics document, Renesas Electronics products are not intended or authorized for use in products or systems that may pose a direct threat to human life or bodily injury (artificial life support devices or systems; surgical implantations; etc.), or may cause serious property damage (space system; undersea repeaters; nuclear power control systems; aircraft control systems; key plant systems; military equipment; etc.). Renesas Electronics disclaims any and all liability for any damages or losses incurred by you or any third parties arising from the use of any Renesas Electronics product that is inconsistent with any Renesas Electronics data sheet, user's manual or other Renesas Electronics document.
6. When using Renesas Electronics products, refer to the latest product information (data sheets, user's manuals, application notes, "General Notes for Handling and Using Semiconductor Devices" in the reliability handbook, etc.), and ensure that usage conditions are within the ranges specified by Renesas Electronics with respect to maximum ratings, operating power supply voltage range, heat dissipation characteristics, installation, etc. Renesas Electronics disclaims any and all liability for any malfunctions, failure or accident arising out of the use of Renesas Electronics products outside of such specified ranges.
7. Although Renesas Electronics endeavors to improve the quality and reliability of Renesas Electronics products, semiconductor products have specific characteristics, such as the occurrence of failure at a certain rate and malfunctions under certain use conditions. Unless designated as a high reliability product or a product for harsh environments in a Renesas Electronics data sheet or other Renesas Electronics document, Renesas Electronics products are not subject to radiation resistance design. You are responsible for implementing safety measures to guard against the possibility of bodily injury, injury or damage caused by fire, and/or danger to the public in the event of a failure or malfunction of Renesas Electronics products, such as safety design for hardware and software, including but not limited to redundancy, fire control and malfunction prevention, appropriate treatment for aging degradation or any other appropriate measures. Because the evaluation of microcomputer software alone is very difficult and impractical, you are responsible for evaluating the safety of the final products or systems manufactured by you.
8. Please contact a Renesas Electronics sales office for details as to environmental matters such as the environmental compatibility of each Renesas Electronics product. You are responsible for carefully and sufficiently investigating applicable laws and regulations that regulate the inclusion or use of controlled substances, including without limitation, the EU RoHS Directive, and using Renesas Electronics products in compliance with all these applicable laws and regulations. Renesas Electronics disclaims any and all liability for damages or losses occurring as a result of your noncompliance with applicable laws and regulations.
9. Renesas Electronics products and technologies shall not be used for or incorporated into any products or systems whose manufacture, use, or sale is prohibited under any applicable domestic or foreign laws or regulations. You shall comply with any applicable export control laws and regulations promulgated and administered by the governments of any countries asserting jurisdiction over the parties or transactions.
10. It is the responsibility of the buyer or distributor of Renesas Electronics products, or any other party who distributes, disposes of, or otherwise sells or transfers the product to a third party, to notify such third party in advance of the contents and conditions set forth in this document.
11. This document shall not be reprinted, reproduced or duplicated in any form, in whole or in part, without prior written consent of Renesas Electronics.
12. Please contact a Renesas Electronics sales office if you have any questions regarding the information contained in this document or Renesas Electronics products.
(Note 1) "Renesas Electronics" as used in this document means Renesas Electronics Corporation and also includes its directly or indirectly controlled subsidiaries.
(Note 2) "Renesas Electronics product(s)" means any product developed or manufactured by or for Renesas Electronics.

(Rev.4.0-1 November 2017)



SALES OFFICES

Renesas Electronics Corporation

<http://www.renesas.com>

Refer to "<http://www.renesas.com/>" for the latest and detailed information.

Renesas Electronics America Inc.

1001 Murphy Ranch Road, Milpitas, CA 95035, U.S.A.
Tel: +1-408-432-8888, Fax: +1-408-434-5351

Renesas Electronics Canada Limited

9251 Yonge Street, Suite 8309 Richmond Hill, Ontario Canada L4C 9T3
Tel: +1-905-237-2004

Renesas Electronics Europe Limited

Dukes Meadow, Millboard Road, Bourne End, Buckinghamshire, SL8 5FH, U.K
Tel: +44-1628-651-700, Fax: +44-1628-651-804

Renesas Electronics Europe GmbH

Arcadiastrasse 10, 40472 Düsseldorf, Germany
Tel: +49-211-6503-0, Fax: +49-211-6503-1327

Renesas Electronics (China) Co., Ltd.

Room 1709 Quantum Plaza, No.27 ZhichunLu, Haidian District, Beijing, 100191 P. R. China
Tel: +86-10-8235-1155, Fax: +86-10-8235-7679

Renesas Electronics (Shanghai) Co., Ltd.

Unit 301, Tower A, Central Towers, 555 Langao Road, Putuo District, Shanghai, 200333 P. R. China
Tel: +86-21-2226-0888, Fax: +86-21-2226-0999

Renesas Electronics Hong Kong Limited

Unit 1601-1611, 16/F., Tower 2, Grand Century Place, 193 Prince Edward Road West, Mongkok, Kowloon, Hong Kong
Tel: +852-2265-6688, Fax: +852 2886-9022

Renesas Electronics Taiwan Co., Ltd.

13F, No. 363, Fu Shing North Road, Taipei 10543, Taiwan
Tel: +886-2-8175-9600, Fax: +886 2-8175-9670

Renesas Electronics Singapore Pte. Ltd.

80 Bendemeer Road, Unit #06-02 Hyflux Innovation Centre, Singapore 339949
Tel: +65-6213-0200, Fax: +65-6213-0300

Renesas Electronics Malaysia Sdn.Bhd.

Unit 1207, Block B, Menara Amcorp, Amcorp Trade Centre, No. 18, Jln Persiaran Barat, 46050 Petaling Jaya, Selangor Darul Ehsan, Malaysia
Tel: +60-3-7955-9390, Fax: +60-3-7955-9510

Renesas Electronics India Pvt. Ltd.

No.777C, 100 Feet Road, HAL 2nd Stage, Indiranagar, Bangalore 560 038, India
Tel: +91-80-67208700, Fax: +91-80-67208777

Renesas Electronics Korea Co., Ltd.

17F, KAMCO Yangjae Tower, 262, Gangnam-daero, Gangnam-gu, Seoul, 06265 Korea
Tel: +82-2-558-3737, Fax: +82-2-558-5338

HIP2105-6MBEVAL1Z

RENESAS