

## Description

The ISL6294AEVAL1Z is an evaluation tool for the ISL6294A single-cell Li-ion battery charger. The evaluation tool provides a complete evaluation platform addressing all data sheet specifications and functionality. The jumpers on the board facilitate the programming of the charge current, different charging conditions, and can be used to make other necessary connections, such as current measurement.

The ISL6294A is a fully integrated single-cell Li-ion battery charger. The ISL6294A accepts input voltages ranging from 4.5V up to 28V. Due to the high voltage capability, the components associated with the cradle input circuit on the evaluation board are good for a 28V supply.

The components assembled in the center square constitute a complete charger, indicating the space saving advantage of the typical ISL6294A installation in space-limited applications.

## Ordering Information

PART NUMBER	DESCRIPTION
ISL6294AEVAL1Z	Evaluation Board for ISL6294A

## Pinout

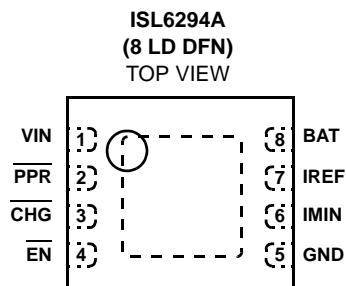

## Features

- A Complete Evaluation Platform for the ISL6294A Charger
- The Center Square Suggesting the Space Saving Advantage of the Typical Components Assembly
- Cradle Input Accepts Voltage up to 28V
- Flexible Power Connectors Each with a Hook and a Solder Pad Providing Variety to Users
- Convenient Jumpers for Programming the Charge Current, Charge Mode, and for Current Measurement
- 3.5x2.5 Square Inches Board Size Handy for Evaluation
- Thermal Vias in the Thermal Pad Similar To Customers' Thermally Enhanced Environment
- On-Board LEDs for Input  $\overline{\text{PPR}}$  and  $\overline{\text{CHG}}$  State Indication

## What is Needed

The following instruments will be needed to perform testing:

- Power supplies:
  - 1) PS1: DC 30V/2A
  - 2) PS2: DC 10V/2A
  - 3) PS3: DC 10V/2A
- DC Electronic load: 20V/2A
- Multimeters
- Function generator
- Oscilloscope
- Cables and wires

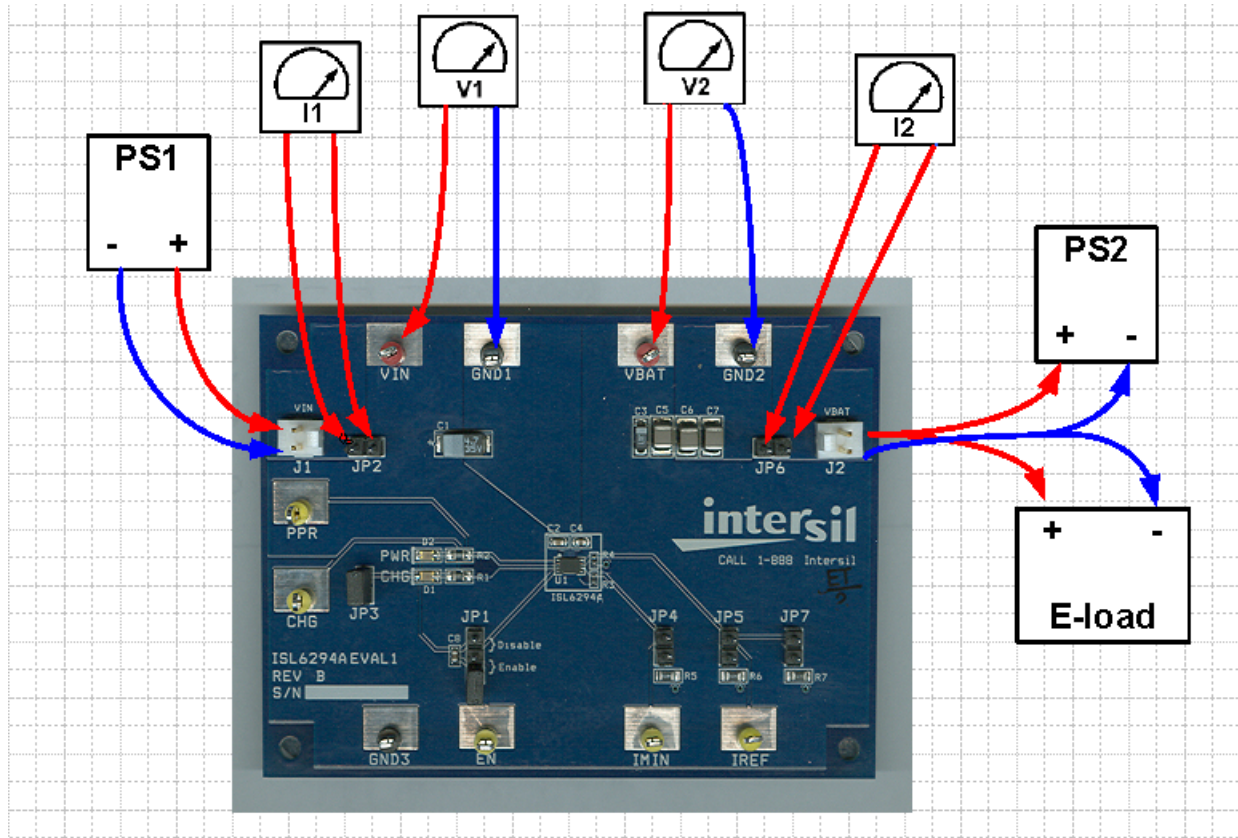

FIGURE 1. CONNECTION OF TEST INSTRUMENTS

## Quick Setup Guide (Refer to Figure 1)

### DO NOT APPLY POWER UNTIL STEP 5

#### For Cradle Input

- Step 1: Connect a 5V supply PS1 to CRDL input (J1, upper +) with the current limit set at 1.3A
- Step 2: Connect a 3.7V supply PS3 to BAT output (J2, upper +) with the current limit set at 1.3A
- Step 3: Connect a current meter to JP6, as shown in Figure 1
- Step 4: Connect the DC electronic load of 1.2A to BAT (J2, upper +)
- Step 5: Insert a jumper shunt on JP2, JP3, JP4 and JP5, all other jumpershunts are not installed
- Step 6: Turn on Power Supplies and DC electronic load; adjust the power supply PS3 such that the voltmeter V2 reads 3.7V
- Step 7: Both the red and the green LEDs should be on, indicating power on and charging condition
- Step 8: The current meter I2 should read about 0.6A as the charging current
- Step 9: Insert a jumper shunt on JP7 and the current meter I2 should read about 1.2A charging current
- Step 10: Remove the jumper shunt on JP3 and apply a 3.3V supply, positive to Pin 1 (at the right) of JP3, negative to GND
- Step 11: Slowly reduce the DC electronic load current until the green LED turns off; the current meter I2 should read about 50mA EOC current

**Description of Jumper Settings**

**JP1** - Connects the  $\overline{EN}$  pin to a pull-up voltage or GND. The pull-up voltage is either the BAT voltage (when a shunt is installed on JP3) or an external 3.3V power source (when the shunt on JP3 is removed and a +3.3V supply is connected to pin 1(at the right) of JP3). If there is no shunt installed on JP1, the  $\overline{EN}$  pin is internally pulled down to logic LOW, which enables the charger. If a shunt is installed across the two jumper pins labeled as “Enable”, the  $\overline{EN}$  pin is driven to logic LOW and the charger is enabled, same as floating. If the shunt is installed across the two jumper pins labeled as “Disable” and the pull-up voltage is above 2V, the  $\overline{EN}$  pin is driven to logic HIGH, which disables the charger.

**JP2** - A shunt installed on JP2 connects the input source from connector J1 to the circuit if input current measurement is not needed. The shunt can be replaced by a current meter if input current measurement is needed, as shown in Figure 1.

**JP3** - Selects the power source for logic pull-up and the LED supply. If a shunt is installed, the BAT voltage is selected as the power source. If the shunt is removed, an external power supply of +3.3V can be connected from Pin 1 (at the right) to GND to provide the pull-up and LED supply power. The purpose is to exclude the extra current through the charger when characterizing small currents, such as EOC and quiescent currents.

**JP4** - Connect a 243k resistor from IMIN pin to GND for 50mA EOC current.

**JP5** - Connect a 20k resistor from IREF to GND for 0.6A charge current.

**JP6** - A shunt installed on JP6 connects the BAT pin to the output connector J2 if output current measurement is not needed. The shunt can be replaced by a current meter if output current measurement is needed as shown in Figure 1.

**JP7** - Parallels an additional 20k resistor to the IREF pin (total RICDL = 10k), the charge current will be increased to 1.2A.

**TABLE 1. JUMPER SETTING SUMMARY**

JUMPER	POSITION	FUNCTION
JP1	Shunt on Disable	Charger disabled
	Shunt on Enable	Charger enabled
	Shunt not installed	Charger enabled
JP2	Shunt installed	Connects input source at J1 to VIN pin
JP3	Shunt installed	Select BAT as the pull-up source
JP4	Shunt installed	Sets EOC current to 50mA
JP5	Shunt installed	Sets charging current to 0.6A, if shunt on JP7 is not installed
JP6	Shunt installed	Connects BAT to J2
JP7	Shunt installed	Sets charging current to 1.2A, if shunt on JP5 is also installed

Board Design

Schematic

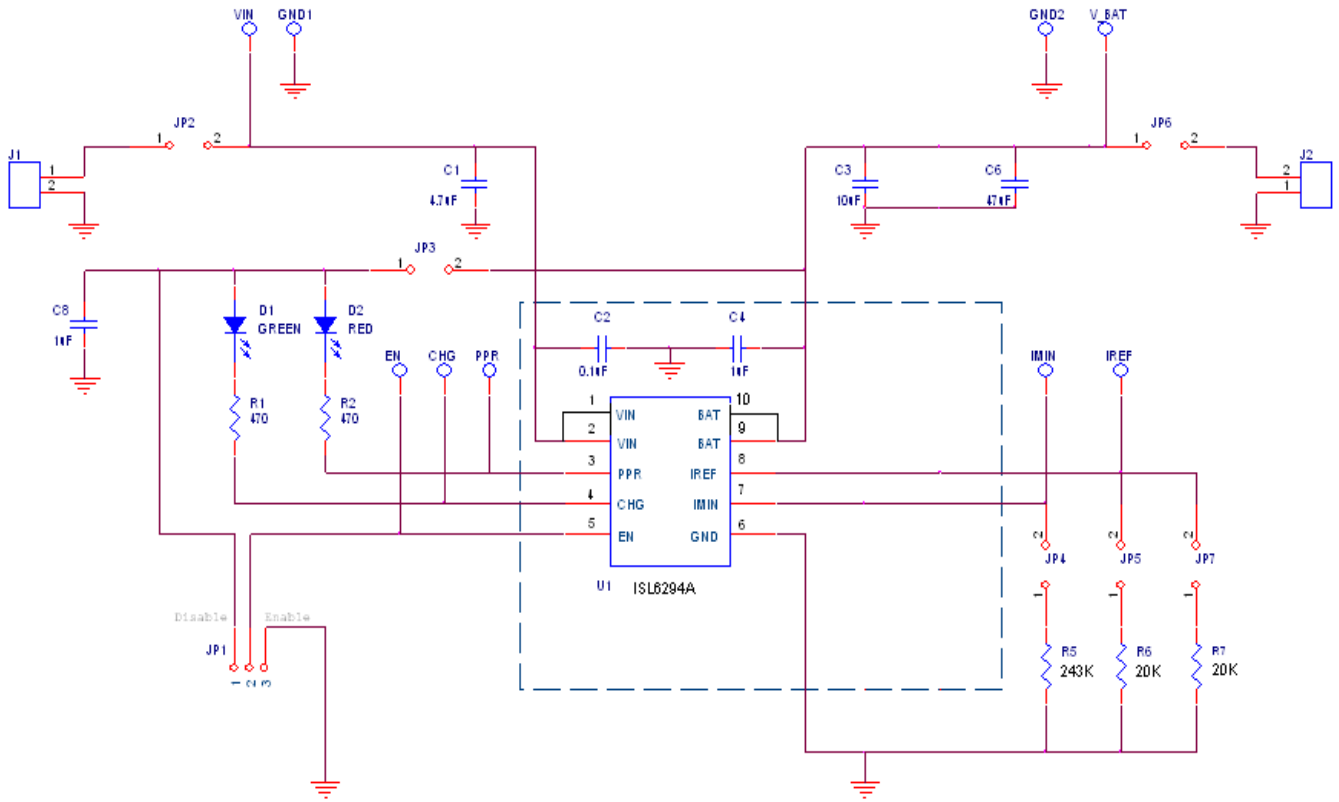

FIGURE 2. SCHEMATIC

## Application Note 1457

**TABLE 2. ISL6294AEVAL1Z BILL OF MATERIALS**

ITEM	QTY	REFERENCE	PART DESCRIPTION	PCB FOOTPRINT	PART NUMBER	VENDOR
1	1	U1	ISL6294A Charger	2x3 DFN	ISL6294A	Intersil
2	2	R1, R2	470Ω, 5%, 1/8W Resistor	0805	ERJ-6GEYJ471V	Panasonic
5	1	R5	243k, 1%, 1/8W Resistor	0805	ERJ-6ENF2433V	Panasonic
6	2	R6, R7	20k, 1% 1/8W Resistor	0805	ERJ-6ENF2002V	Panasonic
7	1	C1	4.7μF, 35V, Tantalum	6032	ECS-T1VC475R	Panasonic
8	1	C2	0.1μF, 50V, X7R Ceramic	0603	C1608X7R1H104K	TDK
9	1	C3	10μF, 6.3V, Tantalum	0603	ECS-T0JY106R	Panasonic
10	2	C4, C8	1.0μF, 6.3V, X5R Ceramic	0603	ECJ-1VB0J105K	Panasonic
11	1	C6	47μF, 6.3V, X5R Ceramic	1210	ECJ-4YB0J476M	Panasonic
12	2	J1, J2	2.54mm Center Header, 2 CKT		22-11-2022	Molex
13	2	CRDL, VBAT	Test point, Red		5010	Keystone
14	5	EN, CHG, PPR, IMIN, ICDL	Test point, Yellow		5014	Keystone
15	4	GND1, GND2, GND3, GND4	Test point, Black		5011	Keystone
16	6	JP2, JP3, JP4, JP5, JP6, JP7	2.54mm header, 2ckt		22-28-4020	Molex
17	1	JP1	2.54mm header, 3ckt		22-28-4030	Molex
18	1	D1	Green LED	0805	SML-LXT0805GW-TR	Lumex Opto
19	1	D2	Red LED	0805	SML-LXT0805IW-TR	Lumex Opto

*Intersil Corporation reserves the right to make changes in circuit design, software and/or specifications at any time without notice. Accordingly, the reader is cautioned to verify that the Application Note or Technical Brief is current before proceeding.*

For information regarding Intersil Corporation and its products, see [www.intersil.com](http://www.intersil.com)