

ISL68300EVAL2Z

User's Manual: Evaluation Board

Core Power Solutions

ISL68300EVAL2Z

Evaluation Board

UG170
Rev.1.00
Jul 13, 2018

1. Overview

The [ISL68300](#) is a PMBus compliant, single-phase digital DC/DC controller with integrated gate drivers for use with N-channel MOSFETs. The ISL68300 implements the Renesas fully digital ChargeMode™ control modulation scheme, allowing both ease of use and industry leading performance. ChargeMode control provides an inherently stable control loop that can respond to load transients in a single switching cycle, significantly decreasing output capacitor requirements.

A dedicated current share bus allows for paralleling up to eight devices in a current share configuration, allowing support for a wide range of load currents.

The ISL68300EVAL2Z evaluation board is a 2.7inx3.0in 6-layer FR4 board with 2oz. copper on all layers. This evaluation board comes with a placeholder for pin-strap resistors to adjust output voltage, switching frequency, and the device PMBus address. More configurations, such as soft-start and fault limits, can be easily programmed or changed using a PMBus compliant serial bus interface.

This evaluation board includes the ZLUSBEVAL3Z (USB to PMBus adapter), which connects the evaluation board to a PC to activate the PMBus communication interface. The PMBus command set is accessed by using the PowerNavigator™ evaluation software from a PC running Microsoft Windows.

1.1 Key Features

- V_{IN} range of 4.5V to 16V, V_{OUT} adjustable from 2.5V to 5.5V
- Programmable V_{OUT} , margining, UV/OV, I_{OUT} limit, soft-start/stop, sequencing, and external synchronization
- Monitor: V_{IN} , V_{OUT} , I_{OUT} , temperature, duty cycle, switching frequency, and faults
- ChargeMode control tunable with PMBus
- On-board load step circuit
- Mechanical switch for enable and power-good LED indicator

1.2 Specifications

This board is configured for the following operating conditions by default:

- $V_{IN} = 7V$ to 16V
- $V_{OUT} = 3.3V$
- $I_{MAX} = 20A$
- $f_{SW} = 500kHz$
- Peak efficiency: >94% at 50% load
- On/off delay = 5ms, on/off ramp time = 5ms

1.3 Ordering Information

Part Number	Description
ISL68300EVAL2Z	ISL68300 board (EVB, ZLUSBEVAL3Z Adapter, USB Cable)

1.4 Related Literature

For a full list of related documents, visit our website

- [ISL68300](#) product page

1.5 Recommended Equipment

- DC power supply with minimum 15V/25A sourcing capacity
- Electronic load capable of sinking current up to 33A
- Digital Multimeters (DMMs)
- Oscilloscope with higher than 100MHz bandwidth

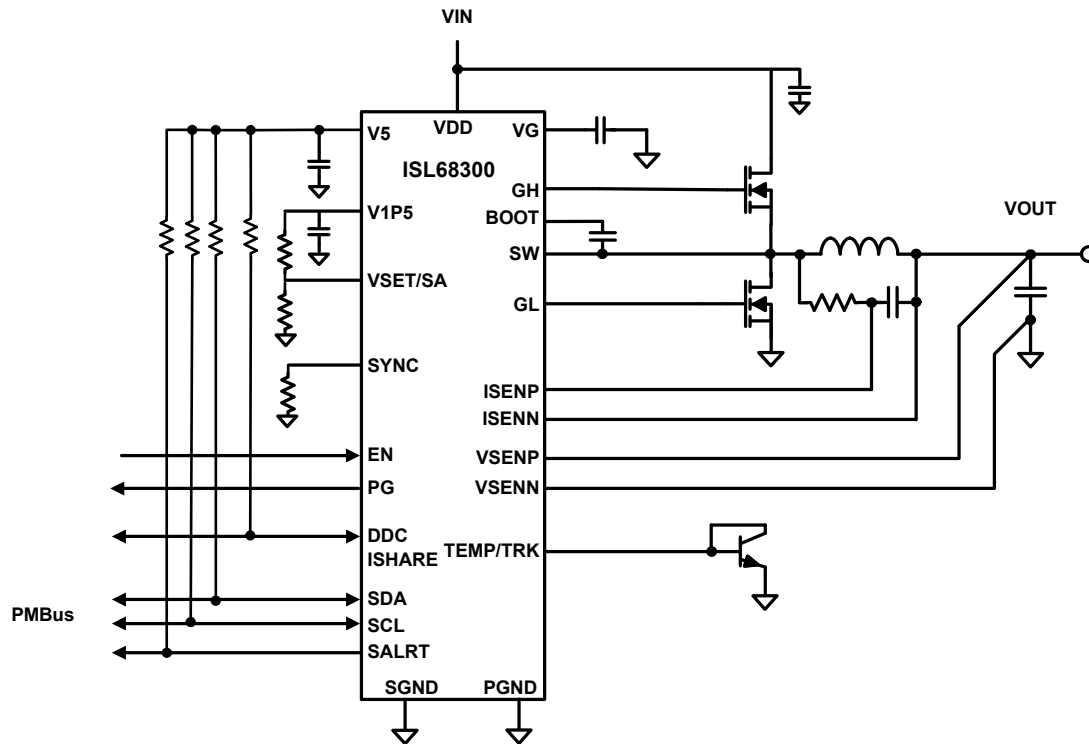

Figure 1. ISL68300EVAL2Z Block Diagram

2. Functional Description

The ISL68300EVAL2Z provides all circuitry required to evaluate the features of the ISL68300. A majority of the features of the ISL68300, such as compensation-free ChargeMode control, soft-start delay and ramp times, supply sequencing, and voltage margining are available on this evaluation board. For sequencing evaluation, the board can be connected to any Renesas digital module evaluation board that supports the Digital-DC™ (DDC) bus.

[Figures 2](#) and [3](#) show the ISL68300EVAL2Z evaluation board.

2.1 Operating Range

By default, the ISL68300EVAL2Z is configured to operate at $V_{OUT} = 3.3V$, $f_{SW} = 500kHz$, and V_{IN} ranges from 7V to 16V. The board can also support a wider operating range to meet the requirements of specific applications. The V_{OUT} can be adjusted from 2.5V to 5.5V and the switching frequency can also be tuned.

If using external synchronization, connect the SYNC test point to the external clock. Note that the external clock signal should be valid before the ISL68300 is enabled.

2.2 PMBus Operation

The ISL68300 uses the PMBus protocol. The PMBus functionality can be controlled using the ZLUSBEVAL3Z dongle from a PC running the PowerNavigator evaluation software.

Install the PowerNavigator from the Renesas [website](#).

For board operation, connect the included ZLUSBEVAL3Z dongle to the 6-pin male connector, J3, labeled “DONGLE”. Connect the desired load and an appropriate power supply to the input and connect the included USB cable to the PC running PowerNavigator. Set the ENABLE switch, SW2, to “OFF” before turning on the power.

PowerNavigator allows modification of all ISL68300 PMBus parameters. The ISL68300 device on the board has been preconfigured as described in this document, but the user can modify the operating parameters through the evaluation software or by loading a predefined set-up from a configuration file. A sample [“Configuration File” on page 18](#) is provided and can be copied to a text editor to make desired changes.

The ENABLE switch, SW3, can then be moved to “ON” and the ISL68300EVAL2Z board can be tested. Alternately, the PMBus ON_OFF_CONFIG and OPERATION commands can be used from PowerNavigator.

2.3 Quick Start Guide

2.3.1 Pin-Strap Option

The ISL68300EVAL2Z can be configured in Pin-Strap mode with standard 1% 0402 resistors. The PMBus interface is not required to evaluate ISL68300 in Pin-Strap mode. Output voltage (V_{OUT}), switching frequency (f_{SW}), and the device PMBus address can be adjusted by changing the pin-strap resistors at the VSET/SA and SYNC pins. By default, the evaluation board is programmed to regulate at $V_{OUT} = 3.3V$, $f_{SW} = 500kHz$, and PMBus address = 61h. Complete the following steps to evaluate the ISL68300 in Pin-Strap mode:

- (1) Set the ENABLE switch to “OFF”.
- (2) Connect a load to the VOUT lug connectors.
- (3) Connect a power supply to the VIN connectors. Make sure the power supply is not enabled when making the connection.
- (4) Turn the power supply on.
- (5) Set the ENABLE switch to “ON”.
- (6) To change V_{OUT} , disconnect the board from the setup and populate with 1% standard 0402 resistors at R_3 and R_5 . Refer to the “Output Voltage and SMBus Address Selection” table in the [ISL68300](#) datasheet for recommended values. By default, VOUT_MAX is set to 115% of V_{OUT} by the pin-strap resistor.
- (7) To change the switching frequency, disconnect the board from the setup and populate with a 1% standard 0402 resistor at R_{35} . Refer to the “Switching Frequency” table in the [ISL68300](#) datasheet for recommended values.

2.3.2 PMBus Option

The ISL68300EVAL2Z can be evaluated for all features using the provided ZLUSBEVAL3Z dongle and PowerNavigator. Complete the following steps to evaluate ISL68300 with the PMBus option.

- (1) Install PowerNavigator.
- (2) Set the ENABLE switch to “OFF”.
- (3) Connect the load to the VOUT lug connectors.
- (4) Connect the power supply to the VIN connectors. Make sure the power supply is not enabled when making the connection.
- (5) Turn the power supply on.
- (6) Connect the ZLUSBEVAL3Z dongle (USB to PMBus adapter) to the ISL68300EVAL2Z board using the 6-pin male connector, J3, labeled “DONGLE”.
- (7) Connect the supplied USB cable from the computer through the USB to the ZLUSBEVAL3Z dongle.
- (8) Launch PowerNavigator.
- (9) Set the ENABLE switch to “ON”.
- (10) Monitor and configure the ISL68300EVAL2Z board using the PMBus commands in PowerNavigator. PowerNavigator tutorial videos are available on the Renesas [website](#).

To sequence using the Digital-DC Bus (DDC), or to evaluate multiple Renesas digital power products using a single ZLUSBEVAL3Z dongle, the ISL68300EVAL2Z can be daisy chained with other digital power evaluation boards. The PMBus address can be changed by placing 1% standard 0402 resistors at R_3 and R_5 . Refer to the “Output Voltage and SMBus Address Selection” table in the [ISL68300](#) datasheet for recommended values.

3. PCB Layout Guidelines

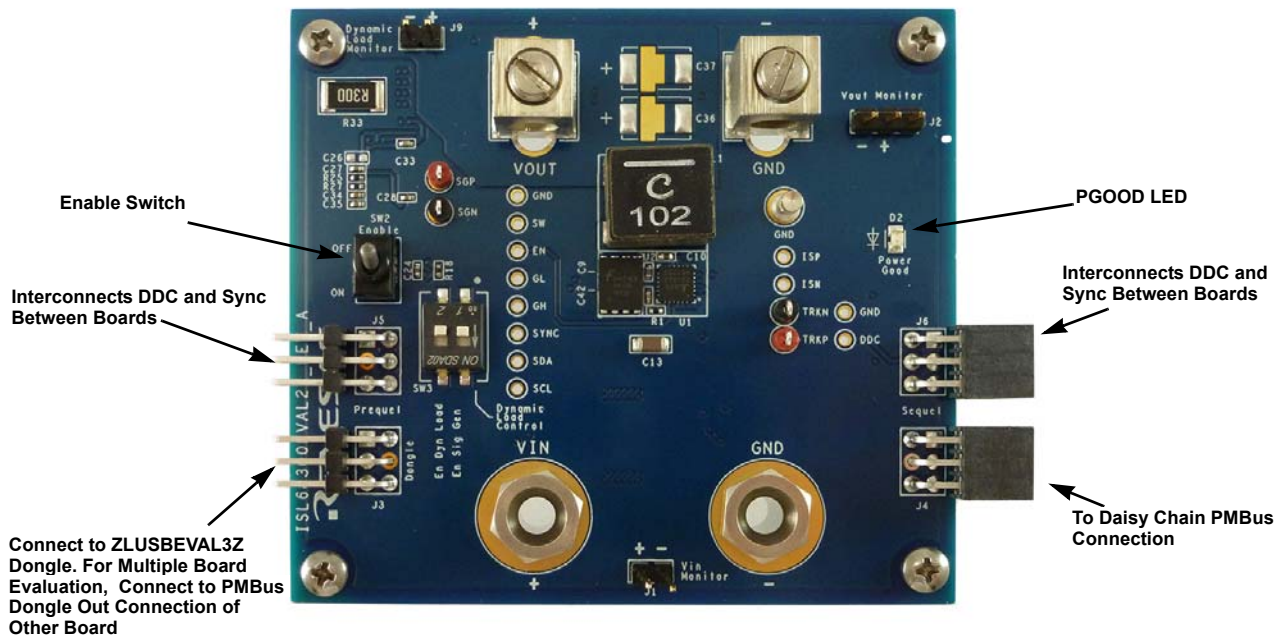

Figure 2. ISL68300EVAL2Z Evaluation Board (Top Side)

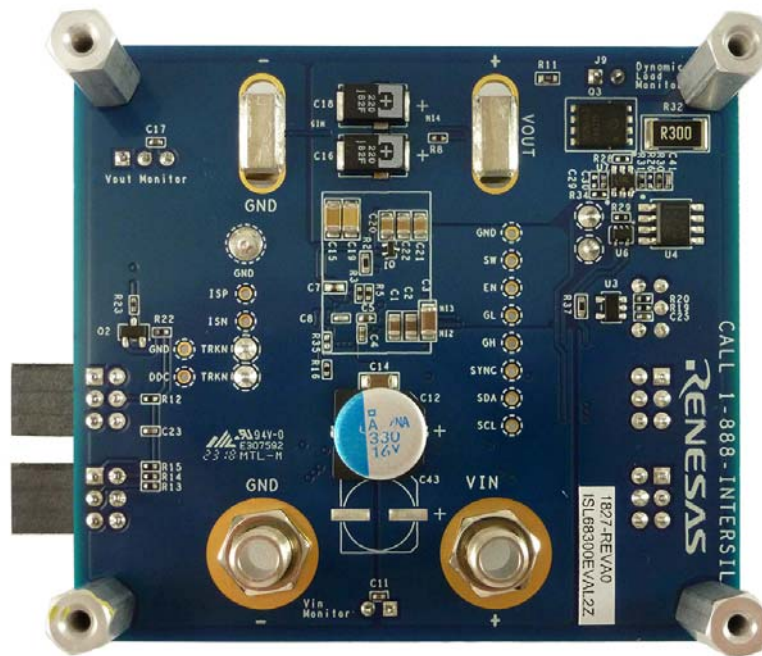

Figure 3. ISL68300EVAL2Z Evaluation Board (Bottom Side)

3.1 ISL68300EVAL2Z Board Schematic

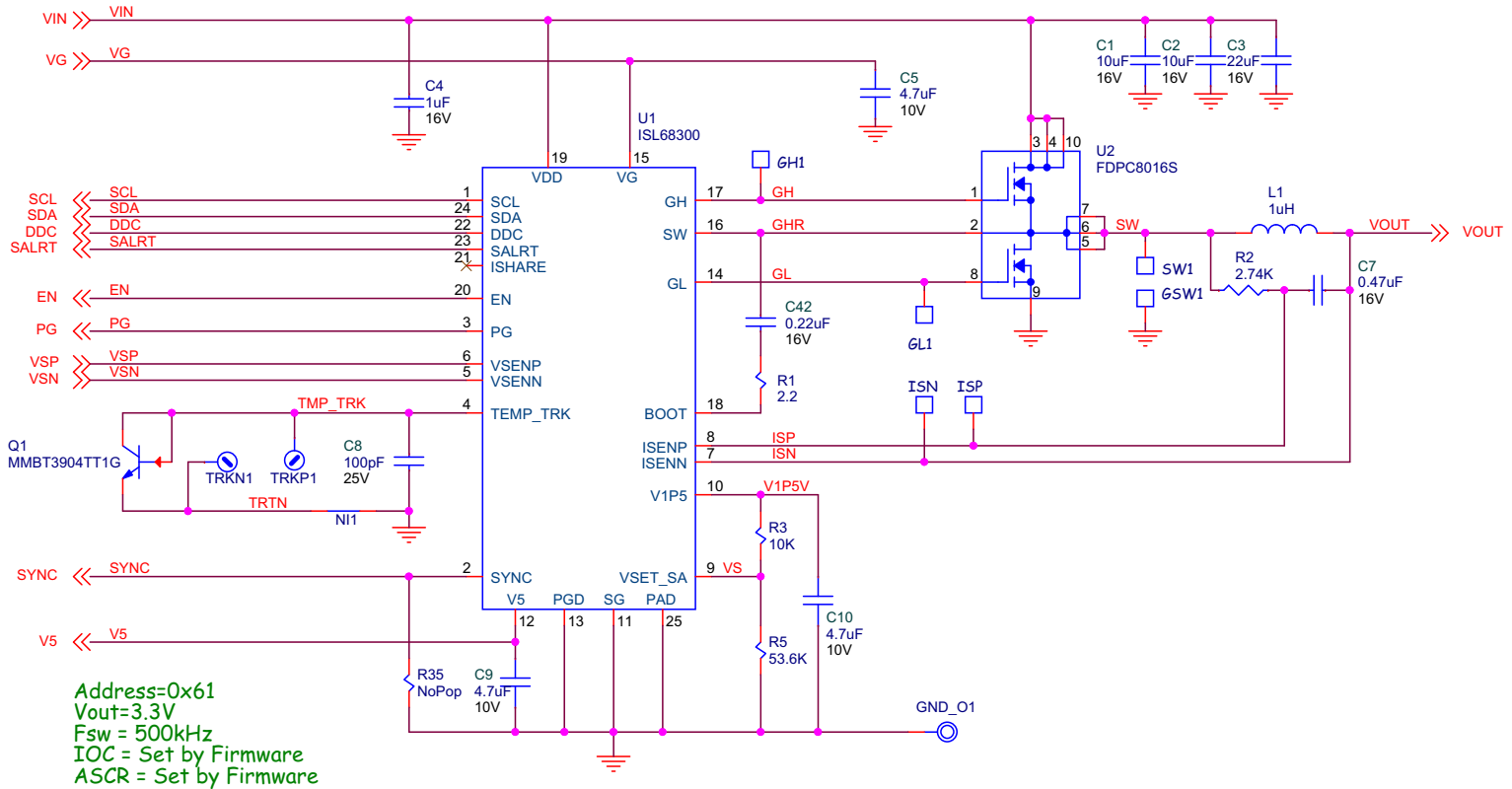

Figure 4. Schematic

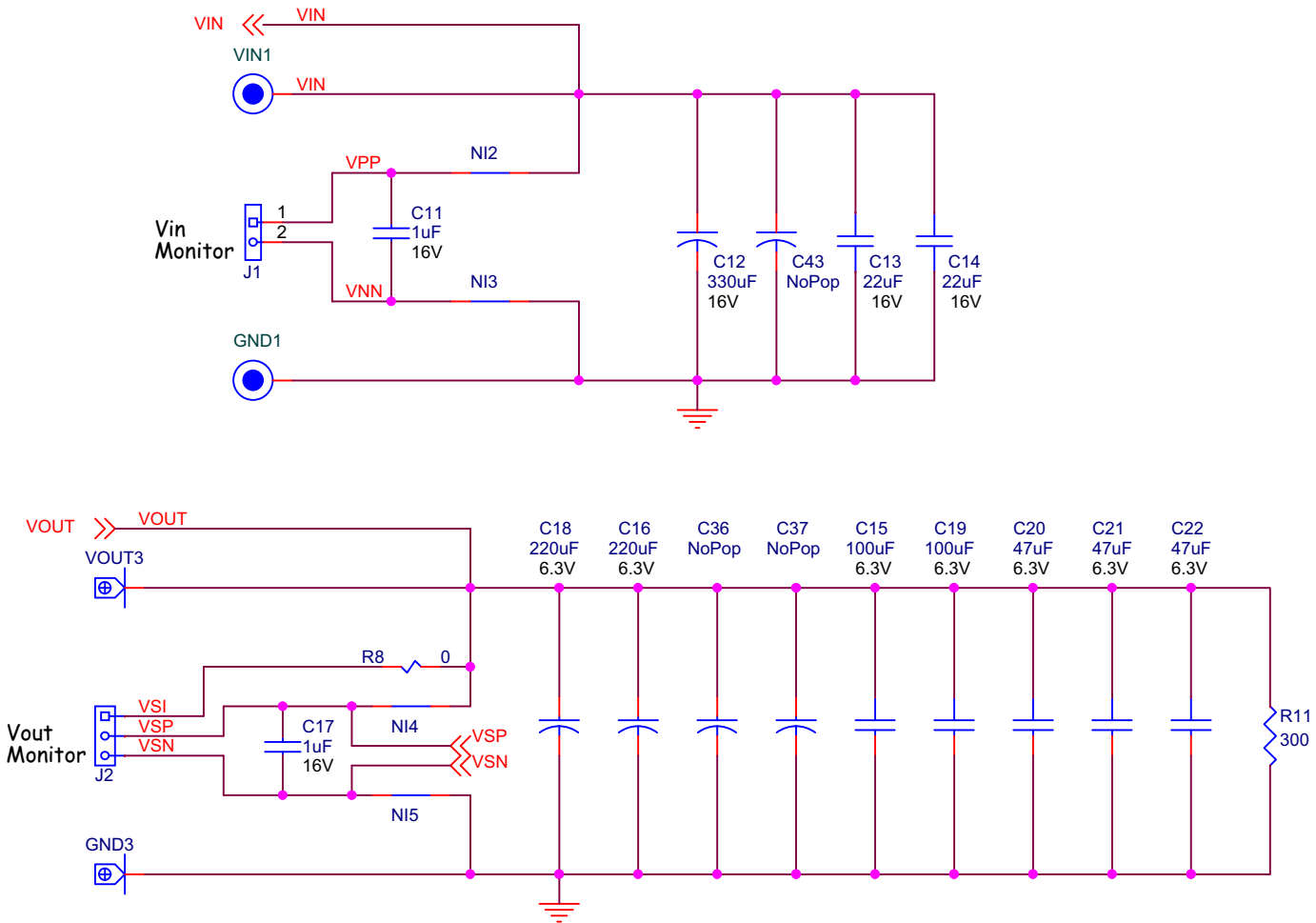

Figure 5. Schematic - Input and Output Filters

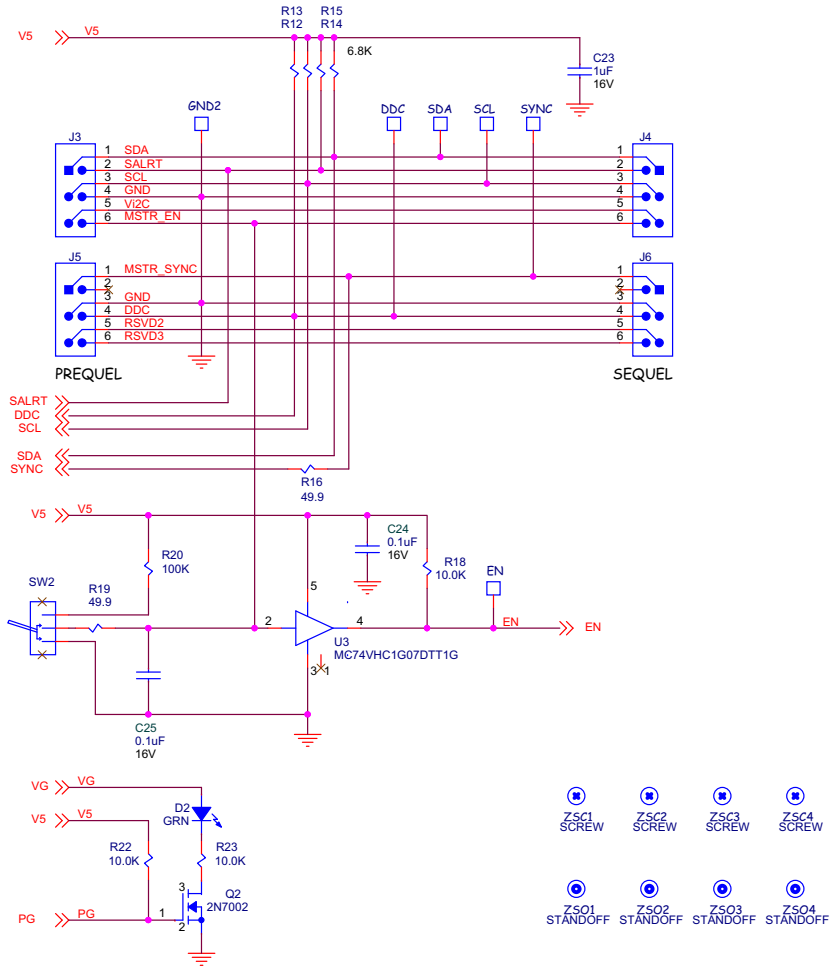

Figure 6. Schematic - I²C, Enable, PG

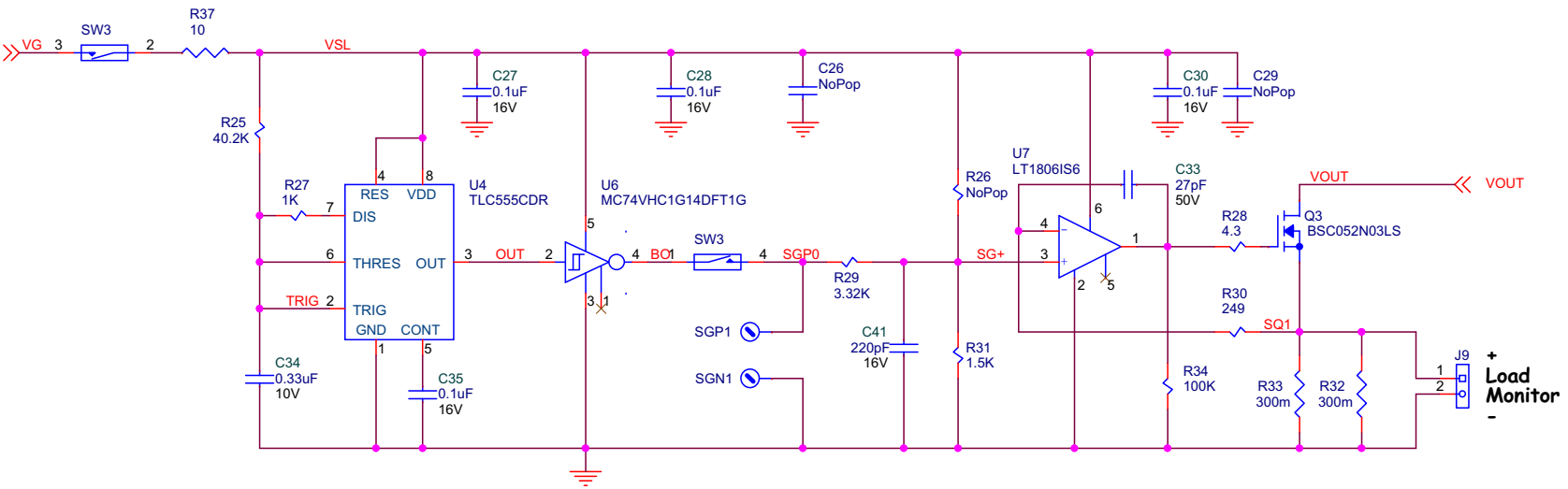

Figure 7. Schematic - Dynamic Load

3.2 Bill of Materials

Qty	Reference Designator	Description	Manufacturer	Manufacturer Part
2	C1, C2	CAP, SMD, 0805, 10µF, 16V, 10%, X6S, ROHS	TDK	C2012X6S1C106K085AC
2	C15, C19	CAP, SMD, 1206, 150µF, 6.3V, 20%, X5R, ROHS	Murata	GRM31CR60J157ME11L
1	C40	CAP, SMD, 0402, 1000pF, 50V, 5%, C0G, ROHS	Venkel	C0402C0G500-102JNE
6	C24, C25, C27, C28, C30, C35	CAP, SMD, 0402, 0.1µF, 16V, 10%, X7R, ROHS	Venkel	C0402X7R160-104KNE
4	C4, C11, C17, C23	CAP, SMD, 0402, 1.0µF, 16V, 10%, X5R, ROHS	TDK	C1005X5R1C105K050BC
1	C41	CAP, SMD, 0402, 220pF, 50V, 5%, C0G, ROHS	Panasonic	ECU-E1H221JCQ
1	C42	CAP, SMD, 0402, 0.22µF, 10V, 10%, X5R, ROHS	Venkel	C0402X5R100-224KNE
1	C33	CAP, SMD, 0402, 27pF, 50V, 5%, NP0, ROHS	Murata	GRM36COG270J050AQ
1	C34	CAP, SMD, 0402, 0.33µF, 6.3V, 10%, X5R, ROHS	Murata	GRM155R60J334KE01J
1	C8	CAP, SMD, 0402, 100pF, 25V, 5%, NP0, ROHS	AVX	04023A101FAT2A
1	C7	CAP, SMD, 0402, 0.47µF, 6.3V, 10%, X7R, ROHS	Taiyo Yuden	JMK105B7474KVHF
3	C5, C9, C10	CAP, SMD, 0402, 4.7µF, 10V, 10%, X5R, ROHS	TDK	C1005X5R1A475K050BC
3	C20, C21, C22	CAP, SMD, 0805, 47µF, 6.3V, 20%, X5R, ROHS	Kemet	C0805C476M9PACTU
3	C3, C13, C14	CAP, SMD, 1206, 22µF, 25V, 10%, X5R, ROHS	Murata	GRM31CR61E226KE15L
1	C12	CAP, SMD, 10X12, 330µF, 16V, 20%, 14mΩ, ALUM.ELEC., ROHS	Nippon Chemi-Con	APXA160ARA331MJC0G
2	C16, C18	CAP, SMD, D, 220µF, 6.3V, 20%, POLY.AL.ELE., ROHS	Panasonic	6TPF220M5L
1	L1	COIL-PWR INDUCTOR, SMD, 1µH, ROHS	Coilcraft	XAL1010-102MEB
1	D2	LED, SMD, 0805, GREEN/CLEAR, 2.2V, 20mA, 574nm, 45mcd, ROHS	Lumex	SML-LX0805SUGC-TR
1	U1	IC-DIGITAL DC/DC CONTROLLER, 24P, QFN, ROHS	Renesas	ISL68300IRAZ
1	U2	TRANSISTOR-MOS, DUAL N-CHNL, 8P, WDFN, 25V, 20A/35A, ROHS	On Semiconductor	FDPC8016S
1	U7	IC-OP AMP, R/R, SMD, 6P, TSOT23, 325MHz, 85mA, ROHS	Linear Technology	LT1806IS6#TRMPBF
1	U3	IC-NON-INVERTING BUFFER, SMD, 5P, TSOT23-5, ROHS	On Semiconductor	MC74VHC1G07DTT1G
1	U6	IC-INVERTER, SCHMITT TRIGGER, SMD, 5P, SC-70-5, ROHS	On Semiconductor	MC74VHC1G14DFT1G
1	U4	IC-TIMER/OSCILLATOR, 2.1MHz, SMD, 8P, SOIC, ROHS	Texas Instruments	TLC555CDR
1	Q1	TRANSISTOR-NPN, SMD, SOT-416, 200mA, 40V, 300mW, ROHS	On Semiconductor	MMBT3904TT1G
1	Q2	TRANSISTOR, N-CHANNEL, 3LD, SOT-23, 60V, 115mA, ROHS	Diodes, Inc.	2N7002-7-F
1	Q3	TRANSIST-MOS, N-CHANNEL, 30V, 57A, SMD, 8P, PG-TDSON-8, ROHS	Infineon Technology	BSC052N03LS
2	R32, R33	RES-AEC-Q200, CURR.SENSE, SMD, 2512, 0.3Ω, 2W, 1%, TF, ROHS	Bourns	CRM2512-FX-R300ELF
1	R28	RES, SMD, 0402, 4.3Ω, 1/16W, 5%, TF, ROHS	Vishay/Dale	CRCW04024R30FKED
1	R8	RES, SMD, 0402, 0Ω, 1/16W, 5%, TF, ROHS	Venkel	CR0402-16W-00T

Qty	Reference Designator	Description	Manufacturer	Manufacturer Part
1	R2	RES, SMD, 0603, 2.74k Ω , 1/10W, 1%, TF, ROHS	Venkel	CR0603-10W-2741FT
4	R3, R18, R22, R23	RES, SMD, 0402, 10k, 1/16W, 1%, TF, ROHS	Panasonic	ERJ-2RKF1002X
2	R20, R34	RES, SMD, 0402, 100k, 1/16W, 1%, TF, ROHS	Panasonic	ERJ2RKF1003
1	R31	RES, SMD, 0402, 1.5k Ω , 1/16W, 1%, TF, ROHS	Panasonic	ERJ-2RKF1501X
1	R1	RES, SMD, 0402, 2.2 Ω , 1/16W, 1%, TF, ROHS	Yageo	RC0402FR-072R2L
1	R27	RES, SMD, 0402, 1k, 1/16W, 1%, TF, ROHS	Venkel	CR0402-16W-1001FT
1	R30	RES, SMD, 0402, 249 Ω , 1/16W, 1%, TF, ROHS	Panasonic	ERJ-2RKF2490
1	R29	RES, SMD, 0402, 3.32k, 1/16W, 1%, TF, ROHS	Yageo	RC0402FR-073K32L
1	R25	RES, SMD, 0402, 40.2k, 1/16W, 1%, TF, ROHS	Venkel	CR0402-16W-4022FT
1	R5	RES, SMD, 0402, 53.6k, 1/16W, 1%, TF, ROHS	Panasonic	ERJ-2RKF5362X
2	R16, R19	RES, SMD, 0402, 49.9 Ω , 1/16W, 1%, TF, ROHS	Panasonic	ERJ-2RKF49R9X
4	R12, R13, R14, R15	RES, SMD, 0402, 6.8k, 1/16W, 1%, TF, ROHS	Panasonic	ERJ-2RKF6801X
1	R37	RES, SMD, 0603, 10 Ω , 1/10W, 1%, TF, ROHS	KOA	RK73H1JT10R0F
1	R11	RES, SMD, 0603, 300 Ω , 1/10W, 1%, TF, ROHS	Rohm	MCR03EZPFX3000
2	R16, R19	RES, SMD, 0402, 49.9 Ω , 1/16W, 1%, TF, ROHS	Panasonic	ERJ-2RKF49R9X
1	SW2	SWITCH-TOGGLE, SPDT, TH, 5P, 28V, 0.4VA, ON-ON, ROHS	NKK	G12AP
1	SW3	SWITCH-SLIDE, SMD, 7.06mm, 2POS, SPST, 25mA, 24V, ROHS	C&K Components	SDA02H1SBD
2	GND3, VOUT3	HARDWARE, 65A PCB WIRE LUG, TH/SMD, 8.5x3.5, 6-14AWG, ROHS	International Hydraulics Inc	B6A-PCB-SS
2	VIN1, GND1	CONN-JACK, BANANA-SS-SDRLESS, VERTICAL, 0.53Length, ROHS	Johnson Components	108-0740-001
1	GND_O	CONN-DBL TURRET, TH, 0.218x0.078 PCB MNT, TIN/BRASS, ROHS	Keystone	1502-1
2	TRKP, SGP	CONN-MINI TEST PT, VERTICAL, RED, ROHS	Keystone	5000
2	TRKN, SGN	CONN-MINI TEST PT, VERTICAL, BLK, ROHS	Keystone	5001
2	J1, J9	CONN-HEADER, 1x2, RETENTIVE, 2.54mm, 0.230x0.120, ROHS	BERG/FCI	69190-202HLF
1	J2	CONN-HEADER, 1x3, BRKAWY 1x36, 2.54mm, TAIL LENGTH.145"	3M	929647-09-36-I-1X3
2	J4, J6	CONN-SOCKET STRIP, TH, 2x3, 2.54mm, TIN, R/A, ROHS	Samtec	SSQ-103-02-T-D-RA
2	J3, J5	CONN-HEADER, 2x3, BRKAWY, 2.54mm, TIN, R/A, ROHS	Samtec	TSW-103-08-T-D-RA
4	ZSC1, ZSC2, ZSC3, ZSC4	SCREW, 4-40x1/4in, PHILLIPS, PANHEAD, STAINLESS, ROHS	Building Fasteners	PMSSS 440 0025 PH
4	ZSO1, ZSO2, ZSO3, ZSO4	STANDOFF, 4-40x3/4in, F/F, HEX, ALUMINUM, 0.25 OD, ROHS	Keystone	2204
0	C26, C29, C43	DO NOT POPULATE		
0	R26, R35	DO NOT POPULATE		

3.3 ISL68300EVAL2Z Board Layout

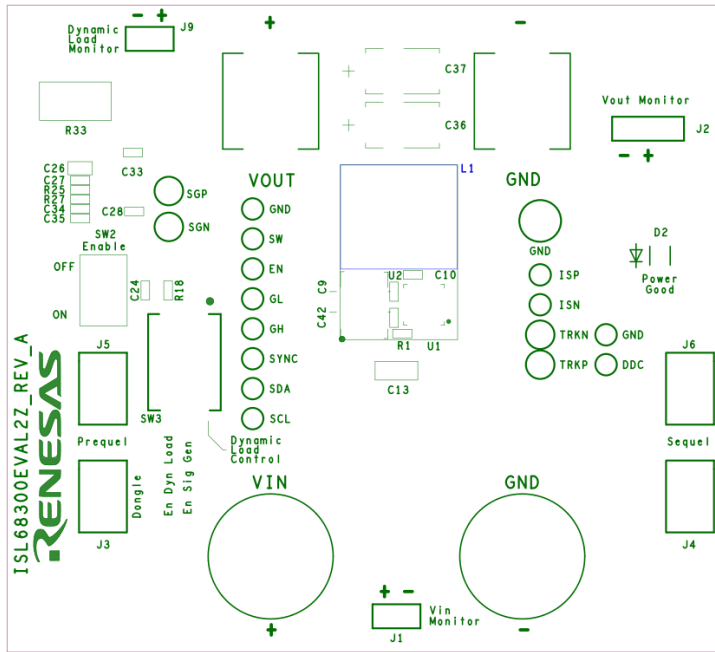

Figure 8. PCB - Top Silk Screen

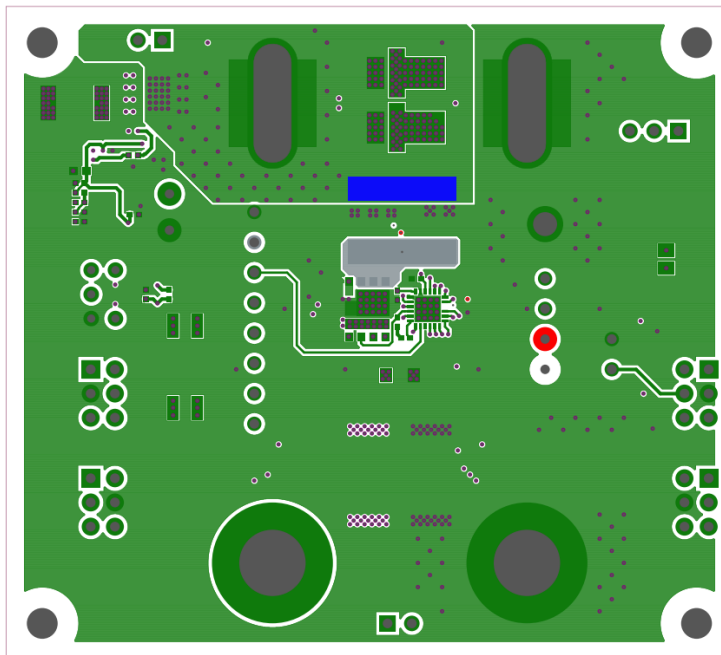

Figure 9. PCB - Top Layer

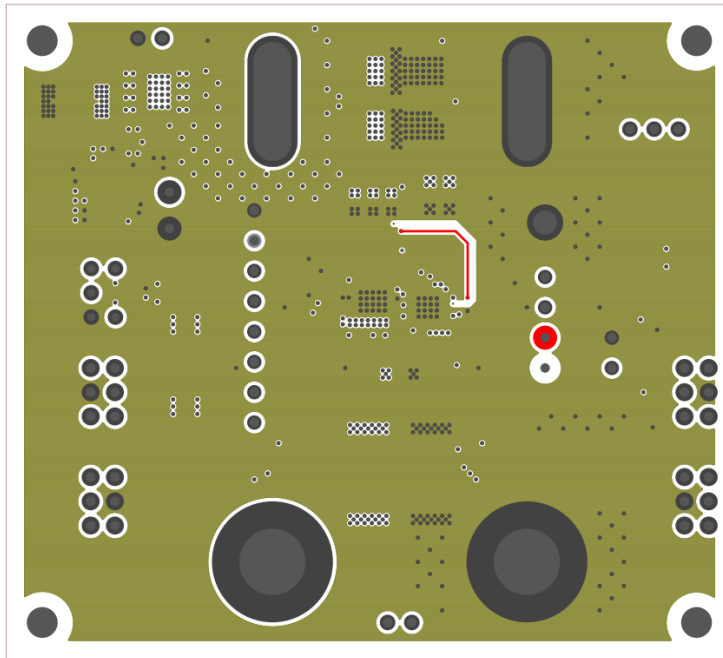

Figure 10. PCB - Inner Layer - Layer 2 (Top View)

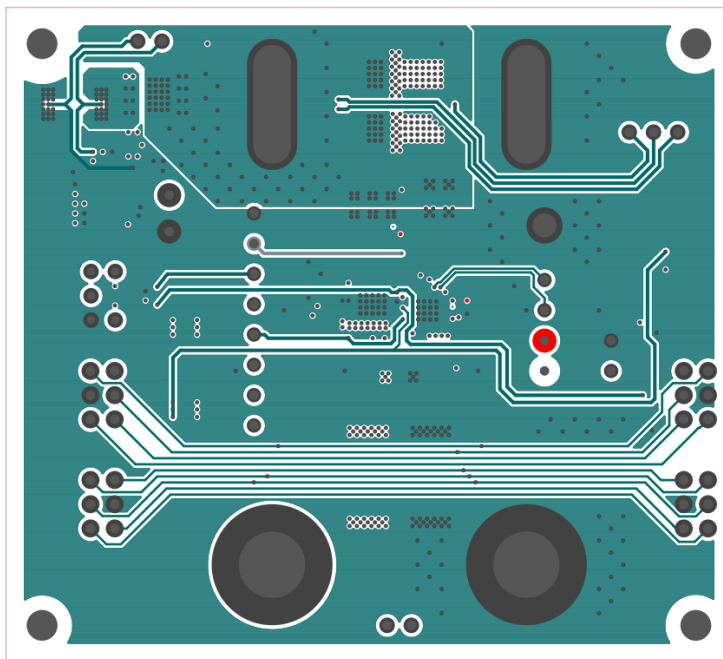

Figure 11. PCB - Inner Layer - Layer 3 (Top View)

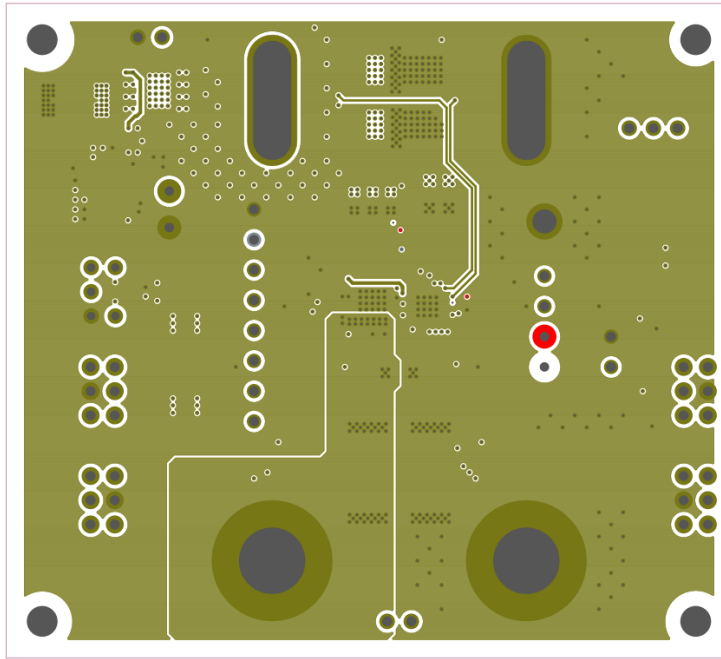

Figure 12. PCB - Inner Layer - Layer 4 (Top View)

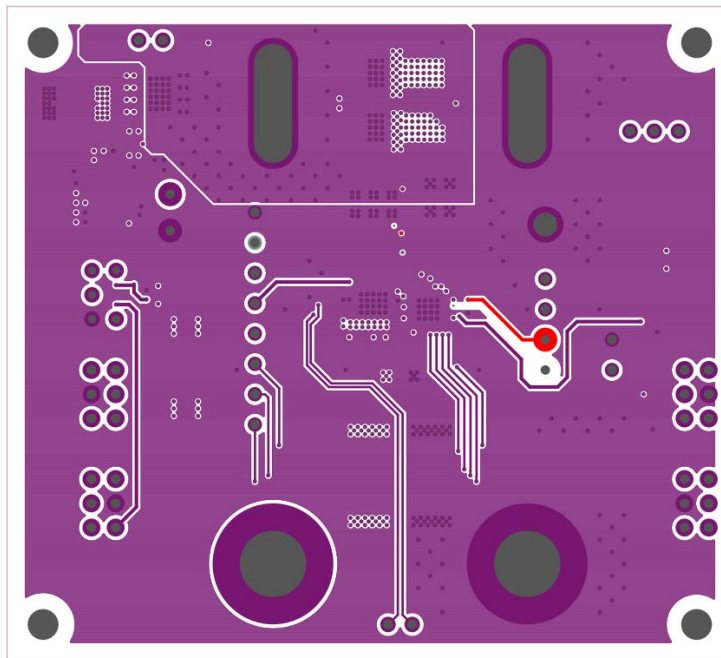

Figure 13. PCB - Inner Layer - Layer 5 (Top View)

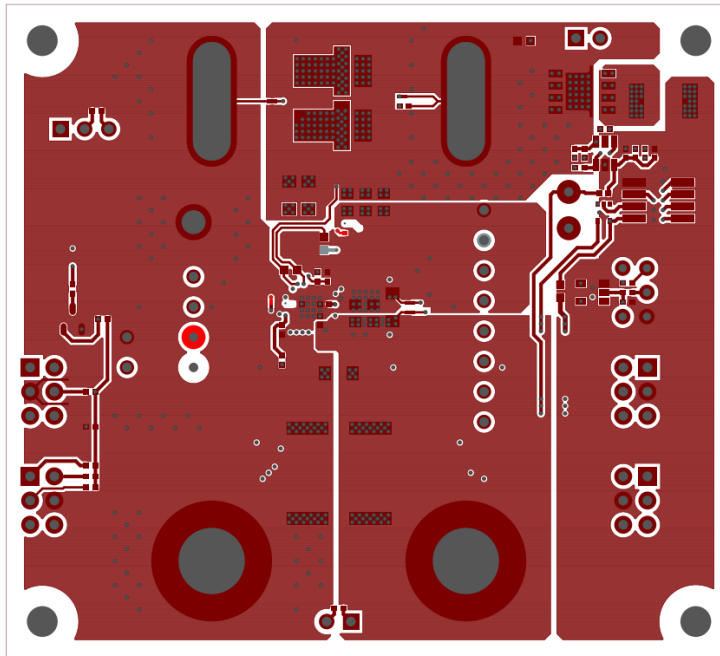

Figure 14. PCB - Bottom Layer (Top View)

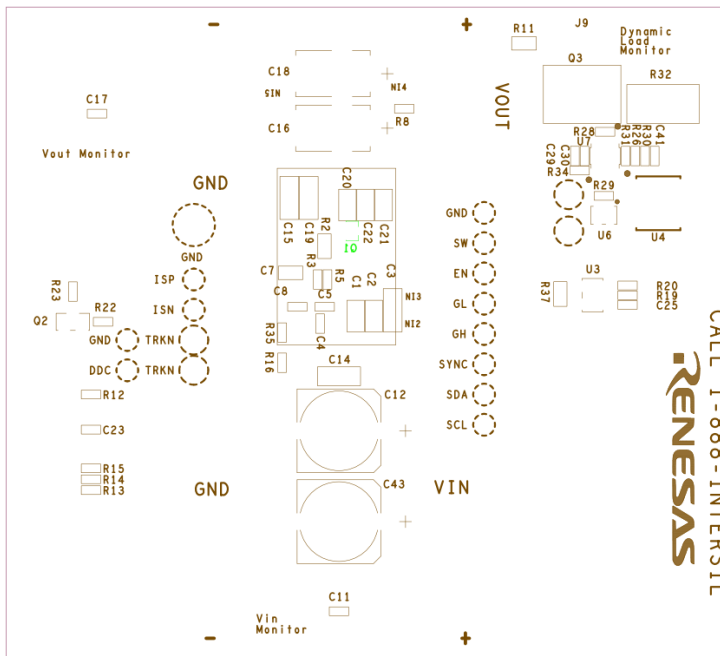

Figure 15. PCB - Bottom Silk Screen

4. Typical Performance Curves

Unless noted: $V_{IN} = 12V$, $T_A = +25^\circ C$

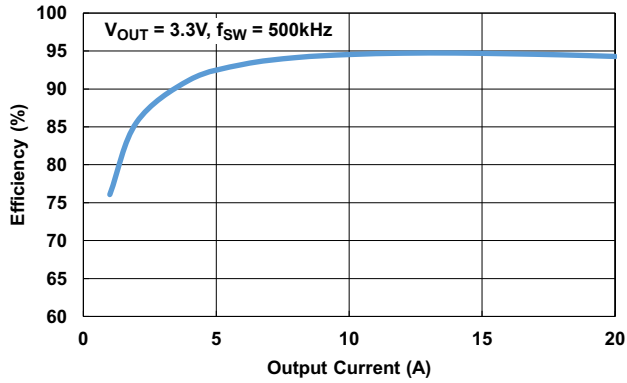

Figure 16. Efficiency

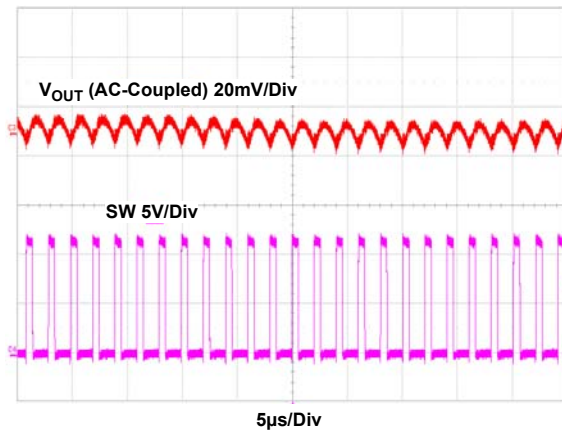

Figure 17. Output Ripple at Full Load

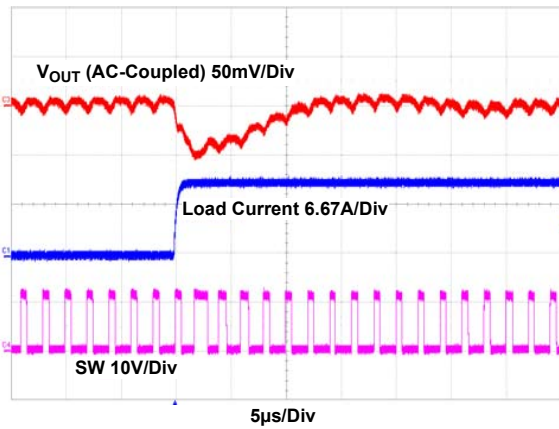

Figure 18. Load Transient Waveforms

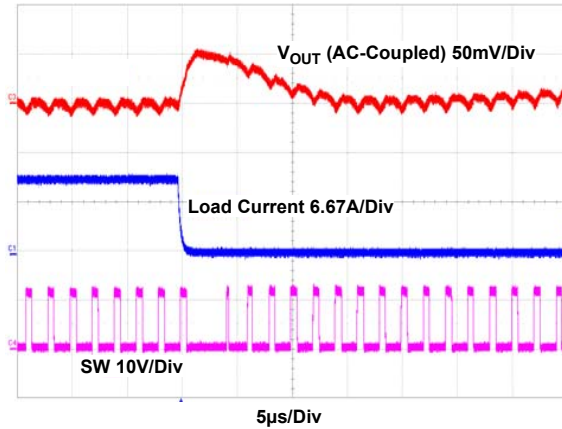

Figure 19. Load Transient Waveforms

5. Configuration File

Sample configuration file for the ISL68300. Copy and paste (from STORE_CONTROL to ### End User Store) to a text editor and save it as Confile_file_name.txt. The # symbol is used for a comment line.

```

STORE_CONTROL          0x21
STORE_CONTROL          0x11
STORE_CONTROL          0x12
# -----Start of User Settings-----
ON_OFF_CONFIG          0x17
VOUT_COMMAND           0x699A    # 3.3 V
VOUT_MAX               0xA000    # 5 V
VOUT_MARGIN_HIGH       0x6EDC    # 3.464 V
VOUT_MARGIN_LOW        0x6451    # 3.135 V
FREQUENCY_SWITCH       0xFBE8    # 500 kHz
POWER_MODE             0x00
IOUT_CAL_GAIN          0xBA3D    # 1.119 mV/A
VOUT_OV_FAULT_LIMIT    0x7425    # 3.63 V
VOUT_OV_FAULT_RESPONSE 0x80
VOUT_OV_WARN_LIMIT     0x7208    # 3.563 V
VOUT_UV_WARN_LIMIT     0x5CEA    # 2.904 V
VOUT_UV_FAULT_LIMIT    0x59BF    # 2.805 V
VOUT_UV_FAULT_RESPONSE 0x80
OT_FAULT_RESPONSE      0x80
UT_FAULT_RESPONSE      0x80
VIN_OV_FAULT_RESPONSE  0x80
VIN_UV_FAULT_RESPONSE  0x80
POWER_GOOD_ON          0x5F08    # 2.97 V
ISENSE_CONFIG          0x2902
USER_CONFIG            0x0040
ASCR_ADVANCED          0x20FF
INDUCTOR               0xBA00    # 1 µH
ASCR_CONFIG            0x3B5903E8
TRACK_CONFIG           0x00
MFR_IOUT_OC_FAULT_RESPONSE 0x80
MFR_IOUT_UC_FAULT_RESPONSE 0x80
# -----End of User Settings-----
# -----Store Setup - Do Not Modify-----
STORE_CONTROL          0x13
### End User Store

```

6. Revision History

Rev.	Date	Description
1.00	Jul 13, 2018	Updated board pictures. Updated Figure 5 and BOM (C43 information). Updated sample configuration file.
0.00	Jul 3, 2018	Initial release

Notice

1. Descriptions of circuits, software and other related information in this document are provided only to illustrate the operation of semiconductor products and application examples. You are fully responsible for the incorporation or any other use of the circuits, software, and information in the design of your product or system. Renesas Electronics disclaims any and all liability for any losses and damages incurred by you or third parties arising from the use of these circuits, software, or information.
2. Renesas Electronics hereby expressly disclaims any warranties against and liability for infringement or any other claims involving patents, copyrights, or other intellectual property rights of third parties, by or arising from the use of Renesas Electronics products or technical information described in this document, including but not limited to, the product data, drawings, charts, programs, algorithms, and application examples.
3. No license, express, implied or otherwise, is granted hereby under any patents, copyrights or other intellectual property rights of Renesas Electronics or others.
4. You shall not alter, modify, copy, or reverse engineer any Renesas Electronics product, whether in whole or in part. Renesas Electronics disclaims any and all liability for any losses or damages incurred by you or third parties arising from such alteration, modification, copying or reverse engineering.
5. Renesas Electronics products are classified according to the following two quality grades: "Standard" and "High Quality". The intended applications for each Renesas Electronics product depends on the product's quality grade, as indicated below.
"Standard": Computers; office equipment; communications equipment; test and measurement equipment; audio and visual equipment; home electronic appliances; machine tools; personal electronic equipment; industrial robots; etc.
"High Quality": Transportation equipment (automobiles, trains, ships, etc.); traffic control (traffic lights); large-scale communication equipment; key financial terminal systems; safety control equipment; etc.
Unless expressly designated as a high reliability product or a product for harsh environments in a Renesas Electronics data sheet or other Renesas Electronics document, Renesas Electronics products are not intended or authorized for use in products or systems that may pose a direct threat to human life or bodily injury (artificial life support devices or systems; surgical implantations; etc.), or may cause serious property damage (space system; undersea repeaters; nuclear power control systems; aircraft control systems; key plant systems; military equipment; etc.). Renesas Electronics disclaims any and all liability for any damages or losses incurred by you or any third parties arising from the use of any Renesas Electronics product that is inconsistent with any Renesas Electronics data sheet, user's manual or other Renesas Electronics document.
6. When using Renesas Electronics products, refer to the latest product information (data sheets, user's manuals, application notes, "General Notes for Handling and Using Semiconductor Devices" in the reliability handbook, etc.), and ensure that usage conditions are within the ranges specified by Renesas Electronics with respect to maximum ratings, operating power supply voltage range, heat dissipation characteristics, installation, etc. Renesas Electronics disclaims any and all liability for any malfunctions, failure or accident arising out of the use of Renesas Electronics products outside of such specified ranges.
7. Although Renesas Electronics endeavors to improve the quality and reliability of Renesas Electronics products, semiconductor products have specific characteristics, such as the occurrence of failure at a certain rate and malfunctions under certain use conditions. Unless designated as a high reliability product or a product for harsh environments in a Renesas Electronics data sheet or other Renesas Electronics document, Renesas Electronics products are not subject to radiation resistance design. You are responsible for implementing safety measures to guard against the possibility of bodily injury, injury or damage caused by fire, and/or danger to the public in the event of a failure or malfunction of Renesas Electronics products, such as safety design for hardware and software, including but not limited to redundancy, fire control and malfunction prevention, appropriate treatment for aging degradation or any other appropriate measures. Because the evaluation of microcomputer software alone is very difficult and impractical, you are responsible for evaluating the safety of the final products or systems manufactured by you.
8. Please contact a Renesas Electronics sales office for details as to environmental matters such as the environmental compatibility of each Renesas Electronics product. You are responsible for carefully and sufficiently investigating applicable laws and regulations that regulate the inclusion or use of controlled substances, including without limitation, the EU RoHS Directive, and using Renesas Electronics products in compliance with all these applicable laws and regulations. Renesas Electronics disclaims any and all liability for damages or losses occurring as a result of your noncompliance with applicable laws and regulations.
9. Renesas Electronics products and technologies shall not be used for or incorporated into any products or systems whose manufacture, use, or sale is prohibited under any applicable domestic or foreign laws or regulations. You shall comply with any applicable export control laws and regulations promulgated and administered by the governments of any countries asserting jurisdiction over the parties or transactions.
10. It is the responsibility of the buyer or distributor of Renesas Electronics products, or any other party who distributes, disposes of, or otherwise sells or transfers the product to a third party, to notify such third party in advance of the contents and conditions set forth in this document.
11. This document shall not be reprinted, reproduced or duplicated in any form, in whole or in part, without prior written consent of Renesas Electronics.
12. Please contact a Renesas Electronics sales office if you have any questions regarding the information contained in this document or Renesas Electronics products.
(Note 1) "Renesas Electronics" as used in this document means Renesas Electronics Corporation and also includes its directly or indirectly controlled subsidiaries.
(Note 2) "Renesas Electronics product(s)" means any product developed or manufactured by or for Renesas Electronics.

(Rev.4.0-1 November 2017)



SALES OFFICES

Renesas Electronics Corporation

<http://www.renesas.com>

Refer to "<http://www.renesas.com/>" for the latest and detailed information.

Renesas Electronics America Inc.

1001 Murphy Ranch Road, Milpitas, CA 95035, U.S.A.
Tel: +1-408-432-8888, Fax: +1-408-434-5351

Renesas Electronics Canada Limited

9251 Yonge Street, Suite 8309 Richmond Hill, Ontario Canada L4C 9T3
Tel: +1-905-237-2004

Renesas Electronics Europe Limited

Dukes Meadow, Millboard Road, Bourne End, Buckinghamshire, SL8 5FH, U.K
Tel: +44-1628-651-700, Fax: +44-1628-651-804

Renesas Electronics Europe GmbH

Arcadiastrasse 10, 40472 Düsseldorf, Germany
Tel: +49-211-6503-0, Fax: +49-211-6503-1327

Renesas Electronics (China) Co., Ltd.

Room 1709 Quantum Plaza, No.27 ZhichunLu, Haidian District, Beijing, 100191 P. R. China
Tel: +86-10-8235-1155, Fax: +86-10-8235-7679

Renesas Electronics (Shanghai) Co., Ltd.

Unit 301, Tower A, Central Towers, 555 Langao Road, Putuo District, Shanghai, 200333 P. R. China
Tel: +86-21-2226-0888, Fax: +86-21-2226-0999

Renesas Electronics Hong Kong Limited

Unit 1601-1611, 16/F., Tower 2, Grand Century Place, 193 Prince Edward Road West, Mongkok, Kowloon, Hong Kong
Tel: +852-2265-6688, Fax: +852 2886-9022

Renesas Electronics Taiwan Co., Ltd.

13F, No. 363, Fu Shing North Road, Taipei 10543, Taiwan
Tel: +886-2-8175-9600, Fax: +886 2-8175-9670

Renesas Electronics Singapore Pte. Ltd.

80 Bendemeer Road, Unit #06-02 Hyflux Innovation Centre, Singapore 339949
Tel: +65-6213-0200, Fax: +65-6213-0300

Renesas Electronics Malaysia Sdn.Bhd.

Unit 1207, Block B, Menara Amcorp, Amcorp Trade Centre, No. 18, Jln Persiaran Barat, 46050 Petaling Jaya, Selangor Darul Ehsan, Malaysia
Tel: +60-3-7955-9390, Fax: +60-3-7955-9510

Renesas Electronics India Pvt. Ltd.

No.777C, 100 Feet Road, HAL 2nd Stage, Indiranagar, Bangalore 560 038, India
Tel: +91-80-67208700, Fax: +91-80-67208777

Renesas Electronics Korea Co., Ltd.

17F, KAMCO Yangjae Tower, 262, Gangnam-daero, Gangnam-gu, Seoul, 06265 Korea
Tel: +82-2-558-3737, Fax: +82-2-558-5338

ISL68300EVAL2Z

