

## ISL9107EVAL1Z, ISL9108EVAL1Z

Evaluation Board Application Manual

AN1399  
Rev 0.00  
July 29, 2008

### Description

The ISL9107EVAL1Z and ISL9108EVAL1Z provide the complete evaluation kit for the ISL9107 and ISL9108, which are 1.6MHz switching frequency, low quiescent current, high efficiency integrated step-down regulators. They are capable of delivering up to 1.5A output current with an output voltage range from 0.8V to  $\sim V_{IN}$ . The output voltage is set by two voltage divider resistors of  $R_2$  and  $R_3$  on the board. The default output voltage is set to be 1.6V on the evaluation board. In addition to ISL9108, ISL9107 offers a typical 215ms Power-Good (PG) timer when powered up. This timer output can be reset by RSI.

The complete ISL9107, ISL9108 regulator is located at the center of the board. On the left side of the board are the connectors for the input power source ( $V_{IN}$  and GND). The output connectors are located on the right side ( $V_O$  and GND). The other two test points are for the PG and RSI signals respectively (for ISL9107 only), as labelled on the board. The RSI input needs either be driven to a low or a high logic input (Please refer to the ISL9107, ISL9108 datasheet, FN6612, for more details regarding the RSI function). On the board, the open-drain PG signal is pulled up to the  $V_{IN}$  through a 100k $\Omega$  resistor ( $R_1$ ). Jumper JP1 allows the user to enable or disable the IC. Jumper JP2 is the mode selection input. **Do not leave the EN and the MODE signal floating.** The evaluation board also offers one oscilloscope probe tip connector connected to SW pin to minimize the switching noise during the evaluation. The evaluation board schematic, layout and bill-of-materials (BOM) can be found at the end of this application note.

### Ordering Information

- ISL9107EVAL1Z - Evaluation Board for ISL9107
- ISL9108EVAL1Z - Evaluation Board for ISL9108

### Features

- A Complete Evaluation Platform for ISL9107 and ISL9108
- Convenient Jumpers for Enable/Disable, Operation Mode Selection
- Integrated Synchronous Buck Regulator with High Efficiency
- 2.7V to 5.5V Supply Voltage
- 1.5A Output Current
- 17 $\mu$ A Quiescent Current in Skip (Low  $I_Q$ ) Mode

### Specifications

Table 1 below shows the recommended operating conditions for using ISL9107EVAL1Z, ISL9108EVAL1Z.

TABLE 1. RECOMMENDED OPERATING CONDITIONS

PARAMETER	MIN	TYP	MAX	UNIT
Input Voltage	2.7	-	5.5	V
Output Voltage (Note)	-	1.6	-	V
Maximum Output Current	1.5	-	-	A

NOTE: The output voltage can be set to other values by changing the  $R_2$ ,  $R_3$  values,  $V_{OUT} = 0.8V \cdot (1 + R_2/R_3)$ . Refer to ISL9107, ISL9108 datasheet for some recommended  $R_2$ ,  $R_3$  and  $C_3$  values for different output voltages.

### Recommended Equipment

The following instruments are recommended for testing:

- DC Power Supply, 5V/3A
- Electronic loads capable of sinking current up to 4A
- Multimeters
- Function generator
- Oscilloscope

### Evaluation Board Setup

The following are recommended steps for setting up the ISL9107EVAL1Z and ISL9108EVAL1Z evaluation boards:

1. Connect Jumper JP1 at the position of "Enable" to enable the device. Connect JP1 at the position of "Disable" to disable the device.
2. Connect Jumper JP2 either at the position of "SKIP" or "PWM". With JP2 connected at the position of "SKIP", the device enters skip mode under light load condition; with JP2 connected at the position of "PWM", the device always operates under PWM mode regardless of the load condition.
3. For ISL9107EVAL1Z, connect the RSI input to either ground or  $V_{IN}$ . Please refer to the ISL9107, ISL9108 datasheet, FN6612, for more details regarding the function of RSI.
4. Connect DC power supply between  $V_{IN}$  and GND connectors on board. Make sure the power supply has enough supply current capability. The absolute maximum rating for  $V_{IN}$  pin is 6.5V and the recommended maximum input voltage applied on  $V_{IN}$  is up to 5.5V.
5. Connect the output to a load (resistor or electronic load).
6. Turn on the input power supply and start the evaluation.

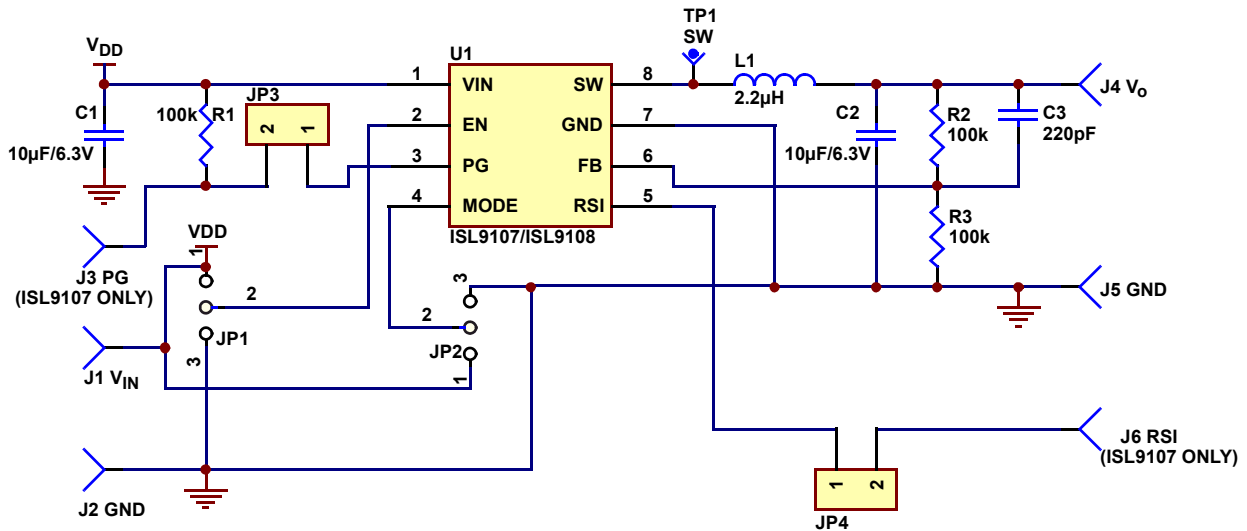

J3, J6, JP3 AND JP4 ARE ONLY POPULATED FOR ISL9107EVAL1Z. FOR ISL9108EVAL1Z, THESE SHOULD BE UN-POPULATED ON THE BOARD.

FIGURE 1. ISL9107EVAL1Z, ISL9108EVAL1Z SCHEMATIC

**ISL9107EVAL1Z and ISL9108EVAL1Z Bill of Materials (BOM)**

ITEM	QTY	REFERENCE	PART DESCRIPTION	PCB FOOTPRINT	PART NUMBER	VENDOR
1	1	U1	ISL9107 for ISL9107EVAL1Z and ISL9108 for ISL9108EVAL1Z	8 Ld (2x3) DFN	ISL9107 or ISL9108	Intersil
2	1	C1	Capacitor, SMD, 10µF/6.3V, 10%, X5R	0805	GRM21BR60J106KE19L	Murata
3	1	C2	Capacitor, SMD, 10µF/6.3V, 10%, X5R	0805	GRM21BR60J106KE19L	Murata
4	1	C3	Capacitor, SMD, 220pF/50V, 10%, X7R	0603	GRM188R71H221KA01D	Murata
5	3	R1, R2, R3	Resistor, SMD, 100kΩ, 1%, 0.1W	0603	RC0603FR-07100KL	Yageo
6	1	L1	Inductor, 2.2µH	3.8x3.8	CDRH3D17/SNP-2R2	Sumida
7	6	VIN, VO, PG, RSI, GND (x2)	Turrent Terminal Pin. J3 (PG) and J6 (RSI) are only populated on ISL9107EVAL1Z.	-	3156-1-00-15-00-00-08-0	Mill-Max
8	1	TP1	Scope Probe Test Point	-	131503100	Tektronix
9	2	JP1, JP2	Connect Header, 1X3	-	68000-236-1X3	BERG/FCI
10	2	JP3, JP4	Connect Header, 1X2. Only populated for ISL9107EVAL1Z.	-	68000-236-1x2	BERG/FCI

**PCB Layout**

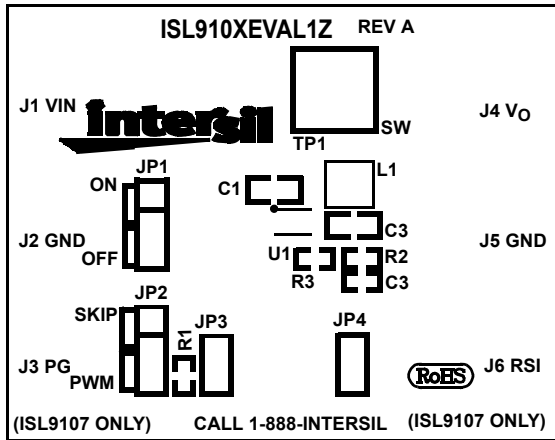

FIGURE 2. SILK LAYER

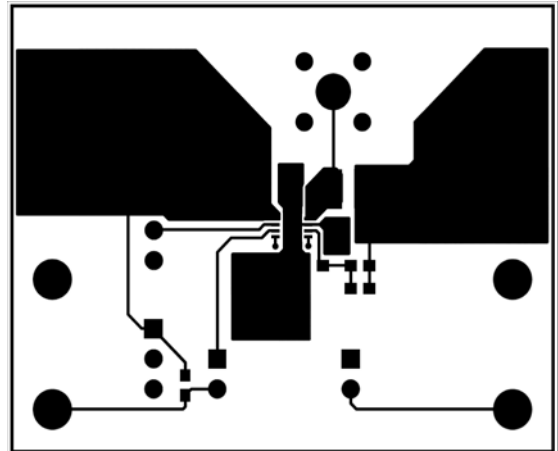

FIGURE 3. TOP LAYER

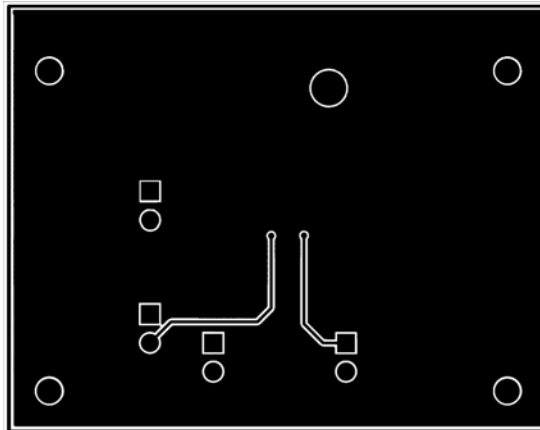

FIGURE 4. BOTTOM LAYER (Mirrored)

## Notice

1. Descriptions of circuits, software and other related information in this document are provided only to illustrate the operation of semiconductor products and application examples. You are fully responsible for the incorporation or any other use of the circuits, software, and information in the design of your product or system. Renesas Electronics disclaims any and all liability for any losses and damages incurred by you or third parties arising from the use of these circuits, software, or information.
2. Renesas Electronics hereby expressly disclaims any warranties against and liability for infringement or any other claims involving patents, copyrights, or other intellectual property rights of third parties, by or arising from the use of Renesas Electronics products or technical information described in this document, including but not limited to, the product data, drawings, charts, programs, algorithms, and application examples.
3. No license, express, implied or otherwise, is granted hereby under any patents, copyrights or other intellectual property rights of Renesas Electronics or others.
4. You shall not alter, modify, copy, or reverse engineer any Renesas Electronics product, whether in whole or in part. Renesas Electronics disclaims any and all liability for any losses or damages incurred by you or third parties arising from such alteration, modification, copying or reverse engineering.
5. Renesas Electronics products are classified according to the following two quality grades: "Standard" and "High Quality". The intended applications for each Renesas Electronics product depends on the product's quality grade, as indicated below.  
"Standard": Computers; office equipment; communications equipment; test and measurement equipment; audio and visual equipment; home electronic appliances; machine tools; personal electronic equipment; industrial robots; etc.  
"High Quality": Transportation equipment (automobiles, trains, ships, etc.); traffic control (traffic lights); large-scale communication equipment; key financial terminal systems; safety control equipment; etc.  
Unless expressly designated as a high reliability product or a product for harsh environments in a Renesas Electronics data sheet or other Renesas Electronics document, Renesas Electronics products are not intended or authorized for use in products or systems that may pose a direct threat to human life or bodily injury (artificial life support devices or systems; surgical implantations; etc.), or may cause serious property damage (space system; undersea repeaters; nuclear power control systems; aircraft control systems; key plant systems; military equipment; etc.). Renesas Electronics disclaims any and all liability for any damages or losses incurred by you or any third parties arising from the use of any Renesas Electronics product that is inconsistent with any Renesas Electronics data sheet, user's manual or other Renesas Electronics document.
6. When using Renesas Electronics products, refer to the latest product information (data sheets, user's manuals, application notes, "General Notes for Handling and Using Semiconductor Devices" in the reliability handbook, etc.), and ensure that usage conditions are within the ranges specified by Renesas Electronics with respect to maximum ratings, operating power supply voltage range, heat dissipation characteristics, installation, etc. Renesas Electronics disclaims any and all liability for any malfunctions, failure or accident arising out of the use of Renesas Electronics products outside of such specified ranges.
7. Although Renesas Electronics endeavors to improve the quality and reliability of Renesas Electronics products, semiconductor products have specific characteristics, such as the occurrence of failure at a certain rate and malfunctions under certain use conditions. Unless designated as a high reliability product or a product for harsh environments in a Renesas Electronics data sheet or other Renesas Electronics document, Renesas Electronics products are not subject to radiation resistance design. You are responsible for implementing safety measures to guard against the possibility of bodily injury, injury or damage caused by fire, and/or danger to the public in the event of a failure or malfunction of Renesas Electronics products, such as safety design for hardware and software, including but not limited to redundancy, fire control and malfunction prevention, appropriate treatment for aging degradation or any other appropriate measures. Because the evaluation of microcomputer software alone is very difficult and impractical, you are responsible for evaluating the safety of the final products or systems manufactured by you.
8. Please contact a Renesas Electronics sales office for details as to environmental matters such as the environmental compatibility of each Renesas Electronics product. You are responsible for carefully and sufficiently investigating applicable laws and regulations that regulate the inclusion or use of controlled substances, including without limitation, the EU RoHS Directive, and using Renesas Electronics products in compliance with all these applicable laws and regulations. Renesas Electronics disclaims any and all liability for damages or losses occurring as a result of your noncompliance with applicable laws and regulations.
9. Renesas Electronics products and technologies shall not be used for or incorporated into any products or systems whose manufacture, use, or sale is prohibited under any applicable domestic or foreign laws or regulations. You shall comply with any applicable export control laws and regulations promulgated and administered by the governments of any countries asserting jurisdiction over the parties or transactions.
10. It is the responsibility of the buyer or distributor of Renesas Electronics products, or any other party who distributes, disposes of, or otherwise sells or transfers the product to a third party, to notify such third party in advance of the contents and conditions set forth in this document.
11. This document shall not be reprinted, reproduced or duplicated in any form, in whole or in part, without prior written consent of Renesas Electronics.
12. Please contact a Renesas Electronics sales office if you have any questions regarding the information contained in this document or Renesas Electronics products.  
(Note 1) "Renesas Electronics" as used in this document means Renesas Electronics Corporation and also includes its directly or indirectly controlled subsidiaries.  
(Note 2) "Renesas Electronics product(s)" means any product developed or manufactured by or for Renesas Electronics.

(Rev.4.0-1 November 2017)



### SALES OFFICES

Renesas Electronics Corporation

<http://www.renesas.com>

Refer to "<http://www.renesas.com/>" for the latest and detailed information.

**Renesas Electronics America Inc.**  
1001 Murphy Ranch Road, Milpitas, CA 95035, U.S.A.  
Tel: +1-408-432-8888, Fax: +1-408-434-5351

**Renesas Electronics Canada Limited**  
9251 Yonge Street, Suite 8309 Richmond Hill, Ontario Canada L4C 9T3  
Tel: +1-905-237-2004

**Renesas Electronics Europe Limited**  
Dukes Meadow, Millboard Road, Bourne End, Buckinghamshire, SL8 5FH, U.K  
Tel: +44-1628-651-700, Fax: +44-1628-651-804

**Renesas Electronics Europe GmbH**  
Arcadiastrasse 10, 40472 Düsseldorf, Germany  
Tel: +49-211-6503-0, Fax: +49-211-6503-1327

**Renesas Electronics (China) Co., Ltd.**  
Room 1709 Quantum Plaza, No.27 ZhichunLu, Haidian District, Beijing, 100191 P. R. China  
Tel: +86-10-8235-1155, Fax: +86-10-8235-7679

**Renesas Electronics (Shanghai) Co., Ltd.**  
Unit 301, Tower A, Central Towers, 555 Langao Road, Putuo District, Shanghai, 200333 P. R. China  
Tel: +86-21-2226-0888, Fax: +86-21-2226-0999

**Renesas Electronics Hong Kong Limited**  
Unit 1601-1611, 16/F., Tower 2, Grand Century Place, 193 Prince Edward Road West, Mongkok, Kowloon, Hong Kong  
Tel: +852-2265-6688, Fax: +852-2886-9022

**Renesas Electronics Taiwan Co., Ltd.**  
13F, No. 363, Fu Shing North Road, Taipei 10543, Taiwan  
Tel: +886-2-8175-9600, Fax: +886-2-8175-9670

**Renesas Electronics Singapore Pte. Ltd.**  
80 Bendemeer Road, Unit #06-02 Hyflux Innovation Centre, Singapore 339949  
Tel: +65-6213-0200, Fax: +65-6213-0300

**Renesas Electronics Malaysia Sdn.Bhd.**  
Unit 1207, Block B, Menara Amcorp, Amcorp Trade Centre, No. 18, Jln Persiaran Barat, 46050 Petaling Jaya, Selangor Darul Ehsan, Malaysia  
Tel: +60-3-7955-9390, Fax: +60-3-7955-9510

**Renesas Electronics India Pvt. Ltd.**  
No.777C, 100 Feet Road, HAL 2nd Stage, Indiranagar, Bangalore 560 038, India  
Tel: +91-80-67208700, Fax: +91-80-67208777

**Renesas Electronics Korea Co., Ltd.**  
17F, KAMCO Yangjae Tower, 262, Gangnam-daero, Gangnam-gu, Seoul, 06265 Korea  
Tel: +82-2-558-3737, Fax: +82-2-558-5338