

RL78/G23 Group

RL78/G23 Microcontroller Group
Inductive Proximity Sensor Shield
User's Manual

Renesas RL78 Family
G23 Series
Inductive Proximity Sensing Solution

All information contained in these materials, including products and product specifications, represents information on the product at the time of publication and is subject to change by Renesas Electronics Corp. without notice. Please review the latest information published by Renesas Electronics Corp. through various means, including the Renesas Electronics Corp. website (<http://www.renesas.com>).

Notice

1. Descriptions of circuits, software and other related information in this document are provided only to illustrate the operation of semiconductor products and application examples. You are fully responsible for the incorporation or any other use of the circuits, software, and information in the design of your product or system. Renesas Electronics disclaims any and all liability for any losses and damages incurred by you or third parties arising from the use of these circuits, software, or information.
2. Renesas Electronics hereby expressly disclaims any warranties against and liability for infringement or any other claims involving patents, copyrights, or other intellectual property rights of third parties, by or arising from the use of Renesas Electronics products or technical information described in this document, including but not limited to, the product data, drawings, charts, programs, algorithms, and application examples.
3. No license, express, implied or otherwise, is granted hereby under any patents, copyrights or other intellectual property rights of Renesas Electronics or others.
4. You shall be responsible for determining what licenses are required from any third parties, and obtaining such licenses for the lawful import, export, manufacture, sales, utilization, distribution or other disposal of any products incorporating Renesas Electronics products, if required.
5. You shall not alter, modify, copy, or reverse engineer any Renesas Electronics product, whether in whole or in part. Renesas Electronics disclaims any and all liability for any losses or damages incurred by you or third parties arising from such alteration, modification, copying or reverse engineering.
6. Renesas Electronics products are classified according to the following two quality grades: "Standard" and "High Quality". The intended applications for each Renesas Electronics product depends on the product's quality grade, as indicated below.

"Standard": Computers; office equipment; communications equipment; test and measurement equipment; audio and visual equipment; home electronic appliances; machine tools; personal electronic equipment; industrial robots; etc.

"High Quality": Transportation equipment (automobiles, trains, ships, etc.); traffic control (traffic lights); large-scale communication equipment; key financial terminal systems; safety control equipment; etc.

Unless expressly designated as a high reliability product or a product for harsh environments in a Renesas Electronics data sheet or other Renesas Electronics document, Renesas Electronics products are not intended or authorized for use in products or systems that may pose a direct threat to human life or bodily injury (artificial life support devices or systems; surgical implantations; etc.), or may cause serious property damage (space system; undersea repeaters; nuclear power control systems; aircraft control systems; key plant systems; military equipment; etc.). Renesas Electronics disclaims any and all liability for any damages or losses incurred by you or any third parties arising from the use of any Renesas Electronics product that is inconsistent with any Renesas Electronics data sheet, user's manual or other Renesas Electronics document.

7. No semiconductor product is absolutely secure. Notwithstanding any security measures or features that may be implemented in Renesas Electronics hardware or software products, Renesas Electronics shall have absolutely no liability arising out of any vulnerability or security breach, including but not limited to any unauthorized access to or use of a Renesas Electronics product or a system that uses a Renesas Electronics product. RENESAS ELECTRONICS DOES NOT WARRANT OR GUARANTEE THAT RENESAS ELECTRONICS PRODUCTS, OR ANY SYSTEMS CREATED USING RENESAS ELECTRONICS PRODUCTS WILL BE INVULNERABLE OR FREE FROM CORRUPTION, ATTACK, VIRUSES, INTERFERENCE, HACKING, DATA LOSS OR THEFT, OR OTHER SECURITY INTRUSION ("Vulnerability Issues"). RENESAS ELECTRONICS DISCLAIMS ANY AND ALL RESPONSIBILITY OR LIABILITY ARISING FROM OR RELATED TO ANY VULNERABILITY ISSUES. FURTHERMORE, TO THE EXTENT PERMITTED BY APPLICABLE LAW, RENESAS ELECTRONICS DISCLAIMS ANY AND ALL WARRANTIES, EXPRESS OR IMPLIED, WITH RESPECT TO THIS DOCUMENT AND ANY RELATED OR ACCOMPANYING SOFTWARE OR HARDWARE, INCLUDING BUT NOT LIMITED TO THE IMPLIED WARRANTIES OF MERCHANTABILITY, OR FITNESS FOR A PARTICULAR PURPOSE.
8. When using Renesas Electronics products, refer to the latest product information (data sheets, user's manuals, application notes, "General Notes for Handling and Using Semiconductor Devices" in the reliability handbook, etc.), and ensure that usage conditions are within the ranges specified by Renesas Electronics with respect to maximum ratings, operating power supply voltage range, heat dissipation characteristics, installation, etc. Renesas Electronics disclaims any and all liability for any malfunctions, failure or accident arising out of the use of Renesas Electronics products outside of such specified ranges.
9. Although Renesas Electronics endeavors to improve the quality and reliability of Renesas Electronics products, semiconductor products have specific characteristics, such as the occurrence of failure at a certain rate and malfunctions under certain use conditions. Unless designated as a high reliability product or a product for harsh environments in a Renesas Electronics data sheet or other Renesas Electronics document, Renesas Electronics products are not subject to radiation resistance design. You are responsible for implementing safety measures to guard against the possibility of bodily injury, injury or damage caused by fire, and/or danger to the public in the event of a failure or malfunction of Renesas Electronics products, such as safety design for hardware and software, including but not limited to redundancy, fire control and malfunction prevention, appropriate treatment for aging degradation or any other appropriate measures. Because the evaluation of microcomputer software alone is very difficult and impractical, you are responsible for evaluating the safety of the final products or systems manufactured by you.
10. Please contact a Renesas Electronics sales office for details as to environmental matters such as the environmental compatibility of each Renesas Electronics product. You are responsible for carefully and sufficiently investigating applicable laws and regulations that regulate the inclusion or use of controlled substances, including without limitation, the EU RoHS Directive, and using Renesas Electronics products in compliance with all these applicable laws and regulations. Renesas Electronics disclaims any and all liability for damages or losses occurring as a result of your noncompliance with applicable laws and regulations.
11. Renesas Electronics products and technologies shall not be used for or incorporated into any products or systems whose manufacture, use, or sale is prohibited under any applicable domestic or foreign laws or regulations. You shall comply with any applicable export control laws and regulations promulgated and administered by the governments of any countries asserting jurisdiction over the parties or transactions.
12. It is the responsibility of the buyer or distributor of Renesas Electronics products, or any other party who distributes, disposes of, or otherwise sells or transfers the product to a third party, to notify such third party in advance of the contents and conditions set forth in this document.
13. This document shall not be reprinted, reproduced or duplicated in any form, in whole or in part, without prior written consent of Renesas Electronics.
14. Please contact a Renesas Electronics sales office if you have any questions regarding the information contained in this document or Renesas Electronics products.

(Note1) "Renesas Electronics" as used in this document means Renesas Electronics Corporation and also includes its directly or indirectly controlled subsidiaries.

(Note2) "Renesas Electronics product(s)" means any product developed or manufactured by or for Renesas Electronics.

(Rev.5.0-1 October 2020)

Corporate Headquarters

TOYOSU FORESIA, 3-2-24 Toyosu,
Koto-ku, Tokyo 135-0061, Japan

www.renesas.com

Trademarks

Renesas and the Renesas logo are trademarks of Renesas Electronics Corporation. All trademarks and registered trademarks are the property of their respective owners.

Contact information

For further information on a product, technology, the most up-to-date version of a document, or your nearest sales office, please visit:

www.renesas.com/contact/.

General Precautions in the Handling of Microprocessing Unit and Microcontroller Unit Products

The following usage notes are applicable to all Microprocessing unit and Microcontroller unit products from Renesas. For detailed usage notes on the products covered by this document, refer to the relevant sections of the document as well as any technical updates that have been issued for the products.

1. Precaution against Electrostatic Discharge (ESD)

A strong electrical field, when exposed to a CMOS device, can cause destruction of the gate oxide and ultimately degrade the device operation. Steps must be taken to stop the generation of static electricity as much as possible, and quickly dissipate it when it occurs. Environmental control must be adequate. When it is dry, a humidifier should be used. This is recommended to avoid using insulators that can easily build up static electricity. Semiconductor devices must be stored and transported in an anti-static container, static shielding bag or conductive material. All test and measurement tools including work benches and floors must be grounded. The operator must also be grounded using a wrist strap. Semiconductor devices must not be touched with bare hands. Similar precautions must be taken for printed circuit boards with mounted semiconductor devices.

2. Processing at power-on

The state of the product is undefined at the time when power is supplied. The states of internal circuits in the LSI are indeterminate and the states of register settings and pins are undefined at the time when power is supplied. In a finished product where the reset signal is applied to the external reset pin, the states of pins are not guaranteed from the time when power is supplied until the reset process is completed. In a similar way, the states of pins in a product that is reset by an on-chip power-on reset function are not guaranteed from the time when power is supplied until the power reaches the level at which resetting is specified.

3. Input of signal during power-off state

Do not input signals or an I/O pull-up power supply while the device is powered off. The current injection that results from input of such a signal or I/O pull-up power supply may cause malfunction and the abnormal current that passes in the device at this time may cause degradation of internal elements. Follow the guideline for input signal during power-off state as described in your product documentation.

4. Handling of unused pins

Handle unused pins in accordance with the directions given under handling of unused pins in the manual. The input pins of CMOS products are generally in the high-impedance state. In operation with an unused pin in the open-circuit state, extra electromagnetic noise is induced in the vicinity of the LSI, an associated shoot-through current flows internally, and malfunctions occur due to the false recognition of the pin state as an input signal become possible.

5. Clock signals

After applying a reset, only release the reset line after the operating clock signal becomes stable. When switching the clock signal during program execution, wait until the target clock signal is stabilized. When the clock signal is generated with an external resonator or from an external oscillator during a reset, ensure that the reset line is only released after full stabilization of the clock signal. Additionally, when switching to a clock signal produced with an external resonator or by an external oscillator while program execution is in progress, wait until the target clock signal is stable.

6. Voltage application waveform at input pin

Waveform distortion due to input noise or a reflected wave may cause malfunction. If the input of the CMOS device stays in the area between V_{IL} (Max.) and V_{IH} (Min.) due to noise, for example, the device may malfunction. Take care to prevent chattering noise from entering the device when the input level is fixed, and also in the transition period when the input level passes through the area between V_{IL} (Max.) and V_{IH} (Min.).

7. Prohibition of access to reserved addresses

Access to reserved addresses is prohibited. The reserved addresses are provided for possible future expansion of functions. Do not access these addresses as the correct operation of the LSI is not guaranteed.

8. Differences between products

Before changing from one product to another, for example to a product with a different part number, confirm that the change will not lead to problems. The characteristics of a microprocessing unit or microcontroller unit products in the same group but having a different part number might differ in terms of internal memory capacity, layout pattern, and other factors, which can affect the ranges of electrical characteristics, such as characteristic values, operating margins, immunity to noise, and amount of radiated noise. When changing to a product with a different part number, implement a system-evaluation test for the given product.

Renesas Inductive Sense Shield Disclaimer

By using this Inductive Sense Shield, the User accepts the following terms, which are in addition to, and control in the event of disagreement, with Renesas' General Terms and Conditions available at <https://www.renesas.com/legal/disclaimer.html>.

The Inductive Sense Shield is not guaranteed to be error free, and the entire risk as to the results and performance of the Inductive Sense Shield is assumed by the User. The Inductive Sense Shield is provided by Renesas on an "as is" basis without warranty of any kind whether express or implied, including but not limited to the implied warranties of good workmanship, fitness for a particular purpose, title, merchantability, and non-infringement of intellectual property rights. Renesas expressly disclaims any implied warranty.

Renesas does not consider the Inductive Sense Shield to be a finished product and therefore the Inductive Sense Shield may not comply with some requirements applicable to finished products, including, but not limited to recycling, restricted substances and electromagnetic compatibility regulations. Refer to Certifications section, for information about certifications and compliance information for the Inductive Sense Shield. It is the kit User's responsibility to make sure the kit meets any local requirements applicable to their region.

Renesas or its affiliates shall in no event be liable for any loss of profit, loss of data, loss of contract, loss of business, damage to reputation or goodwill, any economic loss, any reprogramming or recall costs (whether the foregoing losses are direct or indirect) nor shall Renesas or its affiliates be liable for any other direct or indirect special, incidental or consequential damages arising out of or in relation to the use of this Inductive Sense Shield, even if Renesas or its affiliates have been advised of the possibility of such damages.

Renesas has used reasonable care in preparing the information included in this document, but Renesas does not warrant that such information is error free nor does Renesas guarantee an exact match for every application or parameter to part numbers designated by other vendors listed herein. The information provided in this document is intended solely to enable the use of Renesas products. No express or implied license to any intellectual property right is granted by this document or in connection with the sale of Renesas products. Renesas reserves the right to make changes to specifications and product descriptions at any time without notice. Renesas assumes no liability for any damages incurred by you resulting from errors in or omissions from the information included herein. Renesas cannot verify, and assumes no liability for, the accuracy of information available on another company's website.

Precautions

This Evaluation Kit is only intended for use in a laboratory environment under ambient temperature and humidity conditions. A safe separation distance should be used between this and any sensitive equipment. Its use outside the laboratory, classroom, study area, or similar such area invalidates conformity with the protection requirements of the Electromagnetic Compatibility Directive and could lead to prosecution.

The product generates, uses, and can radiate radio frequency energy and may cause harmful interference to radio communications. There is no guarantee that interference will not occur in a particular installation. If this equipment causes harmful interference to radio or television reception, which can be determined by turning the equipment off or on, you are encouraged to try to correct the interference by one or more of the following measures:

- Ensure attached cables do not lie across the equipment.
- Reorient the receiving antenna.
- Increase the distance between the equipment and the receiver.
- Connect the equipment into an outlet on a circuit different from that which the receiver is connected.
- Power down the equipment when not in use.
- Consult the dealer or an experienced radio/TV technician for help.

Note: It is recommended that wherever possible shielded interface cables are used.

The product is potentially susceptible to certain EMC phenomena. To mitigate against them it is recommended that the following measures be undertaken:

- The user is advised that mobile phones should not be used within 10 m of the product when in use.
- The user is advised to take ESD precautions when handling the equipment.

The Evaluation Kit does not represent an ideal reference design for an end product and does not fulfill the regulatory standards for an end product.

Renesas RL78 Family

Inductive Proximity Sensor Shield

Contents

1.	Introduction	5
1.1	Features	5
1.2	Tools and Software Versions required	5
2.	Resource Constraints and Usage	6
2.1	Memory resources.....	6
2.2	Timing constraints & CPU load.....	6
3.	Physical Structure.....	8
3.1	Structure.....	8
3.2	Hardware block diagram	8
4.	Software Layer	9
5.	Context Management	11
5.1	System initialization.....	11
5.2	Interrupts	12
6.	Mechanism	13
6.1	Differential Synchronization.....	13
6.2	System State Model	16
6.3	Low power mode	17
6.4	Rotation sensor	17
7.	Peripheral configuration	21
7.1	Used stack.....	21
7.2	Clock tree	22
7.3	BSP	23
7.4	Port function/ Pin assignments.....	24
7.4.1	Port 0 setup.....	25
7.4.2	Port 1 setup.....	25
7.4.3	Port 2 setup.....	25
7.4.4	Port 3 setup.....	26
7.4.5	Port 4 setup.....	26

7.4.6	Port 5 setup.....	26
7.4.7	Port 6 setup.....	26
7.4.8	Port 7 setup.....	27
7.4.9	Port 12 setup.....	27
7.4.10	Port 13 setup.....	27
7.4.11	Port 14 setup.....	27
7.5	Logic and Event link controller.....	28
7.6	Timers.....	30
7.6.1	Measurement period.....	30
7.6.2	Measurement point.....	30
7.6.3	Reference excitation timer.....	31
7.6.4	Sensor excitation timer.....	32
7.7	Comparators.....	33
8.	System configuration.....	34
8.1	External sensors groups.....	34
8.2	Diagnostic services.....	35
8.2.1	Single byte commands.....	35
8.2.2	Write commands.....	35
8.2.3	Read commands.....	35
8.2.4	Real Term example.....	36
8.2.5	Command ID table.....	38
9.	Hardware.....	40
9.1	Final Product.....	40
9.2	Schematic.....	42
9.2.1	Main PCB Schematic Components.....	42
9.2.2	Rotation PCB schematic components.....	47
10.	Component interface.....	48
11.	Website and Support.....	50
	Revision History.....	51

Figures

Figure 1. Complete scan sequence.....	7
Figure 2. Hardware block diagram.....	8
Figure 3. Software layer model.....	9
Figure 4. Application layer diagram.....	9
Figure 5. Hardware Layer Diagram.....	10
Figure 6. Activity diagram.....	11
Figure 7. Working principle.....	13
Figure 8. Excitation pulse – phase shift through one-shot pulse output.....	14
Figure 9. Measurement mechanism.....	15
Figure 10. Flow chart of main application.....	16
Figure 11. Low power mode mechanism.....	17
Figure 12. Stack tree.....	21
Figure 13. Clock tree.....	22
Figure 14. BSP configuration.....	23
Figure 15. Pins assignment.....	24
Figure 16. Block diagram of ELCL.....	28
Figure 17. ELC output destination configuration.....	29
Figure 18. Interval Timer configuration.....	30
Figure 19. TAU0 configuration.....	30
Figure 20. TAU02 and TAU03 configuration.....	31
Figure 21. TAU04 and TAU05 configuration.....	32
Figure 22. Comparator configuration.....	33
Figure 23. Real Term Write.....	36
Figure 24. Real Term Read.....	37
Figure 25. Evaluation board - top view.....	40
Figure 26. Header & Arduino connectors.....	42
Figure 27. PMOD connectors.....	42
Figure 28. Supply options (+3V3 coin cell & PMOD supply switch).....	42
Figure 29. Rotation group (excitation & filters only).....	43
Figure 30. Planar group.....	44
Figure 31. Ferrite group.....	45
Figure 32. External group (filters only).....	45
Figure 33. MUX's.....	46
Figure 34. LEDs.....	46
Figure 35. Rotation coils.....	47

Tables

Table 1. CPU Load as a function of scan time	7
Table 2. Interrupt table	12
Table 3. ELCL selections.....	28
Table 4. Command Table	38
Table 5. Start Module Interface	48
Table 6. Application Module Interface	48
Table 7. Diagnostic Module Interface	48
Table 8. ELCL Module Interface	48
Table 9. TAU Module Interface.....	49

1. Introduction

This document provides detailed information about the RL78/G23 Inductive Sensor system and how the functionality was implemented. The entire system is composed of the Inductive Proximity Sensor shield & the RL78/G23 64p FPB. The IDE used to develop the software is e² studio, installed with the RL78 family tools, which includes the peripheral/device configuration tool (smart configurator) and the all associated compilers.

1.1 Features

- Rotational sensor with indicating LEDs.
- 2 x independent planar coils for buttons.
- 2 x independent ferrite cored coils for buttons.
- Connector for external coils
- 2 x PMOD connectors (Type 2A- expanded SPI and Type 4A- expanded UART) with additional configurable resistor bank to convert any of these into I²C.
- Low power mode
- UART services for system configuration
- Multiple power supplies – +3V3 coin cell, +5V micro-USB or +12V DC barrel connector.

1.2 Tools and Software Versions required

- [RL78/G23 64p FPB](#)
- [Renesas e² studio Integrated Solution Development Environment \(ISDE\)](#) (minimum v2020-10)

Serial terminal software for diagnostics e.g., Real Term.

2. Resource Constraints and Usage

2.1 Memory resources

The chosen microcontroller - R7F100GLG2D includes:

- 128 KB ROM (Code flash)
- 8 KB Data Flash
- 16 KB RAM

The LLVM toolchain, version 10.0.0.202104, has been used in the development of this project. Optimization level is -O0 (None). The resource consumption is as follows:

- ROM (Code Flash): 19,786 Bytes
- Data Flash: 53 Bytes
- RAM: 262 Bytes
- Estimated Stack size: 100 Bytes

2.2 Timing constraints & CPU load

The high-speed clock is configured at 32MHz using the on-chip high-speed oscillator which is the clock source of the CPU and most other peripherals. The low power timer used to control the scan period uses the external crystal oscillator XT1 with a frequency of 32.768kHz.

Timing constraints are related to:

- **UART communication:** the baud rate of the Serial Terminal software needs to be set to 15625, for the communication to work properly.
- **Sensor scan sequence:** default time interval for a full scan is 125ms.

During this time, the microcontroller starts a scan sequence as follows:

- An excitation pulse, based on two timer channels in master-slave configuration to provide a one-shot pulse output mode, defined by the pulse delay and the excitation pulse width.
- Measuring point, the delay between the excitation pulse and the reading of the comparators.
- Algorithm delay, time taken to read data from comparator registers, reset timer values and respond to read data values.

The sequence works in parallel for sensors and references of the same group, using different timers and timing values. This reduces CPU load; a summary of coil group timings & CPU loads can be found below in Table 1.

Sensor groups	Type of sensor	Default excitation delay [ns]	Default excitation width [ns]	Default measurement point delay [us]	Total scan sequence [us]	Delay percent of a full scan [%]
Rotation	Sensor	312	156	3	10.85	0.00868
	Reference	63	94			
Planar	Sensor	312	156	3	9.3	0.00744
	Reference	63	94			
Ferrite	Sensor	250	94	3	9.8	0.00784
	Reference	63	94			

Table 1. CPU Load as a function of scan time

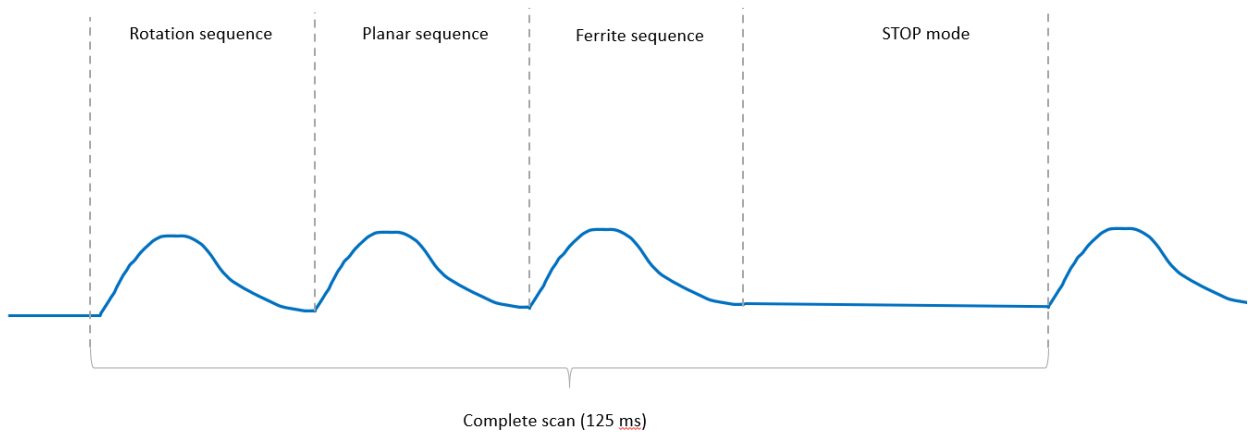

Figure 1. Complete scan sequence

Once all group scans are completed, STOP mode is activated until the interval timer interrupt is activated and another set of measurements begins.

The stop mode interval is 124.97005ms, which represents 99.97604% of the entire sequence.

3. Physical Structure

3.1 Structure

The Renesas inductive proximity sensing solution is composed of:

- 1 x RL78/G23 64p FPB
- 1 x Inductive Proximity Sensor Shield

3.2 Hardware block diagram

Figure 2 shows the hardware blocks used in the RL78/G23 inductive proximity sensing solution. The RL78/G23 64p FPB generates excitation pulses, detects the presence of the conductive targets above the sense coils using internal comparators and establishes the USB-UART communications.

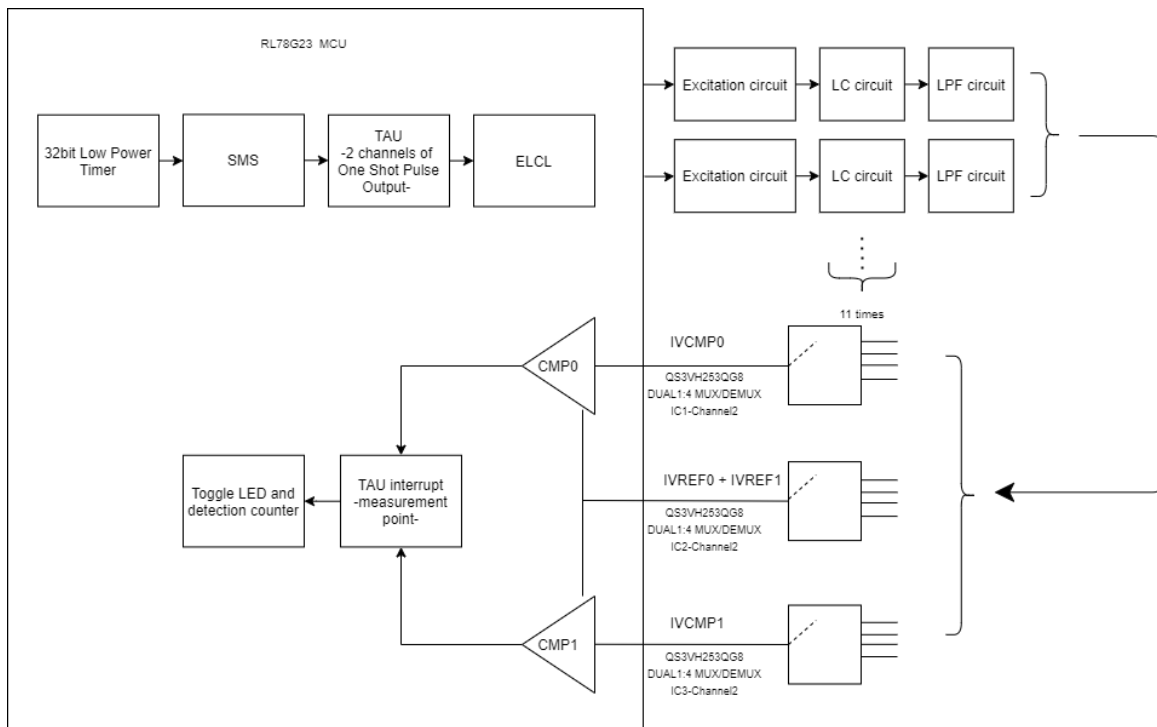

Figure 2. Hardware block diagram

4. Software Layer

The following picture represents the software model.

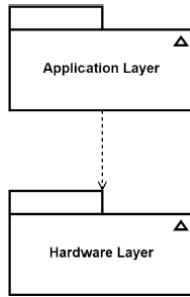

Figure 3. Software layer model

The **Application layer** implements the functionality of the Renesas inductive proximity sensing solution sequencer which contains:

- Application process (APP): this module is responsible to update the hardware components for the sensors group selection.
- Timing configuration (TIMER): this module is responsible for cycle management of the measurement.
- Diagnosis configuration (DIAG): this module is responsible for the system configuration and calibration.
- Control Data Flash (CDF): this module is responsible for the flash data management.

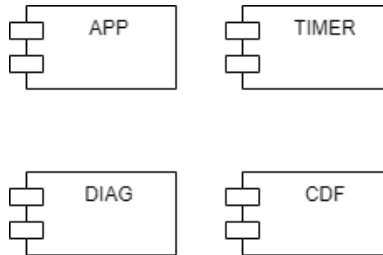

Figure 4. Application layer diagram

The **Hardware layer** is responsible for interfacing the MCU hardware components/peripherals of the system with the rest of the application. The majority of the content in this layer is provided by the drivers for the RL78/G23, which are generated and configured in e² studio through the smart configurator tool.

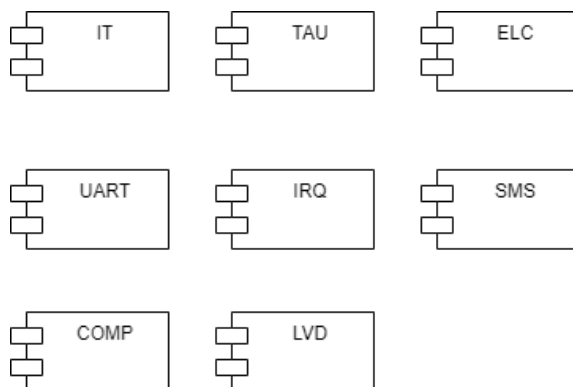

Figure 5. Hardware Layer Diagram

5. Context Management

5.1 System initialization

The start-up sequence after power-on reset is presented in Figure 6 below.

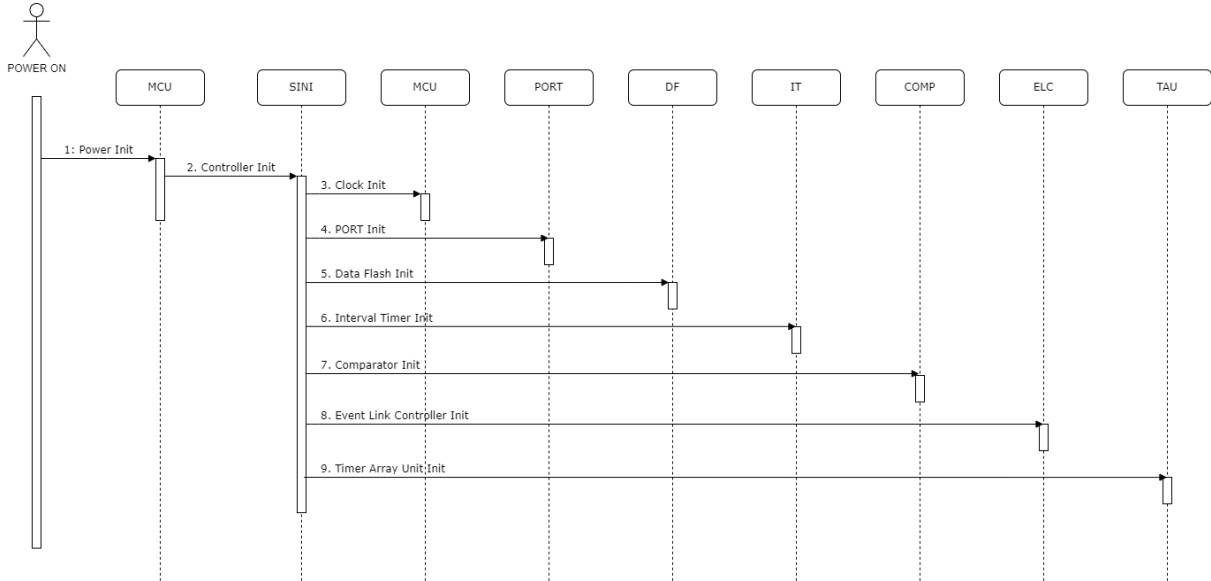

Figure 6. Activity diagram

The first step after power-on reset is the basic controller initialization. Next is the initialization of the clock tree and microcontroller hardware components used for the application algorithm. Finally the data flash is initialized and prepared for reading.

5.2 Interrupts

Table 2 below presents interrupts used in the solution.

Interrupt	Priority	Callback	Description
Interval Timer interrupt	Level 1	R_Config_ITL000_ITL001_Callback_Shared_Interrupt()	Cyclic measurement trigger
TAU0 interrupt	High	r_Config_TAU0_0_interrupt()	Timer overflow interrupt used to set the measurement point
UART reception overrun interrupt	Low	r_Config_UART0_callback_softwareoverrun()	The reception end interrupt when the package length is undefined, used to read the type of command and prepare the reception for the next message bytes.
UART reception end interrupt	Low	r_Config_UART0_callback_receiveend()	The reception end interrupt when the package length is defined, used for command ID and data messages.
UART error interrupt	Low	r_Config_UART0_callback_error()	The reception error interrupt used for protection of data messages.

Table 2. Interrupt table

NOTE: The UART reception interrupts are used in 2 modes:

- **In normal mode:** based on the high-speed main clock and interrupt enable flag.
- **In snooze mode:** when the STOP mode is enabled between cyclic measurements, the UART module is configured in snooze mode to wake up if a reception interrupt is detected.

6. Mechanism

The following section outlines the mechanisms utilized in the RL78/G23 64p FPB Inductive Proximity Sensing solutions implementation.

6.1 Differential Synchronization

The working principle is based on LC tank circuit oscillation. To detect conductive target presence over a sense coil, another coil is required as reference. This reference coil is controlled and there is no conductive target near it so we can compare this controlled (undamped) coil to the sense coil. The measurement starts by exciting (charging) both reference and sense LC circuits. The circuits are excited through transistor drive circuits controlled by pulses generated by the RL78/G23 MCU. After the coils have been excited, they will start to oscillate. The oscillation is then filtered, resulting in an oscillation envelope. At the end of the process the two envelopes are selected through external multiplexers (used to support the large range of coil groups in evaluation) and fed into the built-in RL78/G23 comparators whereby the sense LC circuits damped condition can be tested against the reference LC circuit.

A conductive target can be detected as the sense LC circuits oscillation becomes damped and the signal input to the comparator becomes lower than that of the reference LC circuit at a pre-determined point in time.

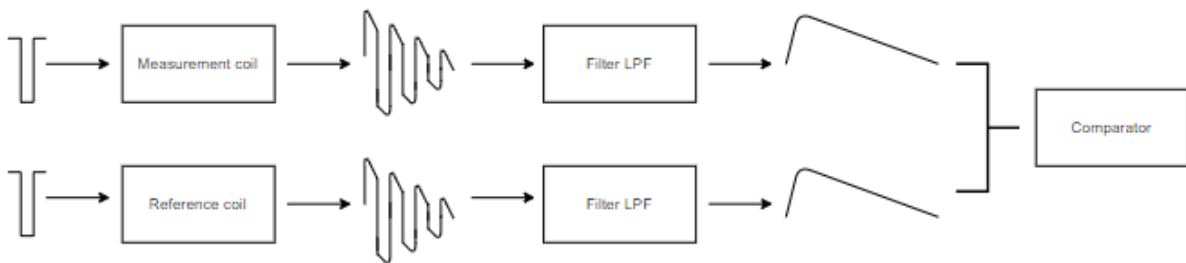

Figure 7. Working principle

For the ease of understanding, the excitation mechanism will be described for only one LC circuit. But it is used/performed for all LC circuits.

In this case, two pairs of timers are used. They are configured as One-Shot Pulse Output, one for the sense circuit and the other for the reference circuit. With configurable pulse width (slave timer) and pulse start delay (master). The custom configuration allows high resolution calibration through phase shifting excitation pulses and varying excitation pulse widths.

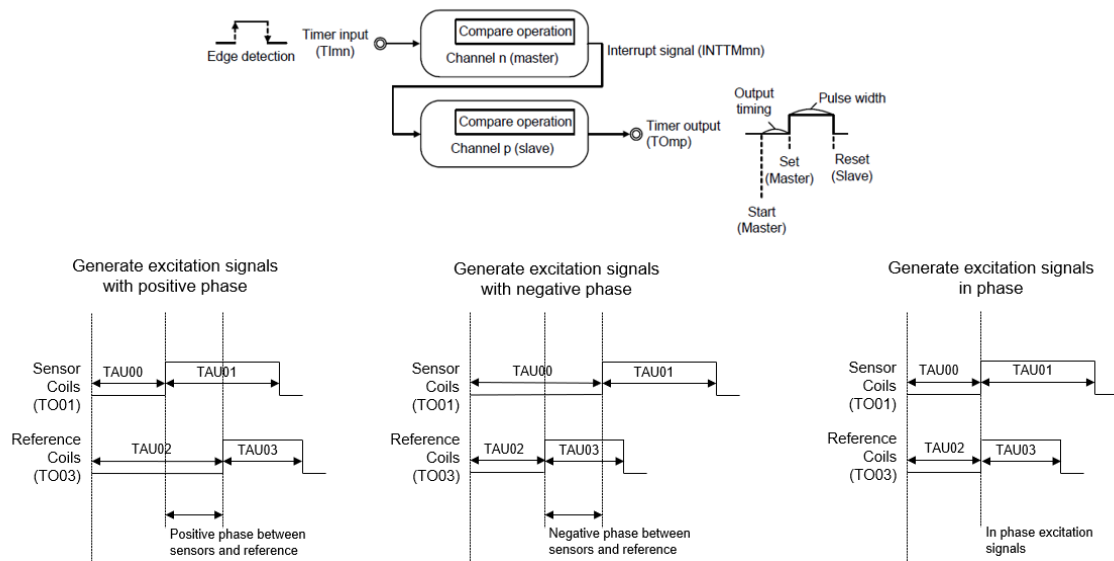

Figure 8. Excitation pulse – phase shift through one-shot pulse output

Timer channel 5 of the TAU is configured in interval timer mode and is used to time the delay between the pulse trigger and the comparator measurement point i.e., when the output envelopes are compared.

For a lower power consumption only two pairs of excitation timers are used for all group of sensors, which are switched using the internal event link controller module and controlled by three input pins (P20, P21, P22).

The metal object detection over the coils is based on the comparators results as follows:

- A measurement of a coils group is started.
- When the measurement point timer for the coils is triggered, the callback function is called. The measured data is processed, based on the comparator result.
- Based on the actual result, the correlated LED for each sensor will be enabled and a variable will be incremented if the object is over it.

Only after the data processing ends, is the next coil group in the measurement manager is excited. This process repeats until all coil groups are excited and processed. This entire measurement cycle is triggered cyclically by an interval timer (32-bit low power timer). The default period for this cycle is 125ms, but it can be changed using diagnostic services.

For the rotational sensor, the same principle is used. The difference is that, while on one scan, two of the three available coils are excited to determine the current **position** of the metal disc (also using the reference coil + two on board comparators) there is also a third coil which can be enabled/pulsed and compared against the reference coil on a separate scan, and this is used for disc **presence** detection.

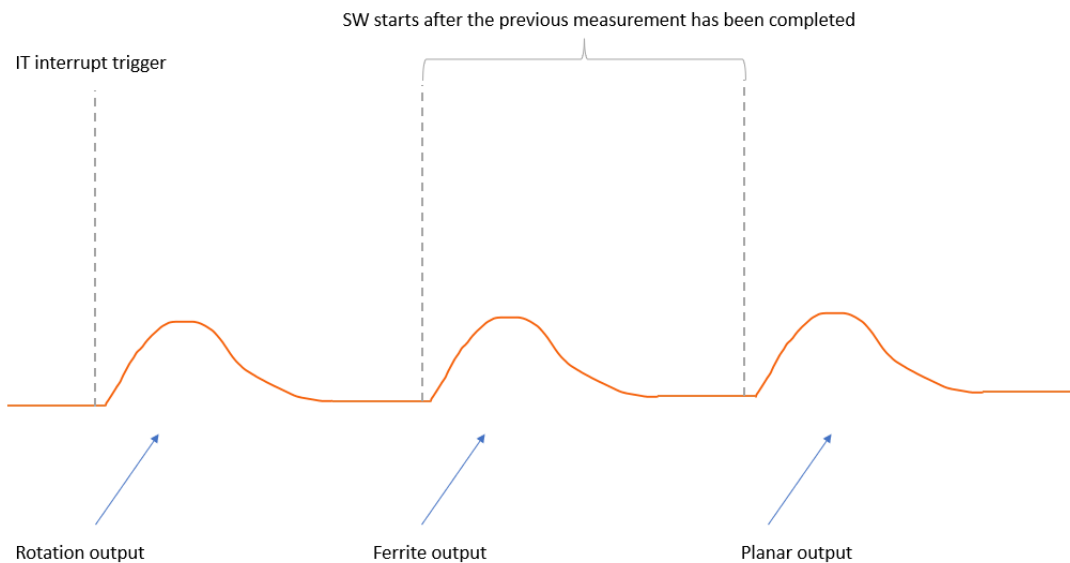

Figure 9. Measurement mechanism

6.2 System State Model

The Sequence Diagram below presents the measurement logic of the RL78/G23 Inductive Sensor. A disc presence check can be added to the cyclic measurement for the third rotation sensor, for safety rotation reading, with the same measurement logic as the rest of group sensors. The enable/disable control is available via UART commands in the diagnostic services.

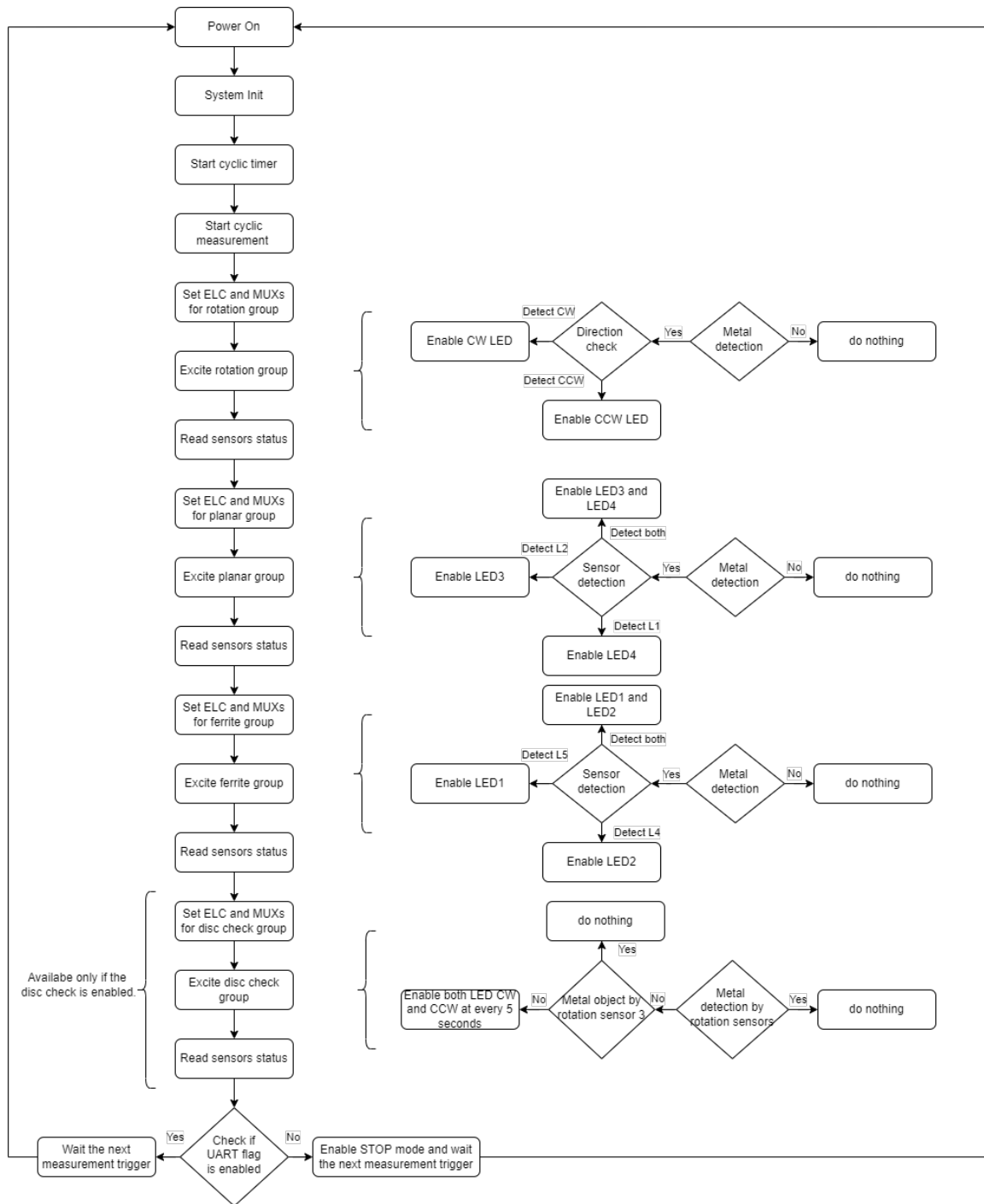

Figure 10. Flow chart of main application

6.3 Low power mode

An important requirement of the inductive proximity sensing solution is low power consumption. For this, all unused pins are configured as outputs to remove the through currents associated with input buffers. Between measurement intervals the MCU enters stop mode which disables all internal oscillators and clocks except for the sub-system clock, for which the source oscillator is XT1 and is supplied to the scan interval timer (32-bit low power timer). Finally, if the device receives a UART packet while in the stop mode, snooze mode is activated to check the validity of the UART packet (without waking the CPU) before subsequently waking the device up to provide diagnostic services.

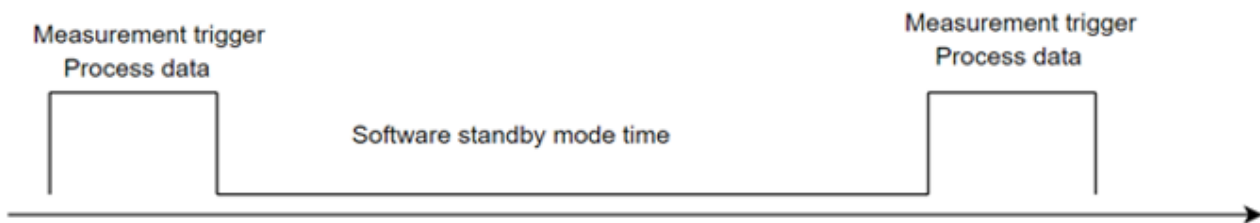
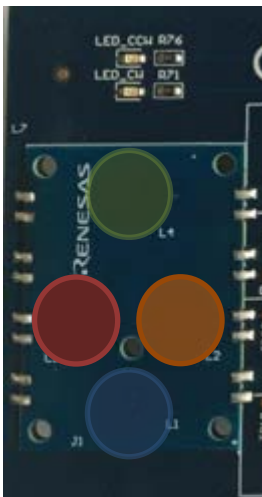
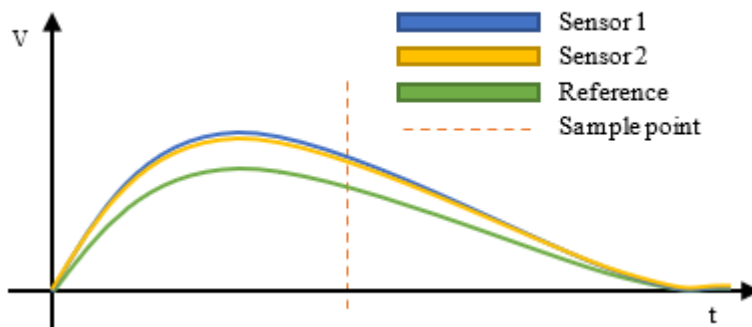
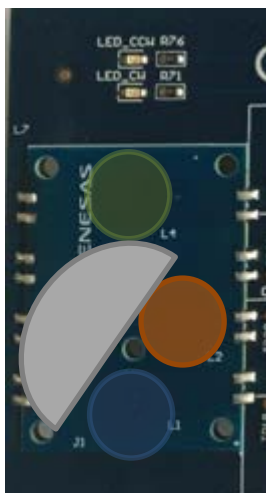

Figure 11. Low power mode mechanism

6.4 Rotation sensor



- Green** – Rotation reference
- Blue** – Rotation sensor 1 – disc rotation
- Yellow** – Rotation sensor 2 – disc rotation
- Red** – Rotation sensor 3 – disc presence (blink rotation LEDs at every 5 seconds if disc is not present)



The metal disc does not cover the position coils (sensors 1 & 2). Their signals are above the reference level.

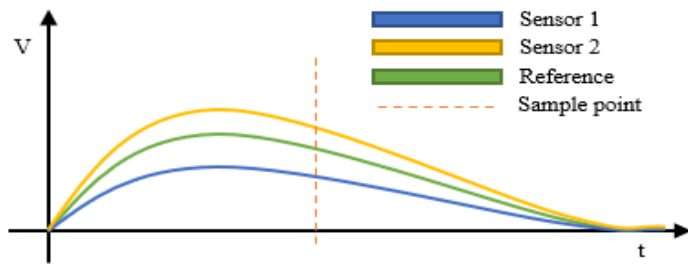
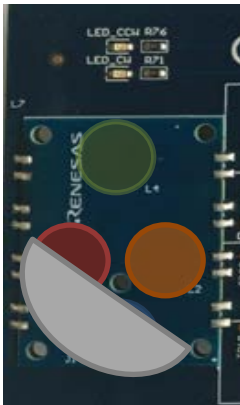

After a rotation of 90 degrees, the disk covers only coil 1, its signal level is below the reference and the signal of the second coil is above the reference.

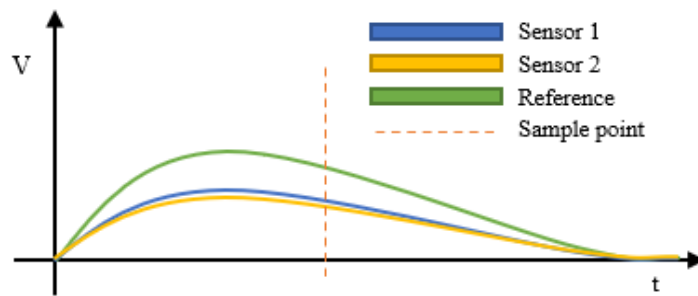
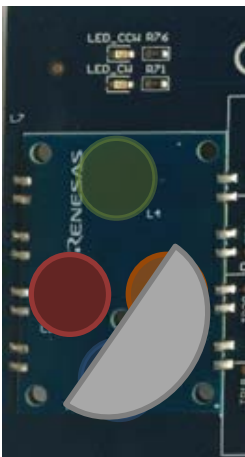

After a rotation of 90 degrees, the disk covers both coils, the signals levels are below the reference.

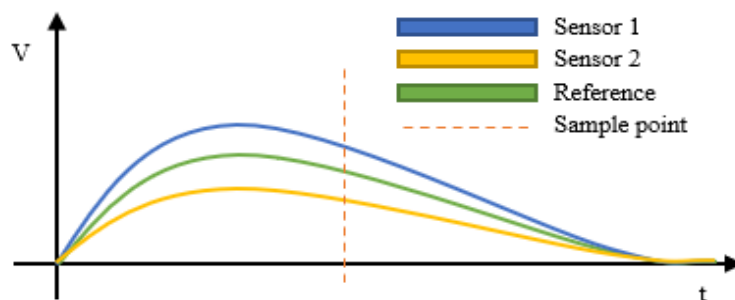
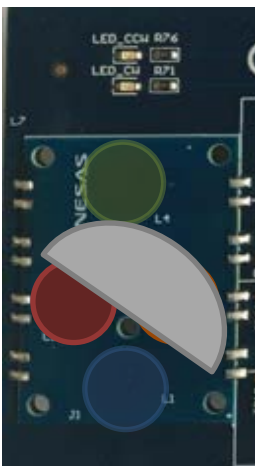

After a rotation of 90 degrees, the disk covers only coil 2, its signal level is below the reference and the signal of the first coil is above the reference.

The quadrature algorithm provisions no minimum rotation speed limitation.

7. Peripheral configuration

The build-in e² studio configurator was used to configure the peripheral and pins state as follows:

7.1 Used stack

The following stack tree structure is used:

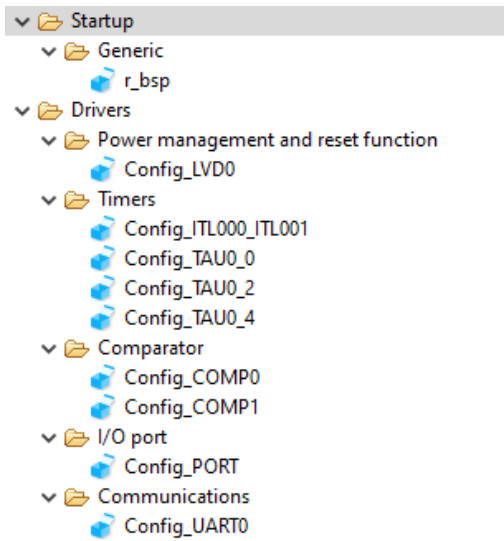

Figure 12. Stack tree

7.2 Clock tree

For this configuration clock sources are used:

- 32 MHz High-speed on-chip oscillator
- 32.768 kHz XT1 external oscillator used for the 32-bit low power interval timer in stop mode.

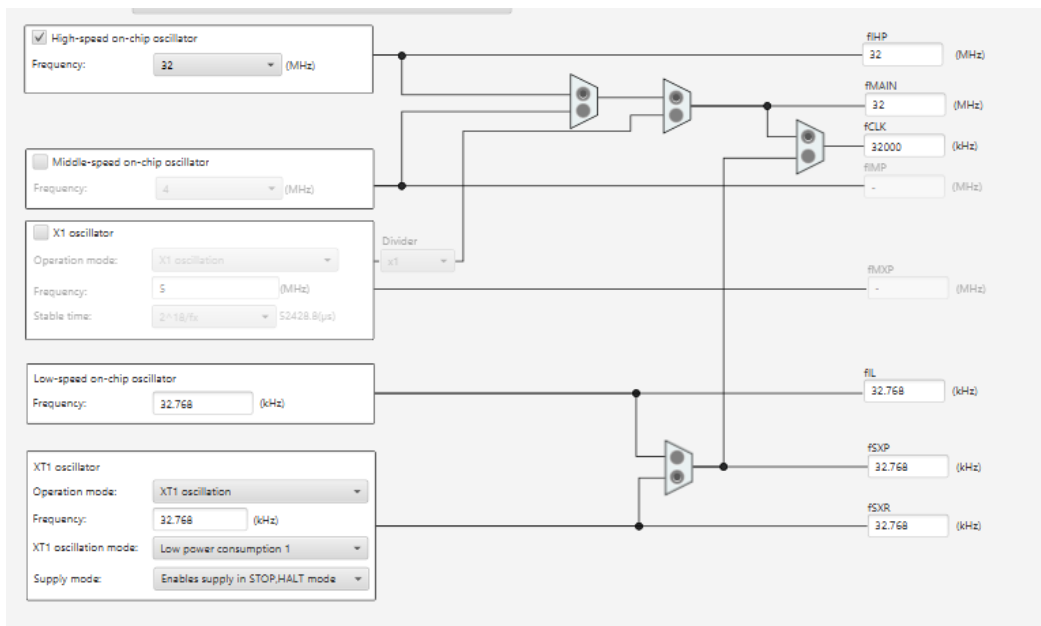

Figure 13. Clock tree

7.3 BSP

The Board Support Package configuration is presented below:

Property	Value
▼  Configurations	
# Start up select	Enable (use BSP startup)
# Control of invalid memory access detection	Disable
# RAM guard space(GRAM0-1)	Disabled
# Guard of control registers of port function(GPORT)	Disabled
# Guard of registers of interrupt function(GINT)	Disabled
# Guard of control registers of clock control function	Disabled
# Data flash access control(DFLEN)	Enables
# Initialization of peripheral functions by Code Generator	Enable
# API functions disable	Enable
# Parameter check enable	Enable
# Setting for starting the high-speed on-chip oscillator	High-speed
# Enable user warm start callback (PRE)	Unused
# User warm start callback function name (PRE)	my_sw_warmstart_prec_function
# Enable user warm start callback (POST)	Unused
# User warm start callback function name (POST)	my_sw_warmstart_postc_function
# Watchdog Timer refresh enable	Unused
# Watchdog Timer initialize user function name	my_sw_wdt_refresh_init_function
# Watchdog Timer setting user function name	my_sw_wdt_refresh_setting_function

Figure 14. BSP configuration

7.4 Port function/ Pin assignments

The next image provides the graphical view of pins assignment:

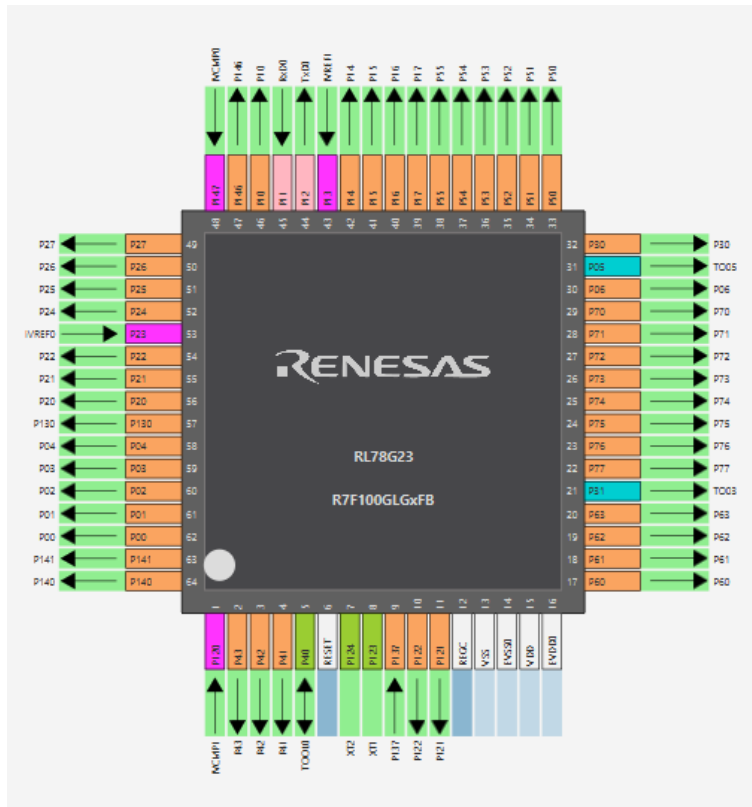

Figure 15. Pins assignment

7.4.1 Port 0 setup

Pin	Pin description/function
P00	SPI CS
P01	ELCL output 0 – excitation for rotation S1 and S2
P02	Unused output pin
P03	I2C SDA channel 2
P04	I2C SCL channel 2
P05	Sensor Timer – slave output
P06	Unused output pin

7.4.2 Port 1 setup

Pin	Pin description/function
P10	ELCL output 0 – excitation for ferrite S1 and S2 and external sensors
P11	RX0
P12	TX0
P13	Input – comparator 1 reference
P14	ELC output 4 – excitation for rotation S3
P15	ELC output 5 – excitation for rotation reference
P16	ELC output 6 – excitation for planar reference
P17	ELC output 7 – excitation for ferrite and external reference

7.4.3 Port 2 setup

Pin	Pin description/function
P20	Input ELC channels selection
P21	Input ELC channels selection
P22	Input ELC channels selection
P23	Input – comparator 0 reference
P24	Output LED 4 (Planar sensor 1)
P25	Output LED 3 (Planar sensor 2)
P26	Output LED 2 (Ferrite sensor 1)
P27	Output LED 1 (Ferrite sensor 2)

7.4.4 Port 3 setup

Pin	Pin description/function
P30	Output pulse used to check with the scope the measurement point trigger (also it is configured as I2C SCL channel1 – <i>not used</i>)
P31	Reference Timer – slave output

7.4.5 Port 4 setup

Pin	Pin description/function
P40	TOOL0 pin
P41	Output selection 1 MUX IC 2
P42	PMOD reset channel 1 (for UART and I2C ch2)
P43	UART RTS

7.4.6 Port 5 setup

Pin	Pin description/function
P50	I2C SDA channel 1
P51	ELC output 1 – excitation for planar S1 and S2
P52	Output enable A MUX IC 1
P53	Output selection 1 MUX IC 1
P54	Output selection 0 MUX IC 1
P55	Output enable B MUX IC 1

7.4.7 Port 6 setup

Pin	Pin description/function
P60	Unused output pin
P61	Unused output pin
P62	Unused output pin
P63	Unused output pin

7.4.8 Port 7 setup

Pin	Pin description/function
P70	SPI SCLK
P71	SPI MOSI
P72	SPI MISO
P73	Unused output pin
P74	Output enable A MUX IC 2
P75	Output enable B MUX IC 2
P76	Output selection 0 MUX IC 2
P77	Unused output pin

7.4.9 Port 12 setup

Pin	Pin description/function
P120	Input – comparator 1 channel
P121	UART CTS
P122	UART Interrupt
P123	External low-speed oscillator
P124	External low-speed oscillator

7.4.10 Port 13 setup

Pin	Pin description/function
P130	Output LED CW
P137	Unused input pin

7.4.11 Port 14 setup

Pin	Pin description/function
P140	PMOD reset channel 1 (for SPI and I2C ch1)
P141	PMOD Interrupt channel 1 (for SPI and I2C ch1)
P146	Output LED CCW
P147	Input comparator 0 channel

In the current configuration the SPI and I2C channels 1 & 2 are not implemented in the software project but are available in hardware via the PMODs.

7.5 Logic and Event link controller

The logic and event link controller (ELCL) connects signals' output through peripheral functions to other specified peripheral functions using internal logic cell blocks, allowing direct communication between peripheral functions without CPU intervention.

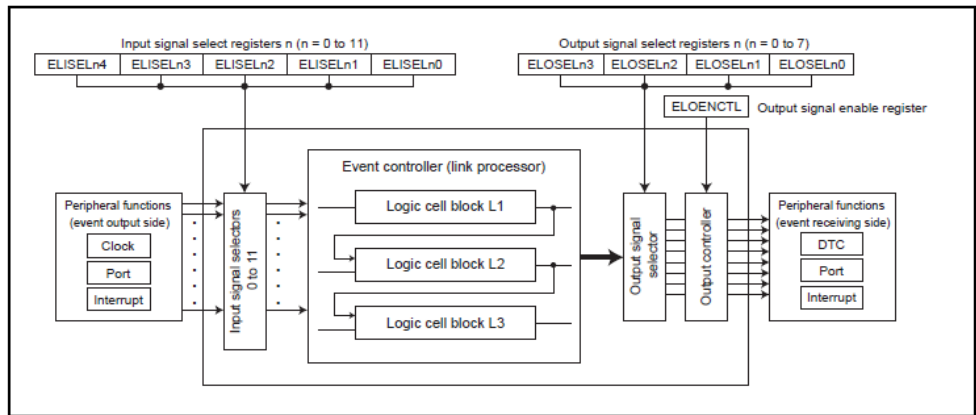

Figure 16. Block diagram of ELCL

The ELCL configuration between one-shot pulse timer output signals and the pins the signals are output to is configured in the initialization sequence. Channel toggling is available using the signal levels on three GPIOs, configured to be input to the ELCL follows (see Chapter 7.4 for ELCL input and output pins):

Pin	Select rotation group	Select planar group	Select ferrite/external group
P20	High	High	Low
P21	High	Low	High
P22	Low	High	High

Table 3. ELCL selections

The ELC output destination is available in the next image, where:

- RS1 + RS2: rotation sensor 1 and sensor 2
- PS1 + PS2: planar sensor 1 and sensor 2
- FS1 + FS2 + ES: ferrite sensor 1, ferrite sensor 2 and external sensor
- RS3: rotation sensor 3
- RR: rotation reference
- PR: planar reference
- FR + ER: ferrite reference and external reference

Register and Bit Name	Event-Receiving Peripheral Function					
	Destination 1	Destination 2	Destination 3	Destination 4	Destination 5	Destination 6
ELOENCTL. ELOENCTL0	Output pin (P50)	Output pin (P01) RS1 + RS2	Event link interrupt (INTELCL) ^{Note 3}	Output pin (P10) FS1 + FS2 + ES	—	—
ELOENCTL. ELOENCTL1	Output pin (P51) PS1 + PS2	Output pin (P60)	DTC activation trigger ^{Note 3}	Output pin (P11)	—	—
ELOENCTL. ELOENCTL2	Serial clock input to SAU0 channel 0	Output pin (P61)	SMS activation trigger ^{Note 3}	Output pin (P12)	—	—
ELOENCTL. ELOENCTL3	Serial clock input to SAU0 channel 1	Timer input to TAU0 channel 0 ^{Note 1}	—	Output pin (P13)	—	—
ELOENCTL. ELOENCTL4	Receive data input to SAU0 channel 0	Timer input to TAU0 channel 1 ^{Note 1}	—	Output pin (P14) RS3	—	—
ELOENCTL. ELOENCTL5	Receive data input to SAU0 channel 1	—	—	Output pin (P15) RR	Hardware trigger for A/D converter ^{Note 3}	Clock input to UARTA (UARTA0, UARTA1) ^{Note 2}
ELOENCTL. ELOENCTL6	—	Timer input to TAU0 channel 5 ^{Note 1}	—	Output pin (P16) PR	Hardware trigger for D/A converter 0 ^{Note 3}	Hardware trigger for CTSU ^{Note 3}
ELOENCTL. ELOENCTL7	—	—	—	Output pin (P17) FR + ER	Hardware trigger for D/A converter 1 ^{Note 3}	TML32 operating clock, capture trigger ^{Note 3}

Figure 17. ELC output destination configuration

7.6 Timers

7.6.1 Measurement period

For the measurement period the 32-bit low power interval timer is used, configured in 16-bit count mode, using the XT1 oscillator as its count source. The default period is 125ms, but this period can be changed using diagnostic services.

Clock setting	
Operation clock (fITL0)	fSXP
Clock source	fITL0 (Clock frequency: 32.768 kHz)
Interval timer setting	
Interval value	125 ms (Actual value: 125)
Interrupt setting	
<input checked="" type="checkbox"/> Detection of compare match/capture completion (INTITL)	
Priority	Level 1

Figure 18. Interval Timer configuration

7.6.2 Measurement point

TAU00 is used in interval timer mode to time the delay between triggering a pulse output and comparing the sensor and reference circuits output signals using the comparators. The period is customized for each coil group and can be changed by diagnostic services.

Clock setting	
Operation clock	CK00
Clock source	fCLK (Clock frequency: 32000 kHz)
Interval timer setting	
Interval value (16 bits)	3 μs (Actual value: 3)
<input type="checkbox"/> Generates INTTM00 when counting is started	
Interrupt setting	
<input checked="" type="checkbox"/> End of timer channel 0 count, generate an interrupt (INTTM00)	
Priority	High

Figure 19. TAU0 configuration

7.6.3 Reference excitation timer

TAU02 and TAU03 are used in one-shot pulse output configuration, to generate excitation pulses for the reference LC circuits. The master channel (TAU02) controls the delay between starting the one-shot pulse timer and the pulse being asserted. The slave channel (TAU03) controls the pulse width timing.

Clock setting	
Operation clock	CK00
Clock source	fCLK (Clock frequency: 32000 kHz)
One-shot trigger setting	
<input checked="" type="radio"/> Software trigger	<input type="radio"/> External trigger
<input type="checkbox"/> Enable using noise filter of TI02 pin input signal	
TI02 input edge selection	Falling edge
One-shot delay time setting	
Delay time	100 ns (Actual value: 94)
Interrupt setting	
<input type="checkbox"/> End of timer channel 2 count, generate an interrupt (INTTM02)	
Priority	Low
One-shot slave select setting	
<input checked="" type="radio"/> Channel 3 slave	<input type="radio"/> Channel 4 slave
<input type="radio"/> Channel 5 slave	<input type="radio"/> Channel 6 slave
<input type="radio"/> Channel 7 slave	
When multiple master channels are used, the slave channels cannot be set across master channels.	
One-shot slave setting	
Slave3	
One-shot pulse width setting	
Pulse width	100 ns (Actual value: 94)
Output setting	
Initial output value	0
Output level	Active-low
Interrupt setting	
<input type="checkbox"/> End of timer channel 3 count, generate an interrupt (INTTM03)	
Priority	Low

Figure 20. TAU02 and TAU03 configuration

7.6.4 Sensor excitation timer

TAU04 and TAU05 are used in one-shot pulse output configuration, to generate excitation pulses for the sense LC circuits. The master channel (TAU04) controls the delay between starting the one-shot pulse timer and the pulse being asserted. The slave channel (TAU05) controls the pulse width timing.

Clock setting	
Operation clock	CK00
Clock source	fCLK (Clock frequency: 32000 kHz)
One-shot trigger setting	
<input checked="" type="radio"/> Software trigger <input type="radio"/> External trigger	
<input type="checkbox"/> Enable using noise filter of TI04 pin input signal	
TI04 input edge selection	Falling edge
One-shot delay time setting	
Delay time	100 ns (Actual value: 94)
Interrupt setting	
<input type="checkbox"/> End of timer channel 4 count, generate an interrupt (INTTM04)	
Priority	Low
One-shot slave select setting	
<input checked="" type="radio"/> Channel 5 slave <input type="radio"/> Channel 6 slave <input type="radio"/> Channel 7 slave	
<small>When multiple master channels are used, the slave channels cannot be set across master channels.</small>	
One-shot slave setting	
Slave5	
One-shot pulse width setting	
Pulse width	100 ns (Actual value: 94)
Output setting	
Initial output value	1
Output level	Active-low
Interrupt setting	
<input type="checkbox"/> End of timer channel 5 count, generate an interrupt (INTTM05)	
Priority	Low

Figure 21. TAU04 and TAU05 configuration

7.7 Comparators

The on-chip comparators are used to compare the analog envelopes of the reference and sense circuits at a determined point in time. The comparator result is read directly from the COMPMDR register, without comparator interrupt. The RL78/G23 MCU has two independent on-chip comparators, which provision for to comparing, in parallel, two measurement sensors against a single reference.

Speed setting		
<input type="radio"/> Low speed	<input checked="" type="radio"/> High speed	
Reference voltage setting		
Reference voltage	IVREF0	
Voltage range	0 ~ VDD-1.4V	
Edge setting		
<input type="radio"/> Rising edge	<input checked="" type="radio"/> Falling edge	<input type="radio"/> Both edges
Digital filter setting		
<input type="checkbox"/> Enable digital filter		
Sampling clock	fCLK	(Clock frequency: 32000 kHz)
Output setting		
<input type="checkbox"/> Enable output (VCOUT0)		
Output polarity	Normal	
Interrupt setting		
<input type="checkbox"/> Use comparator 0 interrupt (INTCMP0)		
Priority	Low	

Figure 22. Comparator configuration

8. System configuration

8.1 External sensors groups

The inductive proximity sense project is configured to detect conductive targets using three different coil groups on the inductive sense shield:

- Rotation group
- Planar group
- Ferrite group

An extra feature of this project is to allow the detection of conductive targets using an external coil group. That is via J10 (which is compatible with the RA2E1 external coil board interface) a PCB housing custom coils can be used to perform inductive proximity sensing. This feature is not enabled by default, in order to enable the scan, one should follow the steps below:

- Use ELCL excitation routing from ferrite group (it is a common one)
- Add MUX selection configuration for output envelope routing in APP layer
- Add selection output group in ELC layer
- Add selection for excitation and data reading in measurement point interrupt.

8.2 Diagnostic services

The system has a diagnostic module implemented through a UART communications interface. Initially the RL78/G23 enters stop mode between scans. Therefore, the device's UART channel is configured to operate in snooze mode on detection of a valid edge on the Rx pin. On detection of this edge, the UART peripheral autonomously receives the data packet and wakes the system up once the packet is finished being received. Once the first byte is received, the device is "active" and will not return to stop mode between scans until the communications is closed with a valid "close" command. The UART configuration is:

- Data: 8-bits
- Parity: none
- Stop: 1-bit
- Baud: 15625 (FTDI supports this, serial terminal software must support custom/non-standard bauds)

8.2.1 Single byte commands

There are three **single byte** commands:

- **0x0A**: Close communications (put device in stop mode between scans).
- **0x09**: Save config to data-flash (saves current timer configurations to data-flash).
- **0x08**: Reset custom values (resets all timer configurations to factory values and saves to data-flash).

8.2.2 Write commands

Write commands take the format:

0x2E	Command ID - <i>MSB</i>	Command ID - <i>LSB</i>	Data - <i>LSB</i>	Data - <i>MSB</i>
-------------	-------------------------	-------------------------	-------------------	-------------------

Where:

- **0x2E** is the command type (write)
- The next two bytes contain the command ID (see command ID table)
- The final two bytes contain the data to write.

Example:

0x2E 0xFF 0x02 0x64 0x00 → set the 100ns (0x64) on planar sensors pulse width.

8.2.3 Read commands

Read commands take the format:

0x22	Command ID - <i>MSB</i>	Command ID - <i>LSB</i>
-------------	-------------------------	-------------------------

Where:

- **0x2E** is the command type (write)
- The next two bytes contain the command ID (see command ID table)

Example:

0x22 0xFF 0x1B → read rotation and button counter (response in ASCII format).

8.2.4 Real Term example

Example **write** with Real Term, commands values are sent in hexadecimal.

- Command: **0x2E 0xFF 0x02 0x64 0x00**

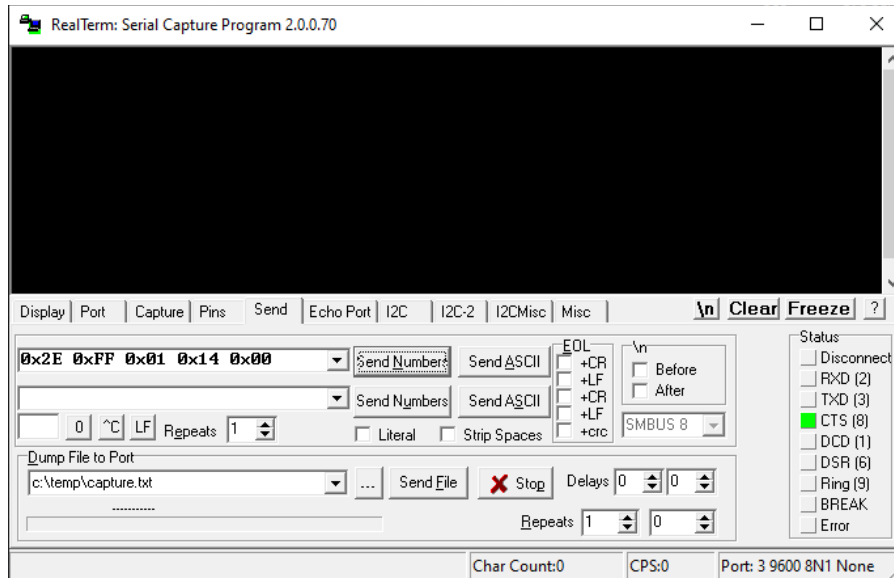

Figure 23. Real Term Write

Example **read** with Real Term, commands values are sent in hexadecimal.

- Command: **0x22 0xFF 0x1B**

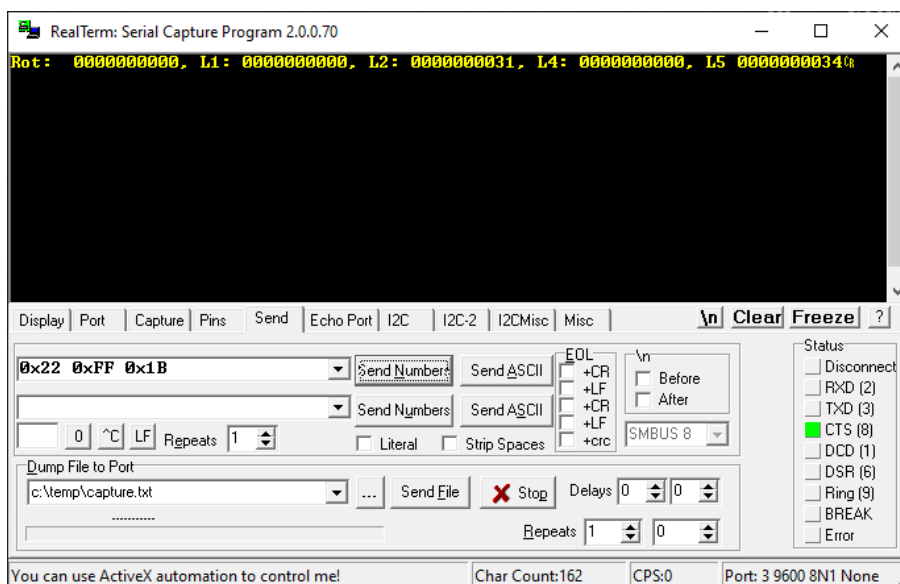

Figure 24. Real Term Read

8.2.5 Command ID table

CMD ID	Command Description	Comments	Default values
0xFF00	<i>Reserved</i>		
0xFF01	Excitation period (ms)	<i>Write only</i>	125 [ms]
0xFF02	Planar sensors pulse width (ns)	<i>Write only</i>	125 [ns]
0xFF03	Planar reference pulse width (ns)	<i>Write only</i>	94 [ns] – min. value
0xFF04	Planar sensors delay (ns)	<i>Write only</i>	281 [ns]
0xFF05	Planar reference delay (ns)	<i>Write only</i>	63 [ns] – min. value
0xFF06	Planar measurement point (us)	<i>Write only</i>	2.53 [us]
0xFF07	Ferrite sensors pulse width (ns)	<i>Write only</i>	94 [ns]
0xFF08	Ferrite reference pulse width (ns)	<i>Write only</i>	94 [ns] – min. value
0xFF09	Ferrite sensors delay (ns)	<i>Write only</i>	281 [ns]
0xFF0A	Ferrite reference delay (ns)	<i>Write only</i>	63 [ns] – min. value
0xFF0B	Ferrite measurement point (us)	<i>Write only</i>	3 [us]
0xFF0C	External sensor pulse width (ns)	<i>Not implemented</i>	
0xFF0D	External reference pulse width (ns)	<i>Not implemented</i>	
0xFF0E	External sensors delay (ns)	<i>Not implemented</i>	
0xFF0F	External reference delay (ns)	<i>Not implemented</i>	
0xFF10	External measurement point (us)	<i>Not implemented</i>	
0xFF11	Rotation sensor pulse width (ns)	<i>Write only</i>	125 [ns]
0xFF12	Rotation reference pulse width (ns)	<i>Write only</i>	94 [ns] – min. value
0xFF13	Rotation sensors delay (ns)	<i>Write only</i>	343 [ns]
0xFF14	Rotation reference delay (ns)	<i>Write only</i>	63 [ns] – min. value
0xFF15	Rotation measurement point (us)	<i>Write only</i>	1.84 [us]
0xFF16	Rotation disc check sensor pulse width (ns)	<i>Write only</i>	125 [ns]
0xFF17	Rotation disc check reference pulse width (ns)	<i>Write only</i>	94 [ns] – min. value
0xFF18	Rotation disc check sensor delay (ns)	<i>Write only</i>	343 [ns]
0xFF19	Rotation disc check reference delay (ns)	<i>Write only</i>	63 [ns] – min. value
0xFF1A	Rotation disc check measurement point (us)	<i>Write only</i>	1.84 [us]
0xFF1B	Data (rotation and buttons counter value)	<i>Read only</i>	0 - disabled
0xFF1C	<i>Reserved</i>		
0xFF1D	Rotation disc check state (enable/disable)	<i>Enable: 0xFFFF</i> <i>Disable: 0x0000</i> <i>Write only</i>	0x0000

Table 4. Command Table

NOTE:

- Minimum delay value for sensors and references = 63 [ns]
- Minimum pulse width value for sensors and references = 94 [ns]

9. Hardware

9.1 Final Product

Figure 25 below shows the inductive proximity sensing shield PCB annotated. This board needs to be connected to the RL78/G23 64p FPB. The inductive proximity sensing shield is comprised of two PCB's:

- Main PCB
- Rotation coils PCB

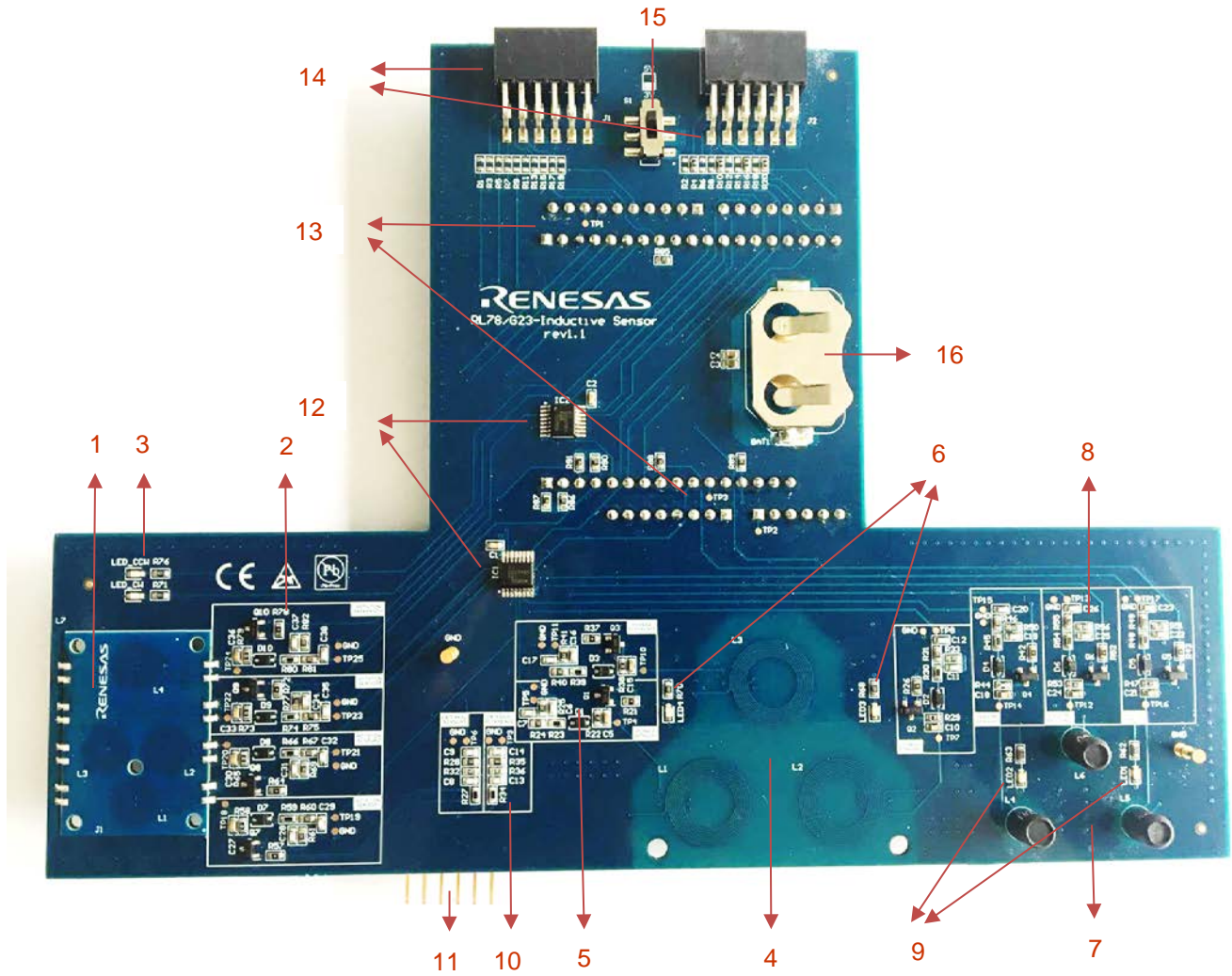

Figure 25. Evaluation board - top view

1. Rotation sensors group (Rotation coils PCB)
2. Rotation circuit
3. Rotation indicating LEDs
4. Planar buttons group
5. Planar buttons circuit
6. Planar buttons indicating LEDs
7. Ferrite buttons group
8. Ferrite buttons circuit
9. Ferrite buttons indicating LEDs
10. External sensors output filter
11. External sensors connector
12. Multiplexer ICs
13. Shield to evaluation board pin connectors
14. PMOD connectors
15. Switch slider PMOD voltage selector
16. 3V3 coin battery holder

9.2 Schematic

9.2.1 Main PCB Schematic Components

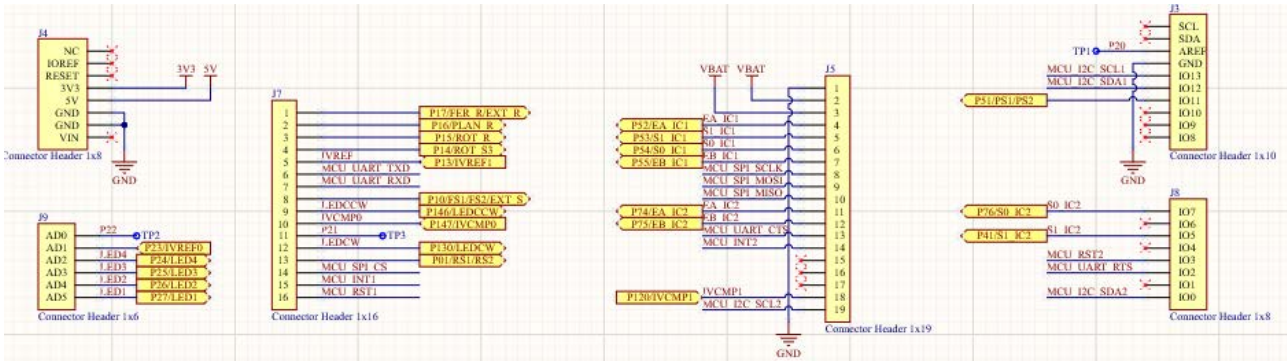

Figure 26. Header & Arduino connectors

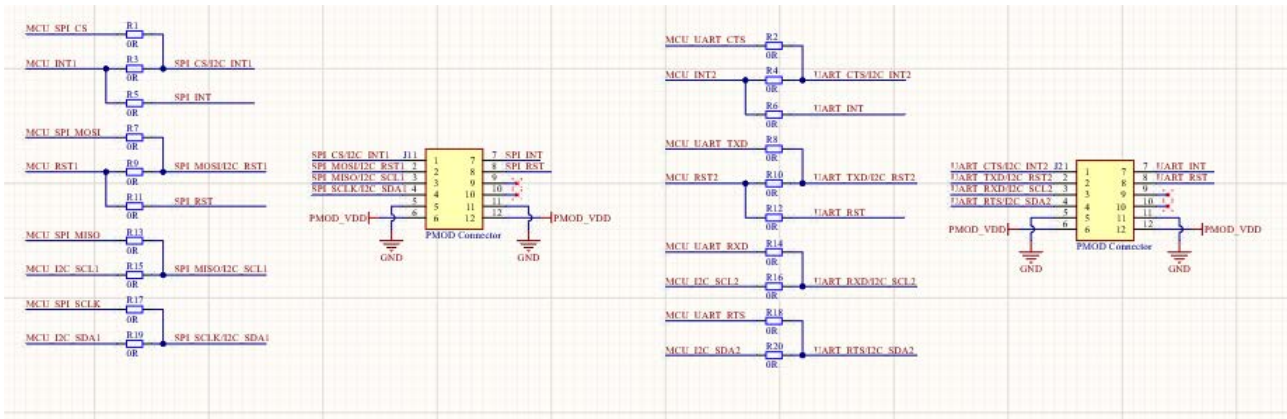

Figure 27. PMOD connectors

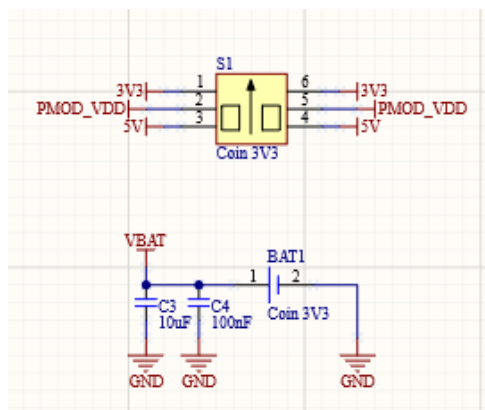

Figure 28. Supply options (+3V3 coin cell & PMOD supply switch)

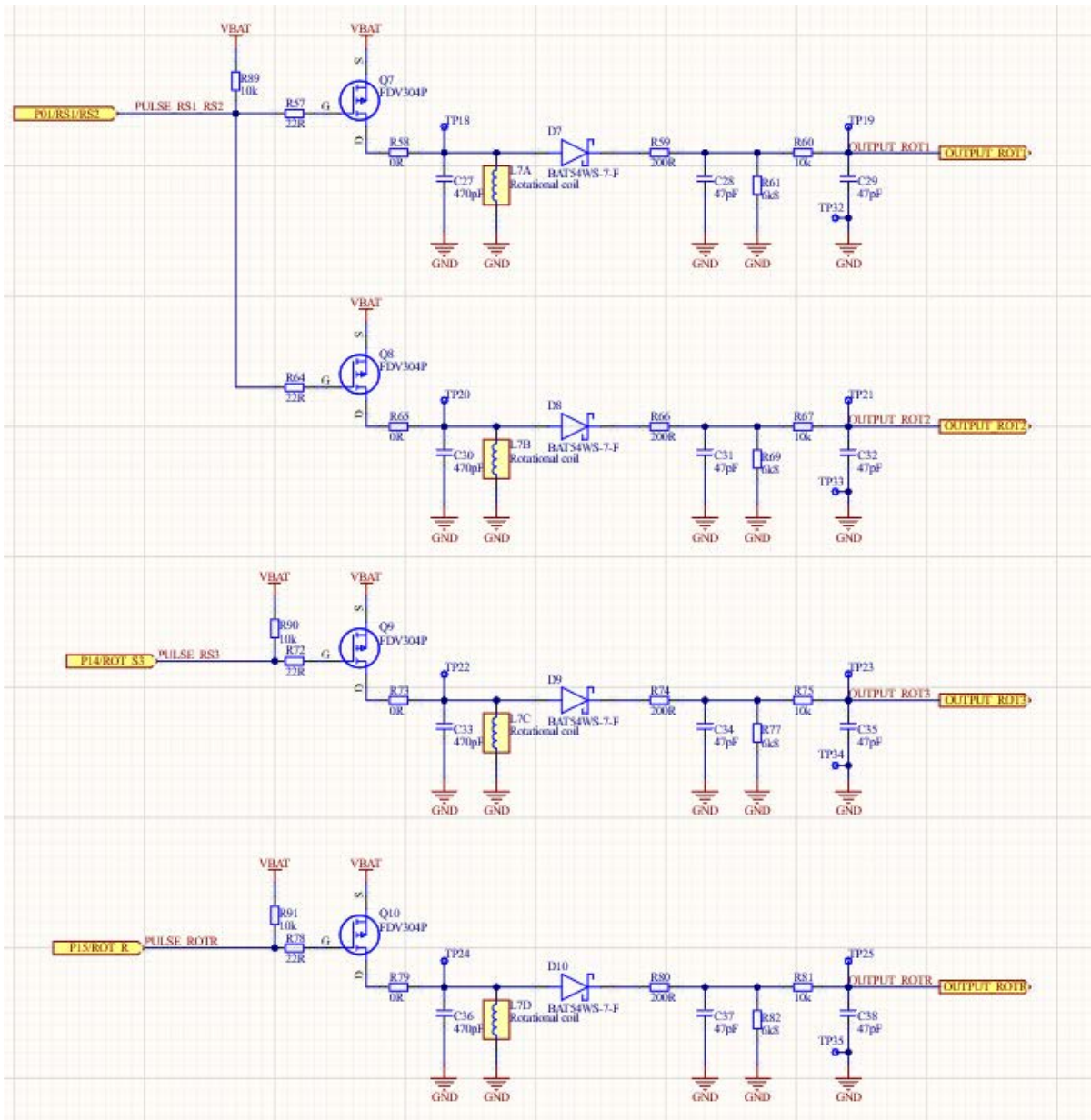

Figure 29. Rotation group (excitation & filters only)

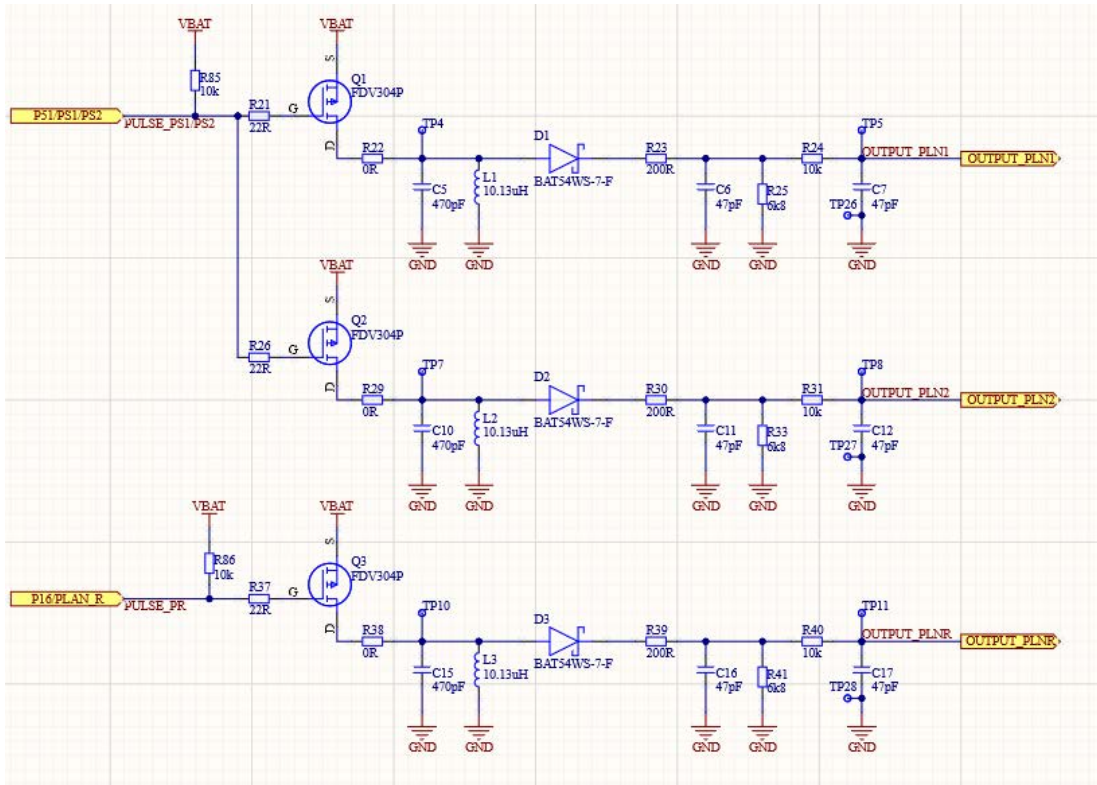

Figure 30. Planar group

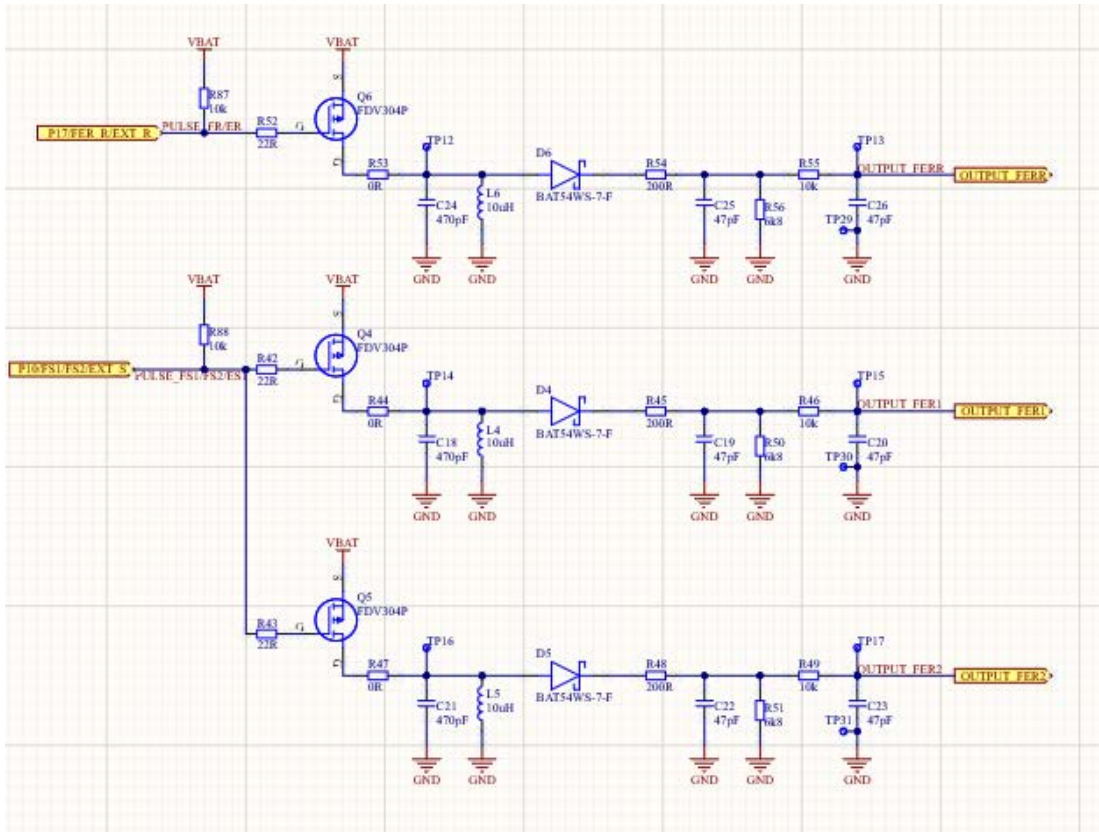

Figure 31. Ferrite group

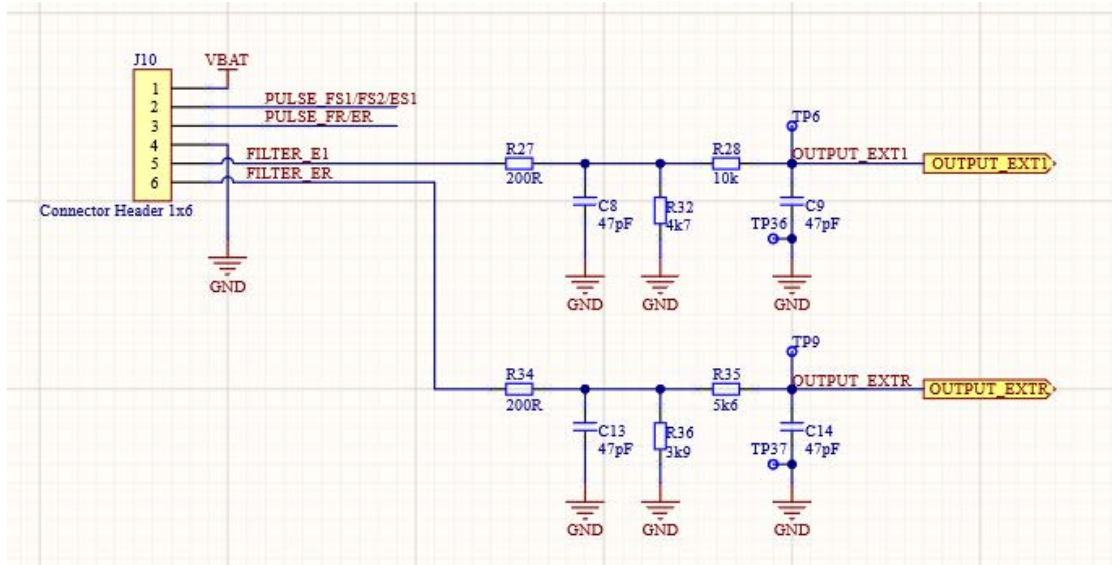

Figure 32. External group (filters only)

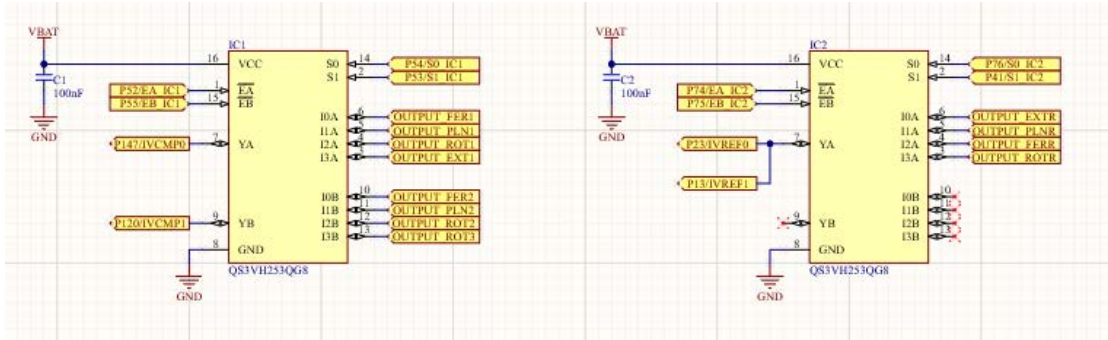

Figure 33. MUX's

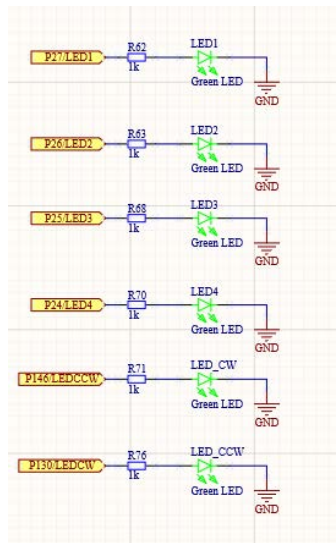

Figure 34. LEDs

9.2.2 Rotation PCB schematic components

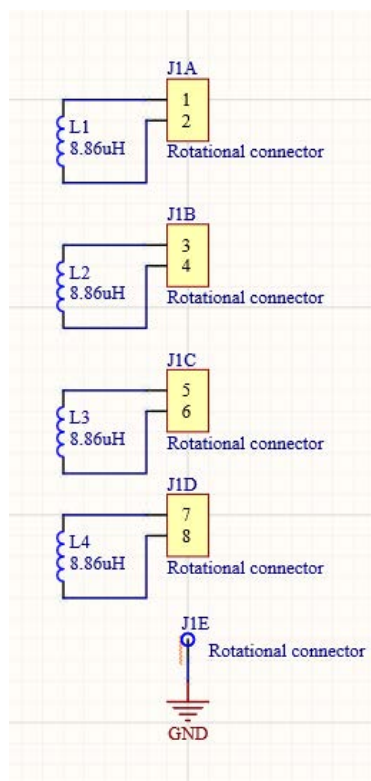

Figure 35. Rotation coils

10. Component interface

The component interfaces section describes the programming interfaces of each of each of the software components that make up the inductive proximity sensing project.

Interface	Description
R_Main_Init()	Starts the initialization of the application layer

Table 5. Start Module Interface

Interface	Description
APP_MuxSelectSensorGroup()	Selects the MUX ICs routing for each coil group
APP_MuxEnableOutput()	Enables MUX ICs channels
APP_MuxDisableOutputs()	Disables MUX ICs channels
APP_DisableLEDs()	Disables all LED in initialization sequence
APP_SetRamDefaultValues()	Call this function if the data flash is empty in initialization sequence or based on diagnosis command if the user wants to restore the default RAM values.

Table 6. Application Module Interface

Interface	Description
DIAG_SendCountInformation()	Sends the current detection counter for each group via UART
DIAG_vResetToDefaultValues()	Diagnosis interface for APP reset data flash
DIAG_vSaveToDataFlash()	Diagnosis interface to save to data flash
DIAG_vReadServiceDispatcher()	Diagnosis interface to check the command ID for write command type
DIAG_vWriteServiceDispatcher()	Diagnosis interface to check the command ID for read command type

Table 7. Diagnostic Module Interface

Interface	Description
ELC_SelectSensorGroup()	ELC toggle based on the 3 x command pins
ELC_InitSensorGroups()	ELC configuration in initialization sequence
ELC_SelectOutputGroup()	ELC internal toggles and disables the unused channels to keep them in HIGH state

Table 8. ELCL Module Interface

Interface	Description
TAU_UpdateTimerValues()	Used to update the correlated values for each sensor group
TAU_u16ConvertUsToCounts()	Converts measurement point period from diagnosis commands to count clock required for timer register.
TAU_u16ConvertMasterNsToCounts()	Converts excitation delay period from diagnosis commands to count clock required for timer register.
TAU_u16ConvertSlaveNsToCounts()	Converts excitation pulse width period from diagnosis commands to count clock required for timer register.
TAU_u16ConvertItMsToCounts()	Converts measurement rate period from diagnosis commands to count clock required for timer register.

Table 9. TAU Module Interface

11. Website and Support

Visit the following URLs to learn about the kit and the RL78 family of microcontrollers, download tools and documentation, and get support.

RL78/G23 64p FPB Resources	RL78/G23-64p Fast Prototyping Board Renesas
RL78 Product Information	RL78 Low Power 8 & 16-bit MCUs Renesas
RL78 Product Support Forum	RenesasRuiz
RL78 Videos	RL78 Family Software & Tool Course Renesas
Renesas Support	renesas.com/support
Inductive Proximity sensor QSG	R12QS0054EG0100
Renesas Inductive Proximity Sensor	www.renesas.com/rl78g23-sensor-shield

Revision History

Rev.	Date	Description	
		Page	Summary
1.00	Jun.6.2022	—	Initial release

Inductive Proximity Sensor Shield – User’s Manual

Publication Date: Jun.6.2022

Published by: Renesas Electronics Corporation

Inductive Proximity Sensor Shield - User's Manual



Renesas Electronics Corporation

R12UZ0106EG0100