

# User Manual

## DA728x Generating LRA Configuration Script

UM-HA-002

### Abstract

*This document describes the procedure for generating an LRA configuration script for an optimal performance of Dialog's DA728x motherboard (359-05-X) and DA7280 daughterboard (359-06).*

---

---

## Contents

<b>Abstract</b> .....	<b>1</b>
<b>1 Terms and Definitions</b> .....	<b>4</b>
<b>2 References</b> .....	<b>4</b>
<b>3 Introduction</b> .....	<b>5</b>
<b>4 Attaching LRA</b> .....	<b>5</b>
<b>5 Setup Procedure</b> .....	<b>6</b>
5.1 Tuning Flow Diagram .....	7
5.2 Examine the LRA's Electrical Characteristics .....	8
5.3 Measure the Impedance and Inductance of the LRA .....	8
5.4 ABS_MAX and NOM_MAX Setup .....	8
5.5 VDD Input Level and Device Output Level .....	8
5.6 Calculate I <sub>MAX</sub> .....	9
5.7 Updating Settings in the GUI .....	9
5.8 Using DA7280 to Measure Resonant Frequency and Impedance .....	10
5.9 K <sub>p</sub> and K <sub>i</sub> Tuning .....	11
5.9.1 LRA Tuning Tool Overview .....	12
5.9.2 Run Default K <sub>p</sub> and K <sub>i</sub> settings .....	13
5.9.3 Example of Stable K <sub>p</sub> and K <sub>i</sub> Response .....	14
5.9.4 Interpreting Results of Repeated Sweeps of the Same K <sub>p</sub> /K <sub>i</sub> Settings .....	14
5.9.5 Example of Unstable K <sub>p</sub> and K <sub>i</sub> Response .....	15
5.9.6 Procedure for Tuning K <sub>p</sub> and K <sub>i</sub> for an LRA .....	16
5.10 Connect Oscilloscope for Debug .....	16
5.11 When to Use Active Acceleration and Rapid Stop .....	17
5.12 Checking Active Acceleration Performance .....	17
5.13 Check Stopping Performance with Rapid Stop Disabled .....	20
5.14 Tuning Rapid Stop Performance .....	22
5.15 Save All Registers .....	24
<b>Appendix A Searching for Registers in the SmartCanvas DA728x GUI</b> .....	<b>26</b>
<b>Appendix B Notes on Using the Acceleration Feature</b> .....	<b>26</b>
<b>Appendix C Overdriving the LRA</b> .....	<b>27</b>
C.1 Acceleration Enabled .....	27
C.2 Acceleration Disabled .....	27
C.3 Rapid Stop OFF .....	27
C.4 Compensating for the BEMF .....	27
<b>Appendix D VDD Margin</b> .....	<b>28</b>
<b>Appendix E Calculating Resonant Frequency</b> .....	<b>28</b>
<b>Appendix F Notes for Driving with PWM</b> .....	<b>29</b>
<b>Appendix G Specific Register Details</b> .....	<b>29</b>
G.1 Tuned Registers Applicable for Every LRA .....	29
G.2 Mode and Configuration Registers that can Be Changed Dynamically .....	30
G.3 Diff'ing Files .....	31

Revision History .....	32
------------------------	----

## Figures

Figure 1: DA728x Motherboard with DA7280 Daughterboard and Default LRA.....	5
Figure 2: LRA Mounted in Mobile Phone .....	6
Figure 3: Ideal Placement of DA728x Motherboard for LRA Testing .....	7
Figure 4: Tuning Flow Diagram .....	7
Figure 5: LRA's Electrical Characteristics .....	8
Figure 6: Entering DC Parameters of the LRA to SmartCanvas DA728x GUI.....	10
Figure 7: Resonant Frequency and Impedance of the LRA Measured by DA7280 .....	11
Figure 8: FRQ_PID_Kp/Ki Registers in the SmartCanvas DA728x GUI.....	11
Figure 9: Launching the LRA Tuning Tool.....	12
Figure 10: LRA Tuning Tool .....	12
Figure 11: Running the Default Kp and Ki Sweep.....	13
Figure 12: Good Frequency Tracking Settling Behavior; Good Loop Stability.....	14
Figure 13: Re-running the Same Sweep .....	15
Figure 14: Poor Frequency Tracking Settling Behavior; Poor Loop Stability .....	15
Figure 15: Connecting Oscilloscope to DA728x Motherboard .....	17
Figure 16: GUI Settings for Checking Active Acceleration Feature .....	18
Figure 17: Startup Output Acceleration with Acceleration Off.....	18
Figure 18: Startup Output Acceleration with Acceleration On.....	19
Figure 19: Example of Acceleration ON Shortens Start-up Time in an LRA.....	20
Figure 20: Setting up the DA728x Motherboard in DRO Mode.....	21
Figure 21: Driving the LRA in DRO Mode .....	21
Figure 22: No Rapid Stop Performance .....	22
Figure 23: Enabling Rapid Stop in SmartCanvas DA728x GUI .....	22
Figure 24: TOP_INT_CFG8.....	23
Figure 25:TST_AMP_RAPID_STOP_LIM Set to 3 - oscillations after stopping .....	24
Figure 26:TST_AMP_RAPID_STOP_LIM = 4 - fast settling time .....	24
Figure 27: Save All Registers .....	25
Figure 28: Search Widget in SmartCanvas DA728x GUI.....	26
Figure 29: Setting V2I_FACTOR_OFFSET_EN in SmartCanvas DA728x GUI .....	26
Figure 30: MEM_DATA_SIGNED Bit .....	27
Figure 31: Scaling Back Drive for Nominal 2 V Output .....	28

## Tables

No table of figures entries found.

## 1 Terms and Definitions

NOTE: "X" can denote different version of boards such as A and B variants

359-05-X	DA728x Motherboard PCB
359-06-X	DA7280 Daughterboard containing DUT
359-07-X	DA7281 Daughterboard containing DUT
359-08-X	DA7282 Daughterboard containing DUT
359-09-X	DA7283 Daughterboard containing DUT
BEMF	Back Electro-Motive Force,
LOOP_CAP	LOOP_FILT_CAP_TRIM Register
LOOP_RES	LOOP_FILT_RES_TRIM Register
LRA	Linear Resonant Actuator
ERM	Eccentric Rotating Mass
DRO	Direct Register Override
FET	Field Effect Transistor
DUT	Device under Test
Override value	The value used to set the output drive level in DRO mode
POR	Power on Reset
PWM	Pulse Width Modulation
Kp	Proportional Coefficient
Ki	Integral Coefficient

## 2 References

- [1] DA7280, Datasheet, Dialog Semiconductor.
- [2] UM-HA-001, DA728x Motherboard User Manual, User Manual, Dialog Semiconductor.

### 3 Introduction

This document describes the procedure to create the configuration script for the **Jahwa 1040 LRA (product number JHV-10L5-L000SB)** which is the default LRA supplied with the DA728x motherboard 359-05-X from Dialog Semiconductor and this procedure can be used to create configuration scripts for other LRAs as well. The hardware setup also uses a Dialog's DA7280 daughterboard 359-06-X which is inserted into the motherboard. **Figure 1** shows the whole hardware setup.

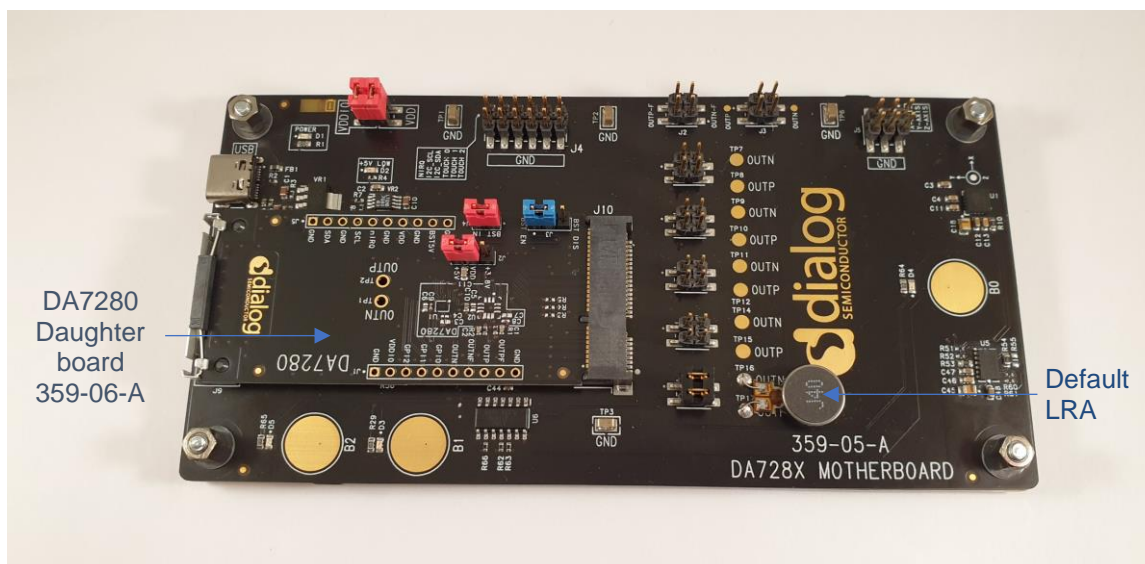

**Figure 1: DA728x Motherboard with DA7280 Daughterboard and Default LRA**

Readers can use the configuration script created in this user manual to customize their own final products.

Further tuning should be carried out in actual products with the LRA properly attached to its final housing, because differences in mechanical coupling and the mass of the final product require changes to the settings.

### 4 Attaching LRA

If the LRA is not mounted on the DA728x motherboard or within a customer product properly, it dramatically affects the LRA performances.. Ideally there should be minimal movement of the LRA body when the LRA vibrates to maximize the momentum transfer to mass.

The LRA supplied with the DA728x motherboard is secured using double sided sticky pads with high adhesion strength. It works adequately but does not represent the optimal way to hold the LRA in a final product. The LRA can also be glued in place for a better mechanical contact but it makes removing and changing the LRA without damaging both the LRA and the motherboard difficult. Please ensure that no glue enters the relief hole on the underside of the LRA when it is glued in place, because glue in the relief hole impedes the LRA performance.

#### NOTE

LRAs that are poorly attached, free floating, or attached to a small mass result in system IRQs.

As the DA728x family of haptics drivers can track frequencies within  $\pm 25\%$  of the resonant frequency specified in the datasheet, it results in system IRQs if an LRA is attached to a mass lower than what it is tuned for, because it vibrates at a higher frequency when there is less mass to be moved. Therefore, it is recommended to further tune the LRA configuration script in final products to compensate real-life mechanical variations.

When designing products for haptic feedback, please consult a mechanical engineer to achieve the best mechanical coupling between the chosen LRA and the product. Ideally for users to feel the vibration in a product, the LRA should move a floating mass in the area where the vibration needs to be felt. A small LRA with low G output has difficulties in vibrating a touch screen panel which is mounted in a product with a large mass. Please refer to the datasheet of a chosen LRA for advice on its mechanical placement and fixation method. For example, a custom housing gripping the LRA on all sides is usually the preferred method in mobile phones (Figure 2).



Figure 2: LRA Mounted in Mobile Phone

## 5 Setup Procedure

The DA7280 daughterboard (359-06-X) is referenced as the device under test (DUT) in this document but the DA728x motherboard also supports the DA7281 (359-07-X), DA7282 (359-08-X), and DA7283 (359-09-X) daughterboards.

It is important to follow this setup procedure sequentially. At the end of this process, a configuration script will be saved that should be downloaded to DA7280 after power on reset (POR).

Ensure that the DA7280 daughterboard is securely attached to the DA728x motherboard (359-05-X).

Connect the DA728x motherboard to a computer and run the SmartCanvas DA728x GUI.

As shown in Figure 3, the DA728x motherboard should be placed on a foam or sponge to remove any damping effect caused by a firm surface.



Figure 3: Ideal Placement of DA728x Motherboard for LRA Testing

### 5.1 Tuning Flow Diagram

Each step shown in Figure 4 is detailed in the following subsections.

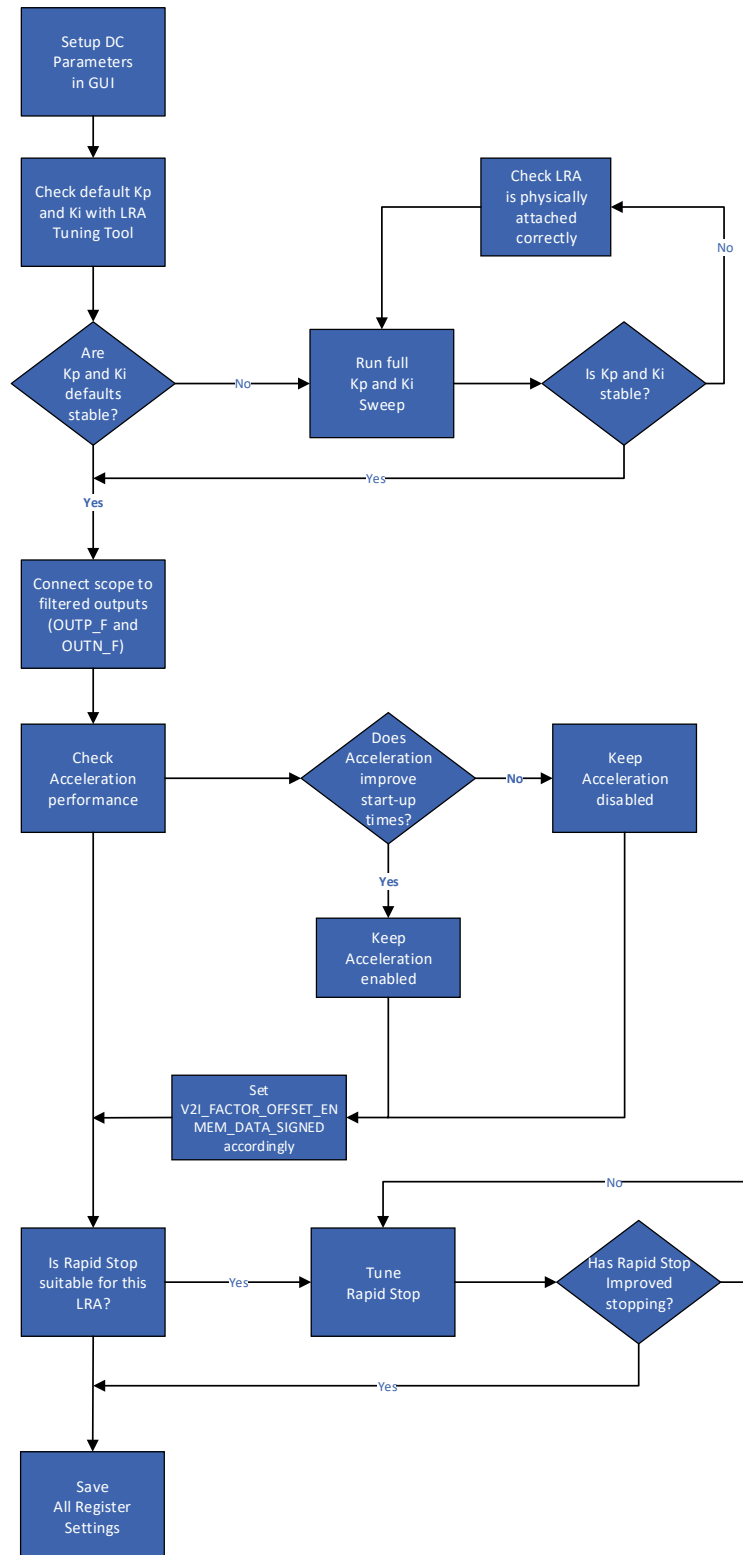

Figure 4: Tuning Flow Diagram



## 5.2 Examine the LRA's Electrical Characteristics

Use the LRA's electrical characteristics listed in its datasheet as the basis for driving the LRA correctly. See [Figure 5](#) for the electrical characteristics of Jahwa 1040.

Item	Condition	Specification
Rated voltage		2.5V <sub>rms</sub> ( Sinewave )
Resonant frequency		170 Hz ± 5
Rated current	2.5V <sub>rms</sub>	Max. 170 mA
Terminal resistance	Between terminals	12±2Ω
Noise	2.5V <sub>rms</sub>	Touch : Max. 35dB Band : Max. 35dB THD : Max. 25%

**Figure 5: LRA's Electrical Characteristics**

## 5.3 Measure the Impedance and Inductance of the LRA

Before connecting the LRA to the DA728x motherboard, use an LCR meter to measure the actual impedance and inductance between the two terminals of the motor, this is especially important with the inductance as this parameter is often not mentioned in LRA datasheets. The results of the measurement are shown below for the supplied LRA:

- Measured impedance = 13.1 Ω
- Measured inductance = 354 μH

Please refer to the LCR user manual when carrying out this measurement, because depending on the LCR test frequency the measurement results may vary.

## 5.4 ABS\_MAX and NOM\_MAX Setup

Set ABS\_MAX and NOM\_MAX to be of the same value as indicated in the LRA datasheet. For the default Jahwa 1040 LRA the value is 2.5 V. See [section 5.7](#).

- NOM\_MAX is the nominal maximum RMS voltage
- ABS\_MAX is the absolute maximum RMS voltage
- If ACCELERATION = Disabled, unsigned full scale is set by ABS\_MAX, NOM\_MAX is ignored
- If ACCELERATION = Enabled, unsigned full scale is set by NOM\_MAX, and ABS\_MAX is the level reached when the LRA is overdriven by the automatic algorithm in DA7280

It is recommended to set ABS\_MAX above NOM\_MAX when the Acceleration feature is enabled to allow the DA7280 to overdrive the LRA for short periods.

## 5.5 VDD Input Level and Device Output Level

Please note that the VDD level of the DA7280 device can be set to either 3.8 V - (supplied from the DA728x motherboard) or 5V (default) - (supplied by an on-board boost circuit which is on the 359-06-X daughterboard). This can be selected by using the J2 jumper on the DA7280 daughterboard.

The other daughterboards (DA7281, DA7282, and DA7283) are hardwired to only be supplied by the motherboard VDD at a default level of 3.8 V but can be supplied at other levels as explained in the UM-HA-001 - DA728X motherboard manual.



When the DA7280 daughterboard is operated at VDD = 3.8 V, its output is limited by this VDD input voltage level and the full voltage range of ABS\_MAX and NOM\_MAX is not used (the maximum output is around 2.8 V). This level of 2.8 V is adequate for most LRAs, but a higher VDD level may be needed to overdrive the LRA for short periods.

To use the full output voltage range, the VDD of the DA7280 daughterboard needs to be set to 5 V or be supplied externally (MAX VDD=5.5V). Please refer to the DA728x motherboard user manual [2] for more details.

## 5.6 Calculate I<sub>MAX</sub>

Always allow for 10% extra I<sub>MAX</sub> current specified by the LRA manufacturer to compensate for the BEMF. If no I<sub>MAX</sub> is specified in the datasheet, please use the value of the ABS\_MAX voltage divided by the measured impedance. The I<sub>MAX</sub> value for the default Jahwa 1040 LRA is 170 mA × 1.1 = 187 mA.

## 5.7 Updating Settings in the GUI

Manually enter the following values (or as close as possible) into the SmartCanvas DA728x GUI using the sliders and numerical entry boxes (see Figure 6). Always ensure that **ENTER** is pressed after each entry is made in the GUI.

- Set **Abs Max** = 2.5 using the slider.
- Set **Nom Max** = 2.5 using the slider.
- Set **I Max** = 0.187 using the slider.
- Set **Override Value** = 0.6 using the sliders. The value is the scaled output level of the device (0.6 = 60% output) and is used when the DA728x motherboard is operated in DRO mode and when K<sub>p</sub>/K<sub>i</sub> is being tuned (see section 5.9).
- Type 170 into the **Resonant Frequency** field then hit **Enter**.
- Type 13.1 into the **Impedance** field then hit **Enter**.
  - The GUI automatically calculates the V2I settings and writes these to the CALIB\_V2I\_H and CALIB\_V2I\_L registers.
- Type 354 into the **Inductance** field then hit **Enter**.
  - The GUI automatically sets the LOOP\_CAP and LOOP\_RES trim values in the registers, these correspond to impedance and inductance values which are used in a lookup table to determine the values (see DA7280 datasheet for more information).

The screenshot displays the SmartCanvas DA728x GUI configuration interface. It is divided into two main sections: 'Settings' and 'Actuator / Supply Information'.

**Settings Panel:**

- Drive Type:** Radio buttons for ERM and LRA (selected), with a 'Coin' button.
- Operation Mode:** A dropdown menu currently set to 'Inactive mode'.
- Settings:**
  - Frequency Tracking: On (green button)
  - Acceleration: Off (grey button)
  - Rapid Stop: Off (grey button)
  - Abs Max (V): Slider and input field showing 2.5038
  - Nom Max (V): Slider and input field showing 2.5038
  - I Max (A): Slider and input field showing 0.187
  - Override Value: Slider and input field showing 0.6004

**Actuator / Supply Information Panel:**

- ADC VDD:** Input field showing 4.962891
- Impedance / Resonant Frequency Initial Settings:** (Highlighted with a red box)
  - Resonant Frequency (Hz): 170.11
  - Impedance ( $\Omega$ ): 13.1
  - Inductance ( $\mu\text{H}$ ): 354
- Impedance / Resonant Frequency Status:**
  - Resonant Frequency (Hz): 169.07
  - Impedance ( $\Omega$ ): 13.25

Figure 6: Entering DC Parameters of the LRA to SmartCanvas DA728x GUI

## 5.8 Using DA7280 to Measure Resonant Frequency and Impedance

To use the DA7280 daughterboard to accurately measure the resonant frequency and impedance of the LRA, set the operation mode in the SmartCanvas DA728x GUI to **'Direct register override'** to drive the LRA. You should now feel the LRA buzzing.

The GUI will report the actual LRA resonant frequency and impedance values while the LRA is being driven (Figure 7) and these values are used to update the DA7280 settings automatically, so that the next time a haptic effect is driven, DA7280 will use the newer and more accurate values as a starting point. This can be very useful to tune an attached LRA.

The resonant frequency and impedance of the LRA should also be re-measured and checked when the final configuration scripts for products in final plastics are being tuned. This is done to be sure the final configuration scripts cover the LRA being test with a  $\pm 25\%$  variation in resonant frequency, impedance, BEMF settings and also for the final true weight of the product.

When tuning, If a particular LRA being used to create to create the initial configuration script is on the extreme edge of manufacturing tolerances, consider testing with more median LRA samples and the possible variants according to the datasheet of the selected LRA. This should be done to ensure the script works will all tolerances of actuators.

After the resonant frequency and impedance of the LRA are measured, switch the operation mode back to INACTIVE to stop driving the LRA.

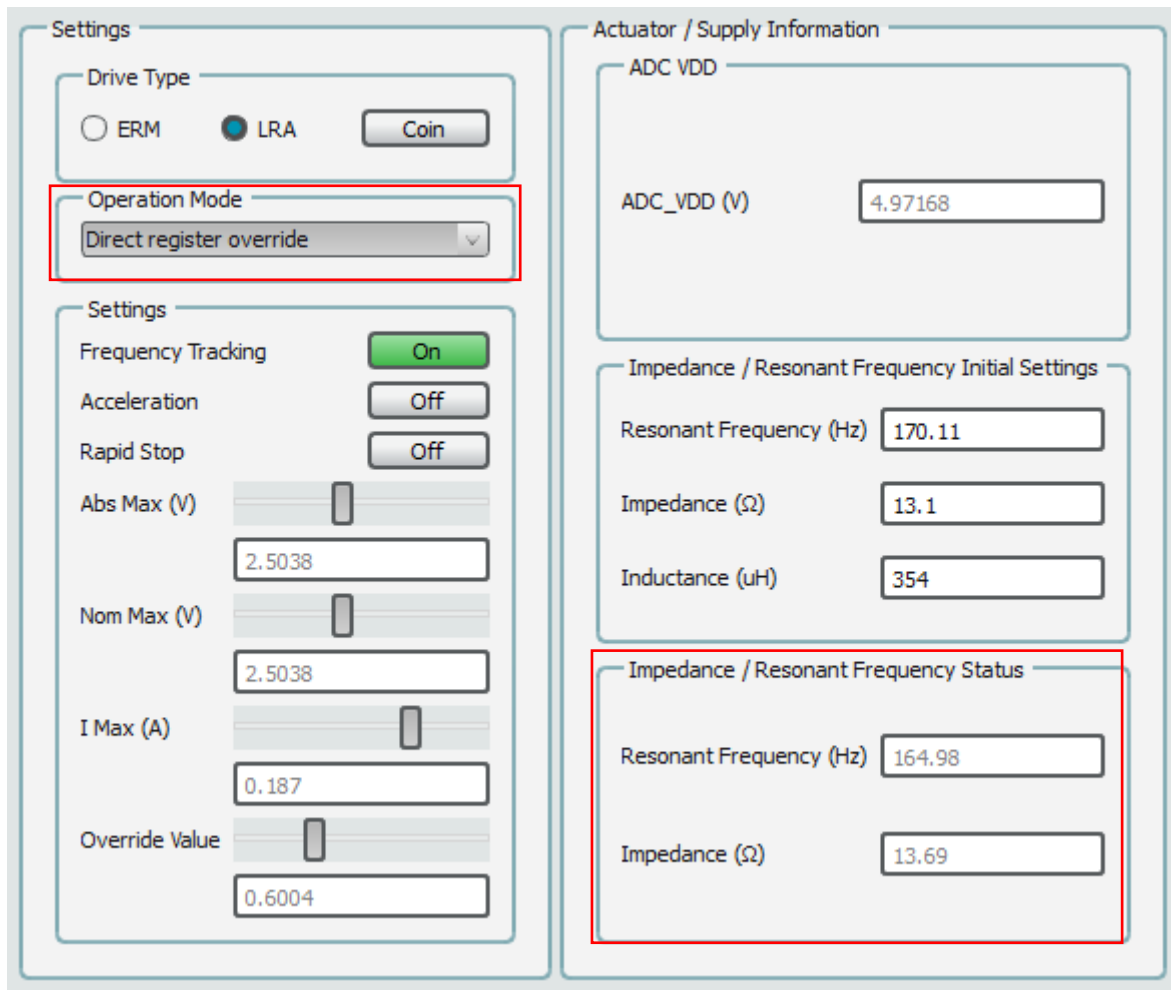

Figure 7: Resonant Frequency and Impedance of the LRA Measured by DA7280

### 5.9 Kp and Ki Tuning

The closed-loop frequency tracking by DA7280 is implemented via a proportional-integral (PI) controller. A good closed-loop frequency tracking ensures the features of resonant frequency tracking and Rapid Stop work as optimally as possible.

The proportional coefficient (Kp) is stored in the registers FRQ\_PID\_Kp\_H/L and the integral coefficient (Ki) is stored in the registers FRQ\_PID\_Ki\_H/L. The default values of the coefficients are optimized to cover a wide range of LRA actuators with a typical settling time of approximately 40 ms from a 20% frequency offset.

The Kp and Ki registers can be found in the **SYSTEM** tab in the SmartCanvas DA728x GUI (Figure 8).

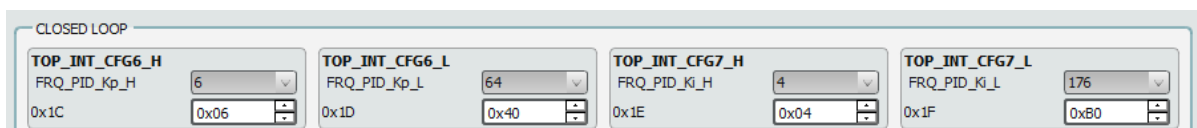

Figure 8: FRQ\_PID\_Kp/Ki Registers in the SmartCanvas DA728x GUI

### 5.9.1 LRA Tuning Tool Overview

The SmartCanvas DA728x GUI has an LRA Tuning Tool plugin to automatically calculate the best Kp and Ki values for a given LRA. In **Tools** select **LRA Tuning Tool** (Figure 9).

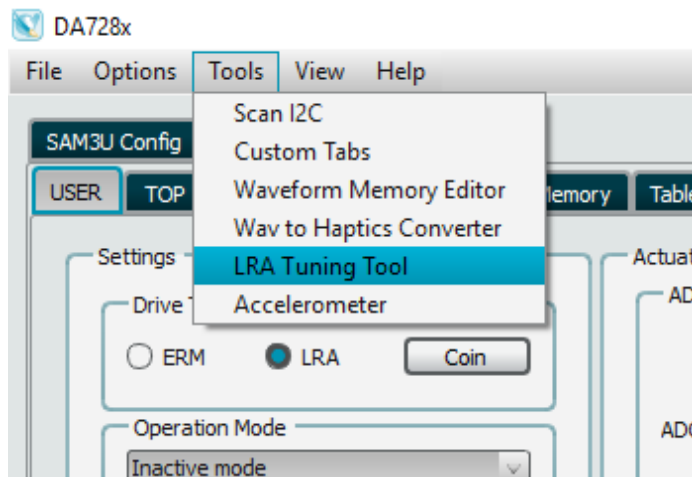

Figure 9: Launching the LRA Tuning Tool

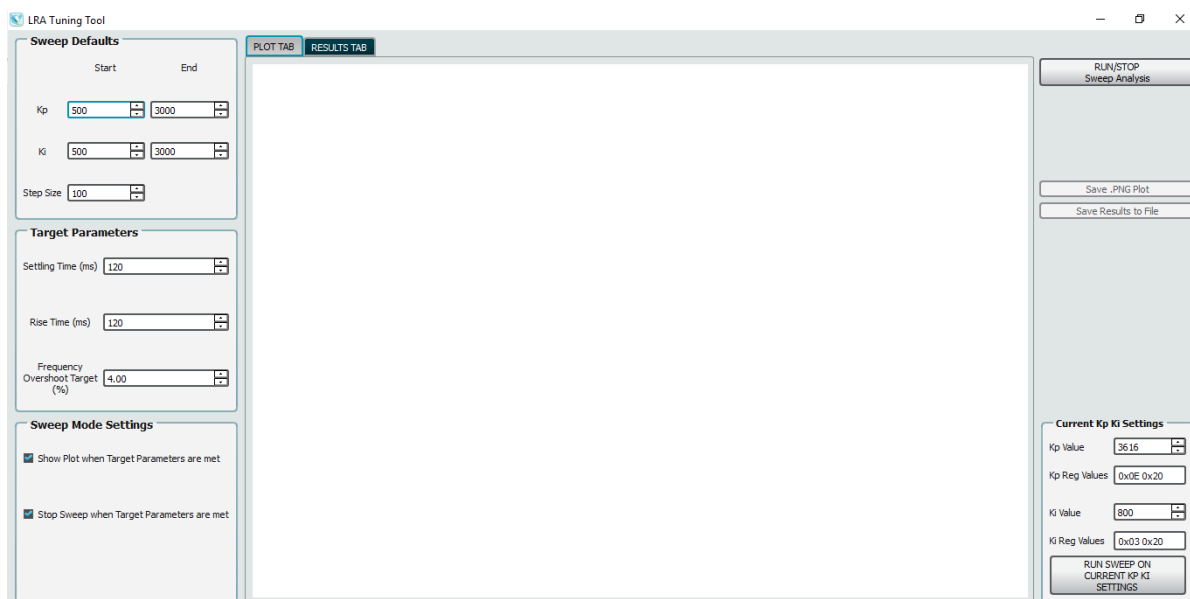

Figure 10: LRA Tuning Tool

- **Sweep Defaults:** these are the start and stop limits for the Kp and Ki coefficients.
- **Target Parameters:**
  - **Settling Time:** this is the time for the resonant frequency to settle to within 0.5 Hz of the initial resonant frequency level.
  - **Rise Time:** this is the time for the resonant frequency tracking to cross the initial resonant frequency level.
  - **Frequency Overshoot Target:** this is the percentage overshoot of the initial resonant frequency target.
- **Sweep Mode Settings:**
  - **Show Plot when Target Parameters are met:** when this choice is selected, the plot will only be shown when the actual settling time, rise time, and frequency overshoot targets are below

the values set in **Target Parameters**. When this choice is not selected, every plot will be shown regardless of Target Parameters.

- **Stop Sweep when Target parameters are met** (set by default): the sweep stops and cannot be continued from the stop point.
- **RUN/STOP Sweep Analysis**: run the entire sweep analysis as defined by the Kp and Ki defaults from the initial settings.
- **Current Kp Ki Settings**: run the sweep analysis as defined by current Kp and Ki settings.

### 5.9.2 Run Default Kp and Ki settings

The Kp/Ki sweep sets the default resonant frequency of the LRA and drives the LRA in DRO mode. At the 1 second mark in [Figure 11](#), the resonant frequency is deliberately shifted by 20% lower and the response of the closed-loop frequency tracking is plotted to see how the system reacts and adjusts to re-track the resonant frequency with the selected Kp/Ki parameters. Users can then select a better settling behavior by changing the Kp/Ki settings with regards to settling time, stability, and overshoot.

In each plot the frequency shift offset is performed several times as shown in the GUIs blue trace which shows the average frequency response plotted using the DA7280 resonant frequency readback registers. Ideally the resonant frequency should re-settle back to the true resonant frequency as quickly as possible. The overshoot should be low and the settling time should be as short as possible. Depending on the LRA being tuned and how fast/slowly it responds, the target parameters may need to be changed and requires some experimentation and is usually a balance between aggressiveness, time and stability.

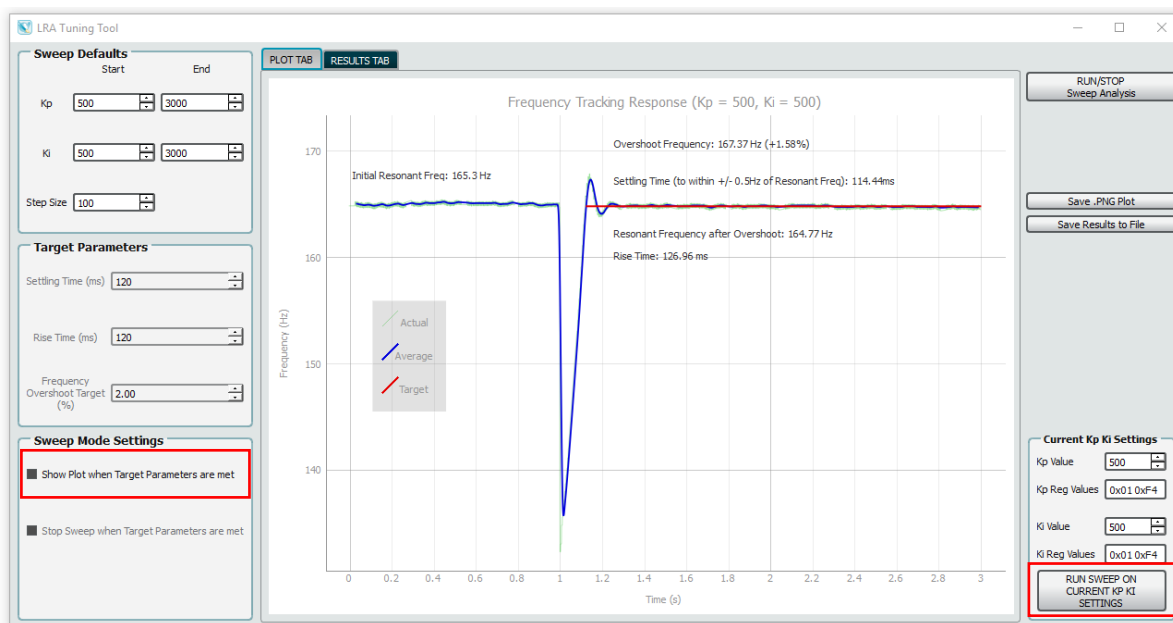

**Figure 11: Running the Default Kp and Ki Sweep**

From the plot in [Figure 11](#) we can read the following information:

- Rise time: 126.96 ms. It should be considered as a slow response and it can be changed with different Kp/Ki settings.
- Overshoot: very low overshoot of 1.58%. Ideally this value should always be <2%.
- Settling time: the settling time is reasonable at 114.44 ms.
- The ringing/oscillation behavior in the settling period as it tries to re-sync to the resonant frequency, suggests the Kp and Ki default settings are stable.

This LRA has a rise time of 10ms and falling time of 50ms from the LRA datasheet parameters, so it reacts very quickly to electrical stimulus. It suggests the rise and settling figures above can be improved with different Kp/Ki settings.

### 5.9.3 Example of Stable Kp and Ki Response

Figure 12 shows a full sweep analysis run with the set **Target Parameters**. The **Frequency Overshoot Target (%)** is set to 2%. The **Show Plot when Target Parameters are met** and **Stop Sweep when Targets Parameters are met** are ON. The plot Figure 12 is shown when the target parameters are met and it shows the fastest way to run the entire sweep analysis.

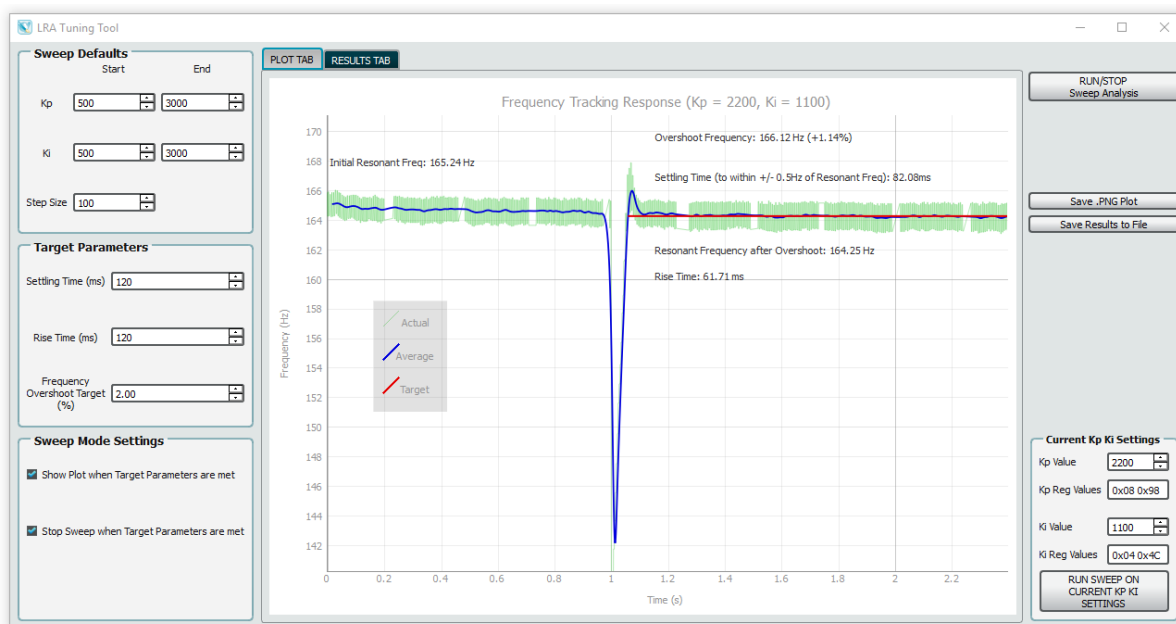

Figure 12: Good Frequency Tracking Settling Behavior; Good Loop Stability

The following observations can be made:

- Rise time: ~62 ms, meaning the LRA rises fast.
- Overshoot: low overshoot of 1.14% and less than Target of 2%.
- Settling time: short settling time at ~82 ms with good damping in the settling period.
- The Kp and Ki values lead to short rise/fall time and stable performance.

### 5.9.4 Interpreting Results of Repeated Sweeps of the Same Kp/Ki Settings

Figure 13 shows the same Kp/Ki settings as the previous sweep. The rise time is roughly the same, but the settling time has increased to 113.92 ms. This can be expected as you are measuring the response of the LRA which is a mechanical system. The stability of the rise time is the most important characteristic that should be repeatable.

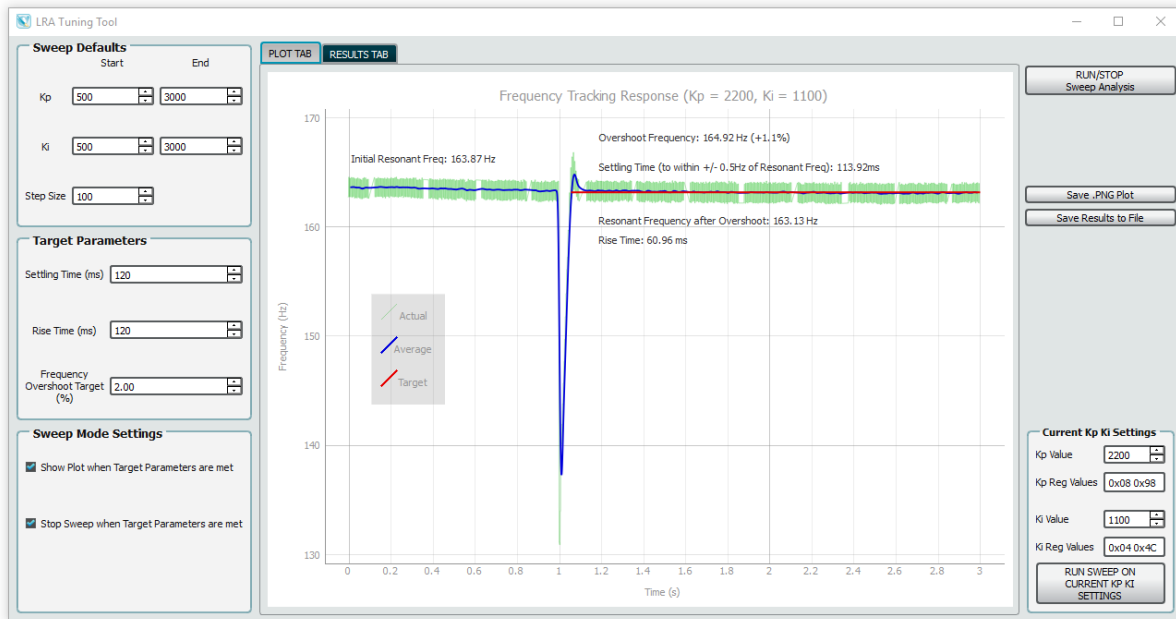

Figure 13: Re-running the Same Sweep

### 5.9.5 Example of Unstable Kp and Ki Response

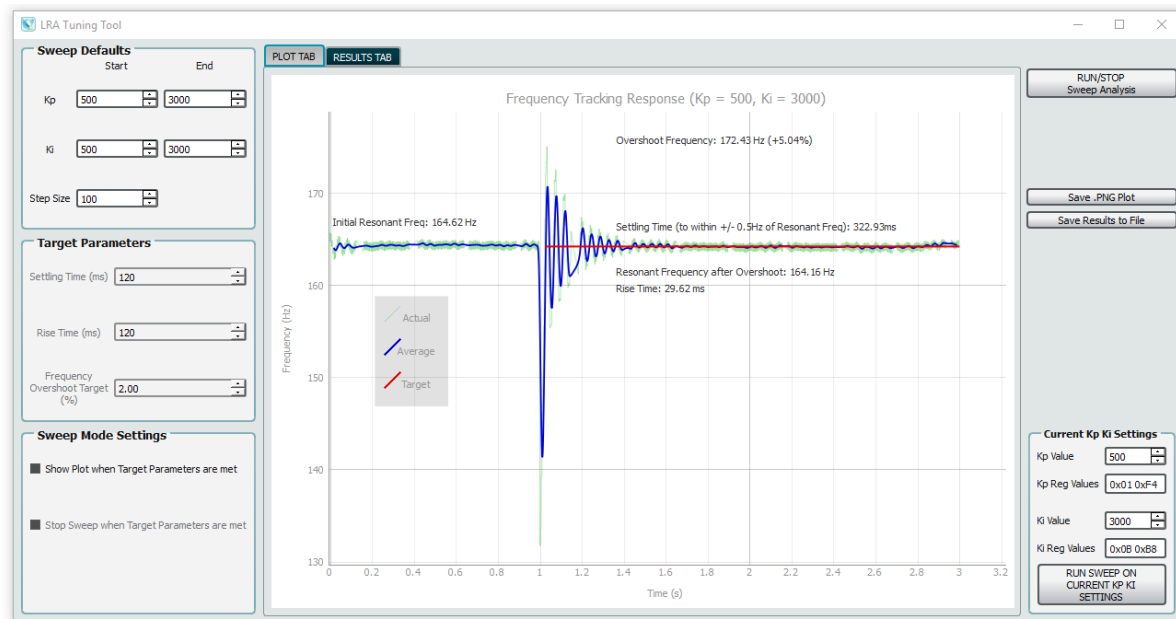

Figure 14: Poor Frequency Tracking Settling Behavior; Poor Loop Stability

From Figure 14 we can read the following information:

- Rise time: 29.62 ms, very fast.
- Overshoot: large overshoots hitting +5.04%, much higher than the target parameter.
- Settling time: the settling time is 322.93 ms with very poor damping and unstable oscillations.

These Kp and Ki settings result in very unstable LRA performances.



### 5.9.6 Procedure for Tuning Kp and Ki for an LRA

1. Ensure **Operation Mode** is set to **Inactive Mode** in the **USER** Tab of the main SmartCanvas DA728x GUI.
2. Ensure the DA728x motherboard is isolated from a hard surface with a foam or sponge and the LRA is mounted correctly.
3. Keep the initial **Sweep Defaults** as indicated in the SmartCanvas DA728x GUI.
4. Change **Target Parameters > Frequency Overshoot Target** to 2%.
5. Keep **Sweep Mode Settings** as indicated in the SmartCanvas DA728x GUI.
6. Press the “**RUN SWEEP ON CURRENT KP AND KI SETTINGS**”
  - a. Determine whether the default settings are stable (see section 5.9.2). If they are not stable, continue with the next step.
7. Press **RUN/STOP Sweep Analysis** button. A full Sweep analysis is run and may take up to 20 minutes.
8. The LRA Tuning Tool now begins to capture the data for the frequency tracking response.
  - a. By deselecting the **Show Plot when Target Parameters are met**, each plot is shown regardless of whether the responses meet the target parameters, therefore the overall run time of the sweep becomes longer.
  - b. With **Stop Sweep when Target parameters are met** box checked, the sweep analysis is stopped when target parameters are reached.
9. When a sweep response meets the target parameters, it can be visually observed that the ringing within the settling period is stable (see section 5.9.3).
10. The TOP\_INT\_CFG6 and TOP\_INT\_CFG7 registers now hold the correct Kp and Ki values for this LRA.

### 5.10 Connect Oscilloscope for Debug

Ensure the DA728x motherboard is not directly in contact with a hard surface. It should be placed on a foam or sponge to prevent damping from the hard surface.

Ensure that the oscilloscope grounds are connected to GND connectors available on the DA728x motherboard (Figure 15).

- Oscilloscope channel 1 to OUTN\_F (Connector J2 pin 2 or 4)
  - This is the filtered OUTN signal from DA7280
- Oscilloscope channel 2 to OUTP\_F (Connector J2 pin 1 or 3)
  - This is the filtered OUTP signal from DA7280
- Oscilloscope channel 3 to Z-AXIS analog accelerometer output (Connector J5 pin 1)
  - Please make sure that the oscilloscope is set to **AC coupling** for this channel.

The default Jahwa 1040 LRA vibrates in the Z-AXIS. Please adjust the connection to X, Y, or Z axis, depending on the LRA being tuned.

When placing an LRA vibrating on the X or Y axis, it is important to mount the LRA in a way that its axis of movement is in line with the DA728x motherboard PCB.. Otherwise, the accelerometer output vibrations will be seen on both X and Y axis.

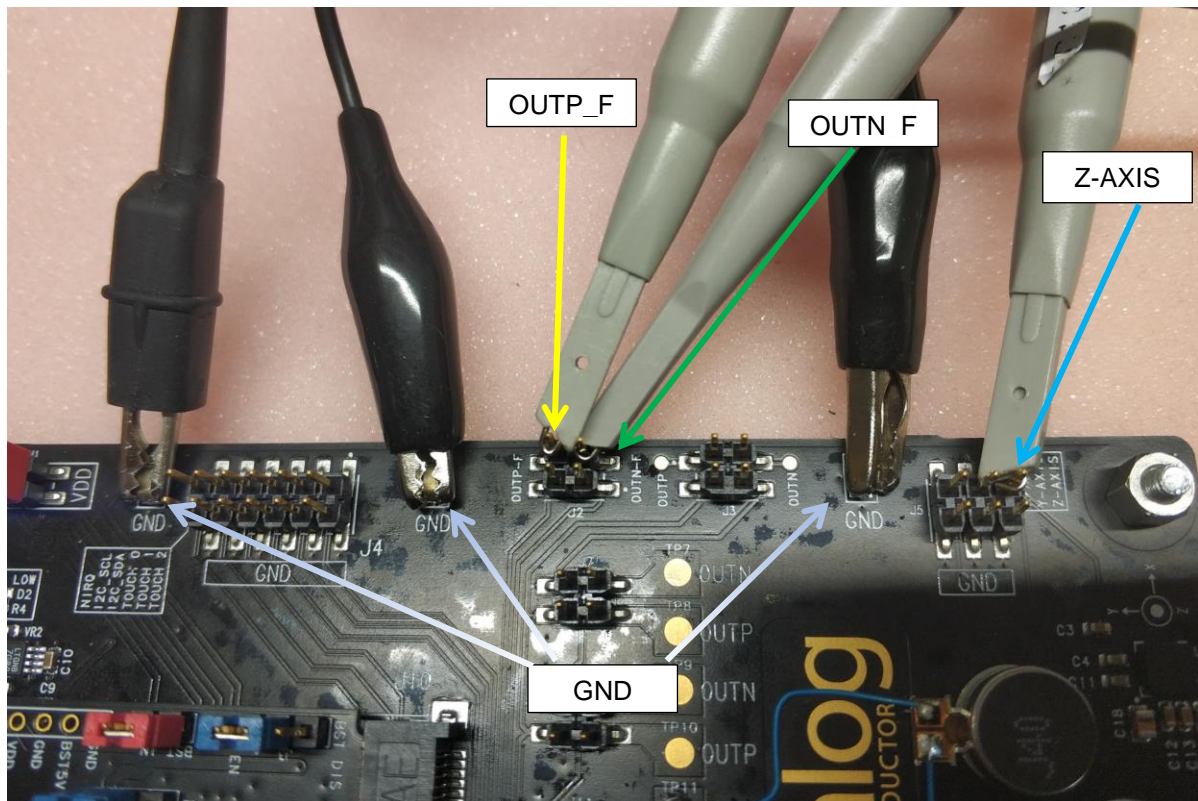

Figure 15: Connecting Oscilloscope to DA728x Motherboard

### 5.11 When to Use Active Acceleration and Rapid Stop

The features of Active Acceleration and Rapid Stop in the DA728X only work when frequency tracking is enabled.

Active Acceleration works the best on actuators with slow start up times (> 40ms) and it does not require any calibration. The overdrive voltage level is set by ABS\_MAX which can be found in the LRA datasheet. But not all LRAs can be overdriven.

Rapid Stop feature only works for sequences longer than 3 half periods and requires calibration (see section 5.14). For very fast actuators (with start times < 40 ms), the Rapid Stop feature may not function optimally and it may require manual operation to stop the LRA (see section "JAHWA\_1040\_FREQ\_TRACK\_ON" and check the waveform in "Sequence 2" in [2]).

When Rapid Stop is OFF, it is recommended that the TST\_AMP\_RAPID\_STOP\_LIM register in TOP\_INT\_CFG8 should be set to 7.

### 5.12 Checking Active Acceleration Performance

To check the active acceleration performance of the LRA, use the GUI settings shown in Figure 16 with **Frequency Tracking** set to On and **Acceleration** set to Off. Note that the values in **Abs MAX** and **Nom MAX** are now different from the previous settings used when first configuring the device.

When active acceleration is turned on, the overdrive voltage is scaled at 1.5 times the nom max voltage setting during this overdrive period. This overdrive voltage can be limited to the value set in abs max but should scale with the IMAX setting and actuator impedance.

It is also possible to increase ABS\_MAX to overdrive the LRA beyond the datasheet specification, however the start-up time does not improve significantly for this LRA.

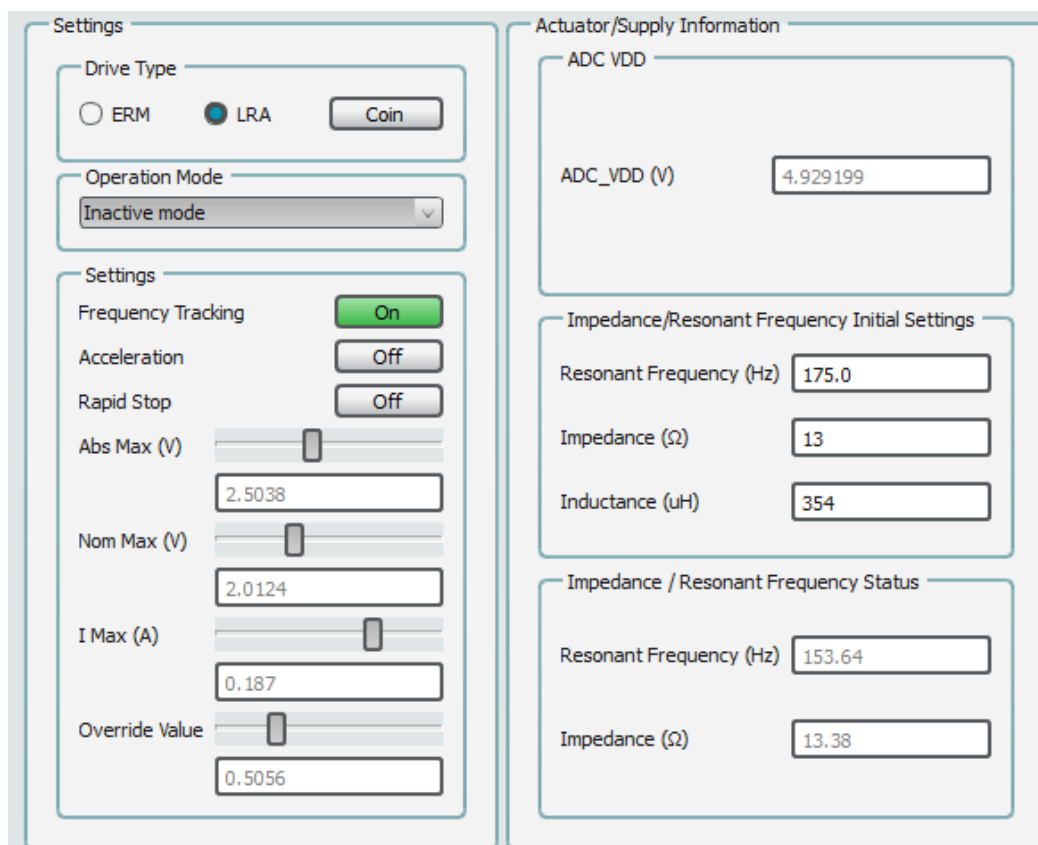

Figure 16: GUI Settings for Checking Active Acceleration Feature

With **Acceleration** set to Off, change the mode in **Operation Mode** to **Direct Register Override** and capture the startup output acceleration (Figure 17).

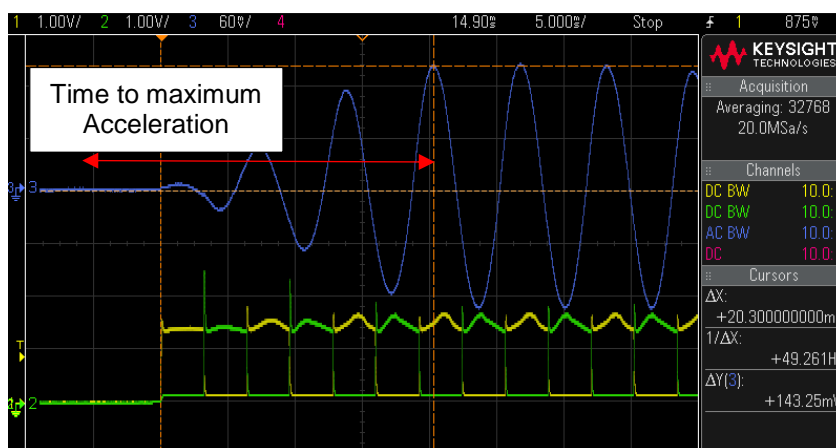
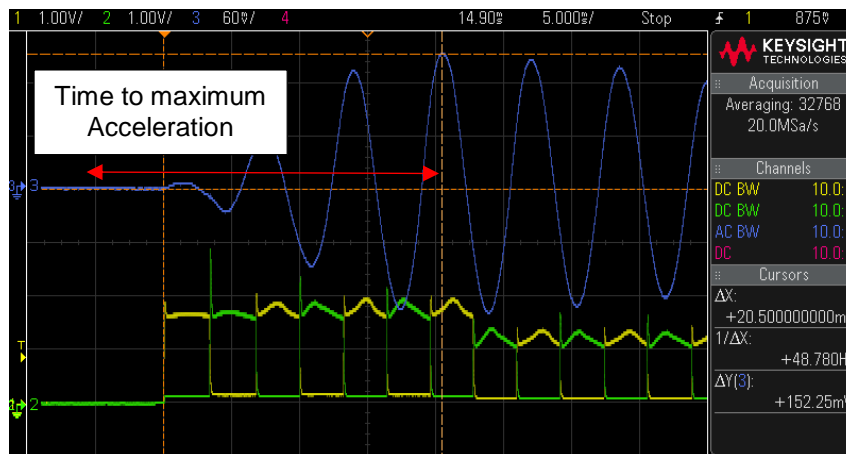

Figure 17: Startup Output Acceleration with Acceleration Off

- Oscilloscope channel 1 (yellow trace) shows OUTN filtered signal.
- Oscilloscope channel 2 (green trace) shows OUTP filtered signal.
- Oscilloscope channel 3 (blue trace) shows the Z-axis acceleration signal from the accelerometer.
- This LRA reaches the maximum output acceleration of 143.25 mV in 20.3 ms with **Acceleration** Off.

Change the **Operation Mode** back to **Inactive**, switch **Acceleration** On, and then change the mode to **Direct Register Override** and capture the startup output acceleration (Figure 18).



**Figure 18: Startup Output Acceleration with Acceleration On**

This LRA reaches the maximum output acceleration of 152.25 mV in 20.5 ms with **Acceleration On**.

Therefore, enabling the Active Acceleration feature has no real impact on the startup time of this LRA, because with or without the Active Acceleration feature it takes around 20 ms to reach the maximum output acceleration or maximum drive signal level. The extra output acceleration of ~6% with **Acceleration On** can be observed to stay at the same nominal level in both cases within two to three full periods. So, the Active Acceleration feature should be switched off for this LRA.

When working with LRAs that have slow start-up times, with **Acceleration On**, the time from startup to reach the maximum output acceleration should be shortened (see [Figure 19](#) for an example).

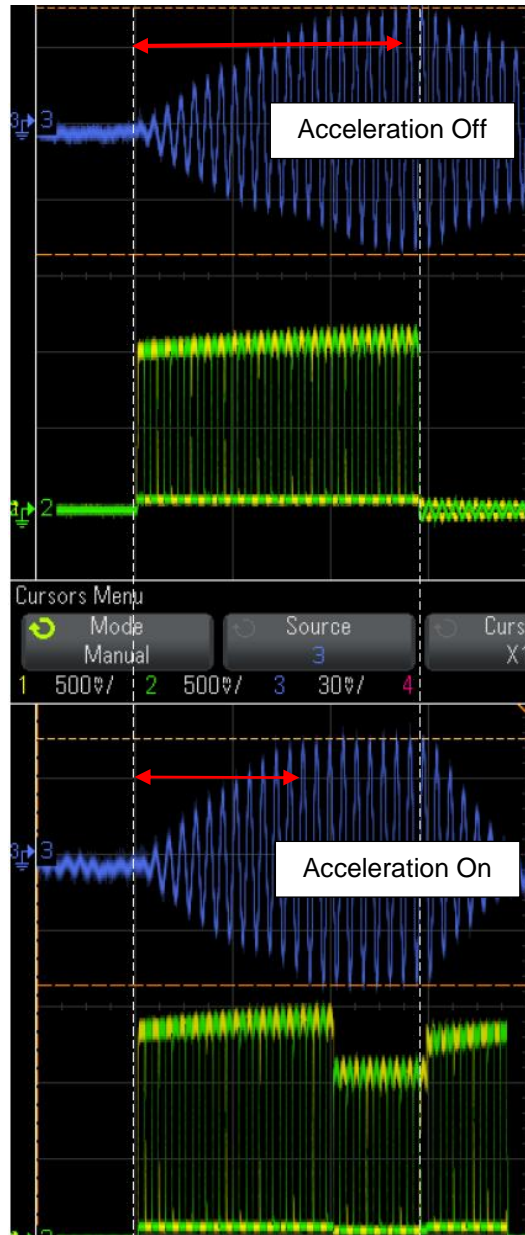

Figure 19: Example of Acceleration ON Shortens Start-up Time in an LRA

### 5.13 Check Stopping Performance with Rapid Stop Disabled

In the SmartCanvas DA728x GUI, set ABS\_MAX and NOM\_MAX as shown in Figure 20, set the **Override Value** close to 0.5, and set the **Operation Mode** to **Direct Register Override (DRO)**.

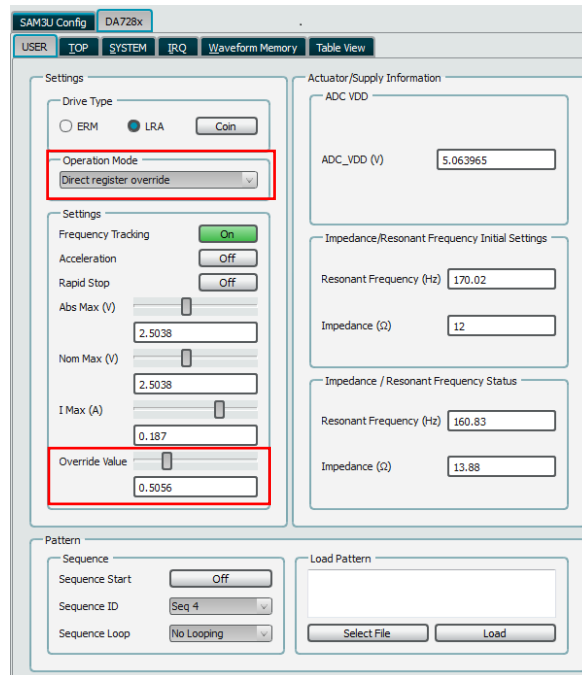

Figure 20: Setting up the DA728x Motherboard in DRO Mode

The signals on the oscilloscope should look like Figure 21: the LRA is oscillating at its resonant frequency of around 161 Hz as can be seen from the GUI resonant frequency readback. This is producing a 157 mV peak-to-peak signal from the accelerometer.

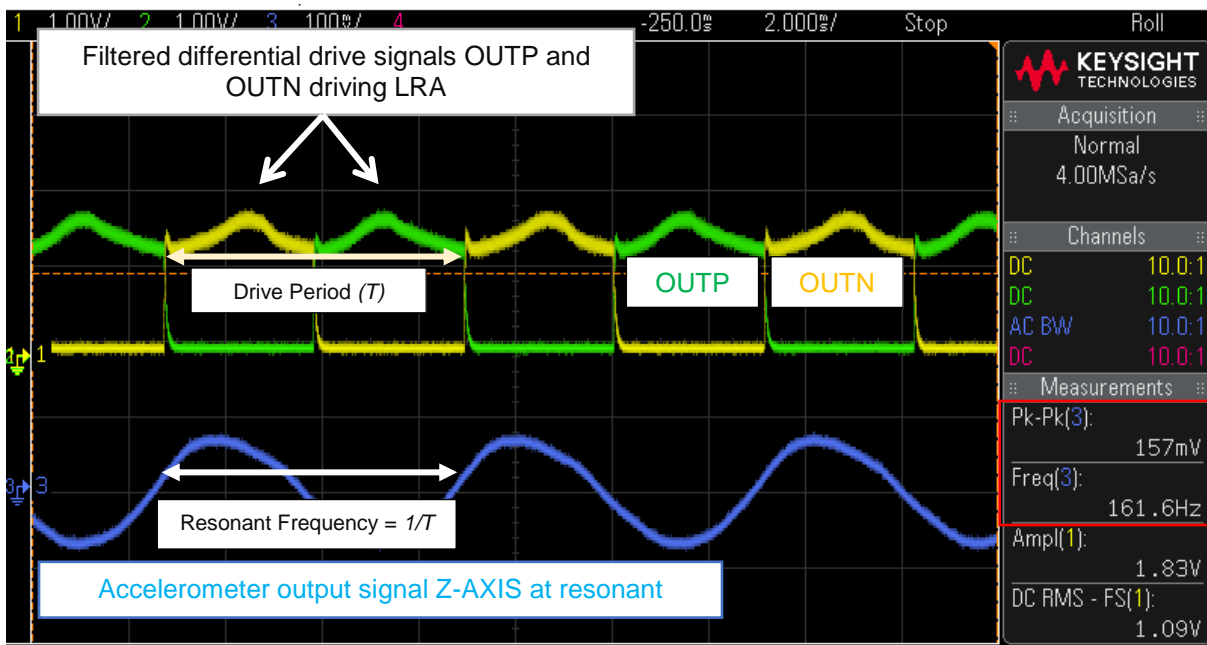

Figure 21: Driving the LRA in DRO Mode

Change the **Operation Mode** to **Inactive** and capture on the oscilloscope the stopping performance of the LRA. The OUTP and OUTN signals stop switching and the LRA slowly stops oscillating. This is the normal behavior without **Rapid Stop** enabled (Figure 22).



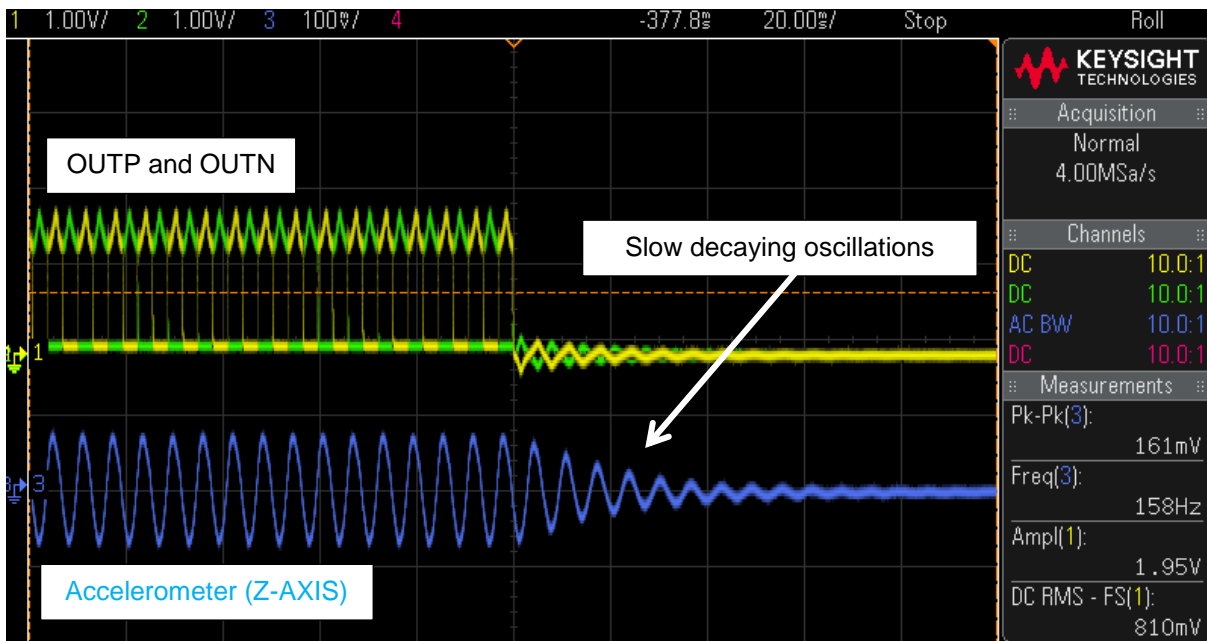

Figure 22: No Rapid Stop Performance

### 5.14 Tuning Rapid Stop Performance

Rapid Stop is the automatic algorithm inside DA7280 used to quickly stop an LRA. Depending on the chosen LRA, it might require additional tuning to optimize the stop performance. Please follow the procedure below for the tuning:

1. Enable **Rapid Stop** in the SmartCanvas DA728x GUI (Figure 23).

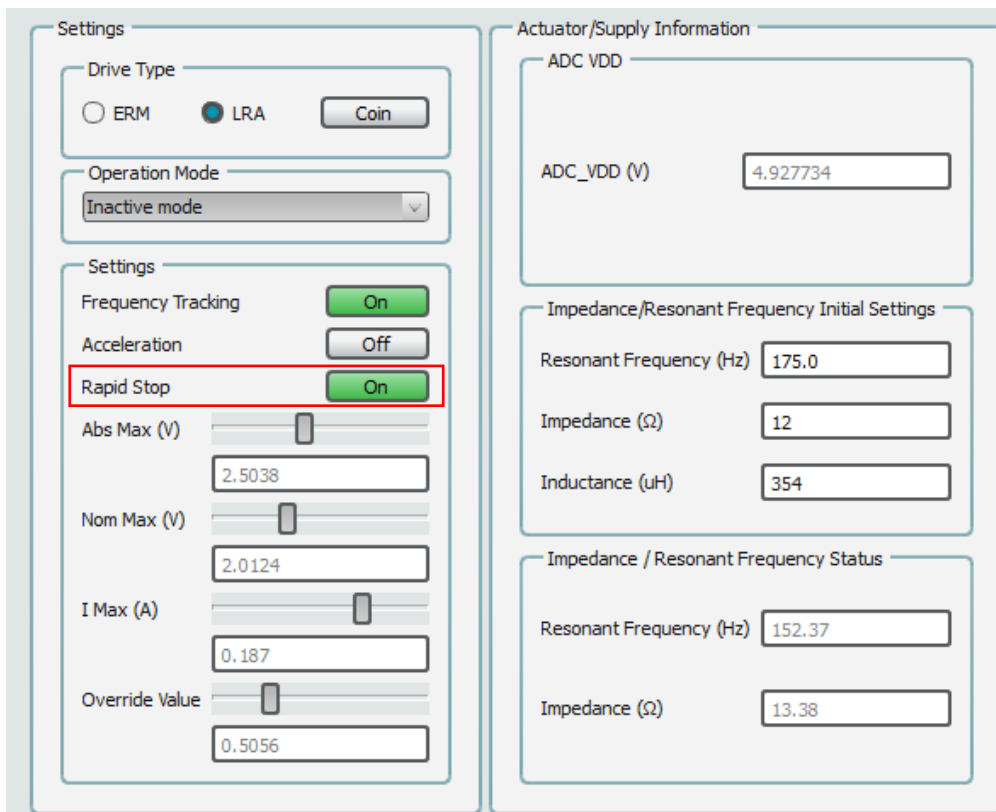

Figure 23: Enabling Rapid Stop in SmartCanvas DA728x GUI



2. Set the Rapid Stop threshold at which DA7280 stops driving while braking in the field **TST\_AMP\_RAPID\_STOP\_LIM** in the register **TOP\_INT\_CFG8** (Figure 24). This register is in the TOP tab of the GUI or can be found using the search box in the GUI at the bottom of the screen. The rapid stop threshold mechanism is based on BEMF sensing and a higher register value corresponds to a higher BEMF voltage threshold.

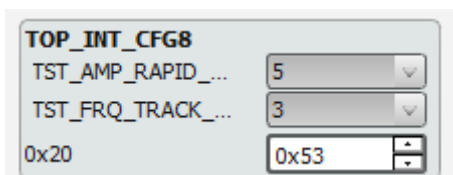

Figure 24: TOP\_INT\_CFG8

3. To test different values for **TST\_AMP\_RAPID\_STOP\_LIM** follow the steps below:
  - a. Set **TST\_AMP\_RAPID\_STOP\_LIM** to 3
  - b. Enable DRO mode
  - c. Setup oscilloscope to capture the stopping performance
  - d. Switch from DRO mode to Inactive Mode which will stop using rapid stop
  - e. Observe capture of stopping on oscilloscope checking the performance of accelerometer signal
  - f. Increase value of **TST\_AMP\_RAPID\_STOP\_LIM** by one (up to the value of 5 maximum) and repeat from step b

An ideal setup has the least amount of ringing and the quickest settling time within a window of around 20 ms after the Rapid Stop feature is turned on.

Note that **TST\_AMP\_RAPID\_STOP\_LIM** value should always be equal or greater than the value of **TST\_FREQ\_TRACK\_BEMF\_LIM**.

From the OOTP and OUTN (the green and yellow) signals shown in Figure 25, we can see that:

- The voltage level for the last two half-periods of the drive signal has increased.
- The drive signal phase has reversed. Instead of another OUTN signal (yellow signal) following the OOTP (green signal), the device actually gets another OOTP (green signal) after the OOTP.

Judging by the acceleration profile (blue trace) in Figure 25, the period after the rapid stop feature is used is defined as the “**20 ms stop window**”. In this period, ideally the following behavior should show up:

- Low ringing
- Fast settling to very low residual oscillations of the LRA

As explained above, In Figure 25 we can see that the stopping performance within the 20 ms stop window is poor, because the Rapid Stop threshold (**TST\_AMP\_RAPID\_STOP\_LIM** = 3) is too low and the stopping continues for too long.

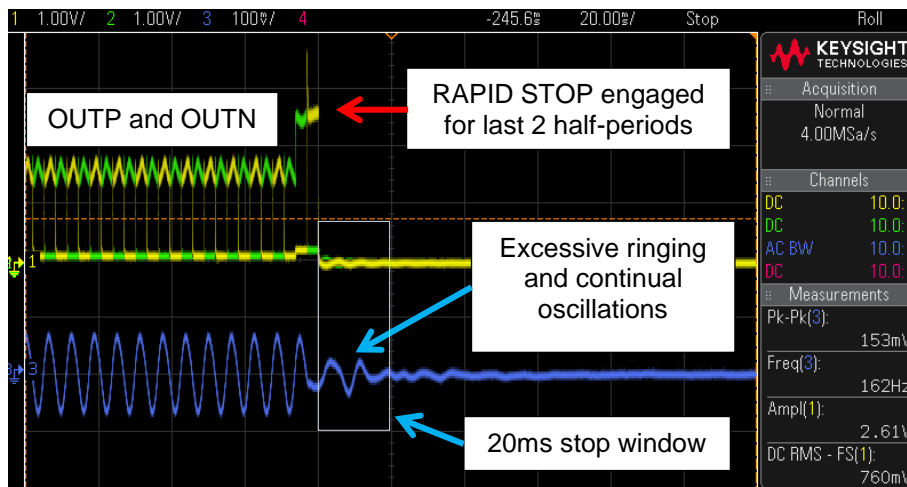

Figure 25:TST\_AMP\_RAPID\_STOP\_LIM Set to 3 - oscillations after stopping

**Setting TST\_AMP\_RAPID\_STOP\_LIM=4**

Acceleration profile below shows a very good stop performance with the LRA being stopped in less than 10 ms. The residual ringing lasts less than 20 ms after the rapid stop is engaged.

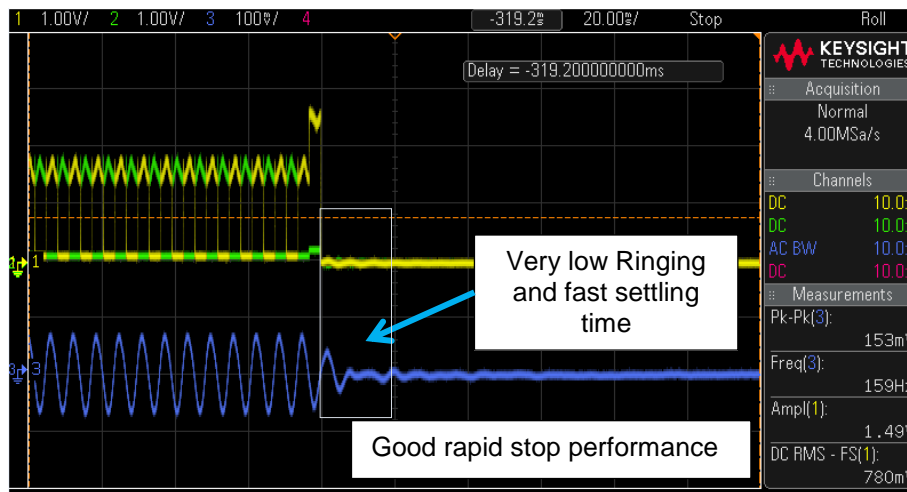

Figure 26:TST\_AMP\_RAPID\_STOP\_LIM = 4 - fast settling time

Please note that when the stop performance is being tuned with Rapid Stop set to OFF, it is recommended that **TST\_AMP\_RAPID\_STOP\_LIM** register in **TOP\_INT\_CFG8** should be set to 7

**5.15 Save All Registers**

After the device registers have been tuned and its registers are ready to be saved for future operations, the desired startup mode should be set using the SmartCanvas DA728x GUI as the register state will be used as a script for this LRA configuration. For example, if the register triggered waveform memory is the required default startup when the script is loaded, set the operation mode to “register triggered waveform memory” in the SmartCanvas DA728x GUI before saving the registers.

Similarly, if an edge triggered startup is required for the startup script, select the “edge triggered waveform memory” as the operation mode and configure the GPI registers with the desired setting under the **SYSTEM** tab in the SmartCanvas DA728x GUI before saving them. In this way, when the script is loaded again via the SmartCanvas DA728x GUI or incorporated into an embedded system, the correct register settings are already in place.

Ensure that the Kp and Ki settings are the same as tuned in section 5.9.

Make sure the LRA is not being driven, now re-enter the resonant frequency, impedance, and inductance values in the SmartCanvas DA728x GUI. These should still be what was originally entered at the start of the tuning process, the quickest way to do this is click on each of the entry box and just press return on the value. Note: it is important to always press ENTER on the keyboard after filling in each value as this ensures that the value is programmed into the register.

This process ensures that the default mean value from the datasheet are used as a starting point when the script is loaded and not the values that were measured and stored when driving the specific LRA being tested which may not be at the datasheet mean values.

Now the setup script for LRA and tuning work done so far is ready to be saved. Select "**Save All Registers**" in the SmartCanvas DA728x GUI as shown in [Figure 27](#) so that the setup script for the tuned LRA is saved. The **File Format** can be **Number** or **Name**, whereby either the register number or the register name is saved to the file.

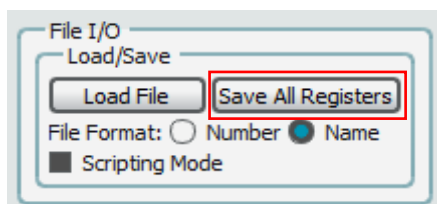

Figure 27: Save All Registers

## Appendix A Searching for Registers in the SmartCanvas DA728x GUI

To easily find a register, simply enter the register name in the **Search Widget** in the GUI. Select **All Text** and press **Find Button** (Figure 28).

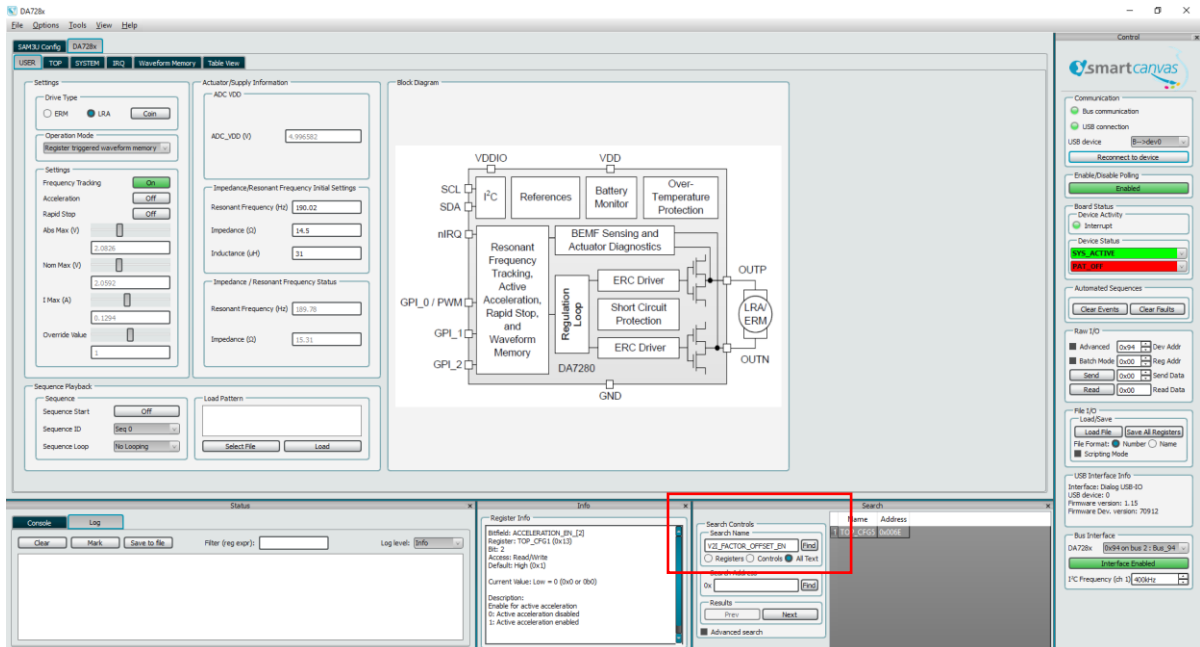

Figure 28: Search Widget in SmartCanvas DA728x GUI

## Appendix B Notes on Using the Acceleration Feature

- If Acceleration is enabled, V2I\_FACTOR\_OFFSET\_EN should also be enabled, so that a 50 mV offset is applied to the V2I factor calculation.
- If Acceleration is disabled, V2I\_FACTOR\_OFFSET\_EN should be disabled and no offset is applied to the V2I factor calculation.

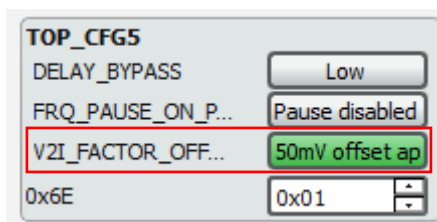

Figure 29: Setting V2I\_FACTOR\_OFFSET\_EN in SmartCanvas DA728x GUI

- MEM\_DATA\_SIGNED needs to be set according to the value of ACCELERATION\_EN. The SmartCanvas DA728x GUI automatically sets this bit:
  - 0: unsigned (for ACCELERATION\_EN = 1)
  - 1: signed (for ACCELERATION\_EN = 0)

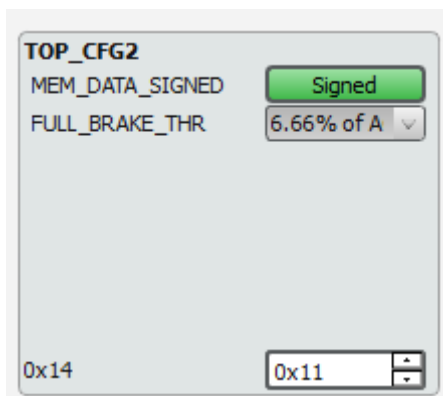

Figure 30: MEM\_DATA\_SIGNED Bit

## Appendix C Overdriving the LRA

The ABS\_MAX can be increased to drive the LRA beyond the datasheet values, especially for cases of very short waveforms such as clicks. Please consult with the LRA manufacturer about the reliability concerns regarding overdriving voltages.

### C.1 Acceleration Enabled

If ACCELERATION\_EN = 1, the automatic algorithm in DA7280 will overdrive the LRA for short periods of time to the increased ABS\_MAX level and transition between drive levels to speed up the mechanical response of the actuator before dropping to NOM\_MAX or below (based on the drive level set via the DRO/PWM/Waveform memory input).

### C.2 Acceleration Disabled

If ACCELERATION\_EN = 0, the drive level sent via the input (DRO/PWM/WM) will scale directly to ABS\_MAX. Should the user require to overdrive above the LRA datasheet parameters, the timing is fully controlled by the user.

### C.3 Rapid Stop OFF

When Rapid Stop is set to OFF, it is recommended that the TST\_AMP\_RAPID\_STOP\_LIM register in TOP\_INT\_CFG8 should be set to 7.

### C.4 Compensating for the BEMF

ABS\_MAX and NOM\_MAX are based on the  $I \times R$  drop across the actuator and do not factor in the BEMF voltage amplitude (which is usually negligible). If the customer requires no overshoot above the specified datasheet value, the following procedure can be followed:

1. Do the initial setup as specified in this document
2. Drive at full scale DRO value of 1.0.
3. Observe the filtered down OUTP or OUTN voltage on the scope
4. Scale back ABS\_MAX until the voltage is below the datasheet parameter
5. Update the saved script using the new ABS\_MAX value

The process for setting up a 2 V maximum voltage drive including the BEMF is shown in [Figure 31](#).

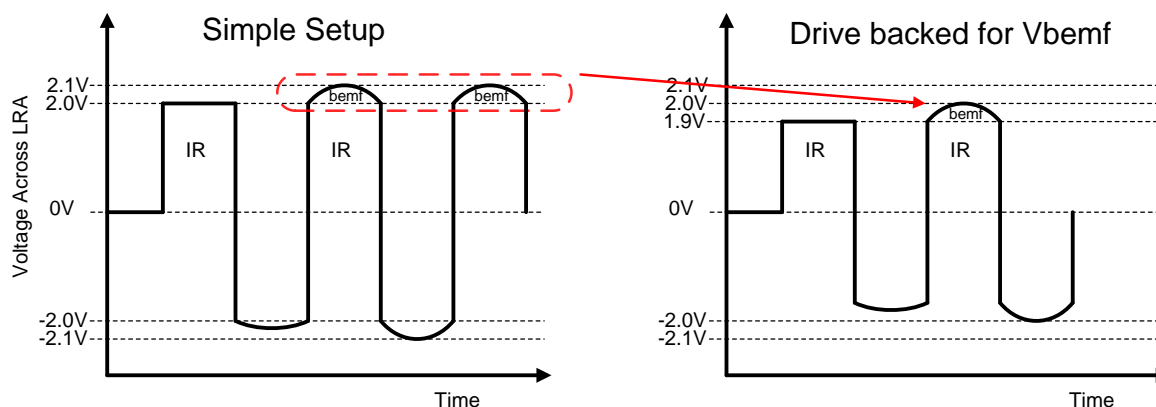

Figure 31: Scaling Back Drive for Nominal 2 V Output

## Appendix D VDD Margin

VDD\_MARGIN is a register that determines the space in the voltage domain between the output by the actuator and the supply. This is important because DA7280 is a current-loop controlled driver and if it runs out of voltage headroom, the system will stop regulating current, which in turn negatively impacts all the closed loop algorithms. VDD\_MARGIN is programmable in steps of 187.5 mV, where 0 is 0 V margin, 1 is 187.5 mV margin, and so on. It needs to be greater than the combined values of the BEMF, IR drop across the power FETs, and the limit imposed by the maximum duty cycle.

Constants:

- Usual maximum impedance of the H-bridge: 2  $\Omega$
- Maximum duty cycle: 93%
- BEMF rule-of-thumb: 100 mV to 200 mV (needs to be checked on the specific actuator at the maximum nominal settings)

A VDD margin example calculation using an LRA actuator with 140 mA  $I_{max}$ , 160 mV BEMF, and 24  $\Omega$  impedance is shown below:

- IR drop is  $140 \text{ mA} \times 2 \Omega = 280 \text{ mV}$
- At 3.8 V, the maximum duty cycle of 93% means that DA7280 cannot drive the LRA at the top  $0.07 \times 3.8 = 266 \text{ mV}$  (3.8 V is selected as it is the realistic value where the device is expected to start infringing on the limit)
- BEMF is about 160 mV
- All in all, the needed margin is  $280 \text{ mV} + 266 \text{ mV} + 160 \text{ mV} = 706 \text{ mV}$
- The closest setting to that is VDD\_MARGIN = 4, which gives  $4 \times 187.5 = 750 \text{ mV}$

### NOTE

It is advisable to sweep VDD over its expected range with DRO set at 1 and observe the voltage across the LRA for instabilities. Should instabilities be present, increase the VDD\_MARGIN value.

## Appendix E Calculating Resonant Frequency

To set resonant/drive frequency to 155 Hz, the following is an example python code for calculating the register values for LRA\_PER\_H/L.

```
FREQ_TAGRET = 155
value = int (1 / (FREQ_TAGRET * (1333.32 * 10 * -9)))
LRA_PER_H = (value >> 7) & 0xFF
LRA_PER_L = value & 0x7F
```

The calculated values are:

- LRA\_PER\_H = 0x25
- LRA\_PER\_L = 0x66

## Appendix F Notes for Driving with PWM

- When the LRA is driven with a PWM input signal, ensure that the PWM input signal is applied before the driver is switched from idle to PWM input mode. If this sequence is not followed, an IRQ fault will be triggered.
- When the driver exits the PWM input mode, ensure that the PWM input signal is still being driven before the driver exits the PWM input mode and returns to idle. If this sequence is not followed, an IRQ fault will be triggered.
- When the driver exits PWM mode, it is recommended that the PWM drive signal is first brought down to below the PWM brake threshold level (FULL\_BRAKE\_THR value in TOP\_CFG2). This ensures that the output pulses from the driver stop before the device enters idle mode. If this procedure is not done, a single output pulse from the device may be seen on P or N outputs when the device re-enters PWM mode even though PWM input signal may be below the brake threshold level. This is due to the last PWM level being stored in a memory buffer of the device when the output is stopped abruptly without first reducing the PWM input into the brake threshold region. This last PWM level is then clocked out from the device when the PWM mode is restarted.
- Please note that the PWM signal should always be present when the LRA is driven in PWM mode, for example, the signal cannot be 100% 1's or 100% 0's for any time longer than the lowest allowed PWM input clock (10KHz). If the PWM input signal is at 1 or 0 for longer than this period, then this is regarded as a loss of PWM input signal and will result in an IRQ fault.

## Appendix G Specific Register Details

The SmartCanvas DA728x GUI can save the entire register map after tuning of the LRA is complete. The saved file contains the entire register map's state, but quite a few of these registers are status registers, trim registers, and registers set at their default values.

For each tuning of an LRA, the important registers and mode setup registers are highlighted in the following appendixes to help users encode a simple driver script.

### G.1 Tuned Registers Applicable for Every LRA

- Voltage and current settings are unique to each LRA: check the LRA datasheet.
  - address=0x0d // ABS\_MAX
  - address=0x0c // NOM\_MAX
  - address=0x0e // IMAX
- Enter resonance frequency in the SmartCanvas DA728x GUI, hit ENTER on the keyboard, and the following registers are automatically updated. Also see [Appendix E](#).
  - address=0x0a // LRA\_PER\_H
  - address=0x0b // LRA\_PER\_L
- Enter impedance in the SmartCanvas DA728x GUI, hit ENTER on the keyboard after entering the value. The following registers are updated (the GUI uses a calculation to generate the values).
  - address=0x0f // CALIB\_V2I\_H
  - address=0x10 // CALIB\_V2I\_L
- Enter inductance in the SmartCanvas DA728x GUI, hit ENTER on the keyboard, the GUI references a lookup table for FILT RES/CAP indicated by the LRA datasheet, and the following



registers are automatically updated. Please note that the value in the impedance entry is also used for this calculation, please refer to section 5.7.9 in the datasheet.

- address=0x60 // TRIM4 LOOP FILT CAP RES
- Run the LRA Tuning Tool to get the following values. See section 5.9.
  - address=0x1c // KP\_H
  - address=0x1d // KP\_L
  - address=0x1e // KI\_H
  - address=0x1f // KI\_L
- Tune the Rapid Stop performance and choose a sensible value. See section 5.14.
  - address=0x20 // TOP\_INT\_CFG8
- FRQ\_LOCKED\_LIM value selection, this value is used to determine the limit for the generation of frequency locked signal which is used to enable rapid stop. Keep this value high for nonlinear LRAs if Rapid Stop is enabled. If Rapid Stop is not used, no action on this register is needed.
  - address=0x17 // TOP\_INT\_CFG1

## G.2 Mode and Configuration Registers that can Be Changed Dynamically

- Set operation mode depending on what is required.
  - address=0x22 // Operation Mode
  - If DRO mode is used, the following register changes the drive level.
    - address=0x23 // Override value
- The GPI trigger registers: These assign Waveform Memory Sequences to GPI triggers.
  - address=0x29 // GPI\_0\_CTL
  - address=0x2A // GPI\_1\_CTL
  - address=0x2B // GPI\_2\_CTL
  - The following register allows looping of waveform memory sequences.
    - address=0x28 // SEQ\_CTL2
  - The following register determines the time base of Waveform Memory Sequences, sets the output to drive sine or square waves, and controls back-to-back Waveform Memory Sequences triggered by the register triggered mode or the edge triggered mode.
    - address=0x24 // SEQ\_CTL1
- The main configuration register: check the SmartCanvas DA728x GUI for details.
  - address=0x13 // TOP\_CFG1
  - The SmartCanvas DA728x GUI updates MEM\_DATA\_SIGNED and V2I\_FACTOR\_OFFSET\_EN automatically, depending on whether Acceleration is enabled or disabled.
    - address=0x14 // TOP\_CFG2
    - address=0x6E // TOP\_CFG5, V2I\_FACTOR\_OFFSET\_EN\_[0]
    - If MEM\_DATA\_SIGNED is set to Unsigned (when acceleration is ON), V2I\_FACTOR\_OFFSET\_EN should be set to 1.
    - If MEM\_DATA\_SIGNED is set to Signed (when acceleration is OFF), V2I\_FACTOR\_OFFSET\_EN should be set to 0.
- Clearing faults:
  - address=0x03 // IRQ\_EVENT1
  - address=0x81 // IRQ\_EVENT\_ACTUATOR\_FAULT
  - For LRAs with a low BEMF, set BEMF\_FAULT\_LIM to BEMF\_FAULT\_DISABLED to avoid IRQs.

– Address=017 // TOP\_INT\_CFG1, BEMF\_FAULT\_LIM\_[0]

### G.3 Diff'ing Files

Another useful method of generating a list of the important registers to create an optimal script is as follows:

1. After the device starts up and gets connected to a PC via USB
2. Save the register contents to a file and call it “defaults” (it includes the register state of the device after POR).
3. Using a standard text editor and the diff function to compare the LRA Configuration Script generated from the tuning of the LRA with the “defaults” file to see the register differences. Any status or IRQ registers need not be programmed.
4. This results in an optimal script which only contains the I2C writes needed to set up the device in the desired mode.

### Revision History

Revision	Date	Description
1.1	08-Jun-2022	Rebranded to Renesas.
1.0	04-Nov-2019	Initial version.

**Status Definitions**

Status	Definition
DRAFT	The content of this document is under review and subject to formal approval, which may result in modifications or additions.
APPROVED or unmarked	The content of this document has been approved for publication.

### Important Notice and Disclaimer

RENESAS ELECTRONICS CORPORATION AND ITS SUBSIDIARIES ("RENESAS") PROVIDES TECHNICAL SPECIFICATIONS AND RELIABILITY DATA (INCLUDING DATASHEETS), DESIGN RESOURCES (INCLUDING REFERENCE DESIGNS), APPLICATION OR OTHER DESIGN ADVICE, WEB TOOLS, SAFETY INFORMATION, AND OTHER RESOURCES "AS IS" AND WITH ALL FAULTS, AND DISCLAIMS ALL WARRANTIES, EXPRESS OR IMPLIED, INCLUDING, WITHOUT LIMITATION, ANY IMPLIED WARRANTIES OF MERCHANTABILITY, FITNESS FOR A PARTICULAR PURPOSE, OR NON-INFRINGEMENT OF THIRD PARTY INTELLECTUAL PROPERTY RIGHTS.

These resources are intended for developers skilled in the art designing with Renesas products. You are solely responsible for (1) selecting the appropriate products for your application, (2) designing, validating, and testing your application, and (3) ensuring your application meets applicable standards, and any other safety, security, or other requirements. These resources are subject to change without notice. Renesas grants you permission to use these resources only for development of an application that uses Renesas products. Other reproduction or use of these resources is strictly prohibited. No license is granted to any other Renesas intellectual property or to any third party intellectual property. Renesas disclaims responsibility for, and you will fully indemnify Renesas and its representatives against, any claims, damages, costs, losses, or liabilities arising out of your use of these resources. Renesas' products are provided only subject to Renesas' Terms and Conditions of Sale or other applicable terms agreed to in writing. No use of any Renesas resources expands or otherwise alters any applicable warranties or warranty disclaimers for these products.

© 2022 Renesas Electronics Corporation. All rights reserved.

(Rev.1.0 Mar 2020)

## Corporate Headquarters

TOYOSU FORESIA, 3-2-24 Toyosu

Koto-ku, Tokyo 135-0061, Japan

[www.renesas.com](http://www.renesas.com)

### Contact Information

For further information on a product, technology, the most up-to-date version of a document, or your nearest sales office, please visit:

<https://www.renesas.com/contact/>

### Trademarks

Renesas and the Renesas logo are trademarks of Renesas Electronics Corporation. All trademarks and registered trademarks are the property of their respective owners.

## IMPORTANT NOTICE AND DISCLAIMER

RENESAS ELECTRONICS CORPORATION AND ITS SUBSIDIARIES (“RENESAS”) PROVIDES TECHNICAL SPECIFICATIONS AND RELIABILITY DATA (INCLUDING DATASHEETS), DESIGN RESOURCES (INCLUDING REFERENCE DESIGNS), APPLICATION OR OTHER DESIGN ADVICE, WEB TOOLS, SAFETY INFORMATION, AND OTHER RESOURCES “AS IS” AND WITH ALL FAULTS, AND DISCLAIMS ALL WARRANTIES, EXPRESS OR IMPLIED, INCLUDING, WITHOUT LIMITATION, ANY IMPLIED WARRANTIES OF MERCHANTABILITY, FITNESS FOR A PARTICULAR PURPOSE, OR NON-INFRINGEMENT OF THIRD-PARTY INTELLECTUAL PROPERTY RIGHTS.

These resources are intended for developers who are designing with Renesas products. You are solely responsible for (1) selecting the appropriate products for your application, (2) designing, validating, and testing your application, and (3) ensuring your application meets applicable standards, and any other safety, security, or other requirements. These resources are subject to change without notice. Renesas grants you permission to use these resources only to develop an application that uses Renesas products. Other reproduction or use of these resources is strictly prohibited. No license is granted to any other Renesas intellectual property or to any third-party intellectual property. Renesas disclaims responsibility for, and you will fully indemnify Renesas and its representatives against, any claims, damages, costs, losses, or liabilities arising from your use of these resources. Renesas' products are provided only subject to Renesas' Terms and Conditions of Sale or other applicable terms agreed to in writing. No use of any Renesas resources expands or otherwise alters any applicable warranties or warranty disclaimers for these products.

(Disclaimer Rev.1.01 Jan 2024)

### Corporate Headquarters

TOYOSU FORESIA, 3-2-24 Toyosu,  
Koto-ku, Tokyo 135-0061, Japan  
[www.renesas.com](http://www.renesas.com)

### Trademarks

Renesas and the Renesas logo are trademarks of Renesas Electronics Corporation. All trademarks and registered trademarks are the property of their respective owners.

### Contact Information

For further information on a product, technology, the most up-to-date version of a document, or your nearest sales office, please visit [www.renesas.com/contact-us/](http://www.renesas.com/contact-us/).