

Restrictions:

IDT's ZSPM8035-KIT Evaluation Kit hardware and the Pink Power Designer™ software are designed only for evaluation of the ZSPM1035A PWM Controller IC and the Murata OKLP-X/35-W12-C Power Block; laboratory setup; and module development. The kit hardware and software must not be used for module production and production test setups.

IDT shall not be liable for any damages arising out of defects resulting from (i) delivered hardware and software, (ii) non-observance of instructions contained in this manual, or (iii) misuse, abuse, use under abnormal conditions, or alteration by anyone other than IDT. To the extent permitted by law, IDT hereby expressly disclaims and User expressly waives any and all warranties, whether express, implied, or statutory, including, without limitation, implied warranties of merchantability and of fitness for a particular purpose, statutory warranty of non-infringement, and any other warranty that may arise by reason of usage of trade, custom, or course of dealing.



Important Safety Warning: These procedures can result in high currents, which can cause severe injury or death. Only trained professional staff should connect external equipment. Ensure that all staff have read and understood this document and the high voltage safety disclaimer that is included with the kit.

Contents

- 1 Introduction 3
 - 1.1. Kit Contents 3
- 2 ZSPM8035 Evaluation Board 4
 - 2.1. Evaluation Board Overview 4
 - 2.2. General Setup for the Evaluation System 6
 - 2.2.1. User Instrumentation 7
 - 2.2.2. User Computer 7
- 3 Software Installation and Setup 7
- 4 Pink Power Designer™ Software Overview 8
- 5 Evaluation Kit Setup for a 1.2V Output Voltage 10
- 6 Evaluation Board Hardware and Software Setup 13
 - 6.1. Introduction 13
 - 6.2. Setting the Output Voltage 13
 - 6.3. Output Capacitor Range Selection 14
 - 6.3.1. Output Capacitor Range Test Procedure 15
 - 6.4. On Board Transient Loads 16
- 7 Support 18
- 8 Related Documents 18
- 9 Definitions of Acronyms 18
- 10 Document Revision History 19
- Appendix A: ZSPM8035 Evaluation Board 20
- Appendix B: ZSPM8035 Evaluation Board Schematic 21

List of Figures

Figure 1.1 ZSPM8035-KIT Evaluation Kit Contents 3

Figure 2.1 ZSPM8035-KIT Evaluation Board (Top Side)..... 5

Figure 2.2 ZSPM8035-KIT Evaluation Board (Bottom Side) 6

Figure 2.3 Pink Power Evaluation Kit Setup 6

Figure 4.1 The Pink Power Designer™ GUI 8

Figure 5.1 ZSPM8035-KIT PMBus™CI Connection (Top Side of PCB) 10

Figure 5.2 Pink Power Designer™ Murata Power Block Wizard Button 10

Figure 5.3 Pink Power Designer™ Wizard – Power Block Selection 11

Figure 5.4 Pink Power Designer™ Wizard – Output Voltage Range Selection..... 11

Figure 5.5 Pink Power Designer™ Wizard – Output Capacitor Range Selection 12

Figure 5.6 “Write to Chip” Button 12

Figure 5.7 “Operation CMD” Button 12

Figure 6.1 J107 – Output Voltage Range Hardware Selection..... 14

Figure 6.2 J106 - Output Capacitor Range Hardware Selection 15

Figure 6.3 J100 and J101 – Transient Load Selection 17

Figure 6.4 Timing for the On-Board Transient Loads 17

1 Introduction

This document describes the use of IDT's ZSPM8035-KIT for evaluating DC/DC point-of-load (POL) applications and provides additional kit information, including the circuit diagram and board layout. The kit incorporates IDT's ZSPM1035A digital PWM controller IC and the Murata OKLP-X/35-W12-C Power Block to form a "smart" buck converter (a.k.a. step-down DC-to-DC converter).

The ZSPM8035-KIT Evaluation Kit hardware functions with the ZSPM1035A Pink Power Designer™ graphical user interface (GUI), which is used to configure the ZSPM1035A features and for monitoring the internal measurements and fault conditions of the ZSPM1035A. The GUI software must be downloaded to the user's PC from the IDT website to ensure receiving the latest release as described in section 3. See section 2.2.2 for the requirements for the user's PC.

The PMBus™ Communication Interface (CI) provides the interface between the ZSPM8035-KIT Evaluation Kit and the user's PC.

1.1. Kit Contents

- ZSPM8035 Evaluation Board
- PMBus™ Communication Interface (CI)
- USB Cable
- *Startup Information* document
- *Safety Disclaimer* document

Figure 1.1 ZSPM8035-KIT Evaluation Kit Contents

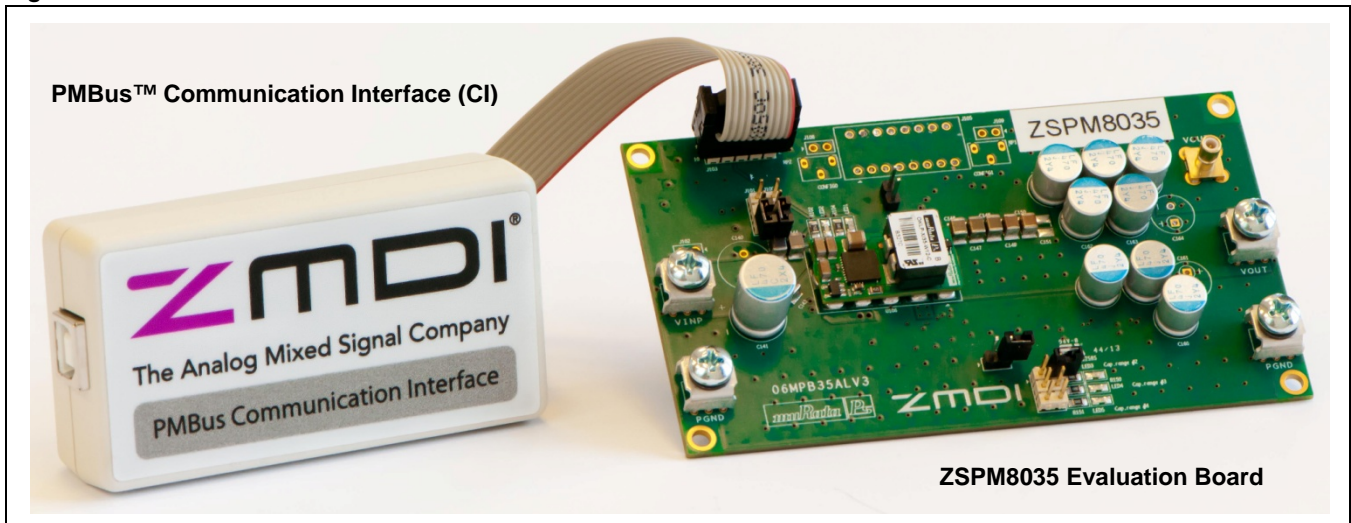

2 ZSPM8035 Evaluation Board

2.1. Evaluation Board Overview

The ZSPM8035 Evaluation Kit provides all the necessary components for a first evaluation of IDT's ZSPM1035A digital PWM controller. The ZSPM1035A can be configured in the Pink Power Designer™ Graphical User Interface (GUI).

In addition to the ZSPM1035A controller, the Evaluation Board features the Murata OKLP-X/35-W12-C Power Block. The number of output capacitors can be selected with a jumper on the Evaluation Board. The electrical specifications can be found in Table 2.1, and the schematic is provided in Appendix B.

Table 2.1 Key Design Parameters for the Evaluation Kit Power Stage

Parameter	Value
Input voltage	7 – 13.2V
Output voltage	0.6 to 1.2V or 1.2 to 3.6V
Maximum output current	35A*
Switching frequency	500kHz
* The Murata OKLP-X/35-W12-C Power Block has an output power limitation of 82.5W. The maximum output current is therefore a function of the output voltage.	

The board also provides the connections needed for digital communication between the ZSPM1035A and the GUI software via the PMBus™ Communications Interface (CI).

An on-board transient load is also provided for generating load transients with high current slew rates.

Figure 2.1 shows the ZSPM8035 Evaluation Board and the board connections that will be completed in the subsequent setup steps. Do not make the connections at this point.

Figure 2.1 ZSPM8035-KIT Evaluation Board (Top Side)

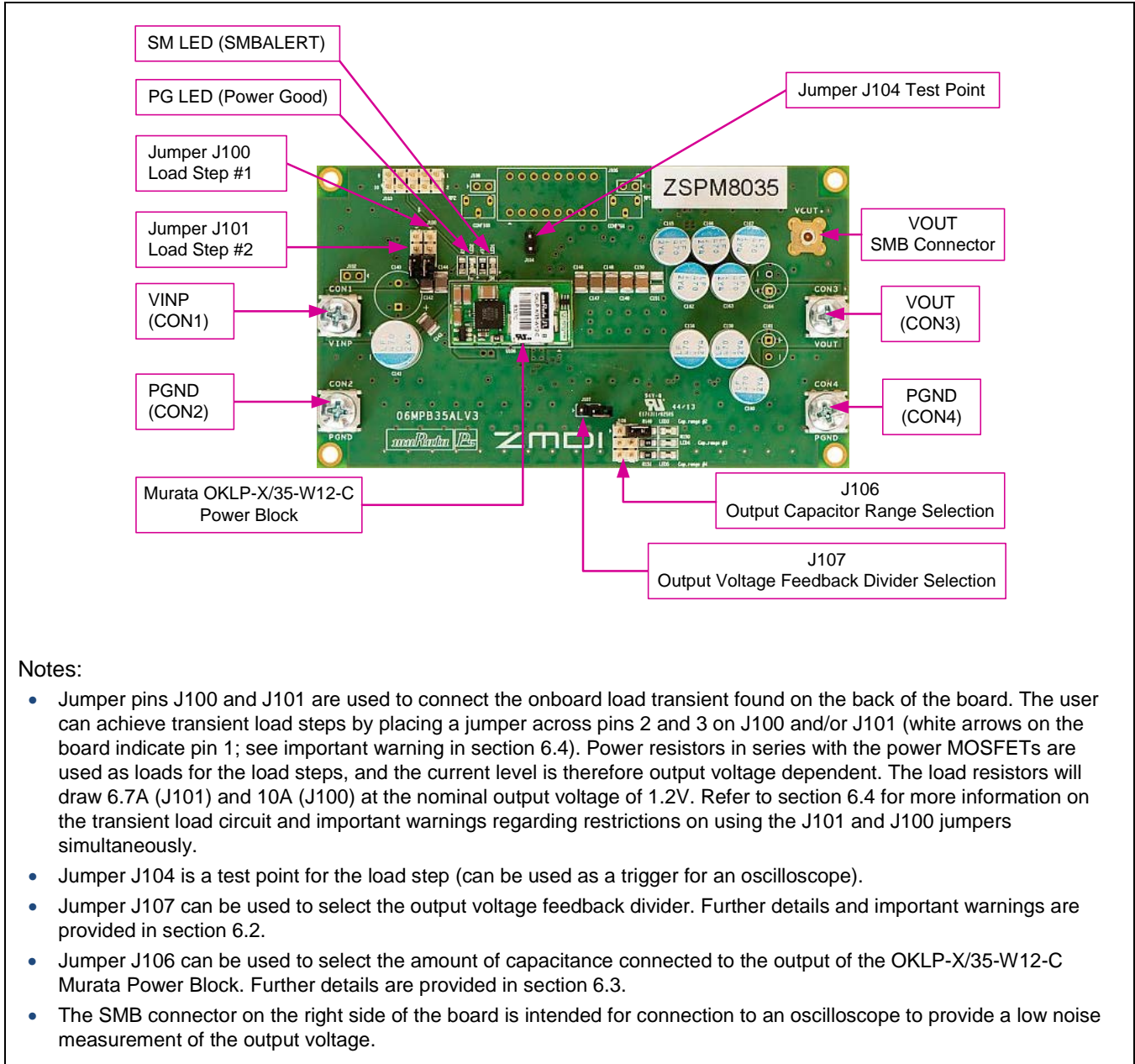

Notes:

- Jumper pins J100 and J101 are used to connect the onboard load transient found on the back of the board. The user can achieve transient load steps by placing a jumper across pins 2 and 3 on J100 and/or J101 (white arrows on the board indicate pin 1; see important warning in section 6.4). Power resistors in series with the power MOSFETs are used as loads for the load steps, and the current level is therefore output voltage dependent. The load resistors will draw 6.7A (J101) and 10A (J100) at the nominal output voltage of 1.2V. Refer to section 6.4 for more information on the transient load circuit and important warnings regarding restrictions on using the J101 and J100 jumpers simultaneously.
- Jumper J104 is a test point for the load step (can be used as a trigger for an oscilloscope).
- Jumper J107 can be used to select the output voltage feedback divider. Further details and important warnings are provided in section 6.2.
- Jumper J106 can be used to select the amount of capacitance connected to the output of the OKLP-X/35-W12-C Murata Power Block. Further details are provided in section 6.3.
- The SMB connector on the right side of the board is intended for connection to an oscilloscope to provide a low noise measurement of the output voltage.

Figure 2.2 ZSPM8035-KIT Evaluation Board (Bottom Side)

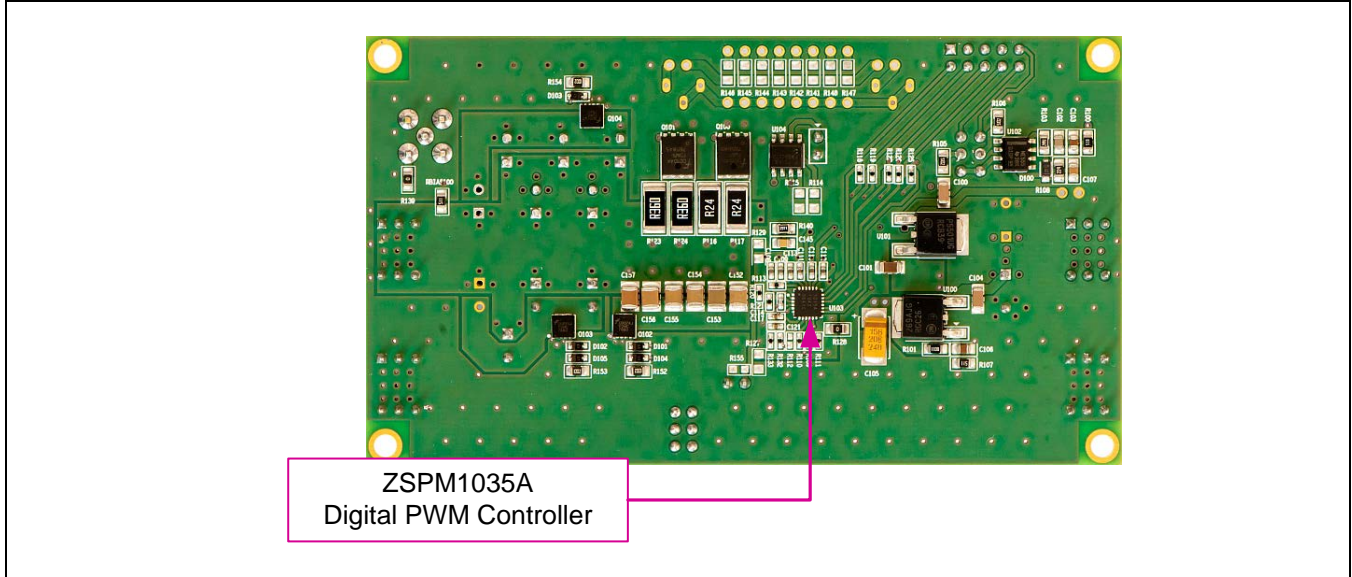

2.2. General Setup for the Evaluation System

The basic setup for using the ZSPM8035 Evaluation Kit is illustrated in Figure 2.3. The pink shaded blocks and the USB cable are the kit.

Figure 2.3 Pink Power Evaluation Kit Setup

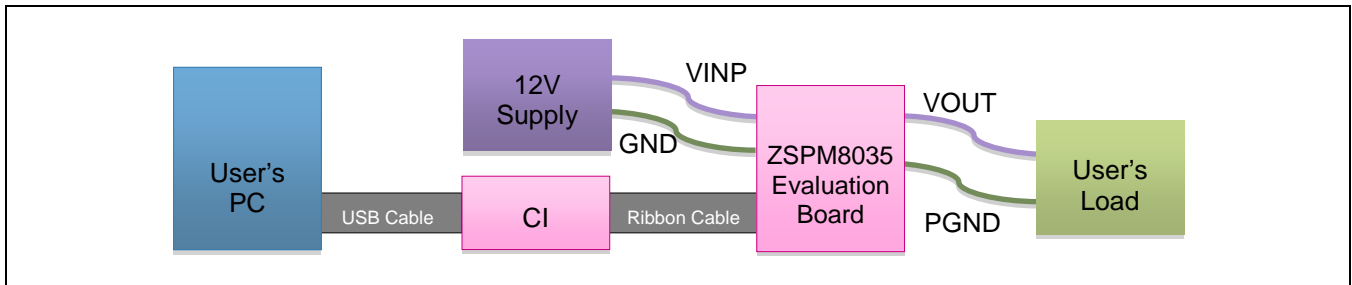

2.2.1. User Instrumentation

The following user equipment is required or recommended for demonstrating the features of the ZSPM1035A controller and the Murata OKLP-X/35-W12-C with the Evaluation Kit:

- **DC power supply:** An external power supply is required for the ZSPM8035 Evaluation Board. Its output voltage should be at least 12V with a rated output current of approximately 1A to 8A depending on the test conditions.
- **Electronic load:** An external DC load is highly recommended as the Evaluation Board features only transient loads due to constraints on power dissipation. While an electronic load can be very advantageous, load resistors could also be sufficient for testing. Ensure that the electronic load has an adequate power rating.
- **Oscilloscope:** Connecting an oscilloscope to the Evaluation Kit is strongly recommended for measuring the performance of the Evaluation Board in the time domain. The Evaluation Board features an SMB connector connected to the output of the power stage for easy connection to an oscilloscope.

2.2.2. User Computer

A Windows®-based computer (PC) is required for interfacing with the ZSPM8035 Evaluation Board through the PMBus™ Communication Interface. The user will need administrative rights on the PC to download and install the Pink Power Designer™ GUI for the kit. The PC must meet the following requirements:

- Windows® XP or Windows® 7
- Internet access

3 Software Installation and Setup

The software for the ZSPM8035 KIT is the ZSPM1035A Pink Power Designer™ graphical user interface (GUI), which is required to configure the ZSPM1035A and monitor the internal measurement and fault conditions of the ZSPM1035A. The Pink Power Designer™ must be downloaded from the ZSPM1035A product page on IDT's website: www.IDT.com/ZSPM1035A.

1. Click on this link on the ZSPM1035A product page to download the zip file for the GUI: **Pink Power Designer(TM) GUI for ZSPM1035A Rev. X.x.y**. (X.x.y refers to the latest version of the file.)
2. Extract the executable file *ZMDI_ZSPM1035A_PPDGui_X.x.y_win32-setup.exe* from the zip file.
3. Install the Pink Power Designer™ GUI software by clicking on the extracted file *ZMDI_ZSPM1035A_PPDGui_X.x.y_win32-setup.exe*.

4 Pink Power Designer™ Software Overview

This section gives a brief introduction to the Pink Power Designer™ software. For full instructions for using the software, refer to the *Pink Power Designer™ Graphic User Interface (GUI) for the ZSPM1035A*, which is included in the software and can also be downloaded from the ZSPM1035A product page on IDT's web site (www.IDT.com/ZSPM1035A). To open it from within the GUI, click “Help” on the top menu of the Pink Power Designer™ GUI and then click “User Guide” (see Figure 4.1).

The Pink Power Designer™ is a graphical user interface (GUI) designed by IDT to enable the user to configure the device and monitor the internal measurements and fault conditions on the evaluation or application board. The Pink Power Designer™ GUI includes a wizard that will guide the user through a simple selection process to select the output voltage and output capacitance. The display is structured with a main window and a side panel on the left side for status information.

Figure 4.1 The Pink Power Designer™ GUI

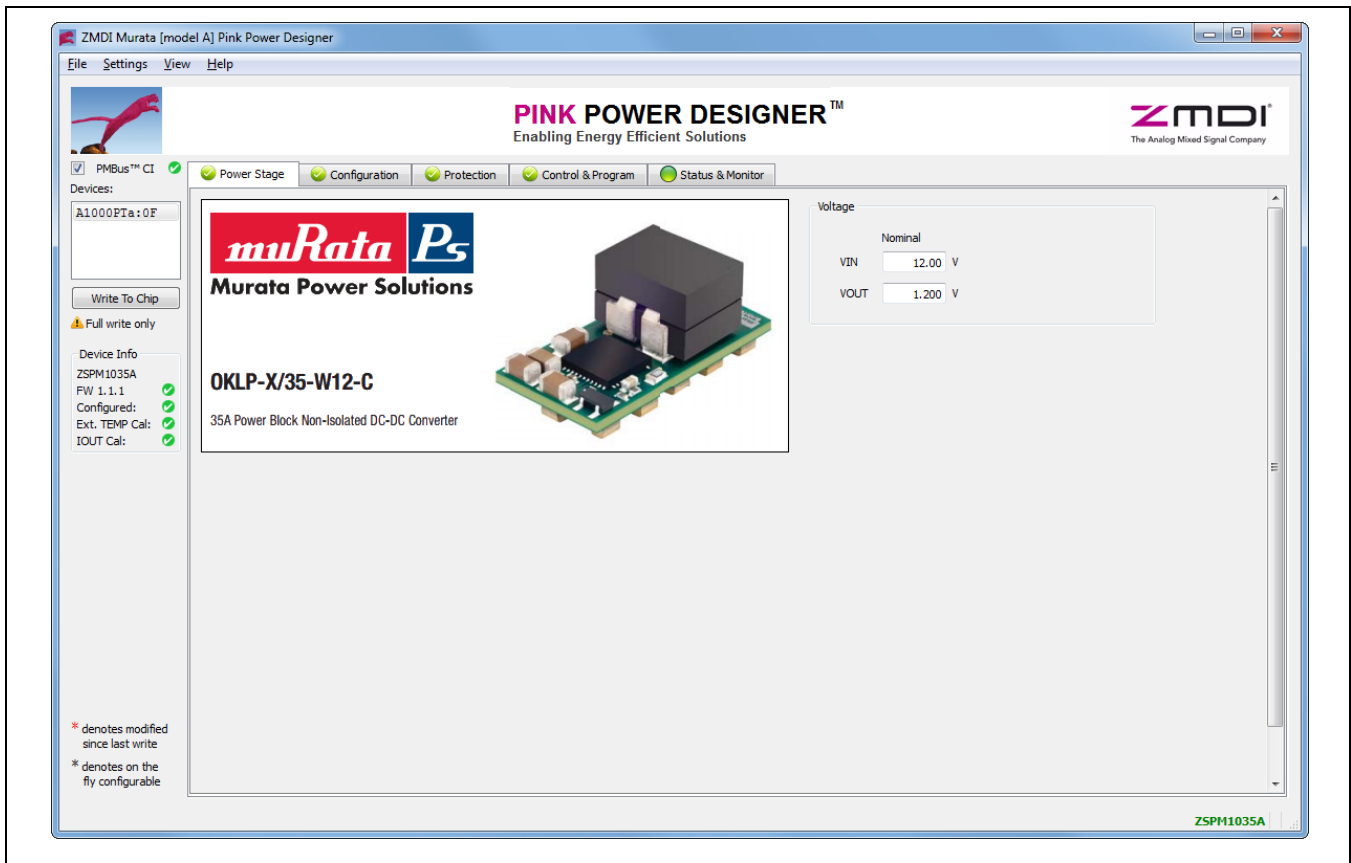

The “Murata Power Block” Wizard

Upon start-up of the GUI, a wizard will guide the user through a simple selection process. The wizard will select the correct configuration data for the ZSPM1035A controller. The wizard can also be invoked within the GUI by selecting “New” in the “File” menu.

The Side Panel

The side panel provides information about the status of the PMBus™ CI and the device connected to the PMBus™ CI.

The Main Window

The main window of the Pink Power Designer™ has a number of tabs allowing configuration and monitoring for the ZSPM1035A. The following tabs are implemented in the Pink Power Designer™ tool:

- “Power Stage” tab: definition of nominal input and output voltage for the Evaluation Kit.
- “Configuration” tab: configuration of parameters for sequencing and startup.
- “Protection” tab: settings for protection warning and fault levels.
- “Control & Program” tab: calibration procedures and options for downloading of the configuration into the non-volatile memory (NVM).
- “Status & Monitor” tab: status and monitoring functions.

5 Evaluation Kit Setup for a 1.2V Output Voltage

This section covers the steps for powering up the ZSPM8035 Evaluation Kit for the first time.



Important Safety Warning: The following procedures can result in high currents, which can cause severe injury or death. Only trained professional staff should connect external equipment. Do not enable the power supply connected to the input terminals until indicated in the following steps.

Follow this step-by-step instruction to power up the ZSPM8035 Evaluation Board:

Step 1: Make sure no jumpers are connected on headers J107 and J106. This selects the low output voltage range up to 1.2V and the minimum output capacitor range for the Murata OKLP-X/35-W12-C Power Block.

Step 2: Connect the power supply to the connectors labeled CON1 (VINP in Figure 2.1) and CON2 (PGND). Connect the load to the CON3 (VOUT) and CON4 (PGND) connectors. The load can be either a resistor or an electronic load. Connect the PMBus™ CI to connector J103 (see Figure 5.1) and to a USB port on the user's PC.

Step 3: Start the Pink Power Designer™ and follow these steps to load a configuration file using the Murata Power Block Wizard.

- Click the “Murata Power Block Wizard” button as shown in Figure 5.2.
- Select the Murata OKLP-X/35-W12-C Power Block by clicking on it and click “Next” to proceed (see Figure 5.3).
- Select “Range 1: 0.35V to 1.20V (without voltage divider)” by clicking on it, and click “Next” to proceed (see Figure 5.4).

- Select “Range 1: Ceramic Capacitors 200μF to 400μF” and click “Finish” to open the main window of the Pink Power Designer™ GUI (see Figure 5.5).

Figure 5.1 ZSPM8035-KIT PMBus™ CI Connection (Top Side of PCB)

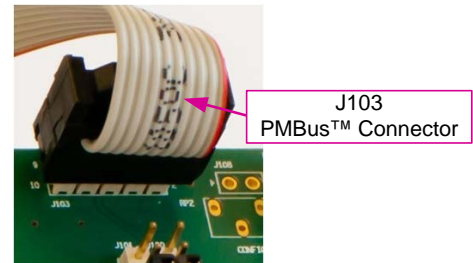

Figure 5.2 Pink Power Designer™ Murata Power Block Wizard Button



Figure 5.3 Pink Power Designer™ Wizard – Power Block Selection

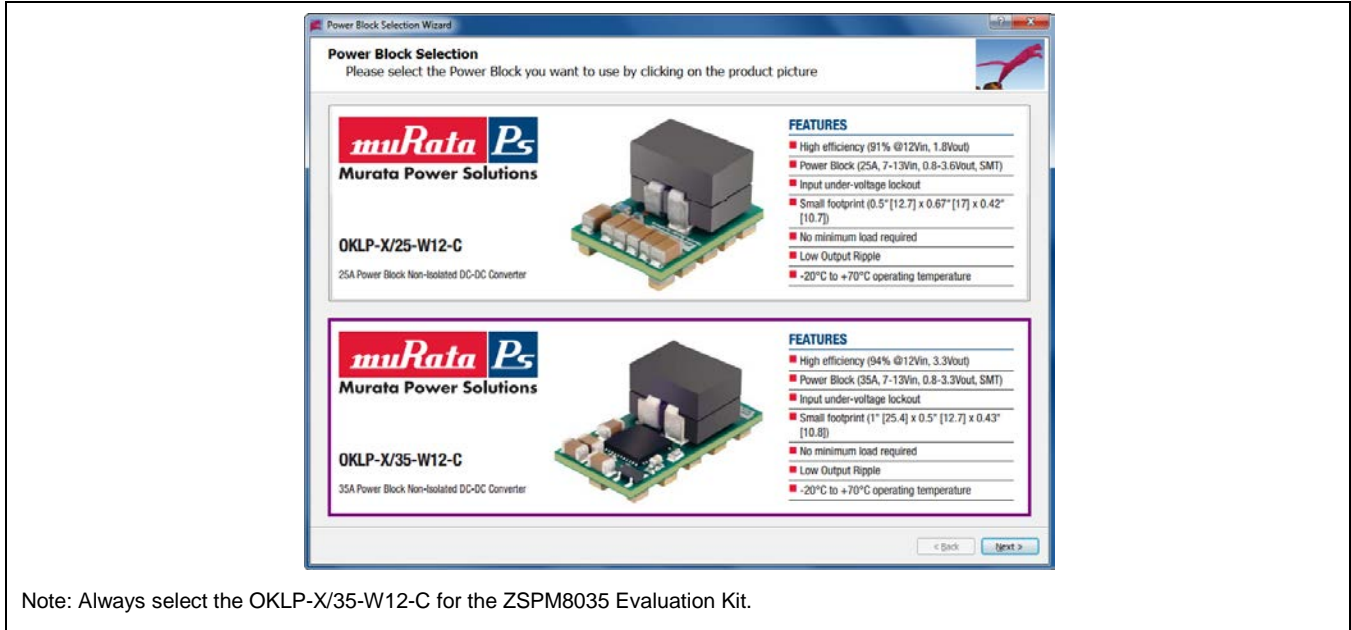

Figure 5.4 Pink Power Designer™ Wizard – Output Voltage Range Selection

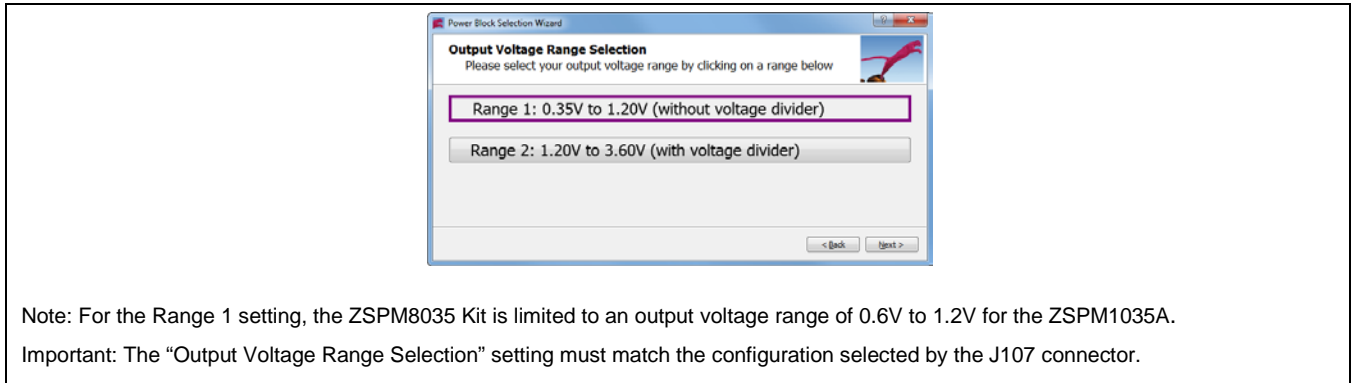
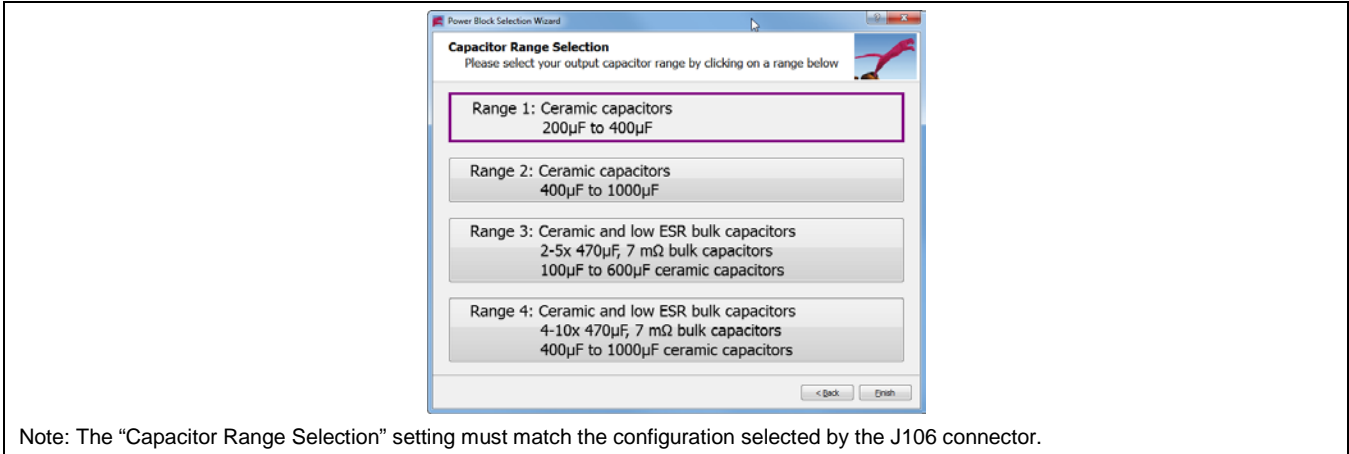

Figure 5.5 Pink Power Designer™ Wizard – Output Capacitor Range Selection



Note: The “Capacitor Range Selection” setting must match the configuration selected by the J106 connector.

Step 4: Set the power supply voltage to 12V and enable the output of the power supply. If the power supply has no enable button, ensure that the output voltage is set to 12V before connecting it to the ZSPM8035 Evaluation Board. The Pink Power Designer™ GUI will now recognize the ZSPM1035A and show the device in the status panel on the left side of the screen (see Figure 5.6).

Note: Because the ZSPM1035A has not yet been configured by the GUI, there should be no voltage present on the output connectors of the ZSPM8035 Evaluation Board at this time.

Step 5: Click on the “Write to Chip” button (see Figure 5.6) in the side panel to program the configuration data into the volatile memory of the ZSPM1035A. It might be necessary to confirm the “Write to Chip” command depending on the state of the ZSPM1035A.

Step 6: Click on the “Status & Monitor” tab and ensure that monitoring is active for the input voltage, output voltage, output current, and the readings of internal and external temperature. The virtual LED next to the “Monitor” button will be green when monitoring is enabled (see Figure 5.7). Click on the “Monitor” button to enable monitoring if the virtual LED is not green.

Step 7: Click on the “Operation CMD” button located in the “Startup” subsection (see Figure 5.7) to enable the output of the ZSPM8035 Evaluation Board. The power-good (PG) LED on the board should be on now (see Figure 2.1) and a voltage of 1.2V should be present on the output terminals. Clicking the “Operation CMD” button again will toggle the output voltage off.

Figure 5.6 “Write to Chip” Button

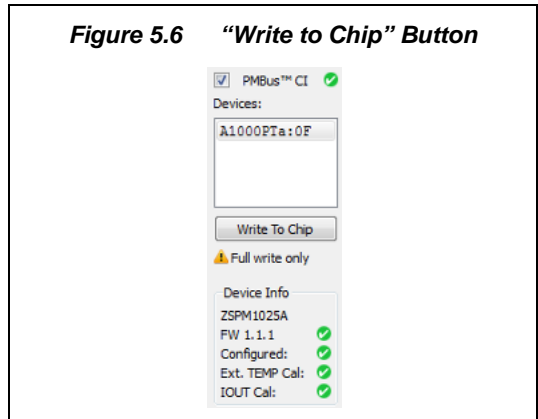

Figure 5.7 “Operation CMD” Button



6 Evaluation Board Hardware and Software Setup

6.1. Introduction

The ZSPM1035A is a configurable controller that must be configured in the Pink Power Designer™ GUI. The GUI is also needed to test the features of the ZSPM8035 Evaluation Board. Eight configuration files for the ZSPM1035A are part of the GUI download package. The GUI wizard will help the user load a configuration file based on a simple selection process. The wizard can be opened within the GUI by selecting “File” -> “New” in the menu, or it can be selected when the Pink Power Designer™ GUI is started on the user’s PC.

The output voltage is set as part of the configuration data in the GUI. For output voltages up to 1.2V, the controller is configured to operate without a feedback divider. For output voltages above 1.2V the controller is configured to operate with a feedback divider in the feedback path. The feedback divider can be enabled by placing a jumper on header J107. Refer to section 6.2 for more information on the output voltage selection on the ZSPM8035 Evaluation Board. The *ZSPM1035A Data Sheet* provides detailed information about the output voltage feedback divider for the ZSPM1035A.

The ZSPM1035A has four pre-configured compensators that can be selected with the GUI or by using the configuration files provided by IDT. The four compensators have been designed to work for specific ranges of output capacitors. Section 6.3 describes how the Evaluation Board can be configured for any of the four capacitor ranges, thereby enabling simple comparisons of the dynamic performance of the complete solution. The output capacitor range can be selected on header J106 (see section 6.3). The *ZSPM1035A Data Sheet* provides further information about the compensation loop configuration of the ZSPM1035A controller and typical performance measurements.

6.2. Setting the Output Voltage

The nominal output voltage can be set in the Pink Power Designer™ GUI. The output voltage range must be selected on jumper J107 before powering up the ZSPM8035 Evaluation Board and loading configuration data into the ZSPM1035A.

Important: Do not combine the higher voltage range of 1.2V to 3.6V (selected by installing the jumper on J107) with the lowest load resistance setting (selected by installing jumpers across pins 2 and 3 on both J101 and J100; see section 6.4).

Figure 6.1 J107 – Output Voltage Range Hardware Selection

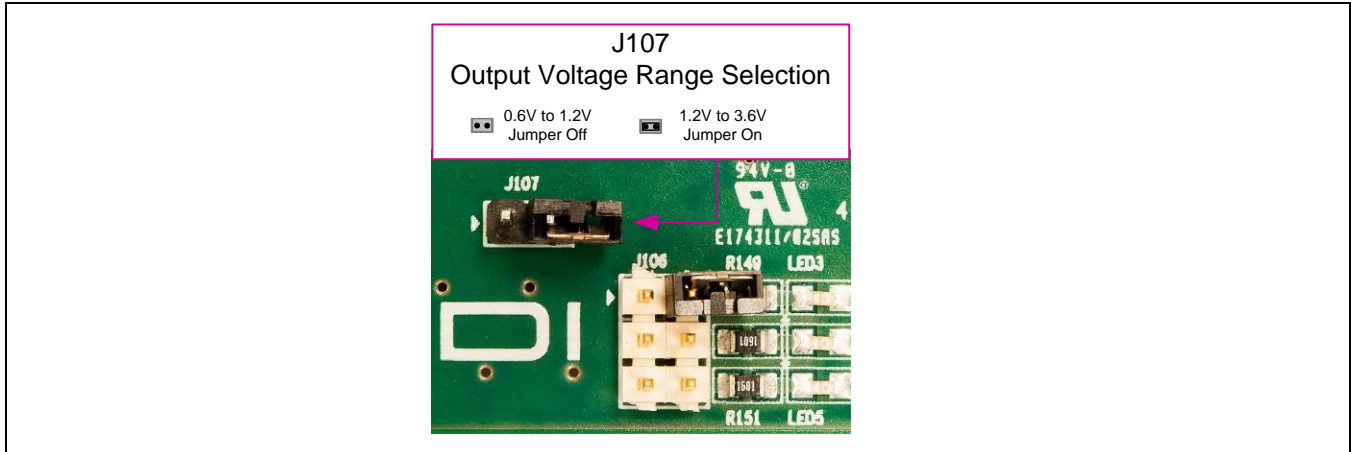

Follow these steps to change the output voltage:

1. **Important:** Ensure that the input voltage from the power supply for the ZSPM8035 Evaluation Board is OFF.
2. Select the ZSPM1035A output voltage range with jumper J107 (see Figure 6.1).
3. Apply the input voltage to the ZSPM8035 Evaluation Board.
4. Use the Pink Power Designer™ Power Block Selection wizard to load the correct configuration file for the selected output voltage range and output capacitor range. Refer to the *Pink Power Designer™ Graphic User Interface (GUI) for the ZSPM1035A*, which is included in the software and can also be downloaded from the ZSPM1035A product page on IDT's web site (<http://www.idt.com/ZSPM1035A>) for full instructions for the software.
5. Enter the nominal output voltage in the "Power Stage" tab of the Pink Power Designer™ GUI.
6. Click "Write to Chip" in the side panel of the Pink Power Designer™ GUI to write the configuration data to the volatile memory of the ZSPM1035A.
7. Enable the output voltage by clicking the "Operation CMD" button in the "Status & Monitor" tab of the Pink Power Designer™ GUI.

6.3. Output Capacitor Range Selection

The ZSPM1035A controller can be configured with four sets of compensation loop parameters. Each set of compensation parameters has been designed to match a range of output capacitors (see the *ZSPM1035A Data Sheet* for more information on the output capacitor ranges). The ZSPM8035 Evaluation Board allows the user to test the performance of the controller for each of the four output capacitor ranges.

A minimum number of ceramic capacitors are always connected to the output of the Murata OKLP-X/35-W12-C Power Block (capacitor range #1, no jumper on J106) and further capacitor banks can be selected with a jumper on header J106 (see Table 6.1). On the Evaluation Board, one of the three LEDs adjacent to J106 will turn green to indicate if capacitor range #2, #3, or #4 has been selected (see Figure 2.1). If none of the LEDs are on, it means that capacitor range #1 has been selected.

Note: It is important that the output capacitor range selected on J106 matches the compensator settings loaded in the Pink Power Designer™ GUI.

Figure 6.2 J106 - Output Capacitor Range Hardware Selection



Table 6.1 ZSPM8035 Evaluation Board – Output Capacitors

Capacitor Range	Ceramic Capacitor	Bulk Electrolytic Capacitors	Header J106
#1	3 x 100µF 6.3V X5R 2 x 47µF 10V X7R	None	
#2	7 x 100µF 6.3V X5R 4 x 47µF 10V X7R	None	
#3	3 x 100µF 6.3V X5R 2 x 47µF 10V X7R	3 x 470µF, 7mΩ ESR	
#4	7 x 100µF 6.3V X5R 4 x 47µF 10V X7R	8 x 470µF, 7mΩ ESR	

Note: Pin 1 on J106 is indicated by ►.

6.3.1. Output Capacitor Range Test Procedure

To test the performance of the four selectable compensators, follow these simple steps:

1. Make sure that the input voltage from the power supply for the ZSPM8035 Evaluation Board is OFF.
2. Select the ZSPM1035A output capacitor range via header J106.

3. Use the “Project selection” dialog box of the Pink Power Designer™ GUI to load a project file for a configuration matching the output capacitor range selected on J106. Select “New” in the “File” menu to open the “Project selection” dialog box. Then click the “Project File” button (see Figure 5.2) to access the list of project files or click “Murata Power Block Wizard” to use the wizard to select a set of configuration parameters for the ZSPM1035A. (For more details on project files, refer to the *Pink Power Designer™ Graphic User Interface (GUI) Guide for the ZSPM1035A*.)
4. Select the output voltage range on jumper J107 (see section 6.2) and enter the nominal output voltage in the “Power Stage” tab of the Pink Power Designer™ GUI.
5. Apply the input voltage to the ZSPM8035 Evaluation Board.
6. Click the “Write to Chip” button in the Pink Power Designer™ GUI to write the configuration data from the project file into the non-volatile memory of the ZSPM1035A.
7. Enable the output voltage by clicking the “Operation CMD” button in the “Status & Monitor” tab of the Pink Power Designer GUI™.
8. Measure the dynamic performance with an oscilloscope using either the on-board transient loads (see section 6.4) or an external electronic load.

6.4. On Board Transient Loads

The ZSPM8035 Evaluation Board has on-board transient loads that can be used to test the dynamic performance of the ZSPM1035A controller. The transient loads consist of a simple timer circuit driving a power MOSFET. The power MOSFET is connected in series with resistors connected across the output of the Murata OKLP-X/35-W12-C Power Block. A schematic of the transient load circuitry is provided in Appendix B.

There are two transient loads that can be enabled via headers J100 and J101 respectively (see Figure 6.3). The two loads can be enabled simultaneously to achieve a larger current step only if the output voltage range has been set to 0.6V to 1.2V (see important warnings below). The timing signal for the transient loads has an ON time of approximately 1 millisecond with a time period of approximately 80 milliseconds (see Figure 6.4).

Important: The load current is a function of the nominal output voltage set in the “Power Stage” tab and the resistance of the transient load. Be sure to calculate the expected load current before enabling the transient loads.

Important: Do not place jumpers on both J100 and J101 with the output voltage range setting for 1.2V to 3.6V (jumper on J107). Enabling both loads simultaneously creates a load resistance of 0.072Ω, which results in an output current that will exceed the current limits of the 35A Murata Power Block if the output voltage is set higher than 2.4V.

Figure 6.3 J100 and J101 – Transient Load Selection



Figure 6.4 Timing for the On-Board Transient Loads

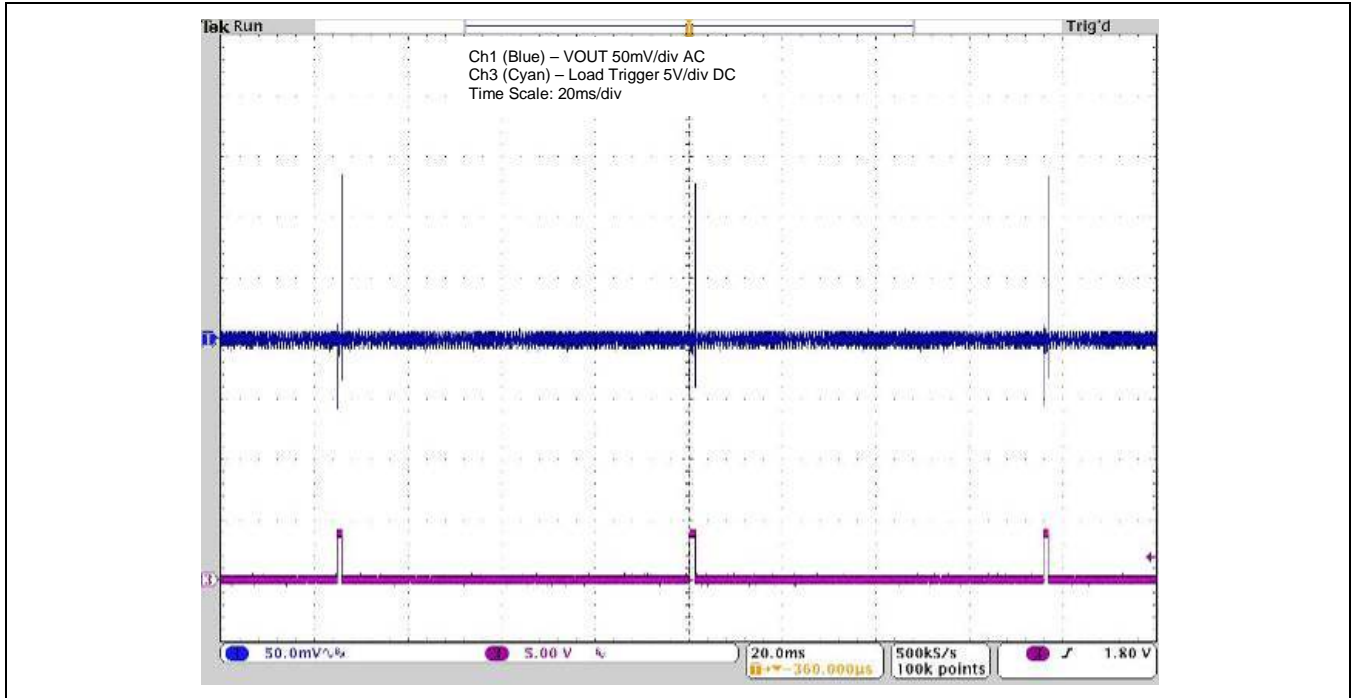

7 Support

IDT provides additional support tools for the ZSPM8035-KIT and the IDT Pink Power Designer™ on the ZSPM1035A web page www.IDT.com/ZSPM1035A. If further support is needed, contact IDT at www.IDT.com/go/support.

8 Related Documents

Document
<i>ZSPM1035A Data Sheet</i>
<i>Pink Power Designer™ Graphic User Interface (GUI) Guide for the ZSPM1035A</i>
<i>ZSPM1025A/ZSPM1035A Application Note – Programming and Calibration</i>

Visit the ZSPM1035A product page (www.IDT.com/ZSPM1035A) or contact your nearest sales office for the latest version of these documents.

9 Definitions of Acronyms

Term	Description
PWM	Pulse Width Modulation
SMB	Sub-miniature Version B

10 Document Revision History

Revision	Date	Description
1.00	January 24, 2014	First release.
1.01	June 13, 2014	Updated cover imagery and contact information. Updated images of software.
	April 11, 2016	Changed to IDT branding.

Appendix A: ZSPM8035 Evaluation Board

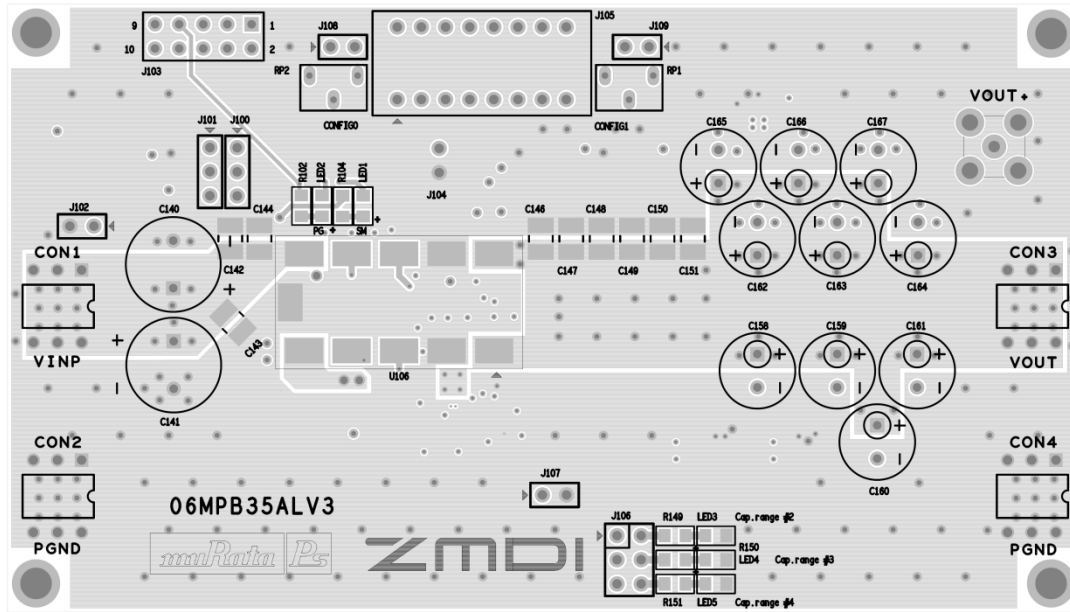

Top Side

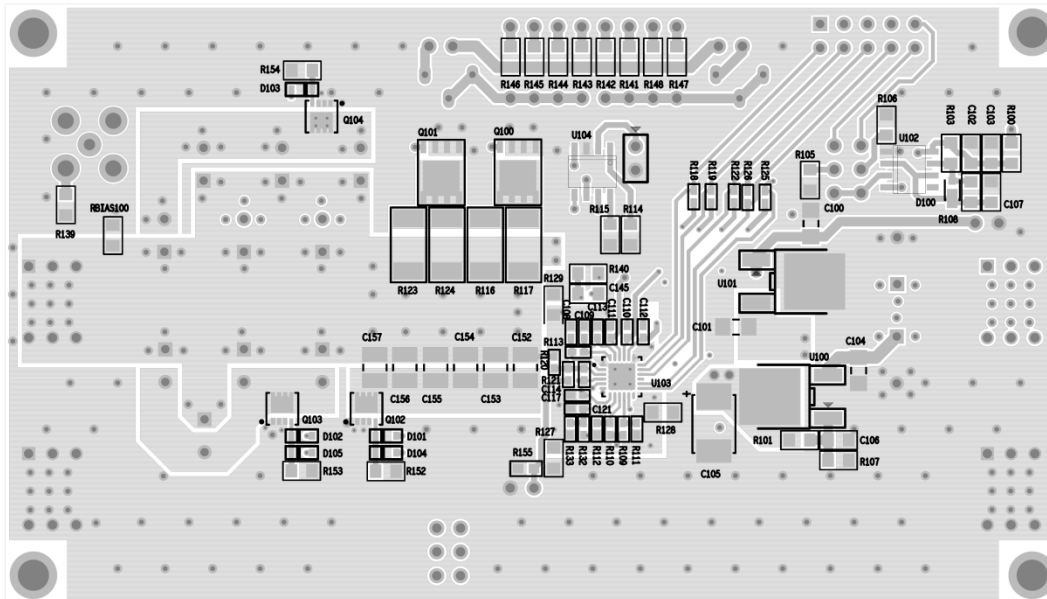

Bottom Side

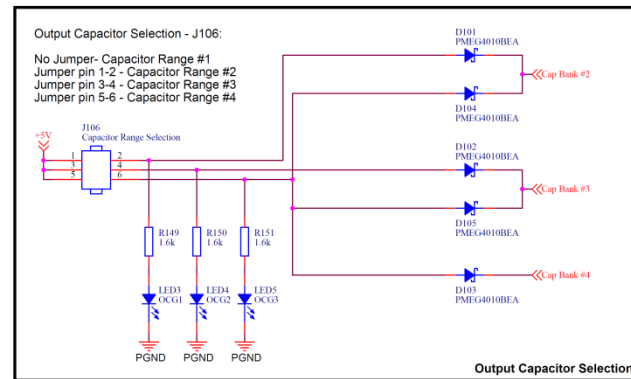
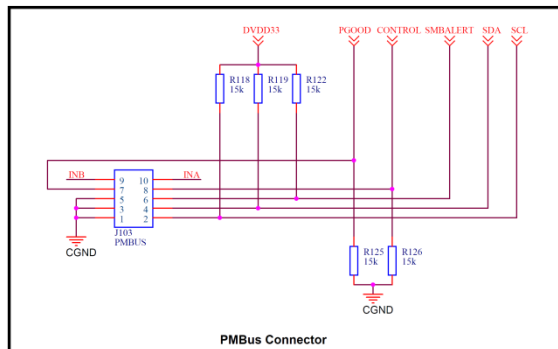
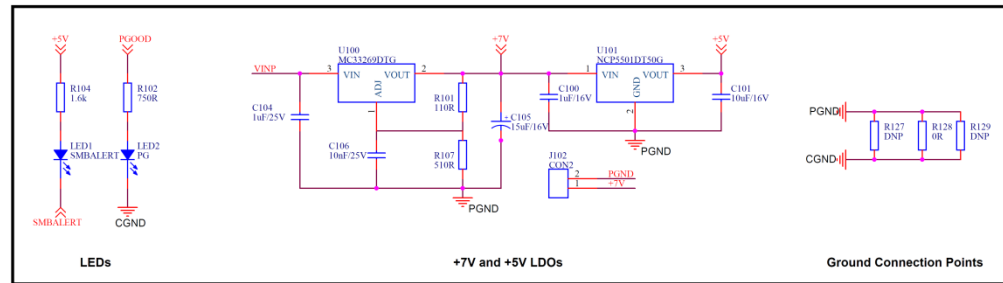
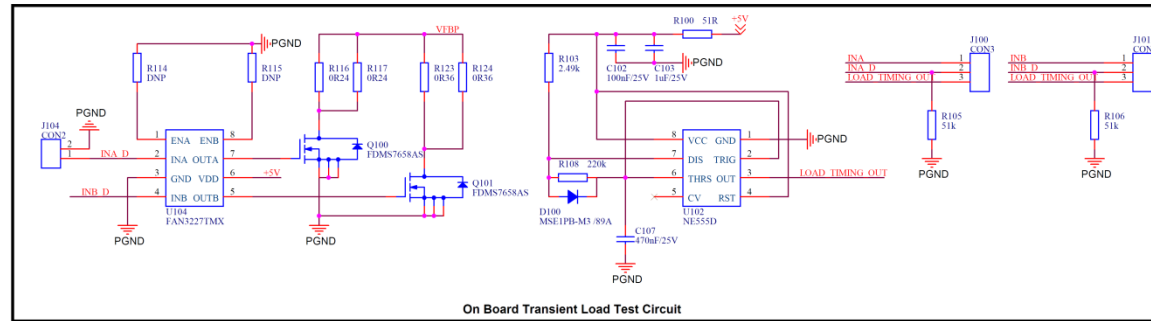
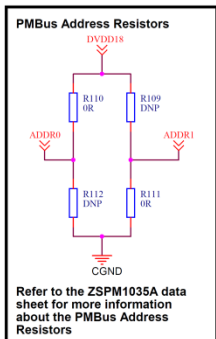
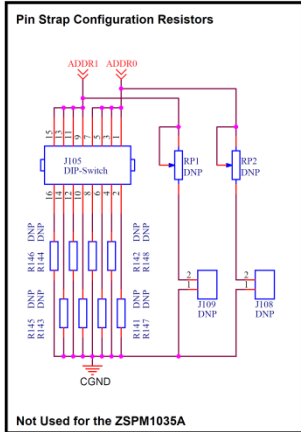

IMPORTANT NOTICE AND DISCLAIMER

RENESAS ELECTRONICS CORPORATION AND ITS SUBSIDIARIES (“RENESAS”) PROVIDES TECHNICAL SPECIFICATIONS AND RELIABILITY DATA (INCLUDING DATASHEETS), DESIGN RESOURCES (INCLUDING REFERENCE DESIGNS), APPLICATION OR OTHER DESIGN ADVICE, WEB TOOLS, SAFETY INFORMATION, AND OTHER RESOURCES “AS IS” AND WITH ALL FAULTS, AND DISCLAIMS ALL WARRANTIES, EXPRESS OR IMPLIED, INCLUDING, WITHOUT LIMITATION, ANY IMPLIED WARRANTIES OF MERCHANTABILITY, FITNESS FOR A PARTICULAR PURPOSE, OR NON-INFRINGEMENT OF THIRD-PARTY INTELLECTUAL PROPERTY RIGHTS.

These resources are intended for developers who are designing with Renesas products. You are solely responsible for (1) selecting the appropriate products for your application, (2) designing, validating, and testing your application, and (3) ensuring your application meets applicable standards, and any other safety, security, or other requirements. These resources are subject to change without notice. Renesas grants you permission to use these resources only to develop an application that uses Renesas products. Other reproduction or use of these resources is strictly prohibited. No license is granted to any other Renesas intellectual property or to any third-party intellectual property. Renesas disclaims responsibility for, and you will fully indemnify Renesas and its representatives against, any claims, damages, costs, losses, or liabilities arising from your use of these resources. Renesas' products are provided only subject to Renesas' Terms and Conditions of Sale or other applicable terms agreed to in writing. No use of any Renesas resources expands or otherwise alters any applicable warranties or warranty disclaimers for these products.

(Disclaimer Rev.1.01 Jan 2024)

Corporate Headquarters

TOYOSU FORESIA, 3-2-24 Toyosu,
Koto-ku, Tokyo 135-0061, Japan
www.renesas.com

Trademarks

Renesas and the Renesas logo are trademarks of Renesas Electronics Corporation. All trademarks and registered trademarks are the property of their respective owners.

Contact Information

For further information on a product, technology, the most up-to-date version of a document, or your nearest sales office, please visit www.renesas.com/contact-us/.