

This layout guide provides some important information about the PCB layout of SLG59M1598V applications.

SILEGO TDFN 1 x 1.6 - 8L PKG

Unit: um

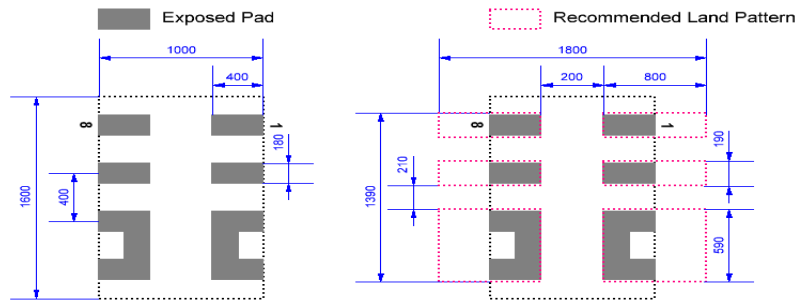

Figure 2. SLG59M1598V Package Dimensions and Recommended Land Pattern

Please solder your SLG59M1598V here

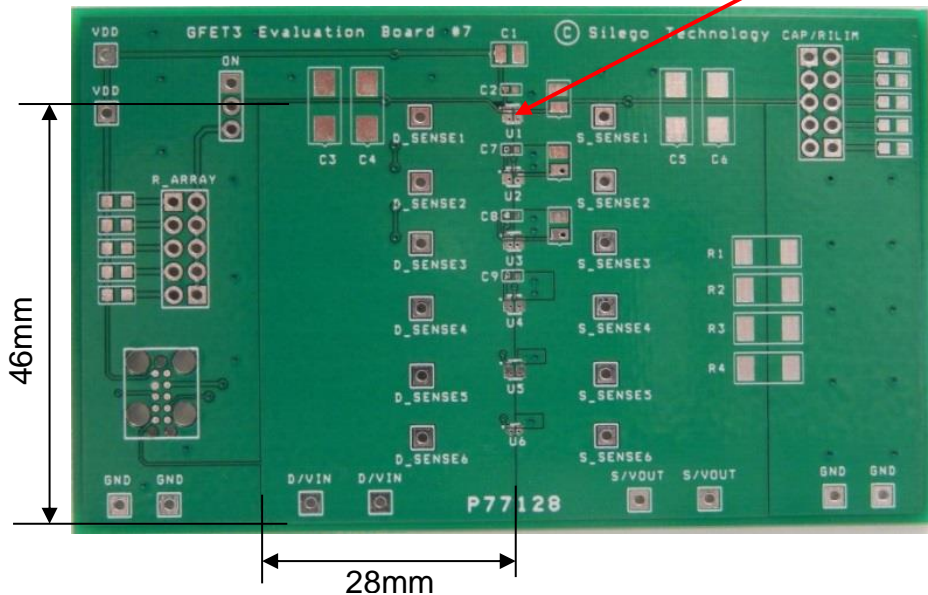

Figure 3. SLG59M1598V Evaluation Test Board

Note: Evaluation board has D_Sense and S_Sense pads. Please use them only for RDS(ON) evaluation.

2. Power and Ground Planes

2.1. The VDD pin needs 0.1uF external capacitor to smooth pulses from the power supply. Locate these capacitor close to PIN1.

2.2. The trace length from the control IC to the ON pin should be as short as possible and must avoid crossing this trace with power rails.

2.3. The D/VIN and S/VOUT pins carry significant current. Please note how the D/VIN and S/VOUT pads are placed directly on the power planes in Figure 3, which minimizes the RDS(ON) associated with long, narrow traces. The D/VIN and S/VOUT pins dissipate most of the heat generated during high-load current condition. The layout shown in Figure 3 is illustrating a proper solution for heat to transfer as efficiently as possible out of the device.

2.4. Place the power rail ramp capacitor as close as possible to the CAP pin (PIN7) to avoid/reduce the effect of parasitic mount capacitance.

2.5. The GND pin (PIN8) should be connected to GND.

2.6. 2 oz. copper is recommended for higher currents.