

General Description

The HXR8204 Transimpedance Limiting Amplifier array is a member of IDT’s family of Optical Receiver Transmitter Array (ORTA) products targeted at the parallel optical links market. Together with a PIN detector array or discrete detectors, high-capacity, high-availability optical links can be designed for telecom and datacom applications.

The 3.3V SiGe device integrates the transimpedance pre-amplifier, the limiting post-amplifier, and a versatile CML output stage for four optical channels.

Features

- 60 μ App receiver sensitivity for 10^{-12} BER at 28Gbps
- Better than 2.4 mA_{pp} overload
- 126 mW per channel power consumption
- Adjustable output swing size and pre-emphasis in limiting mode and signal detect threshold
- Independent, per channel RSSI
- Optimized for isolated and common cathode photo-detector arrays from multiple vendors
- Control lines accessible on both sides of chip
- QSFP MSA compliance

Applications

- 100G Ethernet SR4 modules
- 100G Ethernet AOC
- InfiniBand EDR 100G transceivers
- InfiniBand EDR 100G active cables
- Proprietary multi-channel optical modules

Ordering Information

Part	Temp Range	Pin-Package
HXR8204-DNT	0°C to +85°C	Bare Die* 1.975mm x 1.6mm
HXR8204-EVB	Room temp	Evaluation Board

* Die Design Size; Actual die size may be slightly larger

For price, delivery schedules, and to place orders, please contact IDT: www.IDT.com/go/sales

Device Diagram

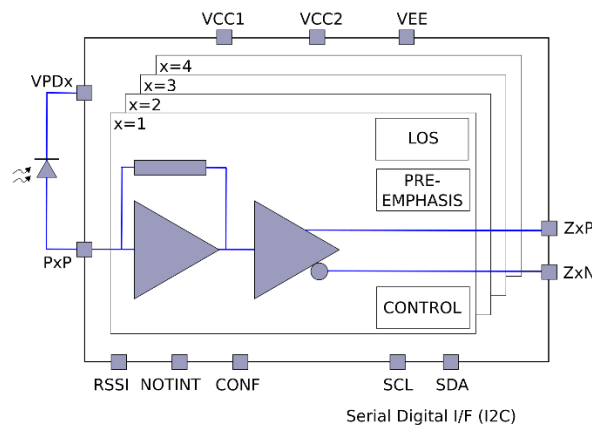

Figure 1: Device diagram

**Corporate Headquarters**

6024 Silver Creek Valley Road
San Jose, CA 95138

www.IDT.com

Sales

1-800-345-7015 or 408-284-8200
Fax: 408-284-2775

www.IDT.com/go/sales

Tech Support

www.IDT.com/go/support

DISCLAIMER Integrated Device Technology, Inc. (IDT) and its affiliated companies (herein referred to as "IDT") reserve the right to modify the products and/or specifications described herein at any time, without notice, at IDT's sole discretion. Performance specifications and operating parameters of the described products are determined in an independent state and are not guaranteed to perform the same way when installed in customer products. The information contained herein is provided without representation or warranty of any kind, whether express or implied, including, but not limited to, the suitability of IDT's products for any particular purpose, an implied warranty of merchantability, or non-infringement of the intellectual property rights of others. This document is presented only as a guide and does not convey any license under intellectual property rights of IDT or any third parties.

IDT's products are not intended for use in applications involving extreme environmental conditions or in life support systems or similar devices where the failure or malfunction of an IDT product can be reasonably expected to significantly affect the health or safety of users. Anyone using an IDT product in such a manner does so at their own risk, absent an express, written agreement by IDT.

Integrated Device Technology, IDT and the IDT logo are trademarks or registered trademarks of IDT and its subsidiaries in the United States and other countries. Other trademarks used herein are the property of IDT or their respective third party owners. For datasheet type definitions and a glossary of common terms, visit www.idt.com/go/glossary. All contents of this document are copyright of Integrated Device Technology, Inc. All rights reserved.