

General Description

The HXT42400 is a quad channel, low power, Direct Modulated Laser (DML) driver array for LR4 optical applications that supports data rates up to 28Gbps and optical reach up to 10km. In conjunction with a DFB laser diode array or individual DFB laser diodes, the device handles the complete digital-to-optical conversion, including CML input with equalization, laser driver, drive control, and supervision.

Designed for direct DC-coupled die in TOSA applications with a small number of additional components for cost-effective and compact assemblies. Available in die form.

Applications

- Up to 10km LR4 100G-BASE Ethernet modules for datacenters
- Up to 2km CLR4 100G-BASE Ethernet modules for datacenters
- 128G Fiber Channel modules to 10km
- 32G Fiber Channel modules to 10km
- InfiniBand EDR optical modules
- Proprietary multi-channel optical modules

Ordering Information

Part	Temp Range	Pin-Package
HXT42400-DNU ¹ HXT42400-TNU ²	-5°C to +95°C	Bare Die Design Size: 1300µm x 3320µm Nominal Die Cut Size: 1350 µm x 3370 µm
HXT42400EVB	Room Temp	Evaluation Board

Notes:

¹ – Waffle Pack

² – Blue Tape

Features

- 200mW device power dissipation when configured for:
 - $I_{MOD} = 50mA_{PP}$
 - $I_{BIAS} = 50mA$
- Supports up to: $I_{MOD} = 50mA_{PP}$ & $I_{BIAS} = 50mA$ with $V_{CC} = 2.5V$
- Programmable Input Equalization
- Programmable Input Signal Detect (SD) with Squelch
- Programmable Input Polarity Inversion
- Programmable Pulse Width Adjustment
- Programmable Laser Modulation Current Amplitude, Peaking, and Peaking Duration
- Integrated Temperature Sensor
- Interrupts with user selectable mask control
- Laser Disable for I_{MOD} and I_{BIAS}
- 2-wire interface control and symmetric pad design maximize module design flexibility
- QSFP MSA compliant

For price, delivery schedules, and to place orders, please contact IDT: www.IDT.com/go/sales

Device Diagram

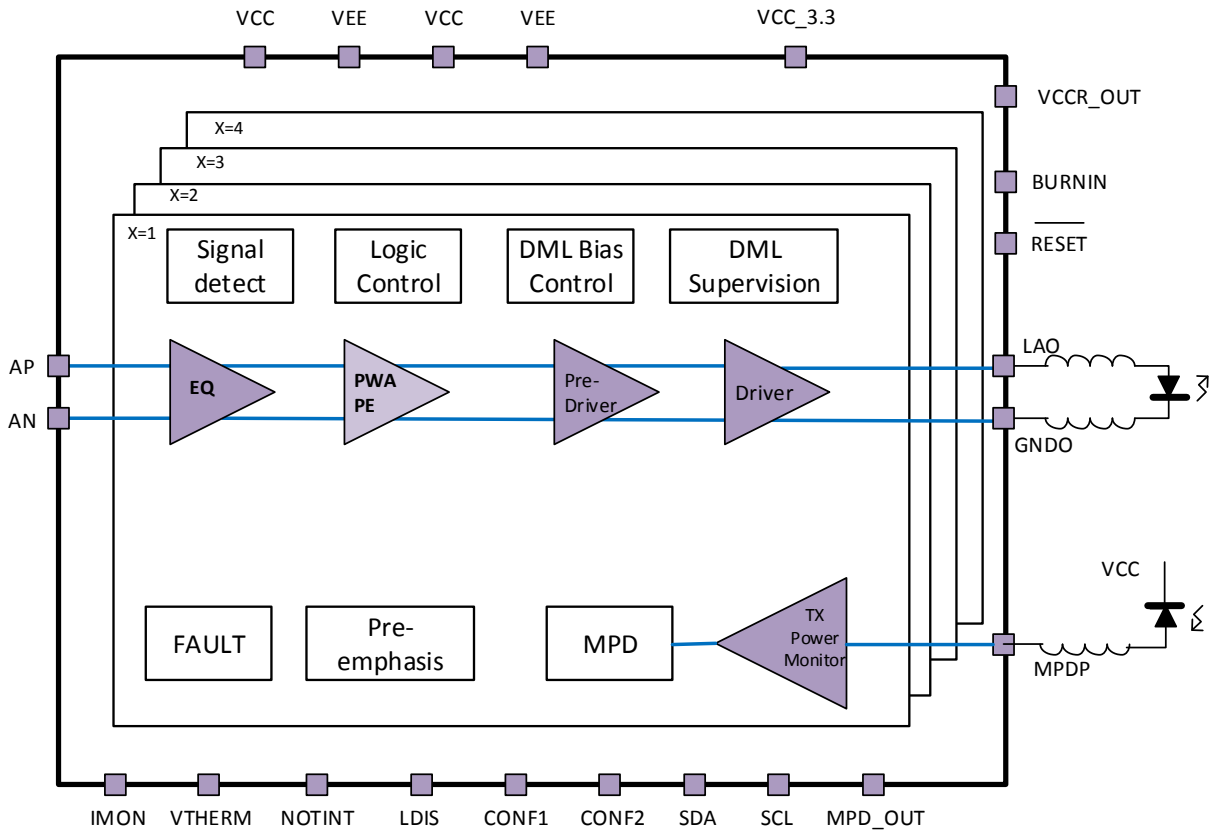

Figure 1: Functional block diagram

**Corporate Headquarters**

6024 Silver Creek Valley Road
San Jose, CA 95138
www.IDT.com

Sales

1-800-345-7015 or 408-284-8200
Fax: 408-284-2775
www.IDT.com/go/sales

Tech Support

www.IDT.com/go/support

DISCLAIMER Integrated Device Technology, Inc. (IDT) and its affiliated companies (herein referred to as "IDT") reserve the right to modify the products and/or specifications described herein at any time, without notice, at IDT's sole discretion. Performance specifications and operating parameters of the described products are determined in an independent state and are not guaranteed to perform the same way when installed in customer products. The information contained herein is provided without representation or warranty of any kind, whether express or implied, including, but not limited to, the suitability of IDT's products for any particular purpose, an implied warranty of merchantability, or non-infringement of the intellectual property rights of others. This document is presented only as a guide and does not convey any license under intellectual property rights of IDT or any third parties.

IDT's products are not intended for use in applications involving extreme environmental conditions or in life support systems or similar devices where the failure or malfunction of an IDT product can be reasonably expected to significantly affect the health or safety of users. Anyone using an IDT product in such a manner does so at their own risk, absent an express, written agreement by IDT.

Integrated Device Technology, IDT and the IDT logo are trademarks or registered trademarks of IDT and its subsidiaries in the United States and other countries. Other trademarks used herein are the property of IDT or their respective third party owners. For datasheet type definitions and a glossary of common terms, visit www.idt.com/go/glossary. All contents of this document are copyright of Integrated Device Technology, Inc. All rights reserved.